

**ZGB036, 048, 060, 074**

The ZGB packaged gas units are available in standard cooling efficiency (036S, 048S, 060S, 074S). Cooling capacities are 3, 4, 5 and 6 tons (10.6 to 20.3kW).

All units are available in single-stage 65,000 BTUH (19 kW), single-stage 108,000 BTUH (32 kW) and two-stage 81/108,000 BTUH (24/32 kW) heat capacities. ZGB048, 060 and 074 units are available in single-stage 150,000 BTUH (44 kW) and two-stage 113/150,000 BTUH (33/44 kW) heat capacities. Gas heat sections are designed with aluminized steel tube heat exchangers.

Information contained in this manual is intended for use by qualified service technicians only. All specifications are subject to change. Procedures outlined in this manual are presented as a recommendation only and do not supersede or replace local or state codes.

If the unit must be lifted for service, rig unit by attaching four cables to the holes located in the unit base rail (two holes at each corner). Refer to the installation instructions for the proper rigging technique. Stacking brackets can be removed or left on the unit permanently. If brackets are removed, any screws removed during installation must be replaced.

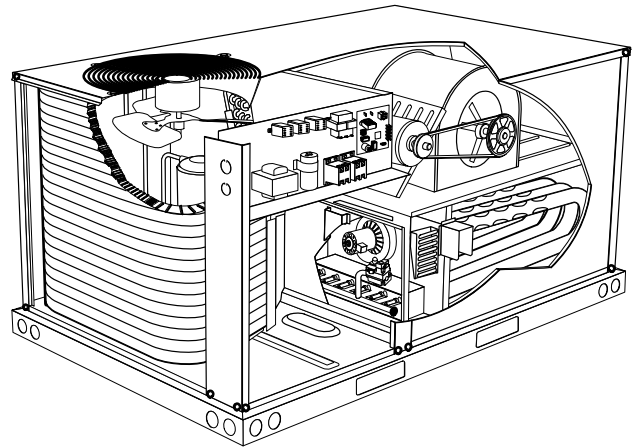

**ELECTROSTATIC DISCHARGE (ESD)**

**Precautions and Procedures**

**⚠ CAUTION**



Electrostatic discharge can affect electronic components. Take precautions to neutralize electrostatic charge by touching your hand and tools to metal prior to handling the control.

**⚠ WARNING**

Improper installation, adjustment, alteration, service or maintenance can cause property damage, personal injury or loss of life. Installation and service must be performed by a licensed professional installer (or equivalent), service agency or the gas supplier.

**⚠ WARNING**



Electric shock hazard. Can cause injury or death. Before attempting to perform any service or maintenance, turn the electrical power to unit OFF at disconnect switch(es). Unit may have multiple power supplies.

**⚠ CAUTION**

Danger of sharp metallic edges. Can cause injury. Take care and wear protective clothing when servicing unit to avoid accidental contact with sharp edges.

**Table of Contents**

Options .....	Page 2
Specifications .....	Page 4
Spec. Gas Heat / High Altitude ...	Page 6
Blower Data .....	Page 7
Electrical Data .....	Page 14
I Unit Components .....	Page 17
II Placement and Installation .....	Page 27
III Start Up Operation .....	Page 27
IV Charging .....	Page 29
V System Service Checks .....	Page 33
VI Maintenance .....	Page 35
VII Accessories .....	Page 37
VIII Diagrams .....	Page 43

OPTIONS / ACCESSORIES						
Item	Catalog No.	Unit Model No.				
		ZGB 036	ZGB 048	ZGB 060	ZGB 074	
COOLING SYSTEM						
Condensate Drain Trap	PVC - C1TRAP20AD2	<b>76W26</b>	X	X	X	X
	Copper - C1TRAP10AD2	<b>76W27</b>	X	X	X	X
Drain Pan Overflow Switch	Z1SNSR90A1	<b>99W59</b>	X	X	X	X
Low Ambient Kit	Z1SNSR33A-1	<b>99W67</b>	X	X	X	X
HEATING SYSTEM						
Gas Heat Input	Standard 1-Stage - 65 kBtuh input	Factory	O	O	O	O
	Medium 1-Stage - 108 kBtuh input	Factory	O	O	O	O
	Medium 2-Stage - 65/108 kBtuh input	Factory	O	O	O	O
	High 1-Stage - 150 kBtuh input	Factory		O	O	O
	High 2-Stage - 113/150 kBtuh input	Factory		O	O	O
LPG/Propane Conversion Kits	For 1-Stage models - C1PROP10AP3	<b>14N20</b>	X	X	X	X
	For 2-Stage models - C1PROP20AP3	<b>14N21</b>	X	X	X	X
Vertical Vent Extension Kit	C1EXTN20FF1	<b>31W62</b>	X	X	X	X
Blower - SUPPLY AIR						
Motors	Belt Drive - 0.75 hp (208/230V-1ph) Standard Efficiency	Factory	O	O	O	
	Belt Drive - 1 hp (208/230V, 460V, 575V-3ph) Standard Efficiency	Factory	O	O	O	
	Belt Drive - 1.5 hp (208/230V-1ph or 3 ph, 460V, 575V-3ph) Standard Efficiency	Factory	O	O	O	<sup>3</sup> O
	Belt Drive - 2 hp (208/230V, 460V, 575V-3ph) Standard Efficiency	Factory				<sup>3</sup> O
	Belt Drive - 2 hp (208/230V, 460V, 575V-3ph) (2 Speed)	Factory				<sup>4</sup> O
Drive Kits See Blower Data Tables for selection	Kit #Z01 - 678-1035 rpm	Factory	O			
	Kit #Z02 - 803-1226 rpm	Factory		O		
	Kit #Z03 - 906-1383 rpm	Factory			O	
	Kit #Z04 - 964-1471 rpm	Factory	O			
	<sup>1</sup> Kit #Z05 - 1098-1490 rpm	Factory		O		
	<sup>1</sup> Kit #Z06 - 1262-1634 rpm	Factory			O	
	Kit #ZAA02 - 632-875 rpm	Factory				O
	Kit #ZAA03 - 798-1105 rpm	Factory				O
<sup>2</sup> Kit #ZAA04 - 921-1226 rpm	Factory				O	
CABINET						
Coil/Hail Guards	Z1GARD52A-1	<b>12X19</b>	X	X		
	Z1GARD52AT1	<b>12X20</b>			X	X
Corrosion Protection		Factory	O	O	O	O
ELECTRICAL						
Voltage 60 hz	208/230V - 1 phase	Factory	O	O	O	
	208/230V - 3 phase	Factory	O	O	O	O
	460V - 3 phase	Factory	O	O	O	O
	575V - 3 phase	Factory	O	O	O	O
Bottom Power Entry Kit	Z1PEKT01A-1	<b>98W08</b>	X	X	X	X

<sup>1</sup> 1.5 hp blower motor is required with the ZAA05 and ZAA06 drive kits.

<sup>2</sup> 2 hp blower motor is required with the ZAA04 drive kit.

<sup>3</sup> 074S4B models only.

<sup>4</sup> 074S4T models only.

NOTE - The catalog and model numbers that appear here are for ordering field installed accessories only.

OX - Field Installed or Configure to Order (factory installed)

O - Configure to Order (Factory Installed)

X - Field Installed.

**OPTIONS / ACCESSORIES**

Item	Catalog No.	Unit Model No.				
		ZGB 036	ZGB 048	ZGB 060	ZGB 074	
<b>ECONOMIZERS</b>						
<b>Standard Economizer With Outdoor Air Hood (Not for Title 24)</b>						
Standard Economizer (Downflow) Includes Barometric Exhaust Dampers and Exhaust Hood	Z1ECON30A-2	<b>14D94</b>	OX	OX	OX	OX
Standard Economizer (Horizontal) Includes Barometric Exhaust Dampers and Exhaust Hood	Z1ECON16A-2	<b>14D92</b>	X	X	X	X
<b>Standard Economizer Controls (Not for Title 24)</b>						
Single Enthalpy Control	C1SNSR64FF1	<b>53W64</b>	X	X	X	X
<b>High Performance Economizer With Outdoor Air Hood (Approved for California Title 24 Building Standards / AMCA Class 1A Certified)</b>						
High Performance Economizer (Downflow) Includes Barometric Exhaust Dampers and Exhaust Hood	Z1ECON32A-2	<b>14D95</b>	OX	OX	OX	OX
High Performance Economizer (Horizontal) Includes Barometric Exhaust Dampers and Exhaust Hood	Z1ECON33A-2	<b>14D93</b>	X	X	X	X
<b>High Performance Economizer Controls (Not for Title 24)</b>						
Single Enthalpy Control	C1SNSR61FF1	<b>11G21</b>	X	X	X	X
<b>OUTDOOR AIR</b>						
<b>Outdoor Air Dampers With Outdoor Air Hood</b>						
Motorized	Z1DAMP21A-2	<b>15D19</b>	X	X	X	X
Manual	Z1DAMP11A-2	<b>15D20</b>	X	X	X	X
Power EXhaust FAN						
Standard Static (Downflow)	208/230V-1 or 3ph - Z1PWRE10A-1P	<b>21E01</b>	X	X	X	X
	460V-3ph - Z1PWRE10A-1G	<b>23E01</b>	X	X	X	X
Standard Static (Horizontal)	208/230V-1 or 3ph - Z1PWRE15A-1P	<b>24E01</b>	X	X	X	X
	460V-3ph - Z1PWRE15A-1G	<b>28E01</b>	X	X	X	X
575V Transformer Kit	575V-3ph - Z1TRFM20A-1J	<b>59E02</b>	X	X	X	X
NOTE - Order 575V Transformer Kit with 208/230V Power Exhaust Fan for 575V applications.						
<b>Indoor Air Quality</b>						
<b>Indoor Air Quality (CO<sub>2</sub>) Sensors</b>						
Sensor - Wall-mount, off-white plastic cover with LCD display	C0SNSR50AE1L	<b>77N39</b>	X	X	X	X
Sensor - Wall-mount, black plastic case, no display, rated for plenum mounting	C0SNSR53AE1L	<b>87N54</b>	X	X	X	X
CO <sub>2</sub> Sensor Duct Mounting Kit - for downflow applications	C0MISC19AE1	<b>85L43</b>	X	X	X	X
Aspiration Box - for duct mounting non-plenum rated CO <sub>2</sub> sensor ( <b>77N39</b> )	C0MISC16AE1	<b>90N43</b>	X	X	X	X
<b>ROOF CURBS</b>						
<b>Hybrid Roof Curbs, Downflow</b>						
8 in. height	Z1CURB70A-1	<b>11F76</b>	X	X	X	X
14 in. height	Z1CURB71A-1	<b>11F77</b>	X	X	X	X
18 in. height	Z1CURB72A-1	<b>11F78</b>	X	X	X	X
24 in. height	Z1CURB73A-1	<b>11F79</b>	X	X	X	X
<b>CEILING DIFFUSERS</b>						
Step-Down - Order one	RTD9-65S	<b>13K60</b>	X	X	X	
	RTD11-95S	<b>13K61</b>				X
Flush - Order one	FD9-65S	<b>13K55</b>	X	X	X	
	FD11-95S	<b>13K56</b>				X

NOTE - Ceiling Diffuser Transitions are not furnished and must be field fabricated.

NOTE - The catalog and model numbers that appear here are for ordering field installed accessories only.

OX - Field Installed or Configure to Order (factory installed)

O - Configure to Order (Factory Installed)

X - Field Installed.

**SPECIFICATIONS**

<b>General Data</b>		<b>Nominal Tonnage</b>	<b>3 Ton</b>	<b>4 Ton</b>	<b>5 Ton</b>
		<b>Model No.</b>	<b>ZGB036S4B</b>	<b>ZGB048S4B</b>	<b>ZGB060S4B</b>
		<b>Efficiency Type</b>	<b>Standard</b>	<b>Standard</b>	<b>Standard</b>
		<b>Blower Type</b>	Single Speed Belt Drive	Single Speed Belt Drive	Single Speed Belt Drive
<b>Cooling Performance</b>	Gross Cooling Capacity - Btuh		36,200	46,700	58,300
	Net Cooling Capacity - Btuh		<sup>1</sup> 35,000	<sup>1</sup> 45,500	<sup>1</sup> 57,000
	AHRI Rated Air Flow - cfm		1190	1380	1725
	<sup>3</sup> Sound Rating Number (SRN) (dBA)		78	80	78
	Total Unit Power - kW		3.0	4.1	5.1
	SEER (Btuh/Watt)		<sup>1</sup> 14.00	<sup>1</sup> 14.00	<sup>1</sup> 14.00
	IEER (Btuh/Watt)		---	---	---
	EER (Btuh/Watt)		<sup>1</sup> 11.70	<sup>1</sup> 11.20	<sup>1</sup> 11.20
<b>Refrigerant</b>	Type		R-410A	R-410A	R-410A
	Charge Furnished		5 lbs. 2 oz.	5 lbs. 4 oz.	7 lbs. 5 oz.
<b>Gas Heating Options - See page 5</b>			<b>Standard (1 Stage) or Medium (1 or 2 Stage)</b>	<b>Standard (1 Stage), Medium (1 or 2 Stage) or High (1 or 2 Stage)</b>	
<b>Compressor Type (one per unit)</b>			Scroll	Scroll	Scroll
<b>Outdoor Coil</b>	Net face area - sq. ft.		15.2	15.2	19.9
	Number of rows		1	1	1
	Fins / inch		23	23	23
<b>Outdoor Coil Fan</b>	Motor HP		(1) 1/4	(1) 1/4	(1) 1/4
	Motor rpm		825	825	825
	Total motor watts		310	310	310
	Diameter (No.) - in.		(1) 22	(1) 22	(1) 22
	Number of blades		4	4	4
	Total air volume - cfm		3700	3700	3700
<b>Indoor Coil</b>	Net face area - sq. ft.		8.40	8.4	10.8
	Tube diameter - in.		3/8	3/8	3/8
	Number of rows		3	3	3
	Fins per inch		14	14	14
	Drain Connection (no. and size) - in.		(1) 1 NPT	(1) 1 NPT	(1) 1 NPT
	Expansion device type		Fixed Orifice	Fixed Orifice	Fixed Orifice
<sup>4</sup> <b>Indoor Blower &amp; Drive Selection</b>	Nominal Motor HP		<sup>5</sup> 0.75 hp, <sup>6</sup> 1 hp, 1.5 hp	<sup>5</sup> 0.75 hp, <sup>6</sup> 1 hp, 1.5 hp	<sup>5</sup> 0.75 hp, <sup>6</sup> 1 hp, 1.5 hp
	Maximum Usable Motor HP		0.86, 1.15 hp, 1.7 hp	0.86, 1.15 hp, 1.7 hp	0.86, 1.15 hp, 1.7 hp
	Available Drive Kits		Kit #ZA01 678-1035 rpm	Kit #ZA02 803-1226 rpm	Kit #ZA03 906-1383 rpm
			Kit #ZA04 964-1471 rpm	<sup>7</sup> Kit #ZA05 1098-1490 rpm	<sup>7</sup> Kit #ZA06 1262-1634 rpm
<b>Wheel nominal diameter x width - in.</b>			10 x 10	10 x 10	10 x 10
<b>Filters</b>	Type		Disposable		
	Number and size - in.		(4) 14 x 20 x 2		(2) 16 x 20 x 2 (2) 20 x 20 x 2
<b>Electrical Characteristics - 60 Hz</b>			208/230V 1 phase	208/230V, 1 phase	208/230V, 1 phase
			208/230V, 460V & 575V 3 phase	208/230V 460V & 575V 3 phase	208/230V 460V & 575V 3 phase

NOTE - Net capacity includes evaporator blower motor heat deduction. Gross capacity does not include evaporator blower motor heat deduction.

<sup>1, 2</sup> AHRI Certified to AHRI Standard <sup>1</sup> 210/240 or <sup>2</sup> 340/360: 95°F outdoor air temperature and 80°F db/67°F wb entering evaporator air; minimum external duct static pressure.

<sup>3</sup> Sound Rating Number (SRN) rated in accordance with test conditions included in ANSI/AHRI Standard 270-2008.

<sup>4</sup> Using total air volume and system static pressure requirements determine from blower performance tables rpm and motor hp required. Maximum usable hp of motors furnished are shown. In Canada, nominal motor hp is also maximum usable motor hp output. If motors of comparable hp are used, be sure to keep within the service factor limitations outlined on the motor nameplate.

<sup>5</sup> 0.75 hp motor is only available for 208/230V-1ph applications.

<sup>6</sup> 1 hp blower motor is not available for 208/230V-1ph applications.

<sup>7</sup> 1.5 hp motor is required with the ZA05 and ZA06 drive kits.

SPECIFICATIONS

6 TON

General Data		Nominal Tonnage	6 Ton	6 Ton	
		Model No.	ZGB074S4B	ZGB074S4T	
		Efficiency Type	Standard	Standard	
		Blower Type	Single Speed Belt Drive	Two Speed Belt Drive	
<b>Cooling Performance</b>	Gross Cooling Capacity - Btuh		68,500	68,500	
	Net Cooling Capacity - Btuh		67,000	<sup>2</sup> 67,000	
	AHRI Rated Air Flow - cfm		2200	2200	
	<sup>3</sup> Sound Rating Number (SRN) (dBA)		84	84	
	Total Unit Power - kW		6.0	<sup>2</sup> 6.0	
	SEER (Btuh/Watt)		---	---	
	IEER (Btuh/Watt)		12.7	<sup>2</sup> 15.00	
	EER (Btuh/Watt)		11.0	<sup>2</sup> 11.0	
<b>Refrigerant</b>	Type		R-410A	R-410A	
	Charge Furnished		7 lbs. 3 oz.	7 lbs. 3 oz.	
<b>Gas Heating Options - See page 5</b>			<b>Standard (1 stage), Medium (1 or 2 stage) or High (1 or 2 stage)</b>	<b>Standard (1 stage), Medium (1 or 2 stage) or High (1 or 2 stage)</b>	
<b>Compressor Type (one per unit)</b>			Two-Stage Scroll	Two-Stage Scroll	
<b>Outdoor Coil</b>	Net face area - sq. ft.		19.9	19.9	
	Number of rows		1	1	
	Fins / inch		23	23	
<b>Outdoor Coil Fan</b>	Motor HP		(1) 1/3	(1) 1/3	
	Motor rpm		1075	1075	
	Total motor watts		365	365	
	Diameter (No.) - in.		(1) 24	(1) 22	
	Number of blades		3	3	
	Total air volume - cfm		4270	4270	
<b>Indoor Coil</b>	Net face area - sq. ft.		10.8	10.8	
	Tube diameter - in.		3/8	3/8	
	Number of rows		3	3	
	Fins per inch		14	14	
	Drain Connection (no. and size) - in.		(1) 1 NPT	(1) 1 NPT	
	Expansion device type		Balance Port TXV, removable head	Balance Port TXV, removable head	
<b><sup>4</sup> Indoor Blower &amp; Drive Selection</b>	Nominal Motor HP		1.5 hp, 2 hp	2 hp	
	Maximum Usable Motor HP		1.7 hp, 2.3 hp	2.3 hp	
	Available Drive Kits	ZAA02		632-875 rpm	632-875 rpm
		ZAA03		798-1105 rpm	798-1105 rpm
		ZAA04		921-1228 rpm	921-1228 rpm
	Wheel nominal diameter x width - in.		15 x 9	15 x 9	
<b>Filters</b>	Type		Disposable	Disposable	
	Number and size - in.		(2) 16 x 20 x 2 (2) 20 x 20 x 2	(2) 16 x 20 x 2 (2) 20 x 20 x 2	
<b>Electrical Characteristics - 60 Hz</b>			208/230V, 460V or 575V – 60 hertz 3 phase	208/230V, 460V or 575V – 60 hertz 3 phase	

NOTE - Net capacity includes evaporator blower motor heat deduction. Gross capacity does not include evaporator blower motor heat deduction.

<sup>1, 2</sup> AHRI Certified to AHRI Standard <sup>1</sup> 210/240 or <sup>2</sup> 340/360: 95°F outdoor air temperature and 80°F db/67°F wb entering evaporator air; minimum external duct static pressure.

<sup>3</sup> Sound Rating Number (SRN) rated in accordance with test conditions included in ANSI/AHRI Standard 270-2008.

<sup>4</sup> Using total air volume and system static pressure requirements determine from blower performance tables rpm and motor hp required. Maximum usable hp of motors furnished are shown. In Canada, nominal motor hp is also maximum usable motor hp output. If motors of comparable hp are used, be sure to keep within the service factor limitations outlined on the motor nameplate.

**SPECIFICATIONS - STANDARD GAS HEAT - THREE PHASE MODELS**

Model No.		036, 048, 060	074	036, 048, 060	074	036, 048, 060	074	048, 060	074	048, 060	074
Heat Input Type		Standard (1 Stage)		Medium (1 Stage)		Medium (2 Stage)		High (1 Stage)		High (2 Stage)	
Input Btuh	1st Stage	65,000		108,000		81,000		150,000		113,000	
	2nd Stage	---		---		108,000		---		150,000	
Output Btuh	1st Stage	52,000		86,000		65,000		120,000		90,000	
	2nd Stage	---		---		86,000		---		120,000	
Temperature Rise Range - °F	1st stage	15 - 45	5 - 35	35 - 65	20 - 50	20 - 50	10 - 40	45 - 75	35 - 55	30 - 60	25 - 55
	2nd Stage	---	---	---	---	35 - 65	20 - 50	---	---	45 - 75	35 - 65
<sup>1</sup> Thermal Efficiency	Standard	80%	80%	80%	80%	80%	80%	80%	80%	80%	80%
Gas Supply Connections		1/2 in. NPT									
Rec. Gas Supply Pressure - Nat./ LPG		7 in.w.g. / 11 in.w.g.									

<sup>1</sup> Thermal Efficiency at full input.

**SPECIFICATIONS - LOW NOX GAS HEAT - SINGLE AND THREE PHASE MODELS**

Model No.		036, 048, 060	074	036, 048, 060	074	036, 048, 060	074	048, 060	074	048, 060	074
Heat Input Type		Standard (1 Stage)		Medium (1 Stage)		Medium (2 Stage)		High (1 Stage)		High (2 Stage)	
Input Btuh	1st Stage	65,000		108,000		81,000		150,000		113,000	
	2nd Stage	---		---		108,000		---		150,000	
Output Btuh	1st Stage	52,000		87,000		66,000		121,000		92,000	
	2nd Stage	---		---		87,000		---		121,000	
Temperature Rise Range - °F	1st stage	15 - 45	5 - 35	35 - 65	20 - 50	20 - 50	10 - 40	45 - 75	35 - 65	30 - 60	25 - 55
	2nd Stage	---	---	---	---	35 - 65	20 - 50	---	---	45 - 75	35 - 65
<sup>1</sup> AFUE (single phase)		81%	81%	81%	---	81%	---	81%	---	81%	---
<sup>2</sup> Thermal Efficiency (three phase)		---	81%	81%	81%	81%	81%	81%	81%	81%	81%
Gas Supply Connections		1/2 in. NPT									
Rec. Gas Supply Pressure - Nat./ LPG		7 in.w.g. / 11 in.w.g.									

<sup>1</sup> Annual Fuel Utilization Efficiency based on U.S. DOE test procedures and FTC labeling regulations - 1 phase models only.

<sup>2</sup> Thermal Efficiency at full input.

**HIGH ALTITUDE DERATE**

<p>NOTE - Units may be installed at altitudes up to 2000 ft. above sea level without any modifications. At altitudes above 2000 ft. units must be derated to match information in the table shown. At altitudes above 4500 ft. unit must be derated 2% for each 1000 ft. above sea level. NOTE - This is the only permissible derate for these units.</p>	Heat Input Type	Altitude Feet	Gas Manifold Pressure in. w.g.		Input Rate (Btuh)
			Natural Gas	LPG/ Propane	
	Standard (1 stage)	2001 - 4500	3.0	9.0	60,000
	Medium (1 stage)	2001 - 4500	3.0	9.0	100,000
	Medium (2 stage)	2001 - 4500	3.0/1.7	9.0/5.1	100,000 / 75,000
	High (1 stage)	2001 - 4500	3.0	9.0	139,000
High (2 stage)	2001 - 4500	3.0/1.7	9.0/5.1	139,000 / 104,000	



**BLOWER DATA - ZGB036**

**BLOWER TABLE INCLUDES RESISTANCE FOR BASE UNIT ONLY WITH DRY INDOOR COIL AND AIR FILTERS IN PLACE.**

FOR ALL UNITS ADD:

1 - Any factory installed options air resistance (heat section, economizer, wet coil, etc.).

2 - Any field installed accessories air resistance (duct resistance, diffuser, etc.).

**DOWNFLOW**

Air Volume cfm	External Static - in. w.g.															
	0.10		0.20		0.30		0.40		0.50		0.60		0.70		0.80	
	RPM	BHP	RPM	BHP	RPM	BHP	RPM	BHP	RPM	BHP	RPM	BHP	RPM	BHP	RPM	BHP
900	573	0.16	639	0.18	707	0.19	776	0.21	844	0.23	908	0.25	967	0.27	1022	0.30
1000	600	0.18	665	0.20	733	0.22	802	0.23	868	0.25	930	0.28	986	0.31	1038	0.33
1100	628	0.21	695	0.22	762	0.24	829	0.26	893	0.29	953	0.31	1007	0.35	1057	0.38
1200	660	0.23	727	0.25	794	0.27	859	0.29	921	0.32	977	0.36	1029	0.39	1077	0.42
1300	695	0.26	761	0.28	827	0.31	890	0.33	949	0.37	1003	0.40	1053	0.44	1099	0.47
1400	734	0.30	799	0.32	862	0.35	923	0.38	978	0.41	1030	0.45	1078	0.49	1122	0.53
1500	775	0.34	837	0.37	898	0.40	955	0.43	1009	0.46	1058	0.50	1104	0.54	1147	0.58

Air Volume cfm	External Static - in. w.g.															
	0.90		1.00		1.10		1.20		1.30		1.40		1.50		1.60	
	RPM	BHP	RPM	BHP	RPM	BHP	RPM	BHP	RPM	BHP	RPM	BHP	RPM	BHP	RPM	BHP
900	1072	0.32	1120	0.35	1166	0.38	1210	0.41	1252	0.44	1292	0.47	1331	0.5	1370	0.54
1000	1087	0.36	1134	0.39	1179	0.42	1222	0.45	1263	0.48	1303	0.51	1341	0.55	1379	0.58
1100	1104	0.40	1150	0.43	1194	0.46	1236	0.49	1277	0.53	1315	0.56	1353	0.60	1390	0.64
1200	1123	0.45	1167	0.48	1210	0.51	1251	0.55	1291	0.58	1330	0.62	1367	0.66	1403	0.70
1300	1143	0.50	1186	0.54	1228	0.57	1268	0.60	1308	0.64	1346	0.68	1382	0.72	1418	0.76
1400	1165	0.56	1206	0.59	1247	0.63	1287	0.67	1326	0.70	1363	0.75	1399	0.79	1435	0.83
1500	1188	0.62	1229	0.66	1269	0.69	1308	0.73	1346	0.77	1382	0.82	1418	0.86	1453	0.90

**HORIZONTAL**

Air Volume cfm	External Static - in. w.g.															
	0.10		0.20		0.30		0.40		0.50		0.60		0.70		0.80	
	RPM	BHP	RPM	BHP	RPM	BHP	RPM	BHP	RPM	BHP	RPM	BHP	RPM	BHP	RPM	BHP
900	573	0.14	642	0.16	712	0.18	780	0.21	846	0.23	909	0.26	967	0.28	1022	0.31
1000	599	0.16	668	0.18	737	0.21	804	0.23	868	0.26	928	0.29	984	0.32	1037	0.35
1100	626	0.18	695	0.21	764	0.24	830	0.26	892	0.29	950	0.32	1003	0.36	1053	0.39
1200	656	0.21	726	0.24	794	0.27	858	0.30	918	0.33	973	0.37	1024	0.40	1072	0.43
1300	691	0.25	761	0.28	827	0.31	889	0.34	945	0.38	998	0.41	1047	0.45	1093	0.48
1400	731	0.29	798	0.32	862	0.35	920	0.39	974	0.42	1024	0.46	1071	0.49	1115	0.53
1500	773	0.34	838	0.37	898	0.40	952	0.44	1004	0.47	1051	0.51	1096	0.55	1139	0.58

Air Volume cfm	External Static - in. w.g.															
	0.90		1.00		1.10		1.20		1.30		1.40		1.50		1.60	
	RPM	BHP	RPM	BHP	RPM	BHP	RPM	BHP	RPM	BHP	RPM	BHP	RPM	BHP	RPM	BHP
900	1074	0.33	1123	0.36	1171	0.39	1216	0.41	1260	0.44	1301	0.47	1340	0.49	1378	0.52
1000	1087	0.37	1135	0.40	1181	0.42	1226	0.45	1269	0.48	1310	0.51	1350	0.54	1388	0.57
1100	1101	0.41	1148	0.44	1193	0.47	1237	0.49	1279	0.52	1321	0.55	1360	0.59	1398	0.62
1200	1118	0.46	1163	0.48	1208	0.51	1251	0.54	1293	0.58	1334	0.61	1375	0.64	1414	0.68
1300	1137	0.51	1181	0.53	1224	0.57	1267	0.60	1309	0.63	1350	0.67	1391	0.71	1432	0.75
1400	1158	0.56	1200	0.59	1242	0.62	1284	0.66	1326	0.70	1367	0.74	1407	0.79	1448	0.83
1500	1180	0.61	1222	0.65	1263	0.69	1304	0.73	1345	0.77	1386	0.82	1427	0.87	1467	0.92

**BLOWER DATA - ZGB048**

**BLOWER TABLE INCLUDES RESISTANCE FOR BASE UNIT ONLY WITH DRY INDOOR COIL AND AIR FILTERS IN PLACE.**

FOR ALL UNITS ADD:

- 1 - Any factory installed options air resistance (heat section, economizer, wet coil, etc.).
- 2 - Any field installed accessories air resistance (duct resistance, diffuser, etc.).

**DOWNFLOW**

Air Volume cfm	External Static - in. w.g.															
	0.10		0.20		0.30		0.40		0.50		0.60		0.70		0.80	
	RPM	BHP	RPM	BHP	RPM	BHP	RPM	BHP	RPM	BHP	RPM	BHP	RPM	BHP	RPM	BHP
1200	660	0.23	727	0.25	794	0.27	859	0.29	921	0.32	977	0.36	1029	0.39	1077	0.42
1300	695	0.26	761	0.28	827	0.31	890	0.33	949	0.37	1003	0.40	1053	0.44	1099	0.47
1400	734	0.30	799	0.32	862	0.35	923	0.38	978	0.41	1030	0.45	1078	0.49	1122	0.53
1500	775	0.34	837	0.37	898	0.40	955	0.43	1009	0.46	1058	0.50	1104	0.54	1147	0.58
1600	817	0.39	877	0.42	935	0.45	989	0.48	1040	0.52	1087	0.56	1131	0.60	1173	0.65
1700	859	0.44	917	0.47	972	0.50	1023	0.54	1071	0.58	1117	0.62	1159	0.67	1199	0.71
1800	902	0.49	957	0.53	1008	0.56	1057	0.60	1103	0.64	1147	0.69	1188	0.74	1227	0.79
1900	944	0.56	996	0.59	1045	0.63	1092	0.68	1136	0.72	1178	0.77	1218	0.82	1257	0.87
2000	986	0.63	1035	0.67	1083	0.71	1127	0.76	1170	0.81	1210	0.86	1249	0.91	1287	0.97

Air Volume cfm	External Static - in. w.g.															
	0.90		1.00		1.10		1.20		1.30		1.40		1.50		1.60	
	RPM	BHP	RPM	BHP	RPM	BHP	RPM	BHP	RPM	BHP	RPM	BHP	RPM	BHP	RPM	BHP
1200	1123	0.45	1167	0.48	1210	0.51	1251	0.55	1291	0.58	1330	0.62	1367	0.66	1403	0.70
1300	1143	0.50	1186	0.54	1228	0.57	1268	0.60	1308	0.64	1346	0.68	1382	0.72	1418	0.76
1400	1165	0.56	1206	0.59	1247	0.63	1287	0.67	1326	0.70	1363	0.75	1399	0.79	1435	0.83
1500	1188	0.62	1229	0.66	1269	0.69	1308	0.73	1346	0.77	1382	0.82	1418	0.86	1453	0.90
1600	1213	0.69	1252	0.73	1292	0.77	1330	0.81	1367	0.85	1403	0.89	1438	0.94	1472	0.98
1700	1239	0.76	1278	0.80	1316	0.84	1354	0.89	1390	0.93	1425	0.98	1459	1.02	1492	1.07
1800	1266	0.83	1304	0.88	1342	0.93	1378	0.98	1414	1.02	1448	1.07	1481	1.12	1514	1.16
1900	1294	0.92	1332	0.97	1369	1.02	1404	1.07	1439	1.12	1472	1.17	1504	1.21	1536	1.26
2000	1324	1.02	1360	1.07	1396	1.13	1431	1.18	1465	1.23	1497	1.27	1529	1.32	1560	1.37

**HORIZONTAL**

Air Volume cfm	External Static - in. w.g.															
	0.10		0.20		0.30		0.40		0.50		0.60		0.70		0.80	
	RPM	BHP	RPM	BHP	RPM	BHP	RPM	BHP	RPM	BHP	RPM	BHP	RPM	BHP	RPM	BHP
1200	656	0.21	726	0.24	794	0.27	858	0.30	918	0.33	973	0.37	1024	0.40	1072	0.43
1300	691	0.25	761	0.28	827	0.31	889	0.34	945	0.38	998	0.41	1047	0.45	1093	0.48
1400	731	0.29	798	0.32	862	0.35	920	0.39	974	0.42	1024	0.46	1071	0.49	1115	0.53
1500	773	0.34	838	0.37	898	0.40	952	0.44	1004	0.47	1051	0.51	1096	0.55	1139	0.58
1600	817	0.39	878	0.42	934	0.46	985	0.49	1034	0.53	1080	0.56	1123	0.60	1164	0.64
1700	861	0.45	918	0.48	970	0.51	1018	0.55	1065	0.58	1108	0.62	1150	0.66	1190	0.70
1800	904	0.51	957	0.54	1006	0.57	1052	0.61	1096	0.65	1138	0.69	1178	0.73	1217	0.78
1900	946	0.57	996	0.61	1042	0.64	1086	0.68	1128	0.72	1168	0.76	1207	0.81	1245	0.86
2000	988	0.64	1035	0.68	1079	0.72	1120	0.76	1161	0.81	1199	0.85	1237	0.90	1275	0.96

Air Volume cfm	External Static - in. w.g.															
	0.90		1.00		1.10		1.20		1.30		1.40		1.50		1.60	
	RPM	BHP	RPM	BHP	RPM	BHP	RPM	BHP	RPM	BHP	RPM	BHP	RPM	BHP	RPM	BHP
1200	1118	0.46	1163	0.48	1208	0.51	1251	0.54	1293	0.58	1334	0.61	1375	0.64	1414	0.68
1300	1137	0.51	1181	0.53	1224	0.57	1267	0.60	1309	0.63	1350	0.67	1391	0.71	1432	0.75
1400	1158	0.56	1200	0.59	1242	0.62	1284	0.66	1326	0.70	1367	0.74	1407	0.79	1448	0.83
1500	1180	0.61	1222	0.65	1263	0.69	1304	0.73	1345	0.77	1386	0.82	1427	0.87	1467	0.92
1600	1204	0.68	1245	0.72	1285	0.76	1325	0.80	1366	0.85	1406	0.90	1447	0.96	1487	1.02
1700	1229	0.75	1269	0.79	1309	0.84	1348	0.89	1388	0.94	1428	1.00	1468	1.06	1508	1.12
1800	1256	0.83	1295	0.88	1334	0.93	1373	0.98	1412	1.04	1451	1.10	1490	1.16	1529	1.23
1900	1283	0.92	1322	0.97	1360	1.03	1398	1.09	1436	1.15	1474	1.21	1511	1.27	1549	1.34
2000	1312	1.02	1350	1.07	1387	1.13	1424	1.20	1461	1.26	1498	1.32	1535	1.38	1571	1.45



**BLOWER DATA - ZGB060**

**BLOWER TABLE INCLUDES RESISTANCE FOR BASE UNIT ONLY WITH DRY INDOOR COIL AND AIR FILTERS IN PLACE.**

FOR ALL UNITS ADD:

1 - Any factory installed options air resistance (heat section, economizer, wet coil, etc.).

2 - Any field installed accessories air resistance (duct resistance, diffuser, etc.).

**DOWNFLOW**

Air Volume cfm	External Static - in. w.g.															
	0.10		0.20		0.30		0.40		0.50		0.60		0.70		0.80	
	RPM	BHP	RPM	BHP	RPM	BHP	RPM	BHP	RPM	BHP	RPM	BHP	RPM	BHP	RPM	BHP
1600	848	0.48	905	0.53	961	0.57	1015	0.61	1064	0.66	1107	0.69	1148	0.73	1189	0.76
1700	898	0.56	952	0.60	1005	0.65	1054	0.69	1099	0.73	1140	0.77	1180	0.80	1221	0.83
1800	948	0.63	998	0.68	1047	0.73	1093	0.78	1136	0.82	1175	0.85	1214	0.88	1255	0.91
1900	996	0.72	1042	0.77	1088	0.82	1132	0.86	1173	0.90	1211	0.94	1250	0.97	1290	1.00
2000	1041	0.81	1084	0.86	1128	0.91	1170	0.95	1210	0.99	1249	1.03	1287	1.06	1326	1.10
2100	1084	0.91	1126	0.95	1168	1.00	1209	1.04	1249	1.08	1287	1.12	1324	1.17	1362	1.21
2200	1128	1.01	1169	1.05	1210	1.10	1250	1.14	1288	1.19	1326	1.23	1363	1.28	1399	1.34
2300	1173	1.11	1214	1.16	1253	1.20	1292	1.25	1329	1.30	1366	1.36	1402	1.42	1437	1.48
2400	1220	1.23	1259	1.28	1297	1.33	1335	1.38	1371	1.44	1406	1.50	1442	1.57	1476	1.63

Air Volume cfm	External Static - in. w.g.															
	0.90		1.00		1.10		1.20		1.30		1.40		1.50		1.60	
	RPM	BHP	RPM	BHP	RPM	BHP	RPM	BHP	RPM	BHP	RPM	BHP	RPM	BHP	RPM	BHP
1600	1232	0.79	1274	0.82	1316	0.86	1356	0.90	1395	0.94	1433	0.99	1470	1.04	1506	1.09
1700	1263	0.86	1304	0.90	1344	0.94	1383	0.99	1421	1.04	1458	1.09	1494	1.14	1530	1.19
1800	1295	0.95	1335	0.99	1374	1.04	1412	1.09	1448	1.14	1484	1.20	1520	1.25	1556	1.30
1900	1329	1.04	1368	1.09	1405	1.15	1441	1.20	1477	1.26	1513	1.31	1548	1.37	1583	1.42
2000	1364	1.15	1401	1.21	1437	1.27	1472	1.33	1507	1.38	1543	1.44	1578	1.49	1613	1.54
2100	1399	1.27	1435	1.33	1470	1.40	1505	1.46	1539	1.51	1574	1.56	1609	1.61	1645	1.66
2200	1435	1.40	1470	1.47	1504	1.53	1538	1.59	1573	1.65	1608	1.70	1642	1.74	1678	1.79
2300	1472	1.54	1506	1.61	1540	1.67	1574	1.73	1608	1.78	1642	1.83	1677	1.88	1712	1.93
2400	1510	1.7	1544	1.76	1577	1.82	1610	1.88	1644	1.93	1678	1.97	1713	2.02	1748	2.07

**HORIZONTAL**

Air Volume cfm	External Static - in. w.g.															
	0.10		0.20		0.30		0.40		0.50		0.60		0.70		0.80	
	RPM	BHP	RPM	BHP	RPM	BHP	RPM	BHP	RPM	BHP	RPM	BHP	RPM	BHP	RPM	BHP
1600	761	0.43	820	0.47	879	0.52	937	0.56	994	0.61	1045	0.65	1090	0.69	1132	0.72
1700	803	0.49	861	0.53	918	0.58	973	0.63	1025	0.67	1072	0.72	1114	0.75	1155	0.78
1800	846	0.56	901	0.60	955	0.65	1008	0.70	1056	0.75	1099	0.79	1140	0.82	1181	0.85
1900	889	0.63	941	0.68	993	0.73	1042	0.78	1087	0.83	1129	0.87	1168	0.90	1209	0.93
2000	933	0.71	981	0.76	1030	0.81	1076	0.86	1119	0.91	1159	0.95	1198	0.98	1238	1.01
2100	974	0.79	1020	0.85	1065	0.90	1109	0.96	1151	1.00	1190	1.04	1229	1.07	1268	1.11
2200	1013	0.89	1057	0.94	1100	0.99	1143	1.05	1183	1.09	1222	1.13	1261	1.17	1299	1.21
2300	1050	0.99	1093	1.04	1135	1.09	1177	1.14	1217	1.18	1255	1.23	1293	1.27	1331	1.32
2400	1088	1.09	1129	1.14	1170	1.19	1211	1.23	1250	1.28	1289	1.33	1326	1.38	1363	1.44

Air Volume cfm	External Static - in. w.g.															
	0.90		1.00		1.10		1.20		1.30		1.40		1.50		1.60	
	RPM	BHP	RPM	BHP	RPM	BHP	RPM	BHP	RPM	BHP	RPM	BHP	RPM	BHP	RPM	BHP
1600	1175	0.76	1218	0.79	1260	0.82	1302	0.85	1343	0.89	1383	0.93	1421	0.98	1458	1.03
1700	1198	0.82	1241	0.85	1283	0.89	1324	0.93	1364	0.97	1402	1.02	1439	1.07	1476	1.12
1800	1223	0.89	1265	0.92	1307	0.96	1347	1.01	1386	1.06	1423	1.11	1459	1.16	1495	1.21
1900	1250	0.96	1292	1.01	1332	1.05	1371	1.10	1408	1.15	1445	1.21	1481	1.27	1516	1.32
2000	1279	1.05	1319	1.10	1358	1.15	1396	1.20	1432	1.26	1468	1.32	1504	1.38	1539	1.44
2100	1308	1.15	1347	1.20	1385	1.26	1421	1.32	1457	1.38	1493	1.44	1528	1.50	1563	1.56
2200	1338	1.26	1376	1.31	1412	1.38	1448	1.45	1483	1.51	1518	1.57	1553	1.63	1588	1.68
2300	1368	1.37	1405	1.44	1441	1.51	1476	1.58	1510	1.64	1545	1.70	1580	1.76	1615	1.81
2400	1400	1.50	1435	1.57	1470	1.65	1505	1.72	1539	1.78	1573	1.84	1608	1.89	1643	1.94

**BLOWER DATA - ZGB074**

**BLOWER TABLE INCLUDES RESISTANCE FOR BASE UNIT ONLY WITH DRY INDOOR COIL AND AIR FILTERS IN PLACE.**

FOR ALL UNITS ADD:

- 1 - Any factory installed options air resistance (heat section, economizer, wet coil, etc.).
- 2 - Any field installed accessories air resistance (duct resistance, diffuser, etc.).

**DOWNFLOW**

Air Volume cfm	External Static - in. w.g.															
	0.10		0.20		0.30		0.40		0.50		0.60		0.70		0.80	
	RPM	BHP	RPM	BHP	RPM	BHP	RPM	BHP	RPM	BHP	RPM	BHP	RPM	BHP	RPM	BHP
1900	578	0.44	610	0.49	643	0.54	678	0.60	714	0.65	749	0.70	785	0.76	819	0.82
2000	600	0.50	632	0.56	665	0.61	699	0.66	734	0.71	769	0.77	803	0.83	837	0.90
2100	623	0.57	655	0.62	688	0.68	721	0.73	755	0.79	789	0.84	822	0.91	854	0.98
2200	647	0.65	678	0.70	711	0.75	743	0.81	776	0.86	809	0.93	841	1.00	872	1.06
2300	671	0.73	702	0.78	734	0.83	766	0.89	798	0.95	829	1.02	860	1.09	890	1.16
2400	696	0.81	726	0.87	757	0.92	788	0.98	819	1.04	850	1.11	880	1.19	909	1.26
2500	720	0.90	750	0.95	780	1.01	811	1.07	841	1.14	871	1.22	900	1.30	929	1.37
2600	745	0.99	774	1.05	804	1.11	834	1.17	864	1.25	893	1.33	921	1.41	949	1.49
2700	770	1.09	799	1.15	828	1.21	858	1.28	887	1.36	916	1.44	943	1.53	969	1.61
2800	795	1.19	824	1.25	853	1.33	882	1.40	911	1.48	939	1.56	965	1.65	990	1.73
2900	820	1.30	849	1.37	878	1.45	907	1.53	935	1.61	962	1.70	988	1.78	1012	1.86

Air Volume cfm	External Static - in. w.g.															
	0.90		1.00		1.10		1.20		1.30		1.40		1.50		1.60	
	RPM	BHP	RPM	BHP	RPM	BHP	RPM	BHP	RPM	BHP	RPM	BHP	RPM	BHP	RPM	BHP
1900	853	0.88	885	0.94	915	0.99	944	1.05	971	1.11	996	1.17	1021	1.23	1045	1.29
2000	869	0.96	899	1.01	929	1.07	957	1.13	984	1.19	1009	1.25	1033	1.31	1058	1.38
2100	885	1.04	915	1.10	944	1.15	971	1.22	997	1.28	1022	1.34	1046	1.40	1070	1.46
2200	902	1.13	931	1.19	959	1.24	986	1.31	1012	1.37	1036	1.43	1060	1.50	1084	1.56
2300	920	1.23	948	1.29	975	1.35	1001	1.41	1027	1.47	1051	1.53	1075	1.60	1098	1.66
2400	938	1.33	965	1.39	992	1.45	1017	1.52	1042	1.58	1066	1.64	1090	1.70	1113	1.77
2500	956	1.44	983	1.51	1009	1.57	1034	1.63	1059	1.69	1082	1.75	1105	1.82	1128	1.88
2600	975	1.56	1001	1.63	1026	1.69	1051	1.75	1075	1.81	1098	1.87	1121	1.93	1143	2.00
2700	995	1.68	1020	1.75	1044	1.81	1069	1.87	1092	1.93	1114	1.99	1136	2.06	1158	2.13
2800	1015	1.81	1039	1.87	1063	1.94	1086	2.00	1109	2.06	1131	2.12	1152	2.19	1174	2.26
2900	1035	1.94	1058	2.00	1081	2.07	1104	2.13	1126	2.19	1147	2.26	1168	2.33	1189	2.40

**HORIZONTAL**

Air Volume cfm	External Static - in. w.g.															
	0.10		0.20		0.30		0.40		0.50		0.60		0.70		0.80	
	RPM	BHP	RPM	BHP	RPM	BHP	RPM	BHP	RPM	BHP	RPM	BHP	RPM	BHP	RPM	BHP
1900	581	0.44	618	0.49	655	0.54	692	0.59	729	0.64	765	0.69	800	0.75	833	0.80
2000	602	0.50	639	0.55	676	0.61	713	0.66	749	0.71	784	0.76	818	0.82	850	0.88
2100	625	0.57	661	0.62	698	0.67	735	0.73	770	0.78	804	0.84	837	0.90	868	0.96
2200	648	0.64	685	0.69	721	0.75	757	0.80	791	0.86	824	0.92	856	0.98	886	1.05
2300	673	0.71	709	0.77	745	0.83	780	0.88	813	0.94	845	1.01	876	1.08	905	1.15
2400	699	0.79	734	0.85	769	0.91	803	0.97	835	1.04	866	1.11	896	1.18	924	1.25
2500	725	0.88	759	0.94	793	1.00	826	1.07	857	1.14	887	1.21	916	1.28	944	1.36
2600	752	0.97	785	1.04	818	1.10	850	1.17	880	1.25	909	1.32	937	1.40	964	1.48
2700	779	1.07	811	1.14	843	1.21	873	1.29	902	1.37	931	1.44	958	1.52	984	1.60
2800	805	1.18	837	1.26	868	1.33	897	1.41	925	1.49	952	1.57	979	1.66	1004	1.74
2900	832	1.30	863	1.38	892	1.46	921	1.54	948	1.63	974	1.71	1000	1.80	1024	1.88

Air Volume cfm	External Static - in. w.g.															
	0.90		1.00		1.10		1.20		1.30		1.40		1.50		1.60	
	RPM	BHP	RPM	BHP	RPM	BHP	RPM	BHP	RPM	BHP	RPM	BHP	RPM	BHP	RPM	BHP
1900	864	0.87	895	0.93	924	0.99	953	1.06	980	1.12	1007	1.18	1032	1.25	1056	1.31
2000	881	0.95	911	1.01	940	1.08	967	1.14	994	1.21	1020	1.27	1044	1.34	1068	1.40
2100	898	1.03	927	1.10	955	1.17	982	1.23	1008	1.30	1033	1.37	1057	1.43	1080	1.50
2200	916	1.12	944	1.19	971	1.26	998	1.33	1023	1.40	1047	1.47	1071	1.54	1093	1.60
2300	934	1.22	961	1.29	988	1.36	1014	1.43	1038	1.50	1062	1.58	1085	1.65	1107	1.71
2400	952	1.32	979	1.40	1005	1.47	1030	1.54	1054	1.62	1077	1.69	1099	1.76	1121	1.83
2500	971	1.43	997	1.51	1022	1.59	1046	1.66	1069	1.74	1092	1.81	1114	1.88	1135	1.95
2600	990	1.55	1015	1.63	1039	1.71	1063	1.79	1086	1.86	1108	1.94	1129	2.01	1150	2.07
2700	1009	1.68	1034	1.76	1057	1.84	1080	1.92	1102	1.99	1124	2.07	1145	2.14	1166	2.21
2800	1028	1.82	1052	1.9	1075	1.98	1097	2.06	1119	2.13	1140	2.21	1161	2.28	1182	2.34
2900	1048	1.96	1071	2.04	1093	2.12	1115	2.20	1136	2.28	1157	2.35	1177	2.42	1198	2.48

**BLOWER DATA**

**BELT DRIVE KIT SPECIFICATIONS - ZGB036-060**

Model No.	Motor HP		No. of Speeds	Drive Kits and RPM Range					
	Nominal	Maximum		ZA01	ZA02	ZA03	ZA04	<sup>3</sup> ZA05	<sup>3</sup> ZA06
ZGB036	<sup>1</sup> 0.75	0.86	1	678 - 1035	---	---	964 - 1471	---	---
	<sup>2</sup> 1	1.15	1	678 - 1035	---	---	964 - 1471	---	---
	<sup>1</sup> 1.5	1.7	1	678 - 1035	---	---	964 - 1471	---	---
ZGB048	<sup>1</sup> 0.75	0.86	1	---	803 - 1226	---	---	---	---
	<sup>2</sup> 1	1.15	1	---	803 - 1226	---	---	---	---
	<sup>1</sup> 1.5	1.7	1	---	803 - 1226	---	---	1098 - 1490	---
ZGB060	<sup>1</sup> 0.75	0.86	1	---	---	906 - 1383	---	---	---
	<sup>2</sup> 1	1.15	1	---	---	906 - 1383	---	---	---
	<sup>1</sup> 1.5	1.7	1	---	---	906 - 1383	---	---	1262 - 1634

**BELT DRIVE KIT SPECIFICATIONS - ZGB074**

Model No.	Motor HP		No. of Speeds	Drive Kits and RPM Range		
	Nominal	Maximum		ZAA02	ZAA03	<sup>4</sup> ZAA04
ZGB074S4B	1.5	1.7	1	632 - 875	798 - 1105	---
	2	2.3	1	632 - 875	798 - 1105	921 - 1228
ZGB074S4T	2	2.3	2	632 - 875	798 - 1105	921 - 1228

NOTE - Using total air volume and system static pressure requirements determine from blower performance tables rpm and motor hp required. Maximum usable hp of motors furnished are shown. In Canada, nominal motor hp is also maximum usable motor hp. If motors of comparable hp are used, be sure to keep within the service factor limitations outlined on the motor nameplate.

<sup>1</sup> 0.75 and 1.5 hp motors are only available for ZGB 208/230V-1ph applications.

<sup>2</sup> 1 hp blower motor is not available for ZGB 208/230V-1ph applications.

<sup>3</sup> 1.5 hp blower motor is required with the ZA05 and ZA06 drive kits.

<sup>4</sup> 2 hp blower motor is required with the ZAA04 drive kit.

**POWER EXHAUST FAN PERFORMANCE**

Return Air System Static Pressure - in. w.g.	Air Volume Exhausted cfm
0.00	1865
0.05	1785
0.10	1710
0.15	1630
0.20	1545
0.25	1450
0.30	1350
0.35	1240

## BLOWER DATA

### OPTIONS / ACCESSORIES AIR RESISTANCE - in. w.g.

Air Volume cfm	Wet Indoor Coil		Gss Heat Exchanger		Economizer	
	ZGB036, ZGB048	ZGB060, ZGB074	Medium	High	Downflow	Horizontal
900	0.01	---	0.05	0.06	0.03	0.04
1000	0.02	---	0.06	0.06	0.03	0.05
1100	0.02	---	0.06	0.07	0.04	0.05
1200	0.02	---	0.06	0.07	0.05	0.06
1300	0.03	---	0.07	0.07	0.05	0.07
1400	0.03	---	0.07	0.08	0.06	0.08
1500	0.04	---	0.07	0.08	0.07	0.08
1600	0.04	0.03	0.07	0.08	0.08	0.09
1700	0.05	0.03	0.07	0.08	0.09	0.10
1800	0.05	0.03	0.06	0.08	0.10	0.11
1900	0.06	0.04	0.06	0.08	0.11	0.12
2000	0.06	0.04	0.07	0.09	0.12	0.13
2100	---	0.05	0.08	0.10	0.13	0.14
2200	---	0.05	0.10	0.12	0.14	0.15
2300	---	0.05	0.11	0.14	0.15	0.16
2400	---	0.06	0.11	0.13	0.16	0.18
2500	---	0.06	0.11	0.15	0.18	0.19
2600	---	0.07	0.13	0.16	0.19	0.20
2700	---	0.07	0.15	0.18	0.20	0.21
2800	---	0.07	0.13	0.16	0.22	0.23
2900	---	0.08	0.13	0.18	0.23	0.24

## OUTDOOR SOUND DATA

Unit Model No.	Octave Band Linear Sound Power Levels dB, re 10 <sup>-12</sup> Watts - Center Frequency - Hz							1 Sound Rating Number (SRN) (dBA)
	125	250	500	1000	2000	4000	8000	
<b>ZGB036</b>	66	70	73	72	70	67	60	78
<b>ZGB048</b>	68	71	75	74	71	68	63	80
<b>ZGB060</b>	64	68	72	73	69	67	63	78
<b>ZGB074</b>	73	76	80	78	73	68	66	84

<sup>1</sup> Sound Rating Number according to ANSI/AHRI Standard 270-2008. "SRN" is the overall A-Weighted Sound Power Level, (LWA), dB (100 Hz to 10,000 Hz).

## BLOWER DATA

### CEILING DIFFUSERS AIR RESISTANCE (in. w.g.)

Air Volume cfm	RTD9-65S Step-Down Diffuser			FD9-65S Flush Diffuser	RTD11-95S Step-Down Diffuser			FD11-95S Flush Diffuser
	2 Ends Open	1 Side & 2 Ends Open	All Ends & Sides Open		2 Ends Open	1 Side & 2 Ends Open	All Ends & Sides Open	
800	0.15	0.13	0.11	0.11	---	---	---	---
1000	0.19	0.16	0.14	0.14	---	---	---	---
1200	0.25	0.20	0.17	0.17	---	---	---	---
1400	0.33	0.26	0.20	0.20	---	---	---	---
1600	0.43	0.32	0.20	0.24	---	---	---	---
1800	0.56	0.40	0.30	0.30	0.13	0.11	0.09	0.09
2000	0.73	0.50	0.36	0.36	0.15	0.13	0.11	0.10
2200	0.95	0.63	0.44	0.44	0.18	0.15	0.12	0.12
2400	---	----	---	---	0.21	0.18	0.15	0.14
2600	---	----	---	---	0.24	0.21	0.18	0.17
2800	---	----	---	---	0.27	0.24	0.21	0.20
3000	---	----	---	---	0.32	0.29	0.25	0.25
3200	---	----	---	---	0.41	0.37	0.32	0.31
3400	---	----	---	---	0.50	0.45	0.39	0.37
3600	---	----	---	---	0.61	0.54	0.48	0.44

### CEILING DIFFUSER AIR THROW DATA

Air Volume - cfm	<sup>1</sup> Effective Throw - ft.		Air Volume - cfm	<sup>1</sup> Effective Throw - ft.	
Model No.	RTD9-65S	FD9-65S	Model No.	RTD11-95S	FD11-95S
800	10 - 17	14 - 18	2600	24 - 29	19 - 24
1000	10 - 17	15 - 20	2800	25 - 30	20 - 28
1200	11 - 18	16 - 22	3000	27 - 33	21 - 29
1400	12 - 19	17 - 24	3200	28 - 35	22 - 29
1600	12 - 20	18 - 25	3400	30 - 37	22 - 30
1800	13 - 21	20 - 28	3600	25 - 33	22 - 24
2000	14 - 23	21 - 29			
2200	16 - 25	22 - 30			

<sup>1</sup> Effective throw based on terminal velocities of 75 ft. per minute.

## ELECTRICAL DATA

3 TON

**ZGB036S4**

<sup>1</sup> Voltage - 60hz		208/230V - 1 Ph		208/230V - 3 Ph		460V - 3 Ph		575V - 3 Ph	
Compressor	Rated Load Amps	15.3		8.7		4		3.6	
	Locked Rotor Amps	70		70		31		27	
Outdoor Fan Motor	Full Load Amps	1.7		1.7		0.9		0.7	
Power Exhaust (1) 0.5 HP	Full Load Amps	1.5		1.5		0.6		0.6	
Indoor Blower Motor	Horsepower	0.75	1.5	1	1.5	1	1.5	1	1.5
	Full Load Amps	7.6	11	4.6	6.6	2.1	3	1.7	2.4
<sup>2</sup> Maximum Overcurrent Protection	Unit Only	40	45	25	25	15	15	15	15
	With (1) 0.5 HP Power Exhaust	45	45	25	25	15	15	15	15
<sup>3</sup> Minimum Circuit Ampacity	Unit Only	29	32	18	20	8	9	7	8
	With (1) 0.5 HP Power Exhaust	30	34	19	21	9	10	8	9

## ELECTRICAL DATA

4 TON

**ZGB048S4**

<sup>1</sup> Voltage - 60hz		208/230V - 1 Ph		208/230V - 3 Ph		460V - 3 Ph		575V - 3 Ph	
Compressor	Rated Load Amps	20		11		5.5		4.7	
	Locked Rotor Amps	99		86		37		34	
Outdoor Fan Motor	Full Load Amps	1.7		1.7		0.9		0.7	
Power Exhaust (1) 0.5 HP	Full Load Amps	1.5		1.5		0.6		0.6	
Indoor Blower Motor	Horsepower	0.75	1.5	1	1.5	1	1.5	1	1.5
	Full Load Amps	7.6	11	4.6	6.6	2.1	3	1.7	2.4
<sup>2</sup> Maximum Overcurrent Protection	Unit Only	50	50	30	30	15	15	15	15
	With (1) 0.5 HP Power Exhaust	50	50	30	30	15	15	15	15
<sup>3</sup> Minimum Circuit Ampacity	Unit Only	35	38	21	23	10	11	9	9
	With (1) 0.5 HP Power Exhaust	36	40	22	24	11	12	9	10

## ELECTRICAL DATA

5 TON

**ZGB060S4**

<sup>1</sup> Voltage - 60hz		208/230V - 1 Ph		208/230V - 3 Ph		460V - 3 Ph		575V - 3 Ph	
Compressor	Rated Load Amps	22.1		13.5		8		5	
	Locked Rotor Amps	125		109		59		40	
Outdoor Fan Motor	Full Load Amps	1.7		1.7		0.9		0.7	
Power Exhaust (1) 0.5 HP	Full Load Amps	1.5		1.5		0.6		0.6	
Indoor Blower Motor	Horsepower	0.75	1.5	1	1.5	1	1.5	1	1.5
	Full Load Amps	7.6	11	4.6	6.6	2.1	3	1.7	2.4
<sup>2</sup> Maximum Overcurrent Protection	Unit Only	50	60	35	35	20	20	15	15
	With (1) 0.5 HP Power Exhaust	60	60	35	40	20	20	15	15
<sup>3</sup> Minimum Circuit Ampacity	Unit Only	37	41	24	26	13	14	9	10
	With (1) 0.5 HP Power Exhaust	39	42	25	27	14	15	10	10

NOTE - All units have a minimum Short Circuit Current Rating (SCCR) of 5000 amps.

<sup>1</sup> Extremes of operating range are plus and minus 10% of line voltage.<sup>2</sup> HACR type breaker or fuse.<sup>3</sup> Refer to National or Canadian Electrical Code manual to determine wire, fuse and disconnect size requirements.



## ELECTRICAL DATA

6 TON

**ZGB074S4B**

<sup>1</sup> Voltage - 60hz		208/230V - 3 Ph	460V - 3 Ph	575V - 3 Ph
Compressor	Rated Load Amps	17.6	8.5	6.3
	Locked Rotor Amps	136	66.1	55.3
Outdoor Fan Motor	Full Load Amps	1.7	1	0.9
Power Exhaust (1) 0.5 HP	Full Load Amps	1.5	0.6	0.6
Indoor Blower Motor	Horsepower	2	2	2
	Full Load Amps	7.5	3.4	2.7
<sup>2</sup> Maximum Overcurrent Protection	Unit Only	45	20	15
	With (1) 0.5 HP Power Exhaust	50	20	15
<sup>3</sup> Minimum Circuit Ampacity	Unit Only	32	16	12
	With (1) 0.5 HP Power Exhaust	33	16	13

NOTE - All units have a minimum Short Circuit Current Rating (SCCR) of 5000 amps.

<sup>1</sup> Extremes of operating range are plus and minus 10% of line voltage.<sup>2</sup> HACR type breaker or fuse.<sup>3</sup> Refer to National or Canadian Electrical Code manual to determine wire, fuse and disconnect size requirements.

## ELECTRICAL DATA

6 TON

**ZGB074S4T**

<sup>1</sup> Voltage - 60hz		208/230V - 3 Ph	460V - 3 Ph	575V - 3 Ph
Compressor	Rated Load Amps	17.6	8.5	6.3
	Locked Rotor Amps	136	66.1	55.3
Outdoor Fan Motor	Full Load Amps	1.7	1	0.9
Power Exhaust (1) 0.5 HP	Full Load Amps	2.4	1.3	1
Indoor Blower Motor	Horsepower	2	2	2
	Full Load Amps	7.5	3.4	2.7
<sup>2</sup> Maximum Overcurrent Protection	Unit Only	45	20	15
	With (1) 0.5 HP Power Exhaust	50	20	15
<sup>3</sup> Minimum Circuit Ampacity	Unit Only	32	16	12
	With (1) 0.5 HP Power Exhaust	34	17	13

NOTE - All units have a minimum Short Circuit Current Rating (SCCR) of 5000 amps.

<sup>1</sup> Extremes of operating range are plus and minus 10% of line voltage.<sup>2</sup> HACR type breaker or fuse.<sup>3</sup> Refer to National or Canadian Electrical Code manual to determine wire, fuse and disconnect size requirements.

## ZGB PARTS ARRANGEMENT

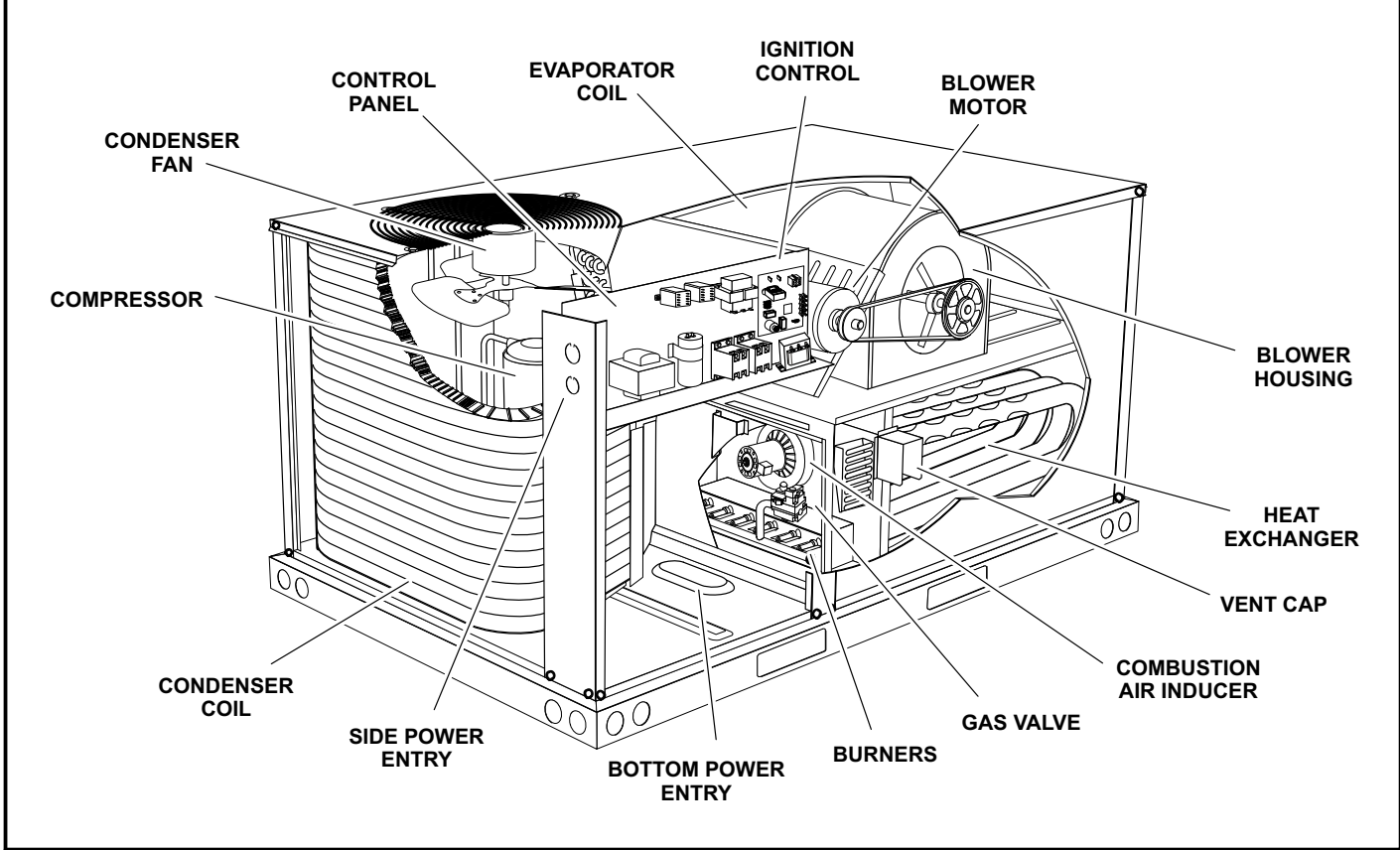

FIGURE 1

## ZGB CONTROL BOX

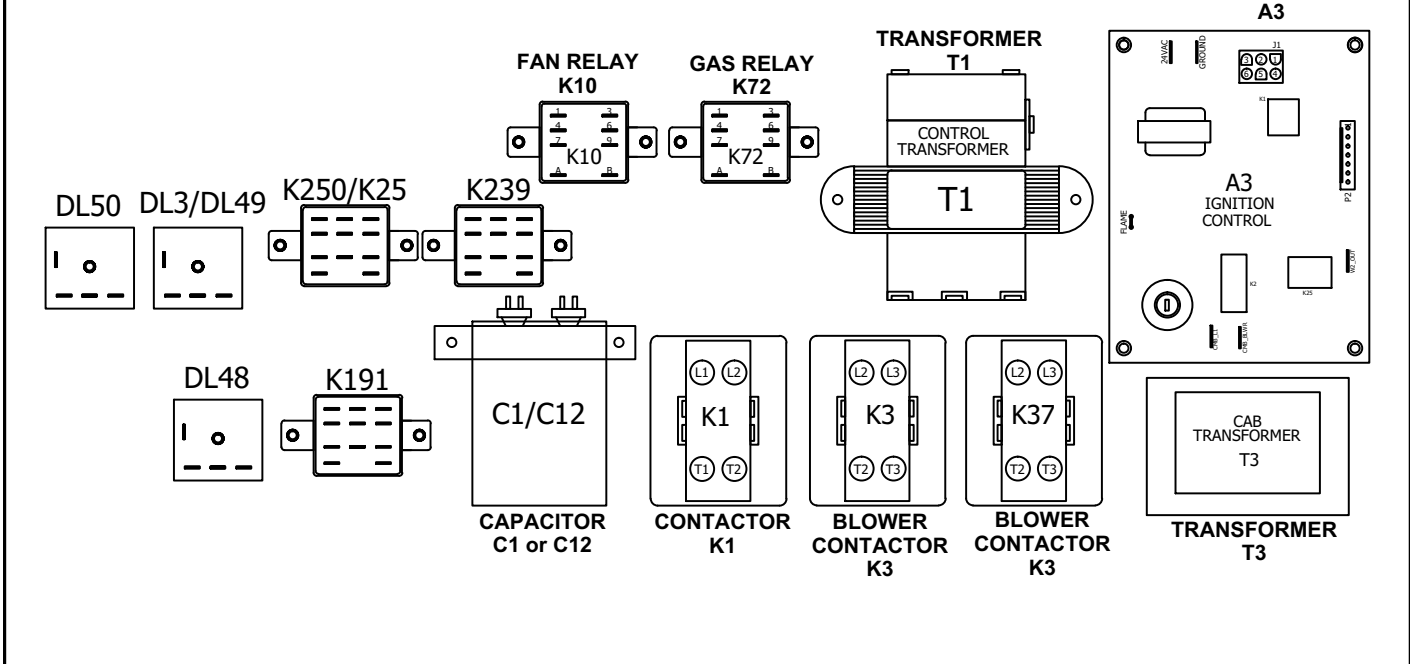

FIGURE 2

## I-UNIT COMPONENTS

The ZGB unit components are shown in figure 1. All units come standard with removable unit panels. All L1, L2, and L3 wiring is color coded; L1 is red, L2 is yellow, and L3 is blue.

### A-Control Box Components

ZGB control box components are shown in figure 2. The control box is in the outdoor section to the left of the blower and heat section.

#### 1-Control Transformer T1

All use a single line voltage to 24VAC transformer mounted in the control box. Transformer supplies power to control circuits in the unit. The transformer is rated at 70VA and is protected by a 3 amp (auto) fuse F1. The 208/230 (Y) voltage transformers use two primary voltage

age taps as shown in figure 3, while 460 (G) and 575 (J) voltage transformers use a single primary voltage tap.

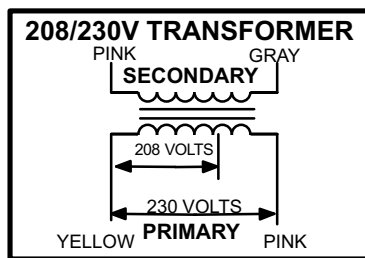

FIGURE 3

#### 2-C. A. I. Transformers T3 (G, J voltage)

All (G) 460 and 575 (J) voltage units use transformer T3 mounted in the control box. The transformers have an output rating of 0.75A. T3 transformer supplies 230 VAC power to the combustion air inducer motor (B6).

#### 3-Fan Capacitor C1 (three phase)

Fan capacitors C1 is used to assist in the start up of condenser fan B4. Ratings will be on side of capacitor or outdoor fan motor nameplate.

#### 4-Dual Capacitor C12 (single phase)

A single dual capacitor is used for both the outdoor fan and compressor (see unit diagram). The fan side and the compressor side have different MFD ratings. See side of capacitor for ratings.

#### 5-Compressor Contactor K1

In all ZGB units, K1 energizes compressors B1 in response to thermostat demand. Three phase units use two pole double break contactors with a 24 volt coil. Single phase units use single pole double break contactors with a 24 volt coil.

#### 6-Blower Contactor K3

On three phase units, K3 is a two pole double-break contactor with a 24VAC coil and on single phase units is a single pole double break contactor with a 24 volt coil. K3 energizes the indoor blower motor B3 in response to blower demand.

#### 7-Condenser Fan Relay K10 (G, J voltage)

Outdoor fan relay K10 is an optional, field-installed DPDT relay with a 24VAC coil. K10 relay coil is in series with S11 low ambient pressure switch and cycles B4 outdoor fan via K10-1 n.o. contacts.

#### 8-Crankcase Heater Delay DL48 & Crankcase Heater Relay K191

Delay DL48 and relay K191 keep crankcase heater de-energized during and immediately following compressor shut down. They ensure the crankcase heater is off while compressor is energized.

#### 9-Gas Relay K72 (two-stage units)

Relay K72 is a DPDT relay which controls combustion air blower B6 on two-stage gas heat units.

#### 10-Relay K239 (-074 Units)

Relay K239 sends the Y1 demand "G" signal to K3 (through K250) to energize the blower on low speed and also sends the "W1" demand "G" signal to K37 (through K250) to energize the blower on high speed.

#### 11-Relay K250 (-074 Units)

Relay K250 passes the "G" signal to contactor K3 energizing the blower on low speed. On a Y2 call K250 passes the signal to K37 energizing the blower on high speed and internal solenoid L34 energizing the compressor on high speed.

#### 12-Blower Contactor K37 (-074 Units)

On two-speed operation K37 acts as the high speed blower contactor and K3 acts as the low speed contactor in response to blower demand.

#### 13-Blower Delay DL3 &DL50 (-074 Units)

When second stage heat demand is satisfied DL3 causes a 180 second blower off delay.

DL50 causes a 1.5 second delay switching from high speed to low speed.

## 14-Burner Control A3

⚠ WARNING



**Shock hazard. Spark related components contain high voltage which can cause personal injury or death. Disconnect power before servicing. Control is not field repairable. Unsafe operation will result. If control is inoperable, simply replace the entire control.**

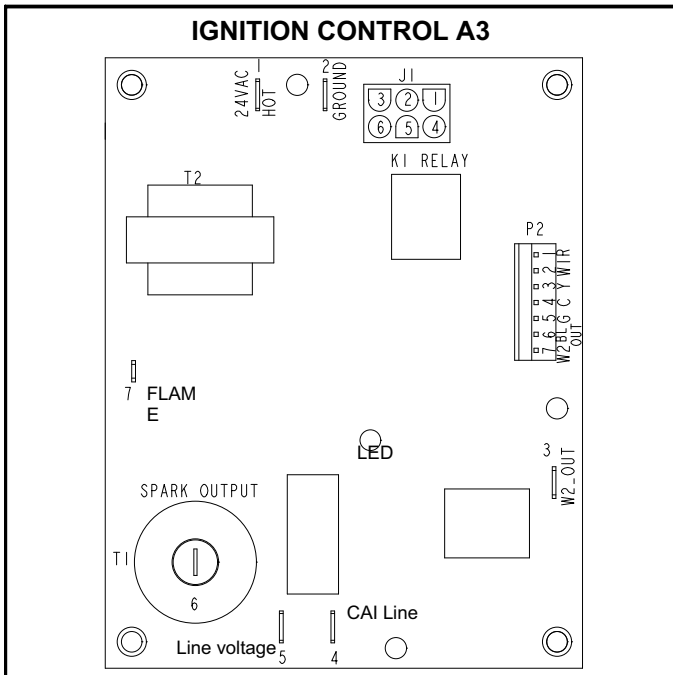

**FIGURE 4**

The main control box (see figure 2) houses the burner control A3.

The ignition control provides four main functions: gas valve control, blower control, ignition, and flame sensing. The control has a green LED to show control status (table 1). The unit will usually ignite on the first trial and A3 allows three trials for ignition before locking out. The lockout time is 1 hour. After lockout, the ignition control automatically resets and provides three more attempts at ignition. Manual reset after lockout requires removing power from the control for more than 1 second or removing the thermostat call for heat for more than 1 second but no more than 20 seconds. 24 volt thermostat connections (P2) and heating component connections (J1) are made through separate jackplugs. See table 2 for thermostat terminations and table 3 for heating component terminations.

**TABLE 1**

LED	STATUS
Slow Flash	Normal operation. No call for heat.
Fast Flash	Normal operation. Call for heat.
Steady Off	Internal Control Fault, No Power To Board or Gas Valve Relay Fault
Steady On	Control Internal Failure.
2 Flashes	Lockout. Failed to detect or sustain flame.
3 Flashes	Rollout switch open / Prove switch open or closed.
4 Flashes	Primary High Limit switch open.
5 Flashes	Flame sensed but gas valve not open.

**TABLE 2**

P2 TERMINAL DESIGNATIONS	
Pin #	Function
1	R 24 Volts to thermostat
2	W1 Heat Demand
3	Y Cool Demand
4	C Common
5	G Indoor Blower
6	BL OUT Indoor Blower Relay
7	W2 Second Stage Heat

**TABLE 3**

J1 TERMINAL DESIGNATIONS	
Pin #	Function
1	Limit Switch Out
2	Rollout Switch / Prove Switch Out
3	Gas Valve Common
4	Gas Valve Out
5	Rollout Switch / Prove Switch In
6	Limit Switch In

Flame rectification sensing is used on all ZGB units. Loss of flame during a heating cycle is indicated by an absence of flame signal (0 microamps). If this happens, the control will immediately restart the ignition sequence and then lock out if ignition is not gained after the third trial. See System Service Checks section for flame current measurement.

The control shuts off gas flow immediately in the event of a power failure. Upon restoration of gas and power, the control will restart the ignition sequence and continue until flame is established or system locks out for one hour.

### Operation

On a heating demand, the ignition control checks for a closed limit switch and open (to prove switch is not failed closed prior to start-up) combustion air prove switch. Once this check is complete and conditions are correct, the ignition control then allows 30 seconds for the combustion air inducer to vent exhaust gases from the burners. When the combustion air inducer is purging the exhaust gases, the combustion air prove switch closes proving that the combustion air inducer is operating before allowing the ignition

control to energize. When the combustion air prove switch is closed and the delay is over, the ignition control activates the gas valve, the spark electrode and the flame sensing electrode. Once the gas valve is energized the non-adjustable 40 second indoor blower delay period begins. Sparking stops immediately after flame is sensed or at the end of the 8 second trial for ignition.

The control then proceeds to “steady state” mode where all inputs are monitored to ensure the limit switch, rollout switch and prove switch are closed as well as flame is present. When the heat call is satisfied and the gas valve is de-energized, a combustion air inducer post purge period of 5 seconds begins along with a 120 second blower off delay.

### **10-Power Exhaust Transformer T10 (J volt)**

Transformer T10 is a field-installed 600/230V transformer which provides power to the 208/230V power exhaust fan in 575V applications.

### **B-Cooling Components**

All units use a cooling circuit consisting of compressor, condenser coil and evaporator coil. See figure 5. One draw-through type condenser fan is used in ZGB units. Units are equipped with belt-drive blowers which draw air across the evaporator during unit operation.

Cooling may be supplemented by a factory- or field-installed economizer. The evaporator coil is slab type and

uses a fixed orifice refrigerant metering device. Each evaporator is also equipped with enhanced fins and rifled tubing. In all units each compressor is protected by a high pressure switch (S4) on the discharge line. See figure 5.

### **1-Compressor B1**

#### **⚠ IMPORTANT**

**The Clean Air Act of 1990 bans the intentional venting of refrigerant (CFC's and HCFC's) as of July 1, 1992. Approved methods of recovery, recycling or reclaiming must be followed. Fines and/or incarceration may be levied for non-compliance.**

All units use one scroll compressor. See “SPECIFICATIONS” and “ELECTRICAL DATA” (table of contents) or compressor nameplate for compressor specifications.

#### **⚠ WARNING**

**Electrical shock hazard. Compressor must be grounded. Do not operate without protective cover over terminals. Disconnect power before removing protective cover. Discharge capacitors before servicing unit. Failure to follow these precautions could cause electrical shock resulting in injury or death.**

The compressor is energized by a compressor contactor.

*NOTE-Refer to the wiring diagram section for specific unit operation.*

## ZGB PLUMBING

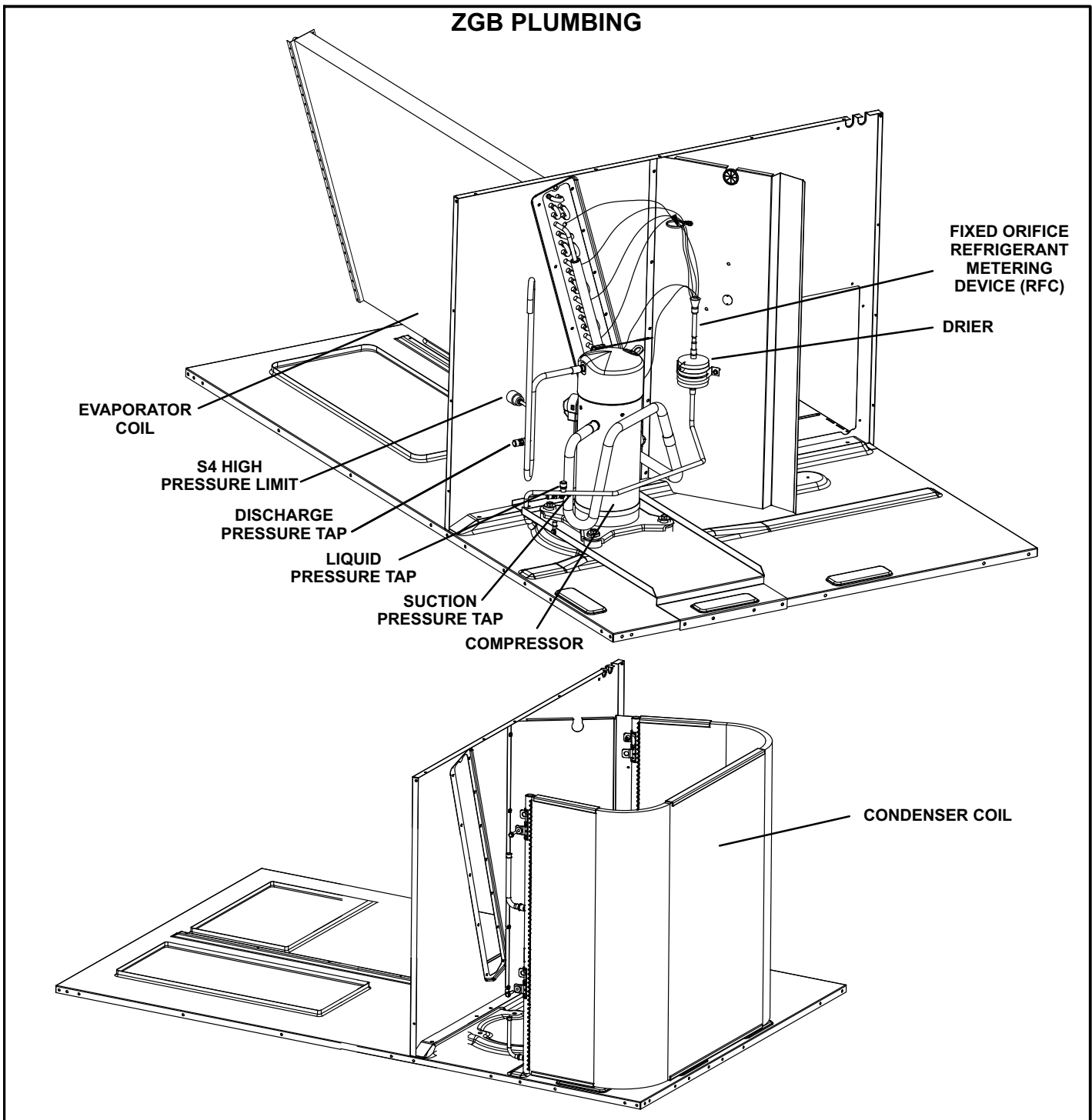

FIGURE 5

If Interlink compressor replacement is necessary, call 1-800-453-6669.

### **! IMPORTANT**

Some scroll compressors have an internal vacuum protector that will unload scrolls when suction pressure goes below 20 psig. A hissing sound will be heard when the compressor is running unloaded. Protector will reset when low pressure in system rises above 40 psig. **DO NOT REPLACE COMPRESSOR.**

### **2-High Pressure Switch S4**

The high pressure switch is an automatic reset SPST N.C. switch which opens on a pressure rise.

S4 is located in the compressor discharge line and wired in series with the compressor contactor coil.

When discharge pressure rises to  $640 \pm 10$  psig ( $4412 \pm 69$  kPa) (indicating a problem in the system) the switch opens and the respective compressor is de-energized (the economizer can continue to operate).



When discharge pressure drops to  $475 \pm 20$  ( $3275 \pm 138$  kPa) psig, the switch closes and the compressor is energized. The CMC1 board monitors the pressure switch when the compressor demand Y1 is active, allowing five strike lockout. The compressor is shut down indefinitely in this condition. A pressure switch may open and close again four times during a current demand cycle without causing a lockout condition by resetting the count at the end of the demand cycle (CMC1 Y1 input OFF). The five-strike lockout can only be reset by one of the following actions:

- Power cycle the controller
- Apply the TEST mode

### 3-Low Ambient Switches S11 (field-installed option)

The low ambient switch is an auto-reset SPST N.O. pressure switch which allows for mechanical cooling operation at low outdoor temperatures. The switch is located in the liquid line in the compressor section.

On P and Y volt units, S11 is wired in series with the common (black) lead to K10 outdoor fan motor.

On G and J volt units, S11 is wired in series with outdoor fan relay K10 coil and when opened breaks 24 volts to the coil, de-energizing outdoor fan B4.

When liquid pressure rises to  $450 \pm 10$  psig ( $3102 \pm 69$  kPa), the switch closes and the condenser fan is energized. When discharge pressure in drops to  $240 \pm 10$  psig ( $1655 \pm 69$  kPa), the switch opens and the condenser fan is de-energized. This intermittent fan operation results in higher evaporating temperature allowing the system to operate without icing the evaporator coil and losing capacity.

### 4-Compressor Low Discharge Temperature Limit S3 (field-supplied option)

S3 is a thermostat which opens on temperature drop. It is wired in line with the 24VAC compressor contactor.

### 5-Compressor High Temperature Limit S5

The compressor thermal protector is located on top of the compressor. S5 is wired in series with S4 high pressure limit. The protector opens at  $248^{\circ}\text{F} \pm 9^{\circ}\text{F}$  ( $120^{\circ}\text{C} \pm 5^{\circ}\text{C}$ ) and closes at  $169^{\circ}\text{F} \pm 18^{\circ}\text{F}$  ( $76^{\circ}\text{C} \pm 10^{\circ}\text{C}$ ).

### C-Blower Compartment

All units are equipped with belt drive blowers. See unit nameplate for blower type.

#### 1-Blower Wheels

ZGB-036, -048 and -060 belt drive units use 10" x 10" (254 mm x 254 mm) blower wheels. ZGB -074 units use 15 x 9 (381 x 229 mm) blower wheels.

## 2-Indoor Blower Motor B3

Belt drive units use single or three phase motors (same as supply voltage). CFM adjustments are made by adjusting the motor pulley (sheave). Motors are equipped with sealed ball bearings. All motor specifications are listed in the Specifications (see table of contents) section in the front of this manual. Units may be equipped with motors manufactured by various manufacturers, therefore electrical FLA and LRA specifications will vary. See unit rating plate for information specific to your unit.

## ! IMPORTANT

**Three phase scroll compressors must be phased sequentially for correct compressor and blower rotation. Follow "COOLING START-UP" section of installation instructions to ensure proper compressor and blower operation.**

### A-Blower Operation

Initiate blower demand at thermostat according to instructions provided with thermostat. Unit will cycle on thermostat demand. The following steps apply to applications using a typical electro-mechanical thermostat.

- 1- Blower operation is manually set at the thermostat sub-base fan switch. With fan switch in **ON** position, blowers will operate continuously.
- 2- With fan switch in **AUTO** position, the blowers will cycle with demand. Blowers and entire unit will be off when system switch is in **OFF** position.

### B-Determining Unit CFM

**IMPORTANT** - ZGB074S4T blower (G thermostat) **CFM MUST BE ADJUSTED IN HIGH SPEED**. Disconnect factory-installed J350 low speed connector from P350. Connectors are located near the bottom of the control box. Connect J351 high speed connector to P350. Once blower CFM is set, J350 can be reconnected to operate the blower on low during ventilation only demands. See table 4.

**TABLE 4  
TWO-SPEED BLOWER OPERATION  
ZGB074S4T UNITS**

Thermostat	Blower Speed
G (P350/J350)*	Low
G (P350/J351)	High
W1	High
W2	High
Y1	Low
Y2	High

\*Factory-installed jack/plug connection.

- 1- The following measurements must be made with air filters in place and no cooling demand.
- 2- With all access panels in place, measure static pressure external to unit (from supply to return). Blower performance data is based on static pressure readings taken in locations shown in figure 6.

*Note - Static pressure readings can vary if not taken where shown.*

- 3- Referring to the blower tables starting on Page 6, use static pressure and RPM readings to determine unit CFM. Use air resistance table when installing units with any of the options or accessories listed.

- 4- The blower RPM can be adjusted at the motor pulley. Loosen Allen screw and turn adjustable pulley clockwise to increase CFM. Turn counterclockwise to decrease CFM. See figure 7. Do not exceed minimum and maximum number of pulley turns as shown in table 5.

**5- ZGB074S4T Unit Only -**

If low speed during ventilation is desired, replace J351 connector with J350.

**TABLE 5  
MINIMUM AND MAXIMUM PULLEY ADJUSTMENT**

Belt	Min. Turns Open	Maxi. Turns Open
A Section	No minimum	5

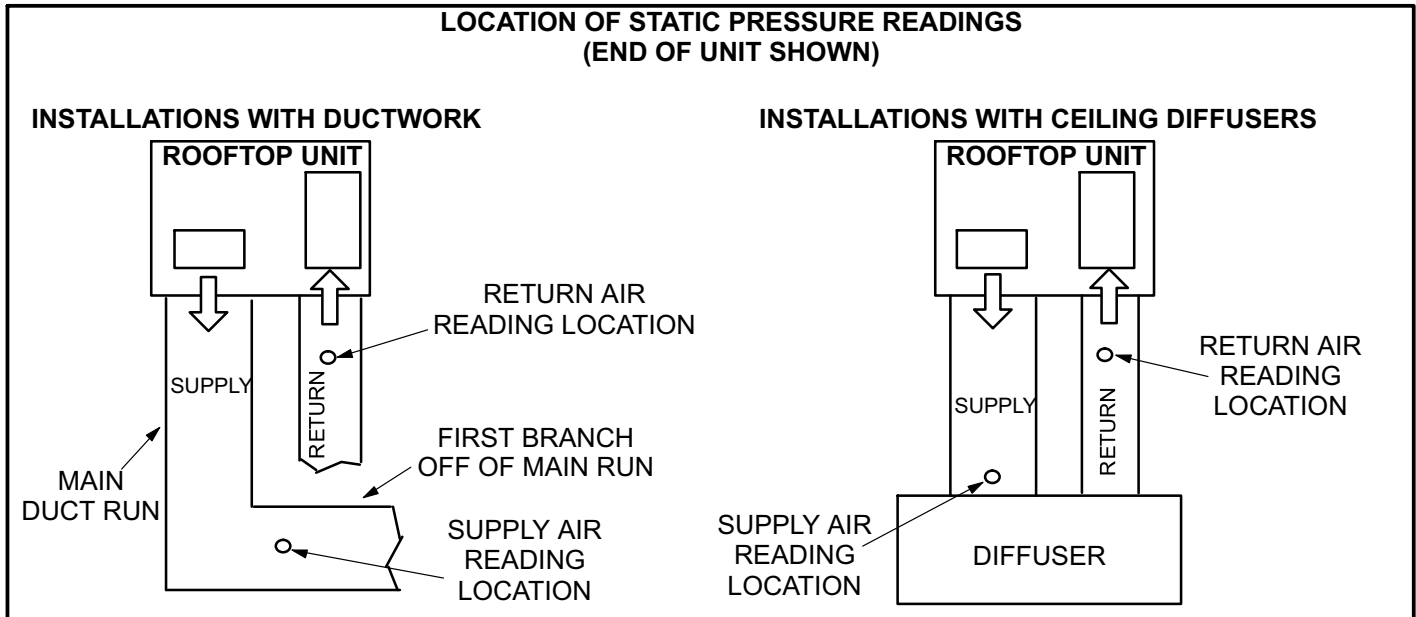

**FIGURE 6**

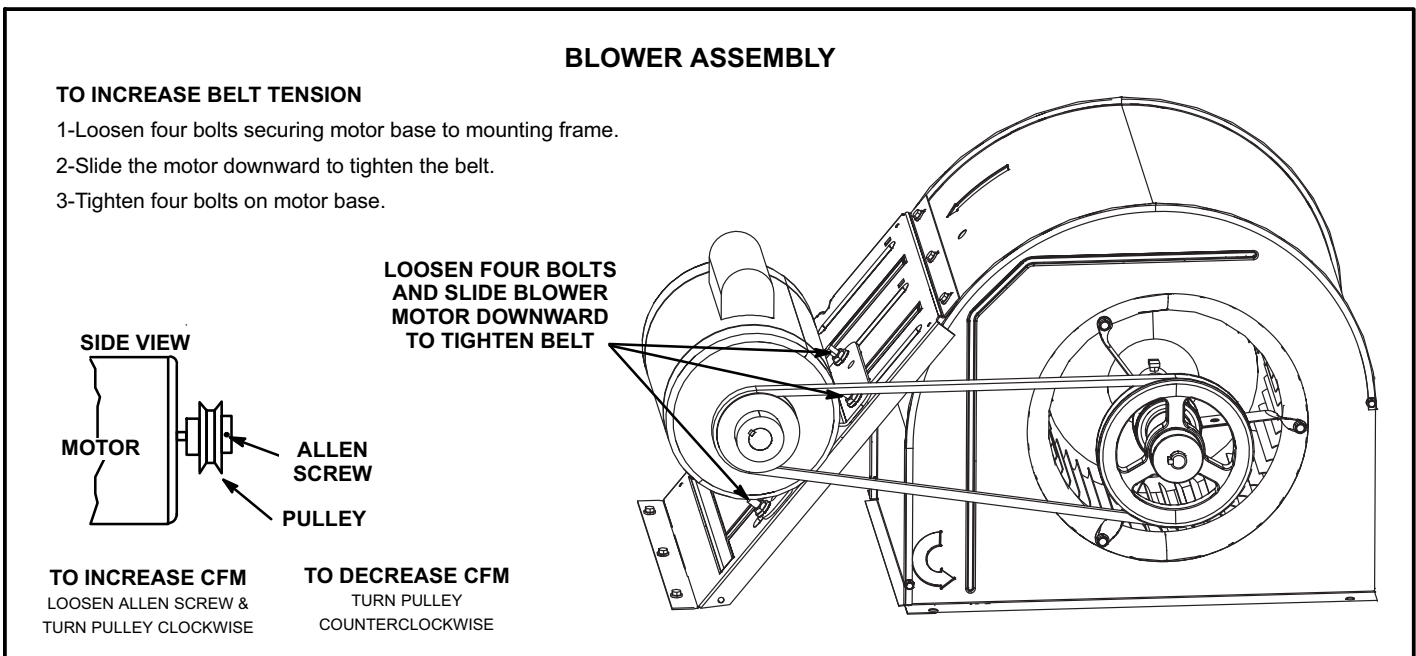

**FIGURE 7**

### C-Blower Belt Adjustment

Maximum life and wear can be obtained from belts only if proper pulley alignment and belt tension are maintained. Tension new belts after a 24-48 hour period of operation. This will allow belt to stretch and seat grooves. Make sure blower and motor pulley are aligned as shown in figure 8.

- 1- Loosen four bolts securing motor base to mounting frame. See figure 7.
- 2- *To increase belt tension -*  
Slide blower motor downward to tighten the belt. This increases the distance between the blower motor and the blower housing.
- 3- *To loosen belt tension -*  
Slide blower motor upward to loosen the belt. This decreases the distance between the blower motor and the blower housing.
- 4- Tighten four bolts securing motor base to the mounting frame.

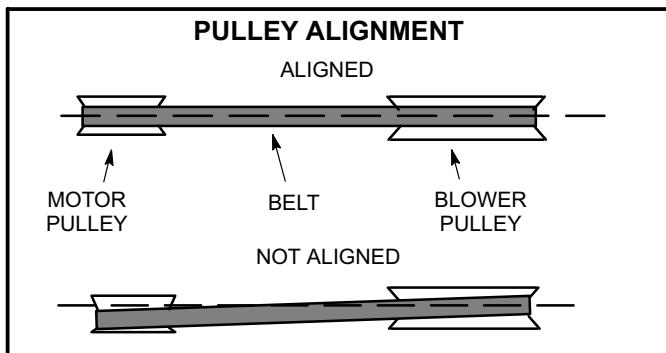

FIGURE 8

### D-Check Belt Tension

Overtensioning belts shortens belt and bearing life. Check belt tension as follows:

- 1- Measure span length X. See figure 9.

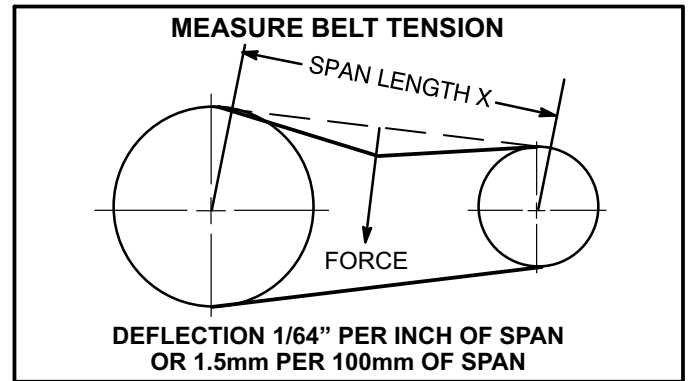

FIGURE 9

- 2- Apply perpendicular force to center of span (X) with enough pressure to deflect belt 1/64" for every inch of span length or 1.5mm per 100mm of span length.

Example: Deflection distance of a 40" span would be 40/64" or 5/8".

Example: Deflection distance of a 400mm span would be 6mm.

- 3- Measure belt deflection force. For a used belt, the deflection force should be 5 lbs. (35kPa). A new belt deflection force should be 7 lbs. (48kPa).

A force below these values indicates an undertensioned belt. A force above these values indicates an overtensioned belt.

### F-Field-Furnished Blower Drives

See blower data tables for field-furnished blower drives to determine BHP and RPM required. See table 6 for drive component manufacturers numbers.

TABLE 6  
DRIVE COMPONENT MANUFACTURER'S NUMBERS

Drive No.	DRIVE COMPONENT PART NUMBERS					
	Motor Pulley		Blower Pulley		Belts	
	Browning	OEM	Browning	OEM	Browning	OEM
Z01	1VP34 X 7/8	31K6901	AK54 X 5/8	100244-30	A40	100245-17
Z02	1VP34 X 7/8	31K6901	AK46 X 5/8	100244-31	A39	100245-16
Z03	1VP34 X 7/8	31K6901	AK41 X 5/8	100244-28	A39	100245-16
Z04	1VP34 X 7/8	31K6901	AK39 X 5/8	100244-32	A38	100245-15
Z05	1VP44 X 7/8	P-8-1488	AK49 X 5/8	100244-26	A41	100245-18
Z06	1VP50 X 7/8	53J1501	AK51 X 5/8	100244-29	A42	100245-19
ZAA02	1VP40 X 7/8	79J03	BK80H	100788-03	A53	100245-40
ZAA03	1VP40 X 7/8	79J03	AK59 X 1	31K68	A50	100245-29
ZAA04	1VP44 X 7/8	P-8-1488	AK59 X 1	31K68	AX51	13H01

# HEAT EXCHANGER ASSEMBLY

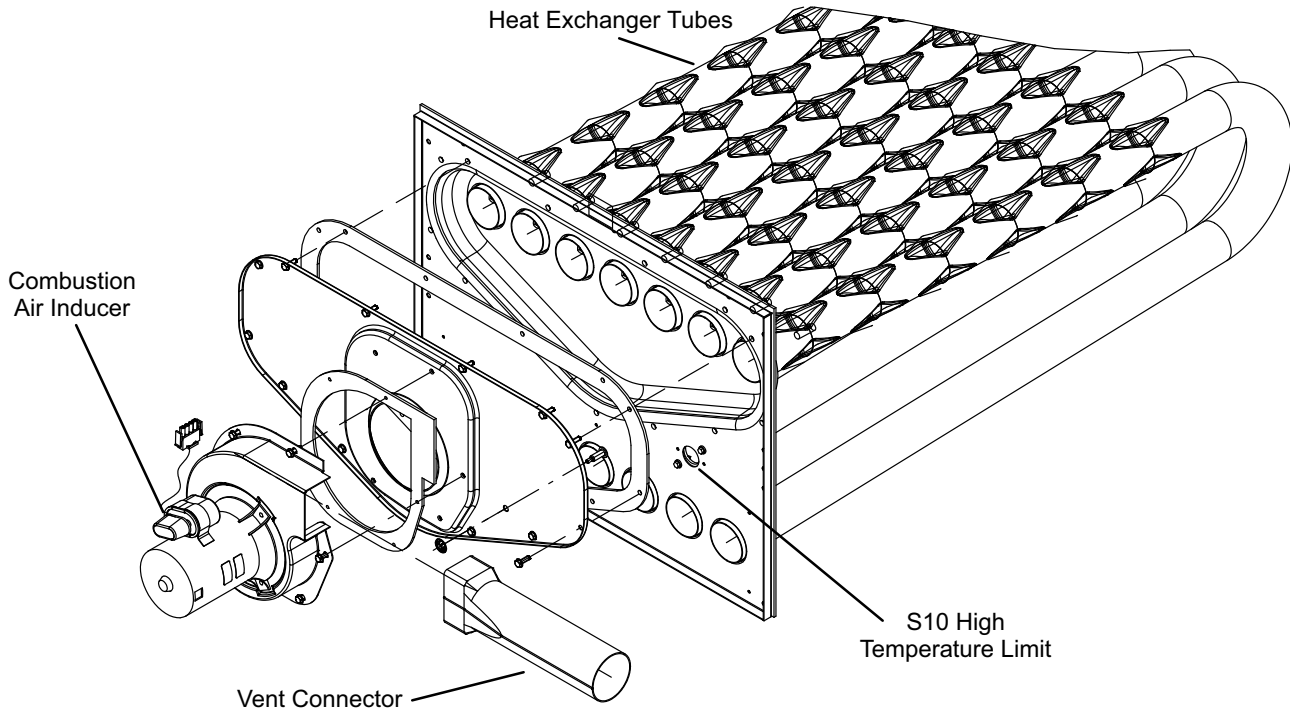

**FIGURE 10**

## D-GAS HEAT COMPONENTS

036, 048, 060, 074	Std gas heat; 1-stage	65Kbtuh input
036, 048, 060, 074	Med gas heat; 1-stage	108Kbtuh input
036, 048, 060, 074	Med gas heat; 2-stage	81/108Kbtu input
048, 060, 074	High gas heat; 1-stage	150Kbtu input
048, 060, 074	High gas heat; 2-stage	113/150Kbtu input

See Gas Heat Specifications on Page 5 for more detail.

### 1-Heat Exchanger Figure 10

The ZGB units use aluminized steel inshot burners with tubular aluminized steel heat exchangers and redundant gas valve. Burners in all units use a burner venturi to mix gas and air for proper combustion. Combustion takes place at each tube entrance. As hot combustion gases are drawn upward through each tube by the combustion air inducer, exhaust gases are drawn out the top and fresh air/gas mixture is drawn in at the bottom. Heat is transferred to the air stream from all surfaces of the heat exchanger tubes. The supply air blower forces air across the tubes to extract the heat of combustion. The shape of the tubes ensures maximum heat exchange.

The gas valves on two stage units accomplish staging by allowing more or less gas to the burners as called for by heating demand.

Low NOx models are available that meet the California Air Quality Management NOx requirement of 40 nanogram/joule. Stainless steel burner inserts are used to control flame temperatures to meet this emission level. See figure NO TAG.

### 2-Burner Box Assembly Figure 11

The burner assembly consists of a spark electrode, flame sensing electrode and gas valve. Ignition board A3 controls all functions of the assembly.

#### **Burners**

All units use inshot burners. Burners are factory-set and do not require adjustment. A peep hole with cover is furnished in the heating access panel for flame viewing. Always operate the unit with the access panel in place.

Burners can be removed as a one piece assembly for service. **Do not** try to separate.

#### **Orifice**

Each burner uses an orifice which is matched to the burner input. The orifice is threaded into the burner manifold. The burner is supported by the orifice and will easily slide off for service once the mounting screws are removed from the burners.

*NOTE-Do not use thread sealing compound on the orifices. Using thread sealing compound may plug the orifices.*

Each orifice and burner are sized specifically to the unit. Refer to Product Zone at [www.davenet.com](http://www.davenet.com) for correct sizing information.

### 3-Primary High Temperature Limit S10

S10 is a SPST N.C. high temperature primary limit for gas heat in all units. S10 is located on the vestibule panel. See figure 10.

Primary limit S10 is wired to the ignition control A3. Its N.C. contacts open to de-energize the ignition control when excessive temperature is reached in the blower compartment. If the limit trips the blower relay coil K3 will be energized by ignition control A3. Limit setpoints are factory set and cannot be adjusted. See [www.davenet.com](http://www.davenet.com) for setpoint and replacement.

### 4-Flame Rollout Limit Switch S47

Flame rollout limit switch S47 is a SPST N.C. high temperature limit located just above the burner air intake opening in the burner enclosures (see figure NO TAG ). S47 is wired to the ignition control A3. When S47 senses flame rollout (indicating a blockage in the combustion air passages), the flame rollout limit trips, and the ignition control immediately closes the gas valve.

Limit S47 is factory preset to open at  $350^{\circ}\text{F} \pm 14^{\circ}\text{F}$  on a temperature rise on all units. All flame rollout limits are manual reset.

### 5-Combustion Air Prove Switch S18

Prove switch S18 is a SPST N.O. switch located to the right of the induced draft assembly. See figure 11. S18 monitors combustion air inducer operation. Switch S18 is wired to the ignition control A3. The switch closes at *negative*  $0.25''\text{W.C.} \pm 0.05''$  ( $62.2\text{ Pa} \pm 12.4\text{ Pa}$ ) on pressure fall. This negative pressure fall and switch actuation allows the ignition sequence to continue (proves, by closing, that the combustion air inducer is operating before allowing the gas valve to open.) The combustion air prove switch is factory set and not adjustable.

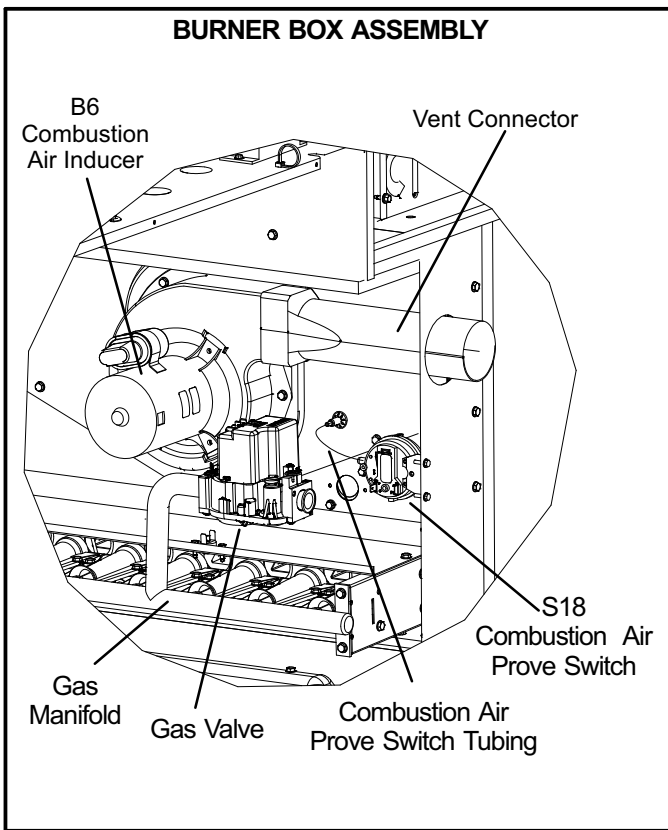

FIGURE 11

### 6-Combustion Air Inducer B6

Combustion air inducers provide air to the corresponding burners while clearing the combustion chamber of exhaust gases. The inducer begins operating immediately upon receiving a thermostat demand and is de-energized when thermostat demand is satisfied.

The inducer uses a 208/230V single-phase PSC motor and a 5.24 in. x .96in. blower wheel. All motors operate at 3300RPM and are equipped with auto-reset overload protection. Inducers are supplied by various manufacturers. Ratings may vary by manufacturer. Specific inducer electrical ratings can be found on the unit rating plate.

On a heating demand (W1), the ignition control A3 initiates the heating cycle. A3 then allows 30 seconds for the combustion air inducer to vent exhaust gases from the burners. When the combustion air inducer is purging the exhaust gases, the combustion air prove switch closes, proving that the combustion air inducer is operating before allowing the ignition sequence to continue. When the combustion air prove switch is closed and the delay is over, the ignition control activates the first stage operator of the gas valve (low fire), the spark and the flame sensing electrode. Sparking stops immediately after flame is sensed or at the end of the eight second trial for ignition.

On two-stage natural gas units, the inducer speed depends on the thermostat. A W2 thermostat demand will start the inducer in high speed for second-stage heat and a W1 thermostat demand will start the inducer in low speed for first-stage heat.

All combustion air inducer motors are sealed and cannot be oiled. The inducer cannot be adjusted but can be removed from the vestibule to clean the wheel.

### 7-Combustion Air Motor Capacitor C3

The combustion air inducer motors in all ZGB units require run capacitors. Capacitor C3 is connected to combustion air inducer B6. Ratings will be on side of capacitor or combustion air motor nameplate.

### 8-Gas Valves GV1

Units are equipped with a single or two stage gas valve. On a call for first-stage heat (low fire), the valve is energized by the ignition control simultaneously with the spark electrode. On a call for second stage heat (high fire), the second stage operator is energized directly from A3. A manual shut-off switch is provided on the valve for shut-off. Manual shut-off switch immediately closes both stages without delay. On both valves first stage (low fire) is quick opening (on and off in less than 3 seconds).

The gas valve is adjustable for both low fire and high fire. Figures 14 and 15 show gas valve components. Table 7 shows factory gas valve regulation pressures.

TABLE 7

Operating Manifold Pressure			
Natural		L.P.	
Low	High	Low	High
1.7 ± 0.3" W.C.	3.5 ± 0.3" W.C.	5.1" ± 0.3" W.C	10.5" ± 0.5" W.C.

### 9-Spark Electrode (Ignitor) Figure 12

An electrode assembly is used for ignition spark. The electrode is mounted through holes under the burner located farthest to the right. The electrode tip protrudes into the flame envelope of the adjacent burner. The electrode assembly is fastened to burner supports and can be removed for service without removing any part of the burners.

During ignition, spark travels through the spark electrode (figure 12) and ignites the right burner. Flame travels from burner to burner until all are lit.

The spark electrode is connected to the ignition control by a Teflon coated copper wire. The wire uses 1/4" (6.35 mm) female quick connects on both ends of the wire.

*NOTE - If electrode wire must be replaced, wire and suppression must be same type cable. See www.dav-enet for replacement.*

The spark electrode assembly can be removed for inspection by removing the screw securing the electrode assembly and sliding it out of unit.

For proper unit operation, electrodes must be positioned and gapped correctly.

Spark gap may be checked with appropriately sized twist drills or feeler gauges. Disconnect power to the unit and remove electrode assembly. The gap should be between 0.125" ± 0.015" (3.2 mm ± .4 mm). See figure 12.



## **⚠️ IMPORTANT**

In order to maximize spark energy to electrode, high voltage wire should touch unit cabinet as little as possible.

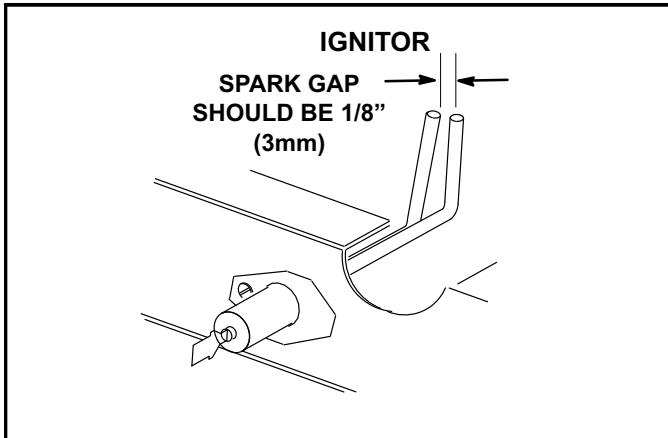

FIGURE 12

### 10-Flame Sensor Figure 13

A flame sensor is located under the burner located farthest to the left. The sensor is mounted through a hole in the burner support and the tip protrudes into the flame envelope of the left most burner. The sensor assembly is fastened to burner supports and can be removed for service without removing any part of the burners.

When flame is sensed by the flame sensor (indicated by microamp signal through the flame), sparking stops immediately or after the eight-second trial for ignition. During operation, flame is sensed by current passed along the ground electrode (located on the spark electrode), through the flame and into the sensing electrode. The ignition control allows the gas valve to stay open as long as a flame signal (current passed through the flame) is sensed.

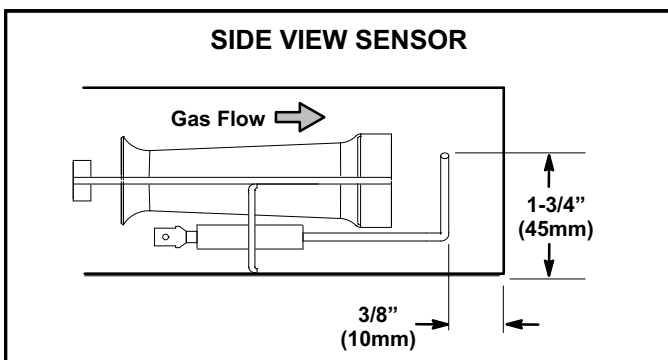

FIGURE 13

## II-PLACEMENT AND INSTALLATION

Make sure the unit is installed in accordance with the installation instructions and all applicable codes. See accessories section for conditions requiring use of the optional roof mounting frame (Z1CURB).

## III-START UP - OPERATION

### A-Preliminary and Seasonal Checks

- 1- Make sure the unit is installed in accordance with the installation instructions and applicable codes.
- 2- Inspect all electrical wiring, both field and factory installed for loose connections. Tighten as required. Refer to unit diagram located on inside of control panel.
- 3- Check to ensure that refrigerant lines are in good condition and do not rub against the cabinet or other refrigerant lines.
- 4- Check voltage at the disconnect switch. Voltage must be within the range listed on the nameplate. If not, consult the power company and have the voltage corrected before starting the unit.
- 5- Recheck voltage and amp draw with unit running. If voltage is not within range listed on unit nameplate, stop unit and consult power company. Refer to unit nameplate for maximum rated load amps.
- 6- Inspect and adjust blower belt (see section on Blower Compartment - Blower Belt Adjustment).

### B-Heating Start up

#### FOR YOUR SAFETY READ BEFORE LIGHTING

## **⚠️ WARNING**



Electric shock hazard. Can cause injury or death. Do not use this unit if any part has been under water. Immediately call a qualified service technician to inspect the unit and to replace any part of the control system and any gas control which has been under water.

## **⚠️ WARNING**



Danger of explosion. Can cause injury or product or property damage. If overheating occurs or if gas supply fails to shut off, shut off the manual gas valve to the appliance before shutting off electrical supply.

## **⚠️ WARNING**



Electric shock hazard. Can cause injury or death. Before attempting to perform any service or maintenance, turn the electrical power to unit OFF at disconnect switch(es). Unit may have multiple power supplies.

## **⚠️ WARNING**

### SMOKE POTENTIAL

The heat exchanger in this unit could be a source of smoke on initial firing. Take precautions with respect to building occupants and property. Vent initial supply air outside when possible.

BEFORE LIGHTING smell all around the appliance area for gas. Be sure to smell next to the floor because some gas is heavier than air and will settle on the floor.

The gas valve is equipped with an ON/OFF switch. Use only your hand to push the switch. Never use tools. If the the switch will not move do not try to repair it. Call a qualified service technician. Force or attempted repair may result in a fire or explosion.

## ⚠ WARNING



**Danger of explosion. Can cause injury or death. Do not attempt to light manually. Unit has a direct spark ignition system.**

This unit is equipped with an automatic spark ignition system. There is no pilot. In case of a safety shutdown, move thermostat switch to **OFF** and return the thermostat switch to **HEAT** to reset ignition control.

### A-Placing Unit In Operation

## ⚠ WARNING



**Danger of explosion and fire. Can cause injury or product or property damage. You must follow these instructions exactly.**

### Gas Valve Operation (figure 14 and 15)

- 1- Set thermostat to lowest setting.
- 2- Turn off all electrical power to appliance.
- 3- This appliance is equipped with an ignition device which automatically lights the burner. Do **not** try to light the burner by hand.
- 4- Open or remove the heat section access panel.
- 5- Move gas valve switch to **OFF**. See figure 14 or 15.
- 6- Wait five (5) minutes to clear out any gas. If you then smell gas, **STOP!** Immediately call your gas supplier from a neighbor's phone. Follow the gas supplier's instructions. If you do not smell gas, go to the next step.
- 7- Move gas valve switch to **ON**. See figure 14 or 15.
- 8- Close or replace the heat section access panel.
- 9- Turn on all electrical power to appliance.
- 10- Set thermostat to desired setting.

*NOTE - When unit is initially started, steps 1 through 9 may need to be repeated to purge air from gas line.*

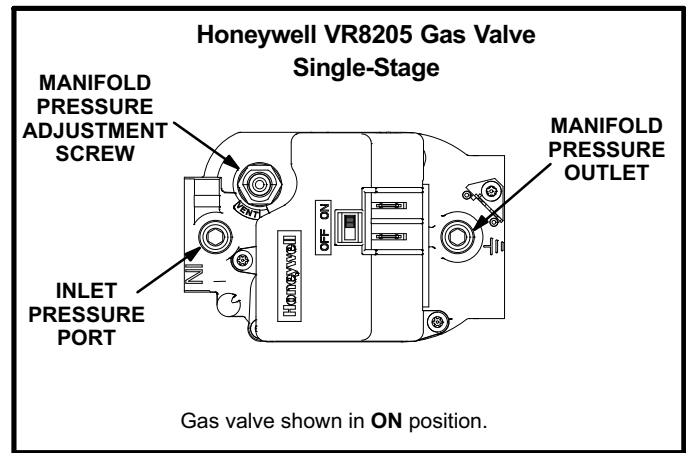

FIGURE 14

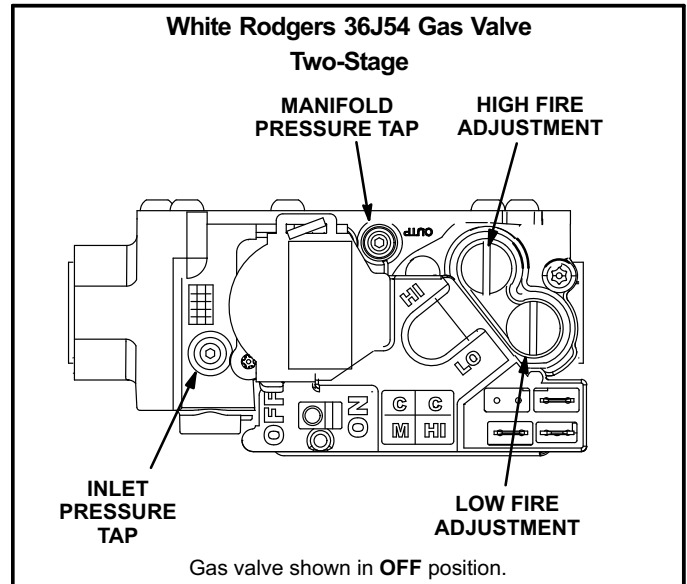

FIGURE 15

- 11- The ignition sequence will start.
- 12- If the furnace does not light the first time (gas line not fully purged), it will attempt up to two more ignitions before locking out.
- 13- If lockout occurs, repeat steps 1 through 10.
- 14- If the appliance will not operate, follow the instructions "Turning Off Gas to Appliance" and call your service technician or gas supplier.

## C-Cooling Start-Up

### A-Operation

- 1- Initiate first and second stage cooling demands according to instructions provided with thermostat.

*Note - ZGB074 units are equipped with two-stage compressors.*

#### 2- No Economizer Installed in Unit -

A first-stage cooling demand (Y1) will energize compressor 1 and the condenser fan. An increased cooling demand (Y2) will not change operation.

#### Units Equipped With Economizer -

When outdoor air is acceptable, a first-stage cooling demand (Y1) will energize the economizer. An increased cooling demand (Y2) will energize compressor 1 and the condenser fan. When outdoor air is not acceptable unit will operate as though no economizer is installed.

#### 074 Units With No Economizer Installed

A first-stage cooling demand (Y1) will energize compressor on low speed (67% capacity) and the condenser fan. An increased cooling demand (Y2) will energize the compressor to high speed (full capacity)

#### 074 Units Equipped With Economizer -

When outdoor air is acceptable, a first-stage cooling demand (Y1) will energize the economizer. An increased cooling demand (Y2) will energize compressor on low speed (67% capacity) and the condenser fan. When outdoor air is not acceptable unit will operate as though no economizer is installed.

- 3- Units contain one refrigerant circuit or stage.
- 4- Unit is charged with R-410A refrigerant. See unit rating plate for correct amount of charge.
- 5- Refer to Refrigerant Charge and Check section for proper method to check refrigerant charge.

### B-Three Phase Scroll Compressor Voltage Phasing

Three phase scroll compressors must be phased sequentially to ensure correct compressor and blower rotation and operation. Compressor and blower are wired in phase at the factory. Power wires are color-coded as follows: line 1-red, line 2-yellow, line 3-blue.

- 1- Observe suction and discharge pressures and blower rotation on unit start-up.
- 2- Suction pressure must drop, discharge pressure must rise and blower rotation must match rotation marking.

If pressure differential is not observed or blower rotation is not correct:

- 3- Disconnect all remote electrical power supplies.
- 4- Reverse any two field-installed wires connected to the line side of K1 contactor. Do not reverse wires at blower contactor.

- 5- Make sure the connections are tight.

Discharge and suction pressures should operate at their normal start-up ranges.

### D-Safety or Emergency Shutdown

Turn off power to unit. Close manual and main gas valves.

### IV-CHARGING

**WARNING-Do not exceed nameplate charge under any condition.**

This unit is factory charged and should require no further adjustment. If the system requires additional refrigerant, reclaim the charge, evacuate the system, and add required nameplate charge.

*NOTE - System charging is not recommended below 60°F (15°C). In temperatures below 60°F (15°C), the charge **must** be weighed into the system.*

If weighing facilities are not available, or to check the charge, use the following procedure:

**IMPORTANT - Charge unit in standard cooling mode high stage only.**

- 1- Make sure outdoor coil is clean. Attach gauge manifolds and operate unit at full CFM in cooling mode with economizer disabled until system stabilizes (approximately five minutes). Make sure all outdoor air dampers are closed.
- 2- Compare the normal operating pressures (see tables 8 - 11) to the pressures obtained from the gauges. Check unit components if there are significant differences.
- 3- Measure the outdoor ambient temperature and the suction pressure. Refer to the appropriate circuit charging curve to determine a target liquid temperature.

*Note - Pressures are listed for sea level applications.*

- 4- Use the same thermometer to accurately measure the liquid temperature (in the outdoor section).
  - If measured liquid temperature is higher than the target liquid temperature, add refrigerant to the system.
  - If measured liquid temperature is lower than the target liquid temperature, recover some refrigerant from the system.

- 5- Add or remove charge in increments. Allow the system to stabilize each time refrigerant is added or removed.
- 6- Continue the process until measured liquid temperature agrees with the target liquid temperature. Do not go below the target liquid temperature when adjusting charge. Note that suction pressure can change as charge is adjusted.
- 7- Example ZGB036: At 95°F outdoor ambient and a measured suction pressure of 130psig, the target liquid temperature is 102°F. For a measured liquid temperature of 106°F, add charge in increments until measured liquid temperature agrees with the target liquid temperature.

**TABLE 8  
ZGB036 NORMAL OPERATING PRESSURES - ALL-ALUMINUM COIL**

Outdoor Coil Entering Air Temperature											
65 °F		75 °F		85 °F		95 °F		105 °F		115 °F	
Suct (psig)	Disc (psig)	Suct (psig)	Disc (psig)	Suct (psig)	Disc (psig)	Suct (psig)	Disc (psig)	Suct (psig)	Disc (psig)	Suct (psig)	Disc (psig)
116	231	119	269	122	311	126	356	129	405	132	458
123	234	127	271	130	313	133	359	137	408	140	462
140	245	144	280	147	321	151	368	155	417	159	471
156	261	160	297	167	338	170	383	173	433	178	489

**TABLE 9  
ZGB048 NORMAL OPERATING PRESSURES - ALL-ALUMINUM COIL**

Outdoor Coil Entering Air Temperature											
65 °F		75 °F		85 °F		95 °F		105 °F		115 °F	
Suct (psig)	Disc (psig)	Suct (psig)	Disc (psig)	Suct (psig)	Disc (psig)	Suct (psig)	Disc (psig)	Suct (psig)	Disc (psig)	Suct (psig)	Disc (psig)
112	244	115	283	118	326	121	373	124	423	127	480
118	248	122	288	126	331	130	379	133	429	136	477
135	258	138	298	142	341	145	389	150	441	153	496
149	272	154	311	158	355	162	402	166	455	171	493

**TABLE 10  
ZGB060 NORMAL OPERATING PRESSURES - ALL-ALUMINUM COIL**

Outdoor Coil Entering Air Temperature											
65 °F		75 °F		85 °F		95 °F		105 °F		115 °F	
Suct (psig)	Disc (psig)	Suct (psig)	Disc (psig)	Suct (psig)	Disc (psig)	Suct (psig)	Disc (psig)	Suct (psig)	Disc (psig)	Suct (psig)	Disc (psig)
106	248	110	288	114	331	118	378	123	428	126	483
114	254	118	292	122	336	125	384	129	435	133	493
130	267	134	308	138	353	142	401	146	455	151	511
147	290	151	329	155	372	159	420	164	477	169	533

**TABLE 11  
ZGB074 NORMAL OPERATING PRESSURES - ALL-ALUMINUM COIL**

Outdoor Coil Entering Air Temperature											
65 °F		75 °F		85 °F		95 °F		105 °F		115 °F	
Suct (psig)	Disc (psig)	Suct (psig)	Disc (psig)	Suct (psig)	Disc (psig)	Suct (psig)	Disc (psig)	Suct (psig)	Disc (psig)	Suct (psig)	Disc (psig)
113	255	116	295	119	340	121	386	125	438	127	493
121	260	124	301	127	345	130	394	133	446	136	502
136	271	140	311	143	353	147	403	150	455	154	512
151	288	157	327	162	372	166	422	169	474	174	540

### ZGB036 CHARGING CURVE - ALL-ALUMINUM COIL

Outdoor Temperature (°F)

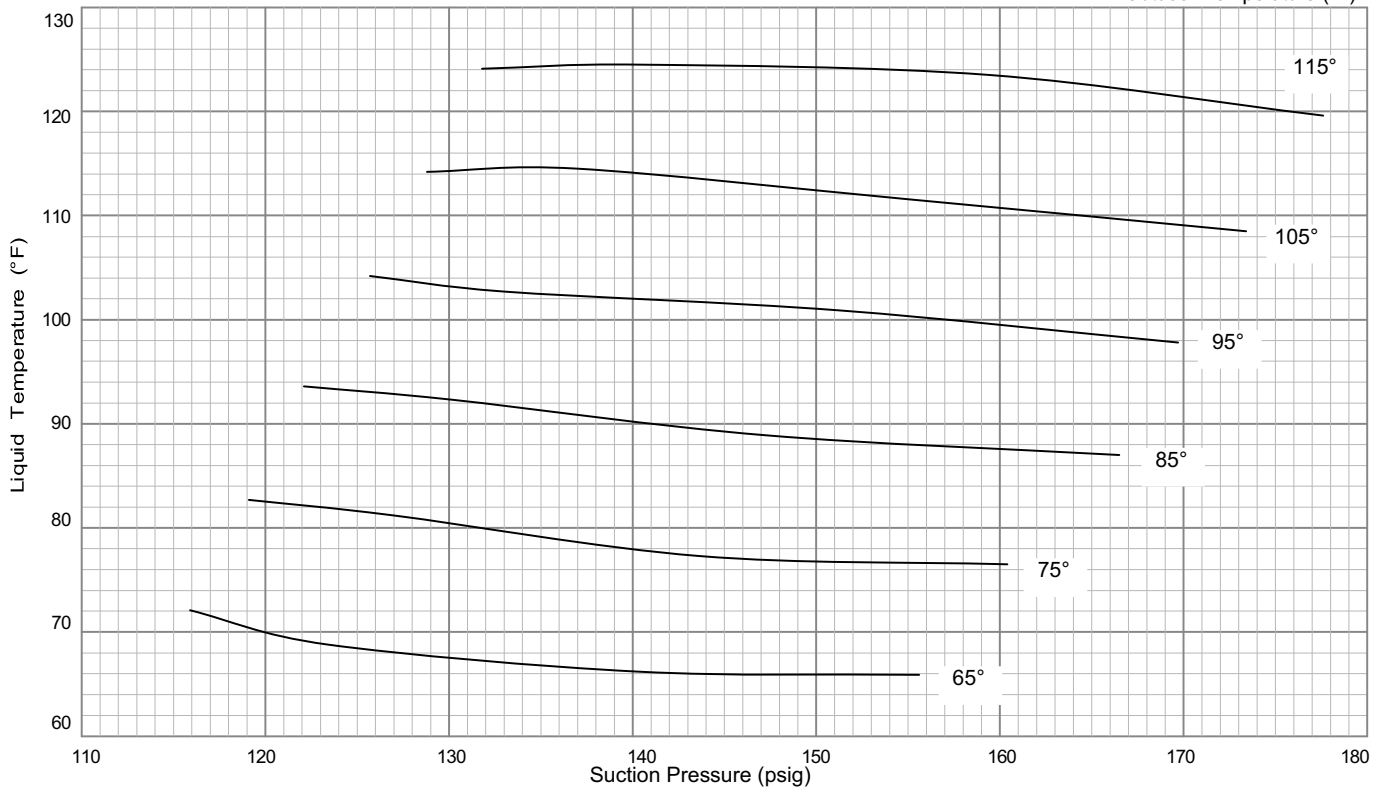

### ZGB048 CHARGING CURVE - ALL-ALUMINUM COIL

Outdoor Temperature (°F)

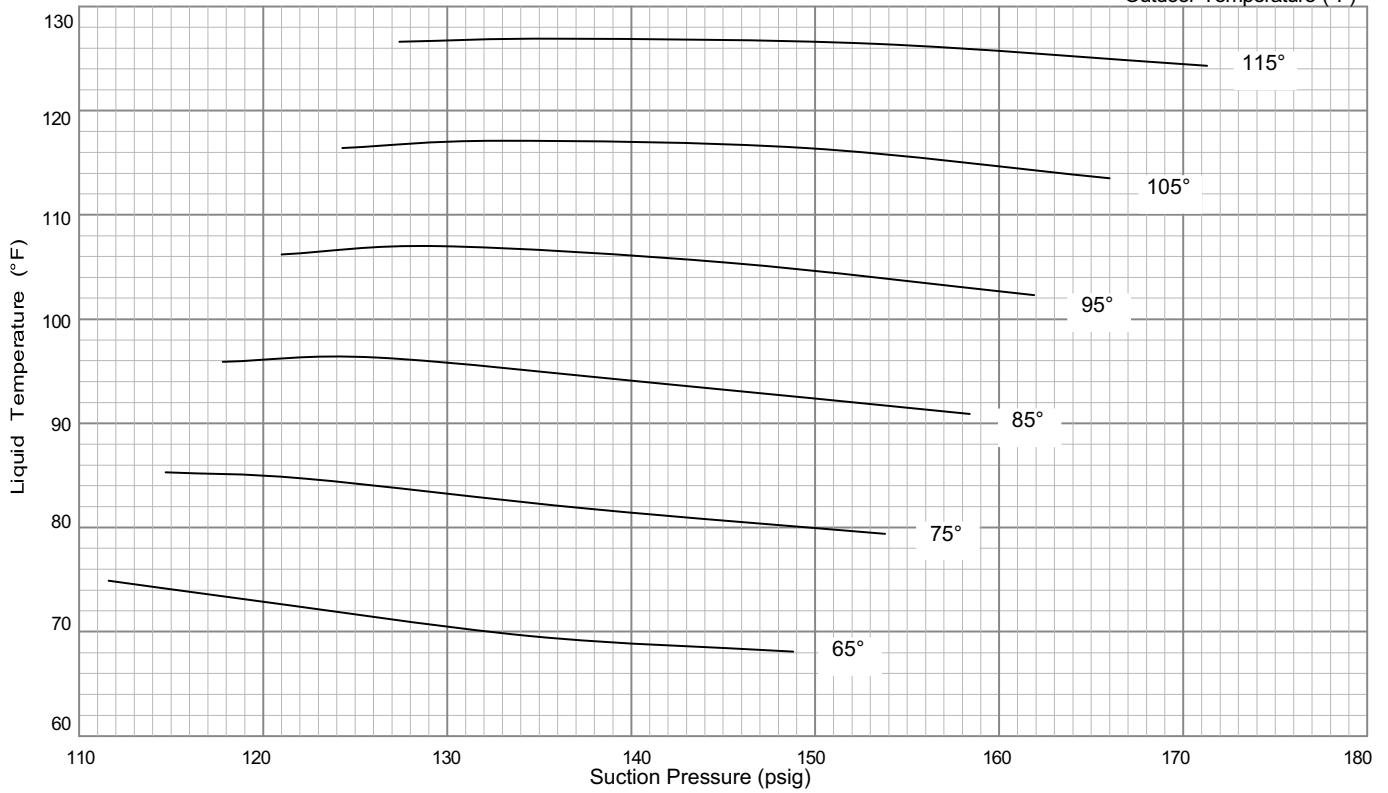

### ZGB060 CHARGING CURVE - ALL-ALUMINUM COIL

Outdoor Temperature (°F)

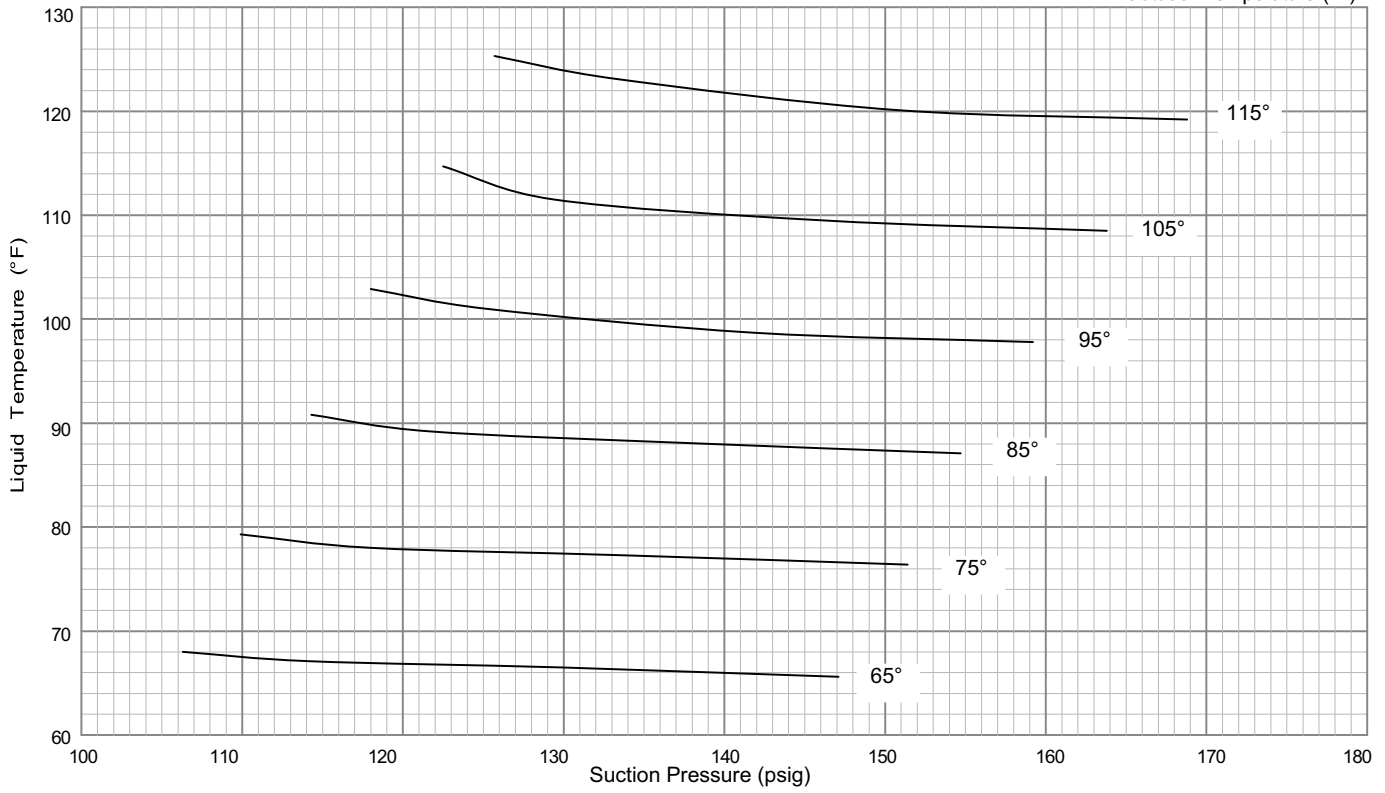

### ZGB074 CHARGING CURVE - ALL-ALUMINUM COIL

Outdoor Temperature (°F)

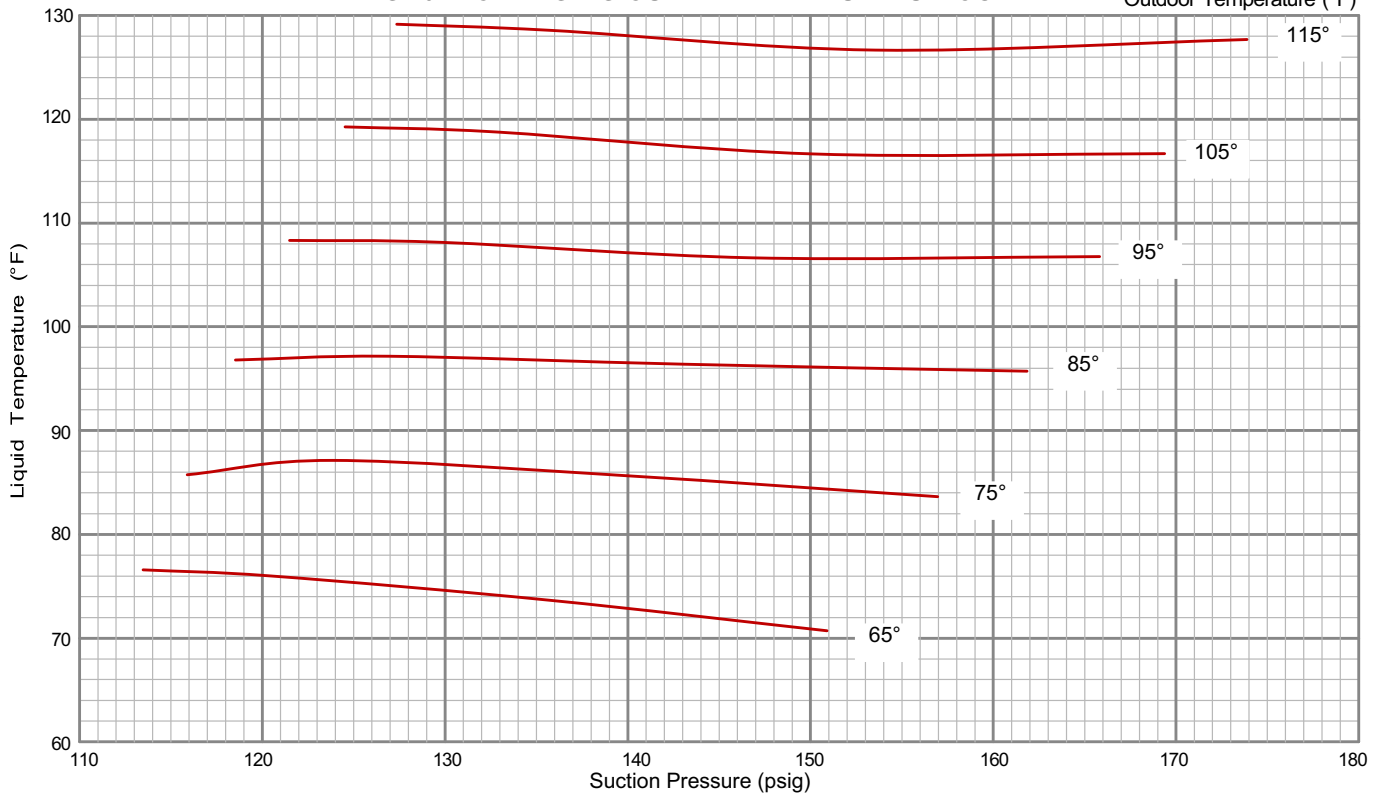

## V- SYSTEM SERVICE CHECKS

### A-Heating System Service Checks

All ZGB units are C.S.A. design certified without modification.

Before checking piping, check with gas company or authorities having jurisdiction for local code requirements. Refer to the ZGB Installation instruction for more information.

#### 1-Gas Piping

Gas supply piping must not allow more than 0.5"W.C. (124.3 Pa) drop in pressure between the gas meter and the unit. Supply gas pipe must not be smaller than the unit gas connection. Refer to installation instructions for details.

#### 2-Testing Gas Piping

*NOTE-In case emergency shutdown is required, turn off the main manual shut-off valve and disconnect the main power to the unit. These controls should be properly labeled by the installer.*

When pressure testing gas lines, the gas valve must be disconnected and isolated. **Gas valves can be damaged if subjected to more than 0.5 psig [14"W.C. (3481 Pa)].** See figure 16.

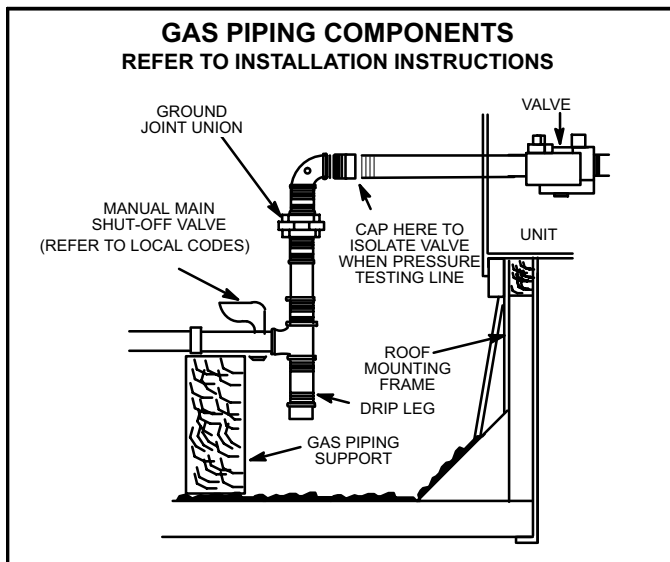

FIGURE 16

When checking piping connection for gas leaks, use the preferred means. Common kitchen detergents can cause harmful corrosion on various metals used in gas piping. The use of specialty Gas Leak Detector is strongly recommended. It is available as part number 31B2001. See CORP 8411-L10, for further details.

**Do not use matches, candles, flame or any other source of ignition to check for gas leaks.**

### 3-Testing Gas Supply Pressure

When testing gas supply pressure, connect test gauge to the inlet pressure tap located on unit gas valve GV1. Test supply gas pressure with unit firing at maximum rate (both stages energized). Make sure the reading falls within the range of the following values. Low pressure may result in erratic operation or "underfire." High pressure can result in permanent damage to the gas valve or "overfire." For natural gas units, operating pressure at the unit gas connection must be between 4.5"W.C. and 10.5"W.C. For L.P. gas units, operating pressure at the unit gas connection must be between 11"W.C. and 13.0"W.C.

On multiple unit installations, each unit should be checked separately while operating at maximum rate, beginning with the one closest to the supply gas main and progressing to the one furthest from the main. Multiple units should also be tested with and without the other units operating. Supply pressure must fall within the range listed in the previous paragraph.

#### 4-Check and Adjust Manifold Pressure

After line pressure has been checked and adjusted, check manifold pressure. Move test gauge to the outlet pressure tap located on unit gas valve GV1. See figure 14 or 15 for location of pressure tap on the gas valve.

The manifold pressure is factory set and should not require adjustment. See table 7. If manifold pressure is incorrect and no other source of improper manifold pressure can be found, the valve must be replaced. See figure 14 or 15 for location of gas valve (manifold pressure) adjustment screw.

All gas valves are factory regulated. The gas valve should completely and immediately cycle off in the event of gas or power failure. The manual shut-off switch can be used to immediately shut off gas supply.

### CAUTION

**For safety, connect a shut-off valve between the manometer and the gas tap to permit shut off of gas pressure to the manometer.**

#### Manifold Adjustment Procedure

- 1- Connect test gauge to the outlet pressure tap on the gas valve. Start the unit (call for second stage heat) and allow five minutes for the unit to reach steady state.
- 2- While waiting for the unit to stabilize, notice the flame. The flame should be stable without flashback and should not lift from the burner heads. Natural gas should burn basically blue with some clear streaks. L.P. gas should burn mostly blue with some clear yellow streaks.
- 3- After allowing the unit to stabilize for five minutes, record the manifold pressure and compare to the values given in table 7.



## 5-Proper Gas Flow

Furnace should operate at least 5 minutes before checking gas flow. Determine time in seconds for two revolutions of gas through the meter. (Two revolutions assures a more accurate time.) Divide by two and compare to time in table 12. Seconds in table 12 are based on a 1 cu.ft. dial and gas value of 1000 btu/ft<sup>3</sup> for natural and 2500 btu/ft<sup>3</sup> for LP. Adjust manifold pressure on gas valve to match time needed.

*NOTE - To obtain accurate reading, shut off all other gas appliances connected to meter.*

**TABLE 12**

GAS METER CLOCKING CHART				
Unit Input Rate (Btuh)	Seconds for One Revolution			
	Natural		LP	
	1 cu ft Dial	2 cu ft Dial	1 cu ft Dial	2 cu ft Dial
65,000	55	111	138	277
81,000	44	88	111	222
108,000	33	67	83	167
113,000	31	62	79	158
130,000	28	55	69	138
150,000	24	48	60	120
169,000	21	43	53	107
180,000	20	40	50	100
240,000	15	30	38	75
260,000	14	28	35	69
360,000	10	20	30	50
480,000	8	15	19	38
Natural-1000 btu/cu ft		LP-2500 btu/cu ft		

*Note: Table assumes standard temperature (60°F), pressure (30in.Hg.), and fuel heating values (Btuh/Ft.<sup>3</sup>). Apply pressure corrections in altitudes above 2000 ft.*

### **IMPORTANT**

**Disconnect heating demand as soon as an accurate reading has been obtained.**

## 6-Heat Exchanger

Visually inspect heat exchanger. If replacement is necessary refer to the instruction provided with the replacement kit.

## 7-Flame Sensing

Flame current is an electrical current which passes from the ignition control through the sensor electrode during unit operation. The current passes from the sensor through the flame to the ground electrode (located on the flame electrode) to complete a safety circuit. The electrodes should be located so the tips are at least 1/2" (12.7 mm) inside the flame envelope. Do not bend electrodes. To measure flame current, use the following procedure:

*NOTE-Electrodes are not field adjustable. Any alterations to the electrode may create a hazardous condition that can cause property or personal injury.*

- 1- Disconnect power to unit.
- 2- Remove lead from sensing electrode and install a 0-50DC microamp meter in series between the sensing electrode and the sensing lead.
- 3- Reconnect power and adjust thermostat for heating demand.
- 4- When flame is established, microamp reading should be 0.5 to 1.0. Do not bend electrodes.  
*Drop out signal is .09 or less.*
- 5- Disconnect power to unit before disconnecting meter. Make sure sensor wire is securely reconnected before reconnecting power to unit.

*NOTE-If the meter scale reads 0, the leads are reversed. Disconnect power and reconnect leads for proper polarity.*

## B-Cooling System Service Checks

ZGB units are factory charged and require no further adjustment; however, charge should be checked periodically. See section IV- CHARGING.

*NOTE-When unit is properly charged discharge and suction pressures should approximate those in tables 8 through 11.*

## VI-MAINTENANCE

The unit should be inspected once a year by a qualified service technician.

<b>⚠ WARNING</b>	
	<b>Electric shock hazard. Can cause injury or death. Before attempting to perform any service or maintenance, turn the electrical power to unit OFF at disconnect switch(es). Unit may have multiple power supplies.</b>

<b>⚠ CAUTION</b>	
<b>Label all wires prior to disconnection when servicing controls. Wiring errors can cause improper and dangerous operation. Verify proper operation after servicing.</b>	

### A-Filters

Units are equipped with temporary filters which must be replaced prior to building occupation. All units use 14 X 20 X 2" (352 X 508 X 51mm) filters. Refer to local codes or appropriate jurisdiction for approved filters. Filters should be checked monthly and replaced when necessary with filters of like kind and size. Take note of air flow direction marking on filter frame when reinstalling filters.

*NOTE-Filters must be U.L.C. certified or equivalent for use in Canada.*

To change filters, open filter access panel on back side of unit. See figure 17. Lift filter stop to remove filters. See figure 18.

<b>⚠ WARNING</b>	
<b>Units are shipped from the factory with temporary filters. Replace filters before building is occupied. Damage to unit could result if filters are not replaced with approved filters. Refer to appropriate codes.</b>	

### B-Lubrication

All motors are lubricated at the factory. No further lubrication is required.

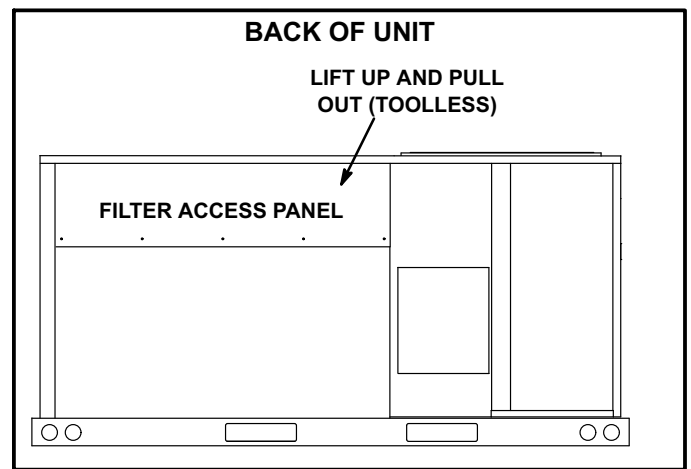

FIGURE 17

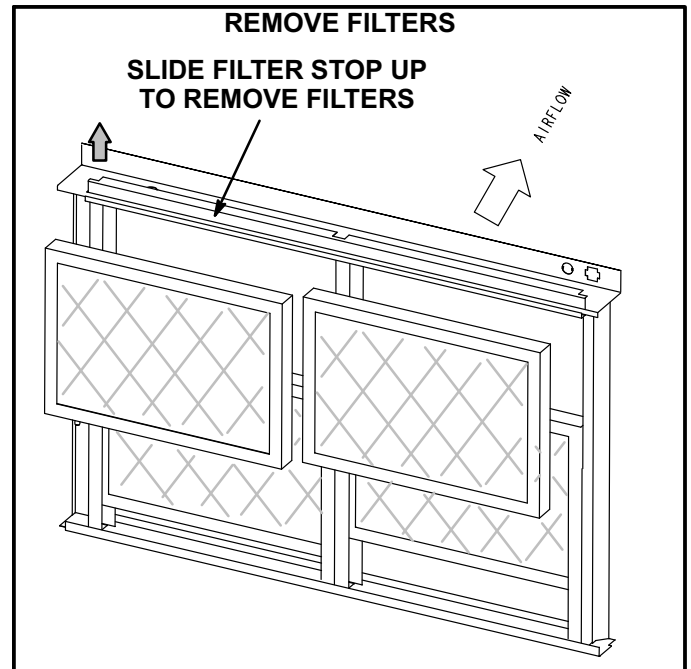

FIGURE 18

### C-Burners

Periodically examine burner flames for proper appearance during the heating season. Before each heating season examine the burners for any deposits or blockage which may have occurred.

Clean burners as follows:

- 1- Turn off both electrical power and gas supply to unit.
- 2- Remove burner compartment access panel.
- 3- Remove top burner box panel.
- 4- Remove screws securing burners to burner support and lift the burners from the orifices. Clean as necessary.
- 5- Locate the ignitor under the right burner. Check ignitor spark gap with appropriately sized twist drills or feeler gauges. See figure 19.

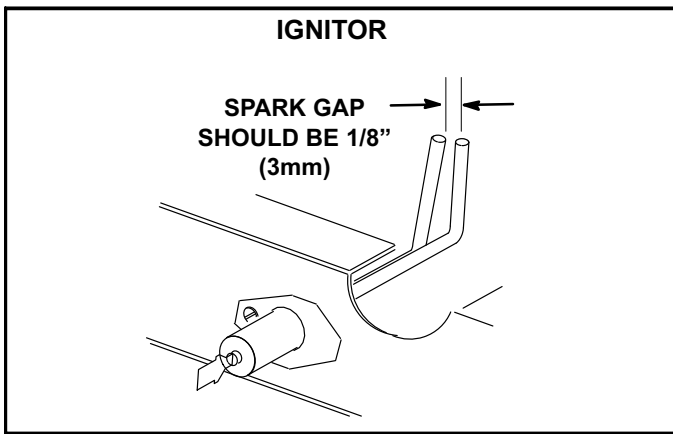

FIGURE 19

6- Replace burners and screws securing burner. See figure 20.

**⚠ WARNING**

**Danger of explosion. Can cause injury or death. Do not overtighten main burner mounting screws. Snug tighten only.**

7- Replace access panel.

8- Restore electrical power and gas supply. Follow lighting instructions attached to unit and use inspection port in access panel to check flame.

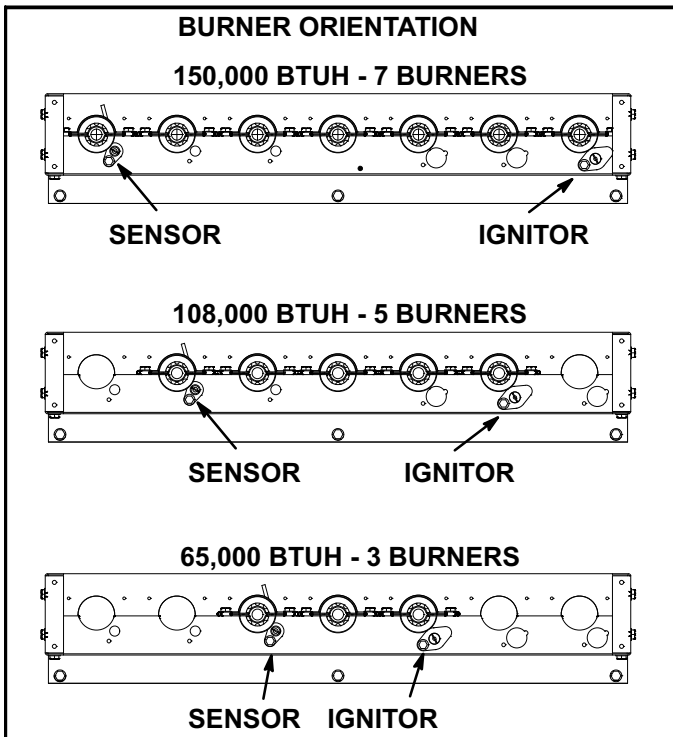

FIGURE 20

### D-Combustion Air Inducer

A combustion air proving switch checks combustion air inducer operation before allowing power to the gas controller. Gas controller will not operate if inducer is obstructed.

Under normal operating conditions, the combustion air inducer wheel should be checked and cleaned prior to the heating season. However, it should be examined periodically during the heating season to establish an ideal cleaning schedule.

Clean combustion air inducer as follows:

- 1- Shut off power supply and gas to unit.
- 2- Remove the access panel located on the right side of the outdoor section under the control box.
- 3- Remove and retain screws securing combustion air inducer to flue box. Remove vent connector. See figure 11.
- 4- Clean inducer wheel blades with a small brush and wipe off any dust from housing. Take care not to damage exposed fan blades. Clean accumulated dust from front of flue box cover.
- 5- Return combustion air inducer motor and vent connector to original location and secure with retained screws. It is recommended that gaskets be replaced during re-assembly.
- 6- Replace the access panel.
- 7- Clean combustion air inlet louvers on heat access panel using a small brush.

### E-Flue Passageway and Flue Box

Remove flue box cover only when necessary for equipment repair. Clean inside of flue box cover and heat exchanger tubes with a wire brush when flue box cover has to be removed. Install a new flue box cover gasket and replace cover. Make sure edges around flue box cover are tightly sealed.

### F-Evaporator Coil

Inspect and clean coil at beginning of each cooling season. Clean using mild detergent or commercial coil cleanser. Flush coil and condensate drain with water taking care not to get insulation, filters and return air ducts wet.

### G-Condenser Coil

Clean condenser coil annually with water and inspect monthly during the cooling season.

*Note - Do not use commercial coil cleaner on the all aluminum coil. Using anything other than water could result in corrosion and/or leaks.*

Clean the all-aluminum coil by spraying the coil steadily and uniformly from top to bottom. Do not exceed 900 psi or a 45 degree angle; nozzle must be at least 12 inches from the coil face. Take care not to fracture the braze between the fins and refrigerant tubes. Reduce pressure and work cautiously to prevent damage.

### H-Supply Blower Wheel

Annually inspect supply air blower wheel for accumulated dirt or dust. Turn off power before attempting to remove access panel or to clean blower wheel.

## VII-ACCESSORIES

The accessories section describes the application of most of the optional accessories which can be factory or field installed to the ZGB units.

### A-Z1CURB

When installing the ZGB units on a combustible surface for downflow discharge applications, a Z1CURB 8-inch, 14-inch, 18-inch, or 24-inch height roof mounting frame is used. The roof mounting frames are recommended in all other applications but not required. If the ZGB units are not mounted on a flat (roof) surface, they **MUST** be supported under all edges and under the middle of the unit to prevent sagging. The units **MUST** be mounted level within 1/16" per linear foot or 5mm per meter in any direction.

The assembled mounting frame is shown in figure 21. Refer to the roof mounting frame installation instructions for details of proper assembly and mounting. The roof mounting frame **MUST** be squared to the roof and level before mounting. Plenum system and block-off panels **MUST** be installed before the unit is set on the mounting frame. Typical roof curbing and flashing is shown in figure 22. Refer to the roof mounting frame installation instructions for proper plenum construction and attachment.

### B-Transitions

Supply/return transitions are field-provided.

### C-Supply and Return Diffusers (all units)

Optional flush mount diffuser/return FD9-65 and extended mount diffuser/return RTD9-65 are available for use with all ZGB units. Refer to manufacturer's instructions included with transition for detailed installation procedures.

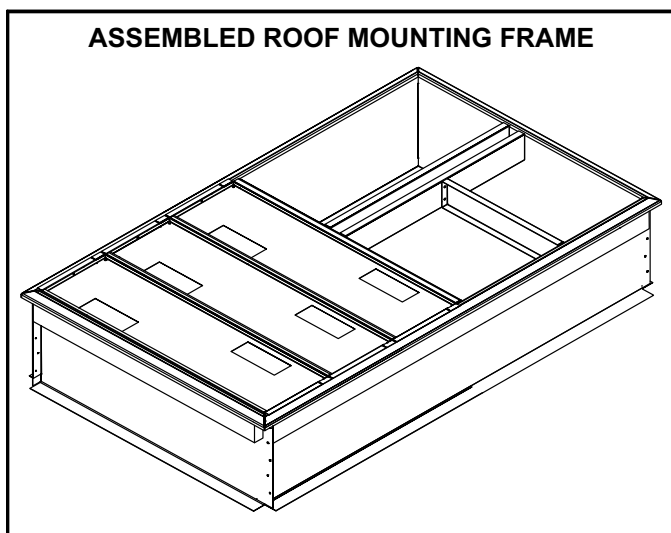

FIGURE 21

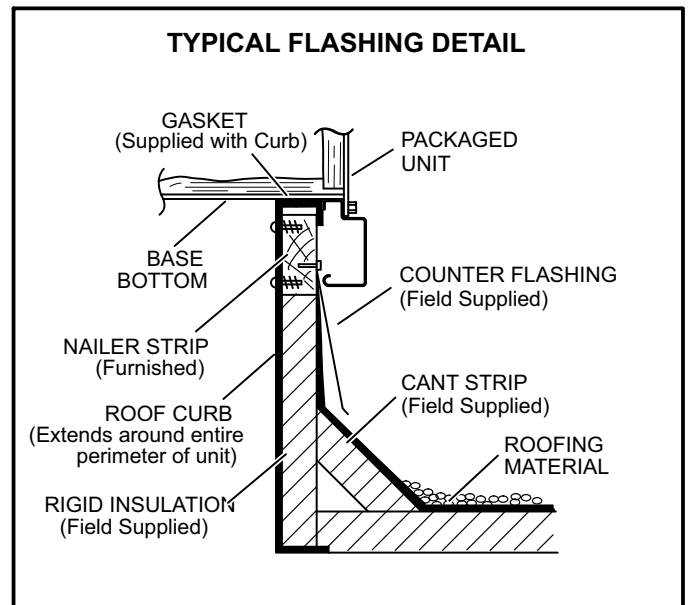

FIGURE 22

### D-Economizer (Field or Factory Installed)

Downflow economizers are a factory-installed option. Downflow and horizontal air flow economizers are a factory- or field-installed option. Economizers are equipped with an A6 enthalpy control, an R1 mixed air sensor and an S175 outdoor sensible sensor. The modulating economizer opens fully to use outdoor air for free cooling when temperature is suitable and opens to minimum position during the occupied time period.

When A6 determines outdoor air is suitable (via input from S175 outdoor air sensor), dampers will modulate open (via B7 damper motor) to maintain 55°F (13°C) supply air (determined by input from R1 mixed/supply air sensor).

The A6 enthalpy control and B7 damper motor are shown in figure 23 for downflow air discharge and figure 24 for horizontal air discharge. The R1 mixed air sensor is shown in figure 25. An A7 outdoor enthalpy sensor is optional and replaces the S175 sensible sensor. See figure 26.

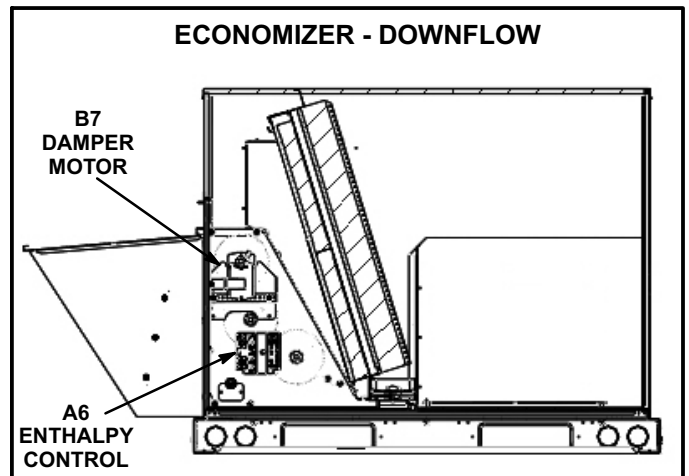
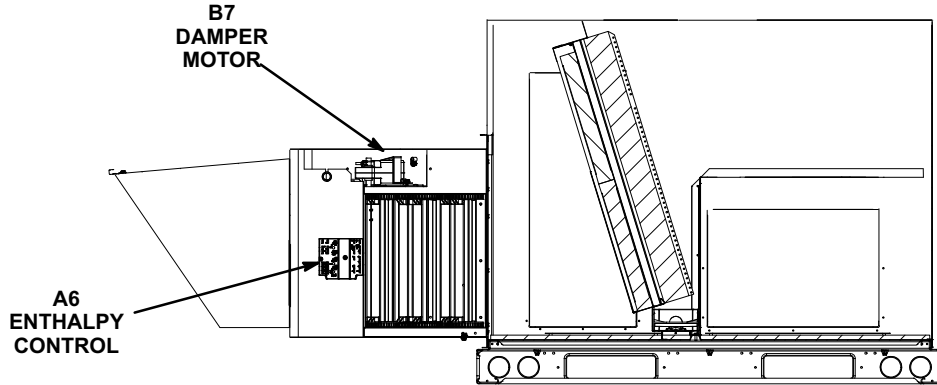
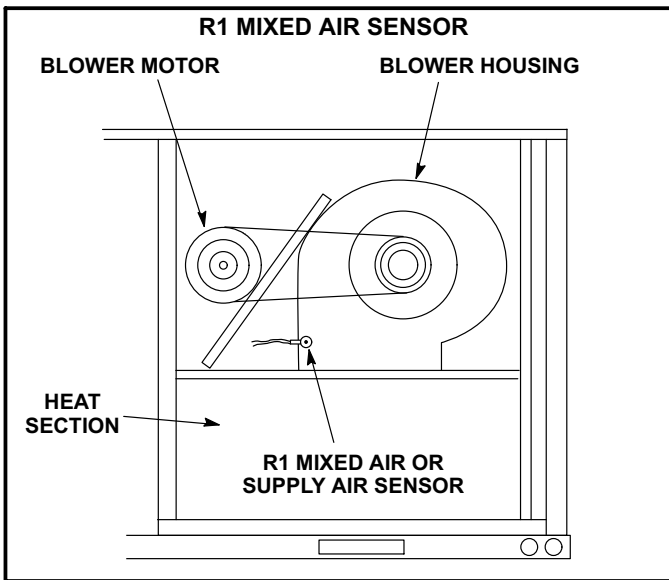

FIGURE 23

**ECONOMIZER - HORIZONTAL  
(FIELD-INSTALLED OPTION)**



**FIGURE 24**



**FIGURE 25**

An optional IAQ sensor (A63) may be used to lower operating costs by controlling outdoor air based on CO<sub>2</sub> level or room occupancy (also called demand control ventilation or DCV). Damper minimum position can be set lower than traditional minimum air requirements; dampers open to traditional ventilation requirements when CO<sub>2</sub> level reaches DCV (IAQ) setpoint.

Refer to instructions provided with sensors for installation.

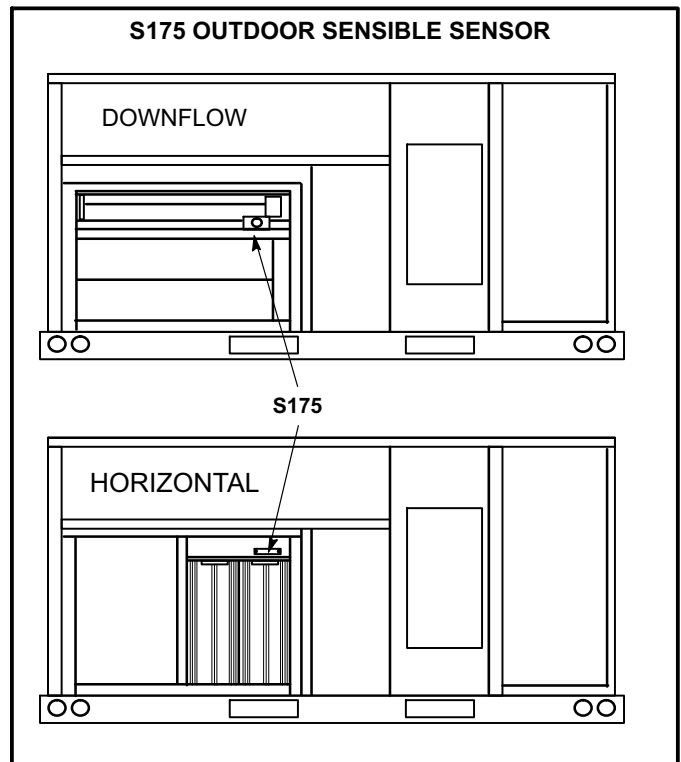
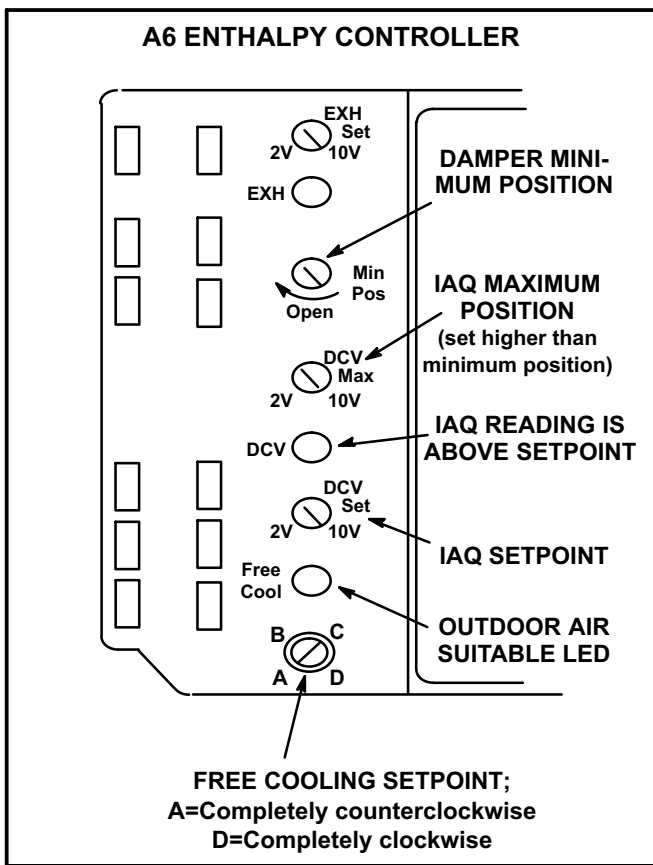

**FIGURE 26**

**A6 Enthalpy Control LEDs**

A steady green Free Cool LED indicates that outdoor air is suitable for free cooling.

When an optional IAQ sensor is installed, a steady green DCV LED indicates that the IAQ reading is higher than setpoint requiring more fresh air. See figure 27.



**FIGURE 27**

**Free Cooling Setpoint**

Outdoor air is considered suitable when temperature and humidity are less than the free cooling setpoints shown in table 13. Setting A is recommended. See figure 27. At setting A, free cooling will be energized when outdoor air is approximately 73°F (23°C) and 50% relative humidity. If indoor air is too warm or humid, lower the setpoint to B. At setting B, free cooling will be energized at 70°F (21°C) and 50% relative humidity.

When an optional A62 differential sensor is installed, turn A6 enthalpy control free cooling setpoint potentiometer completely clockwise to position "D".

**TABLE 13  
ENTHALPY CONTROL SETPOINTS**

Control Setting	Free Cooling Setpoint At 50% RH
A	73° F (23° C)
B	70° F (21° C)
C	67° F (19° C)
D	63° F (17° C)

**Damper Minimum Position**

- 1- Set thermostat to occupied mode if the feature is available. Make sure unit 24V control leads R and OC are connected if using a thermostat which does not have the feature.
- 2- Rotate MIN POS SET potentiometer to approximate desired fresh air percentage.

*Note - Damper minimum position can be set lower than traditional minimum air requirements when an IAQ sensor is specified. Dampers will open to DCV MAX setting (if CO2 is above setpoint) to meet traditional ventilation requirements.*

- 3- Measure outdoor air temperature. Mark the point on the bottom line of chart 1 and label the point "A" (40°F, 4°C shown).
- 4- Measure return air temperature. Mark that point on the top line of chart 1 and label the point "B" (74°F, 23°C shown).
- 5- Measure mixed air (outdoor and return air) temperature. Mark that point on the top line of chart 1 and label point "C" (70°F, 21°C shown).
- 6- Draw a straight line between points A and B.
- 7- Draw a vertical line through point C.
- 8- Draw a horizontal line where the two lines meet. Read the percent of fresh air intake on the side.
- 9- If fresh air percentage is less than desired, adjust MIN POS SET potentiometer higher. If fresh air percentage is more than desired, adjust MIN POS SET potentiometer lower. Repeat steps 3 through 8 until calculation reads desired fresh air percentage.

**DCV Set and Max Settings**

Adjust settings when an optional IAQ sensor is installed. The DCV SET potentiometer is factory-set at approximately 50% of the potentiometer range. Using a standard 1-2000ppm CO<sub>2</sub> sensor, dampers will start to open when the IAQ sensor reads approximately 1000ppm. Adjust the DCV SET potentiometer to the approximate setting specified by the controls contractor. Refer to figure 27.

The DCV MAX potentiometer is factory-set at approximately 50% of the potentiometer range or 6VDC. Dampers will open approximately half way when CO<sub>2</sub> rises above setpoint. Adjust the DCV MAX potentiometer to the approximate setting specified by the controls contractor. Refer to figure 27.

*Note - DCV Max must be set higher than economizer minimum position setting for proper demand control ventilation.*

**CHART 1  
CALCULATE MINIMUM FRESH AIR PERCENTAGE  
MIXED AND RETURN AIR TEMPERATURE**

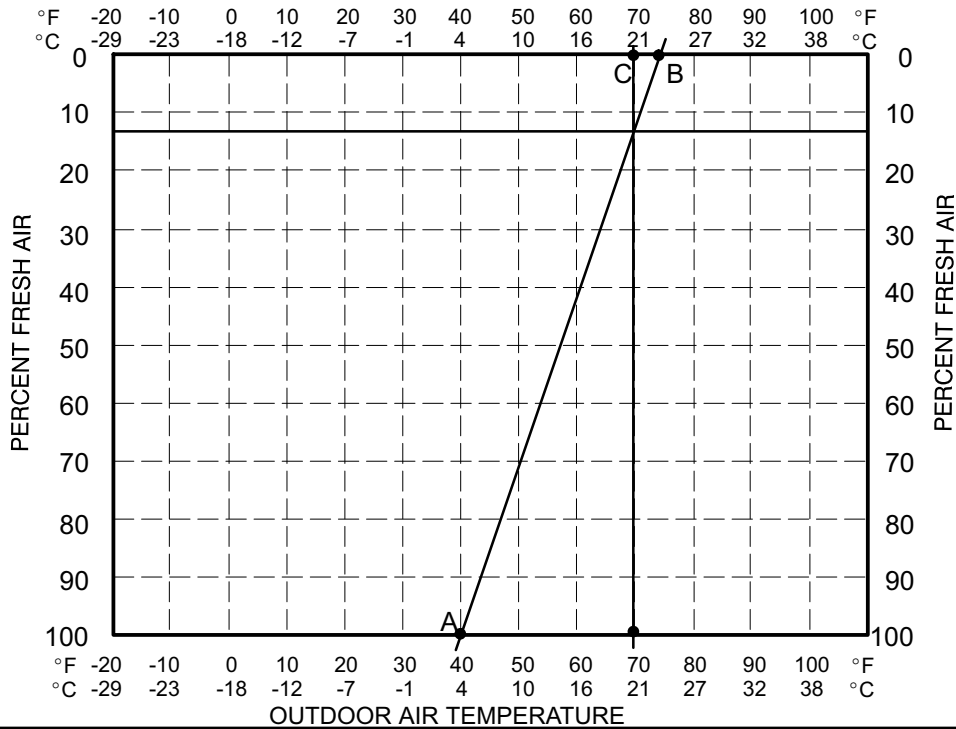

**Economizer Operation**

The occupied time period is determined by the thermostat or energy management system.

**Outdoor Air Not Suitable:**

During the unoccupied time period dampers are closed.

During the occupied time period a cooling demand will open dampers to minimum position and mechanical cooling functions normally.

During the occupied time period dampers will open to DCV MAX when IAQ reading is above setpoint (regardless of thermostat demand or outdoor air suitability).

**Outdoor Air Suitable:**

See table 14 for economizer operation with a standard two-stage thermostat.

During the occupied period, dampers will open to DCV MAX when IAQ reading is above setpoint (regardless of thermostat demand or outdoor air suitability). DCV MAX will NOT override damper full-open position. When an R1 mixed air sensor for modulating dampers is installed, DCV MAX may override damper free cooling position when occupancy is high and outdoor air temperatures are low. If R1 senses discharge air temperature below 45°F (7°C), dampers will move to minimum position until discharge air temperature rises to 48°F (9°C).

**TABLE 14  
ECONOMIZER OPERATION**

OUTDOOR AIR IS SUITABLE FOR FREE COOLING – FREE COOL LED “ON”

THERMOSTAT DEMAND	DAMPER POSITION		MECHANICAL COOLING
	UNOCCUPIED	OCCUPIED	
OFF	CLOSED	CLOSED	NO
G	CLOSED	MINIMUM	NO
Y1	OPEN*	OPEN*	NO
Y2	OPEN*	OPEN*	STAGE 1

\*Dampers will modulate to maintain 55°F (13°C) supply air when an R1 mixed air sensor is installed.

## E-Outdoor Air Dampers

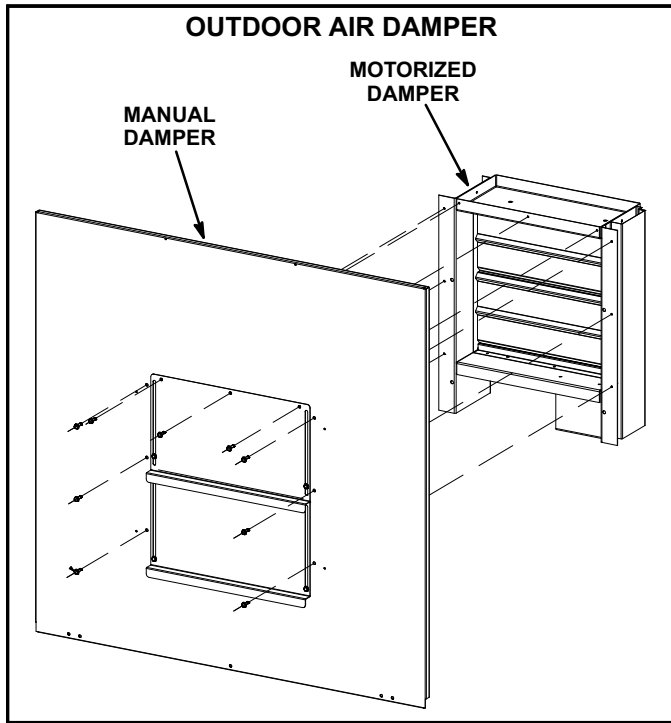

**FIGURE 28**

Z1DAMP21 is a motorized outdoor air damper and Z1DAMP11 is a manual outdoor air damper. See figure 28. Both sets include the outdoor air hood. The dampers provide motorized or manual operation to allow up to 35 percent outside air into the system at all times. Washable filter supplied with the outdoor air dampers can be cleaned with water and a mild detergent. It should be sprayed with Filter Handicoater when dry prior to reinstallation. Filter Handicoater is R.P. Products coating no. 418 and is available as Part No. P-8-5069.

Optional manual and motorized outdoor air dampers provide fresh outdoor air. The motorized damper assembly opens to minimum position during the occupied time period and remains closed during the unoccupied period. Manual damper assembly is set at installation and remains in that position.

Set damper minimum position in the same manner as economizer minimum position. Adjust motorized damper position as shown in figure 29. Manual damper fresh air intake percentage can be determined in the same manner.

## F-Power Exhaust Relay K65 (power exhaust units)

Power exhaust relay K65 is a DPDT relay with a 24VAC coil. K65 is used in all ZGB units equipped with the optional power exhaust dampers. K65 is energized by the economizer enthalpy control A6, after the economizer dampers reach 50% open (adjustable) When K65 closes, exhaust fan B10 is energized.

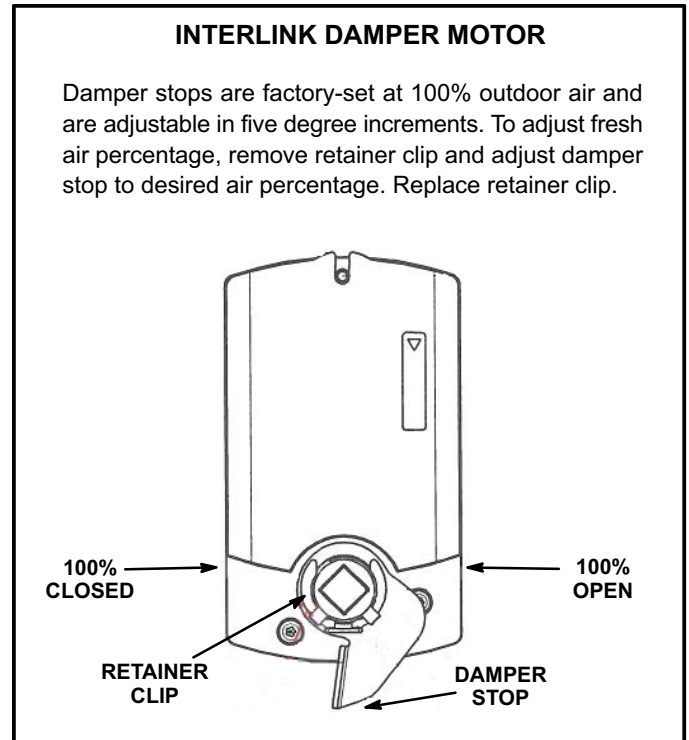

**FIGURE 29**



## G-Power Exhaust Fans (Field-Installed)

Z1PWRE10 is available for downflow units and Z1PWRE15 is available for horizontal air flow units. Fans provide exhaust air pressure relief and also run when return air dampers are closed and supply air blowers are operating. See figure 30, 31 and installation instructions for more detail.

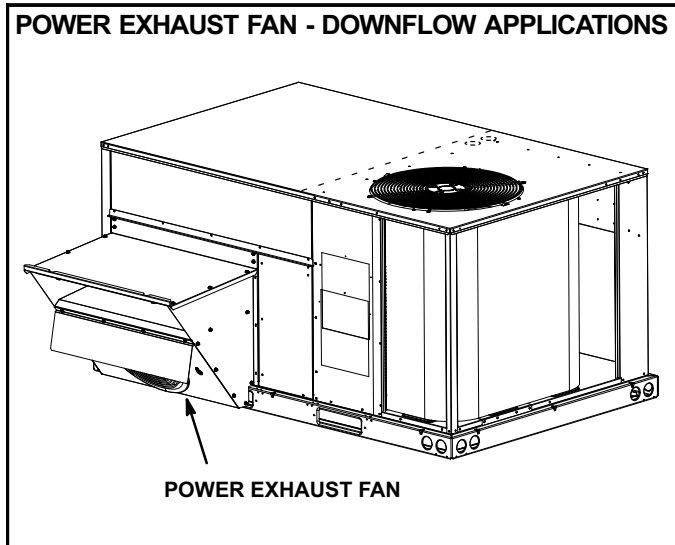

FIGURE 30

## H-Control Systems

Different types of control systems may be used with the ZGB series units. All thermostat wiring is connected to low voltage pigtailed located in the control box. Each thermostat has additional control options available. See thermostat installation instructions for more detail.

### 1- Electro-mechanical thermostat (13F06)

The electro-mechanical thermostat is a two stage heat / two stage cool thermostat with dual temperature levers. A non-switching or manual system switch subbase may be used.

### 2- Electronic thermostat (see price book)

Any two stage heat / two stage cool electronic thermostat may be used.

## I-Indoor Air Quality (CO<sub>2</sub>) Sensor A63

The indoor air quality sensor monitors CO<sub>2</sub> levels and reports the levels to the economizer enthalpy control A6. Controller A6 adjusts the economizer dampers according to the CO<sub>2</sub> levels. The sensor is mounted next to the indoor thermostat or in the return air duct. Refer to the indoor air quality sensor installation instructions for proper adjustment.

## J-LP / Propane Kit (Field-Installed)

All units require a natural to LP /propane kit. For more detail refer to the natural to LP gas changeover kit installation instructions.

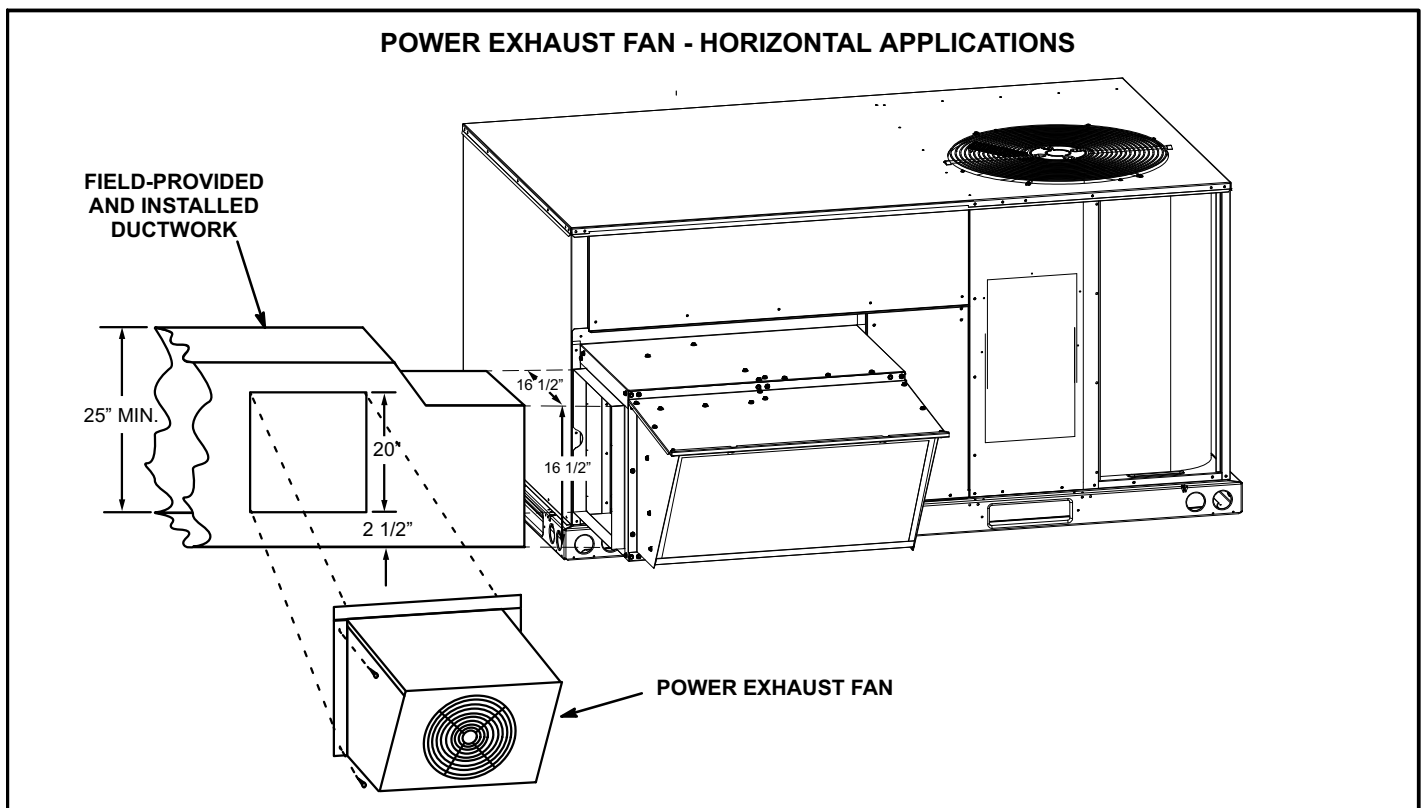

FIGURE 31

# VIII-Wiring Diagrams and Sequence of Operation

KEY	COMPONENT
A2	ELECTRONIC SENSOR
A3	BURNER CONTROL BOARD
A6	SOLID STATE ENTHALPY CONTROL
A7	SOLID STATE ENTHALPY SENSOR
A63	CO2 SENSOR (IAC)
B1	COMPRESSOR 1
B3	BLOWER MOTOR
B4	OUTDOOR FAN MOTOR
B6	COMBUSTION AIR BLOWER MOTOR
B7	ECONOMIZER OR DAMPER MOTOR
B10	EXHAUST FAN MOTOR
C1	OUTDOOR FAN CAPACITOR
C3	CAPACITOR, COMB AIR BLOWER
C6	CAPACITOR, EXHAUST FAN 1
C7	COMPRESSOR 1 HARD START CAPACITOR
C12	DUAL CAPACITOR
CMC3	TIME CLOCK
DL3	DELAY,GAS 2,180 SECONDS, 11,16
DL48	DELAY,CRANKCASE HEATER
DL49	DELAY,BLOWER OFF
DL50	DELAY,1.5 SEC DELAY ON MAKE
E1	SPARK
F1	TRANSFORMER 1 FUSE
FS1	FLAME SENSOR
GV	GAS VALVE
HR1	HEATER, COMPRESSOR 1
K1	COMPRESSOR 1 CONTACTOR
K3	BLOWER CONTACTOR
K8E	TRANSFER RELAY, ECONOMIZER
K10	OUTDOOR FAN RELAY
K31	HARD START RELAY
K37	RELAY, BLOWER
K85	EXHAUST FAN RELAY
K72	GAS 3 RELAY
K191	RELAY,CRANKCASE HEATER
K239	RELAY, Y1/W1 HI-LO SWITCHING RELAY
K250	RELAY, Y2 HIGH SPEED BLOWER
R1	MIXED AIR OR SUPPLY SENSOR
R2	MINIMUM POSITION POTENTIAMETER
R51	RESISTOR, MAT BYPASS
RT2	REMOTE THERMOSTAT SENSOR
RT26	SENSOR, OUTDOOR AIR TEMP
S3	LOW DISCHARGE TEMP LIMIT, COMPRESSOR 1
S4	HIGH PRESSURE LIMIT, COMPRESSOR 1
S6	HIGH TEMPERATURE LIMIT, COMPRESSOR 1
S11	LOW AMBIENT LOW PRESSURE SWITCH
S18	COMBUSTION AIR BLOWER PROVING SWITCH
S40	SWITCH-CRANKCASE HEATER T-STAT
S43	LOW GAS PRESSURE SWITCH

## KEY LIST

S47	FLAME ROLLOUT SWITCH
S59	THERMOSTAT OPEN -20F , CLOSE 10F
S149	OVERFLOW SWITCH
S175	SENSIBLE (55-70) TEMPERATURE THERMOSTAT
T1	TRANSFORMER, CONTROL
T3	COMBUSTION AIR BLOWER TRANSFORMER
T10	EXHAUST FAN TRANSFORMER

J/P #	JACK/PLUG DESCRIPTION
1	GAS LIMIT
2	HEAT
3	ECONOMIZER
4	ECONOMIZER
9	ECONOMIZER
18	EXHAUST FAN
19	COMBUSTION AIR BLOWER
21	COMBUSTION AIR BLOWER
24	EXHAUST FAN
29	GAS VALVE
39	CONTROL INTERFACE
349	DELAY TIMER POWER
350	BLOWER HIGH - LOW MECHANICAL SWITCHING JACK
351	BLOWER HIGH - LOW MECHANICAL SWITCHING JACK

S10PR10MSA/C

# ZGB036, 048, 060, 074 Unit Diagram (1 of 2)

## P, G, J, Y, M Voltage

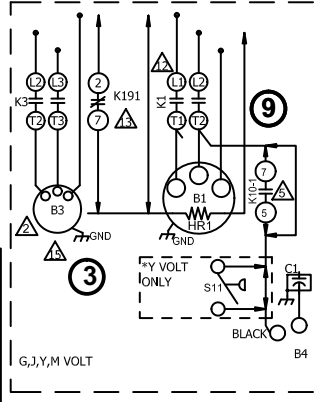
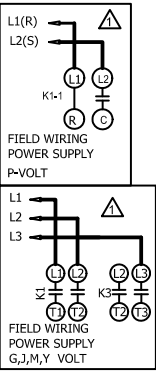
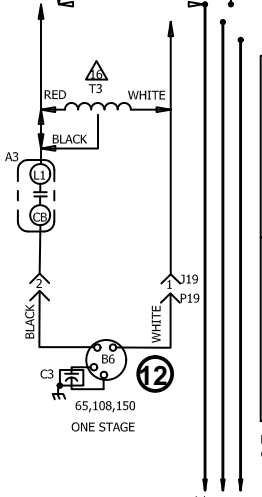
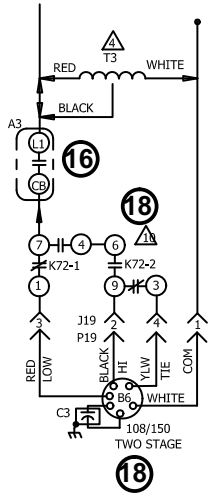
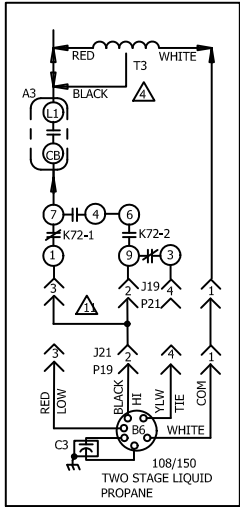
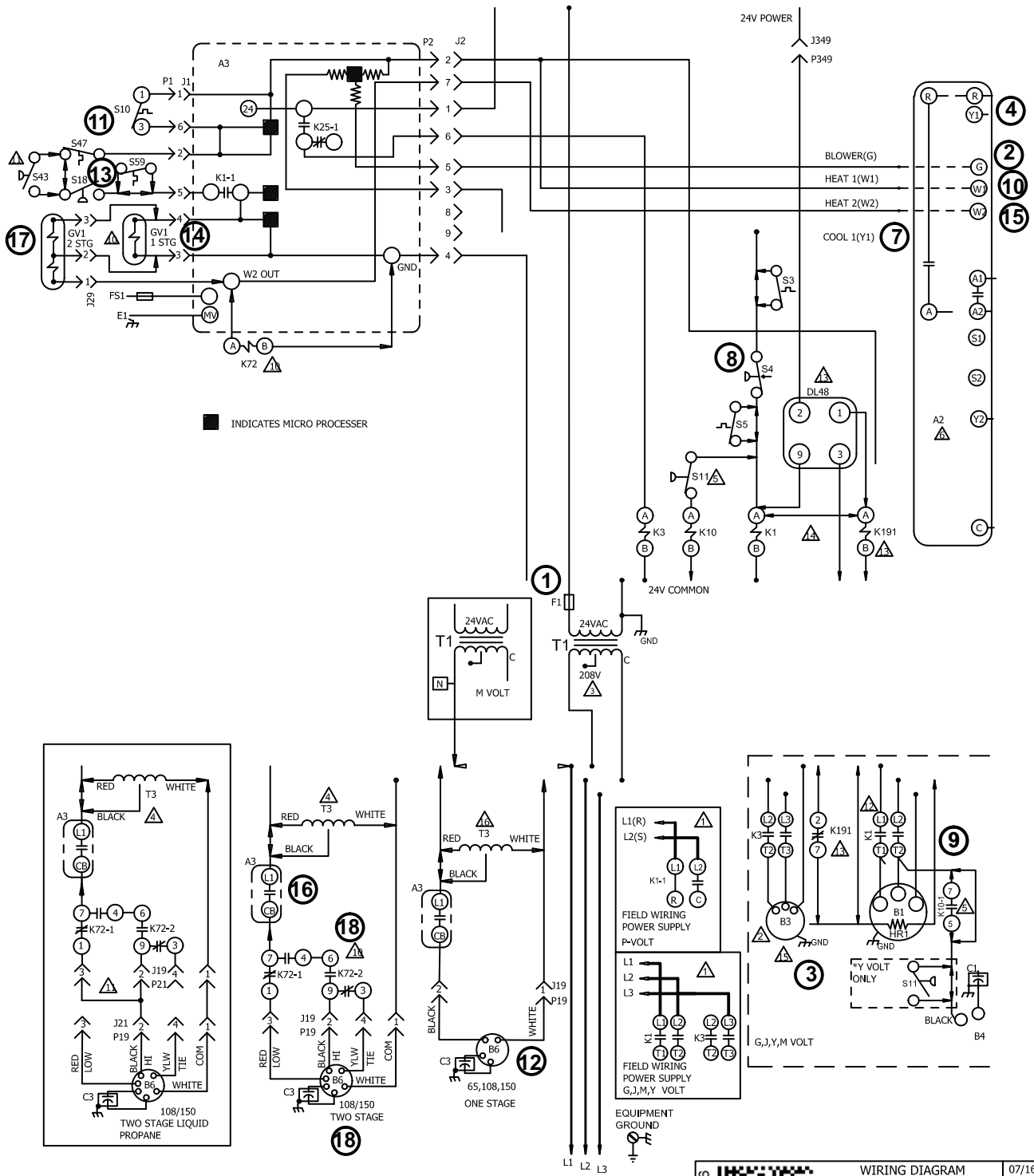

07/16	WIRING DIAGRAM	07/16
	537647-04	
UNIT DIAGRAM		
ZGA 036,048, 060,072,074 ZGB 036,048,060,074		
SECTION ALL		REV. 0
Supersedes	New Form No.	
537647-03	537647-04	

# ZGB036, 048, 060, 074 Unit Diagram (2 of 2)

## P, G, J, Y, M Voltage

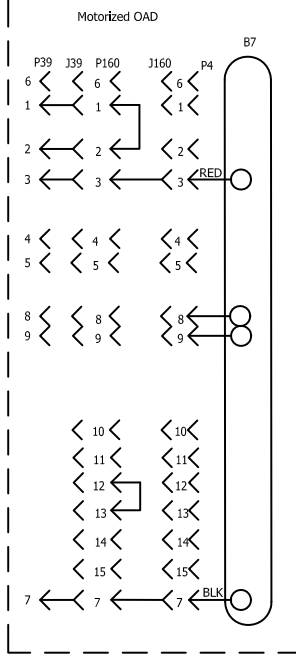
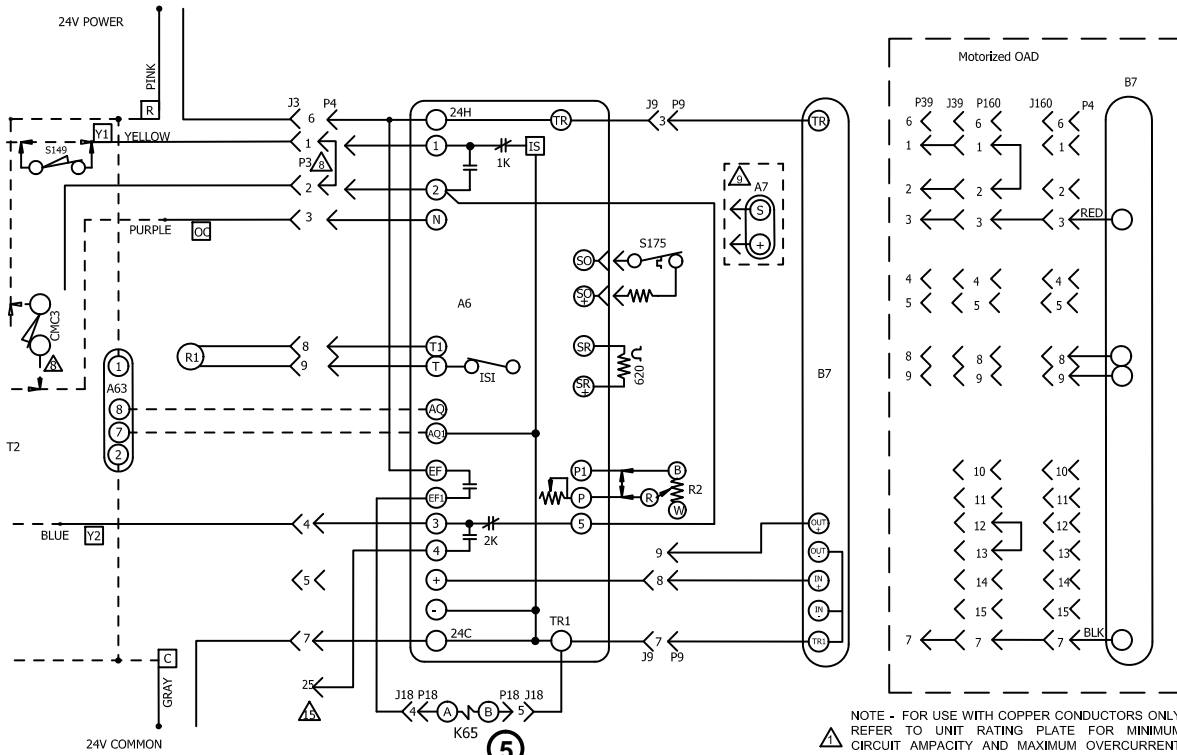

- NOTE - FOR USE WITH COPPER CONDUCTORS ONLY REFER TO UNIT RATING PLATE FOR MINIMUM CIRCUIT AMPACITY AND MAXIMUM OVERCURRENT PROTECTION SIZE.
- IMPORTANT: TO PREVENT MOTOR BURNOUT, NEVER CONNECT MORE THAN ONE MOTOR LEAD TO ANY ONE CONNECTION. TAPE UNUSED MOTOR LEADS
- P, Y VOLT T1 WITH 208V TAP
- T3 USED ON 480V AND 600V UNITS
- LOW AMBIENT KIT
- THERMOSTAT/SENSOR SUPPLIED BY USER
- REMOVE P3 WHEN ECONOMIZER OR OADM IS USED
- TIME CLOCK CONTACTS (OPT) CLOSED OCCUPIED
- A7 ENTHALPY SENSOR MAY BE USED INSTEAD OF S175 TEMPERATURE SWITCH AND RESISTOR
- K72 AND GV1 2 STG ARE USED ON TWO STAGE UNITS
- ADD J21, P21, AND S43 FOR TWO STAGE LIQUID PROPANE UNITS
- ZGA 036,048,060 ONLY
- ZGB MODELS ONLY
- ZGA 072, DL48 NOT USED
- SEE SECTION E DIAGRAMS FOR 2 SPEED BELT DRIVE SYSTEMS
- T3 USED ON 600V UNITS

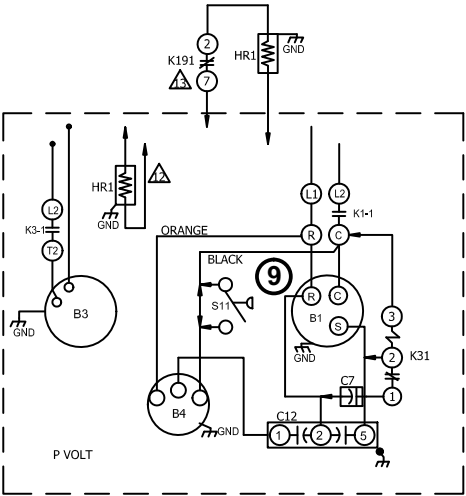
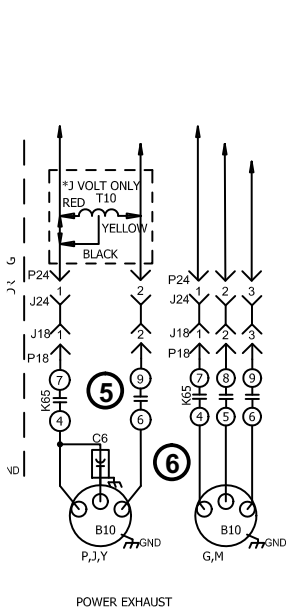

07/16	WIRING DIAGRAM	07/16
537647-04		
UNIT DIAGRAM		
ZGA 036,048, 060,072,074		
ZGB 036,048,060,074		
SECTION ALL		REV. 0
Supersedes	New Form No.	
537647-03	537647-04	

## ZGB036, 048, 060, 074 P, Y, G, J & M Voltage Sequence of Operation

### Power:

1. Line voltage from unit disconnect energizes transformer T1. T1 provides 24VAC power to the unit cooling, heating and blower controls.

### Blower Operation:

2. Indoor thermostat terminal G, via A3 ignition control, energizes blower contactor K3 with 24VAC.
3. N.O. K3 closes, energizing blower B3.

### Economizer Operation:

4. The A6 economizer control module receives a Y1 thermostat demand. If outdoor air is suitable, economizer modulates open (see table 14 in *VII-ACCESSORIES* section).

### Power Exhaust Fan Operation:

5. The A6 economizer control module receives a Y1 thermostat demand and energizes exhaust fan relay K65 with 24VAC at 50% outside air damper open (adjustable).
6. N.O. K65-1 closes, energizing exhaust fan motor B10.

### Cooling Demand

7. First stage cooling demand Y1 and G is energized by the thermostat. G energizes blower.
8. 24VAC is routed through low voltage Y1 lead to optional N.C. compressor low discharge temperature limit S3, N.C. high pressure switch S4 and N.C. compressor high temperature limit S5. Compressor contactor K1 is energized.
9. N.O. K1-1 close energizing compressor B1 and outdoor fan B4.

### First Stage Heat:

10. The thermostat initiates W1 heating demand.
11. 24VAC is routed to ignition control A3. A3 proves N.C. primary limit S10 and N.C. roll-out switch S47.
12. Combustion air inducer blower B6 is energized.
13. After the combustion air inducer B6 has reached full speed, the combustion air proving switch S18 contacts close.
14. After a 30 second delay A3 energizes the ignitor and gas valve GV1 on first stage.

### Second Stage Heat:

15. Additional heating demand from the thermostat initiates W2.
16. A second stage heating demand is received by ignition control A3.
17. A3 energizes gas valve GV1 on second stage.
18. Relay K72-1 terminals 1 and 7 open, 7 and 4 close. K72-2 terminals 6 and 9 close and 9 and 3 open, energizing combustion air inducer B6 on high speed.

### End of Second Stage Heat:

19. Heating demand is satisfied. W2 (second stage) is de-energized.
20. Second stage heat is de-energized on GV1 by ignition control A3.
21. K72 terminals 4 and 7 open and 1 and 7 close. K72 terminals 6 and 9 open, 9 and 3 close. Combustion air inducer B6 is now on low speed.

### End of First Stage Heat:

22. Heating demand is satisfied. W1 (first stage) is de-energized.
23. Ignition A3 is de-energized in turn de-energizing gas valve GV1 and combustion air inducer B6.