



Controlling Your Comfort Room by Room

The ZD series are extruded aluminum parallel blade dampers compete with 24V Power Open/ Power Close Motor. These dampers are shipped complete and ready for installation. The lightweight ZD can be installed in any position in any properly sized duct. These dampers and motor combination are rated for duct pressure up to 2.0" W.C.

Dampers are available in all even sizes from 8"x8" to 36"x24". All dampers are 1/4" undersized from their listed size. Dampers are ordered as ZDSM for side mount, width by height, as the motor and end plate will be on the smaller dimension, for typical insertion into the side/shorter dimension of the duct. The ZDBM denotes bottom mount and is ordered height by width. The motor and end plate are on the longer dimension for typical insertion into either the bottom or top of the duct. Dampers are ordered as ZDSMwwhh or ZDBMhhww, using 2 digits for each dimension. All ZD dampers are shipped in the Open position ready for installation.

The ZDSM & ZDBM can be used for zone control, fresh air intake, ventilation or as the motorized damper for by-pass air when controlled by the Static Pressure Switch (SPS) or Static Pressure Control (SPC). It is also designed to also handle high velocity air conditioning systems up to 2.0"W.C.

The simple 3 wire motor has two light emitting diodes (LED's) to indicate the damper position. The RED LED is lit when the damper is closed and the Green is lit when the damper is open. The MDM also has adjustable minimum position stop located under the motor cover. This motor's energy saving design uses end switches to break power to the motor once the motor reaches the end travel position. This lengthens the motor life and conserves energy. The MDM has been factory tested to over 250,000 cycles.



The MDM Actuator delivers up to 250 in/oz. (15.62 in/lbs.) of torque that powers the RDM open and closed. This powerful motor allows the damper to handle higher static pressures and can be modulated using the SPS or SPC Static Pressure Switch or similar type control.

The MDM is a reversible motor that powers the damper both open and closed. It also has an adjustable stop for a minimum damper position setting.



ZONE DAMPER

With MDM Power Open/Power Close Motor

Model: ZDSM & ZDBM



ZDSM - Side Mount

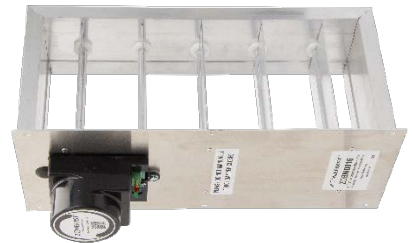

ZDBM - Bottom Mount

Dimensional Drawing (nominal)

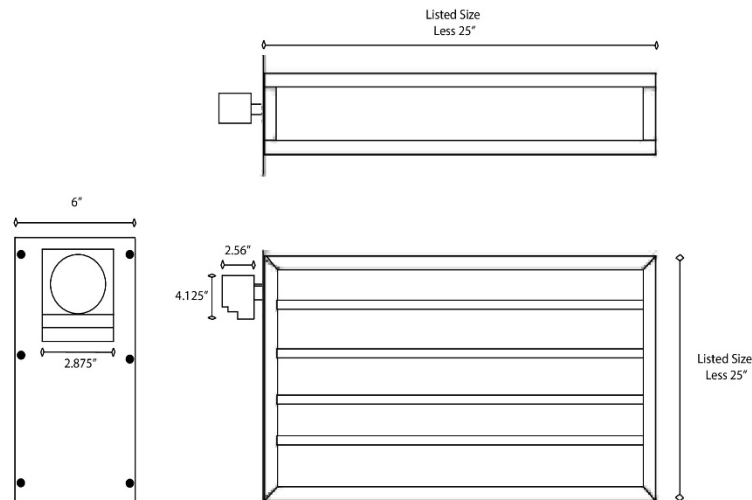

Damper Specifications

Construction – Aluminum Mill Finish, Mitre Angles

Linkage – Zinc plated linkage arm, Delrin bushings

Dimensions – 8"x8" to 36"x24" in 2" increments, 1/4" undersized.

Custom sizes available

Motor Voltage – 24Volts AC, 50/60Hz, 4VA, 1.7A

Torque – 250in/oz. (15.62in/lbs.)

Temperature Rating - 0°F to 150°F Operating, -20°F to 175°F Storage

Humidity – 5% to 95% Non-Condensing

Damper Timing – Nominal 9 Sec. Powered

Connection: Screw Terminals

Static Pressure – Maximum 2.0 "W.C.

INSTALLATION

1. Cut a 4-inch (102-millimeter) opening in one side of the air duct at the location selected. Ensure the opening is cut fully to the top and bottom air duct seams.
2. Slide the damper into the cut opening of the air duct. Ensure the electric actuator is mounted toward the top of the air duct.
3. Secure the damper mounting plate to the air duct with the sheet metal zip screws provided.

Side Mount:

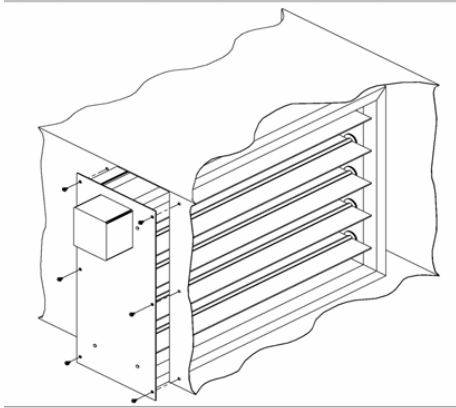

Bottom Mount:

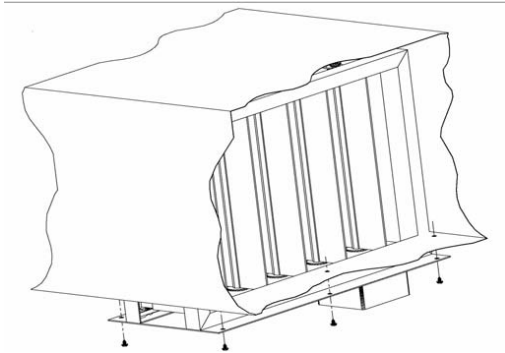

To checkout the operation of the dampers, place 24V across terminals M1 and M4. The damper will open and the Green LED will light at the end of the cycle. Place 24V to terminals M1 and M6 and the damper will close and the Red LED will light at the end of the cycle. All dampers are 100% factory tested.

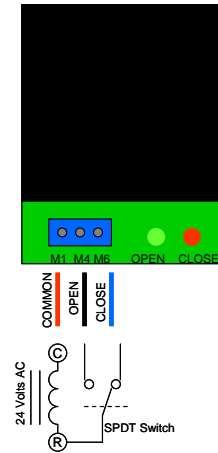

TROUBLESHOOTING

After performing the checkout of the damper, check the motor terminals for 24V across terminals M1 and M4 if the damper should be open, and M1 and M6 if the damper should be closed. If power is not at the proper terminals, check the wiring and control panel for power.

WIRING DIAGRAM

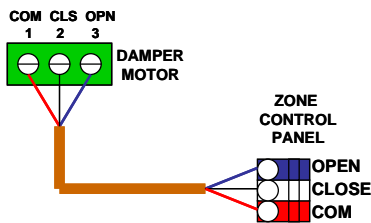

CHECKOUT