

BlueDiamond®

condensate removal pumps

Condensate Removal Pumps

MiniBlue®

The small condensate pump that works and works

2.1 g/hour flow
23 ft head
16.5 ft suction lift



MaxiBlue®

Fit smart, fit fast,
made to last

3.7 g/hour flow
23 ft head
16.5 ft suction lift



MegaBlue®

All the reliability with extra
performance

13.2 g/hour flow
66.5 ft head
23 ft suction lift



- whisper quiet
- patented rotary diaphragm technology
- unrivalled low power consumption
- no maintenance or servicing required
- ultra reliable multi year warranty
- self priming runs wet or dry
- quick and easy to install
- tolerates suspended solids
- positive displacement pump so no siphoning devices required



Plenum Rated

3 year
Warranty

Performance

- 3.7 g/hour flow
- 23 ft head
- 16.5 ft suction lift
- quiet 21dB
- integral fail safe alarm



MaxiBlue® uses the same advanced unique technology as the Blue Diamond® range. Designed for high humidity environments it benefits from being a small powerful pump that is controlled by our patented sensing technology - only senses when water is present offering an energy efficient drainage solution.

With a higher performance the MaxiBlue® is ideally suited for mid range air conditioning systems. Its exceptional reliability is backed by a multi year warranty and class leading performance/suction lift has led it to be installed in environments that are both demanding and expensive to access for maintenance.

Model	110v	208v - 230v	Max Current Draw		Hz
			110V	230V	
Reservoir	X87 - 711	X87 - 721	0.7A	0.35A	50/60
Temp Sensor	X87 - 713	X87 - 723	0.7A	0.35A	50/60
DrainStik	X87 - 712	X87 - 722	0.7A	0.35A	50/60

Tel: +1 770 831 1122

Email: info@bluediamondpumps.com

Web: www.bluediamondpumps.com

3 year
warranty

MaxiBlue options



Reservoir Sensing
with Alarm Contacts



Temperature sensing



DrainStik

Optional Accessories



16ft Extension Cable



Mounting Feet



MultiTank

Performance/Technical



MaxiBlue®
Fit smart, fit fast, made to last

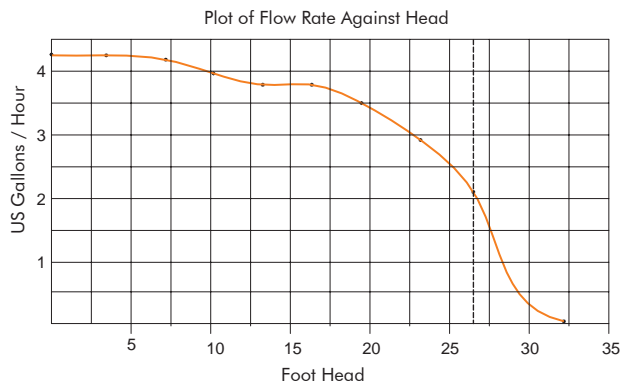

- Proven rotary diaphragm technology
- Flow rate up to 3.7 g/hr
- Dry suction lift up to 16.5 ft
- Self priming
- Energy efficient
- Exceptionally quiet (21dB) and no vibrations
- Powered by unique water sensors
- Thermally protected
- Integral overflow safety switch

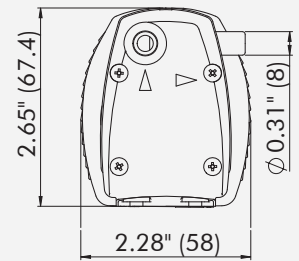

Specifying MaxiBlue®

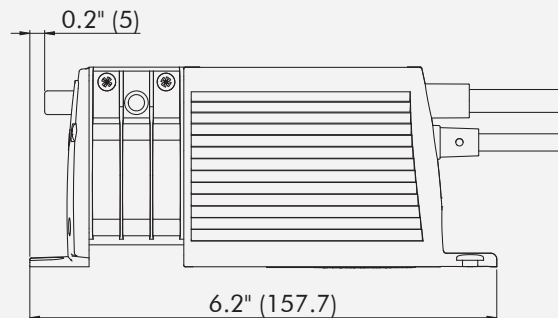
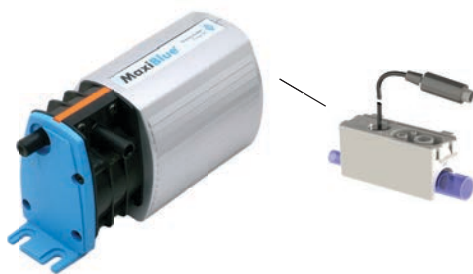

dimensions
in inches
weight 1.5lb

Siting - Installation Possibilities

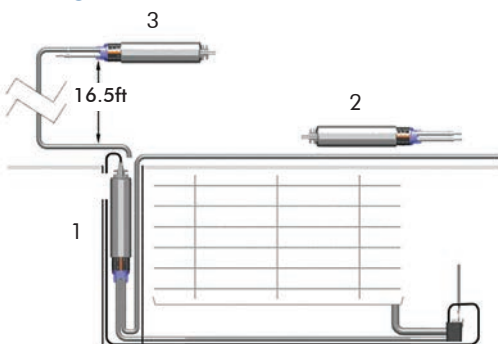

Reservoir Sensor (energy efficient) - Connect drip tray to reservoir in which the presence of condensate trips the hi-low solid state level sensors to switch pump on/off. Runs pump only when condensate produced.

Alarm shuts off A/C in fault mode, restarts when clear. Volt free, high level alarm is suitable to connect into City Multi with either CN4F or CN31 drain safety connector, Mr Slim P&M series.

- ① inside line hide ② above ceiling ③ remote

MaxiBlue® pump is slim enough to fit into line hide or ducting, powerful enough for distant location and quiet enough for ceiling mounting. It's your choice. Commissioning is so easy, link pump to sensing option with single wire DIN plug and connect in/out tubing provided - plug and play, fit and forget!

Revolutionary pumping principle



Patented rotary diaphragm pump

Making all these advantages possible is our advanced rotary diaphragm technology. The condensate is drawn into the pump by vacuum then mechanically driven with a re-inforced elastomer diaphragm to the outlet under pressure. This system even tolerates suspended solids and light slurries and also happily runs dry.

MaxiBlue® - Fit smart, fit fast, made to last

Too good to be true?

- 13.2 g/hr flow
- 66.5ft metres head
- 23ft suction lift/self priming
- ultra reliable – multi year warranty
- whisper quiet
- slimline/lightweight
- integral failsafe alarm



MegaBlue® has the performance to overcome installation difficulties - just plug and play, fit and forget. You can prevent call-outs to stalled or clogged mini pumps and forget servicing split peristaltic tubes and worn gearboxes.

Proven in service the revolutionary patented principle makes it inherently reliable and is backed by our multi year warranty. Who else offers that? With new low cost MegaBlue® there's no cost penalty up front but big savings on installation and in service beyond.

Keep in the van to keep out of trouble.

Model	208v - 230v	Max Current Draw		Hz
		110V	230V	
Reservoir	X87 - 835	0.3A	0.15A	50-60
Temp Sensor	X87 - 833	0.3A	0.15A	50-60
DrainStik	X87 - 834	0.3A	0.15A	50-60

3 year
Warranty

Tel: +1 770 831 1122

Email: info@bluediamondpumps.com

Web: www.bluediamondpumps.com

MegaBlue® options



Reservoir Sensing with Alarm Contacts



Temperature Sensing



DrainStik

Optional Accessories



16ft Extension Cable



Mounting Feet



MultiTank

Performance/Technical

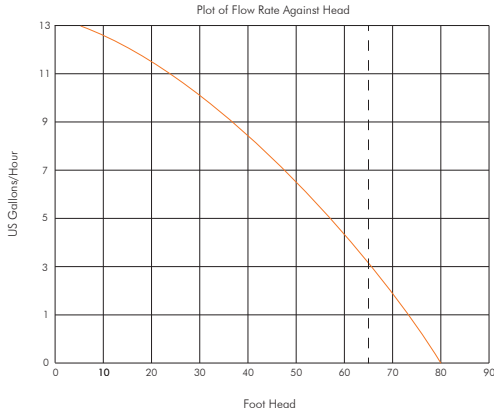

- Exceptional performance from a small package:
- Flow rate up to 13.2 g/hr
- Max head 66.5 ft (pumps up 6 storeys!)
- Dry suction lift 23 ft - self priming
- Very quiet and low vibration
- Thermally protected pump

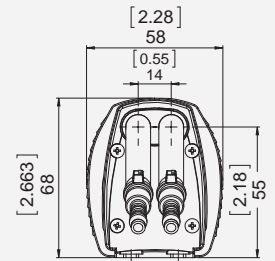

Specifying MegaBlue®

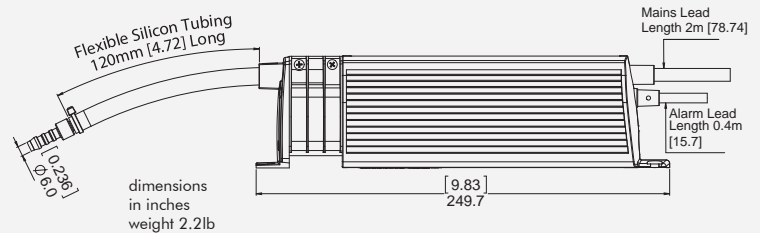

Pump kit - Complete with in and out tubing and connections, anti vibration feet and mountings, integral alarm module and 3 wire power cord (6.5ft)

Reservoir Sensor (energy efficient) - Connect drip tray to reservoir in which the presence of condensate trips the hi-low solid state level sensors to switch pump on/off. Runs pump only when condensate produced.

Alarm shuts off A/C in fault mode, restarts when clear. Volt free, high level alarm is suitable to connect into City Multi with either CN4F or CN31 drain safety connector, Mr Slim P&M series.

Siting - Installation Possibilities

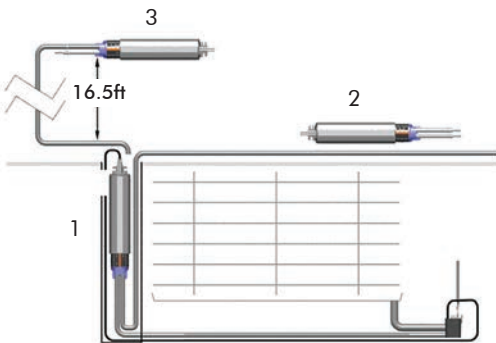

- ① inside line hide ② above ceiling ③ remote

MegaBlue® pump is slim enough to fit into line hide or ducting, powerful enough for distant location and quiet enough for ceiling mounting. It's your choice. Commissioning is so easy, link pump to sensing option with single wire DIN plug and connect in/out tubing provided - plug and play, fit and forget!

Revolutionary pumping principle



Patented rotary diaphragm pump.

Making all these advantages possible is our advanced rotary diaphragm technology. The condensate is drawn into the pump by vacuum then mechanically driven within a re-inforced elastomer diaphragm to the outlet under pressure. This system even tolerates suspended solids and light slurries and also happily runs dry.

MegaBlue® - All the reliability with extra performance

Ultra reliable - incorporates electronic level sensing with no moving parts

Quiet - reliably removes condensate

Multiport - up to 6 condensate lines

Impact resistant - exceptionally high durability

Fit fast - floor or wall mounted

Tank Material - UL94-V0 rated ABS



The MultiTank is favoured among architects and design consultants and is available for using with either MegaBlue® or MaxiBlue® pumps. The tank incorporates an energy efficient solid state level sensor which eliminates the use of moving floats - which often become stuck. By manifolding a number of fan coil units into the 49.9 ounce MultiTank, it offers the installer complete flexibility surrounding any multi-unit installation.

MultiTank can prevent installation difficulties against centrifugal tank pumps which don't have the ability to run dry. By incorporating either the MaxiBlue® or MegaBlue® the user can prevent regular service call-outs to peristaltic tank units that have split tubes or worn gearboxes.

MultiTank is supplied with an integrated safety switch option designed to either switch the A/C unit off and leave the pump running continuously, or wire into BC controller to independently control fail safe alarm function. The MultiTank offers exceptional reliability previously unseen and is supported with our 3 year warranty.

Tel: +1 770 831 1122

Email: info@bluediamondpumps.com

Web: www.bluediamondpumps.com

Installation ideas

MaxiBlue®



MegaBlue®



Application ideas

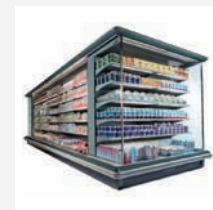

3 year
warranty

MultiTank
connecting multiple lines into
one BlueDiamond®

Revolutionary Sensory Technology



Specifying MultiTank

Option 1

MaxiBlue®



Option 2

MegaBlue®



Thermistor Technology

With no moving parts the MultiTank offers a reliable alternative to stuck or sunken float switches. Incorporating our patented and proven thermistor technology the hi-low solid state level sensor only runs the pump when condensate is produced. With no moving parts to become clogged or stuck it is an ideal alternative to existing float switches.

Option 1: MultiTank with MaxiBlue® - 3.6 gallons/hour

Designed for high lift applications (26.2ft) the MultiTank and MaxiBlue® make an ideal combination. Quiet enough for ceiling mounting and powerful enough for remote location makes a wide variety of installation possibilities a lot faster and simpler.

Option 2: MultiTank with MegaBlue® - 13 gallons/hour

Offering exceptional performance the MegaBlue® can remove condensate far away and fast. With a head of 65.5ft (6 stories!) the MultiTank and MegaBlue® can be used as a remote central collection point for condensate drainage.

SAFETY WARNINGS

- Always ensure that the MultiTank is secured and cannot be knocked over
- It is essential that MultiTank is installed level
- Temperature range 32-104°F
- Integral fail safe alarm
- Alarm shuts AC off in fault mode, restarts when clear.

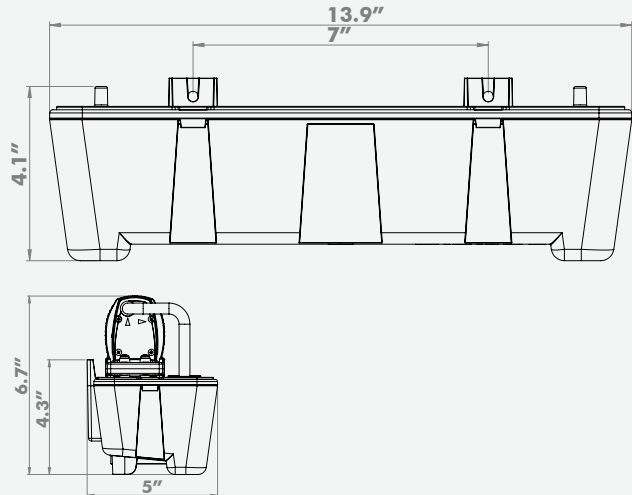

MultiTank - Connecting multiple lines into one BlueDiamond®

Blue Diamond Pumps Inc

4850, Golden Parkway, Suite B, 409, Buford, GA30518, USA

Tel: +1 770 831 1122 Fax: +1 770 831 9888

Email: info@bluediamondpumps.com

www.bluediamondpumps.com

Blue Diamond
Pumps Inc

BlueDiamond®

condensate removal pumps

Condensate Removal Pumps



3 year
Warranty

MiniBlue®

The small condensate pump that works and works

2.1 g/hour flow
23 ft head
16.5 ft suction lift

MaxiBlue®

Fit smart, fit fast, made to last

3.7 g/hour flow
23 ft head
16.5 ft suction lift

MegaBlue®

All the reliability with extra performance

13.2 g/hour flow
66.5 ft head
23 ft suction lift

Specifying BlueDiamond

BlueDiamond pumps can fit or retro-fit around any installation

MiniBlue® 110v X87-505
208-230v X87-512

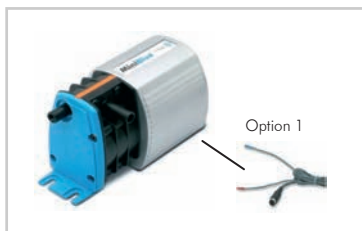

up to 27,000 BTU

MaxiBlue® 110v X87-711
208-230v X87-721

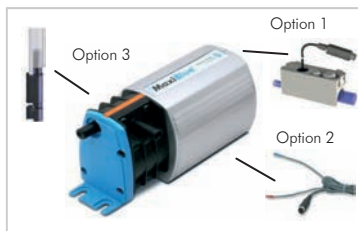

up to 48,000 BTU

MegaBlue® 110-230V
X87-835

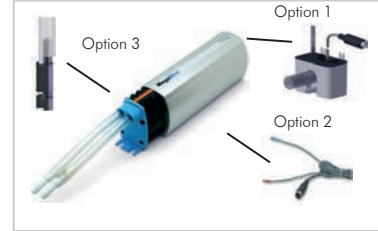

up to 170,000 BTU

N.B 0.3 g per hour = 3,400 BTU per hour

- Self priming
- Whisper quiet
- Can run dry without overheating
- Can be mounted in any orientation
- Plenum rated
- 3 year warranty

BlueDiamond®

condensate removal pumps

Condensate Removal Pumps



MiniBlue®

The small condensate pump that works and works and works

2.1 g/hour flow
23 ft head
16.5 ft suction lift



Temperature Sensing



MaxiBlue®

Fit smart, fit fast, made to last

3.7 g/hour flow
23 ft head
16.5 ft suction lift



DrainStik



Reservoir Sensing

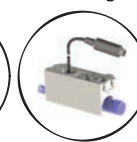

Temperature Sensing



MegaBlue®

All the reliability with extra performance

13.2 g/hour flow
66.5 ft head
23 ft suction lift



DrainStik



Reservoir Sensing

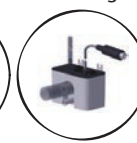

Temperature Sensing



Accessories



- 110v, 208v-230v voltage options
- whisper quiet
- patented rotary diaphragm technology
- unrivalled low power consumption
- no maintenance or servicing required
- integral fail safe alarm
- self priming runs wet or dry
- quick and easy to install
- tolerates suspended solids
- positive displacement pump so no siphoning devices required

BlueDiamond®

condensate removal pumps

Condensate Removal Pumps In The Box

cUL^{us} Included

MiniBlue®



Wire Ties



Rigid Stepped Adaptor



Flexible Stepped Adaptor



Sensing Options

*Pump supplied with one option



Option B

Temperature Sensing

Included

MaxiBlue®



Wire Ties



Rigid Stepped Adaptor



Flexible Stepped Adaptor



Sensing Options

*Pump supplied with one option



Option A

Reservoir Sensing with Alarm Contacts



Option B

Temperature Sensing



Option C

DrainStik

Included

MegaBlue®



Wire Ties



Rigid Stepped Adaptor



Flexible Stepped Adaptor



Sensing Options

*Pump supplied with one option



Option A

Reservoir Sensing with Alarm Contacts



Option B

Temperature Sensing



Option C

DrainStik

BlueDiamond®

condensate removal pumps

Condensate Removal Pumps Sensing Options



MiniBlue®

The small condensate pump that works and works and works



Option B

Temp Sensor

Product Code: X87-505 (110V)
X87-512 (230V)

MaxiBlue®

Fit smart, fit fast, made to last



Option A

Reservoir

Product Code: X87-711 (110V)
X87-721 (208V/230V)

OR

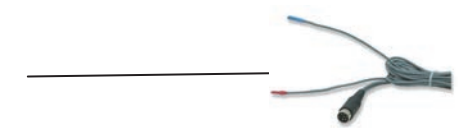

Option B

Temp Sensor

Product Code: X87-713 (110V)
X87-723 (208V/230V)

OR



Option C

DrainStik

Product Code: X87-712 (110V)
X87-722 (208V/230V)

MegaBlue®

All the reliability with extra performance



Option A

Reservoir

Product Code: X87-835 (110V-230V)

OR

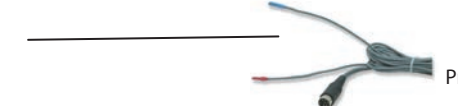

Option B

Temp Sensor

Product Code: X87-833 (110V-230V)

OR

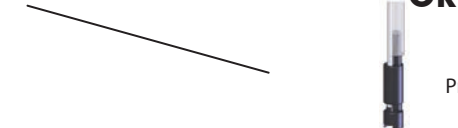

Option C

DrainStik

Product Code: X87-834 (110V-230V)

BlueDiamond®

condensate removal pumps

Condensate Removal Pumps Accessory Options



MiniBlue®

The small condensate pump that works and works and works









-  Rigid Stepped Adaptor
Product Code: C01-226
-  Flexible Stepped Adaptor
Product Code: C01-231
-  16ft Extension Cable
Product Code: C13-103
-  Temp Sensor
Product Code: S12-002

MaxiBlue®

Fit smart, fit fast, made to last



-  Rigid Stepped Adaptor
Product Code: C01-226
-  Flexible Stepped Adaptor
Product Code: C01-231
-  16ft Extension Cable
Product Code: C13-103
-  Temp Sensor
Product Code: S12-002
-  Reservoir Sensor
Product Code: C21-013
-  DrainStik
Product Code: S12-004
-  MultiTank
Product Code: C21-014

MegaBlue®

All the reliability with extra performance



-  Rigid Stepped Adaptor
Product Code: C01-226
-  Flexible Stepped Adaptor
Product Code: C01-231
-  16ft Extension Cable
Product Code: C13-103
-  Temp Sensor
Product Code: S12-002
-  Reservoir Sensor
Product Code: C21-008
-  DrainStik
Product Code: S12-004
-  MultiTank
Product Code: C21-014

BlueDiamond®

condensate removal pumps

Condensate Removal Pumps 110V

MiniBlue®

The small condensate pump that works and works and works

2.1 g/hr flow
23ft head
16.5ft suction lift



MaxiBlue®

Fit smart, fit fast, made to last

3.7 g/hr flow
23ft head
16.5 suction lift



MegaBlue®

All the reliability with extra performance

13.2 g/hr flow
66.5ft head
23ft suction lift



Part No.	Type	Description	Price	Carton Quantities
X87 - 505		MiniBlue & Temp. Sensor	\$87.74	25
X87 - 711		MaxiBlue & Reservoir	\$113.42	25
X87 - 712		MaxiBlue & DrainStik	\$113.42	25
X87 - 713		MaxiBlue & Temp. Sensor	\$113.42	25
X87 - 835		MegaBlue & Reservoir	\$153.01	10
X87 - 833		MegaBlue & Temp. Sensor	\$153.01	10
X87 - 834		MegaBlue & DrainStik	\$153.01	10

CR Plug



DrainStik



MaxiBlue Reservoir



MegaBlue Reservoir



Temp. Sensor



Extension Cable



Stepped Adapter



MultiTank Kit



Mounting Feet



Part No.	Type	Description	Price	Carton Quantities
C01 - 226		Rigid Stepped Adapter	\$8.56	10
C01 - 231		Flexible Stepped Adapter	\$8.56	10
P02 - 048		MiniBlue/MaxiBlue/MegaBlue CR Plug	\$5.35	10
C13 - 103		MiniBlue/MaxiBlue/MegaBlue 5m Extension Cable	\$21.94	10
S12 - 002		MiniBlue/MaxiBlue/MegaBlue Temp. Sensor	\$49.76	1
S12 - 004		MaxiBlue/MegaBlue DrainStik	\$49.76	1
C21 - 013		MaxiBlue Reservoir	\$49.76	1
C21 - 008		MegaBlue Reservoir	\$49.76	1
C21 - 014		MultiTank Kit	\$49.76	12
F10 - 011		MiniBlue/MaxiBlue/MegaBlue Mounting Feet	\$10.97	25

Blue Diamond Pumps Inc is pleased to now include free Freight on complete carton Purchase Orders shipped within Contiguous US (lower 48), effective January 1, 2015

BlueDiamond®

condensate removal pumps

Condensate Removal Pumps 230V

MiniBlue®

The small condensate pump that works and works and works

2.1 g/hr flow
23ft head
16.5ft suction lift



MaxiBlue®

Fit smart, fit fast, made to last

3.7 g/hr flow
23ft head
16.5 suction lift



MegaBlue®

All the reliability with extra performance

13.2 g/hr flow
66.5ft head
23ft suction lift



Part No.	Type	Description	Price	Carton Quantities
X87 - 512		MiniBlue & Temp. Sensor	\$95.23	25
X87 - 721		MaxiBlue & Reservoir	\$116.63	25
X87 - 722		MaxiBlue & DrainStik	\$116.63	25
X87 - 723		MaxiBlue & Temp. Sensor	\$116.63	25
X87 - 835		MegaBlue & Reservoir	\$153.01	10
X87 - 833		MegaBlue & Temp. Sensor	\$153.01	10
X87 - 834		MegaBlue & DrainStik	\$153.01	10

CR Plug



DrainStik



MaxiBlue Reservoir



MegaBlue Reservoir



Temp. Sensor



Extension Cable



Stepped Adapter



MultiTank Kit



Mounting Feet



Part No.	Type	Description	Price	Carton Quantities
C01 - 226		Rigid Stepped Adapter	\$8.56	10
C01 - 231		Flexible Stepped Adapter	\$8.56	10
P02 - 048		MiniBlue/MaxiBlue/MegaBlue CR Plug	\$5.35	10
C13 - 103		MiniBlue/MaxiBlue/MegaBlue 5m Extension Cable	\$21.94	10
S12 - 002		MiniBlue/MaxiBlue/MegaBlue Temp. Sensor	\$49.76	1
S12 - 004		MaxiBlue/MegaBlue DrainStik	\$49.76	1
C21 - 013		MaxiBlue Reservoir	\$49.76	1
C21 - 008		MegaBlue Reservoir	\$49.76	1
C21 - 014		MultiTank Kit	\$49.76	12
F10 - 011		MiniBlue/MaxiBlue/MegaBlue Mounting Feet	\$10.97	25
C13 - 192		Alarm Extension Cable	\$13.91	10

Blue Diamond Pumps Inc is pleased to now include free Freight on complete carton Purchase Orders shipped within Contiguous US (lower 48), effective January 1, 2015