

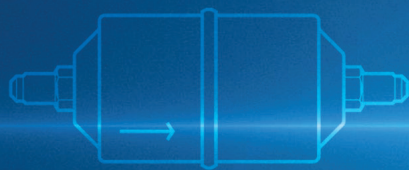

Quick Select Guide 2013

# Automatic controls, compressors and condensing units for HVAC/R wholesalers, contractors and installers

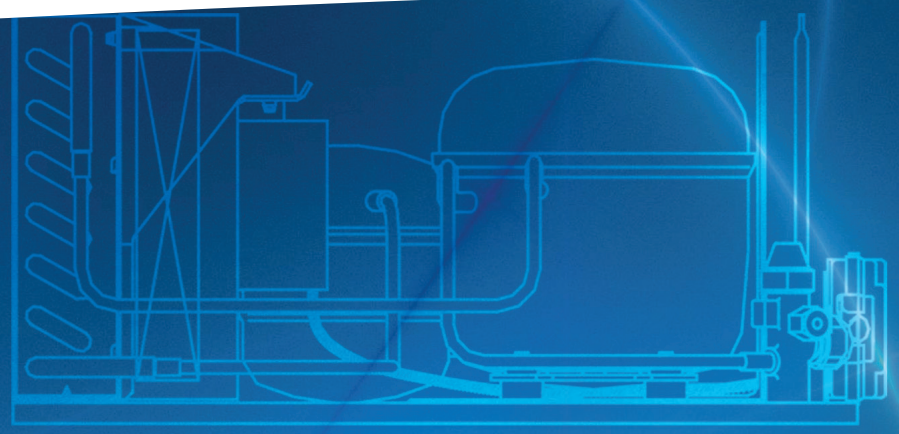

# 17

## products in one quick select guide

The most frequently used refrigeration products from the extended Danfoss ranges have been collected. A time saving tool to find exactly what you are looking for.



124	10314
202	10314
90	10312
14912	3612
60	13514
164	13514
112	13514
147	13514
88	13514
0014	13514
112	13514

## Quick Select Guide

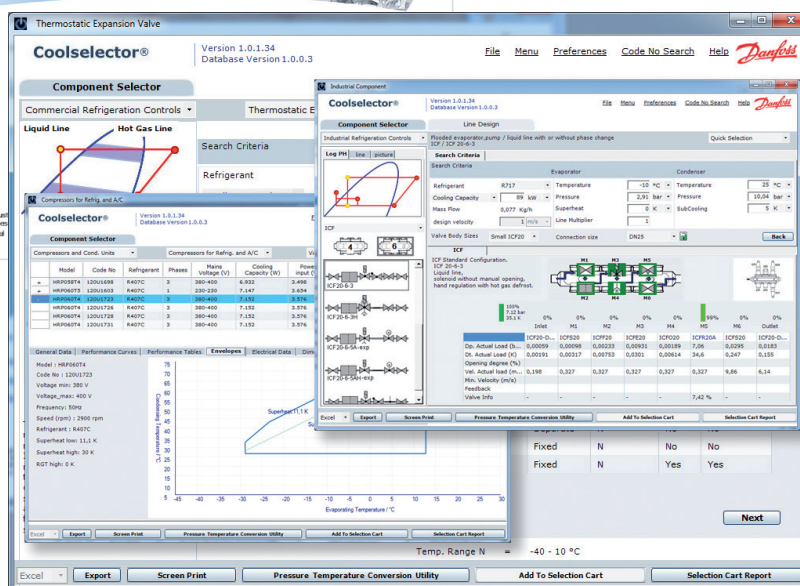

## Coolselector® – Select the right component the coolest way

As the world gets more complicated we all need support to make the right choices.

Danfoss helps you make the right selections also for the other components that you will need in your professional daily life. Coolselector® calculates for you the performance of the component at your conditions, not just according to the standards.

### Select the right component the coolest way

Do you pick your solenoid valve for your walk-in by connection size alone?

Maybe you could actually go for a size smaller, or maybe the cold room would have done better if you had optimized the selection of that particular valve to the flow. Most professionals know that selecting a thermostatic expansion valve can turn out to be a tricky task if the conditions are not exactly standard conditions. You will need to take superheat, sub cooling and pressure drop into consideration to find the optimal valve with the right orifice. But also other components require consideration before selecting the best valve for the purpose. Even the solenoid valve should be checked for the specific performance under the conditions you intend to expose it to.

Coolselector® helps you optimize the choice of component and even tells you how the component behaves at the conditions given.

With the new version of Coolselector® you have all the components required to control a commercial refrigeration plant. Danfoss have now included the well-known compressor and condensing unit selection program RS+3 in Coolselector® which means that you no longer have to open several programs to calculate a compressor, a solenoid valve and an expansion valve. You can now do this in just one program.

The new section with compressors and condensing units also includes compressors for heat pumps which mean that you easily can select the best suited compressor for heat pump applications. Danfoss has kept the familiar and user friendly interface from RS+3 and just extended the content in accordance with the additional compressors. Coolselector® will continue development and enhancement and offers you automatic-updates also in future. Please do not hesitate and go to the web address: [coolselector.danfoss.com](http://coolselector.danfoss.com) to download the program.

## Quick Select Guide

### Danfoss Learning - Your gateway to HVAC knowledge - anytime, from anywhere

Learn more about Danfoss' many energy saving and efficient products by accessing Danfoss Learning, a new online education platform packed with courses developed by experts. Open 24 hours a day.

As a user of Danfoss Learning you can choose between face-to-face courses at one of our training locations, step into a virtual classroom or even take self study courses of interest.

The many different training methods and offerings enable you to choose what to learn when it suits you.

Once on-line, you have immediate access to a wealth of learning offerings, all visible in your Personal Dashboard.

Here you have a clear overview of your in progress learning activities, and you can search for new courses and keep track of courses you have completed.

All our courses have been developed in accordance with best practice principles, by experienced trainers who know their field to the smallest detail. It is your guarantee that your time at Danfoss Learning is well spent.

Visit Danfoss Learning today and get started. It's fast, easy and you will quickly feel the effect of more knowledge in your daily work – and your bottom line.

[www.learning.danfoss.us](http://www.learning.danfoss.us)

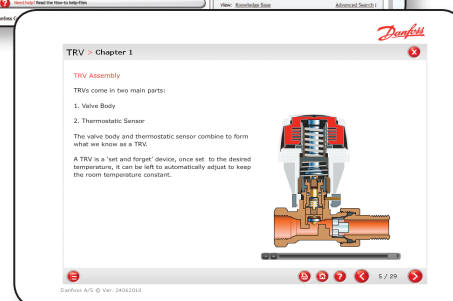
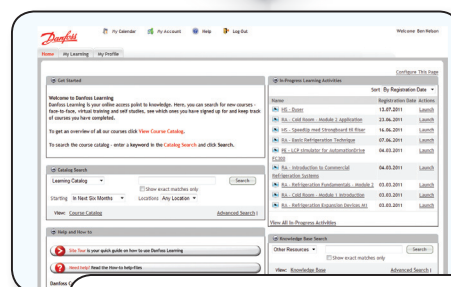

### Danfoss Videos and Smartphone Apps - a growing library of instructional tools

Visit Danfoss on YouTube™ and watch installation videos, product demonstrations and more from the comfort of your home or on the go on your smartphone.

Scan the QR code or visit:  
<http://www.youtube.com/user/DanfossGroup>



KoolApp™ is the new Danfoss App and features a library of several practical tools for the refrigeration professional on the go.

Scan the QR code or visit:  
[www.danfoss.com/koolapp](http://www.danfoss.com/koolapp)





<b>Contents</b>	<b>Page</b>
<b>Thermostatic Expansion Valves, Types TUA/TUAE</b>	
Introduction and Overview .....	7
Selection Instructions .....	8
Product Selection .....	9
<b>Thermostatic Expansion Valves, Type TR6</b>	
Introduction and Overview .....	10
Product Selection .....	11
<b>Thermostatic Expansion Valves, Type TGE</b>	
Introduction and Overview .....	12
Product Selection .....	13
<b>Pressure Controls, Type KPU</b>	
Introduction and Overview .....	14
Product Selection .....	15
Technical Data .....	16
<b>Temperature Controls, Type KPU</b>	
Introduction and Overview .....	17
Product Selection .....	18
Technical Data .....	18
<b>Solenoid Valves, Type EVR</b>	
Introduction and Overview .....	19
Product Selection .....	19
<b>Pressure Controlled Water Valves, Type WVFX</b>	
Introduction and Overview .....	20
Product Selection .....	21
<b>Pressure Regulators, Types KVP/KVL/KVR/NRD/KVC/CPCE</b>	
Introduction and Overview .....	22
Product Selection .....	23
<b>Filter Driers, Types DCL/DCB/DAS</b>	
Introduction and Overview .....	24
Nomenclature .....	24
Product Selection .....	25
<b>Ball Valves, Type GBC</b>	
Introduction and Overview .....	26
Product Selection .....	26
<b>Sight Glasses, Types SGN/SGRN</b>	
Introduction and Overview .....	27
Product Selection .....	27
<b>Light Commercial Compressors, Types BD/T/N/S</b>	
Introduction and Overview .....	28
Nomenclature .....	29
<b>Condensing Units, Type Optyma™</b>	
Introduction and Overview .....	30
Nomenclature /Model No. ....	30
Product Selection .....	31



<b>Reciprocating Compressors, Types MT/MTZ</b>	
Introduction and Overview .....	37
Nomenclature /Model No .....	37
Product Selection .....	38
<b>Reciprocating Compressors, Type NTZ</b>	
Introduction and Overview .....	39
Nomenclature /Model No .....	39
Product Selection .....	39
<b>Scroll Compressors, Types HRM/HLM/HCM/HRH/HLH/HLJ/HCJ</b>	
Introduction and Overview .....	40
Nomenclature /Model No .....	40
Product Selection .....	41
<b>Scroll Compressors, Types SM/SH</b>	
Introduction and Overview .....	43
Nomenclature /Model No .....	43
Product Selection .....	44
<b>Nominal Capacitor Values and Relays</b> .....	46
<b>Spare Parts and Accessories</b>	
Introduction and Overview .....	47

---

**Quick Select Guide**

---

**Introduction and Overview**

Danfoss TUA/TUAE are stainless steel (1) thermostatic expansion valves designed for use in a wide range of applications with several contractor friendly features built-in. The replaceable orifice (2) design permits easy sizing of the valve from 1/10 to 4 ½ tons and allows for easy access to the screen for cleaning. Bi-metal connections (3) of stainless steel and copper allow for fast, easy and cost-effective brazing – there is no need to wet wrap the valve.



The valve's body includes a laser-welded, non-replaceable steel power-head (4) which significantly reduces power-head failures and preserves the diaphragm's integrity, the primary cause of a failure. The capillary tube and sensing bulb (5) are made of stainless steel as it's tougher than copper and more resistant to breakage. TUA/TUAE valves include an adjustable superheat (6). Last, all identification information is laser engraved on the power-head for durable identification (7) – no paper labels.

Due to their small size, light weight and rapid installation time, TUA/TUA valves are particularly suited for new installations or when replacing a valve in a small space. Examples of typical applications include:



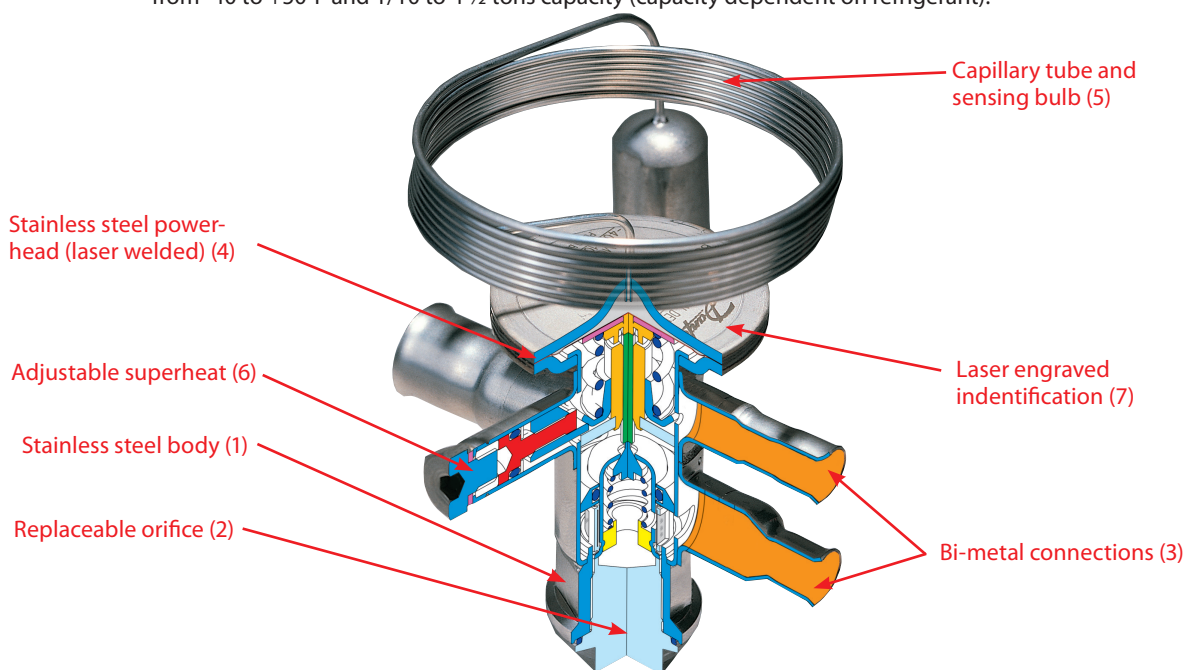

- Ice machines
- Single and multiple door refrigerators and freezers
- Walk-ins
- Glass door merchandisers
- Vending machines
- Display cases
- Air conditioning systems
- Transport refrigeration

By pairing one valve body with one of ten replaceable orifices, a contractor can satisfy applications from -40 to +50°F and 1/10 to 4 ½ tons capacity (capacity dependent on refrigerant).



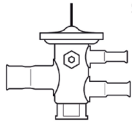

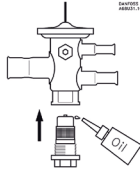
Selection Instrucions

<p><b>STEP 1 - SELECT VALVE BODY</b></p>	<ul style="list-style-type: none"> <li>Select one of six valve bodies based on refrigerant and equalization type using the "Valve Body Selection" section on the following page.</li> </ul>	
<p><b>STEP 2 - SELECT ORIFICE</b></p>	<ul style="list-style-type: none"> <li>Select one of ten orifices using the "Orifice Selection" section on the following page.</li> <li>Prior to installing into system, verify that only mesh portions of the screen cover the orifice inlet.</li> </ul>	
<p><b>STEP 3 - ASSEMBLE</b></p>	<ul style="list-style-type: none"> <li>Place one drop of oil between the screen cage and the pushpin.</li> <li>Verify that the metal gasket is seated on the base of the orifice.</li> <li>Torque the assembly to 19-22 ft-lb. In addition to eliminating leaks, proper torquing insures proper superheat control.</li> <li>Anytime an orifice is removed, the metal gasket should be replaced.</li> </ul>	
<p><b>STEP 4 - BRAZE</b> <b>NO WET WRAP REQUIRED!</b></p>	<ul style="list-style-type: none"> <li>Clean and insert copper tubing into appropriate connection on valve.</li> <li>Direct torch at copper tubing until it begins to color (10-15 seconds).</li> <li>Briefly direct torch on valve connection (2-5 seconds).</li> <li>Apply brazing alloy until it flows. Do not try to fill the ridge - attempts to do so may clog the connector.</li> <li>Sweat connections using any common brazing alloy (6-15% silver). As internal connector surface is copper, connections are copper to copper, and there is no need for use of high silver content solder.</li> </ul>	
<p><b>STEP 5 - ADJUST SUPER-HEAT</b></p>	<ul style="list-style-type: none"> <li>Remove the cap with a 5/32 in. Allen wrench.</li> <li>Make superheat adjustments ¼ turn at a time (¼ turn≈1°F). Turning clockwise increases superheat. Turning counter-clockwise decreases superheat.</li> <li>Reinstall the cap.</li> <li>TXVs on low temperature systems may require more adjustment as the factory setting is for medium temperature systems</li> </ul>	

## Quick Select Guide

## Thermostatic Expansion Valves, Types TUA/TUAE

### Product Selection

#### 1. Valve Body Selection

Select the valve body based on refrigerant and need for internal or external equalization using the table below.

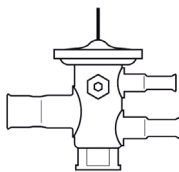

Equalization	R-22	R-404A	R-134a
Internal	068U2235	068U2285	068U2205
External	068U2237	068U2287	068U2207

All valves have  $\frac{3}{8}$  x  $\frac{1}{2}$  ODF connections, with MOP and are range N (-40°F to 50°F). Other variations and refrigerants available upon request.

#### 2. Orifice Selection

TUA/TUAE valve capacities are based on the installed orifice. To select the correct size, use one of the two methods below:

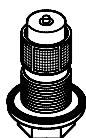

**System characteristics:** Select the orifice using appropriate refrigerant, evaporator temperature, and system capacity using charts to the right.

OR

**Competitor crossover:** Use the nominal capacity of the competitor valve (capacity used in competitor part number) and match with nominal capacity in chart below.

#### Nominal Capacities for Competitor Cross Reference

Orifice Size	Danfoss Code No.	R-22	R-404A	R-134a
		Rated Capacity in Tons <sup>1</sup>		
0	068U1030	1/5	1/8	1/8
1	068U1031	1/4	1/5	1/5
2	068U1032	1/3	1/4	1/4
3	068U1033	1/2	1/3	1/3
4	068U1034	3/4	1/2	1/2
5	068U1035	1	3/4	3/4
6	068U1036	1 1/2	1	1
7	068U1037	2	1 1/2	1 1/2
8	068U1038	3	2 1/4	2
9	068U1039	4 1/2	3 1/2	3

<sup>1</sup>Nominal capacity based on condensing temperature of 90°F, a vapor free liquid temperature of 80°F ahead of the expansion valve, and an evaporator temperature of 40°F.

#### TUA/E Kits - Easy to carry kit for truck stock

All valve bodies and orifices featured on this page	000MMK-U
Empty kit - Select valve bodies and orifices separately	000MMK-S

Other kits available for flare connections

<sup>2</sup>Capacities based on 90°F condensing temperature and 80°F vapor free liquid temperature ahead of TXV. For systems operating significantly outside the range, please size using Danfoss TUA Technical Brochure (Danfoss Lit. No. DKRCC.PD. AG0.A2.22) or contact Danfoss Application Engineering for more information.

IF EXACT CAPACITY IS NOT FOUND, USE NEXT LARGER ORIFICE									
R-22		Evaporator Temperature (°F)							
Orifice Size	Danfoss Code No.	45	35	25	0	-10	-20	-30	-40
		Rated Capacity in Tons <sup>2</sup>							
0	068U1030	1/6	1/6	1/6	1/8	1/8	1/10	1/10	1/10
1	068U1031	1/4	1/4	1/4	1/8	1/6	1/8	1/8	1/10
2	068U1032	1/3	1/4	1/4	1/5	1/6	1/6	1/8	1/8
3	068U1033	1/2	1/3	1/3	1/3	1/4	1/4	1/6	1/6
4	068U1034	3/4	1/2	1/2	1/2	1/3	1/3	1/4	1/4
5	068U1035	1	3/4	3/4	1/2	1/2	1/2	1/3	1/3
6	068U1036	1 1/2	1	1	3/4	3/4	3/4	1/2	1/2
7	068U1037	2	1 1/2	1 1/2	1	1	1	3/4	3/4
8	068U1038	3	2 1/2	2 1/2	2	1 3/4	1 1/2	1 1/4	1
9	068U1039	4 1/2	4 1/4	4	3	2 1/2	2	1 3/4	1 1/2
R-134a		Evaporator Temperature (°F)							
Orifice Size	Danfoss Code No.	45	35	25	0	-10	-20	-30	-40
		Rated Capacity in Tons <sup>2</sup>							
0	068U1030	1/8	1/8	1/10	1/10	1/10	1/15	1/15	1/20
1	068U1031	1/6	1/5	1/6	1/8	1/10	1/15	1/15	1/20
2	068U1032	1/4	1/4	1/5	1/8	1/8	1/10	1/15	1/15
3	068U1033	1/3	1/3	1/4	1/6	1/6	1/8	1/10	1/10
4	068U1034	1/2	1/2	1/2	1/3	1/4	1/6	1/6	1/8
5	068U1035	3/4	3/4	1/2	1/3	1/3	1/4	1/4	1/6
6	068U1036	1 1/4	1	1	1/2	1/2	1/3	1/3	1/4
7	068U1037	1 1/2	1 1/3	1 1/4	3/4	3/4	1/2	1/2	1/3
8	068U1038	2 1/3	2	2	1 1/3	1	3/4	3/4	1/2
9	068U1039	3 1/2	3 1/4	3	2	1 1/2	1 1/3	1	3/4
R-404A		Evaporator Temperature (°F)							
Orifice Size	Danfoss Code No.	45	35	25	0	-10	-20	-30	-40
		Rated Capacity in Tons <sup>2</sup>							
0	068U1030	1/8	1/8	1/10	1/10	1/10	1/15	1/15	1/20
1	068U1031	1/6	1/6	1/6	1/8	1/8	1/10	1/15	1/15
2	068U1032	1/4	1/4	1/4	1/6	1/8	1/8	1/10	1/10
3	068U1033	1/3	1/3	1/3	1/4	1/6	1/6	1/8	1/8
4	068U1034	1/2	1/2	1/2	1/3	1/3	1/4	1/5	1/6
5	068U1035	3/4	3/4	1/2	1/2	1/3	1/3	1/4	1/4
6	068U1036	1	1	1	3/4	1/2	1/2	1/3	1/3
7	068U1037	1 1/2	1 1/2	1 1/3	1	3/4	3/4	1/2	1/2
8	068U1038	2 1/2	2 1/4	2	1 1/2	1 1/3	1	1	3/4
9	068U1039	3 1/2	3 1/3	3	2 1/4	2	1 1/2	1 1/3	1

**Introduction and Overview**

TR6 thermostatic expansion valves have been designed and developed with features especially for use in applications such as:

- Residential air conditioning systems
- Split systems
- Roof top units
- Heat pumps
- Light commercial air conditioning systems
- Chillers

The hermetic tight design meets environmental demands for today and the future. The TR6 valves are available for R-22 and R-410A systems. The TR6 design incorporates a hot-pressed brass body with the entire laser-welded power element (1), including the 31 1/2" capillary tube (2) and sensing bulb with anti-hunt charge (3) which is fabricated from stainless steel. The valves are supplied standard with straightway 3/8" x 3/8" ODF connections, fixed orifice and with 24" external equalization line and 1/4" flare fitting (4). The aftermarket versions are delivered with internal check valve (5) and with external superheat adjustment spindle (6) for field retrofit.

All valves are of a balanced port design which reduces the influence from varying condensing pressures. The TR6 valves listed below are delivered with Aeroquip and Chatleff fittings for evaporator connections, insulating tape, a bulb strap and instructions for easy installation in the field.

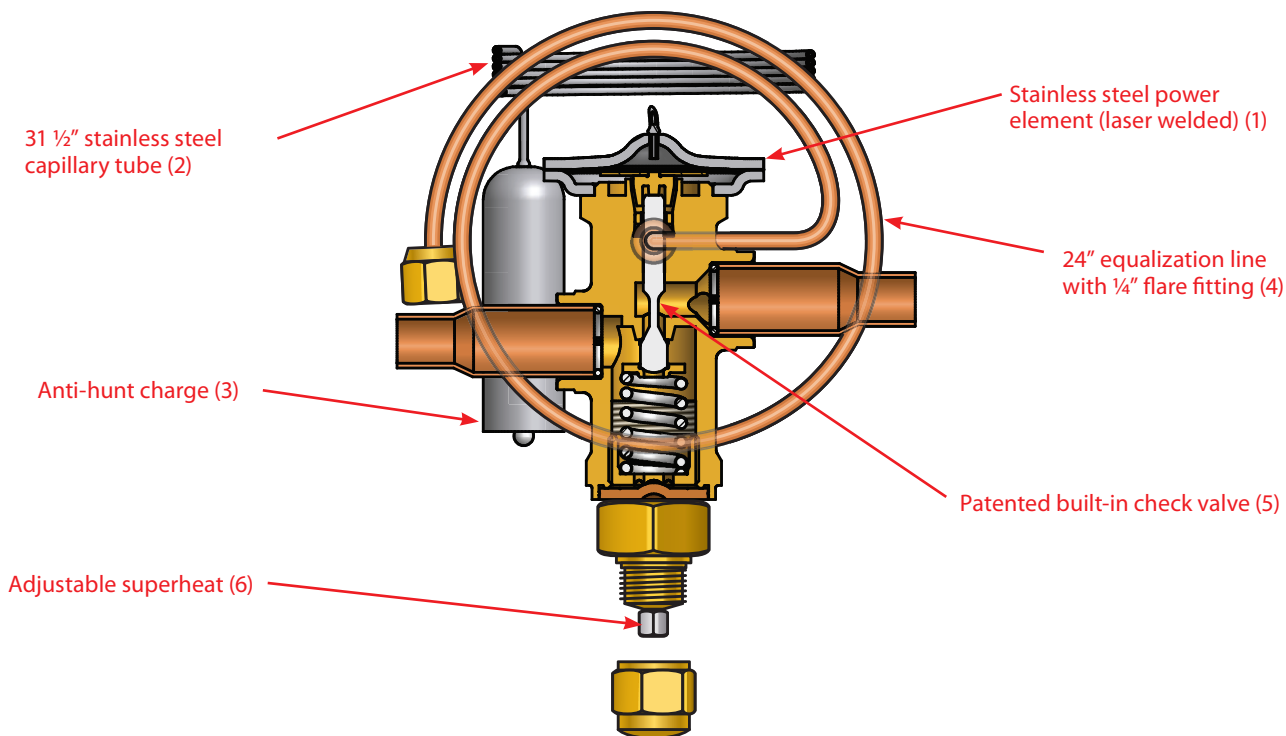



Product Selection

Select valve using system capacity and refrigerant.

Refrigerant	System Capacity (tons)	Connection (in.)	Weight (lbs)	Danfoss Code No. <sup>1</sup>	Danfoss Minimizer Kit Code No.		
R-410A	1 1/2 - 3	3/8 x 3/8	0.67	067L5955	TR6-MMK4		
	3 1/2 - 4			067L5956			
	4 1/2 - 5			067L5957			
R-22	1 1/2 - 2			3/8 x 3/8	0.67	067L5856	TR6-MMK2
	2 1/2 - 3					067L5857	
	3 1/2 - 4					067L5858	
	5 - 6	067L5859					

<sup>1</sup>TR6 valves included table above are standard aftermarket valves and are supplied with an adjustable superheat setting.

**Always have the TXV you need on hand!**

Danfoss offers two convenient minimizer kits that contain all of the TXV's listed above. See Code Nos. listed in table above.



**Introduction and Overview**

TGE is a series of thermostatic expansion valves for R-22/R-407C, R-134a, R-404A and R-410A with fixed orifice. The hermetic tight design meets the environmental demands for today and future in a wide range of applications that include:

- Commercial air conditioning systems
- Heat pumps
- Chillers
- Transport refrigeration
- Other refrigeration systems

Additional features include:

- Stainless steel capillary tube and bulb (1)
- Laser welded stainless steel power element (2)
- No machining of thrust pad (3)
- 2-way balance port (4)
- Easy adjustment of superheat (5) with protective cap (6)
- Head pressure independent adjacent to 2-way balance port
- MAH (Maximum Operating Pressure Anti-Hunt) charge standard for R-22/R-407C and R-410A
- N charge standard for R-134a and R-404A
- Straight-way flow
- Maximum working pressure: 667 psi

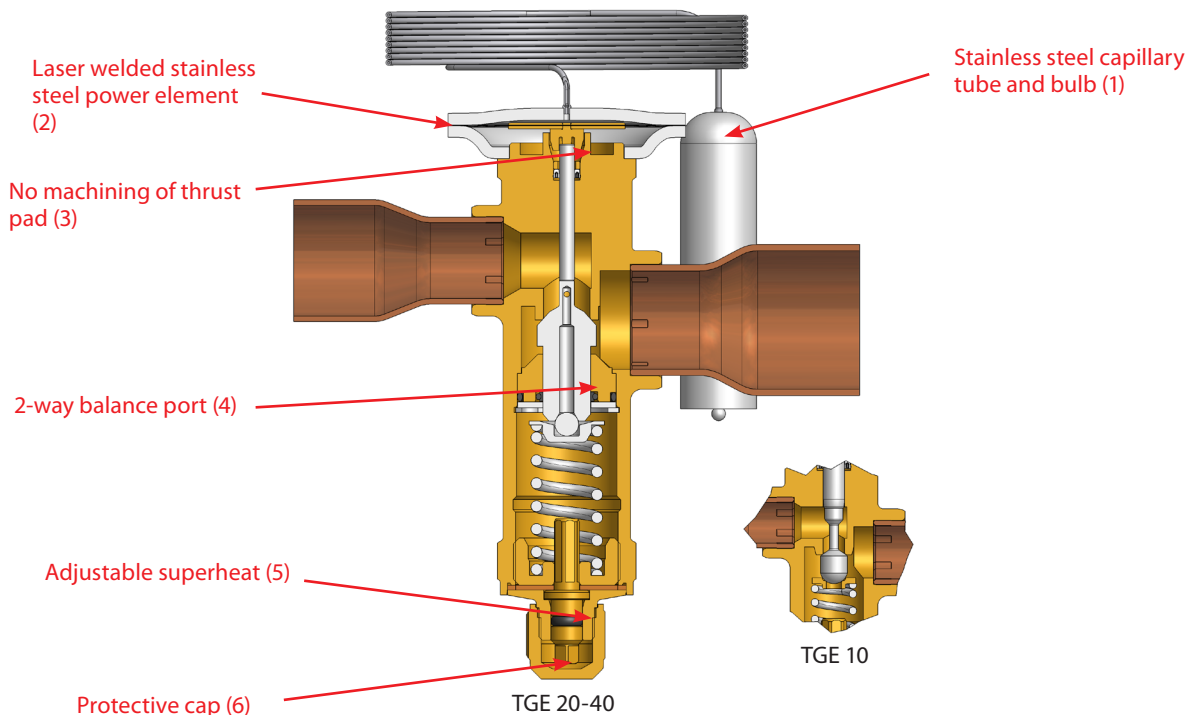

**Product Selection**

Model No.	Competitor Model Nos.	Nominal capacity (tons) <sup>3</sup>	Connection (in.)	Weight (lbs)	Code No.	
<b>R-22/R-407C, MAH charge <sup>1</sup></b>						
TGEX/Z 6/5	SVE-5, EVRE-5	HFES-5H	6	1/2 x 5/8	0.81	<b>067N9403</b>
TGEX/Z 6/5			6	1/2 x 7/8	0.81	<b>067N9404</b>
TGEX/Z 7.5/7	SVE-6, EVRE-6		7.5	5/8 x 7/8	0.81	<b>067N9406</b>
TGEX/Z 7.5/7			7.5	5/8 x 1 1/8	0.81	<b>067N9483</b>
TGEX/Z 11/10	SVE-8, SVE-10, EBSVE 8, EVRE 8, EVRE 10	HFES-8H, HFES-10H, TRAE-10H	11	5/8 x 7/8	0.81	<b>067N9407</b>
TGEX/Z 12/12.5	EBSVE 11, EVRE 12		12	5/8 x 7/8	1.27	<b>067N9409</b>
TGEX/Z 15/16	EBSVE15, OVE 15	HFES-15H, TRAE-15H	15	5/8 x 1 1/8	1.27	<b>067N9411</b>
TGEX/Z 15/16			15	7/8 x 1 1/8	1.27	<b>067N9412</b>
TGEX/Z 18/20			18	7/8 x 1 1/8	1.27	<b>067N9413</b>
TGEX/Z 26/26	EBSVE 20, OVE 20	HFES-20H, TRAE 20H	26	7/8 x 1 3/8	2.05	<b>067N9415</b>
TGEX/Z 30/30	OVE 30	TRAE 30H	30	1 1/8 x 1 3/8	2.05	<b>067N9418</b>
TGEX/Z 38/34	OVE 40	TRAE 40H	38	1 1/8 x 1 3/8	2.05	<b>067N9419</b>
<b>R-410A, MAH charge <sup>1</sup></b>						
TGEL 9	ERZE-8		9	5/8 x 7/8	0.81	<b>067N9206</b>
TGEL 13	ERZE-12.5	TFES-12Z	13	5/8 x 7/8	0.81	<b>067N9207</b>
TGEL 15	ERZE-15	TFES-16Z	15	5/8 x 7/8	1.27	<b>067N9209</b>
TGEL 15			15	5/8 x 1 1/8	1.27	<b>067N9210</b>
TGEL 23	OZE-20		23	7/8 x 1 1/8	1.27	<b>067N9213</b>
TGEL 23			23	1 1/8 x 1 1/8	1.27	<b>067N9284</b>
TGEL 31	OZE-25		31	7/8 x 1 1/8	2.05	<b>067N9285</b>
TGEL 31			31	7/8 x 1 3/8	2.05	<b>067N9215</b>
TGEL 35	OZE-35		35	1 1/8 x 1 3/8	2.05	<b>067N9218</b>
TGEL 46			46	1 1/8 x 1 3/8	2.05	<b>067N9219</b>
<b>R-134a, N charge <sup>2</sup></b>						
TGEN 7	SJE-5, SJE-6, EBSJE-5	HFES-6M	7	5/8 x 1 1/8	0.81	<b>067N5158</b>
TGEN 8	EBSJE-7	HFES-7.5M	8	5/8 x 7/8	1.27	<b>067N5159</b>
TGEN 12	EBSJE-12, OJE-12	HFES-11M	12	7/8 x 1 1/8	1.27	<b>067N5163</b>
TGEN 17	OJE-16	HFES-14M, TRAE-13M, TRAE-14M	17	1 1/8 x 1 1/8	2.05	<b>067N5254</b>
TGEN 20			20	1 1/8 x 1 1/8	2.05	<b>067N5255</b>
TGEN 25	OJE-23	TRAE-22M	25	1 1/8 x 1 3/8	2.05	<b>067N5169</b>
<b>R-404A, N charge <sup>2</sup></b>						
TGES 4	SSE-3	HFES-3.5S	4	1/2 x 7/8	0.81	<b>067N6151</b>
TGES 5	SSE-4	HFES-5S	5	1/2 x 7/8	0.81	<b>067N6166</b>
TGES 5			5	5/8 x 7/8	0.81	<b>067N6150</b>
TGES 7.5	SSE-6, SSE-7, EBSSE-6	HFES-7S	7.5	5/8 x 7/8	0.81	<b>067N6154</b>
TGES 9	EBSSE-7.5	TRAE-8S	9	5/8 x 7/8	1.27	<b>067N6158</b>
TGES11	EBSSE-10, OSE-9	HFES-10S	11	5/8 x 7/8	1.27	<b>067N6188</b>
TGES 11			11	5/8 x 1 1/8	1.27	<b>067N6155</b>
TGES 11			11	7/8 x 1 1/8	1.27	<b>067N6181</b>
TGES 13	EBSSE-13, OSE-12	HFES-13S, TRAE-12S	13	7/8 x 1 1/8	1.27	<b>067N6162</b>
TGES 21	OSE-21	TRAE-20S	21	1 1/8 x 1 3/8	2.05	<b>067N6186</b>

<sup>1</sup> Maximum Operating Pressure Anti-Hunt -22 to +59°F, Maximum operating temperature: 302°F for Air Conditioning applications

<sup>2</sup> N charge -40 to +50°F, Maximum operating temperature: 210°F for refrigeration applications

Maximum working pressure: 667 psig, Maximum test pressure: 740 psig,

<sup>3</sup> Nominal capacity based on ARI standard, Evaporating temperature: 40°F, Liquid temperature: 98°F

Condensing temperature: 100°F



**Introduction and Overview**

KPU pressure controls are designed for use in refrigeration and air-conditioning systems to protect the systems from excessively low suction pressure or too high discharge pressure. They can also be applied to start and stop compressors and the fans of air-cooled condensers. KPU pressure controls, in single and dual versions cover a comprehensive range of applications and are designed for use with fluorinated and non-aggressive refrigerants. Most KPU pressure controls can be used on R-410A systems.

Danfoss KPU pressure controls are specifically designed for the North American aftermarket. These products are designed with a universal bolt pattern, snap-action switch (1), easy to access and maintain contacts with 24 FLA rating (2), high visibility, high contrast scale (3), "finger tip" test for contact operation (4), easy access wiring. Danfoss KPU 6 and high pressure side of KPU 16 are designed with fail-safe double bellows design (5) – assuring no loss of refrigerant even if a bellows ruptures. KPU pressure controls function as easy and direct replacements for most competitor controls. Other features include:



- Pressure connection available as 1/4" M flare or with 36" capillary tube (6)
- Easy adjustment of pressure and differential setting with standard refrigeration wrench - a set screw prevents settings from migrating (7)
- Automatic, manual or convertible reset versions available

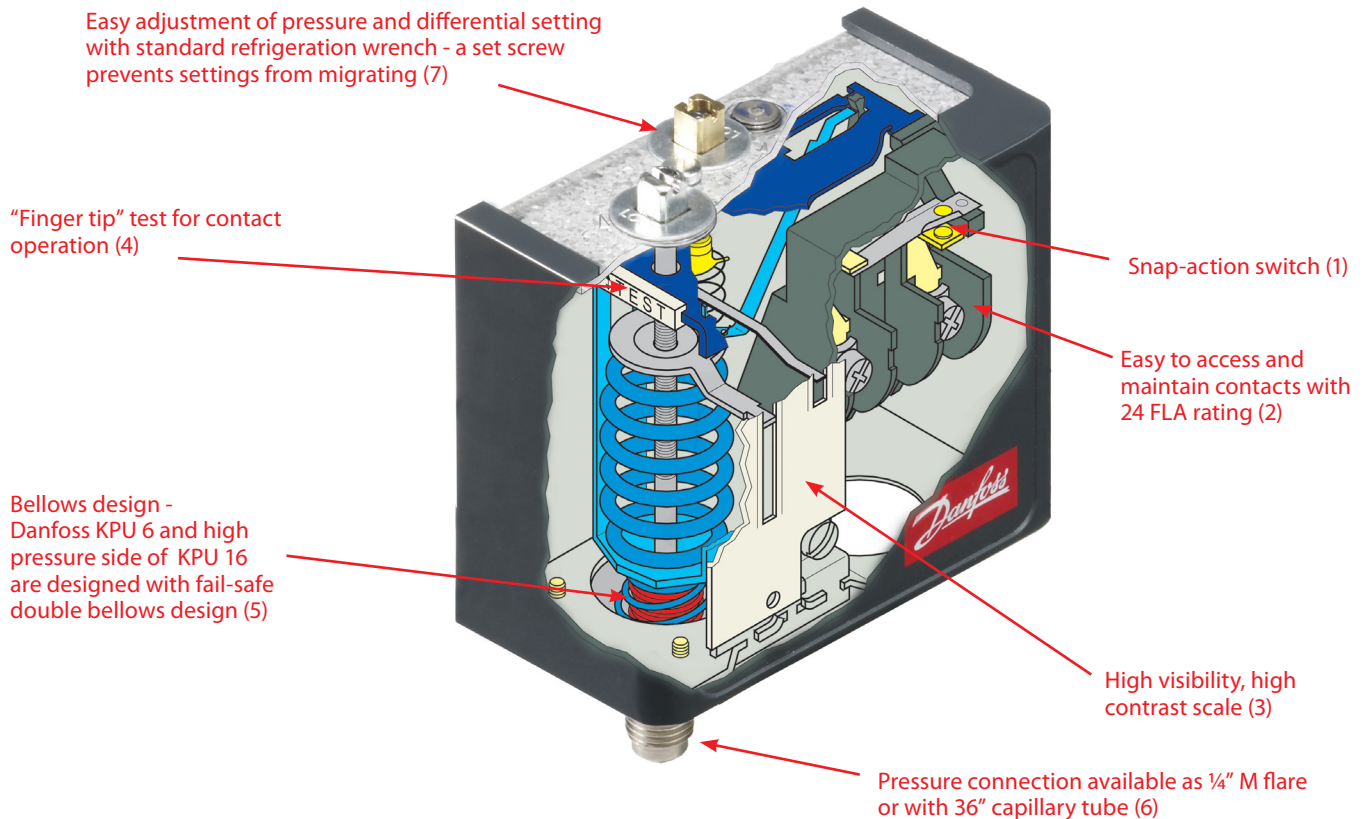

## Quick Select Guide Pressure Controls, Type KPU

### Product Selection

#### Low Pressure, High Pressure, and Fan Cycling Controls

Pressure	Type	Competitor Part No. <sup>1</sup>	Danfoss Code No.				Reset	Contact System	Range (psig)	Differential (psi)	Refrigerant
			1/4" M flare	Weight (lbs)	3/6" capillary tube with 1/4" flare nut	Weight (lbs)					
Low	KPU 1	O10-1483	<b>060-5231</b>	0.765	<b>060-5233</b>	0.91	Automatic	SPDT	6 to 108	10 to 60	HCFC and HFC
Low	KPU 1		<b>060-5236</b>	0.765			Automatic	SPST	6 to 108	10 to 60	
Low	KPU 2	O10-1402	<b>060-5237</b>	0.765	<b>060-5235</b>	0.91	Automatic	SPST	6 to 73	6 to 30	
Low	KPU 2		<b>060-5239</b>	0.765	<b>060-5240</b>	0.91	Automatic	SPDT	6 to 73	6 to 30	
Low	KPU 1B	P70AB12 P70AB2	<b>060-5232</b>	0.765	<b>060-5234</b>	0.91	Manual	SPDT	28 to 100	10	
Fan cycling	KPU 5	O10-2054 P70AA118	<b>060-5241</b>	0.765	<b>060-5242</b>	0.91	Automatic	SPST	100 to 465	25 to 85	
High	KPU 6W	O16-108	<b>060-5243</b>	0.765	<b>060-5245</b>	0.91	Automatic	SPDT	100 to 600	58 to 145	
High	KPU 6B		<b>060-5244</b>	0.765	<b>060-5246</b>	0.91	Manual	SPDT	100 to 600	60	

#### Dual Pressure Controls

Type	Competitor Part No. <sup>1</sup>	Danfoss Code No.				Low pressure side		High pressure side		Reset		Contact system	Refrigerant
		1/4" M flare	Weight (lbs)	3/6" capillary tube	Weight (lbs)	Range (psig)	Differential (psi)	Range (psig)	Differential (psi)	Low pressure side	High pressure side		
KPU 15	O12-1549	<b>060-5247</b>	1.19	<b>060-5248</b>	1.5	6 to 108	10 to 60	100 to 465	60	Automatic	Automatic	SPST dual pressure (LP/HP)	HCFC and HFC
KPU 15B	P170LB1 <sup>2</sup> P70LB1 P70MA1	<b>060-5249</b>	1.19	<b>060-5250</b>	1.5	6 to 108	10 to 60	100 to 465	60	Automatic	Manual	SPST dual pressure (LP/HP)	
KPU 16W		<b>060-5251</b>	1.19	<b>060-5252</b>	1.5	6 to 108	10 to 60	100 to 600	60	Automatic	Automatic	SPDT LP/HP signal	
KPU 16B	O12-4834	<b>060-5253</b>	1.19	<b>060-5254</b>	1.5	6 to 108	10 to 60	100 to 600	60	Convertible <sup>2</sup>	Convertible <sup>2</sup>	SPDT LP/HP signal	

<sup>1</sup> Competitor Part No. equipped with capillary tube for all but P170LB1<sup>2</sup> which has flare connection.

<sup>2</sup> Convertible reset controls can be adjusted for either automatic or manual reset.

**All controls are supplied with universal mounting bracket and mounting screws.**

**Technical Data**
**Contact Load**

<b>120/240 VAC</b>	
Alternating Current	
Motor Full Load Amps (FLA)	24
Locked Rotor Amps (LRA)	144
Direct Current	240 V DC: 12W pilot duty

**Single Pressure Controls - Pressure and Temp Ratings**

Type	Maximum working pressure (psig)	Maximum testing pressure (psig)	Ambient temperature (°F)
KPU 1, 2	250	290	-40 to 122 (170 for maximum 2 hours)
KPU 5	510	530	
KPU 6 <sup>3</sup>	675	725	

**Dual Pressure Controls - Pressure and Temp Ratings**

Type	Maximum working pressure (psig)		Maximum testing pressure (psig)		Ambient temperature (°F)
	Low pressure side	High pressure side	Low pressure side	High pressure side	
KPU 15	250	510	290	530	-40 to 122 (170 for maximum 2 hours)
KPU 16 <sup>3</sup>		675		725	

<sup>3</sup>High pressure side has double bellows for safety and to minimize risk of losing charge.



**Introduction and Overview**

KPU temperature controls are temperature controlled electrical switches, which are applied for regulation and safety monitoring of refrigeration and air conditioning systems. KPU controls are available with vapor charge or with adsorption charge. Temperature controls with adsorption charge are widely used to give frost protection, while vapor charged sensors are used where small differential is required. All KPU temperature controls have a single pole double throw (SPDT) contact system. The position of the switch depends on the thermostat setting and the bulb temperature.



KPU temperature controls function as easy and direct replacements for most competitor controls. Like the KPU pressure controls, Danfoss KPU temperature controls are specifically designed for the North American aftermarket with similar features and benefits. Some of the features include:

- Easy adjustment of pressure setting with hand knob (all but models with manual reset). Differential setting adjusted with standard refrigeration wrench. A set screw prevents settings from migrating. (1)
- “Finger tip” test for contact operation (2)
- Bellows design (3)
- Switch with snap-action function (4)
- Easy to access and maintain contacts with 24 FLA rating (5)
- High visibility, high contrast scale (6)
- Bulb types available include: straight capillary tube, remote air coil, room sensor, double contact remote bulb, remote bulb and remote duct coil (7)

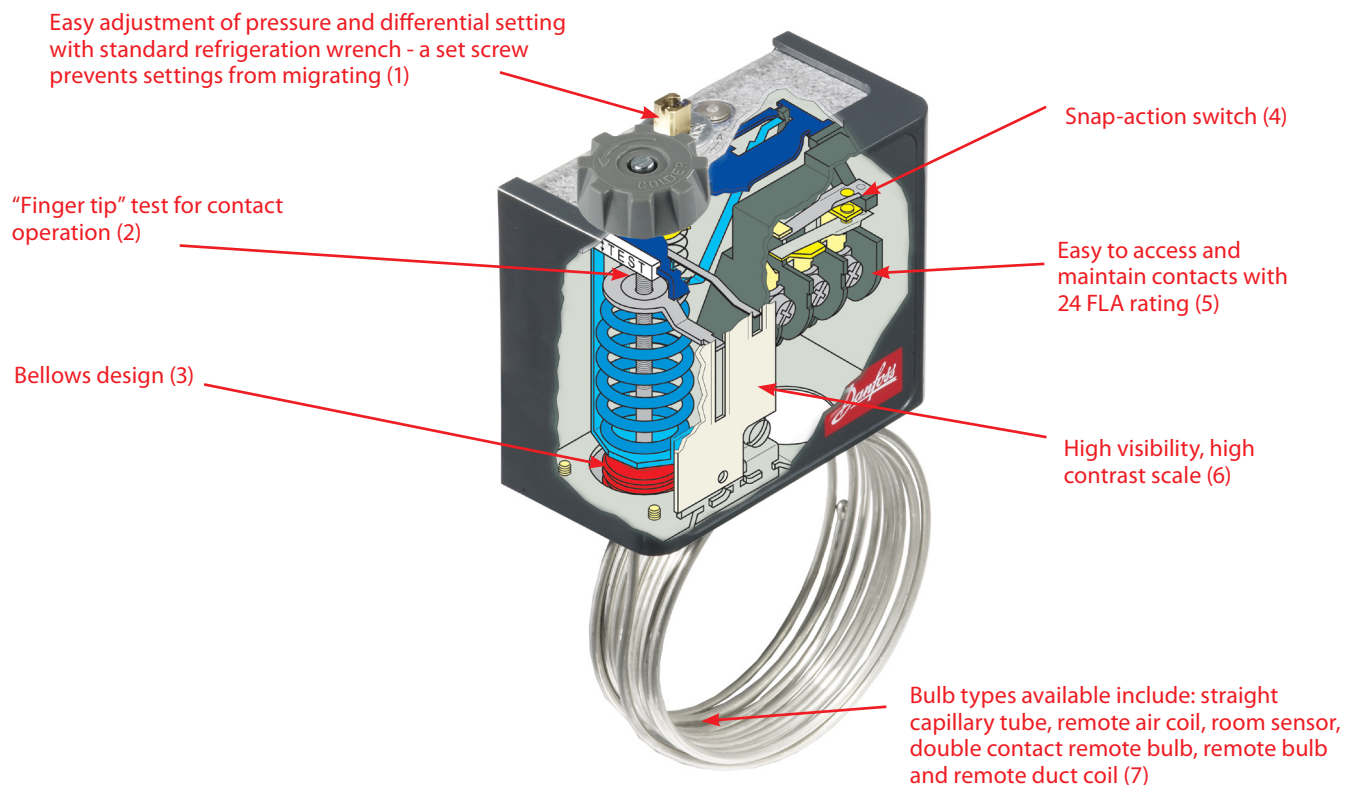

## Quick Select Guide Temperature Controls, Type KPU

### Product Selection

Charge	Type	Competitor Part No.	Danfoss Code No.	Weight (lbs)	Bulb type	Capillary tube length (in.)	Reset	Range (°F)	Differential		Maximum bulb temperature (°F)	Maximum ambient temperature (°F)
									at lowest temperature setting	at highest temperature setting		
Vapor <sup>1</sup>	KPU 61		<b>060L5201</b>	0.94	Straight capillary tube	80	Automatic	-20 to 60	8 to 40	2.5 to 13	250	-40 to 122 (170 for maximum 2 hours)
	KPU 61		<b>060L5203</b>	0.94	Remote air coil	80	Automatic	-20 to 60	8 to 40	2.5 to 13		
	KPU 61B		<b>060L5204</b>	0.94	Remote air coil	80	Manual <sup>3</sup>	-20 to 60	fixed 10	fixed 3.5		
	KPU 61B		<b>060L5205</b>	1.2	Remote air coil	200	Manual <sup>3</sup>	-20 to 60	fixed 10	fixed 3.5		
	KPU 62	A19BBC2 O10-1072 O60-1418	<b>060L5206</b>	0.77	Room sensor	Room sensor	Automatic	-20 to 60	8 to 40	2.5 to 13		
	KPU 61		<b>060L5210</b>	0.94	Remote air coil	80	Automatic <sup>4</sup>	-20 to 60	8 to 40	2.5 to 13		
	KPU 63		<b>060L5213</b>	0.94	Straight capillary tube	80	Automatic	-60 to 15	18 to 125	5 to 15		
	KPU 63		<b>060L5214</b>	0.94	Remote air coil	80	Automatic	-60 to 15	18 to 125	5 to 15		
	KPU 68		<b>060L5215</b>	0.77	Room sensor	Room sensor	Automatic	25 to 95	8 to 45	3 to 13		
	KPU 69		<b>060L5217</b>	0.94	Remote air coil	80	Automatic	25 to 95	8 to 45	3 to 13		
Adsorption <sup>2</sup>	KPU 73	A19ABA40 A18ABC24 O10-1408 O10-1409	<b>060L5208</b>	0.94	Remote bulb	80	Automatic	-15 to 60	6 to 18	5 to 50	175	
	KPU 73		<b>060L5209</b>	0.94	Remote bulb	80	Automatic	-15 to 60	22 to 125	15 to 45		
	KPU 73B		<b>060L5211</b>	0.94	Remote bulb	80	Manual <sup>3</sup>	-15 to 60	fixed 6	fixed 6		
	KPU 73		<b>060L5212</b>	0.94	Double contact remote bulb	80	Automatic	-15 to 60	6 to 35	5 to 32		
	KPU 71		<b>060L5218</b>	0.94	Remote bulb	80	Automatic	25 to 70	5.5 to 18	4 to 16		
	KPU 71B		<b>060L5216</b>	0.94	Remote bulb	80	Manual <sup>3</sup>	25 to 70	fixed 5	fixed 5		
	KPU 74		<b>060L5219</b>	0.94	Remote bulb	80	Automatic	0 to 80	9 to 35	9 to 35		
	KPU 75		<b>060L5221</b>	0.94	Remote duct coil	80	Automatic	30 to 95	6 to 29	4.5 to 21.5		
	KPU 77		<b>060L5223</b>	0.94	Remote bulb	80	Automatic	60 to 140	6 to 18	6.3 to 18	265	

<sup>1</sup> Bulb must be installed in colder position than thermostat housing and capillary tube

<sup>2</sup> Bulb can be placed warmer or colder than thermostat housing and capillary tube, but variations from + 70 °F ambient temperature will influence the scale accuracy.

<sup>3</sup> Manual minimum reset. Marked with letter B. Fixed differential. These controls have no hand knob.

<sup>4</sup> With manual switch and top plate.

**All controls are supplied with universal mounting bracket and mounting screws.**

### Technical Data Contact Load

	120/240 V AC
Alternating Current	
Motor Full Load Amperes (FLA)	24
Motor Locked Rotor Amps (LRA)	144
Direct Current	240V DC: 12W pilot duty

**Introduction and Overview**

Danfoss offers a complete and flexible range of solenoid valves for use in refrigeration and A/C systems. EVR solenoid valves are direct or servo-operated solenoid valves for liquid, suction and hot gas lines. Direct-operated versions for low capacity applications and tubing sizes of 3/8" or smaller or servo-operated valves for larger flows are available. They are suitable for all refrigeration, freezing and air conditioning applications and are compatible with fluorinated refrigerants. Versions for high-pressure refrigerants are available by contacting Danfoss. The valves can be delivered as normally open and normally closed as well as with or without manual operation. Additionally, they have the following features:

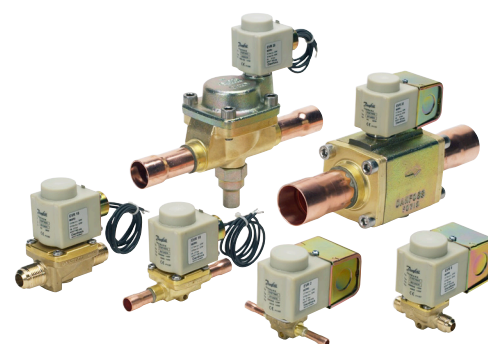

- Wide range of coils for AC and DC voltages
- Temperature range from -40° to 220°F
- Flare connections up to 5/8"
- Solder connections up to 2 1/8"
- Solder versions have extended connections; no need to dismantle valve when soldering

**Product Selection**

Type	Rated capacity R-22 (liquid)	Connection (in.)	Port size (in.)	Flow Coefficient, C <sub>v</sub> value (gal/min)	Weight (without coil) (lbs)	Code No. * solder ODF	
						with manual stem	without manual stem
EVR 3	2.03	1/4	1/8	0.32	0.3		032F7105
EVR 3	2.03	3/8	1/8	0.32	0.3		032F1157
EVR 6	5.83	3/8	15/64	0.93	0.4	032F7116	032F7115
EVR 6	5.83	1/2	15/64	0.93	0.4	032F7144	032F1162
EVR 8	8.01	1/2	5/16	1.3	0.4	032F7148	032F7121
EVR 10	13.8	5/8	3/8	2.2	0.8	032F7149	032F1168
EVR 15	18.9	5/8	9/16	3	1.4		032F1171
EVR 18	24.6	7/8	19/32	3.9	1.4	032F1004	
EVR 20	36.4	7/8	7/8	5.8	2.4	032F1177	032F1176
EVR 22	43.7	1 1/8	15/16	6.9	2.4	032F7137	032F7145
EVR 25	72.8	1 3/8	1	12	6.7	032F1194	032F1193
EVR 32	116.5	1 5/8	7/8	18	8.5	042H1179	042H1178

\* Valve body excluding coil. Additional Code Nos. available in Coolselector or contact Danfoss.

**Coils**

Voltage (V)	Frequency (Hz)	Weight (lbs)	Code No.		Power consumption
			Junction Box NEMA 2	Conduit Boss NEMA 4	
24	50/60	1	018F7683	018F7693	Holding: 14W 28VA Inrush: 49VA
110	50/60		018F7682	018F7692	
120	60				
208-240	60				
230	50		018F7681	018F7691	

**Introduction and Overview**

WVFX pressure controller water regulating valves are used to regulate the flow of water in a refrigeration plant with water-cooled condensers. Water valves regulate water flow thereby controlling and maintaining constant condensing pressure. At shut-down, cooling water flow is shut off automatically. The WVFX valves are designed as wide-range, general purpose valves. Additional features include:

- Complete flow range – 1.6 to 6.4 gal/min
- Knob for easy adjustment of pressure on WVFX valves (1)
- NPT threads – 3/8" to 1" for water side connection (2)
- 1/4" M flare or 1/4" F flare nut with capillary tube for condenser side connection (3)
- For HCFC and HFC refrigerants
- Needs no power – self acting
- Versions with capillary tubes available
- Opens on rising condensing pressure
- Insensitive to dirt

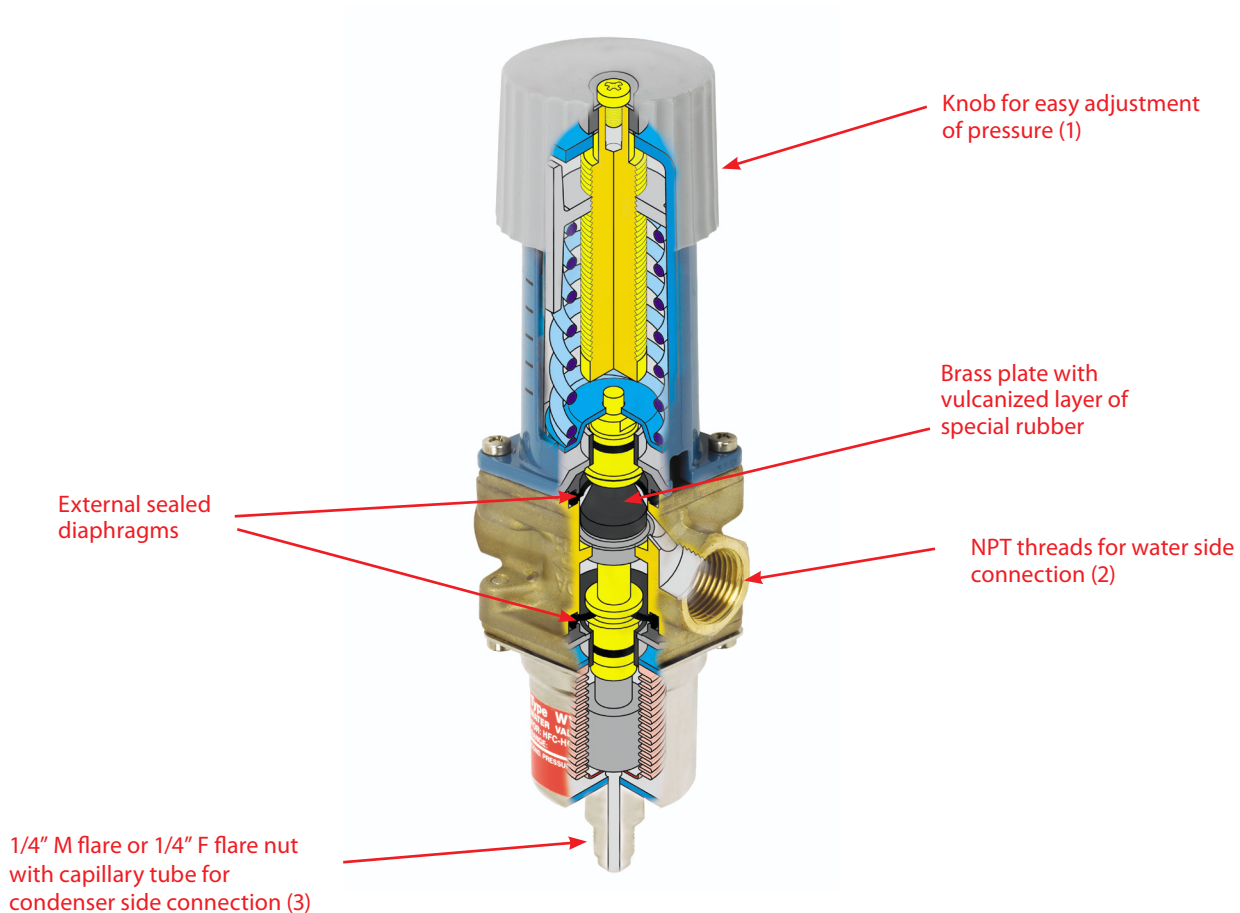

**Product Selection**

Type	Competitor Part No.	Connection		Range (psig)	Condenser side		Water side		Flow Coefficient, C <sub>v</sub> value (gal/min)	Weight (lbs)	Code No.
		Water side (NPT)	Condenser side		Max. working pressure (psig)	Max. test pressure (psig)	Max. working pressure (psig)	Max. test pressure (psig)			
WVFX 10	V46AA-1C <sup>1</sup>	3/8	1/4" M flare	60 to 333	380	420	230	350	1.6	2.55	<b>003N5006</b>
WVFX 10	V46AA-1C	3/8	1/4" F flare nut with 35" capillary tube	60 to 333	380	420	230	350	1.6	2.72	<b>003N5005</b>
WVFX 15	V46AB-1C <sup>1</sup>	1/2	1/4" M flare	60 to 333	380	420	230	350	2.2	2.48	<b>003N6006</b>
WVFX 15	V46AB-1C	1/2	1/4" F flare nut with 35" capillary tube	60 to 333	380	420	230	350	2.2	2.64	<b>003N6005</b>
WVFX 20	V46AC-1C <sup>1</sup>	3/4	1/4" M flare	60 to 333	380	420	230	350	3.9	2.53	<b>003N7006</b>
WVFX 20	V46AC-1C	3/4	1/4" F flare nut with 35" capillary tube	60 to 333	380	420	230	350	3.9	2.7	<b>003N7005</b>
WVFX 25	V46AD-1C <sup>1</sup>	1	1/4" M flare	60 to 333	380	420	230	350	6.4	2.86	<b>003N8006</b>
WVFX 25	V46AD-1C	1	1/4" F flare nut with 35" capillary tube	60 to 333	380	420	230	350	6.4	3.13	<b>003N8005</b>

Temperature range: -13 to 265°F  
 Opening differential pressure: 145 psig

<sup>1</sup>Competitor valve equipped with capillary tube as in Code No. directly below. Else, see Accessory section for capillary tube spare part to attach to this Code No.



**Introduction and Overview**

Danfoss has a variety of pressure regulators to control the low and high pressure sides and efficient function of a refrigeration system under varying load conditions. Pressure regulators include:

- Evaporator Pressure Regulator, KVP
- Crankcase Pressure Regulator, KVL
- Condensing Pressure Regulator, KVR + NRD
- Hot Gas Bypass Valves, KVC/CPCE

Some of features include:

- All valves available for use with any CFC, HCFC or HFC refrigerant, except R-410A
- Accurate pressure regulation
- Very stable
- Angle design for easy installation and replacement in field
- Hermetic brazed construction 100% leak tested
- Available with flare and ODF solder connections
- Stainless steel bellows
- Built-in valve seat dampening design
- 1/4" Schrader valve for pressure testing
- Pressure regulation side
  - KVP/KVR – opens on a rising pressure
  - KVC/KVL – opens on a falling pressure



**Product Selection**

Application	Type	Rated capacity (tons)				Solder ODF connection (in.)	Setting Range (psig)	Factory setting (psig)	Max Working Pressure (psig)	Max Test Pressure (psig)	Min Temp. of Medium (°F)	Max Temp. of Medium (°F)	Weight (lbs)	Code No.
		R-22	R-134a	R-404A	R-407C									
Evaporating Pressure Regulator	KVP 12	1.3	0.9	1.2	1.2	1/2	0 to 80	29	261	26	-49	266	0.9	034L0023
	KVP 15	1.3	0.9	1.2	1.2	5/8	0 to 80	29	261	26	-49	266	0.9	034L0029
	KVP 22	1.3	0.9	1.2	1.2	7/8	0 to 80	29	261	26	-49	266	0.9	034L0025
	KVP 28	2.8	1.9	2.4	2.6	1 1/8	0 to 80	29	261	40	-49	266	2	034L0026
	KVP 35	2.8	1.9	2.4	2.6	1 3/8	0 to 80	29	261	40	-49	266	2	034L0032
Crankcase Pressure Regulator	KVL 12	1.3	0.8	1	1.1	1/2	3 to 85	29	261	287	-76	266	0.9	034L0043
	KVL 15	1.3	0.8	1	1.1	5/8	3 to 85	29	261	287	-76	266	0.9	034L0049
	KVL 22	1.3	0.8	1	1.1	7/8	3 to 85	29	261	287	-76	266	0.9	034L0045
	KVL 28	4.1	2.6	3.4	3.8	1 1/8	3 to 85	29	261	287	-76	266	2	034L0046
	KVL 35	4.1	2.6	3.4	3.8	1 3/8	3 to 85	29	261	287	-76	266	2	034L0052
Condensing Pressure Regulator	KVR 12	Liquid: 12.7 Hot gas: 4.13	Liquid: 11.8 Hot gas: 3.03	Liquid: 8.2 Hot gas: 3.27	Liquid: 13.8 Hot gas: 4.5	1/2	70 to 250	145	400	450	-40	275	0.88	034L0093
	KVR 15	Liquid: 12.7 Hot gas: 4.13	Liquid: 11.8 Hot gas: 3.03	Liquid: 8.2 Hot gas: 3.27	Liquid: 13.8 Hot gas: 4.5	5/8	70 to 250	145	400	450	-40	275	0.88	034L0097
	KVR 22	Liquid: 12.7 Hot gas: 4.13	Liquid: 11.8 Hot gas: 3.03	Liquid: 8.2 Hot gas: 3.27	Liquid: 13.8 Hot gas: 4.5	7/8	70 to 250	145	400	450	-40	275	0.88	034L0094
	KVR 28	Liquid: 32.6 Hot gas: 10.93	Liquid: 30.2 Hot gas: 8.04	Liquid: 20.9 Hot gas: 8.66	Liquid: 35.5 Hot gas: 11.91	1 1/8	70 to 250	145	400	450	-40	275	2.2	034L0095
	KVR 35	Liquid: 32.6 Hot gas: 10.93	Liquid: 30.2 Hot gas: 8.04	Liquid: 20.9 Hot gas: 8.66	Liquid: 35.5 Hot gas: 11.91	1 3/8	70 to 250	145	400	450	-40	275	2.2	034L0100
Differential Pressure Regulator	NRD 12s *					1/2	70 to 250	145	400	530	-40	275	0.22	020-1132
Hot Gas Bypass	KVC 12	2.14	1.36	2.02	2.31	1/2	3 to 85	29	400	450	-49	266	0.88	034L0143
	KVC 15	4.17	2.65	3.93	4.5	5/8	3 to 85	29	400	450	-49	266	0.88	034L0147
	KVC 22	5.35	3.41	5.04	5.78	7/8	3 to 85	29	400	450	-49	266	0.88	034L0144
	CPCE 12	6.2	4.3	6.3	6.7	1/2	0 to 85	5.8	400	450	-50	285	2	034N0082
	CPCE 15	9.2	6.3	9.1	9.9	5/8	0 to 85	5.8	400	450	-50	285	2	034N0083
	CPCE 22	12.2	8.4	12.1	12.2	7/8	0 to 85	5.8	400	450	-50	285	2	034N0084

\* NRD generally used in conjunction with a KVR to regulate the condensing pressure.

**Introduction and Overview**

Danfoss DCL/DCB filter driers offer industry leading system protection. These driers use a mixture of molecular sieve and activated alumina to both adsorb system moisture and capture acid and prevent solid contaminants from entering the system. Moisture can clog an expansion device with ice, reducing system efficiency, or can form acids which damage the compressor and other components. Solid contaminants can clog expansion devices and wear compressors prematurely. For aftermarket service, most contractors choose this blend of molecular sieve and activated alumina for both high moisture capacity and acid adsorption capacity. Type DAS are used in the suction line to clean up refrigeration and AC systems with fluorinated refrigerants after a compressor burn-out. The solid core adsorbs harmful acids as well as moisture to protect the compressor from premature failure.



Danfoss filter driers function as simple drop-in replacements for most driers sold in the aftermarket or installed on equipment by manufacturers. All Danfoss filter driers are constructed with a solid core design to maximize moisture removal while minimizing pressure drop. Other product features and benefits are depicted in the picture below.

Black, high-quality and durable coating offers a cleaner appearance after brazing.

One-piece plasma welded shell minimizes risk of refrigerant loss.

Easy to remove pull-off cap for sweat or twist-off cap for flare.

High dirt retention – down to 25 µm particles – with minimal pressure drop.

ELIMINATOR® core for the highest possible drying capacity.



**Nomenclature**

Filter drier **D C L 03 2 s VV**

Access valves

	Inlet	Outlet
<b>(blank)</b>	blank	none
<b>V</b>	Schrader valve	
<b>VV</b>	Schrader valve	Schrader valve

Connection type  
**(blank):** Flare connection  
**s:** Solder connection

Connection (filter connection in 1/8 of an inch increments)  
**2:** 1/4 in  
**2.5:** 5/16 in  
**3:** 3/8 in  
**4:** 1/2 in  
**5:** 5/8 in  
**6:** 3/4 in  
**7:** 7/8 in  
**9:** 1 1/8 in

Solid Core  
**A:** Core with 70% molecular sieve / 30% activated alumina (burn-out)  
**C:** Core with 80% molecular sieve / 20% activated alumina  
**M:** Core with 100% molecular sieve

Application  
**B:** Bi-flow  
**L:** Liquid line  
**S:** Suction line

Size (volume)  
**03:** 3 in<sup>3</sup>  
**05:** 5 in<sup>3</sup>  
**08:** 8 in<sup>3</sup>  
**16:** 16 in<sup>3</sup>  
**30:** 30 in<sup>3</sup>  
**41:** 41 in<sup>3</sup>  
**60:** 60 in<sup>3</sup>  
**75:** 75 in<sup>3</sup>

**Quick Select Guide**
**Filter Driers, Types DCL/DCB/DAS**

Type	Connection solder (in.)	Weight (lbs)	Code No.
DCL 032s	1/4	0.39	<b>023Z5013*</b>
DCL 033s	3/8	0.42	<b>023Z5015</b>
DCL 052s	1/4	0.81	<b>023Z5018</b>
DCL 053s	3/8	0.84	<b>023Z5019</b>
DCL 082s	1/4	0.84	<b>023Z5022</b>
DCL 083s	3/8	0.86	<b>023Z5023</b>
DCL 084s	1/2	0.88	<b>023Z5026</b>
DCL 162s	1/4	1.69	<b>023Z5028</b>
DCL 163s	3/8	1.72	<b>023Z5029</b>
DCL 164s	1/2	1.74	<b>023Z5032</b>
DCL 165s	5/8	1.76	<b>023Z5033</b>
DCL 167s	7/8	1.85	<b>023Z5034</b>
DCL 303s	3/8	2.84	<b>023Z0030</b>
DCL 304s	1/2	2.86	<b>023Z0031</b>
DCL 305s	5/8	2.88	<b>023Z0032</b>
DCL 307s	7/8	2.97	<b>023Z0034</b>
DCL 309s	1 1/8	2.99	<b>023Z0035</b>
DCL 414s	1/2	4.47	<b>023Z0104</b>
DCL 415s	5/8	4.49	<b>023Z0105</b>
DCL 417s	7/8	4.58	<b>023Z0106</b>
DCL 419s	1 1/8	4.60	<b>023Z0107</b>
DCL 607s	7/8	5.26	<b>023Z0036</b>
DCL 609s	1 1/8	5.28	<b>023Z0037</b>
DCL 757s	7/8	7.44	<b>023Z0115</b>
DCB 082s	1/4	1.1	<b>023Z1434</b>
DCB 083s	3/8	1.1	<b>023Z1433</b>
DCB 084s	1/2	1.3	<b>023Z1432</b>
DCB 163s	3/8	1.8	<b>023Z1437</b>
DCB 164s	1/2	1.8	<b>023Z1436</b>
DCB 165s	5/8	2.0	<b>023Z1435</b>
DCB 304s	1/2	2.2	<b>023Z1440</b>
DCB 305s	5/8	2.4	<b>023Z1439</b>
DCB 307s	7/8	2.4	<b>023Z1438</b>
DAS 083sVV	3/8	1.0	<b>023Z1003</b>
DAS 084sVV	1/2	1.1	<b>023Z1004</b>
DAS 085sVV	5/8	1.1	<b>023Z1005</b>
DAS 086sVV	3/4	1.1	<b>023Z1006</b>
DAS 164sVV	1/2	2.03	<b>023Z1009</b>
DAS 165sVV	5/8	1.9	<b>023Z1010</b>
DAS 166sVV	3/4	1.9	<b>023Z1011</b>
DAS 167sVV	7/8	1.9	<b>023Z1012</b>
DAS 305sVV	5/8	2.9	<b>023Z1013</b>
DAS 306sVV	3/4	2.9	<b>023Z1014</b>
DAS 307sVV	7/8	2.9	<b>023Z1015</b>
DAS 309sVV	1 1/8	3.0	<b>023Z1016</b>
DAS 417sVV	7/8	4.6	<b>023Z1017</b>
DAS 419sVV	1 1/8	4.6	<b>023Z1018</b>
DAS 607sVV	7/8	5.3	<b>023Z1019</b>
DAS 609sVV	1 1/8	5.3	<b>023Z1020</b>

Type	Connection flare (in.)	Weight (lbs)	Code No.
DCL 032	1/4	0.44	<b>023Z5000*</b>
DCL 032	1/4	0.44	<b>023Z5075</b>
DCL 033	3/8	0.51	<b>023Z5001*</b>
DCL 033	3/8	0.51	<b>023Z5089</b>
DCL 052	1/4	0.86	<b>023Z5002</b>
DCL 053	3/8	0.92	<b>023Z5003</b>
DCL 082	1/4	0.88	<b>023Z5004</b>
DCL 083	3/8	0.97	<b>023Z5005</b>
DCL 084	1/2	1.06	<b>023Z5006</b>
DCL 162	1/4	1.74	<b>023Z5007</b>
DCL 163	3/8	1.80	<b>023Z5008</b>
DCL 164	1/2	1.91	<b>023Z5009</b>
DCL 165	5/8	2.00	<b>023Z5010</b>
DCL 303	3/8	2.93	<b>023Z0012</b>
DCL 304	1/2	3.04	<b>023Z0013</b>
DCL 305	5/8	3.12	<b>023Z0014</b>
DCL 306	3/4	3.28	<b>023Z0156</b>
DCL 413	1 1/8	4.09	<b>023Z0101</b>
DCL 414	1/2	4.20	<b>023Z0102</b>
DCL 415	5/8	4.29	<b>023Z0103</b>
DCB 082	1/4	1.1	<b>023Z1402</b>
DCB 083	3/8	1.1	<b>023Z1401</b>
DCB 084	1/2	1.3	<b>023Z1400</b>
DCB162	1/4	1.8	<b>023Z1406</b>
DCB 163	3/8	1.8	<b>023Z1405</b>
DCB 164	1/2	2.0	<b>023Z1404</b>
DCB 165	5/8	2.0	<b>023Z1403</b>
DAS 083VV	3/8	1.12	<b>023Z1001</b>
DAS 084VV	1/2	1.37	<b>023Z1002</b>
DAS 164VV	1/2	2.01	<b>023Z1007</b>
DAS 165VV	5/8	2.09	<b>023Z1008</b>

\* Wire mesh in filter drier outlet

Type	Material	Code No.
DCR core insert, type 48-DC solid core	80% molecular sieve & 20% activated alumina	<b>023U4381</b>
DCR core insert, type 48-DA solid core	30% molecular sieve & 70% activated alumina	<b>023U5381</b>

Introduction and Overview

GBC valves are used in liquid, suction and hot gas lines in all refrigeration and air-conditioning systems with fluorinated refrigerants. Danfoss GBC ball valves are manually operated shut-off valves suitable for bi-directional flow (1,2). The design is based on years of experience. The valve concept includes a high precision laser welding (3) ensuring both a strong and a light slim line valve body design. The design, weld, and choice of the sealing material enables the ball valves to meet the most demanding requirements, for example, the high working pressure when operating with R-410A. Additional features include:



- Seal cap with retaining strap (4)
- Burst proof spindle design prevents liquid from being trapped internally (5)
- Rotation stops and position indicator (6)
- Access port with schrader valve saves money if service of the system is necessary (7)
- Valve seat of teflon to secure maximum tightness and a long lifetime (8)
- Threaded holes for panel mounting holes – M4 (9)
- Full flow with minimum pressure drop
- Slim-line design ensures easy operational handling

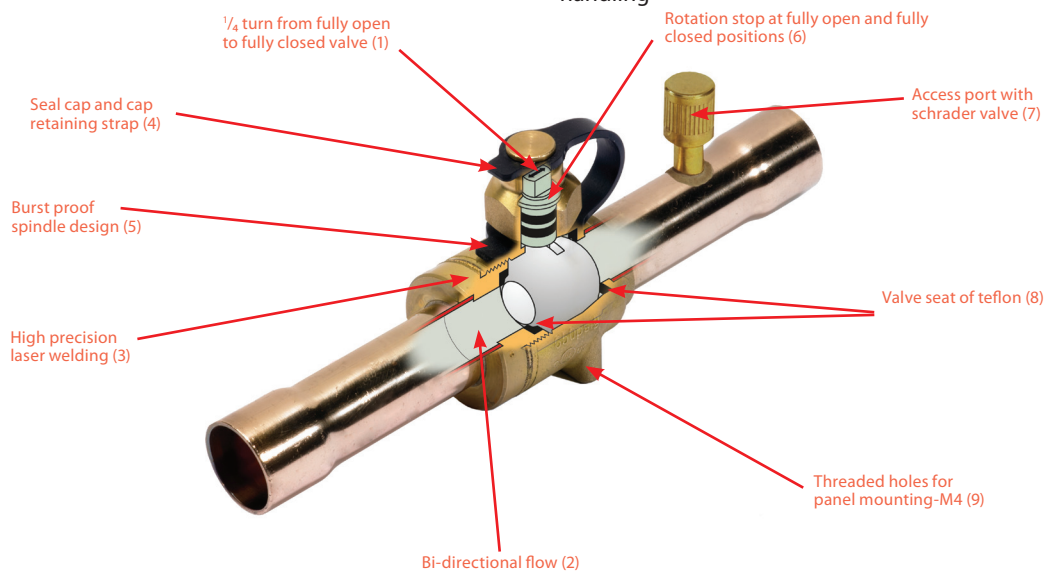

Product Selection

Type	Solder ODF connection (in.)	Flow Coefficient, C <sub>v</sub> value (gal/min)	Working pressure (psig)	Test pressure (psig)	Weight (lbs)	Danfoss Code No.
GBC6s	1/4	2.27	650	940	0.52	009G8050
GBC10s	3/8	6.57	650	940	0.52	009G8051
GBC12s	1/2	12.23	650	940	0.54	009G8052
GBC16s	5/8	16.31	650	940	0.54	009G8053
GBC18s	3/4	23.61	650	940	0.86	009G8054
GBC22s	7/8	32.56	650	940	0.94	009G8065
GBC28s	1 1/8	60.05	650	940	1.96	009G8066
GBC35s	1 3/8	93.51	650	940	3.09	009G8067
GBC42s	1 5/8	139.96	650	940	4.91	009G8068
GBC54s	2 1/8	260.05	650	940	9.32	009G8059
GBC67s	2 5/8	358.36	650	725	12.46	009G8069

**Introduction and Overview**

Danfoss sight glasses are designed to accurately indicate the presence of moisture in refrigeration and air-conditioning systems. When system moisture content rises above permissible levels, the “dry/green” indicator will change to yellow indicating a “wet” system. The indication of dangerous moisture levels is essential in helping prevent the formation of harmful acids which are detrimental to the system.

Danfoss offers two types of sight glasses; inline and vessel mount. Inline sight glass, type SGN is used in the system’s liquid line to indicate both the condition and moisture content of the refrigerant. They incorporate an indicator which changes color dependent on the moisture content. Type SGN is recommended for all HCFC and HFC refrigerants. Vessel sight glasses, type SGRN are specially designed to be mounted directly on either a receiver or the compressor crankcase to indicate liquid level. Type SGRN are available with a refrigerant moisture indicator which can be used with all fluorinated refrigerants.

**Product Selection**

Type	Version	Connection (in.)	Ambient Temperature (°F)	Maximum working pressure (psig)	Weight (lbs)	Code No.
SGN 6	Flare int. x ext. <sup>1</sup>	1/4 x 1/4	-60 to 175	500	0.22	<b>014-0137</b>
SGN 10		3/8 x 3/8		500	0.44	<b>014-0138</b>
SGN 12		1/2 x 1/2		500	0.66	<b>014-0139</b>
SGN 6s	ODF x ODF solder	1/4 x 1/4		500	0.22	<b>014-0142</b>
SGN 10s		3/8 x 3/8		500	0.22	<b>014-0143</b>
SGN 12s		1/2 x 1/2		500	0.44	<b>014-0144</b>
SGN 16s		5/8 x 5/8		500	0.44	<b>014-0145</b>
SGN 22s		7/8 x 7/8		400	0.44	<b>014-0147</b>
SGRN	NPT	1/2		500	0.22	<b>014-0006</b>

<sup>1</sup> can be screwed directly onto Danfoss filter drier.



**Introduction and Overview**

Specially optimized for use in household and light commercial applications, these hermetic reciprocating compressors provide high cooling capacity in an energy saving design. The compressor series can be used with multiple refrigerants including R-134a and R-404A (refrigerant dependent on model) that are perfect for cooling needs from 68 to 10K Btu/h.

Product features and options include:

- Compact construction
- Durable housing
- Optimized motor technology
- Wide voltage range
- Easy installation at lower cost
- Low noise and high energy efficiency
- Robust in tough operating conditions
- Environmentally friendly solutions



**Quick Select Guide**
**Light Commercial Compressors, Types BD/T/N/S**
**Product Selection**

Refrigerant	Voltage/ Phase/ Frequency	HP rating	HS/LS	Competitor Model No.	Danfoss Model No.	Capacity Btu/h <sup>1</sup> ASHRAE*									Weight (lbs) <sup>2</sup>	Single packed Code No. <sup>3</sup>	
						LBP Evaporator temperature (°F)			MBP Evaporator temperature (°F)			HBP Evaporator temperature (°F)					
						-30	-13	0	0	+20	+40	+25	+45	+50			
R-134a	12-24 DC, 100-240/1/ 50/60	multi- speed			BD35F		194	299	221	421					9.5	195B0679	
R-134a	12-24 DC, 100-240/1/ 50/60	multi- speed			BD50F		242	370	305	545					9.5	195B0678	
R-134a	115/1/60	1/5	LS		TL2.5F		215	337	255	466					14.7	195B0299	
R-134a	100-115/1/60	1/4	HS	AZA0370YXA AEA3414YXA	TL4G		320	516	393	732	1225	840	1375	1530	16.7	195B0003	
R-134a	115-127/1/60	1/3	HS	AEA1360YXA AEA3425YXA	NF5.5FX		374	701	1035	845	1442	2293	1633	2562	22.0	195B0259	
R-134a	115-127/1/60	1/3	HS	AEA4430YXA AEA3430YXA	NEK6160Z NF7FX		465	830	1206	1022	1708	2700	1925	3006	22.0	195B0467	
R-134a	115-127/1/60	1/3	HS	AEA4440YXA AEA3440YXA	NEK6187Z FF10HBK FF8.5HBKW	NF11FX		553	1046	1568	1333	2279	3638	2575	4056	22.0	195B0388
R-134a	115/1/60	2/5	HS	AEA4448YXA AEA2410YXA	SC12G		499	1126	1769	1344	2536	4242	2908	4765	5333	27.7	195B0042
R-134a	115/1/60	2/5	HS		SC15G		1266	2059	1556	3040	4969	3473	5544	6162	27.7	195B0099	
R-134a	115/1/60	1/2+	HS	AKA4460YXA AEA2413YXA	T6215Z FF112HBX	SC18G		1582	2462	1882	3479	5586	3950	6217	6896	30.2	195B0276
R-404A	115-127/1/60	1/5	HS		TF4CLX		421	714	1008	791	1285	1953			17.9	195B0666	
R-404A	115-127/1/60	1/4	HS	AEA2380ZXA	TFS4.5CLX		569	933	1297						17.9	195B0667	
R-404A	115/1/60	1/4	HS	AEA9415ZXA AEA9422ZXA	NF5.5CLX		789	1276	1759	1384	2209	3334			22.2	195B0348	
R-404A	115/1/60	1/3	HS	AEA2411ZXA AKA9427ZXA	NF7CLX		960	1587	2209	1727	2789	4237			22.2	195B0304	
R-404A	115/1/60	3/5	HS	AKA9438ZXA	SC12MLX				2640	4391	6865				30.2	195B0510	
R-404A	115/1/60	3/5	HS	AJA2419ZXA	NEK2125GK NEK2134GK	SC12CLX.2		1419	2496	3525					27.7	195B0491	
R-404A	115/1/60	3/4	HS	AJA2425ZXA	NEK2150GK NT2168GKV	SC15CLX.2		1834	3118	4391					30.9	195B0237	
R-404A	115/1/60	3/4	HS	AKA9455ZXA	NT6217GK	SC18MLX			5025	3894	6296	9691			30.9	195B0306	
R-404A	115/1/60	3/4	HS		NT6220GKV	SC18CLX.2		2198	3611	4873	3942	5929			30.9	195B0464	

<sup>1</sup> Capacity at ASHRAE conditions mentioned below. For other conditions and/or speeds, check Coolselector or contact Danfoss.

<sup>2</sup> Weight without electrical and non-electrical equipment.

<sup>3</sup> Code No. shipped with compressor and required electrical and non-electrical accessories.

**Test conditions**

Condensing temperature  
Ambient and suction gas temperature  
Liquid temperature  
Speed

**ASHRAE (LBP)\***

110°F  
90°F  
90°F  
3500

**ASHRAE (MBP)\***

130°F  
95°F  
115°F  
3500

**ASHRAE (HBP)\***

130°F  
95°F  
115°F

**Introduction and Overview**

Optyma™ is the widest range of hermetic condensing units on the market. Optyma™ condensing unit is available with high capacity models of reciprocating and scroll compressors so to cover a large range of commercial refrigeration applications, reducing costs and complexity of the systems. All Optyma™ condensing units are extremely efficient and reliable. That means less energy consumption and less running costs, less cost for service and maintenance.

**Nomenclature / Model No.**

1. Application
2. Design
3. Refrigerant
4. Condenser size
5. hp rating
6. Certification
7. Version
8. Electrical code

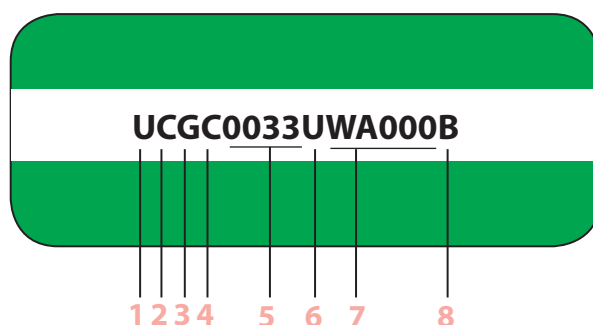

Low	1	L
Medium/High		H
Universal Low/Med/High		U

<b>C:</b> Air cooled condenser, single fan, hermetic compressor	2
<b>G:</b> Air cooled condenser, dual fan, hermetic compressor	

R-12 replacement	3	B
R-134a		G
R-404A/R-507		H
R-22		M
R-404A/R-134a/R-507/R-407C		Z

Condenser size - sized for 110°F ambient

hp rating in hundredths of hp -  
i.e. 0033 = 1/3 hp  
1000 = 10 hp

<b>R:</b> UL Recognized	6
<b>U:</b> UL Listed	

<b>W</b>	=	<b>Wholesale model</b>	7
<b>A</b>	=	<b>Power cord</b>	
<b>B</b>	=	<b>Power cord, receiver</b>	
<b>C</b>	=	<b>Electrical box, power cord, receiver</b>	
<b>D</b>	=	<b>Electrical box, receiver, low pressure control, cartridge fan cycling</b>	
<b>E</b>	=	<b>Electrical box, receiver, dual pressure control, cartridge fan cycling control, larger than 3 hp dual fan units use KPU fan cycling control</b>	
<b>F</b>	=	<b>WE + filter drier, sight glass, solenoid valve with coil</b>	
Fan Motor Version			
000	=	Standard unit	
300	=	Complies with California standards	

<b>B:</b> Compressor & fan(s) 115V, 1 ph, 60 Hz	8
<b>N:</b> Compressor & fan(s) 230V, 1 ph, 60 Hz	
<b>Q:</b> Compressor 208-230V, 3 ph, 60 Hz; Fan(s) 230V, 1 ph, 60 Hz	
<b>R:</b> Compressor 460V, 3 ph, 60 Hz; Fan(s) 460V, 1 ph, 60 Hz	
<b>X:</b> Compressor 575V, 3 ph, 60 Hz; Fan(s) 575V, 1 ph, 60 Hz	

Rating Conditions (ARI)		
<b>Application</b>	<b>LBP</b>	<b>MBP/HBP</b>
<b>Ambient Temp</b>	<b>90°F</b>	<b>90°F</b>
<b>Return Gas</b>	<b>40°F</b>	<b>65°F</b>
<b>SubCooling</b>	<b>5°F</b>	<b>5°F</b>

## Quick Select Guide

## Condensing Units, Type Optyma™

### Product Selection

\*Ambient temperature = 90°F

Return gas = 65°F

Subcooling = 5°F

R-22 MBP			Ambient temperature (°F)	Capacity Btu/h										
Competitor Model No.	Model No.	Code No.		ASHRAE* at evaporating temperature (°F)										
				0	5	10	15	20	25	30	35	40	45	
AEA9417 AEA0417 AEA9423 MMFH0022 MCFH0027	HCMC0025RWB000B	114N2341	90		1959	2174	2440	2705	3009	3313	3644	3975	4320	
			95		1834	2041	2294	2548	2837	3127	3442	3756	4084	
			100			1907	2149	2391	2666	2941	3239	3538	3847	
			110				1903	2124	2374	2624				
AKA9433 MCDH0036	HCMC0033UWC000B	114N2344	90		2334	2590	2886	3182	3509	3837	4187	4537	4898	
			95		2194	2436	2717	2997	3308	3619	3950	4282	4624	
			100			2283	2548	2813	3107	3401	3714	4027	4350	
			110				2258	2496	2761					
AKA9446 MCFH0049 MCFH0056	HCMC0050UWC000B HCMC0050UWC000N	114N2347 114N2348	90		3322	3682	4117	4553	5044	5535	6061	6587	7129	
			95		3135	3477	3891	4305	4771	5237	5736	6236	6750	
			100			3272	3664	4056	4497	4939	5412	5885	6371	
			110					3633	4032	4431				
	HCMC0060UWC000B HCMC0060UWC000N	114N2351 114N2352	90		3145	3736	4331	4925	5516	6108	6690	7273	7846	
			95		2907	3470	4035	4600	5163	5725	6279	6833	7377	
			100			3203	3739	4275	4809	5343	5868	6392		
			110				3233	3718	4201	4684				
AKA9461 F3AHA078	HCMC0075UWC000B HCMC0075UWC000N	114N2353 114N2354	90		3863	4603	5275	5947	6600	7252	7917	8583	9279	
			95		3700	4374	5003	5631	6255	6879	7529	8179	8866	
			100			4146	4730	5315	5911	6506	7141	7776	8454	
			110					4771	5317	5864				
AJA9470 F3AHA100	HCMC0100UWD000N	114N2355	90		4803	5320	5914	6507	7180	7853	8611	9368	10194	
			95		4635	5103	5661	6219	6866	7513	8252	8990	9799	
			100			4887	5409	5931	6552	7173	7893	8612	9405	
			110				4975	5437	6011	6584				
AWG4520 V3AH015H V3AH020H AWG4524 F3ADB201	HCMC0200UWF300N HCMC0200UWF300Q HCMC0200UWF300R	114N6604 114N6605 114N6606	90	7055	8384	9811	11334	12895	14607	16411	18304	20210	22266	
			95	6604	7897	9283	10762	12275	13932	15676	17506	19347	21331	
			100	6157	7413	8758	10190	11654	13256	14941	16706	18480	20392	
			110	5274	6453	7711	9047	10409	11897	13460	15094	16736	18503	
F3ADB301 V3AH030H F3ADB325	HCMC0250UWF300N HCMC0250UWF300Q	114N6608 114N6609	90	10824	12557	14289	16210	18131	20243	22355	24596	26926	29352	
			95	10265	11956	13647	15517	17387	19433	21479	23647	25907	28250	
			100	7324	9071	10819	12838	14858	17188	19518	22098	24853	27114	
			110	8587	10142	11696	13402	15107	16958	18809	20748	22752		
AVA4540 V3AH032H	HCMC0300UWF300N HCMC0300UWF300Q	114N6620 114N6621	90	14865	17222	19578	22225	24871	27827	30783	33990	37316	40861	
			95	14023	16350	18677	21288	23899	26809	29719	32866	36131	39604	
			100			15361	18314	21268	24642	28015	31724	34939	38350	
			110			16012	18499	20986	23743	26500	29465			
AGA4553 F3ADB401 V3AH040H	HGMC0400UWF300N HGMC0400UWF300Q	114N6627 114N6628	90	17905	20868	23832	27120	30409	34069	37730	41686	45823	50282	
			95	16899	19776	22653	25843	29032	32579	36125	39938	43931	48241	
			100	15892	18685	21478	24567	27657	31078	34499	38191	42040	46190	
			110	13949	16563	19178	22051	24924	28098	31271	34693	38240		
AGA4563 V3AH050H F3ADA501	HGMC0500UWF300N HGMC0500UWF300Q	114N6635 114N6636	90	24237	27665	31093	35054	39016	43503	47990	52867	57998	63425	
			95	23083	26401	29719	33546	37374	41712	46050	50741	55653	60919	
			100	21987	25191	28395	32085	35775	39948	44121	48636	53366	58423	
			110	20012	22966	25920	29323	32725	36571	40417	44575	48922		

**Quick Select Guide**
**Condensing Units, Type Optyma™**
**Product Selection**

\*Ambient temperature = 90°F  
 Return gas = 65°F  
 Subcooling = 5°F

R-134a MBP			Ambient temperature (°F)	Capacity Btu/h ASHRAE* at evaporating temperature (°F)									
Competitor Model Nos.	Danfoss Model No.	Code No.		0	5	10	15	20	25	30	35	40	45
AEA3425 M2FH0020 M2FH0024	UCGC0020RWA000B	114N2017	90	1052	1196	1339	1505	1671	1860	2049	2260	2472	2699
			95	1009	1148	1287	1447	1607	1790	1972	2176	2380	2601
			100	966	1100	1234	1388	1543	1719	1895	2092	2289	2502
			110	880	1004	1128	1271	1415	1577	1740	1923	2106	2304
AEA4430 M2FH0026	UCGC0025RWB000B	114N2019	90	1193	1353	1514	1699	1884	2095	2306	2541	2776	3029
			95	1151	1306	1461	1639	1818	2022	2225	2452	2680	2924
			100	1109	1258	1407	1580	1752	1948	2144	2364	2583	2819
			110	1024	1163	1301	1461	1620	1802	1983	2186	2389	
AEA4440 AEA4448 M2FHA033	HCGC0033UWC000B	114N2022	90		1709	1927	2179	2431	2717	3004	3324	3644	3986
			95		1648	1858	2101	2345	2622	2898	3208	3517	3848
			100		1586	1789	2024	2259	2526	2793	3091	3390	3709
			110		1462	1651	1869	2087	2335	2582	2859	3136	3433
AKA4460 AKA7437 M2FH0049	UCGC0050UWC000B	114N2024	90	2339	2682	3025	3420	3815	4264	4713	5212	5712	6249
			95	2245	2579	2913	3295	3678	4109	4541	5020	5499	6011
			100	2150	2476	2801	3171	3540	3954	4368	4827	5285	5774
			110	1961	2270	2578	2922	3265	3645	4024	4441	4857	5299
AJA4492 AJA7465 FTAHA074 FTAHA075 FTAHB074 FTAMA074 FTAMA075	HCGC0075UWC000B HCGC0075UWC000N	114N2027 114N2028	90		4596	5079	5774	6470	7325	8180	9129	10077	11052
			95		4276	4771	5453	6135	6952	7769	8660	9551	10458
			100		3956	4463	5131	5800	6578	7357	8190	9024	9863
			110				4582	5224	5936	6647	7383	8119	
AJA4512 FTAHA100 FTAHA101	HCGC0100UWD000N	114N2029	90		6529	7098	7794	8491	9273	10055	10885	11715	12555
			95		6003	6566	7242	7918	8670	9421	10211	11001	11797
			100			6034	6690	7346	8067	8788	9538	10288	11038
			110				5586	6202	6861	7520			

**Quick Select Guide**

**Condensing Units, Type Optyma™**

**Product Selection**

\*Ambient temperature = 90°F  
 Return gas = 65°F  
 Subcooling = 5°F

R-404A MBP			Ambient temperature (°F)	Capacity Btu/h ASHRAE* at evaporating temperature (°F)									
Competitor Model No.	Model No.	Code No.		0	5	10	15	20	25	30	35	40	45
AEA9415 M4FH0022	UCHC0020RWA000B	114N2316	90	961	1071	1181	1301	1422	1552	1682	1819	1956	2098
			95	909	1014	1119	1234	1349	1473	1597	1727	1857	1991
			100	857	957	1057	1166	1276	1393	1511	1634	1757	1884
			110	766	857	947	1047	1146	1252	1358	1469		
AEA9422 M4FH0025	UCHC0025RWB000B	114N2318	90	1625	1808	1992	2198	2405	2634	2864	3115	3367	3635
			95	1553	1730	1906	2105	2303	2524	2744	2985	3227	3484
			100	1482	1652	1821	2011	2202	2413	2624	2856	3087	3334
			110	1340	1495	1650	1824	1999	2192	2385	2596	2808	
AKA9429 M4FHA036	UCHC0033UWC000B	114N2321	90	1971	2194	2417	2666	2915	3188	3461	3756	4052	4340
			95	1882	2096	2310	2548	2787	3049	3311	3594	3877	4153
			100	1792	1997	2203	2431	2659	2910	3160	3431	3702	3966
			110	1659	1851	2043	2256	2470	2704	2937	3190		
AKA9440 M4FH0050	UCHC0050UWC000B UCHC0050UWC000N	114N2324	90	2519	2838	3158	3518	3878	4279	4679	5119	5560	6030
			95	2386	2695	3004	3351	3699	4086	4472	4897	5323	5778
		114N2325	100	2253	2551	2849	3185	3520	3893	4265	4676	5086	5525
			110	2154	2444	2734	3060	3386	3748	4110	4509	4908	5335
AJA7480 FJAMA100 FJAMA101 FJAMA106 FJAF100	HCHC0100UWD000N	114N2332	90		4964	5543	6205	6867	7614	8360	9194	10027	10928
			95		4791	5319	5943	6566	7284	8002	8815	9629	10515
			100			5095	5680	6265	6954	7644	8437	9230	10101
			110				5230	5749	6388	7027	7784	8540	
AWA7512 FJAMA125 FJAMA126 FJAMA150	HCZC0150UWF300N HCZC0150UWF300Q HCZC0150UWF300R	114N6401	90	6365	7471	8647	9891	11153	12524	13954	15440	16921	18503
			95	5950	7009	8134	9323	10528	11835	13199	14614	16025	17531
		114N6402	100	5529	6542	7616	8750	9897	11141	12438	13783	15124	16554
			110	4686	5600	6570	7591	8623	9740	10902	12108	13308	14588
AWA7515 VJAF017H FJAMA200	HCZC0200UWF300N HCZC0200UWF300Q HCZC0200UWF300R	114N6404	90	8793	10070	11423	12848	14286	15836	17439	19089	20716	22434
			95	8315	9529	10814	12164	13525	14990	16504	18061	19596	21217
		114N6405	100	7818	8969	10185	11461	12744	14125	15551	17017	18461	19986
			110	6778	7801	8877	10003	11133	12346	13598	14883	16149	17497
VJAF025H	HCZC0250UWF300N HCZC0250UWF300Q	114N6408	90	11258	12870	14483	16253	18023	19974	21992	24108	26223	28532
			95	10640	12182	13723	15412	17101	18963	20887	22903	24920	27134
		114N6409	100	10008	11478	12947	14554	16162	17933	19765	21689	23613	25720
			110	8732	10057	11382	12827	14273	15867	17518	19256	20994	
AVA7523 FJAMA300 VJAF030H FJAMA325	HCZC0300UWF300N HCZC0300UWF300Q	114N6420	90	15776	18105	20434	22974	25514	28281	31145	34130	37115	40306
			95	14841	17062	19284	21704	24125	26775	29493	32347	35201	38255
		114N6421	100	13910	16023	18136	20438	22739	25260	27846	30557	33268	36201
			110	12102	14000	15898	17964	20031	22301	24644			
VJAF035Z VJAF035H	HGZC0400UWF300N HGZC0400UWF300Q	114N6427 114N6408	90	20074	23089	26103	29451	32798	36521	40377	44475	48573	53103
			95	18817	21706	24596	27802	31008	34575	38286	42213	46140	50500
			100	17545	20307	23068	26131	29194	32604	36155	39922	43689	47866
			110	15020	17523	20026	22804	25583	28683	31918	35364	38809	



**Quick Select Guide**
**Condensing Units, Type Optyma™**
**Product Selection**

\*Ambient temperature = 90°F  
 Return gas = 65°F  
 Subcooling = 5°F

R-404A MBP			Ambient temperature (°F)	Capacity Btu/h ASHRAE* at evaporating temperature (°F)										
Competitor Model No.	Model No.	Code No.		0	5	10	15	20	25	30	35	40	45	
FJAMB400 VJAF040Z VJAF040H FJAMB500 VJAF050Z	HGZC0500UWF300N HGZC0500UWF300Q	114N6435	90	24167	27679	31192	35047	38902	43145	47507	52087	56667	61623	
			95	22592	25935	29279	32946	36612	40649	44796	49160	53523	58258	
		114N6436	100	21011	24184	27357	30833	34310	38139	42094	46221	50349	54852	
			110	17904	20734	23565	26663	29762	33179	36713	40415	44117		
FJAH100Z	HGZC1000UWF300Q HGZC1000UWF300R	114N6445	90	50572	57395	64218	71795	79372	87743	96495	105668	115042		
			95	47531	54059	60587	67833	75078	83083	91458	100240	109214		
		114N6446	100	44478	50707	56936	63848	70760	78397	86396	94789	103367		
			110	38467	44098	49729	55982	62236	69152	76414	84053	91921		
CJDM1000	HGZC1200UWF300Q HGZC1200UWF300R	114N6448	90	58238	65784	73330	81645	89960	99106	108643	118562	128799		
			95	54773	61980	69186	77124	85063	93843	102910	112381	122060		
		114N6449	100	51292	58154	65015	72574	80133	88502	97144	103232	115500		
			110	44431	50602	56773	63580	70387	77948	85814	94021	102497		
FJAH120Z FJAM130Z	HGZC1350UWF300Q HGZC1350UWF300R	114N6451	90	62293	70102	77911	86496	95082	104476	114193	124446	134767		
			95	58588	66047	73506	81708	89910	98881	108213	117877	127858		
		114N6452	100	54893	61999	69105	76922	84739	93288	102196	111448	120991		
			110	47666	54091	60516	67557	74599	82383	90417	98880			

**Quick Select Guide**
**Condensing Units, Type Optyma™**
**Product Selection**

\*Ambient temperature = 90°F  
 Return gas = 65°F  
 Subcooling = 5°F

R-404A LBP			Ambient temperature (°F)	Capacity Btu/h ASHRAE* at evaporating temperature (°F)										
Competitor Model No.	Model No.	Code No.		-40	-35	-30	-25	-20	-15	-10	-5	0	5	10
	UCHC0020RWA000B	114N2316	90	327	387	447	520	593	679	764	862	961	1071	1181
			95	301	359	417	487	557	639	721	815	909	1014	1119
			100	276	332	388	455	521	600	678	767	857	957	1057
			110	233	285	336	398	460	531	603	684	766	857	947
AEA2410	UCHC0025RWB000B	114N2318	90	595	693	791	909	1026	1165	1303	1464	1625	1808	1992
			95	559	655	750	863	977	1111	1244	1399	1553	1730	1906
			100	524	616	708	818	928	1056	1185	1334	1482	1652	1821
			110	453	539	626	728	829	948	1067	1203	1340	1495	1650
AEA2413 M4FL0033	UCHC0033UWC000B	114N2321	90	699	821	944	1090	1235	1406	1577	1774	1971	2194	2417
			95	654	773	892	1033	1174	1338	1503	1692	1882	2096	2310
			100	609	724	840	976	1112	1270	1429	1611	1792	1997	2203
			110	543	653	763	891	1020	1169	1318	1489	1659	1851	2043
AKA2422 M4FL0040	UCHC0050UWC000B UCHC0050UWC000N	114N2324 114N2325	90	710	885	1060	1267	1474	1716	1959	2239	2519	2838	3158
			95	622	795	968	1170	1373	1608	1844	2115	2386	2695	3004
			100	535	705	875	1073	1271	1500	1729	1991	2253	2551	2849
			110	405	572	738	929	1120	1339	1557	1806	2055	2337	2619
AJA2429 M4FL0051	LCHC0060UWC000B LCHC0060UWC000N	114N2335 114N2336	90	1274	1511	1748	2025	2303	2622	2941	3299	3658	4054	4450
			95	1168	1395	1622	1887	2152	2455	2758	3099	3439	3815	4190
			100	1063	1280	1497	1749	2000	2288	2576	2898	3221	3576	3931
			110	876	1074	1272	1501	1729	1989	2249	2539			
M4FL0067 FJAF0075	LCHC0075UWC000B LCHC0075UWC000N	114N2337 114N2338	90	1380	1688	1996	2341	2686	3073	3460	3891	4322	4797	5272
			95	1312	1622	1933	2278	2623	3009	3394	3823	4251	4722	5193
			100		1557	1869	2214	2560	2944	3329	3755	4180	4647	5114
			110				2087	2434	2816	3198	3618	4039	4498	
AWA2448 FJALA100 FJALA101 FJALA103 FJALA102	LCHC0100UWD000N	114N2339	90	1779	2347	2915	3504	4093	4711	5329	5980	6630	7314	7998
			95	1743	2211	2678	3246	3813	4409	5005	5632	6259	6916	7574
			100		2074	2442	2988	3533	4107	4681	5284	5887	6518	7150
			110				2471	2973	3503	4032	4588	5144	5723	6302
AWA2479 AWA2490 AVA2510 FJALB200 FJALA225	LCZC0200UWF300N LCZC0201UWF300Q LCZC0201UWF300R	114N6729 114N6730 114N6731	90	4953	5934	6985	8061	9238	10472	11757	13038	14404	15799	17217
			95	4585	5523	6525	7549	8666	9836	11052	12264	13553	14870	16204
			100	4236	5131	6085	7056	8114	9220	10369	11510	12724	13961	15212
			110	3586	4397	5254	6122	7063	8042	9054	10056	11117	12193	13277
AVA2512 AVA2515 VJAL025Z FJALB301 VJAL035Z	LCZC0301UWF300N LCZC0301UWF300Q LCZC0301UWF300R	114N6733 114N6734 114N6735	90	6108	7619	9247	10912	12723	14600	16525	18408	20368	22317	24237
			95	5628	7070	8614	10189	11894	13658	15460	17219	19045	20855	22633
			100	5138	6512	7975	9460	11063	12714	14397	16033	17728	19402	21053
			110	4140	5375	6679	7989	9391	10823	12272	13670	15106	16526	17889
VJAL040Z VJAL050Z	LGZC0401UWF300N LGZC0401UWF300Q LGZC0401UWF300R	114N6737 114N6738 114N6739	90	8907	10928	13112	15368	17855	20487	23251	26032	29023	32109	35275
			95	8170	10112	12209	14369	16747	19258	21891	24537	27379	30307	33307
			100	7439	9304	11313	13378	15646	18037	20540	23050	25743	28514	31349
			110	6009	7726	9551	11422	13469	15617	17858	20098	22494	24950	27455

**Quick Select Guide**
**Condensing Units, Type Optyma™**
**Product Selection**

\*Ambient temperature = 90°F  
 Return gas = 65°F  
 Subcooling = 5°F

R-404A LBP			Ambient temperature (°F)	Capacity Btu/h ASHRAE* at evaporating temperature (°F)										
Competitor Model No.	Model No.	Code No.		-40	-35	-30	-25	-20	-15	-10	-5	0	5	10
CJDL0600	LGZC0600UWF300Q LGZC0600UWF300R	114N6741	90	14093	16971	20081	23290	26827	30564	34487	38430	42667	47035	51512
		114N6742	95	12860	15622	18602	21669	25040	28594	32316	36051	40057	44180	48400
			100	11606	14266	17106	20030	23235	26607	30130	33659	37437	41319	45285
			110	9080	11509	14095	16720	19593	22601	25730	28850	32179	35585	39051
CPDK0600	LGZC0751UWF300Q LGZC0750UWF300R	114N6744	90	19051	22596	26384	30245	34439	38796	43286	47709	52359	57039	61714
		114N6745	95	17672	21054	24655	28312	32274	36379	40599	44747	49099	53470	57827
			100	16289	19508	22921	26375	30105	33960	37912	41788	45844	49908	53949
			110	13530	16417	19450	22497	25765	29120	32539	35872	39341	42795	46206

**Introduction and Overview**

Maneurop® reciprocating compressors from Danfoss Commercial Compressors are specially designed for applications with a wide range of operating conditions. Maneurop® MT and MTZ series compressors are of the hermetic reciprocating type and are designed for medium and high evaporating temperature applications.

The MT series is designed for use with the “traditional” R-22 refrigerant, using Danfoss mineral oil 160P as lubricant. The MT series can also be applied with several R-22 based refrigerant blends (substitute refrigerants), using 160 ABM alkylbenzene as lubricant. The MTZ series is specifically designed for use with the HFC refrigerants R-407C, R-134a, R-404A, and R-507A, using 160PZ polyester oil as lubricant. MT and MTZ compressors have a large internal free volume that protects against the risk of liquid hammering when liquid refrigerant enters the compressor.

MT and MTZ compressors are available in 16 different models with displacement ranging from 1.84 to 16.57 in<sup>3</sup>/rev. Seven different motor voltage ranges are available for single and three phase power supplies at 50 and 60 Hz.

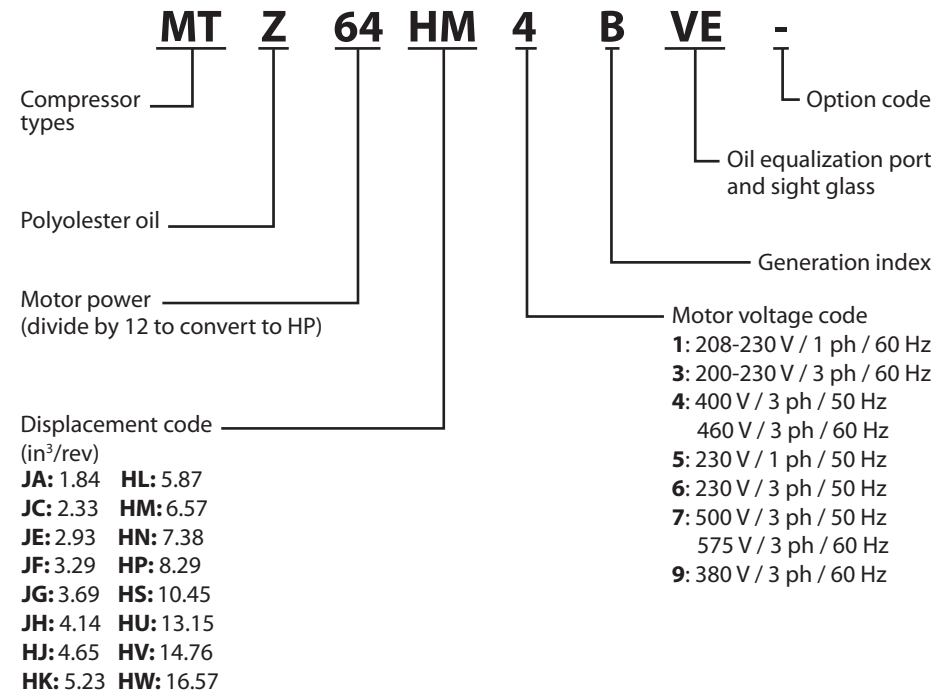
**Nomenclature / Model No.**  
 (as indicated on compressor's label)

**Product Selection**

Refrigerant	No. cylinders	Weight (lbs)	Connection type rotolock (in.)	Connection with supplied sleeve (in. ODF)	208-230/1/60		200-230/3/60		460/3/60	
					Model No.	Code No. <sup>1</sup>	Model No.	Code No. <sup>1</sup>	Model No.	Code No. <sup>1</sup>
R-22	1	46	1 x 1	1/2 x 3/8	MT18JA1PVE	<b>MT18-1VI</b>	MT18JA3MVE	<b>MT18-3VI</b>	MT18JA4BVE	<b>MT18-4VI</b>
	1	46	1 x 1	1/2 x 3/8	MT22JC1TVE	<b>MT22-1VI</b> <sup>2</sup>	MT22JC3MVE	<b>MT22-3VI</b>	MT22JC4AVE	<b>MT22-4VI</b>
	1	51	1 x 1	1/2 x 3/8	MT28JE1RVE	<b>MT28-1VI</b> <sup>2</sup>	MT28JE3MVE	<b>MT28-3VI</b>	MT28JE4AVE	<b>MT28-4VI</b>
	1	53	1 1/4 x 1	5/8 x 1/2	MT32JF1MVE	<b>MT32-1VI</b>	MT32JF3EVE	<b>MT32-3VI</b>	MT32JF4DVE	<b>MT32-4VI</b>
	1	55	1 1/4 x 1	5/8 x 1/2	MT36JG1QVE	<b>MT36-1VI</b>	MT36JF3FVE	<b>MT36-3VI</b>	MT36JG4EVE	<b>MT36-4VI</b>
	1	57	1 1/4 x 1	5/8 x 1/2	MT40JH1NVE	<b>MT40-1VI</b>	MT40JH3FVE	<b>MT40-3VI</b>	MT40JH4EVE	<b>MT40-4VI</b>
	2	77	1 3/4 x 1 1/4	7/8 x 3/4	MT44HJ1FVE	<b>MT44-1VI</b>	MT44HJ3BVE	<b>MT44-3VI</b>	MT44HJ4AVE	<b>MT44-4VI</b>
	2	77	1 3/4 x 1 1/4	7/8 x 3/4	MT50HK1GVE	<b>MT50-1VI</b>	MT50HK3CVE	<b>MT50-3VI</b>	MT50HK4BVE	<b>MT50-4VI</b>
	2	82	1 3/4 x 1 1/4	7/8 x 3/4	MT56HL1EVE	<b>MT56-1VI</b>	MT56HL3BVE	<b>MT56-3VI</b>	MT56HL4AVE	<b>MT56-4VI</b>
	2	82	1 3/4 x 1 1/4	7/8 x 3/4	MT64HM1FVE	<b>MT64-1VI</b>	MT64HM3DVE	<b>MT64-3VI</b>	MT64HM4CVE	<b>MT64-4VI</b>
	2	88	1 3/4 x 1 1/4	7/8 x 3/4			MT72HN3CVE	<b>MT72-3VI</b>	MT72HN4AVE	<b>MT72-4VI</b>
	2	88	1 3/4 x 1 1/4	1 1/8 x 3/4			MT80HP3CVE	<b>MT80-3VI</b>	MT80HP4AVE	<b>MT80-4VI</b>
	4	132	1 3/4 x 1 1/4	1 1/8 x 3/4			MT100HS3DVE	<b>MT100-3VI</b>	MT100HS4DVE	<b>MT100-4VI</b>
	4	141	1 3/4 x 1 1/4	1 1/8 x 3/4			MT125HU3DVE	<b>MT125-3VI</b>	MT125HU4DVE	<b>MT125-4VI</b>
	4	148	1 3/4 x 1 1/4	1 1/8 x 3/4			MT144HV3VE	<b>MT144-3VI</b>	MT144HV4VE	<b>MT144-4VI</b>
	4	152	1 3/4 x 1 1/4	1 1/8 x 3/4			MT160HW3DVE	<b>MT160-3VI</b>	MT160HW4DVE	<b>MT160-4VI</b>
R-404A R-134a R-407C	1	46	1 x 1	1/2 x 3/8	MTZ18JA1AVE	<b>MTZ18-1VI</b>	MTZ18JA3AVE	<b>MTZ18-3VI</b>	MTZ18JA4BVE	<b>MTZ18-4VI</b>
	1	46	1 x 1	1/2 x 3/8	MTZ22JC1BVE	<b>MTZ22-1VI</b> <sup>2</sup>	MTZ22JC3AVE	<b>MTZ22-3VI</b>	MTZ22JC4AVE	<b>MTZ22-4VI</b>
	1	51	1 x 1	1/2 x 3/8	MTZ28JE1AVE	<b>MTZ28-1VI</b> <sup>2</sup>	MTZ28JE3AVE	<b>MTZ28-3VI</b>	MTZ28JE4AVE	<b>MTZ28-4VI</b>
	1	53	1 1/4 x 1	5/8 x 1/2	MTZ32JF1AVE	<b>MTZ32-1VI</b>	MTZ32JF3AVE	<b>MTZ32-3VI</b>	MTZ32JF4BVE	<b>MTZ32-4VI</b>
	1	55	1 1/4 x 1	5/8 x 1/2	MTZ36JG1AVE	<b>MTZ36-1VI</b>	MTZ36JG3AVE	<b>MTZ36-3VI</b>	MTZ36JG4AVE	<b>MTZ36-4VI</b>
	1	57	1 1/4 x 1	5/8 x 1/2	MTZ40JH1AVE	<b>MTZ40-1VI</b>	MTZ40JH3AVE	<b>MTZ40-3VI</b>	MTZ40JH4AVE	<b>MTZ40-4VI</b>
	2	77	1 3/4 x 1 1/4	7/8 x 3/4	MTZ44HJ1AVE	<b>MTZ44-1VI</b>	MTZ44HJ3AVE	<b>MTZ44-3VI</b>	MTZ44HJ4AVE	<b>MTZ44-4VI</b>
	2	77	1 3/4 x 1 1/4	7/8 x 3/4	MTZ50HK1BVE	<b>MTZ50-1VI</b>	MTZ50HK3BVE	<b>MTZ50-3VI</b>	MTZ50HK4BVE	<b>MTZ50-4VI</b>
	2	82	1 3/4 x 1 1/4	7/8 x 3/4	MTZ56HL1BVE	<b>MTZ56-1VI</b>	MTZ56HL3AVE	<b>MTZ56-3VI</b>	MTZ56HL4AVE	<b>MTZ56-4VI</b>
	2	82	1 3/4 x 1 1/4	7/8 x 3/4	MTZ64HM1BVE	<b>MTZ64-1VI</b>	MTZ64HM3AVE	<b>MTZ64-3VI</b>	MTZ64HM4BVE	<b>MTZ64-4VI</b>
	2	88	1 3/4 x 1 1/4	7/8 x 3/4			MTZ72HN3BVE	<b>MTZ72-3VI</b>	MTZ72HN4AVE	<b>MTZ72-4VI</b>
	2	88	1 3/4 x 1 1/4	1 1/8 x 3/4			MTZ80HP3BVE	<b>MTZ80-3VI</b>	MTZ80HP4AVE	<b>MTZ80-4VI</b>
	4	132	1 3/4 x 1 1/4	1 1/8 x 3/4			MTZ100HS3VE	<b>MTZ100-3VI</b>	MTZ100HS4AVE	<b>MTZ100-4VI</b>
	4	141	1 3/4 x 1 1/4	1 1/8 x 3/4			MTZ125HU3VE	<b>MTZ125-3VI</b>	MTZ125HU4AVE	<b>MTZ125-4VI</b>
	4	148	1 3/4 x 1 1/4	1 1/8 x 3/4			MTZ144HV3VE	<b>MTZ144-3VI</b>	MTZ144HV4AVE	<b>MTZ144-4VI</b>
	4	152	1 3/4 x 1 1/4	1 1/8 x 3/4			MTZ160HW3VE	<b>MTZ160-3VI</b>	MTZ160HW4AVE	<b>MTZ160-4VI</b>

<sup>1</sup> Single compressor, threaded sight glass, 3/8" oil equalization connection

<sup>2</sup> Actual connection type for MT and MTZ 22-28 (208-230/1/60) is 1 1/4 x 1 and connection with supplied sleeve is 5/8 x 1/2

See page 46 for Nominal capacitor values and relays

**Introduction and Overview**

The Maneurop® NTZ series of reciprocating compressors from Danfoss Commercial Compressors are specially designed for low evaporating temperature applications.

The NTZ series is optimized at -31°F with an extended evaporating temperature range from -49° to 14°F. The compressors can be operated at a suction gas temperature of 68°F even at low evaporating temperatures. A liquid injection system is not required. All components are of a high quality and precision to assure a long product life. NTZ compressors have a large internal free volume that helps to reduce the risk of liquid hammering. The electrical motor is fully suction gas cooled which means that no additional body cooling is required and it allows the compressors to be insulated with an acoustic hood.

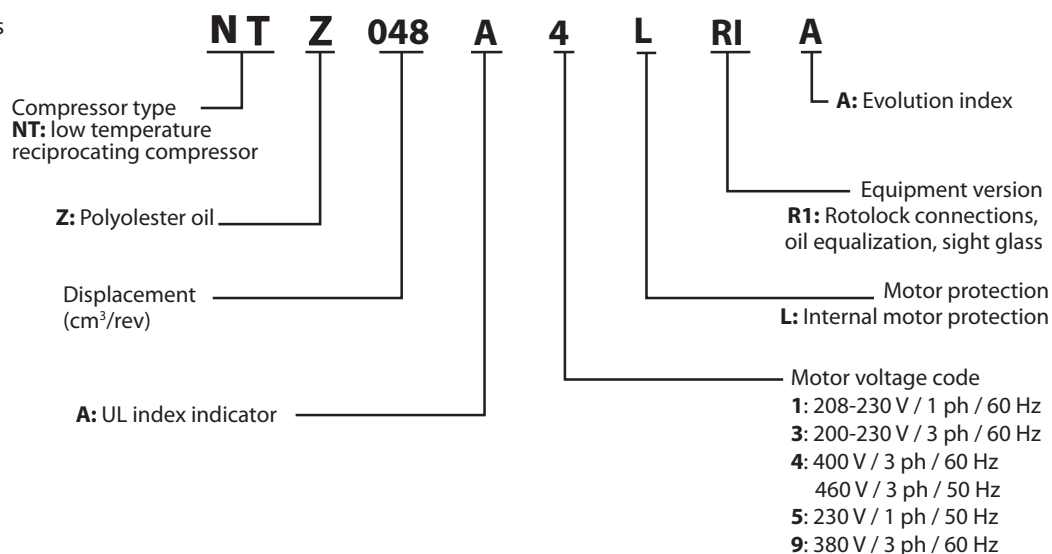
**Nomenclature / Model No.**  
 (as indicated on compressor's label)

**Product Selection**

Refrigerant	No. cylinders	Weight (lbs)	Connection type rotolock (in.)	Connection with supplied sleeve (in. ODF)	208-230/1/60		200-230/3/60		460/3/60	
					Model No.	Code No. <sup>1</sup>	Model No.	Code No. <sup>1</sup>	Model No.	Code No. <sup>1</sup>
R-404A	1	46	1 1/4 x 1	5/8 x 1/2	NTZ048A1LR1A	<b>120F0072</b>	NTZ048A3LR1A	<b>120F0026</b>	NTZ048A4LR1A	<b>120F0001</b>
	1	51	1 1/4 x 1	5/8 x 1/2	NTZ068A1LR1A	<b>120F0073</b>	NTZ068A3LR1A	<b>120F0027</b>	NTZ068A4LR1A	<b>120F0002</b>
	2	77	1 3/4 x 1 1/4	7/8 x 3/4	NTZ096A1LR1A	<b>120F0074</b>	NTZ096A3LR1A	<b>120F0028</b>	NTZ096A4LR1A	<b>120F0003</b>
	2	77	1 3/4 x 1 1/4	7/8 x 3/4	NTZ108A1LR1A	<b>120F0075</b>	NTZ108A3LR1A	<b>120F0029</b>	NTZ108A4LR1A	<b>120F0004</b>
	2	77	1 3/4 x 1 1/4	1 1/8 x 3/4	NTZ136A1LR1A	<b>120F0076</b>	NTZ136A3LR1A	<b>120F0030</b>	NTZ136A4LR1A	<b>120F0005</b>
	4	137					NTZ215A3LR1A	<b>120F0031</b>	NTZ215A4LR1A	<b>120F0006</b>
	4	141					NTZ271A3LR1A	<b>120F0032</b>	NTZ271A4LR1A	<b>120F0007</b>

<sup>1</sup> Single compressor, threaded sight glass, 3/8" oil equalization connection

See page 46 for Nominal capacitor values and relays.



**Introduction and Overview**

Danfoss Residential and Light Commercial Air Conditioning Scroll Compressors install quickly and easily. These compressors feature a design that minimizes internal parts, decreasing overall weight, and significantly reducing the sound produced during operation. With a bolt pattern and liquid and suction line connections that match up almost identically to those of other major scroll compressor manufacturers, Danfoss scroll compressors can be used to replace compressors made by both Danfoss and other companies.



**Nomenclature / Model No.**

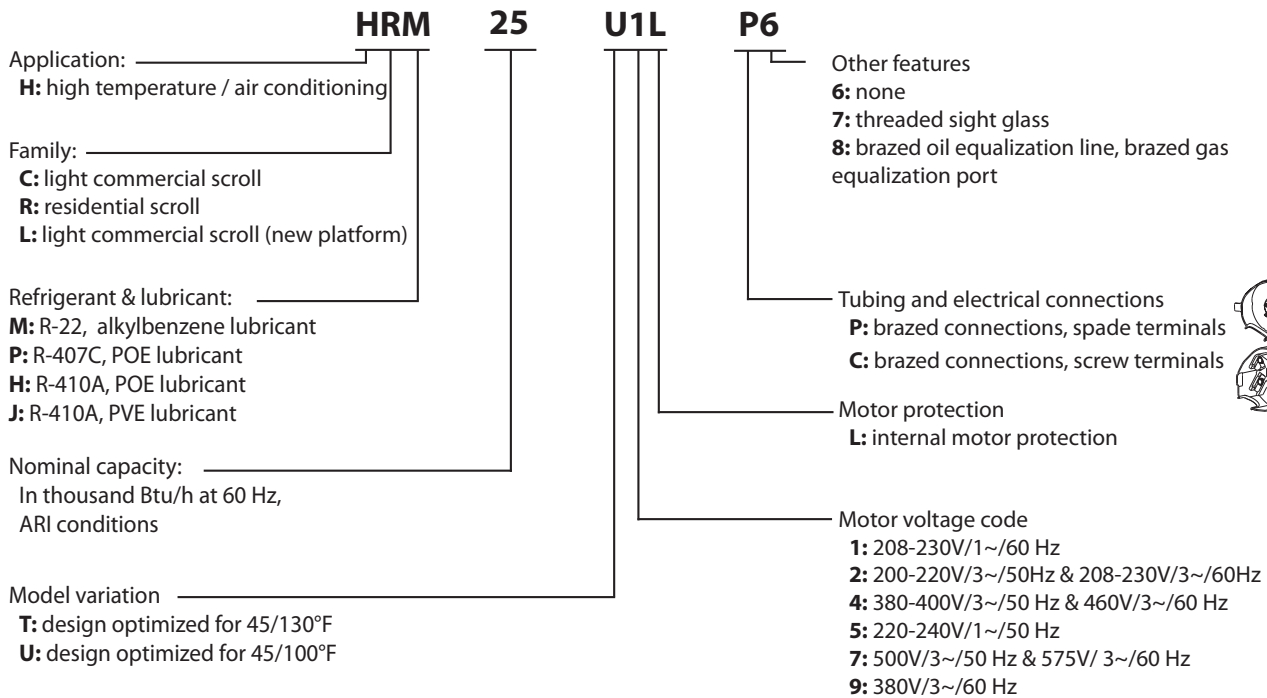

**Product Selection**

Refrigerant	Voltage/ Phase/ Frequency	Tons	Competitor Model No.	Danfoss						
				Standard Model No.	Standard Code No.	Weight (lbs)	Wholesale Model No.	Connection type (in. ODF brazed)	Wholesale Code No.	Weight (lbs)
R-22 <sup>1</sup>	208-230/1/60	2	ZR25K*-PFV	HRM025T1LP6	120U2780	68	HRM025T1LP6	3/4 x 1/2	<b>120U2780</b>	68
		2 1/2	ZR28K*-PFV	HRM032U1LP6	120U0921	68	HRM032U1LP6	3/4 x 1/2	<b>120U0921</b>	68
			ZR32K*-PFV							
		3	ZR34K*-PFV	HRM034U1LP6	120U0926	68	HRM038U1LP6	3/4 x 1/2	<b>120U0931</b>	68
			ZR36K*-PFV	HRM038U1LP6	120U0931	68				
		3 1/2	ZR40K*-PFV	HRM040U1LP6	120U0936	68	HRM042U1LP6	3/4 x 1/2	<b>120U0941</b>	68
			ZR42K*-PFV	HRM042U1LP6	120U0941	68				
		4	ZR47K*-PFV	HRM047U1LP6	120U0951	71	HRM047U1LP6	7/8 x 1/2	<b>120U0951</b>	71
		5	ZR54K*-PFV	HRM054U1LP6	120U1511	82	HRM060U1LP6	7/8 x 1/2	<b>120U1546</b>	82
			ZR57K*-PFV	HRM058U1LP6	120U1531	82				
			ZR61K*-PFV	HRM060U1LP6	120U1546	82				
		208-230/3/60	3 1/2	ZR42K*-TF5	HRM042U2LP6	120U1111	68	HRM042U2LP6	3/4 x 1/2	<b>120U1111</b>
	4		ZR47K*-TF5	HRM047U2LP6	120U1131	71	HRM047U2LP6	7/8 x 1/2	<b>120U1131</b>	71
	5		ZR54K*-TF5	HRM054U2LP6	120U1871	82	HRM060U2LP6	7/8 x 1/2	<b>120U1881</b>	82
			ZR57K*-TF5	HRM058U2LP6	120U1876	82				
			ZR61K*-TF5	HRM060U2LP6	120U1881	82				
	6		ZR72K*-TF5	HLM072T2LC6	120U1896	82	HLM075T2LC6	7/8 x 1/2	<b>120U1901</b>	87
				HLM075T2LC6	120U1901	87				
	8		ZR81KC-TF5	HLM081T2LC6	120U1911	82	HCM094T2LC6	1 1/8 x 7/8	<b>120U0891</b> <sup>2</sup>	97
			ZR94KC-TF5	HCM094T2LC6	120U0891	97				
	10		ZR125KC-TF5 ZR12M3*-TWC	HCM120T2LC6	120U0761	100	HCM120T2LC6	1 1/8 x 7/8	<b>120U0761</b> <sup>2</sup>	100
	460/3/60	4	ZR47K*-TFD	HRM047U4LP6	120U1051	71	HRM047U4LP6	7/8 x 1/2	<b>120U1051</b>	71
		5	ZR57K*-TFD	HRM058U4LP6	120U1711	82	HRM060U4LP6	7/8 x 1/2	<b>120U1736</b>	82
			ZR61K*-TFD	HRM060U4LP6	120U1736	82				
			ZR72K*-TFD	HLM072T4LC6	120U1751	82				
		6	ZR81KC-TFD	HLM075T4LC6	120U1761	82	HLM075T4LC6	7/8 x 1/2	<b>120U1761</b>	82

<sup>1</sup>Full range of models (refrigerant, tons and voltage codes) available from Danfoss. Check Coolselector or contact Danfoss.

<sup>2</sup>Additional adjustments may be required when replacing a competitor's compressor over 81K Btu/h, as suction and discharge connections may vary significantly. See page 46 for Nominal capacitor values and relays.

Quick Select Guide

Scroll Compressors, Types HRM/HLM/HCM/HRH/HLH/HLJ/H CJ

Refrigerant	Voltage/ Phase/ Frequency	Tons	Competitor Model No.	Danfoss							
				Standard Model No.	Standard Code No.	Weight (lbs)	Wholesale Model No.	Connection type (in. ODF brazed)	Wholesale Code No.	Weight (lbs)	
R-410A <sup>1</sup>	208-230/1/60	2 1/2	ZP29K5E-PFV	HRH029U1LP6	120U2277	82	HRH032U1LP6	3/4 x 1/2	120U1141	68	
			ZP31K5E-PFV	HRH031U1LP6	120U1136	68					
			ZP32K3E-PFV	HRH032U1LP6	120U1141	68					
		3	ZP34K5E-PFV	HRH034U1LP6	120U1146	68	HRH038U1LP6	3/4 x 1/2	120U1156	68	
			ZP36K*E-PFV	HRH036U1LP6	120U1151	68					
			ZP38K*E-PFV	HRH038U1LP6	120U1156	68					
		3 1/2	ZP39K5E-PFV	HRH039U1LP6	120U2466	71	HRH040U1LP6	7/8 x 1/2	120U1161	71	
			ZP41K3E-PFV	HRH040U1LP6	120U1161	71					
		4		HRH047U1LP6	120U2362	71	HRH048U1LP6	7/8 x 1/2	120U2582	71	
			ZP49K5E-PFV	HRH048U1LP6	120U2582	71					
		4 1/2	ZP50K3E-PFV	HRH050U1LP6	120U2470	71	HRH050U1LP6	7/8 x 1/2	120U2470	71	
			ZP51K5E-PFV	HRH050U1LP6	120U2470	71					
			ZP54K*E-PFV	HRH054U1LP6	120U1301	82					
		5	ZP57K*E-PFV	HRH056U1LP6	120U1306	82	HLH061T1LP6	7/8 x 1/2	120U2042	82	
			ZP61K5E-PFV	HLH061T1LP6	120U2042	82					
			ZP67KCE-PFV	HLH068T1LP6	120U1311	82					
		208-230/3/60	3	ZP36K*E-TF5	HRH036U2LP6	120U1266	68	HRH040U2LP6 HRH036U2LP6 HRH036U2LP6	7/8 x 1/2	120U1276 120U1266 120U1266	68
				ZP38K*E-TF5	HRH038U2LP6	120U1271	68				
	ZP41K3E-TF5			HRH040U2LP6	120U1276	71					
	4			HRH047U2LP6	120U2855	71	HRH050U2LP6 HRH048U2LP6 HRH048U2LP6	7/8 x 1/2	120U2859 120U2776 120U2776	71	
			ZP49K5E-TF5	HRH048U2LP6	120U2776	71					
			ZP50K3E-TF5	HRH050U2LP6	120U2859	71					
	5 1/2		ZP67KCE-TF5	HLH068T2LC6	120U1481	82	HLH068T2LC6	7/8 x 1/2	120U1481	82	
	6		ZP72KCE-TF5	HLJ072T2LC6	120U1486	82	HLJ072T2LC6	7/8 x 1/2	120U1486	82	
	7		ZP83KCE-TF5	HLJ083T2LC6	120U1491	82	HLJ083T2LC6	7/8 x 1/2	120U1491 <sup>2</sup>	82	
	7 1/2		ZP90KCE-TF5	HCJ090T2LC6	120U2307	100	HCJ090T2LC6	1 1/8 x 7/8	120U2307 <sup>2</sup>	100	
	8	ZP103KCE-TF5	HCJ105T2LC6	120U2327	102	HCJ105T2LC6	1 1/8 x 7/8	120U2327 <sup>2</sup>	102		
	10	ZP120KCE-TF5	HCJ120T2LC6	120U2347	102	HCJ120T2LC6	1 1/8 x 7/8	120U2347 <sup>2</sup>	102		
	460/3/60	3	ZP36K*E-TFD	HRH036U4LP6	120U1201	68	HRH040U4LP6	7/8 x 1/2	120U1211	68	
			ZP38K3E-TFD	HRH038U4LP6	120U1206	68					
			ZP41K3E-TFD	HRH040U4LP6	120U1211	71					
		4	ZP44K*E-TFD	HRH047U4LP6	120U2851	71	HRH050U4LP6	7/8 x 1/2	120U2863	71	
			ZP49K5E-TFD	HRH048U4LP6	120U2772	71					
			ZP50K3E-TFD	HRH050U4LP6	120U2863	71					
		5 1/2	ZP67KCE-TFD	HLH068T4LC6	120U1391	82	HLH068T4LC6	7/8 x 1/2	120U1391	82	
		6	ZP72KCE-TFD	HLJ072T4LC6	120U1396	82	HLJ072T4LC6	7/8 x 1/2	120U1396	82	
7		ZP83KCE-TFD	HLJ083T4LC6	120U1401	82	HLJ083T4LC6	7/8 x 1/2	120U1401 <sup>2</sup>	82		
7 1/2		ZP90K*E-TFD	HCJ090T4LC6	120U2302	100	HCJ090T4LC6	1 1/8 x 7/8	120U2302 <sup>2</sup> See page 48 for Nominal capacitor values and relays.	100		
8	ZP104KCE-TFD	HCJ105T4LC6	120U2322	100	HCJ105T4LC6	1 1/8 x 7/8	120U2322 <sup>2</sup>	100			
10	ZP120K*E-TFD	HCJ120T4LC6	120U2342	100	HCJ120T4LC6	1 1/8 x 7/8	120U2342 <sup>2</sup>	100			

<sup>1</sup>Full range of models (refrigerant, tons and voltage codes) available. Check Coolselector or visit our Online Datasheet Generator at [www.danfoss.com/odsg](http://www.danfoss.com/odsg).

<sup>2</sup>Additional adjustments may be required when replacing a competitor's compressor over 81K Btu/h, as suction and discharge connections may vary significantly. See page 46 for Nominal capacitor values and relays.

**Introduction and Overview**

Danfoss Performer® Universal Scroll Compressors are designed to serve as quick, easy replacements for most 9 to 15 ton commercial air conditioning scroll compressors. These compressors come with a bolt pattern, suction and discharge lines, and performance characteristics that match up directly with some competitors' products.

Select compressor using the product selection table below based on refrigerant, nominal capacity, connection and voltage.



**Nomenclature / Model No.**

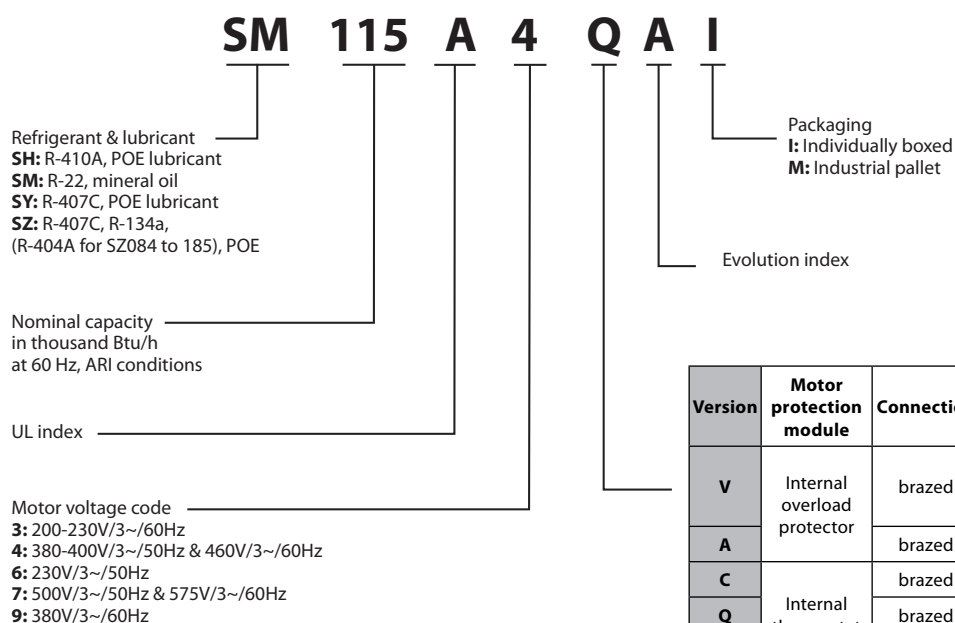

Version	Motor protection module	Connection	Module voltage	Applies to	
V	Internal overload protector	brazed		084-090, 100, 110, 120, 148, 161	
A		brazed		112, 124, 147	
C	Internal thermostat	brazed		115, 125, 160, 175, 185	
Q		brazed			
R		rotolock			
J		brazed	24V DC		
P	Electronic protection module	brazed	24V AC	240, 300	
U		brazed	115V		
X		brazed	230V		
K		rotolock	24V DC		
S		rotolock	24V AC		
W		rotolock	115V		
Y		rotolock	230V		
AF		brazed	24V DC		380 *
AA		brazed	24V AC		
AB		brazed	115/230V		
MA	rotolock	24V AC	380 *		
MB	rotolock	115/230V			
CA	brazed	24V AC			
CB	brazed	115/230V	380 *		
CF	brazed	24V DC			

\* SY380 only available for 400V/3~/50 Hz, SZ380 available for both 400V/3~/50 Hz and 460V/3~/60 Hz

**Product Selection**

Refrigerant	Voltage/ Phase/ Frequency	Tons	Competitor Model Nos.		Danfoss				
					Model No.	Connection type (in. ODF brazed)	Motor protection	Code No. <sup>1</sup>	Weight (lbs)
R-22	200-230/3/60	9 1/3	CSHA-093R CSHS-093R	ZR108KC-TF5 ZR11M3-TWC	SM115S3CC	1 3/8 x 7/8	Internal thermostat, external overload needed	<b>SM115-3QAI</b>	172
		10	CSHA-100R CSHS-100R	ZR125KC-TF5 ZR12M3-TWC	SM125S3CC			<b>SM125-3QAI</b>	172
		12 1/2	CSHA-125R	ZR16M3-TWC	SM160T3CC	1 5/8 x 1 1/8		<b>SM160-3CAI</b>	198
		14	CSHA-140R CSHS-140R		SM175S3CC			<b>SM175-3QAI</b>	220
		15	CSHA-150R CSHS-150R	ZR190KC-TW5	SM185S3CC			<b>SM185-3QAI</b>	220
	460/3/60	9 1/3	CSHA-093K CSHS-093K	ZR108KC-TFD ZR11M3-TWD	SM115S3CC	1 3/8 x 7/8	Internal thermostat, external overload needed	<b>SM115-4QAI</b>	172
		10	CSHA-100K CSHS-100K	ZR125KC-TFD ZR12M3-TWD	SM125S4CC			<b>SM125-4QAI</b>	172
		12 1/2	CSHA-125K	ZR160KC-TW5 ZR16M3-TWD	SM160T4CC	1 5/8 x 1 1/8		<b>SM160-4CAI</b>	198
		14	CSHA-140K CSHS-140K		SM175S4CC			<b>SM175-4QAI</b>	220
		15	CSHA-150K CSHS-150K	ZR190KC-TWD	SM185S4CC			<b>SM185-4QAI</b>	220

<sup>1</sup> Code Nos. ending "QAI" include welded sight glass, oil equalization port, brazed connections, and mounting bracket. Code Nos. ending "CAI" are same as "QAI" but exclude the mounting bracket.

**Product Selection**

Refrigerant	Voltage/ Phase/ Frequency	Tons	Competitor Model Nos.		Danfoss						
					Model No.	Connection type (in. ODF brazed)	Motor protection	Code No.	Weight (lbs)		
R-410A	200-230/3/60	7 1/2	CSHD-089J CSHD-092J	ZP90KCE-TF5 ZP91KCE-TF5	SH090A3ALC	1 1/8 x 7/8	Internal overload protector	<b>120H0001</b>	128		
		8 3/4	CSHD-105J	ZP103KCE-TF5	SH105A3ALC	1 3/8 x 7/8		<b>120H0209</b>	142		
		10	CSHD-125J	ZP120KCE-TF5	SH120A3ALC			<b>120H0011</b>	142		
		11 2/3	CSHD-142J	ZP137KCE-TF5	SH140A3ALC			<b>120H0199</b>	148		
		13 1/2	CSHD-161J	ZP154KCE-TW5	SH161A3ALC			<b>120H0021</b>	152		
		14 1/2			SH175A3ALC			<b>120H0872</b>	159		
		15		ZP182KCE-TW5	SH184A3ALC			<b>120H0359</b>	159		
		20			SH240A3AAE SH240A3ABE			1 5/8 x 1 1/8	24V ac 115/230V	<b>120H0289</b> <b>120H0297</b>	238
		25		ZP295KCE-TWC	SH295A3AAE SH295A3ABE				24V ac 115/230V	<b>120H0851</b> <b>120H0853</b>	245
	460/3/60	7 1/2	CSHD-089K CSHD-092K	ZP90KCE-TFD	SH090A4ALC	1 1/8 x 7/8	Internal overload protector	<b>120H0003</b>	128		
		8 3/4	CSHD-105K	ZP103KCE-TFD	SH105A4ALC	1 3/8 x 7/8		<b>120H0211</b>	142		
		10	CSHD-125K	ZP120KCE-TFD	SH120A4ALC			<b>120H0013</b>	142		
		11 2/3	CSHD-142K	ZP137KCE-TF5	SH140A4ALC			<b>120H0201</b>	148		
		13 1/2	CSHD-161K	ZP154KCE-TF5	SH161A4ALC			<b>120H0023</b>	152		
		14 1/2			SH175A4ALC			<b>120H0870</b>	159		
		15		ZP182KCE-TF5	SH184A4ALC			<b>120H0361</b>	159		
		20			SH240A4AAE SH240A4ABE			1 5/8 x 1 1/8	24V ac 115/230V	<b>120H0291</b> <b>120H0299</b>	238
		25		ZP295KCE-TWC	SH295A4AAE SH295A4ABE				24V ac 115/230V	<b>120H0825</b> <b>120H0827</b>	245
30		ZP385KCE-TWC	SH380A4AAE SH380A4ABE	24V ac 115/230V	<b>120H0253</b> <b>120H0255</b>	358					

For more information on Danfoss Compressors, please check Coolselector or visit our Online Datasheet Generator at [www.danfoss.com/odsg](http://www.danfoss.com/odsg).



**Quick Select Guide**
**Nominal Capacitor Values and Relays**

Models	Start capacitor (uF)	Start capacitor voltage (V)	Run capacitor (uF)	Run capacitor voltage (V)	Start relay
MT/MTZ18 JA-1	100	330	25	440	3ARR3J4A4/ RVA6AMKL
MT/MTZ22 JC-1	100	330	45	440	
MT/MTZ28 JE-1	135	330	50	440	
MT/MTZ32 JF-1	100	330	45	440	
MT/MTZ36 JG-1	100	330	45	440	
MT/MTZ40 JH-1	100	330	55	440	
MT/MTZ44 HJ-1	135	330	45	440	
MT/MTZ50 HK-1	135	330	45	440	
MT/MTZ56 HL-1	200	330	55	440	
MT/MTZ64 HM-1	235	330	55	440	
NTZ048A1LR1A	100	330	25	440	
NTZ068A1LR1A	135	330	50	440	
NTZ096A1LR1A	135	330	45	440	
NTZ108A1LR1A	135	330	45	440	
NTZ136A1LR1A	135	330	45	440	
HRM025-034	145-175	250	45	370	3ARR3*3M*
HRM038	88-108	330	55	370	3ARR3*3L*
HRM040-045	88-108	330	60	370	3ARR3*3L*
HRM047	88-108	250	60	370	3ARR3*3L*
HRM048	161-193	250	60	370	3ARR3*3L*
HRM051-054	161-193	250	70	370	3ARR3*3L*
HRM058T1-060T1	88-108	250	55	440	3ARR3*25S*
HRM058U1-060U1, HLM068-081	189-227	330	80	370	3ARR3*3L*
HRH031	145-175	250	45	370	3ARR3*3M*
HRH032-034	88-108	330	50	370	3ARR3*3L*
HRH036	88-108	330	55	370	3ARR3*3AL*
HRH038-040	88-108	330	60	370	3ARR3*3L*
HRH041-051	161-193	250	70	370	3ARR3*3L*
HRH054-056, HLH068, HLJ072-083	189-227	330	80	370	3ARR3*3L*

**Introduction and Overview** The most commonly replaced spare parts and accessories for the products included in this Quick Select guide are outlined in this section. For additional accessories please consult individual product Technical brochures or contact Danfoss.

**Product Selection**

Product, Type	Description	Code No.	Type applied to
Thermostatic Expansion Valves, Types TUA/TUAE	Bulb strap	068U1705	all
	Metal Gasket (24 pcs)	068U0015	all
	Filter for orifices 0-4 (24 pcs)	068U1706	all
	Filter for orifices 5-9 (24 pcs)	068U0016	all
Thermostatic Expansion Valves, Type TR6	Bulb strap	068U1705	all
Thermostatic Expansion Valves, Type TGE	Bulb strap	068U1705	all
Pressure Controlled Water Valves, Types WVFX	Valve disc kit; valve disc, (2) o-rings, (8) screws, (2) diaphragms, grease and key	003N4006	WVFX 10, 15
	Valve disc kit; valve disc, (2) o-rings, (8) screws, (2) diaphragms, grease and key	003N4007	WVFX 20
	Valve disc kit; valve disc, (2) o-rings, (8) screws, (2) diaphragms, grease and key	003N4008	WVFX 25
	Capillary tube; 39" with 1/4" flare coupling nuts on each end	060-017166	WVFX with 1/4" M flare
	Bracket	003N0388	all
Solenoid Valves, Type EVR	Permanent magnet coil for servicing and testing	018F0091	all
	Service kit; o-ring, (4) screws, armature assembly, rubber gasket	032F0181	EVR 2, 3
	Service kit; diaphragm, o-ring for armature tube, (4) screws T20, (4) screws T15, armature assembly, rubber gasket, o-ring for steel cover, square gasket for steel cover, support ring	032F8166	EVR 6
	Service kit; diaphragm assembly, o-ring, (4) screws, armature assembly, rubber gasket	032F0185	EVR 10
	Service kit; diaphragm assembly, o-ring, (4) screws, armature assembly, rubber gasket, flange gasket	032F0187	EVR 15, 18
	Service kit; diaphragm assembly, o-ring, (4) screws, armature assembly, compression spring, rubber gasket	032F0189	EVR 20, 22
	Manual spindle	032F0193	EVR 20, 22
	Piston service kit; (2) o-ring, spring, piston assembly, plastic block, rubber gasket, piston ring	032F3236	EVR 25
	Pilot service kit; armature tube assembly, armature, (2) Al. gaskets, orifice, o-ring	042H0161	EVR 25
	Seal kit; (2) Al. gaskets, (3) o-rings, (2) rubber gaskets	032F3235	EVR 25
	Piston service kit; (5) o-rings, Al. gasket, piston assembly, plastic block, gasket, piston ring, spring	042H0172	EVR 32
	Pilot service kit; (2) Al. gaskets, o-ring, orifice, armature tube assembly, armature	042H0165	EVR 32
	Seal kit; (4) o-rings, (2) Al. gaskets, gasket	042H0160	EVR 32
	Piston seal kit; (5) o-rings, Al. gasket, piston assembly, plastic block, gasket, piston ring, spring	042H0173	EVR 40
Seal kit; (5) o-rings, (2) Al. gaskets, gasket	042H0160	EVR 40	
Pressure and Temperature Controls, Type KPU	Capillary tube; 39" with 1/4" flare coupling nuts on each end	060-017166	KPU pressure with 1/4" M flare
Pressure Regulators, Types KVP/KVR/KVL/KVC/CPCE	Seal kit; contains cap and rubber gasket	034L0201	KVP 12, 15, 22 KVR 12, 15, 22 all KVC, CPCE
	Seal kit; contains cap and rubber gasket	034L0202	KVP 28, 35 KVR 28, 35
	Schrader valve	034L0006	all KVP, KVR
	Seal kit for schrader valve	034L0203	all KVP, KVR

**Quick Select Guide**
**Spare Parts and Accessories**

Product, Type	Description	Code No.	Type applied to
Condensing Units	Compressors, fan motors, fan blades, relays, capacitors	<b>various - contact Danfoss</b>	various
	Enclosure - E1	<b>119-6040</b>	1/6 to 5/8 hp
	Enclosure - E2	<b>119-6041</b>	5/8 to 2 hp
	Enclosure - E3	<b>119-6042</b>	2 1/2 to 3 hp
	Enclosure - E4	<b>119-6043</b>	4 hp
	Enclosure - E5	<b>119-6044</b>	5 to 7 hp
	Enclosure - E6	<b>119-6045</b>	9 to 13 1/2 hp
Reciprocating Compressors, Type MT/MTZ	Belt type crankcase heater; 54W, 230V	<b>7773106</b>	MT(Z) 018-040
	Belt type crankcase heater; 65W, 110V	<b>7773109</b>	MT(Z) 044-081
	Belt type crankcase heater; 65W, 230V	<b>7773107</b>	
	Belt type crankcase heater; 65W, 400V	<b>7773117</b>	
	Belt type crankcase heater; 65W, 460V	<b>120Z0466</b>	
	Belt type crankcase heater; 75W, 110V	<b>7773110</b>	MT(Z) 100-160
	Belt type crankcase heater; 75W, 230V	<b>7773108</b>	
	Belt type crankcase heater; 75W, 400V	<b>7773118</b>	
	Belt type crankcase heater; 75W, 460V	<b>120Z0464</b>	
	PTC heater	<b>PTC</b>	all
	Mounting kit - 1&2 cylinder compressors	<b>8156001</b>	MT(Z) 18-81
	Mounting kit - 4 cylinder compressors	<b>8156007</b>	MT(Z) 100-160
	Mineral oil, 160P; 2 liter can	<b>7754001</b>	all MT
	Mineral oil, 160P; 5 liter can	<b>7754002</b>	all MT
	POE lubricant, 160PZ; 1 liter can	<b>7754019</b>	all MTZ
	Oil sight glass and gasket	<b>8156019</b>	all
	Terminal box; include cover and clamp	<b>8156134</b>	MT(Z) 18-44
Terminal box; include cover and clamp	<b>8156135</b>	MT(Z) 50-160	
Blue spray paint	<b>8154001</b>	all	
Scroll Compressors, Types HRM/HLM/HCM/HRH/HLH/HLJ/H CJ	Wire harness; 5 feet, for 200-230V scroll compressor	<b>120Z5056</b>	all
	Wire harness; 5 feet, for 380-575V scroll compressor	<b>120Z5057</b>	all
	Belt type crankcase heater; 40W, 230V	<b>120Z0055</b>	HRM032-047, HRH031-040
	Belt type crankcase heater; 40W, 400V	<b>120Z0056</b>	
	Belt type crankcase heater; 50W, 230V	<b>120Z0057</b>	HRM048-060, HLM068-075, HRH044-056, HLH061-068, HLJ072-075
	Belt type crankcase heater; 50W, 400V	<b>120Z0058</b>	
	Belt type crankcase heater; 65W, 230V	<b>120Z0059</b>	HLM078-081, HCM094-120, HLJ083, HCJ090-120
	Belt type crankcase heater; 65W, 400V	<b>120Z0060</b>	
	Belt type crankcase heater; 70W, 230V	<b>120Z5040</b>	
	Belt type crankcase heater; 70W, 400/440V	<b>120Z5041</b>	
	POE lubricant ; 1 liter can	<b>120Z5033</b>	HRH, HLH except HLH061
	PVE lubricant, 210HV (FVC68D); 1 liter can	<b>120Z5034</b>	HRH, HLH, HLJ, HCJ
	Mounting kit for 1 compressor; 4 grommets, 4 sleeves, 4 bolts, 4 washers	<b>120Z5005</b>	all

**Quick Select Guide**
**Spare Parts and Accessories**

Product, Type	Description	Code No.	Type applied to
Scroll Compressors, Type SM/SH	Solder sleeve adapter set (1 3/4" rotolock, 1 1/8" ODF), (1 1/4" rotolock, 7/8" ODF)	<b>120Z0125</b>	SH090
	Solder sleeve adapter set (1 3/4" rotolock, 1 3/8" ODF), (1 1/4" rotolock, 7/8" ODF) <i>*diameter restrictor</i>	<b>7765006</b>	SM115, 125, 160 SH105, 120, 140, 161, 184
	Solder sleeve adapter set (1 3/4" rotolock, 1 3/8" ODF), (1 1/4" rotolock, 7/8" ODF)	<b>120Z0405</b>	SM115, 160 SH105, 120, 140, 161, 184
	Solder sleeve adapter set (2 1/4" rotolock, 1 5/8" ODF), (1 3/4" rotolock, 7/8" ODF)	<b>7765028</b>	SM175, 185 SH240, 380
	Belt type crankcase heater; 65W, 460V	<b>120Z0466</b>	SM115, 125, 160
	Belt type crankcase heater; 65W, 110V	<b>7773109</b>	
	Belt type crankcase heater; 65W, 230V	<b>7773107</b>	
	Belt type crankcase heater; 65W, 400V	<b>7773117</b>	
	Belt type crankcase heater; 65W, 400V	<b>120Z0039</b>	SM175, 185
	Belt type crankcase heater; 75W, 110V	<b>7773110</b>	
	Belt type crankcase heater; 75W, 230V	<b>7773108</b>	
	Belt type crankcase heater; 75W, 400V	<b>7773118</b>	
	Belt type crankcase heater; 75W, 460V	<b>120Z0464</b>	
	Motor protection module, 24V DC	<b>120Z0141</b>	SM115, 125, 160, 185 SH180
	Motor protection module, 24V AC	<b>8169020</b>	SM115, 125, 160, 185 SH180
	Motor protection module, 230V	<b>8169021</b>	SM115, 125, 160, 185 SH180
	Motor protection module, 24V DC	<b>120Z0140</b>	SH240, 295, 380
	Motor protection module, 24V AC	<b>8169015</b>	SH240, 295, 380
	Motor protection module, 115/230V	<b>8169016</b>	SH240, 295, 380
	Service kit for terminal box; includes cover, clamp, T block connector	<b>8156135</b>	SH090, 105, 120, 140, 161
	Terminal box, including cover	<b>8156139</b>	SM115, 125, 160, 175, 185
	Terminal box cover	<b>120Z0413</b>	SH140-3, 161-3, 184, 175
	Terminal box, including cover	<b>120Z0458</b>	SH240, 295, 380
	Mounting kit for 1 compressor; 4 grommets, 4 sleeves, 4 bolts, 4 washers	<b>8156138</b>	SM115-185
	Mounting kit for 1 compressor; 4 grommets, 4 sleeves, 4 bolts, 4 washers	<b>120Z0066</b>	SH090, 105, 120, 140, 161, 175, 184
	Mounting kit for 1 compressor; 4 rigid grommets, 4 sleeves, 4 bolts, 4 washers	<b>7777045</b>	SH240, 295, 380
	Mineral oil, 160P; 2 liter can	<b>7754001</b>	all SM
	Mineral oil, 160P; 5 liter can	<b>7754002</b>	all SM
	Blue spray paint	<b>8154001</b>	all
	Oil equalization adaptor. To connect 7/8" tube on 22mm oil sight glass connection.; includes (1) 22mm to 7/8", (2) gaskets.	<b>120Z0164</b>	all SM, SH
Oil equalization adaptor. To connect 1/2" tube on 22mm oil sight glass connection.; includes (1) 22mm to 1/2", (2) gaskets.	<b>120Z0165</b>	all SM, SH	
Oil equalization adaptor kit for trio mounting; oil fittings, gasket and adaptors (copper pipes not included).	<b>7773112</b>	SM 160, 185	





# The Danfoss product range for the refrigeration and air conditioning industry

Danfoss Refrigeration & Air Conditioning is a worldwide manufacturer with a leading position in industrial, commercial and supermarket refrigeration as well as air conditioning and climate solutions.

We focus on our core business of making quality products, components and systems that enhance performance and reduce total life cycle costs – the key to major savings.

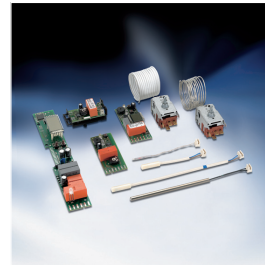

We offer a single source for one of the widest ranges of innovative refrigeration and air conditioning components and systems in the world. And, we back technical solutions with business solutions to help your company reduce costs, streamline processes and achieve your business goals.

<http://NAMAaftermarket.danfoss.com>

Danfoss can accept no responsibility for possible errors in catalogues, brochures and other printed material. Danfoss reserves the right to alter its products without notice. This also applies to products already on order provided that such alterations can be made without consequential changes being necessary in specifications already agreed. All trademarks in this material are property of the respective companies. Danfoss and the Danfoss logotype are trademarks of Danfoss A/S. All rights reserved.