

BlueDiamond®

condensate removal pumps

MicroBlue®

With no additional silencing accessories required, not only is the MicroBlue® a silent running pump but it can also be mounted in any orientation whilst operating both wet and dry continuously. The MicroBlue® is a dual voltage pump which uses proven thermistor level sensing technology to remove the risk of stuck or sunken float switches.



3 year warranty

Performance

Max flow	Max head	Max suction lift
1.3 gallons/hour	16 foot	6 foot

***Dual Voltage- 110V and 230V**

Dimensions (")

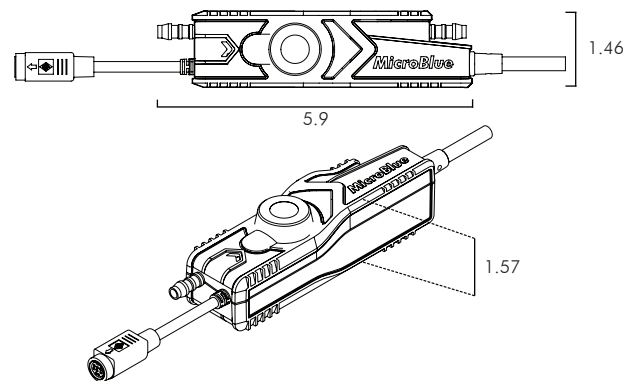

Sensing Options

MicroBlue® pump available with the following option:

Reservoir sensor

X85-003 (HLA PACK)



Installation Options

The MicroBlue® can be mounted in any orientation up to 6ft away from the air conditioning unit.

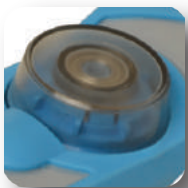
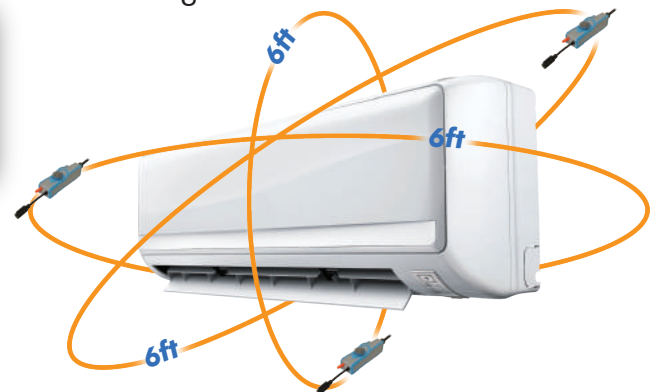

Unique patented pumping principle



Indicator



DIN plug

Blue Diamond
Pumps Inc

+1 770 831 1122

info@bluediamondpumps.com

www.bluediamondpumps.com