

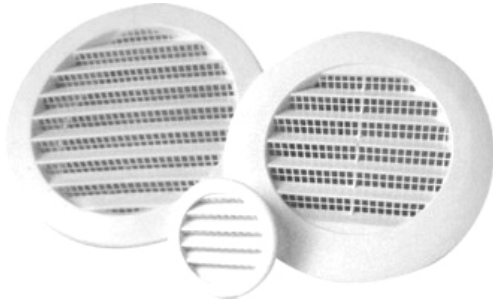

Builder's Best, Inc.
 201 Broiles Drive
 Jacksonville, TX 75766
 888-368-7233
 fax: 800-259-8368
 www.BuildersBest.com

SOFFIT VENTS



PART NUMBERS

Diameter	Part #	Qty	Package	Free Area
2"	111852	50	bulk	1.1 sq.in
4"	111869	16	bulk	4.0 sq.in
5"	111870	50	bulk	6.4 sq.in
6"	111871	12	bulk	10.3 sq.in



PRODUCT SPECIFICATIONS

- Extra long collar for better duct connection
- Molded in mesh screen
- UV Stabilized Polymer resin
- Secure friction fit

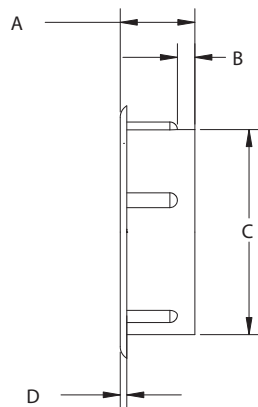
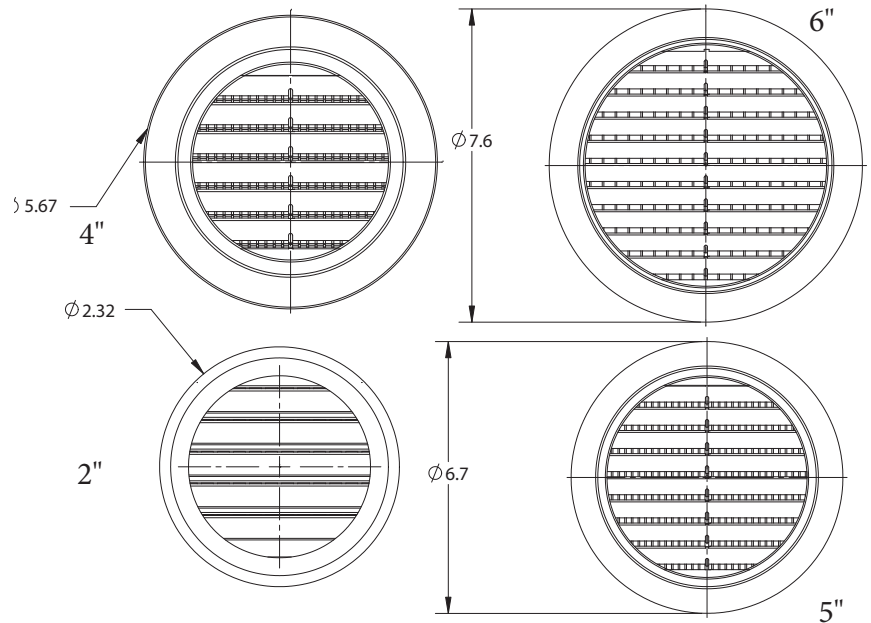

Diameter	A	B	C	D
2"	.68	.16	1.88	.06
4"	1.71		3.91	
5"	1.5		4.98	.1
6"	1.49		5.96	.13

LABELS



Builder's Best is an
 Authorized Primex Distribution Partner
 Primex is Made in Canada

WARRANTY

Manufacturer assumes no responsibility for failure due to improper installation.
 All specifications and designs are subject to change without notice and without incurring liability.

WARRANTY EXCLUSION AND DISCLAIMER Seller specifically excludes, and hereby disclaims any express representation or express warranty of any kind with respect to the goods ordered hereunder. All implied warranties, including without limitation merchantability or fitness for a particular purpose or arising from a course of dealing or usage or trade shall expire and cease 45 days after date of delivery. Seller shall not be liable to buyer or any third party for any special, secondary, incidental, or consequential damages however arising. Nothing in this provision shall invalidate or restrict any right or remedy otherwise available under state or federal law. Materials and specifications subject to change without notice.

Soffit Vents V2 9/10/16