



Helical Oil Separators: The helical oil separator features a centrifugal flow path achieving approximately 99. x% efficiency of oil separation with low pressure drop. Testing by an independent laboratory found that only .006% oil by volume was being discharged into the system after leaving a helical oil separator.

How the Helical Oil Separator functions: Upon separator entry, refrigerant gas containing oil in aerosol form, encounters the leading edge of the helical flighting. The gas/oil mixture is centrifugally forced along the spiral path of the helix, causing heavier oil particles to spin to the perimeter, where impingement with a screen layer occurs. The screen layer serves dual functions as an oil stripping and draining medium. Separated oil flows downward along the boundary of the shell through a baffle and into the oil collection area at the bottom of the separator. The specially engineered baffle isolates the oil collection area and eliminates oil reentrainment by preventing turbulence. Virtually oil-free refrigerant gas exits through a fitting just below the lower edge of the helical flighting. A float activated oil return valve allows the captured oil to return to the crankcase or oil reservoir, thereby completing the oil circuit. Our Patented Mechanical Design offers high oil separation efficiency, plus the following advantages not found in a Coalescing Oil Separator:

- Low pressure drop throughout the entire range of velocities found in a refrigeration system.
- No clogging elements because of too much oil in the system.
- No oil blow-out at start-up from oil left in a coalescing element.
- Oil can be drained from the separator when necessary through a 1/8" NPT fitting at the bottom of the separator.



How the Conventional Oil Separator functions: Refrigerant gas from the compressor containing oil in aerosol form enters the separator and passes through the inlet baffling. As it passes through the inlet screen, the fine particles collide with one another and form heavier particles that impinge on the surface of the shell wall. The gas then passes through the outlet screen where there is a final separation. The oil free gas escapes through the outlet fitting and goes to the condenser. The separated oil drips to the bottom of the separator where a float operated needle valve returns the oil to the crankcase or oil reservoir in the same way as the Helical Oil Separator. Selecting the size of an Oil Separator: Although Oil Separator catalogs show capacity in tons or horsepower, the actual tonnage or B.T.U. capacity of a system may vary widely from the horsepower size of the compressor.



The selection of an oil separator should be completed using the methodology shown on page 4. It is important this process not be ignored as it will affect the oil separation efficiency. The DCFM and tonnage ratings have been developed around internal testing to allow wide enough ranges where the oil separation efficiency is optimal and pressure drop is no greater than 0.5 psi.

# HELICAL OIL SEPARATORS

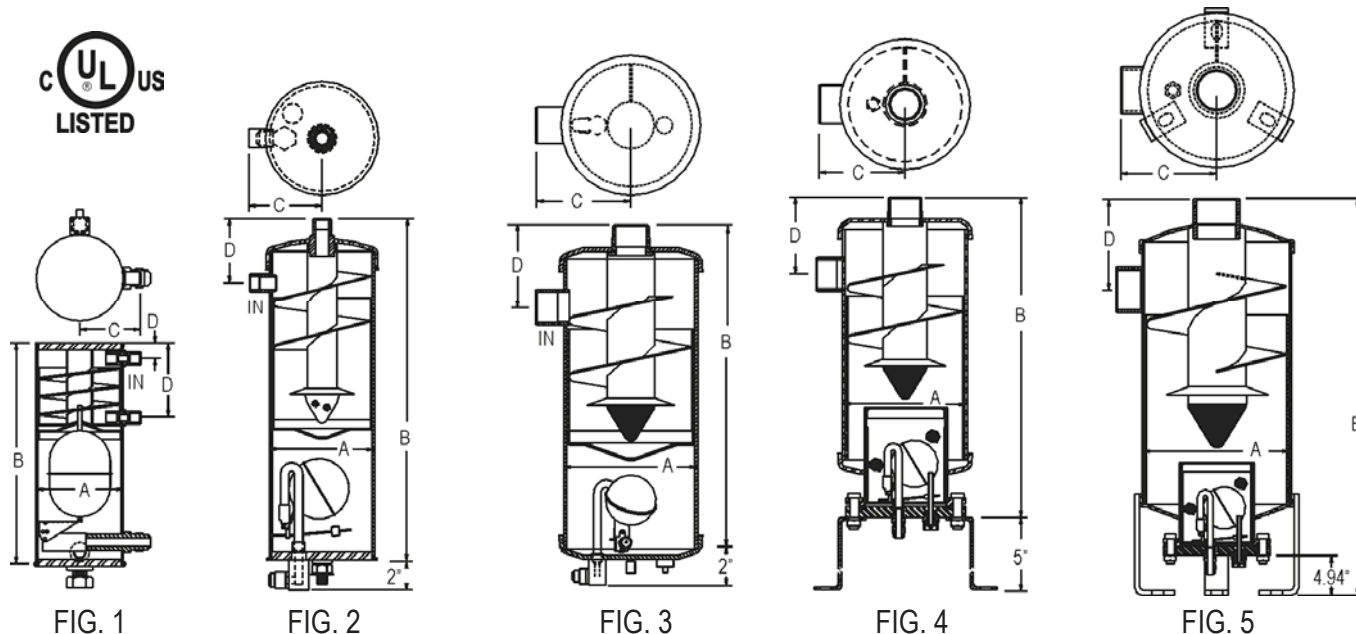

Catalog Number	Fig. No.	Size Conn. ODS	Dimensions in Inches					Capacity in Tons of Ref. at Evap. Temp.						Nom. DCFM	Pre-Charge Oil (oz)
			A	B	C	D		R-134a		R-22		R-404a/R-507			
						-40°F	+40°F	-40°F	+40°F	-40°F	+40°F				
S-5180	1	1/4"	2.5	6.38	1.75	0.44	2.12	0.40	0.50	0.55	0.60	0.50	0.60	0.5	14
S-5181	1	3/8"	2.5	7.5	1.75	0.5	3.25	0.90	1.00	1.20	1.40	1.00	1.20	1.1	14
S-5182	2	1/2"	4	13	2.75	2.44		1.30	1.50	1.80	2.00	1.50	1.90	1.7	14
S-5185	2	5/8"	4	15	2.75	2.5		2.40	2.90	3.60	4.00	3.00	3.70	3.4	14
S-5187	2	7/8"	4	17	3	2.94		4.70	5.70	6.80	7.60	5.70	7.00	6.5	14
S-5188	2	1 1/8"	4	19	3	3.06		8.00	9.50	11.40	12.70	9.30	11.50	10.7	14
S-5190	3	1 3/8"	6	15	4.25	3.69		11.60	13.90	16.40	18.40	13.60	16.40	15.5	40
S-5192	3	1 5/8"	6	17	4.25	3.95		16.40	19.10	22.90	25.60	18.60	22.90	21.4	40
S-5194	3	2 1/8"	6	17	4.38	4.19		24.90	29.40	35.40	39.10	28.60	35.40	33.0	40
S-5290	4	1 3/8"	6	15	4.25	3.69		11.60	13.90	16.40	18.40	13.60	16.40	15.5	25
S-5292	4	1 5/8"	6	17	4.25	3.95		16.40	19.10	22.90	25.60	18.60	22.90	21.4	25
S-5294	4	2 1/8"	6	17	4.38	4.19		24.90	29.40	35.40	39.10	28.60	35.40	33.0	25
S-5202	5	2 1/8"	8	24	5.38	5.06		29.40	35.00	41.80	46.60	34.30	42.10	39.2	25
S-5203	5	2 5/8"	10	27	6.5	5.63		48.60	58.10	70.10	78.10	58.10	71.60	66.6	25
S-5204	5	3 1/8"	12	30	7.75	6.45		71.60	85.10	102.60	114.60	85.10	105.10	97.6	25

DCFm & Tonnage Ratings revised for optimal oil separation and minimal pressure drop. Replacement components on page 9.

U.S. patents #5,113,671 #5,404,730 #5,271,245; Mexico 173552; Denmark, France, Great Britain, Italy 0 487 959; Germany P69106849.6-08; Taiwan UM-74863; & other U.S. & foreign patents pending. Standard 3/8" flare oil return connection & 1/8" FPT oil drain; 3/8" O.D.S. oil return connection available by ordering an "X" suffix (i.e. S-5292X). All the capacities shown are based on 105°F condensing. See page 4 for sizing instructions.

# GUARDIAN-SEPARATOR

## Reservoir



The captured oil is retained in the oil reservoir in the lower portion of the oil separator. Install the Roto Loc Valve Cat. No. 2-030-130 (which is provided) to the Roto Loc Spud on the bottom of the Oil Separator/Reservoir. Connect the 3/8" return line from the valve directly to the Electro-Mech Regulators. This valve is the distribution valve to the OIL LEVEL REGULATORS (open position). To add or remove oil from the OIL RESERVOIR, close the valve and use the 1/4" flare connection on the side of the valve. Open the valve after service. Oil Level Regulators are activated by the lowering of the oil level in the compressor crankcase. The oil is fed from the Oil Reservoir to the Electro-Mechanical Oil Regulator and into the crankcase until the set oil level is attained.

The heart of any oil control system is a high efficiency Helical Oil Separator. For parallel compressor systems application we recommend our S-5300 Series Helical Oil Separator/Reservoir combinations.

### How it Works:

The Helical Oil Separator features a centrifugal flow path achieving approximately 99% efficiency of oil separation with low pressure drop. Testing by an independent laboratory found that only .006% oil by volume was being discharged into the system after leaving a helical oil separator. Virtually oil-free refrigerant gas exists through a fitting just below the lower edge of the helical flighting.

For use with S-9030 Electro-Mechanical Regulators and Optronic Sensors

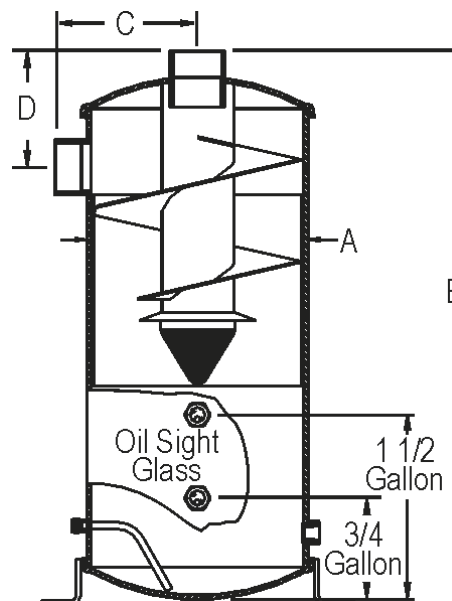

Catalog Number	Size Conn. ODS	Dimensions in Inches				Capacity in Tons of Ref. at Evap. Temp. (Nominal)						Nom. DCFM	Pre-Charge Oil (oz)
		A	B	C	D	R-134a		R-22		R-404a/R-507			
						-40°F	+40°F	-40°F	+40°F	-40°F	+40°F		
S-5390	1 3/8"	6	33.5	4.25	3.69	11.60	13.90	16.40	18.40	13.60	16.40	15.5	2
S-5392	1 5/8"	6	33.5	4.25	3.95	16.40	19.10	22.90	25.60	18.60	22.90	21.4	2
S-5394	2 1/8"	6	33.5	4.38	4.19	24.90	29.40	35.40	39.10	28.60	35.40	33	2
S-5302	2 1/8"	8	25.5	5.38	5.06	29.40	35.00	41.80	46.60	34.30	42.10	39.2	2
S-5303	2 5/8"	10	30	6.5	5.63	48.60	58.10	70.10	78.10	58.10	71.60	66.7	2
S-5304	3 1/8"	12	30	7.75	6.45	71.60	85.10	102.60	114.60	85.10	105.10	97.6	2

U.S. patents #5,113,671 #5,404,730 #5,271,245; Mexico 173552; Denmark, France, Great Britain, Italy 0 487 959; Germany P69106849.6-08; Taiwan UM-74863; & other U.S. & foreign patents pending. Standard 3/8" flare oil return connection & 1/2" FPT low oil return connection & 1/2" FPT low level alarm connection. All the capacities shown are based on 105°F condensing. See page 4 for sizing instructions.



## Calculating Separator DCFM

Correct oil separator sizing is essential for proper oil separation and minimal pressure drop across the separator. The following example will demonstrate how to select an oil separator based on four primary system conditions and using the DCFM charts on the following page. It is important to determine the discharge cubic feet per minute of the hot gas flow approaching the separator. The DCFM is a theoretical sizing value used to predict which model will offer the best oil separation efficiency for a set of conditions. Henry offers three different designs, helical, conventional screen, and coalescing.

### Sizing Notes

*Helical Separators:* This design relies on adequate gas velocities to allow for oil extraction from the hot gas so sizing according to the DCFM rating is important. Page 6 shows the min/max ratings allowed for sufficient separation and low pressure drop. When sized correctly the helical models will separate 95-99% of the oil from the hot gas.

*Conventional Screen:* This oil separator should not be undersized (calculated DCFM greater than 125% of nominal), which would cause higher gas velocities to pass through the inlet/outlet screens. Higher flow velocities may cause pre-mature failure of the screens.

### Selection Example

#### Primary Conditions

- Evaporating Temperature, -40°F
- Condensing Temperature, 105°F
- Tons of Refrigeration or Air Conditioning, 20 Tons

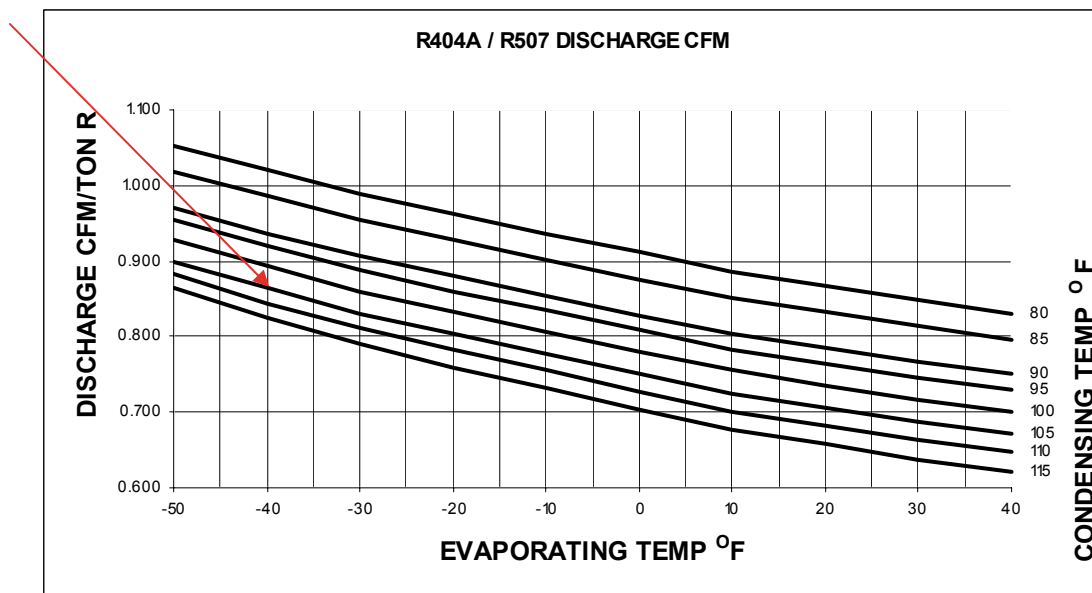

Following the 105°F condensing temp line from the right side to the vertical line at -40°F corresponds to ~0.87 on the DCFM/Ton axis. This factor is multiplied by the Tons of refrigeration (0.86 x 20) to yield 17.2 DCFM.

## Calculating Separator DCFM Continued

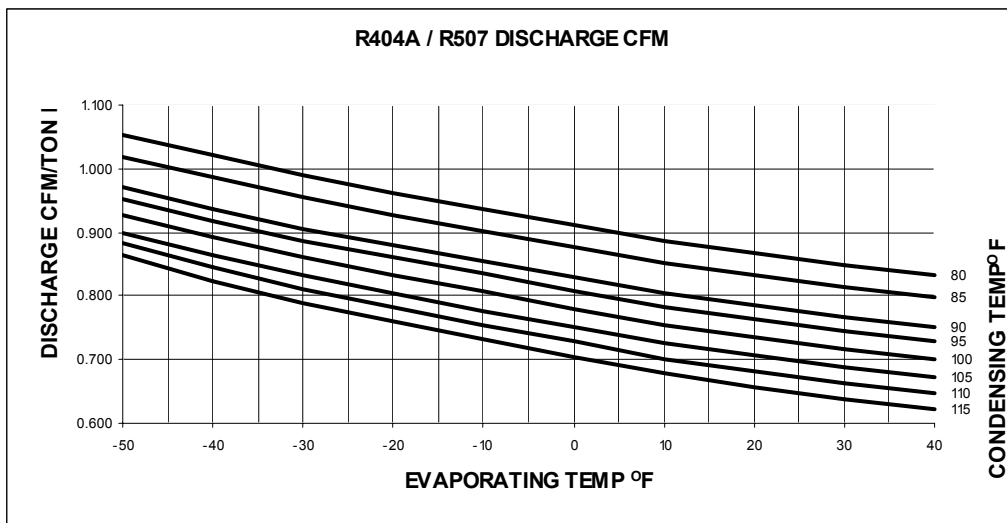
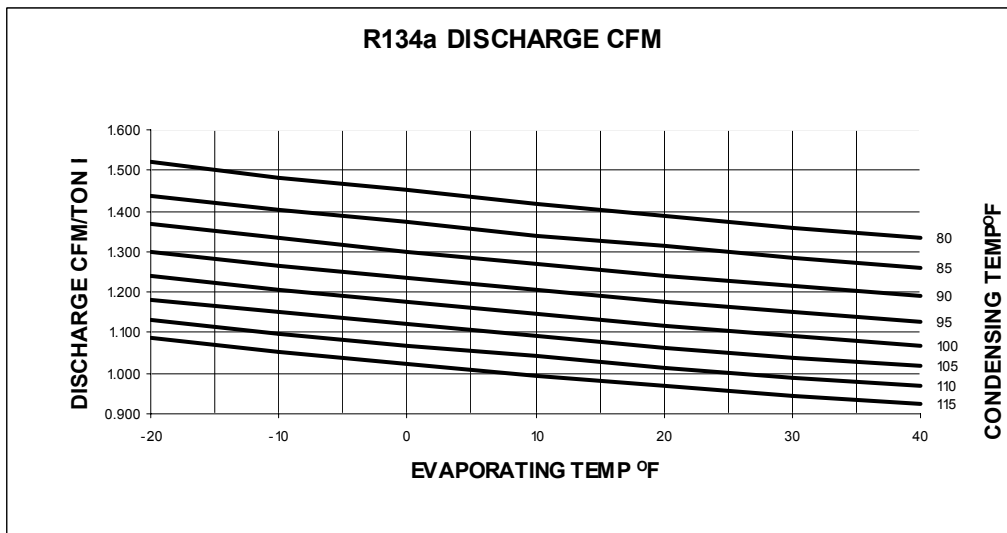
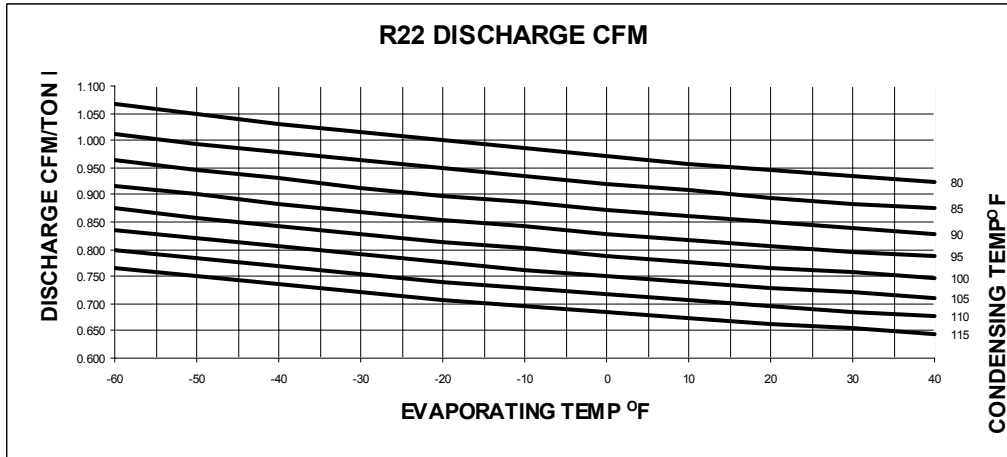

# OIL SEPARATORS

## Sizing Charts



Min/Max DCFMs shown below for various common refrigerants at specific conditions. For other conditions and refrigerants please consult the factory.

Catalog Number	R404a, -40F Evap. 105F Cond.				R22, 40F Evap. 105F Cond.			
	MINIMUM DCFM	MAXIMUM DCFM	MINIMUM TONS	MAXIMUM TONS	MINIMUM DCFM	MAXIMUM DCFM	MINIMUM TONS	MAXIMUM TONS
S-5180	0.46	0.55	0.41	0.49	0.45	0.63	0.49	0.69
S-5181	0.60	1.58	0.54	1.41	0.61	1.84	0.66	2
S-5182	1.17	2.18	1.05	1.95	1.15	2.53	1.25	2.75
S-5185	3.0	3.6	2.7	3.2	3.0	4.2	3.3	4.5
S-5187	4.6	8.1	4.1	7.2	4.5	9.5	4.9	10.3
S-5188	6.0	14.8	5.4	13.2	6.1	17.3	6.6	18.8
S-5190	8.5	21.9	7.6	19.6	8.4	25.4	9.1	27.6
S-5192	10.7	30.9	9.6	27.6	10.7	36.4	11.6	39.6
S-5194	16.9	47.1	15.1	42.1	16.6	55.3	18.1	60.1
S-5290	8.5	21.9	7.6	19.6	8.4	25.4	9.1	27.6
S-5292	10.7	30.9	9.6	27.6	10.7	36.4	11.6	39.6
S-5294	16.9	47.1	15.1	42.1	16.6	55.3	18.1	60.1
*S-5202	21.9	54.6	19.6	48.9	22.2	63.6	24.1	69.1
*S-5203	46.0	84.0	41.1	75.1	45.2	98.5	49.1	107.1
*S-5204	70.6	119.8	63.1	107.1	70.9	139.9	77.1	152.1

Catalog Number	R134a, 40F Evap. 105F Cond.				R407c, 40F Evap. 105F Cond.			
	MINIMUM DCFM	MAXIMUM DCFM	MINIMUM TONS	MAXIMUM TONS	MINIMUM DCFM	MAXIMUM DCFM	MINIMUM TONS	MAXIMUM TONS
S-5180	0.46	0.76	0.33	0.54	0.46	0.58	0.44	0.56
S-5181	0.60	2.19	0.43	1.56	0.60	1.68	0.58	1.62
S-5182	1.19	3.01	0.85	2.15	1.14	2.34	1.1	2.25
S-5185	3.01	4.98	2.15	3.55	3.02	3.85	2.9	3.7
S-5187	4.63	11.22	3.3	8	4.58	8.63	4.4	8.3
S-5188	6.03	20.61	4.3	14.7	6.03	15.81	5.8	15.2
S-5190	8.55	30.29	6.1	21.6	8.42	22.98	8.1	22.1
S-5192	10.66	42.91	7.6	30.6	10.50	33.38	10.1	32.1
S-5194	16.97	65.35	12.1	46.6	17.26	50.80	16.6	48.85
S-5290	8.55	30.29	6.1	21.6	8.42	22.98	8.1	22.1
S-5292	10.66	42.91	7.6	30.6	10.50	33.38	10.1	32.1
S-5294	16.97	65.35	12.1	46.6	17.26	50.80	16.6	48.85
*S-5202	22.23	75.86	15.85	54.1	21.94	57.82	21.1	55.6
*S-5203	45.01	117.93	32.1	84.1	45.86	90.58	44.1	87.1
*S-5204	71.66	167.01	51.1	119.1	70.82	128.02	68.1	123.1

- \*Rates also apply to Guardian Separator/Reservoir S-53\*\* types.
- *Minimum DCFM & tons should be met in order to ensure proper oil separation.*
- **Maximum DCFM & tons should not be exceeded due to pressure drop will become greater than 0.5 psi.**



# CONVENTIONAL

## Oil Separators



### Features:

- **Connections** are nickel plated steel
- **Oil flow rate @ 175 PSI** differential .80 gal/min.
- **3/8" flare oil return connection**
- **All capacities** shown are based on 100°F condensing
- **Brass screws** on inlet and
- **All capacities** shown are based on 100°F condensing
- **Minimum tonnage** is 33% of rated capacity
- **Working Pressure:** 450 PSI

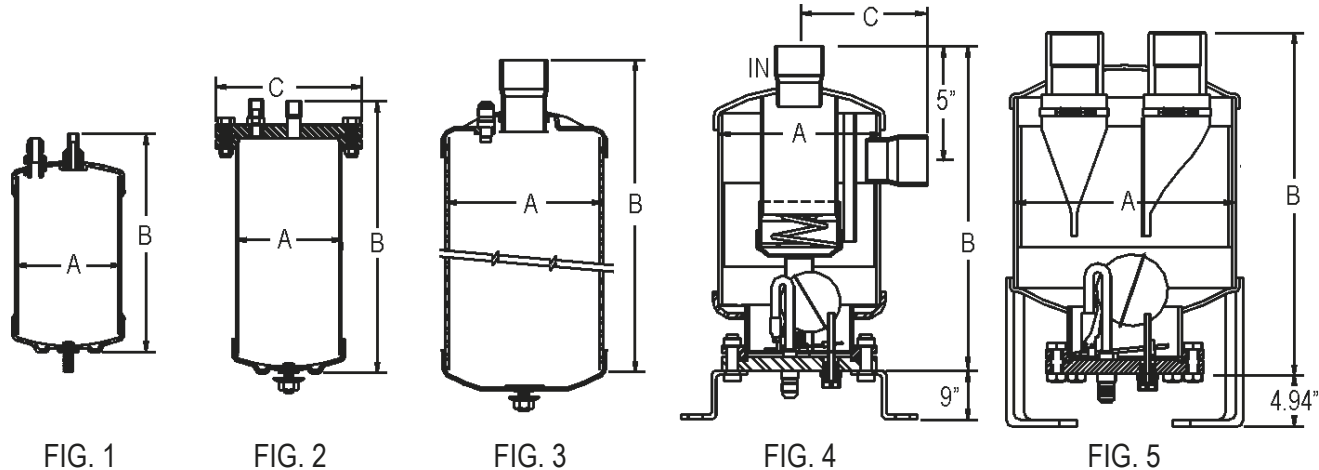

Catalog Number	Size Conn. O.D.S.	Fig #	Dimensions in Inches			Capacity in Tons of Ref. at Evap. Temp. (Nominal)						Max. Discharge CFM	Pre-Charge Amount
			Dia. A	B	C	R-134a		R-22		R-404a/R-507			
						-40°F	+40°F	-40°F	+40°F	-40°F	+40°F		
S-5580	1/4"	1	4	8.25	—	0.5	0.8	0.8	1.0	0.8	1.0	0.75	12
S-5581	3/8"	1	4	8.25	—	0.8	1.0	1.0	1.5	1.0	1.5	1.0	12
S-5582	1/2"	1	4	10.25	—	1.0	1.5	1.5	2.0	1.5	2.0	1.5	12
S-5585	5/8"	1	4	14.25	—	3.0	4.0	4.5	5.5	4.0	5.5	4.0	12
S-5587	7/8"	1	4	17.75	—	4.5	5.5	7.0	8.0	6.5	8.5	6.5	12
S-5588	1 1/8"	1	4	21	—	6.0	7.5	9.0	10.5	8.5	11.0	8.0	12
S-5590	1 3/8"	1	4	21.25	—	8.0	9.5	11.5	13.5	10.5	14.0	10.0	12
S-5882	1/2"	2	4	10.25	5.50	1.0	1.5	1.5	2.0	1.5	2.0	1.5	12
S-5885	5/8"	2	4	14.25	5.50	3.0	4.0	4.5	5.5	4.0	5.5	4.0	12
S-5887	7/8"	2	4	17.75	5.50	4.5	5.5	7.0	8.0	6.5	8.5	6.0	12
S-5888	1 1/8"	2	4	21	5.50	6.0	7.5	9.0	10.5	8.5	11.0	8.0	12
S-5890	1 3/8"	2	4	12.25	5.50	8.0	9.5	11.5	13.5	10.5	14.0	10.0	12
S-5687	7/8"	3	6	11.12	—	6.0	7.0	9.0	10.0	8.0	10.0	7.5	30
S-5688	1 1/8"	3	6	15.38	—	8.0	10.0	11.0	12.0	9.0	13.0	9.0	30
S-5690	1 3/8"	3	6	15.63	—	9.0	12.0	13.0	14.0	12.0	15.0	11.0	30
S-5692	1 5/8"	3	6	18.63	—	11.0	13.0	16.0	18.0	15.0	19.0	14.0	30
S-5694	2 1/8"	3	6	19.12	—	18.0	21.0	25.0	30.0	24.0	31.0	22.5	30
S-5792	1 5/8"	4	6	20.25	4.25	11.0	13.0	16.0	18.0	15.0	19.0	14.0	20
S-5794	2 1/8"	4	6	20.31	4.50	18.0	21.0	25.0	30.0	24.0	31.0	22.5	20
S-1901	1 5/8"	5	8	21	—	14.0	17.0	20.0	24.0	19.0	25.0	18.0	20
S-1902	2 1/8"	5	8	21	—	21.0	25.0	30.0	35.0	28.0	37.0	27.0	20
S-1903	2 5/8"	5	10	21.50	—	37.0	46.0	50.0	65.0	48.0	68.0	49.0	20
S-1904	3 1/8"	5	12	25.75	—	52.0	64.0	75.0	90.0	72.0	94.0	68.0	20

S-5500, S-5800, S-5600, S-5700: Connections are nickel plated steel. S-1900: Connections are copper plated steel. Oil flow rate @ 175 PSI differential: 0.80 gal/min.



# ALL-WELDED COALESCING

## Oil Separators



### Features:

- Constructed in accordance with ASME Section VIII
  - Assembly is all welded steel
  - Designed specifically for all reciprocating refrigeration compressors: Halocarbons, Ammonia and Hydrocarbons
  - Provides 10 times the oil removal rate of conventional oil separators
  - 5 models to choose from covering entire range of single stage and booster compressors
  - Oil float valve assembly with shut off valve available as optional accessory (SN-9142) See page 10.
  - Max. Allowable Working Pressure: 400 PSI
- Note: can be mounted either horizontally or vertically

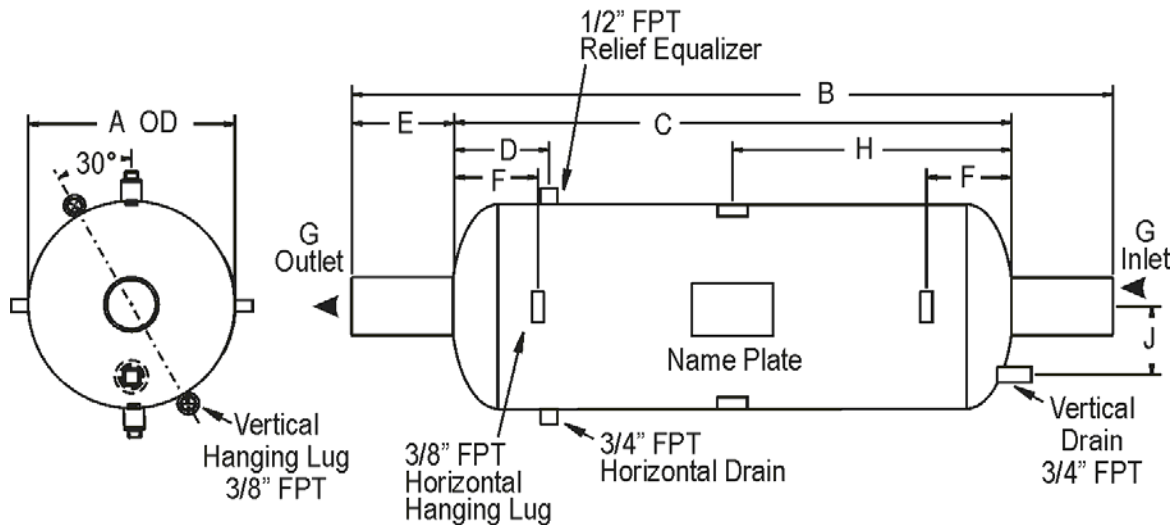

### D.C.F.M. Rating (Discharge Volumetric Flow)

Refrigerant	COS-030	COS-070	COS-140	COS-205	COS-250
Group 1 R-717 (Ammonia), Natural Gas	30	70	140	205	250
Group 2 R-290 (Propane), R744 (Carbon Dioxide)	25	65	135	200	225
Group 3 R-22, R-23, R-407C, R-410A, R508B	20	50	105	150	180
Group 4 R-134A, R-404A, R-507A, R-417A, R422D, R434A	19	45	95	140	160

\* For other Halocarbon Refrigerants Contact our Sales Office

Catalog Number	Dimensions in Inches								Conn. Size & Type G	Approx. Ship Wt. In Lbs.
	A	B	C	D	E	F	H	J		
COS-030 (F)	8.63	33	24	5	6.5	4	12	3	2" BW (2 1/8 ODS)	78
COS-070 (F)	12.75	43	34	7	6.5	5	17	4	2 1/2" BW (2 5/8 ODS)	238
COS-140 (F)	16	51	42	8	6.5	7.13	21	5	3" BW (3 1/8 ODS)	333
COS-205	18	61	52	8	6	7.63	26	5	4" BW	462
COS-250	20	65	53	9	6	8.25	26.5	6	5" BW	536

- Add suffix "F" to Catalog Number (Halocarbon):  
e.g. COS-030 has a 2 1/8 Butt Weld Connection; COS-030F has a 2 1/8 ODS Connection which can be cut back to 2" BW.





# COALESCING OIL SEPARATORS

For Replaceable Cartridges



### Features:

- Constructed in accordance with ASME Section VIII
- Assembly allows for easy replacement of the coalescing cartridge
- Designed specifically for all reciprocating refrigeration compressors: Halocarbons, Ammonia and Hydrocarbons
- Provides 10 times the oil removal rate of conventional oil separators
- **Five models** to choose from covering entire range of single stage and booster compressors
- **Removable and replaceable cartridges.**
- **Oil float valve assembly** (SN-9142 See page 10) with shut off valve available as optional accessory
- **Max. Allowable Working Pressure: 400 PSI**

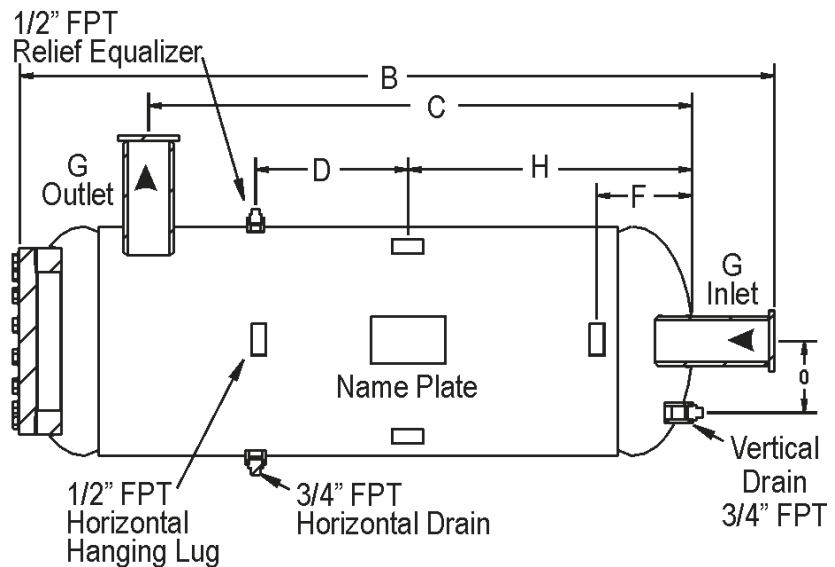
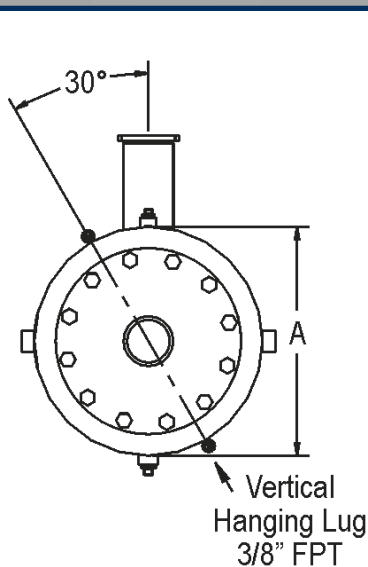

Refrigerant	D.C.F.M. Rating				
	COSM-030	COSM-070	COSM-140	COSM-205	COSM-250
R-717	30	70	140	205	250
R-22, R-502*	22	50	105	150	185

\* For other Halocarbon Refrigerants Contact our Sales Office

Catalog Number	Dimensions in Inches							Connection G	Approx. Ship Wt. in Lbs.
	A	B	C	D	E	F	H		
COSM-030 (F)	8 5/8	27 1/2	22 1/2	7	6 1/2	4	12	2 1/8 ODS (2) •	138
COSM-070 (F)	12 3/4	37 1/4	31	10	6 1/2	5	17	2 5/8 ODS (2 1/2) •	379
COSM-140 (F)	16	46	38 1/2	13	6 1/2	7 1/8	21	3 1/8 ODS (3) •	566
COSM-205 (F)	18	58 1/2	49 1/2	18	6	7 5/8	26	4 Weld Stud	773
COSM-250 (F)	20	60 3/4	50 1/2	17 1/2	6	8 1/4	26 1/2	5 Weld Stud	896

- Add suffix "F" to Catalog Number (Halocarbon):  
e.g. COS-030 has a 2 1/8 Butt Weld Connection; COS-030F has a 2 1/8 ODS Connection which can be cut back to 2" BW.



**Industrial & Commercial Refrigeration Products** 800.96.HENRY



### Features:

- ODS or butt weld connections available
- **Stainless Steel 303** screen mesh filter media.
- **Oil Float Valve Assembly** with shut-off valve (SN-9142 available as optional accessory) suitable for ammonia use.
- **All Welded Design**
- **Oil Separators** are all rated at 400 P.S.I. working pressure
- Constructed in accordance with ASME Section VIII
- **Max. Allowable Working Pressure: 400 PSI**

Shutoff Valve: 7771

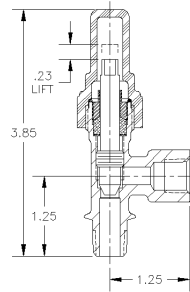

Oil Float Valve: SN-9142

Replacement Float: SN-9140-30

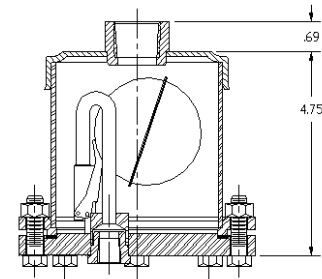

Catalog Number	Description	Inlet	Outlet
SN-9142	Oil Float Valve	3/4" NPT Int.	1/4" NPT Int.
7771	Shutoff Valve	1/4" NPT Ext.	1/4" NPT Int.

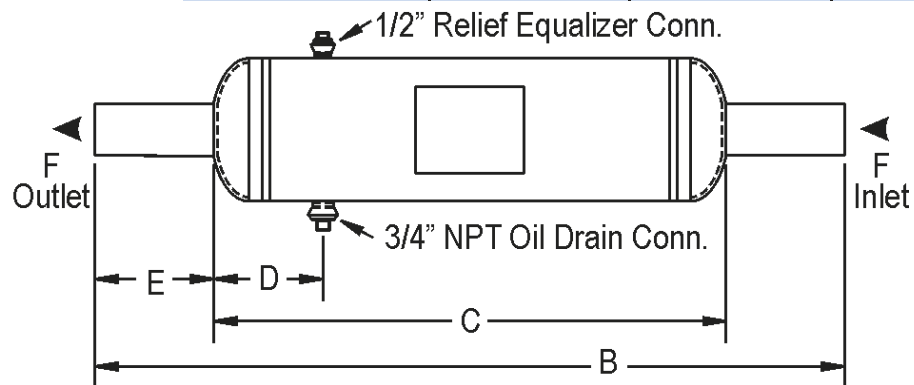
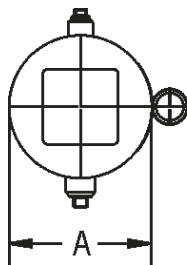

Catalog Number	Rating in CFM*		Shipping Weight lbs.	Dimensions in Inches					F	
	Max.	Min.		A	B	C	D	E	Weld Stud	O.D.S. **
O-100 (F)	100	20	38	6-5/8	32	24	5-1/2	4	2	2-1/8
O-175 (F)	175	30	45	8-5/8	32	24	5-1/2	4	2-1/2	2-5/8
O-250 (F)	250	50	76	10-3/4	32	24	5-1/2	4	2-1/2	2-5/8
O-350 (F)	350	75	120	12-3/4	40	32	9-1/2	4	3	3-1/8
O-650	650	100	172	14	40	32	9-1/2	4	4	—
O-900	900	150	251	16	52	44	15-1/2	4	4	—
O-1500	1500	250	367	20	56	44	15-1/2	6	6	—

\* Compressor Displacement in cubic feet per minute. \*\* Weld stub connections are standard.