

Williamson

OSB

Series 2

Factory-Packaged
0.95 to 1.75 GPH #2 Fuel Oil

Oil-Fired Steam Boiler



- **Factory Tested**
- **Probe Type Low Water Cutoff**
- **Easy service**
 - Swing-away burner door
 - Top access cleanout cover
 - Plug-in wiring harness
- **High efficiency oil burner**
 - Solenoid valve
 - PSC motor
 - Solid state ignitor
- **Rear flue outlet**
 - Top flue available with optional kit
- **Cast iron sections**
- **Insulated heavy-gauge steel jacket**
- **Tankless heater option**



Williamson

RATINGS

Boiler Model	Burner Input		AHRI Ratings		Seasonal Efficiency	Flue Outlet Diameter	Minimum Chimney Size (x 15' High)			Draft Loss Through Boiler	Approx. Shipping Weight
	GPH (1)	MBH (2)	MBH (3)	Sq. Ft. (3)			% AFUE	Round	Rectangle		
OSB-3	0.95	114	86	358	84.0	7"	8" x 8"	6"	0.020	600	
OSB-4	1.20	144	108	450	84.0	7"	8" x 8"	6"	0.010	705	
OSB-5	1.45	174	131	546	83.9	7"	8" x 8"	7"	0.015	820	
OSB-6	1.75	210	158	658	83.7	7"	8" x 8"	7"	0.015	920	

(1) MBH refers to thousands of Btu per hour. Based on 140,000 Btu/gal.

(2) Based on standard test procedures prescribed by the United States Department of Energy, with combustion conditions of 13.5% CO₂ and 0.02" W.C. draft.

(3) Net AHRI ratings are based on net installed radiation of sufficient quantity for the requirements of the building and nothing need be added for normal piping and pickup. Ratings are based on a piping and pickup allowance of 1.333. Additional allowance should be made for unusual piping and pickup loads.

DIMENSIONS

ALL DIMENSIONS IN INCHES

Boiler Model	Optional tankless heater ⑨	I=W=H Intermittent draw rating (40°F to 140°F)
OSB-3	35-S-29	3.25 GPM
OSB-4		3.50 GPM
OSB-5		3.75 GPM
OSB-6		4.00 GPM

Tankless heater tappings are 3/4" NPT, with 3/4" NPT tapping for tankless temperature control.

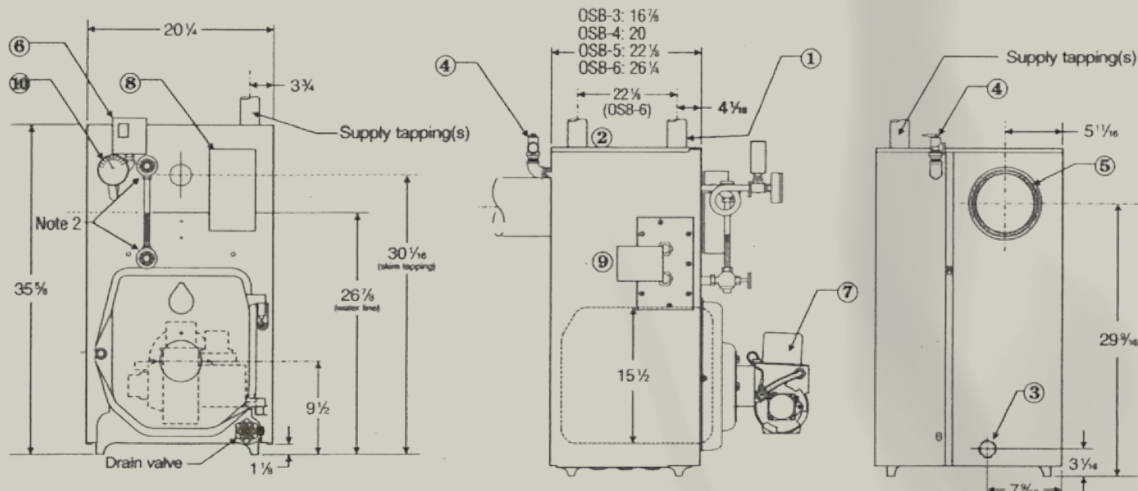

① Supply piping (Note 1)

② Supply piping two, OSB-6 only (Note 1)

③ Return piping (Note 1)

④ Relief valve, 3/4" NPT

⑤ Vent connection—7" diameter

⑥ Pressure limit control

⑦ Oil burner (shipped in separate carton)

⑧ Probe-type low water cutoff

⑨ tankless coil & temp. control (when used)

⑩ Pressure gauge

Note 1: Boiler supply tappings are 2 1/2" NPT. Return tapping is 2" NPT on all boiler sizes. Install one 2 1/2" supply riser for models OSB-3, OSB-4 and OSB-5; two 2 1/2" supply risers for size OSB-6.

Note 2: If field-installing a float low water cutoff, it must be installed in the gauge glass tappings. No other tappings are usable for float low water cutoffs.

EQUIPMENT

- Factory tested
- Factory-assembled cast iron section assembly, including aluminized steel flue collector, swing-away burner mounting door, with refractory blanket and recessed target wall in combustion chamber.
- High efficiency flame-retention oil burner (Beckett AFG or NX, Carlin, or Riello)
- High limit pressure control

- 15 PSIG ASME relief valve
- Drain Valve
- Barometric damper
- Siphon
- Gauge glass and guards
- Pressure gauge
- Probe low water cutoff

OPTIONAL

- Top flue vent kit
- Tankless heater, shipped in separate carton



In the interest of continual improvement in product and performance, Williamson reserves the right to change specifications without notice.



Williamson®

8201 West Calumet Road • Milwaukee, WI 53223

www.williamson-thermoflo.com

Form No. W-007 (1116)