

Webstone

VALVE INNOVATION

AIR SEPARATOR

w/ Removable Vent Head & Coalescing Medium

KNOCKING PIPES
ARE **NOT NORMAL**

The Webstone Air Separator uses a unique coalescing medium to capture both micro bubbles and static air from within a hydronic heating system.

- Reduces noise
- Improves system efficiency and operation
- Reduces wear on system components
- Requires no regular maintenance
- Fewer call backs

**IDEAL FOR
USE WITH**

**PRO-PAL
SERIES**

**EXPANSION TANK
PRO SERVICE VALVE**

ITEM#	SIZE	CTN/CASE
41672	1/2"	1/30

AVAILABLE IN



HOW IT WORKS

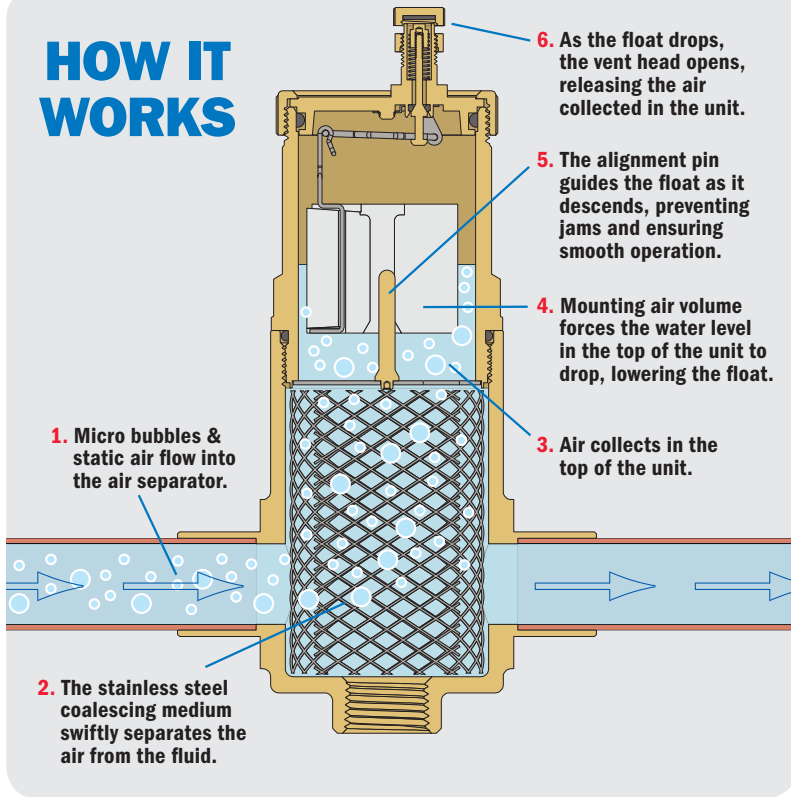

DESIGN ADVANTAGES

- Stainless steel coalescing medium is a more durable alternative
- Pin guided float ensures smooth operation
- Vent head & coalescing medium can be removed for cleaning
- Flow may be directed into either side of the unit
- Replacement Vent Assemblies are available
- Guaranteed for life

FORGED BRASS AIR SEPARATORS

w/ Removable Vent Head & Coalescing Medium

150 PSI • ISO 9001

	ITEM #	SIZE	CTN/CASE	A	B	C	D	Max GPM
IPS	74003	3/4"	1/10	6 1/4	3 5/8	3/4	1/2	6
	74004	1"	1/10	6 1/4	3 3/4	1	1/2	10
	74005	1 1/4"	1/10	6 1/4	3 7/8	1 1/4	1/2	15
	74006	1 1/2"	1/10	9 1/8	5	1 1/2	1/2	30
	74007	2"	1/10	9 1/8	5 1/8	2	1/2	40
C×C	75003	3/4"	1/10	6 1/4	4	3/4	1/2	6
	75004	1"	1/10	6 1/4	4 1/2	1	1/2	10
	75005	1 1/4"	1/10	6 1/4	4 1/2	1 1/4	1/2	15
	75006	1 1/2"	1/10	9 1/8	5 5/8	1 1/2	1/2	30
	75007	2"	1/10	9 1/8	6 1/8	2	1/2	40
PRESS	78003	3/4"	1/10	6 1/4	7	3/4	1/2	6
	78004	1"	1/10	6 1/4	7 3/8	1	1/2	10
	78005	1 1/4"	1/10	6 1/4	7 11/16	1 1/4	1/2	15
	78006	1 1/2"	1/10	9 1/8	9 1/8	1 1/2	1/2	30
	78007	2"	1/10	9 1/8	9 7/8	2	1/2	40



REPLACEMENT VENT ASSEMBLY

ITEM #	FITS	CTN/CASE
74000	3/4"-2" Air Separators	1/50

NO DESCRIPTION MATERIAL

1	LOWER BODY	BRASS
2	UPPER BODY	BRASS
3	BODY CAP	BRASS
4	BODY CAP RING	BRASS
5	VENT CAP	BRASS
6	VENT CAP WASHER	BRASS
7	VENT PIN ASSEMBLY	BRASS
8	VENT SPRING	STAINLESS STEEL
9	VENT O-RING	EPDM
10	VENT/FLOAT ARM ASSEMBLY	STAINLESS STEEL
11	BODY CAP O-RING	EPDM
12	FLOAT	PLASTIC
13	FLOAT ALIGNMENT PIN	BRASS
14	BODY O-RING	EPDM
15	BAFFLE	STAINLESS STEEL
16	MESH	STAINLESS STEEL

IPS & C×C

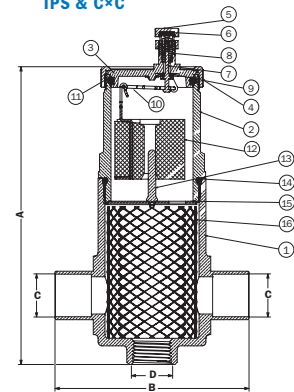

NO	DESCRIPTION	MATERIAL	NO	DESCRIPTION	MATERIAL
1	UPPER BODY	BRASS	14	BODY CAP O-RING	EPDM
2	BAFFLE	STAINLESS STEEL	15	BODY CAP RING	BRASS
3	FLOAT ALIGNMENT PIN	BRASS	16	VENT CAP WASHER	EPDM
4	BODY CAP	BRASS	17	VENT CAP	BRASS
5	VENT O-RING	EPDM	18	BODY O-RING	EPDM
6	VENT SPRING	STAINLESS STEEL	19	MESH	STAINLESS STEEL
7	VENT PIN ASSEMBLY	BRASS	20	LOWER BODY	BRASS
8	VENT LOCATING NUT	BRASS	21	PRESS FITTING BODY	BRASS
9	VENT BRACKET	STAINLESS STEEL	22	PRESS FITTING O-RING	EPDM
10	SNAP RING	STAINLESS STEEL			
11	VENT/FLOAT ARM ASSEMBLY	STAINLESS STEEL			
12	FIXED LINK	STAINLESS STEEL			
13	FLOAT ALIGNMENT PIN	PLASTIC			

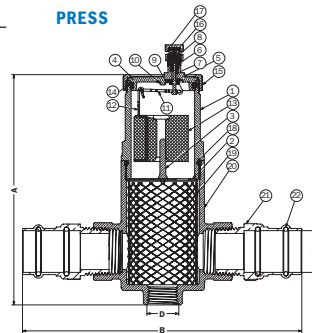

Webstone

VALVE INNOVATION

ONE APPIAN WAY WORCESTER, MA 01610
 P.O. BOX 59 WORCESTER, MA 01613
 P: (800) 225-9529 · F: (800) 336-5133
www.webstonevalves.com