



THERMOSTATIC MIXING VALVE

INSTALLATION & SERVICING INSTRUCTIONS

The Webstone TMV is designed for use in heating as well as domestic water systems and provides outlet temperatures ranging between 95°–131° F. The valve may be positioned in any orientation; designated lengths of straight piping before and after the unit are not required. The Webstone Thermostatic Mixing Valve is a SAFETY VALVE. Inspect the TMV at least once per year to verify it is operating correctly. It may be necessary to check the valve more frequently in installations with poor or unknown water quality. Use of a filter or strainer is required for installations with poor or unknown water quality.

IMPORTANT: Follow all federal/national, state and local codes when installing, testing or performing work on systems. All parts are covered by a lifetime warranty against manufacturing defects provided they are installed by a licensed plumber and operated under normal working conditions. Disassembling will void this warranty. If you have any questions or comments, please contact us at (800) 225-9529 or visit us on the web - www.webstonevalves.com.

WARNING: This valve was not designed for installations exposed to subfreezing conditions; use suitable insulation if this possibility exists in your installation. Subjecting the Webstone TMV to heat during installation may damage the valve internals. The Webstone TMV is designed for use in water systems only. DO NOT use the TMV in steam systems. The use of excessive thread sealant may cause the Webstone TMV to fail.

INSTALLATION

1. Prepare the system for the TMV installation:
 - a. **Flush the system thoroughly before fitting the Webstone TMV.** It is critical to flush all debris from the pipework before installing the Webstone TMV. This step eliminates the most common cause of system difficulties.
 - b. Check the specifications of your Webstone TMV against site parameters, such as temperature and pressure. Rectify any conditions outside the valves specifications before installation.
2. Attach a union assembly to each end of the valve body.
Series 7520 & 7420 ONLY - Check valve fittings may only be installed on the hot and cold inlet.
3. Ensure that each union nut is aligned accurately to the valve and that washers are properly in place.
4. Connect the hot water supply line to the inlet marked HOT.
5. Connect the cold water supply line to the inlet marked COLD.
6. Connect mixed water line to outlet marked MIX, also indicated with a flow arrow.
7. Fully tighten the union assemblies at each connection.
8. Set the output to the desired temperature* by aligning the numbers on the handle with the mark on the valve body in accordance with the table below:

Handle Marking	1	2	3	4
Output Temperature	95°F (35°C)	109°F (43°C)	119°F (48°C)	131°F (55°C)

* Output temperature may vary slightly due to seasonal changes in cold water supply temperatures. Numbers on handle are calibrated at the time of manufacture and should be used for initial commissioning of valve only.

9. Verify that the correct mixed water temperature is being achieved:
 - a. Open the nearest water outlet supplied by the TMV to a flow of 2 to 3 gpm. It is important to test the temperature at the nearest outlet to ensure water delivered to any outlet is not greater than the desired maximum.
 - b. Allow the water to reach a stable temperature and measure.
10. Turn the handle clockwise to decrease, or counter-clockwise to increase the outlet temperature as needed.

SETTING TEMPERATURE LOCK (OPTIONAL)

If desired, the temperature range can be limited on the Webstone TMV by locking the handle in place:

1. Set and verify the mixed water temperature, following the steps above.
2. Remove screw and handle.
3. Align Internal Pin on handle with slot on Temperature Limit Stop.
4. Replace handle and secure screw.

NOTE: Field calibration may be needed if handle has been removed or locked.

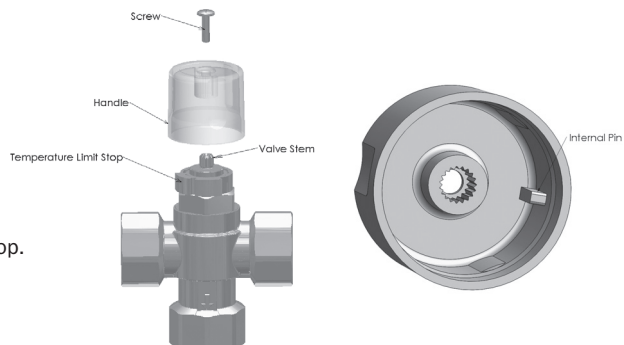

SERVICING AND INSPECTION

- The Webstone Thermostatic Mixing Valve is a SAFETY VALVE. Inspect the TMV at least once per year to verify it is operating correctly. It may be necessary to check the valve more frequently in installations with poor or unknown water quality. Outlet temperature may vary due to seasonal changes in cold water supply temperatures.
- When testing, verify the temperature at the same water outlet measured during initial setup. Allow water temperature to stabilize before measuring. If the temperature differs more than 3°F from initial setup, refer to the troubleshooting table below.

Problem	Solution
Unable or difficult to set correct mixed water temperature	<ul style="list-style-type: none"> • Ensure inlet temperatures meet TMV specifications • Ensure that hot and cold supply lines have not been reversed • Ensure strainers are not blocked
Mixed water temperature is not stable or changes over time	<ul style="list-style-type: none"> • Ensure strainers are not blocked • Ensure supply pressures are stable. Install pressure regulating valves to correct
Full hot or full cold water flowing from MIX outlet	<ul style="list-style-type: none"> • Verify valve temperature setting • Ensure that hot and cold supply lines have not been reversed • Ensure that check valves are not clogged or damaged • Ensure inlet temperatures meet TMV specifications
No flow from MIX outlet	<ul style="list-style-type: none"> • Ensure adequate hot or cold water supply • Ensure inlets are not blocked
Reduced or inconsistent flow rate	<ul style="list-style-type: none"> • Ensure inlets are not blocked • Ensure supply pressures are stable. Install pressure regulating valves to correct
Mixed water temperature remains same when handle is moved	<ul style="list-style-type: none"> • Ensure that hot and cold supply lines have not been reversed
Hot water flows into the cold water system, or cold water flows into hot water system	<ul style="list-style-type: none"> • Ensure that check valves are not clogged or damaged
TMV is noisy	<ul style="list-style-type: none"> • Ensure water supply pressures are within TMV specifications. Install pressure regulating valves to correct • Ensure TMV is correct size for required flow

SPECIFICATIONS

Outlet temperature range	95–131°F (35–55°C)
Maximum hot supply	185°F max (85°C)
Maximum cold supply	43–80°F (6°C)
Temperature stability (nominal)	± 3°F ¹ (± 1°C)
Temperature differential (between hot supply and outlet temperature)	20°F ² (11°C)
Working pressure	30–150 psi (2–10 bar)
Permitted inlet supply pressure variation	2:1 ³
Flow rate C_v	1/2" – 1.4 3/4" – 2.0 1" – 3.5
Flow rate, minimum	1.0 gpm (4 L/min)

1. As tested in accordance with ASSE1017.

2. This is the minimum difference required between the valve outlet temperature and the hot supply temperature to enable the valve to function correctly and ensure shut-off of outlet flow in the event of cold supply failure.

3. Maximum permitted variation in either supply pressure in order to control the outlet temperature to within ±3°F. Excessive changes in supply pressures may cause changes in outlet temperature.