

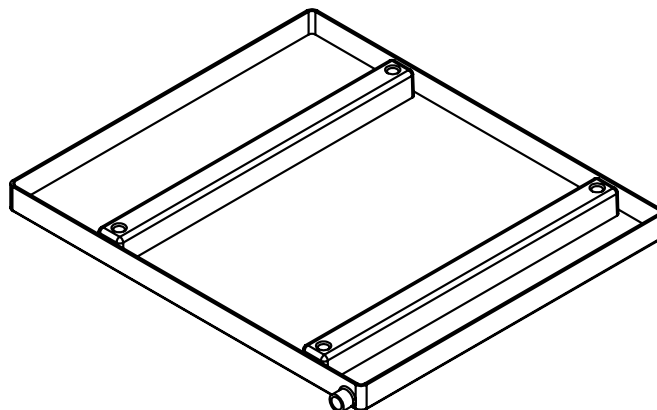

BASE PAK SECONDARY DRAIN PANS FOR HORIZONTAL FAN COIL UNITS



SpacePak has designed a series of secondary drain pans specifically sized for use with all horizontal fan coil units. Exclusive built-in supports raise the unit off the bottom of the drain pan. Installed with threaded rod, the unique pan construction fully supports the fan coil unit. For use with ESP-E/D or WCSP-D series coil units.

STANDARD FEATURES

- Durable polyethylene will not rust
- Resistant to mold growth
- UL recognized material
- Integral multi-function support channels
- Supports unit when suspended with threaded rod
- Fits through hole cut-out used for return air box
- Threaded 3/4" drain connection
- Meets International Mechanical Code 307.2.3

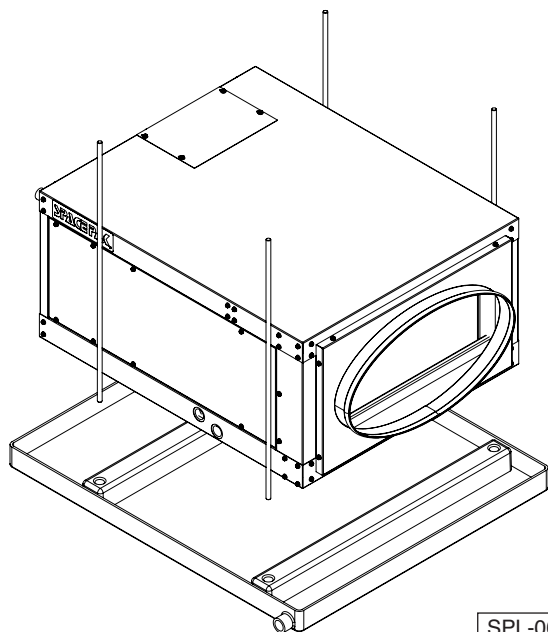

SPL-0086

DIMENSIONAL DATA (inches)

Unit Size	2430	3642	4860
Model #	AC-BASE-2	AC-BASE-3	AC-BASE-5
Height	2-3/16	2-3/16	2-3/16
Width	29	38	48
Length	32-1/2	32-1/2	32-1/2
Wt./pc (Lbs.)	7	9	11