

Raychem FREEZGARD SELF-REGULATING CRANKCASE HEATER

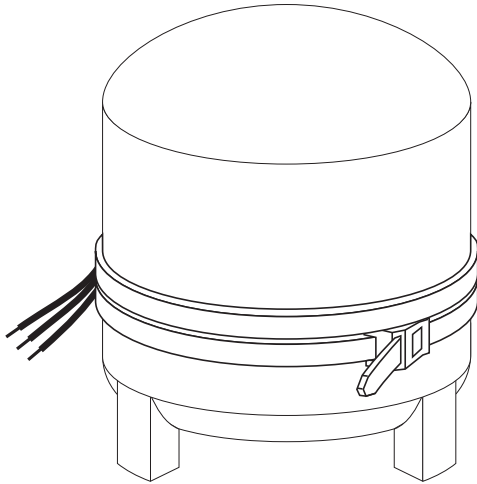

PRODUCT OVERVIEW

When compressors operate in cold areas, refrigerant can migrate into the crankcase oil whenever the compressor is not running. On start-up, this can cause excessive motor wear and a loss of refrigeration efficiency.

Raychem FreezGard self-regulating crankcase heaters provide reliable peak heating during critical cold periods and, unlike conventional constant-wattage heaters, reduce their heating once the compressor starts up or the air temperature rises. Also, self-regulating heaters can be safely overlapped and closely spaced without burning out; so one size fits all hermetic compressors up to 5 HP that are 40 inches or less in circumference.

Models for both 120 V and 208 to 277 V are available. Each comes with a flexible lock-strap and prestripped 28-inch cold leads for easy connection and hard-wiring. Use only with refrigeration compressors in nonhazardous areas.

Benefits include:

- Prolongs motor life
- Installs easily
- Works effectively and reliably
- Increases compressor efficiency

SPECIFICATIONS

Service voltage [CCH-1C]	120 V
Service voltage [CCH-2C]	208–277 V
Power at 50°F (10°C)	32 watts (minimum)
Power at 0°F (–18°C)	60 watts (minimum)
Cold lead wire gauge	18 AWG
Cable width (nominal)	0.615 in (1.56 cm)
Cable thickness (nominal)	0.245 in (.62 cm)
Cable length	48 in (122 cm)
Cold lead length	28 in (71 cm)
Intermittent max. exposure temperature	185°F (85°C)
Insulation jacket type	Modified polyolefin
Girth (wraparound) dimension	40 in (102 cm) or less in circumference

FREEZGARD

APPROVALS



BUS WIRES

16 AWG nickel-plated copper

BRAID / OUTER JACKET

Tinned-copper braid with modified polyolefin outer jacket

GROUND-FAULT PROTECTION

To minimize the danger of fire from sustained electrical arcing if the heating cable is damaged or improperly installed, and to comply with the requirements of Pentair Thermal Management, agency certifications, and national electrical codes, ground-fault equipment protection must be used on each heating cable branch circuit. Arcing may not be stopped by conventional circuit protection.



WWW.PENTAIRTHERMAL.COM

NORTH AMERICA

Tel: +1.800.545.6258
Fax: +1.800.527.5703
Tel: +1.650.216.1526
Fax: +1.650.474.7711
thermal.info@pentair.com

EUROPE, MIDDLE EAST, AFRICA

Tel: +32.16.213.511
Fax: +32.16.213.603
thermal.info@pentair.com

ASIA PACIFIC

Tel: +86.21.2412.1688
Fax: +86.21.5426.2917
cn.thermal.info@pentair.com

LATIN AMERICA

Tel: +1.713.868.4800
Fax: +1.713.868.2333
thermal.info@pentair.com

Pentair and FreezGard are owned by Pentair or its global affiliates. All other trademarks are the property of their respective owners. Pentair reserves the right to change specifications without prior notice.

© 1997–2014 Pentair.