

SERIES 35-65 & 35-66



24 VAC Microprocessor Based HSI Control with 120/240 Field Selectable Line Voltage Capability

35-65,-66.02

FEATURES

- Safe start and full-time flame sensing
- 120/240 field selectable line voltage for use with 120 VAC ignitor option
- 24/120/240 VAC hot surface ignitor models available
- Blower control and airflow switch monitoring option
- Diagnostic LED
- Multiple trials for ignition
- Automatic reset option
- Local or remote flame sensing
- Flame current test pins
- Dual speed blower option for LoNox applications
- Fail-safe gas valve control (35-66 only)
- CE models available



APPLICATIONS

- Pool and spa heaters
- Gas furnaces
- Water heaters
- Any 24 VAC gas burner application under 400K BTU

DESCRIPTION

The Series 35-65 and 35-66 controls are designed to perform many gas-fired 24 VAC appliance functions in a single control, resulting in lower system cost. This series monitors the demand for heat, controls the combustion blower, monitors proper airflow, ignites and maintains the flame during heating, and provides diagnostic support. The on-board diagnostics with LED output provide assistance with troubleshooting and ensures safe and efficient burner operation.

The microprocessor circuit design provides precise, repeatable timing sequences for ignition and purge times (pre-, inter-, and post-) as well as multiple tries for ignition. The optional 120/240 VAC field selectable line voltage capability provides additional field service efficiency and lower inventory costs.

Agency Certifications



Design certified by CSA International to CAN C22.2 #199-M89 and ANSI Z21.20 for Automatic Ignition Systems, including UL1998 software review. FM approval and CE pending on selected models.

SPECIFICATIONS

INPUT POWER	
Voltage	Control: 18 to 30 VAC 50/60 Hz (Class 2 Transformer) Line: 24, 120 or 240 VAC (L1 & L2 only)
Current	300 mA max @ 24 VAC with blower and gas valve relay energized (Control only)
OUTPUT (CONTACT RATINGS)	
Gas Valve	2.0A max @ 24 VAC
Combustion Blower (Model 35-66 only)	3.0 FLA max @ 120 VAC (1/4 hp) 1.5 FLA max @ 240 VAC (1/4 hp)
Hot Surface Element	5.0A max @ 120/240 VAC
OPERATING TEMPERATURE	-40°F to +176°F (-40°C to +80°C)
FLAME SENSITIVITY	0.7 microamps minimum
TYPES OF GAS	Natural, LP, or manufactured
IGNITOR	24 VAC, 120 VAC, or 240 VAC mini-ignitors and silicon carbide ignitors depending on model
ENCLOSURE	Gray (Noryl N-190)
MOISTURE RESISTANCE	Conformal coated to operate non-condensing to 95% R.H. Care must be taken to protect module from direct exposure to water
SIZE WITH ENCLOSURE	See Figures on Page 7
WEIGHT	8 oz including cover

SEQUENCE OF OPERATION / FLAME RECOVERY/ SAFETY LOCKOUT

POWER-UP / STANDBY

35-66 with Full-Time Power (R Models only):

Upon applying power (24 volts) to the R terminal, the control will reset, perform a self-check routine, flash the diagnostic LED for a second and enter the thermostat scan state.

CALL FOR HEAT

35-65 & 35-66 without Full-Time Power (R Terminal):

When a call for heat is received from the thermostat supplying 24 volts to the W terminal, the control will perform a self-check routine, flash the diagnostic LED for a second and begin the safety timing sequence. After an optional "pre-purge" period, the hot surface ignitor is energized for a heat-up period, followed by the gas valve for the "trial for ignition" (TFI) period.

Call for Heat - 35-66 Models:

In addition to the self-check routine described above, when a call for heat is received from the thermostat supplying 24 volts to the W terminal, the control will check the pressure switch for normally open contacts. The combustion blower is then energized and, once the pressure switch contacts close, an optional "pre-purge" period begins. After pre-purge, the hot surface ignitor is energized for a heat-up period, followed by the gas valve for the "trial for ignition" (TFI) period.

Ignition - 35-65 Models:

When the flame is detected during the TFI period, the ignitor is de-activated and the gas valve remain energized. The thermostat and main burner flame are constantly monitored to assure that the system operates properly. When the thermostat is satisfied and the demand for heat ends, the gas valve is immediately de-energized.

Ignition - 35-66 Models:

When the flame is detected during the TFI period, the ignitor is de-activated and the gas valve and combustion blower remains on. The thermostat, pressure switch and main burner flame are constantly monitored to assure that the system operates properly. When the thermostat is satisfied and the demand for heat ends, the gas valve is immediately de-energized, the control senses the loss of flame signal and initiates an optional "post-purge" period before de-energizing the combustion blower.

FAILURE TO LIGHT - LOCKOUT

Single Try Models:

Should the main burner fail to light or the flame is not detected during the TFI period, the control will lockout. The gas valve will be turned off immediately. For 35-66 models, the combustion blower will be turned off following an optional "post-purge" period. With the 1 hour reset option, if the thermostat is still calling for heat, the control will automatically reset and attempt a new TFI sequence after one hour.

FAILURE TO LIGHT - LOCKOUT (continued):

Multi-try Models:

Should the main burner fail to light or the flame is not detected during the first TFI period, the gas valve is de-energized and the control performs an optional "inter-purge" delay before attempting another TFI period. The control will attempt 2 additional TFI's periods before locking out. In lockout, the gas valve will be turned off immediately. For 35-66 models, the combustion blower will be turned off following an optional "post-purge" period. With the 1 hour reset option, if the thermostat is still calling for heat, the control will automatically reset and attempt a new TFI sequence after one hour.

Lockout Recovery:

Recovery from lockout requires a manual reset by either resetting the thermostat or by removing the 24 volts for a period of 5 seconds.

Loss of Flame - Re-ignition:

If the established flame signal is lost while the burner is operating, the control will respond within 0.8 seconds. The gas valve is de-energized immediately and a new TFI sequence begins. If the burner does not relight, the control will lockout as previously described in the "Failure to Light - Lockout" section. Multi-try models will make 2 more attempts to light the burner. If flame is re-established, normal operation resumes.

COMBUSTION AIR FLOW PROBLEMS

35-66 Models only:

1. Combustion airflow is continually monitored during the ignition sequence by the pressure switch (PSW terminal). If the pressure switch contacts remain closed for 30 seconds at the start of the ignition sequence without an output signal to the combustion blower, an airflow fault is signaled and the control will remain in this fault mode with the combustion blower off. If the pressure switch contacts later open while there is still a call for heat, the control begins the pre-purge period followed by a normal TFI sequence.

2. If the pressure switch contacts remain open for more than 30 seconds after the combustion blower output (F1 and F2 terminals) is energized, an airflow fault is signaled and the control will remain in this fault mode with the combustion blower on. If proper airflow is later detected from the pressure switch input (PSW terminal), the control begins the pre-purge period followed by a normal TFI sequence.

3. If the airflow signal is lost while the burner is firing, the control will immediately de-energize the gas valve and an airflow fault is signaled. The combustion blower will remain on for the post-purge period and the control continues to monitor the PSW input waiting for airflow to return. If proper airflow is detected during the post-purge period, a normal TFI sequence begins preceded by any pre-purge period. If not, the control will enter a lockout condition with the combustion blower off.

Flame Fault (Full Time Power Models Only):

During normal sequence if an erroneous flame signal occurs, due to the gas valve failing to close completely, the controller will energize the combustion blower. Should the gas valve later close completely and the flame signal be removed, the combustion blower will power off following an optional post-purge period.

FAULT CONDITIONS

LED INDICATION	FAULT MODE
Steady On	Internal Control Failure
1 Flash	Airflow Fault (35-66 models)
2 Flashes	Erroneous Flame Signal
3 Flashes	Lockout

MOUNTING AND WIRING

The 35-65 and 35-66 models are not position sensitive and can be mounted vertically or horizontally. The control may be mounted on any surface and fastened with #6 sheet metal screws. Secure the control in an area that will experience a minimum of vibration and remain below the maximum ambient temperature of 80°C (175°F).

All connections should be made with UL approved, 105°C (221°F) rated 18 gauge, stranded wire with .054" minimum insulation. Refer to wiring diagram on Pages 5 or 6 when connecting the control to other components in the system.

Terminal Designations

TERMINAL	DESCRIPTION	TERMINATION
R	24 VAC supply to processor (optional full time power)	¼ in. Quick Connect
W	Thermostat Input	¼ in. Quick Connect
L1	120/240VAC Input (Hot)	¼ in. Quick Connect (or 5-pin Mate-N-Loc)
L2	Neutral	¼ in. Quick Connect (or 5-pin Mate-N-Loc)
GND	System Ground	¼ in. Quick Connect
GV	Gas Valve	3/16 in. Quick Connect
FS	Remote Flame Sense	¼ in. Quick Connect
S1 - 120	120 VAC Ignitor	¼ in. Quick Connect
S2	Ignitor	(or 5-pin Mate-N-Loc)
S1 - 240	240 VAC Ignitor	¼ in. Quick Connect (or 5-pin Mate-N-Loc)
FC+ & FC-	Flame Current Test Pins	¼ in. Quick Connect
35-66 Models Only		
F1	Blower Output	¼ in. Quick Connect (or 2-pin Mate-N-Loc)
F2	Blower Output	¼ in. Quick Connect (or 2-pin Mate-N-Loc)
PSW	Pressure Switch Input	¼ in. Quick Connect



CAUTION:

Operation outside specifications could result in failure of the Fenwal product and other equipment with injury or death to people and damage to property. Service to this product should only be performed by a qualified technician.



CAUTION:

Label all wires prior to disconnection when servicing the control. Wiring errors can cause improper and dangerous operation.

TROUBLESHOOTING GUIDE

SYMPTOM	RECOMMENDED ACTIONS
1. Does not start	A. Miswired B. 24 VAC Transformer bad C. Fuse/Circuit breaker bad D. Bad control, check LED for steady on or flashing codes
2. Thermostat on - no ignition	A. Miswired B. Bad thermostat, no voltage at thermostat terminal W C. Failed ignitor
3. Valve on - no ignitor	A. Defective ignitor B. Miswired C. Bad control, check voltage at ignitor
4. Ignitor on - no valve	A. Valve coil open B. Open valve wire C. Bad control, check voltage at gas valve terminal
5. Flame okay during TFI - no flame sense after TFI	A. Bad ignitor B. Bad S1 wire C. Poor ground at burner D. Poor flame, check flame current

Flame current is the current that passes through the flame from the sensor to ground. The minimum flame current necessary to keep the system from lockout is 1 microamp. To measure flame current, connect an analog DC microammeter to the FC terminals per diagram below. Meter should read 1 microamp or higher. If meter reads below "0" on scale, meter leads are reversed. Disconnect power and reconnect meter leads for proper polarity

FLAME SENSOR CURRENT CHECK

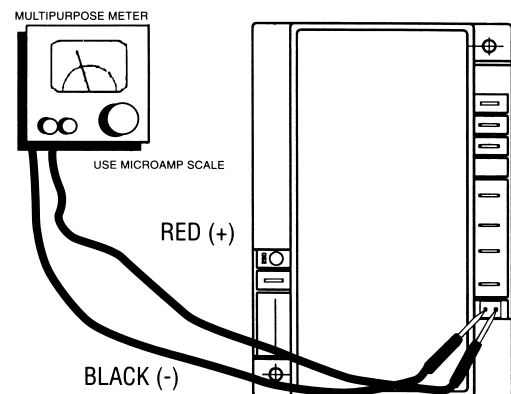

CONTROL WIRE HARNESS

Select the proper harness based on the 35-65 and 35-66 control's termination connection on back page. Once the terminal configuration is determined, complete the part number by replacing the last two digits ("XX") with the length in inches ("I" dimension). Standard wire lengths are 12, 18, 24, 30, 36 and 48 inches. Example 05-129845-018 = 18 inches. For other lengths, please contact Fenwal

Part Number: 05-128844-0XX

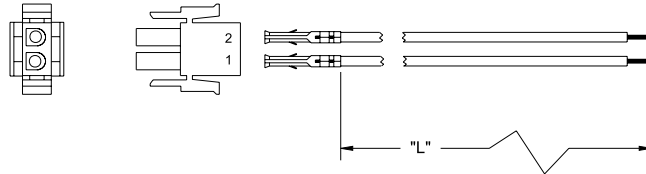

Part Number: 05-128981-XXX

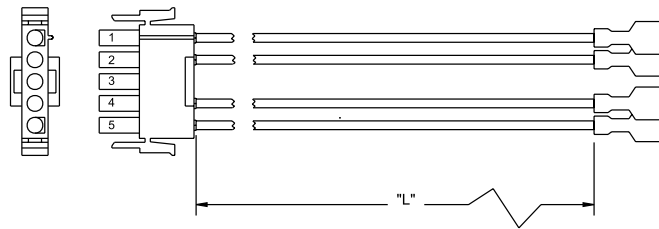

REMOTE FLAME SENSE RODS

Part Number: 22-100001-080

Custom configurations are available

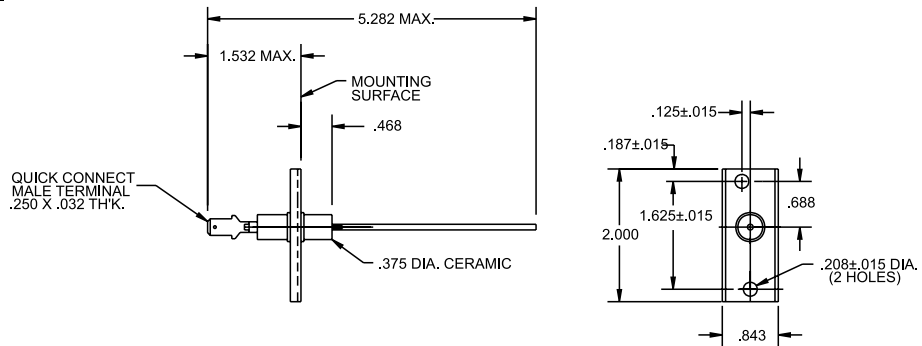

Part Number: 22-100001-110

Custom configurations are available

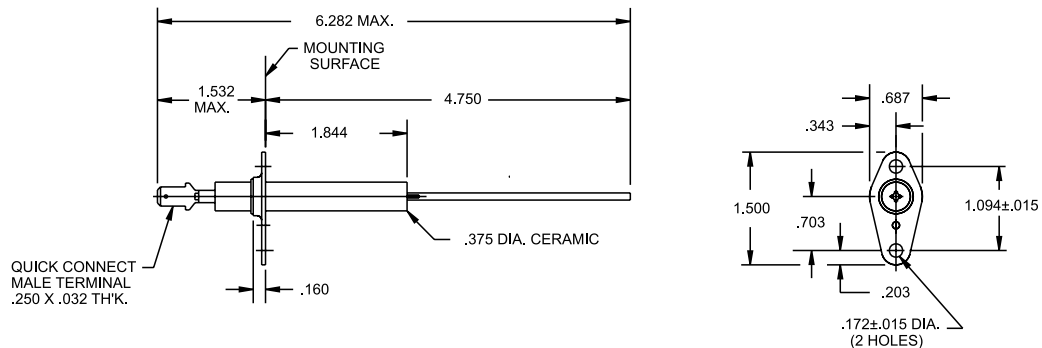

WIRING DIAGRAMS - SERIES 35-65

LOCAL FLAME SENSING (SENSING THROUGH HOT SURFACE IGNITOR)

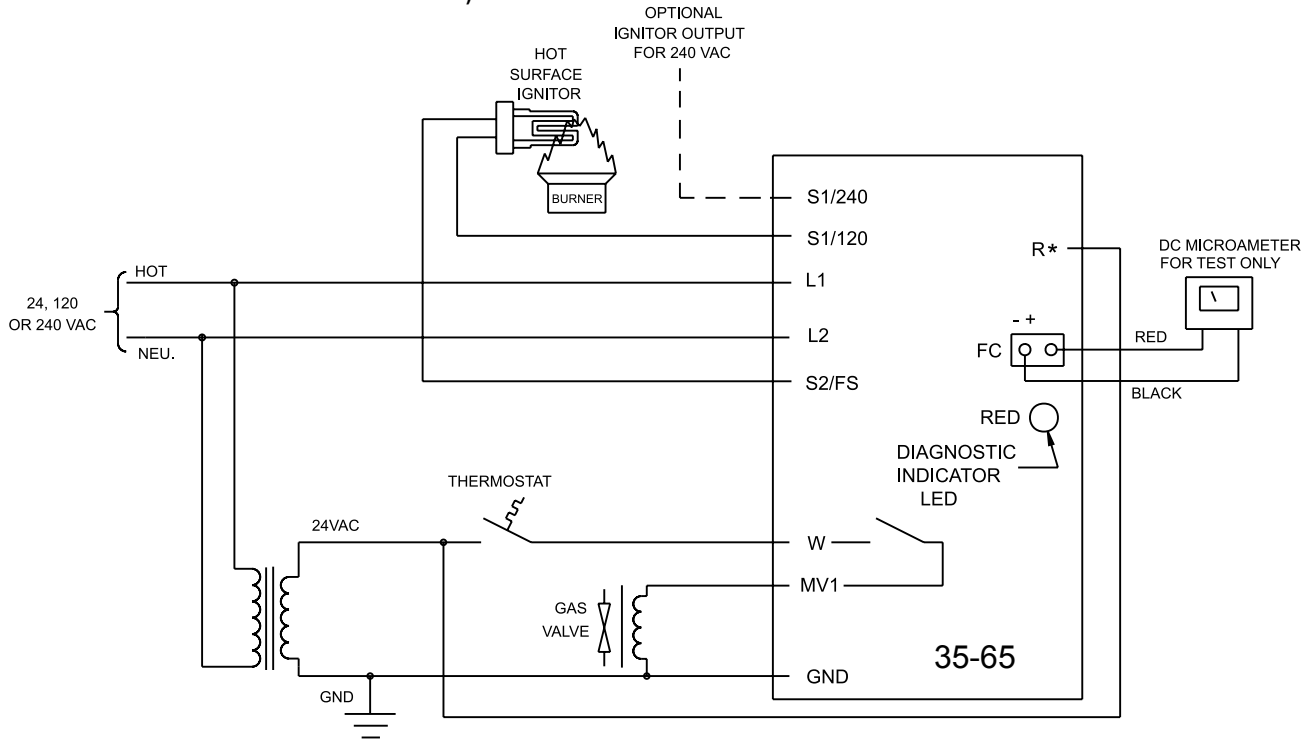

* R TERMINAL IS ONLY USED ON CONTROLS WITH FULL TIME POWER

REMOTE FLAME SENSING (SENSING THROUGH INDEPENDENT FLAME ROD)

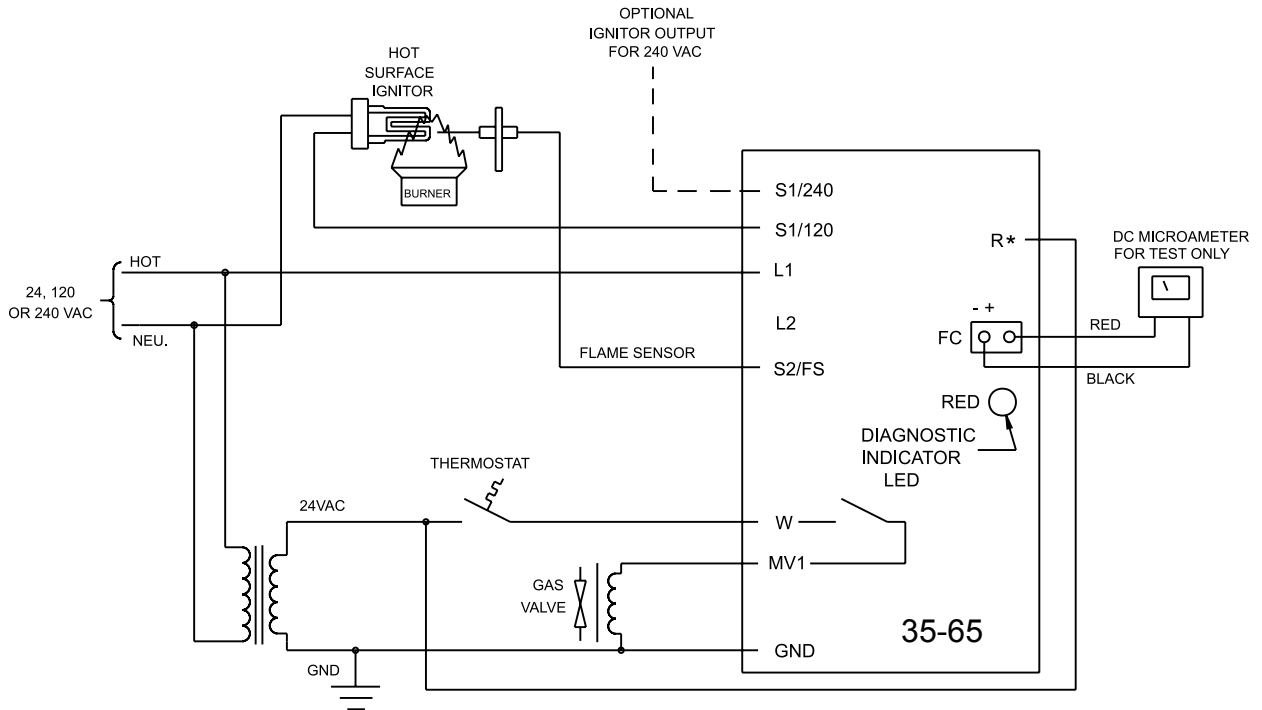

* R TERMINAL IS ONLY USED ON CONTROLS WITH FULL TIME POWER

WIRING DIAGRAMS - SERIES 35-66

LOCAL FLAME SENSING (SENSING THROUGH HOT SURFACE IGNITOR)

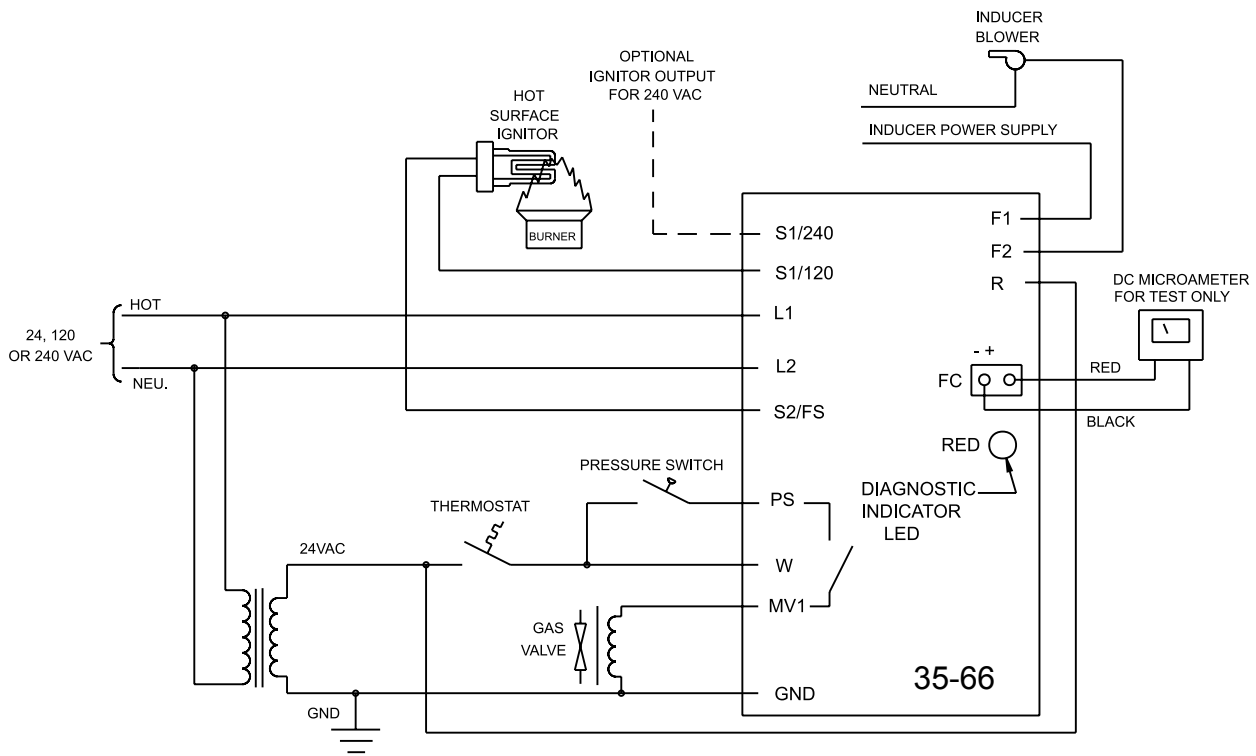

REMOTE FLAME SENSING (SENSING THROUGH INDEPENDENT FLAME ROD)

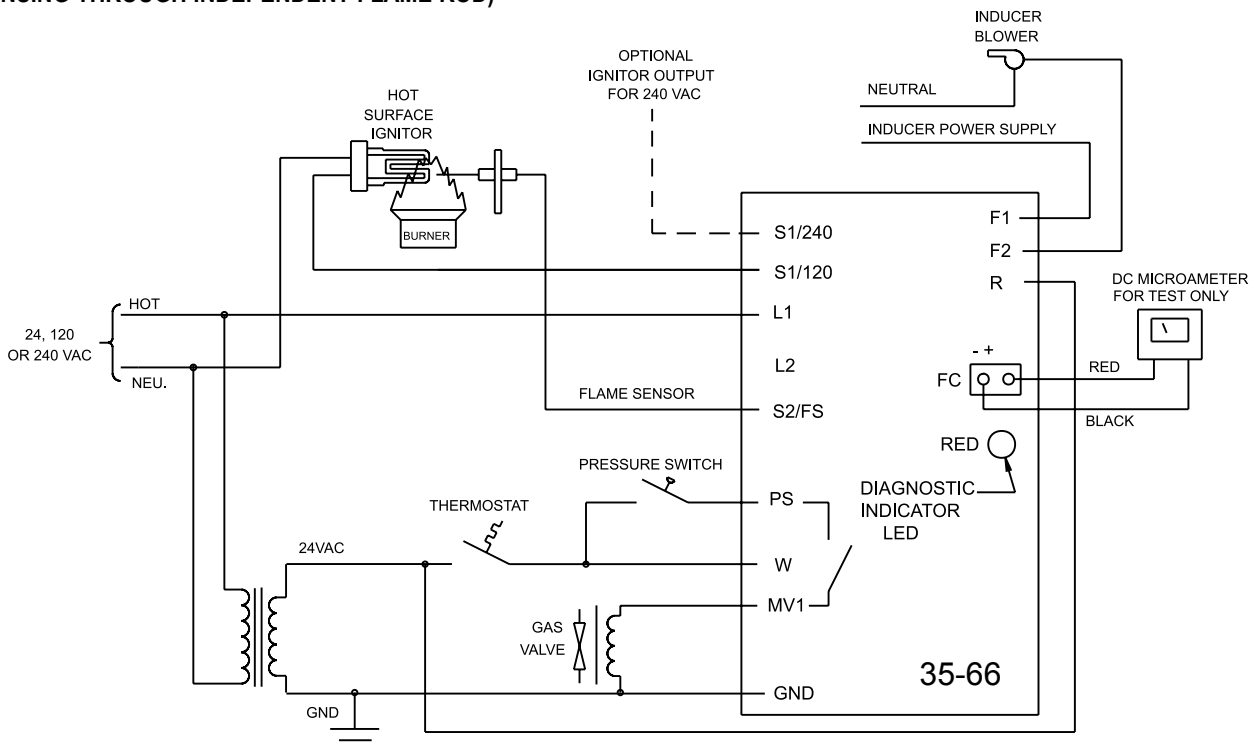

DIMENSIONS - SERIES 35-65, 35-66

FRONT AND SIDE VIEWS

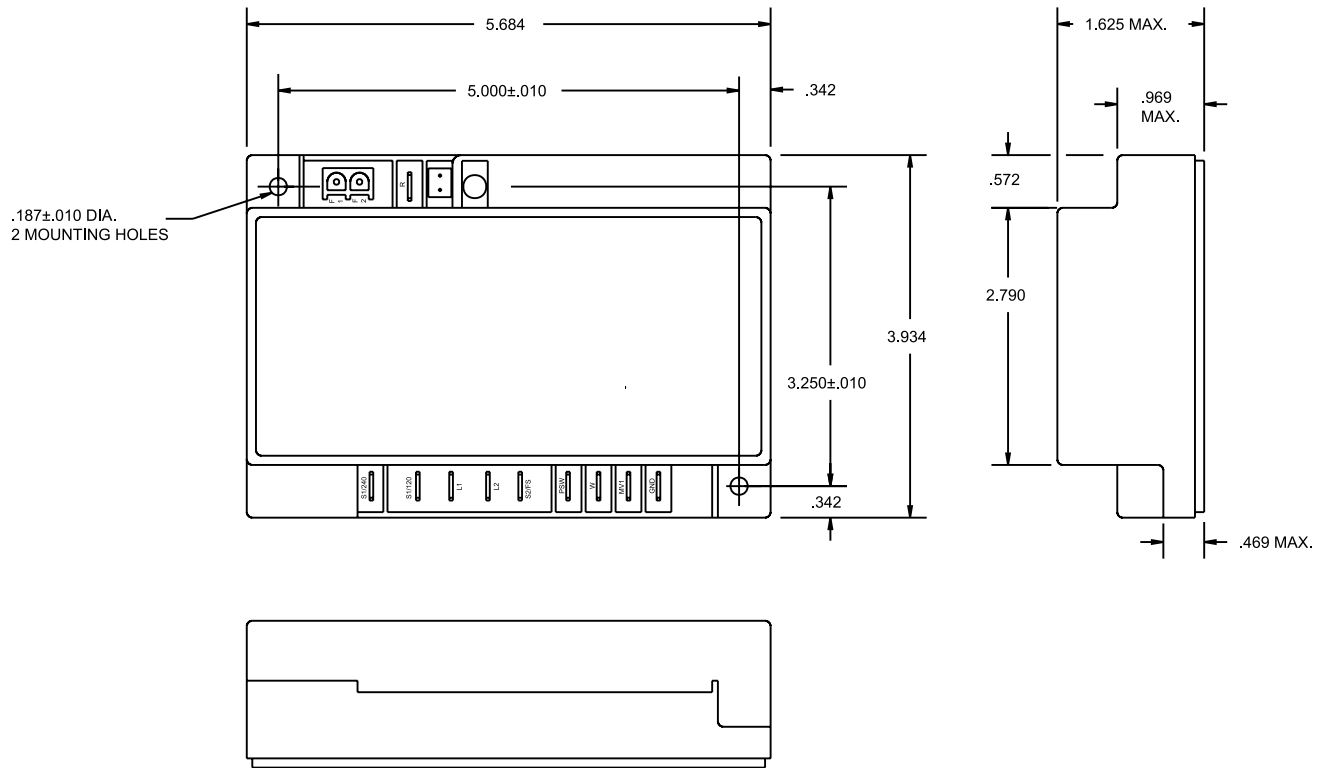

CONTROL CONFIGURATION

35 - 6X X X X X - X X X

Description

Trail For Ignition

- 1 = 4 Seconds
- 3 = 7 Seconds
- 5 = 10 Seconds
- 7 = 15 Seconds

Inter-Purge

- 0 = None
- 1 = 15 Seconds
- 2 = 30 Seconds

Pre-Purge

- 0 = None
- 1 = 15 Seconds
- 2 = 30 Seconds

Tries For Ignition

- 0 = Single Try without Automatic Reset
- 1 = Single Try with 1 Hour Automatic Reset
- 5 = Three Tries without Automatic Reset
- 6 = Three Tries with 1 Hour Automatic Reset

35-65 Only (No Blower Relay) Termination For Models

- 0 = ALL Q.C. Terminals Without Full Time Power (W Only)
- 1 = Mate-N-Loc (5 Pos.) with Q.C. Terminals without Full Time Power (W Only)
- 2 = Mate-N-Loc (2 Pos.) with Q.C. Terminals without Full Time Power (W Only)
- 5 = ALL Q.C. Terminals with Full Time Power (R Terminal)
- 6 = Mate-N-Loc (5 Pos.) with Q.C. Terminals with Full Time Power (R Terminal)

35-66 Only (With Blower Relay) Termination and Post Purge for Models

- 0 = No Post-Purge All Q.C. Terminals without Full Time POWER (W Only)
- 1 = No Post-Purge All Q.C. Terminals with Full Time POWER (R Terminal)
- 2 = 30 Second Post-Purge All Q.C. Terminals *
- 3 = 60 Second Post-Purge All Q.C. Terminals *
- 5 = No Post-Purge Mate-N-Loc (5 Pos.) with Q.C. Terminals without Full Time Power (W Only)
- 6 = No Post-Purge Mate-N-Loc (5 Pos.) with Q.C. Terminals with Full Time Power (R Terminal)
- 7 = 30 Second Post-Purge Mate-N-Loc (5 Pos.) with Q.C. Terminals *
- 8 = 60 Second Post-Purge Mate-N-Loc (5 Pos.) with Q.C. Terminals *

* Post-Purge Requires Full Time Power (R)

Ignitor Options

- 0 = 120/240 VAC Mini-Ignitor (6 Second Heat-Up)
- 2 = 24 VAC Mini-Ignitor (4 Second Heat-Up) CE Approved
- 5 = 120/240 VAC Ignitor (20 Second Heat-Up)
- 6 = 120/240 VAC Ignitor (40 Second Heat-Up)
- 7 = 24 VAC Mini-Ignitor (4 Second Heat-Up)

Custom Designs - Standard Part Number Configuration Does Not Apply

- 3 = Customer Special Features CE Approved (Refer To Drawing)
- 8 = Aftermarket Kit (Refer To Drawing)
- 9 = Customer Special Features (Refer To Drawing)

Optional Features

- 1 = Dual Speed Blower (35-66 Model Only)
- 2 = 120/240 Field Selectable Line Voltage
- 3 = Dual Speed BLOWER AND 120/240 Field Selectable Line Voltage (35-66 Model Only)
- 5 = None

Model

- 5 = Without Combustion Blower Relay (Model 35-65)
- 6 = With Combustion Blower Relay (Model 35-66)



400 MAIN STREET, ASHLAND, MA 01721
 TEL: (508) 881-2000 FAX: (508) 881-6729
 www.fenwalcontrols.com

These instructions do not purport to cover all the details or variations in the equipment described, nor do they provide for every possible contingency to be met in connection with installation, operation and maintenance. All specifications are subject to change without notice. Should further information be desired or should particular problems arise which are not covered sufficiently for the purchaser's purposes, the matter should be referred to KIDDE-FENWAL, Inc., Ashland, Massachusetts.