

HVAC Refrigeration

TUBE & PIPE

- Copper Tube
- Plastic Coated Copper Tube
- Line Sets
- Black Steel Pipe
- Galvanized Steel Pipe
- ABS DWV Pipe

METAL FITTINGS & NIPPLES

- Copper Fittings
- Black & Galvanized Iron Fittings
- Black & Galvanized Steel Nipples
- Brass Fittings & Nipples
- Brass Flare Fittings & Flanges

PLASTIC FITTINGS & NIPPLES

- PVC Sch. 40 Pressure Fittings
- Insert Fittings
- ABS DWV Fittings
- PVC DWV Fittings

VALVES

- Refrigeration Valves
- Plumbing WOG Valves

FILTER-DRIERS & STRAINERS

- Filter Driers
- Strainers



TABLE OF CONTENTS



TUBE & PIPE

Copper Tube	2-3
Plastic Coated Copper Tube	3
Line Sets	5
Black Steel Pipe	6
Galvanized Steel Pipe	6
ABS DWV Pipe	7

METAL FITTINGS & NIPPLES

Copper Fittings	8-29
Black & Galvanized Iron Fittings	30-40
Black & Galvanized Steel Nipples	41-56
Red Brass Fittings & Nipples	57-64
Yellow Brass Fittings & Nipples	65-67
Brass Flare Fittings & Flanges	68-77

PLASTIC FITTINGS & NIPPLES

PVC Sch. 40 Pressure Fittings	78-87
Insert Fittings	88-90
ABS DWV Fittings	91-122
PVC DWV Fittings	123-151

VALVES

Refrigeration Valves	153-166
Plumbing Valves (WOG)	167-179

FILTER-DRIERS & STRAINERS

Filter Driers	179-181
Strainers	182-183

Copper Tube



For decades, Mueller has been producing the best and most trusted copper tube in the industry. The only U.S. manufacturer of both copper tube and copper fittings, Mueller offers a full line of copper tube and coated copper tube products for plumbing, air conditioning, refrigeration, and various other applications. Mueller's ongoing commitment to quality continues to make it the preferred and specified brand of industry professionals.



- Meets applicable ASTM standards B-88, B-306, B-280, B-819
- NSF Approved
- Made in the USA

COPPER TUBE • PLUMBING

NOM	O.D.	Type K			Type L			Type M	DWV	MEDICAL GAS		
		Hard Lengths	Soft Coils	Soft Lengths	Hard Lengths	Soft Coils	Soft Lengths	Hard Lengths	Hard Lengths	Type K Hard Lengths	Type L Hard Lengths	
1/4"	3/8"	10ft, 20ft	60ft, 100ft	10ft, 20ft	10ft, 20ft	60ft, 100ft	10ft, 20ft				10ft, 20ft	10ft, 20ft
3/8"	1/2"	10ft, 20ft	60ft, 100ft	10ft, 20ft	10ft, 20ft	60ft, 100ft	10ft, 20ft	10ft, 20ft			10ft, 20ft	10ft, 20ft
1/2"	5/8"	10ft, 20ft	60ft, 100ft	10ft, 20ft	10ft, 20ft	60ft, 100ft	10ft, 20ft	10ft, 20ft			10ft, 20ft	10ft, 20ft
5/8"	3/4"	10ft, 20ft	60ft, 100ft	10ft, 20ft	10ft, 20ft	60ft, 100ft	10ft, 20ft	10ft, 20ft			10ft, 20ft	10ft, 20ft
3/4"	7/8"	10ft, 20ft	60ft, 100ft	10ft, 20ft	10ft, 20ft	60ft, 100ft	10ft, 20ft	10ft, 20ft			10ft, 20ft	10ft, 20ft
1"	1-1/8"	10ft, 20ft	60ft, 100ft	10ft, 20ft	10ft, 20ft	60ft, 100ft	10ft, 20ft	10ft, 20ft			10ft, 20ft	10ft, 20ft
1-1/4"	1-3/8"	10ft, 20ft	60ft, 100ft	10ft, 20ft	10ft, 20ft	60ft, 100ft	10ft, 20ft	10ft, 20ft	10ft, 20ft		10ft, 20ft	10ft, 20ft
1-1/2"	1-5/8"	10ft, 20ft	60ft, 100ft	10ft, 20ft	10ft, 20ft	60ft, 100ft	10ft, 20ft	10ft, 20ft	10ft, 20ft		10ft, 20ft	10ft, 20ft
2"	2-1/8"	10ft, 20ft	40ft, 60ft	10ft, 20ft	10ft, 20ft	40ft, 60ft	10ft, 20ft	10ft, 20ft	10ft, 20ft		10ft, 20ft	10ft, 20ft
2-1/2"	2-5/8"	10ft, 20ft		10ft, 20ft	10ft, 20ft		10ft, 20ft	10ft, 20ft	10ft, 20ft		10ft, 20ft	10ft, 20ft
3"	3-1/8"	10ft, 20ft		10ft, 20ft	10ft, 20ft		10ft, 20ft	10ft, 20ft	10ft, 20ft		10ft, 20ft	10ft, 20ft
3-1/2"	3-5/8"	10ft, 20ft			10ft, 20ft			10ft, 20ft	10ft, 20ft		10ft, 20ft	10ft, 20ft
4"	4-1/8"	10ft, 20ft			10ft, 20ft			10ft, 20ft	10ft, 20ft		10ft, 20ft	10ft, 20ft
5"	5-1/8"	10ft, 20ft			10ft, 20ft			10ft, 20ft	10ft, 20ft		10ft, 20ft	10ft, 20ft
6"	6-1/8"	10ft, 20ft			10ft, 20ft			10ft, 20ft	10ft, 20ft		10ft, 20ft	10ft, 20ft
8"	8-1/8"	10ft, 20ft			10ft, 20ft			10ft, 20ft	10ft, 20ft		10ft, 20ft	10ft, 20ft

(Nitrogenized thru 3-1/8" Only)

COPPER TUBE • REFRIGERATION

NITROGENIZED® ACR	
O.D.	Hard Lengths
3/8"	10ft, 20ft
1/2"	10ft, 20ft
5/8"	10ft, 20ft
3/4"	10ft, 20ft
7/8"	10ft, 20ft
1-1/8"	10ft, 20ft
1-3/8"	10ft, 20ft
1-5/8"	10ft, 20ft
2-1/8"	10ft, 20ft
2-5/8"	10ft, 20ft
3-1/8"	10ft, 20ft
3-5/8"	10ft, 20ft
4-1/8"	10ft, 20ft
5-1/8"	10ft, 20ft
6-1/8"	10ft, 20ft
8-1/8"	10ft, 20ft

REFRIGERATION SERVICE COILS	
O.D.	Soft Lengths
1/8"	50ft, 100ft
3/16"	50ft, 100ft
1/4"	50ft, 100ft
5/16"	50ft, 100ft
3/8"	50ft, 100ft
1/2"	50ft, 100ft
5/8"	50ft, 100ft
3/4"	50ft, 100ft
7/8"	50ft, 100ft
1-1/8"	50ft, 100ft
1-3/8"	50ft, 100ft
1-5/8"	50ft, 100ft

O.D.	Wall Thickness .025		Wall Thickness .032	
	Hard Lengths	Soft Lengths	Hard Lengths	Soft Lengths
	1/4"	10ft, 20ft	10ft, 20ft	10ft, 20ft

Temperature Control Tube is not recommended for forming or bending purposes.

Temperature Control Tube order quantities are in 2000 ft. per box increments.

COPPER TUBE • PLASTIC COATED

Polyethylene coated copper tube: PlumbShield, GasShield, OilShield, Coated ACR

NOM	OD	Type K			Type L/ACR			Refrigeration Service Coils*
		Hard Lengths	Soft Lengths	Soft Coils	Hard Lengths	Soft Lengths	Soft Coils	Soft Coils
1/4"	3/8"	10ft., 20ft.	10ft., 20ft.	60ft., 100ft.	10ft., 20ft.	10ft., 20ft.	60ft., 100ft.	50ft., 100ft.
3/8"	1/2"	10ft., 20ft.	10ft., 20ft.	60ft., 100ft.	10ft., 20ft.	10ft., 20ft.	60ft., 100ft.	50ft., 100ft.
1/2"	5/8"	10ft., 20ft.	10ft., 20ft.	60ft., 100ft.	10ft., 20ft.	10ft., 20ft.	60ft., 100ft.	50ft., 100ft.
5/8"	3/4"	10ft., 20ft.	10ft., 20ft.	60ft., 100ft.	10ft., 20ft.	10ft., 20ft.	60ft., 100ft.	50ft., 100ft.
3/4"	7/8"	10ft., 20ft.	10ft., 20ft.	60ft., 100ft.	10ft., 20ft.	10ft., 20ft.	60ft., 100ft.	50ft., 100ft.
1"	1-1/8"	10ft., 20ft.	10ft., 20ft.	60ft., 100ft.	10ft., 20ft.	10ft., 20ft.	60ft., 100ft.	50ft., 100ft.
1-1/4"	1-3/8"	10ft., 20ft.	10ft., 20ft.	60ft., 100ft.	10ft., 20ft.	10ft., 20ft.	60ft., 100ft.	
1-1/2"	1-5/8"	10ft., 20ft.	10ft., 20ft.	60ft., 100ft.	10ft., 20ft.	10ft., 20ft.	60ft., 100ft.	
2"	2-1/8"	10ft., 20ft.	10ft., 20ft.	40ft., 60ft.	10ft., 20ft.	10ft., 20ft.	40ft., 60ft.	

PlumbShield™ available in blue and red for water applications and purple for reclaimed water

GasShield™ available in yellow for natural and LP Gas applications

OilShield™ available in orange for fuel and oil applications

Coated ACR available in White for HVAC applications

* Available in OD sizes only



Line Sets



Mueller Line Sets are the industry standard for quality. We leverage our many years of copper tube expertise in every line set we make. From liquid line and suction line handling to unique insulation applications and packaging, every Mueller Line Set meets our tough standards so our customers receive the best line set in the industry. Mueller offers a full line of liquid line and suction line diameters, insulation thicknesses, lengths, custom ends, connections, and other services.



- Copper tubing meets ASTM B-280
- Insulation meets ASTM C-534
- UL 25-50 rated
- Made in the USA

CUSTOM OPTIONS

Mueller offers a full variety of custom lengths, options and connection assemblies to meet customer line set needs.

- Insulated Liquid and Suction Lines for Mini-Split Systems
- Thermostat Wire and Taping
- Custom Ends/Bends
- Flare Nuts, Custom Connections & Assemblies
- Nitrogen & Refrigerant Charged Lines

LINE SET PART # SCHEMATIC

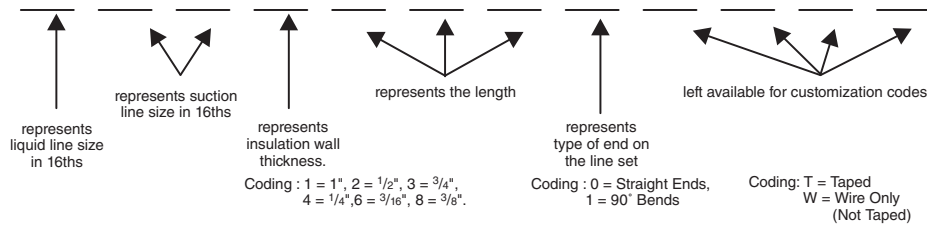

EXAMPLE:

Part # 61280500T186

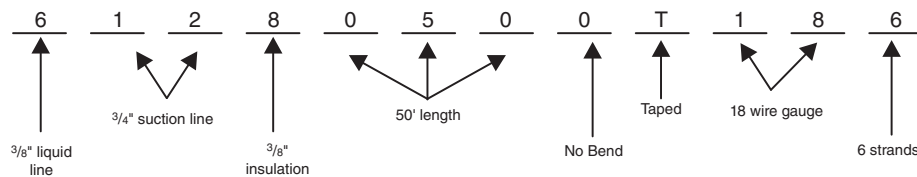

Series No.	LL x SL x INS	QUANTITY PER MASTER CARTON																			
		Standard Line Sets										Mini Split Line Sets									
		10'	15'	20'	25'	30'	35'	40'	45'	50'	60'	10'	15'	20'	25'	30'	35'	40'	45'	50'	60'
406	1/4 x 3/8 x 1/4	14	14	14	14	14	12	12	8	8	7	14	14	14	14	14	12	12	8	8	7
	3/8	14	14	14	14	14	12	12	8	8	7	—	—	—	—	—	—	—	—	—	—
408	1/4 x 1/2 x 1/4	14	14	14	14	14	12	12	8	7	7	—	—	—	—	—	—	—	—	—	—
	3/8	14	14	14	14	14	12	12	8	7	7	14	14	14	14	14	12	12	8	7	7
	1/2	14	14	14	14	12	8	8	8	7	5	14	14	14	14	12	8	8	8	7	5
	3/4	14	14	8	8	7	7	5	4	4	4	14	14	8	8	7	7	5	4	4	4
410	1/4 x 5/8 x 1/4	14	14	14	14	12	8	8	8	8	7	14	14	14	14	12	8	8	8	8	7
	3/8	14	14	14	14	12	8	8	8	8	7	—	—	—	—	—	—	—	—	—	—
	1/2	14	14	12	12	8	8	8	7	7	5	14	14	12	12	8	8	8	7	7	5
	3/4	12	12	12	8	7	7	7	7	5	5	12	12	12	8	7	7	7	7	5	5
510	5/16 x 5/8 x 1/4	14	14	14	14	12	8	8	8	8	7	—	—	—	—	—	—	—	—	—	—
	3/8	14	14	14	14	12	8	8	8	8	7	14	14	14	14	12	8	8	8	8	7
	1/2	14	14	12	12	8	8	8	7	7	5	14	14	12	12	8	8	8	7	7	5
	3/4	12	12	12	8	8	8	8	7	5	5	12	12	12	8	8	8	8	7	5	5
610	3/8 x 5/8 x 1/4	14	14	14	14	12	8	8	8	8	7	—	—	—	—	—	—	—	—	—	—
	3/8	14	14	14	14	12	8	8	8	8	7	14	14	14	14	12	8	8	8	8	7
	1/2	14	14	12	12	8	8	8	7	7	5	14	14	12	12	8	8	8	7	7	5
	3/4	12	12	12	7	7	5	5	5	5	5	12	12	12	7	7	5	5	5	5	5
412	1/4 x 3/4 x 1/4	14	14	14	12	12	8	8	7	7	5	—	—	—	—	—	—	—	—	—	—
	3/8	14	14	14	12	12	8	8	7	7	5	14	14	14	12	12	8	8	7	7	5
	1/2	14	14	12	8	8	7	7	5	5	4	14	14	12	8	8	7	7	5	5	4
	3/4	12	8	8	8	5	5	5	4	4	4	12	8	8	8	5	5	5	4	4	4
512	5/16 x 3/4 x 1/4	14	14	14	12	12	8	8	7	7	5	—	—	—	—	—	—	—	—	—	—
	3/8	14	14	14	12	12	8	8	7	7	5	14	14	14	12	12	8	8	7	7	5
	1/2	14	14	12	8	8	7	7	5	5	4	14	14	12	8	8	7	7	5	5	4
	3/4	12	8	8	8	5	5	5	4	4	4	12	8	8	8	5	5	5	4	4	4
612	3/8 x 3/4 x 1/4	14	14	14	12	12	8	8	7	7	5	—	—	—	—	—	—	—	—	—	—
	3/8	14	14	14	12	12	8	8	7	7	5	14	14	14	12	12	8	8	7	7	5
	1/2	14	14	12	8	8	7	7	5	5	4	14	14	12	8	8	7	7	5	5	4
	3/4	12	8	8	8	5	5	5	4	4	4	12	8	8	8	5	5	5	4	4	4
	1	—	—	—	—	—	—	—	—	—	—	12	8	8	8	5	5	5	4	4	4
614	3/8 x 7/8 x 1/4	14	14	12	12	8	8	8	7	7	5	—	—	—	—	—	—	—	—	—	—
	3/8	14	14	12	12	8	8	8	7	7	5	14	14	12	12	8	8	8	7	7	5
	1/2	14	12	8	8	7	7	5	5	5	4	14	12	8	8	7	7	5	5	5	4
	3/4	12	8	8	7	5	5	4	4	4	4	12	8	8	7	5	5	4	4	4	4
	1	—	—	—	—	—	—	—	—	—	—	12	8	8	7	5	5	4	4	4	4
618	3/8 x 1-1/8 x 1/4	8	8	8	8	7	7	5	5	5	N/A	—	—	—	—	—	—	—	—	—	—
	3/8	8	8	8	8	7	7	5	5	5	N/A	8	8	8	8	7	7	5	5	5	5
	1/2	8	8	8	8	7	5	5	4	4	N/A	8	8	8	8	7	5	5	4	4	4
	3/4	8	7	7	7	5	4	4	4	4	N/A	8	7	7	7	5	4	4	4	4	4
	1	—	—	—	—	—	—	—	—	—	—	8	7	7	7	5	4	4	4	4	4

Mini Split Line Sets
 LL- Liquid Line
 SL- Suction Line
 INS- Insulation

TUBE & PIPE

METAL FITTINGS & NIPPLES

PLASTIC FITTINGS

VALVES

FILTER-DRIERS & STRAINERS



Steel Pipe



Mueller provides an impressive line of black steel and galvanized steel pipe products that are manufactured to rigid industry standards and backed by Mueller's trusted name and assurance of quality. Our standard welded steel pipe is available in 1/4" - 4" diameters and offered in either 10 foot or 21 foot cut lengths. Mueller Steel Pipe is available in either plain, threaded, or threaded and coupled ends.



- Threads comply with ANSI B1.20.1
- Pipe complies with ANSI/ASTM A.733, A53
- NAFTA approved

10 FT THREADED STEEL PIPE

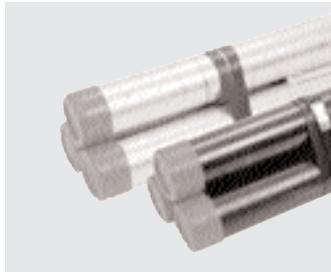

GALVANIZED	BLACK	Size	Weight Approx. (Lbs.)	Pieces Per Bundle	Master Wt. (Lbs.)
10424	20424	1/2" x 10'	8.5319	5	43
10524	20524	3/4" x 10'	11.3538	5	57
10624	20624	1" x 10'	16.7970	3	50
10724	20724	1-1/4" x 10'	22.7760	3	68
10824	20824	1-1/2" x 10'	27.2117	3	82
10924	20924	2" x 10'	36.5504	2	73
11024	21024	2-1/2" x 10'	57.9838	18	-
11124	21124	3" x 10'	75.8567	14	-
11224	21224	4" x 10'	107.9714	10	-

21 FT PLAIN END & BEVELED STEEL PIPE

GALVANIZED	BLACK	Size	Weight Approx. (Lbs.)	Pieces Per Bundle	Master Wt. (Lbs.)
10430LB	20430LB	1/2" x 21'	17.9192	5	90
10530LB	20530LB	3/4" x 21'	23.8452	5	119
10630LB	20630LB	1" x 21'	35.2740	3	106
10730LB	20730LB	1-1/4" x 21'	47.8315	3	143
10830LB	20830LB	1-1/2" x 21'	57.1438	3	171
10930LB	20930LB	2" x 21'	76.7562	2	154
11030LB	21030LB	2-1/2" x 21'	121.7657	18	-
11130LB	21130LB	3" x 21'	159.2972	14	-
11230LB	21230LB	4" x 21'	226.7411	10	-

21 FT THREADED & COUPLED STEEL PIPE

GALVANIZED	BLACK	Size	Weight Approx. (Lbs.)	Pieces Per Bundle	Master Wt. (Lbs.)
10430C	20430C	1/2" x 21'	17.9192	5	90
10530C	20530C	3/4" x 21'	23.8452	5	119
10630C	20630C	1" x 21'	35.2740	3	106
10730C	20730C	1-1/4" x 21'	47.8315	3	143
10830C	20830C	1-1/2" x 21'	57.1438	3	171
10930C	20930C	2" x 21'	76.7562	2	154
11030C	21030C	2-1/2" x 21'	121.7657	18	-
11130C	21130C	3" x 21'	159.2972	14	-
11230C	21230C	4" x 21'	226.7411	10	-

ABS DWV Pipe



Mueller's modern manufacturing technology provides a consistent and dense cellular structure while also ensuring a uniform pipe wall. Our unique and precise processes create ABS DWV Pipe at the highest quality levels. This means uncompromising and reliable performance for our customers.

- Smooth and consistent interior wall provides for full flow, resistance to corrosion or scaling
- Smooth and consistent exterior wall provides for easy and reliable joining, joint performance, and attractive appearance
- Dense and uniform cellular (foam) structure provides, reliable, strong, and quiet product
- Uniform interior and exterior wall skin for a strong and reliable joint
- 25 year warranty



- TUBE & PIPE
- METAL FITTINGS & NIPPLES
- PLASTIC FITTINGS
- VALVES
- FILTER-DRIERS & STRAINERS

ABS DWV PIPE

ABS DWV PIPE – 10 FT

ABS DWV Schedule 40 Cellular Core, Plain End, Black, ASTM F-628						
Nom. Size	Length	Part Number	Feet Per Lift	Pieces Per Lift	Weight (lbs.) Per 100 ft.	Truckload % Per Lift
1-1/2"	10 ft.	APC015010	2590	259	27.3	2.5
2"	10 ft.	APC020010	1670	167	37.8	2.5
3"	10 ft.	APC030010	750	75	74.5	2.5
4"	10 ft.	APC040010	480	48	103.9	2.5
6"	10 ft.	APC060010	180	18	186.9	2.5

ABS DWV PIPE – 20 FT

ABS DWV Schedule 40 Cellular Core, Plain End, Black, ASTM F-628						
Nom. Size	Length	Part Number	Feet Per Lift	Pieces Per Lift	Weight (lbs.) Per 100 ft.	Truckload % Per Lift
1-1/2"	20 ft.	APC015020	5,180	259	27.3	5
2"	20 ft.	APC020020	3,340	167	37.8	5
3"	20 ft.	APC030020	1,500	75	74.5	5
4"	20 ft.	APC040020	960	48	103.9	5
6"	20 ft.	APC060020	360	18	186.9	5



WROT & CAST Copper Fittings



TUBE & PIPE

METAL FITTINGS
& NIPPLES

PLASTIC
FITTINGS

VALVES

FILTER-DRYERS
& STRAINERS

In 1930, Mueller invented and pioneered the now famous Streamline solder type copper fitting. This development led to making all copper plumbing the standard of the industry. Today, Mueller offers one of the industry's most complete lines of copper products from one source. Included are wrot and cast pressure and DWV fittings. Mueller's many years of engineering know how and experience is reflected in the fine quality and workmanship of each copper fitting.



- Meet applicable ANSI/ASME standards B1.6.22, B1.6.29, B1.6.18, B1.6.15, B1.6.26, B1.6.24, B1.6.23
- NSF Approved
- Made in the USA

ADAPTER • FEMALE

COPPER FITTING

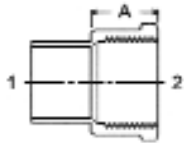

CONNECTION C x F

I	MUELLER STYLE WC-402		Part Number	ELKHART STYLE 103		Approx. Net.Wt.	NIBCO STYLE 9603		
	Size 2	3		Box Qty.	Master Qty.		Dimensions A	B	C
REDUCING									
	1/4" x 1/2"		W 01204	100	300	.1	15/64		
	1/4" x 3/8"		W 01205	100	700	.05	5/8		
	1/4" x 1/4"		W 01206	100	900	.04	21/32		
	1/4" x 1/8"		W 01207	100	1,500	.04	9/16		
	3/8" x 3/8"		W 01214	50	1,000	.06	21/32		
	3/8" x 1/4"		W 01215	50	750	.04	5/8		
	3/8" x 1/8"		W 01216	100	1,500	.03	17/32		
	1/2" x 3/4"		W 01223	50	300	.16	13/16		
	1/2" x 1/2"		W 01224	50	500	.10	1		
	1/2" x 3/8"		W 01225	50	750	.07	53/64		
	1/2" x 1/4"		W 01226	50	750	.06	19/32		
	5/8" x 3/4"		W 01230	25	250	.15	1-3/64		
	5/8" x 1/2"		W 01231	50	500	.10	27/32		
	5/8" x 3/8"		W 01232	50	500	.07	49/64		
	5/8" x 1/4"		W 01233	50	500	.06	1/2		
	3/4" x 3/4"		W 01238	50	500	.15	57/64		
	3/4" x 1/2"		W 01239	50	500	.09	29/32		
	7/8" x 1"		W 01245	25	250	.27	1-5/32		
	7/8" x 3/4"		W 01246	25	250	.22	13/16		
	7/8" x 1/2"		W 01247	25	250	.11	1		
	1-1/8" x 1-1/4"		W 01261	10	100	.28	1-7/32		
	1-1/8" x 1"		W 01263	25	250	.24	31/32		





ADAPTER • FEMALE continued

COPPER FITTING

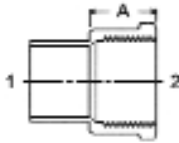

CONNECTION
C x F

I	Size		Part Number	Box Qty.	Master Qty.	Approx. Net.Wt.	Dimensions		
	2	3					A	B	C
REDUCING									
	1-1/8"	3/4"	W 01264	25	250	.22	13/16		
	1-1/8"	1/2"	W 01265	20	200	.25	23/32		
	1-3/8"	1-1/2"	W 01270	10	100	.5	1-13/32		
	1-3/8"	1-1/4"	W 01271	10	100	.45	1-7/32		
	1-3/8"	1"	W 01272	10	100	.33	1		
	1-5/8"	2"	W 01278	-	60	.74	1-7/32		
	1-5/8"	1-1/2"	W 01279	10	100	.53	1-1/4		
	1-5/8"	1-1/4"	W 01280	5	50	.39	29/32		
	2-1/8"	2"	W 01287	-	50	.57	15/16		
	2-1/8"	1-1/2"	W 01288	5	50	.74	1-3/16		
	2-5/8"	2-1/2"	W 01296	-	25	1.22	1-3/16		
	3-1/8"	3"	W 01297	-	15	1.83	1-5/16		

ADAPTER • FITTING

COPPER FITTING

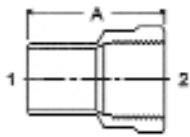

CONNECTION
FTG x F

I	Size		Part Number	Box Qty.	Master Qty.	Approx. Net.Wt.	Dimensions		
	2	3					A	B	C
REDUCING									
	3/8"	3/8"	W 01514	50	750	.06	1-9/32		
	1/2"	1/2"	W 01524	50	350	.1	1-15/32		
	1/2"	3/8"	W 01525	50	750	.05	1-19/64		
	1/2"	1/4"	W 01526	50	750	.06	1-1/8		
	5/8"	1/2"	W 01531	50	450	.11	1-1/2		
	5/8"	3/8"	W 01532	50	750	.07	1-19/64		
	7/8"	3/4"	W 01546	25	250	.17	1-45/64		
	7/8"	1/2"	W 01547	50	500	.11	1-11/16		
	1-1/8"	1"	W 01563	25	250	.24	2-5/64		
	1-1/8"	3/4"	W 01564	25	250	.18	1-49/64		
	1-3/8"	1-1/4"	W 01571	10	100	.4	2-7/32		
	1-5/8"	1-1/2"	W 01579	10	100	.46	2-15/32		
	2-1/8"	2"	W 01587	-	50	.65	2-13/32		
	2-5/8"	2-1/2"	W 01596	-	25	1.2	2-53/64		

ADAPTER • MALE

COPPER FITTING

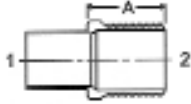
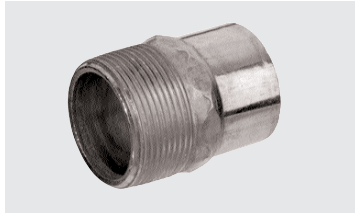

CONNECTION
C x M

MUELLER STYLE
WC-401

ELKHART STYLE
104

NIBCO STYLE
9604

1	Size		Part Number	Box Qty.	Master Qty.	Approx. Net.Wt.	Dimensions		
	2	3					A	B	C
REDUCING									
	1/4" x 3/8"		W 01105	50	1000	.06	3/4		
	1/4" x 1/4"		W 01106	50	1,200	.03	49/64		
	1/4" x 1/8"		W 01107	50	1,000	.02	27/64		
	5/16" x 1/8"		W 01109*	50	800	.07	27/32		
	5/16" x 1/4"		W 01110*	50	1,200	.03	5/8		
	1/4" x 1/2"		W 01113	50	500	.08	1		
	3/8" x 1/2"		W 01113	50	500	.08	1		
	3/8" x 3/8"		W 01114	50	1,000	.06	63/64		
	3/8" x 1/4"		W 01115	50	1,200	.03	21/32		
	3/8" x 1/8"		W 01116	50	1,000	.02	17/32		
	1/2" x 3/4"		W 01123	25	250	.17	1-7/64		
	1/2" x 1/2"		W 01124	50	500	.09	13/16		
	1/2" x 3/8"		W 01125	50	500	.06	21/32		
	1/2" x 1/4"		W 01126	50	750	.05	7/8		
	5/8" x 1"		W 01129	15	150	.3	1-29/64		
	5/8" x 3/4"		W 01130	25	250	.16	15/16		
	5/8" x 1/2"		W 01131	50	500	.08	13/16		
	5/8" x 3/8"		W 01132	50	500	.07	41/64		
	5/8" x 1/4"		W 01133	25	600	.06	3/4		
	3/4" x 3/4"		W 01138	25	250	.14	1-1/64		
	3/4" x 1/2"		W 01139	10	100	.12	3/4		
	7/8" x 1"		W 01145	10	100	.29	1-5/32		
	7/8" x 3/4"		W 01146	25	250	.14	1-15/32		
	7/8" x 1/2"		W 01147	25	250	.12	7/8		
	1-1/8" x 1-1/2"		W 01161	10	100	.48	1-45/64		
	1-1/8" x 1-1/4"		W 01162	10	100	.39	1-9/16		
	1-1/8" x 1"		W 01163	10	100	.24	1-9/64		
	1-1/8" x 3/4"		W 01164	10	100	.17	59/64		
	1-1/8" x 1/2"		W 01165	25	250	.18	31/32		
	1-3/8" x 1-1/2"		W 01170	10	100	.48	1-21/32		
	1-3/8" x 1-1/4"		W 01171	10	100	.41	1-9/32		
	1-3/8" x 1"		W 01172	10	100	.24	2-1/4		
	1-3/8" x 3/4"		W 01173	10	100	.21	31/32		
	1-5/8" x 2"		W 01178	-	50	.78	1-7/32		
	1-5/8" x 1-1/2"		W 01179	10	100	.51	1-1/4		
	1-5/8" x 1-1/4"		W 01180	10	100	.37	1-1/8		
	1-5/8" x 1"		W 01181	10	100	.38	1-3/32		
	2-1/8" x 2"		W 01187	5	50	.57	1-19/64		
	2-1/8" x 1-1/2"		W 01188	-	50	.64	1-3/32		
	2-1/8" x 1-1/4"		W 01189	-	50	.57	1-5/32		
	2-5/8" x 2-1/2"		W 01196	-	20	1.26	1-21/32		
	2-5/8" x 2"		W 01197	-	20	.98	1-1/8		
	2-5/8" x 1-1/2"		W 01198	-	22	.98	1-7/32		
	3-1/8" x 3"		W 01199	-	20	1.7	1-27/64		
	4-1/8" x 4"		W 01150	-	16	3.71	1-29/32		

TUBE & PIPE

METAL FITTINGS & NIPPLES

PLASTIC FITTINGS

VALVES

FILTER-DRIERS & STRAINERS



ADAPTER • FITTING

COPPER FITTING

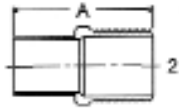

**CONNECTION
C x C**

I	Size		Part Number	Box Qty.	Master Qty.	Approx. Net.Wt.	Dimensions					
	2	3					A	B	C			
							<table border="1"> <thead> <tr> <th>MUELLER STYLE WC-400NS</th> <th>ELKHART STYLE 101</th> <th>NIBCO STYLE 9601</th> </tr> </thead> </table>			MUELLER STYLE WC-400NS	ELKHART STYLE 101	NIBCO STYLE 9601
MUELLER STYLE WC-400NS	ELKHART STYLE 101	NIBCO STYLE 9601										
	3/8" x 3/8"		W 01414	50	750	.06	1-1/4					
	1/2" x 3/8"		W 01425	50	1000	.04	1-1/4					
	5/8" x 1/2"		W 01431	50	500	.09	1-3/8					
	5/8" x 3/8"		W 01432	50	1000	.06	1-11/32					
	7/8" x 3/4"		W 01446	50	500	.15	1-59/64					
	7/8" x 1/2"		W 01447	25	250	.13	1-23/32					
	1-1/8" x 1"		W 01463	25	250	.23	2-1/4					
	1-1/8" x 3/4"		W 01464	25	250	.19	2-3/64					
	1-3/8" x 1-1/4"		W 01471	10	100	.41	2-15/32					
	1-5/8" x 1-1/2"		W 01479	10	100	.49	2-19/32					
	2-1/8" x 2"		W 01487	-	50	.76	2-49/64					
	2-5/8" x 2-1/2"		W 01496	-	25	1.95	3-3/8					

BUSHING • FLUSH

COPPER FITTING

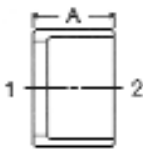

**CONNECTION
FTG x C**

I	Size		Part Number	Box Qty.	Master Qty.	Approx. Net.Wt.	Dimensions					
	2	3					A	B	C			
							<table border="1"> <thead> <tr> <th>MUELLER STYLE WC-106</th> <th>ELKHART STYLE 119</th> <th>NIBCO STYLE 9618</th> </tr> </thead> </table>			MUELLER STYLE WC-106	ELKHART STYLE 119	NIBCO STYLE 9618
MUELLER STYLE WC-106	ELKHART STYLE 119	NIBCO STYLE 9618										
	3/8" x 1/4"		W 01706	100	3,400	.01	3/8					
	1/2" x 3/8"		W 01712	100	3,400	.01	7/16					
	1/2" x 1/4"		W 01714	100	2,400	.02	7/16					
	5/8" x 1/2"		W 01715	100	1,500	.02	9/16					
	5/8" x 3/8"		W 01717	100	1,500	.04	9/16					
	3/4" x 5/8"		W 01720	50	750	.03	11/16					
	3/4" x 1/2"		W 01721	50	750	.06	11/16					
	3/4" x 3/8"		W 01722	50	750	.08	11/16					
	7/8" x 3/4"		W 01725	50	500	.04	13/16					
	7/8" x 5/8"		W 01726	50	500	.07	13/16					
	7/8" x 1/2"		W 01727	50	500	.11	13/16					
	1-1/8" x 7/8"		W 01737	25	250	.12	31/32					
	1-1/8" x 3/4"		W 01738	50	500	.18	31/32					
	1-1/8" x 5/8"		W 01739	25	250	.22	31/32					
	1-3/8" x 1-1/8"		W 01743	10	200	.16	1-1/32					
	1-3/8" x 7/8"		W 01745	10	200	.30	1-1/32					
	1-5/8" x 1-3/8"		W 01750	10	100	.22	1-5/32					
	1-5/8" x 1-1/8"		W 01751	10	100	.41	1-5/32					
	2-1/8" x 1-5/8"		W 01758	10	100	.68	1-13/32					
	2-1/8" x 1-3/8"		W 01759	5	50	.94	1-13/32					
	2-5/8" x 2-1/8"		W 01767	-	50	.92	1-17/32					

TUBE & PIPE

METAL FITTINGS & NIPPLES

PLASTIC FITTINGS

VALVES

FILTER-DRIERS & STRAINERS



BUSHING • FLUSH

COPPER FITTING

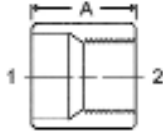

CONNECTION
FTG x F

I	Size		Part Number	Box Qty.	Master Qty.	Approx. Net.Wt.	Dimensions		
	2	3					A	B	C
			A 07812*	100	1,600	.04	17/32		
			A 07813*	50	1,200	.02	9/16		
			A 07814*	50	600	.08	13/16		
			A 07815*	50	300	.17	31/32		
			A 07816*	10	160	.25	1-3/64		
			A 07817*	10	120	.34	1-5/64		
			A 07819*	10	60	.48	1-13/32		

CAP

COPPER FITTING



CONNECTION
C

I	Size		Part Number	Box Qty.	Master Qty.	Approx. Net.Wt.	Dimensions		
	2	3					A	B	C
			W 07002	50	2,000	.00	1/32		
			W 07004	50	2,000	.01	3/32		
			W 07006	50	1,000	.01	3/32		
			W 07007	50	1,000	.02	1/32		
			W 07008	50	1,000	.03	1/8		
			W 07009	25	1,000	.04	3/64		
			W 07011	10	500	.07	3/64		
			W 07012	25	250	.11	3/64		
			W 07013	25	250	.18	1/16		
			W 07014	-	100	.30	1/16		
			W 07015	-	50	.48	5/64		
			W 07016	-	50	.73	5/64		
			W 07017	-	25	1.15	3/32		
			W 07018	-	20	1.5	7/64		

COUPLING • NO STOP

COPPER FITTING



CONNECTION
C x C

I	Size		Part Number	Box Qty.	Master Qty.	Approx. Net.Wt.	Dimensions		
	2	3					A	B	C
			W 01900	100	3,400	.01			
			W 01901	50	1,700	.01			
			W 01902	50	1,700	.01			
			W 01903	100	1,000	.03			
			W 01904	25	375	.04			
			W 01905	50	500	.06			
			W 01906	25	250	.11			

COUPLING • NO STOP continued

COPPER FITTING

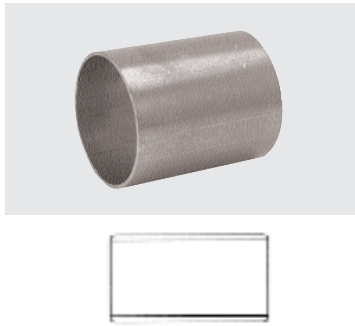

I	Size		Part Number	Box Qty.	Master Qty.	Approx. Net.Wt.	CONNECTION C x C				
	2	3					MUELLER STYLE WC-400NS	ELKHART STYLE 101	NIBCO STYLE 9601	Dimensions	
										A	B
	1-3/8"		W 01907	25	250	.15					
	1-5/8"		W 01908	10	100	.25					
	2-1/8"		W 01909	-	75	.4					
	2-5/8"		W 01910	-	50	.66					
	3-1/8"		W 01911	-	25	1.03					
	4-1/8"		W 01913	-	15	2.15					

COUPLING • ROLLED STOP

COPPER FITTING

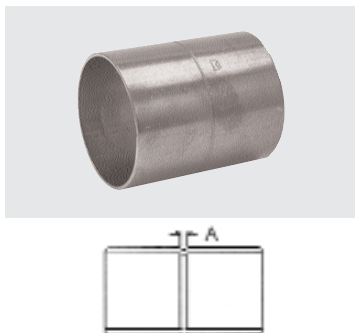

I	Size		Part Number	Box Qty.	Master Qty.	Approx. Net.Wt.	CONNECTION C x C				
	2	3					MUELLER STYLE WC-400	ELKHART STYLE 100-RS	NIBCO STYLE 9600-RS	Dimensions	
										A	B
	1/8"		W 01000	100	4,000	-	3/64				
	3/16"		W 01001	100	4,000	-	1/16				
	1/4"		W 01003	100	4,000	-	1/16				
	3/8"		W 01009	50	2,000	.01	1/16				
	1/2"		W 01017	50	1,700	.01	1/16				
	5/8"		W 01022	50	1,000	.02	1/16				
	3/4"		W 01028	25	500	.05	1/16				
	7/8"		W 01034	25	500	.06	1/16				
	1"		W 01040	25	250	.10	1/16				
	1-1/8"		W 01047	10	250	.10	1/16				
	1-3/8"		W 01055	25	250	.15	1/16				
	1-1/2"		W 01062	-	150	.22	1/16				
	1-5/8"		W 01063	10	100	.22	1/16				
	2-1/8"		W 01072	-	75	1.40	1/16				
	2-5/8"		W 01082	-	50	.68	3/16				
	3-1/8"		W 01092	-	25	1.05	3/16				
	3-5/8"		W 10100	-	20	1.18	3/16				
	4-1/8"		W 10107	-	15	2.11	3/16				

COUPLING • STAKED STOP

COPPER FITTING

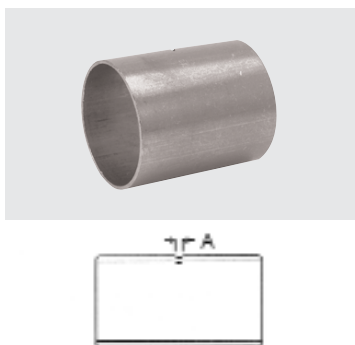

I	Size		Part Number	Box Qty.	Master Qty.	Approx. Net.Wt.	CONNECTION C x C				
	2	3					MUELLER STYLE WC-400S	ELKHART STYLE 100	NIBCO STYLE 9600-DS	Dimensions	
										A	B
	1/4		W 10141	100	4,000	.01	1/16				
	5/16		W 10142	100	5,600	.01	1/16				
	3/8		W 10143	50	2,000	.01	1/16				
	1/2		W 10144	50	1,700	.02	1/16				
	5/8		W 10145	100	1,000	.03	1/16				
	3/4		W 10157	25	500	.04	1/16				
	7/8		W 10146	50	500	.06	1/16				

TUBE & PIPE

METAL FITTINGS & NIPPLES

PLASTIC FITTINGS

VALVES

FILTER-DRIERS & STRAINERS



COUPLING • STAKED STOP continued

COPPER FITTING

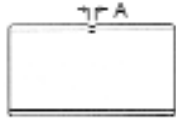

I	CONNECTION		Part Number	Box Qty.	Master Qty.	Approx. Net.Wt.	Dimensions		
	C x C						A	B	C
	Size 2	Size 3							
	MUELLER STYLE WC-400S								
	ELKHART STYLE 100								
	NIBCO STYLE 9600-DS								
	1-1/8"		W 10147	25	250	.11	1/16		
	1-3/8"		W 10148	25	250	.15	1/16		
	1-5/8"		W 10149	10	100	.22	1/16		
	2-1/8"		W 10150	-	75	.41	1/16		
	2-5/8"		W 10151	-	50	.66	3/16		
	3-1/8"		W 10152	-	25	1.02	3/16		
	3-5/8"		W 10153	-	20	1.03	3/16		
	4-1/8"		W 10154	-	15	2.15	3/16		
	5-1/8"		W 10155	-	8	3.34	3/16		
	6-1/8"		W 10156	-	3	4.61	3/16		
	8-1/8"		W 10130	-	1	14.13	7/16		

COUPLING • REDUCING

COPPER FITTING

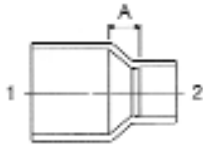
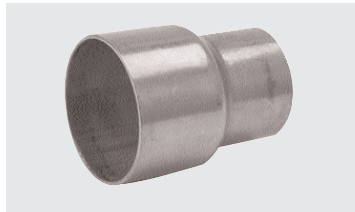

I	CONNECTION		Part Number	Box Qty.	Master Qty.	Approx. Net.Wt.	Dimensions		
	C x C						A	B	C
	Size 2	Size 3							
	MUELLER STYLE WC-400R								
	ELKHART STYLE 101-R								
	NIBCO STYLE 9600								
	1/4" x 3/16"		W 01004	50	2,000	.01	5/32		
	1/4" x 1/8"		W 01005	50	2,000	.00	3/16		
	3/8" x 5/16"		W 01010	50	2,000	.01	3/32		
	3/8" x 1/4"		W 01011	50	1,700	.01	3/16		
	1/2" x 3/8"		W 01019	50	1,700	.02	7/32		
	1/2" x 1/4"		W 01021	50	1,200	.02	3/8		
	5/8" x 1/2"		W 01023	100	1,000	.03	1/8		
	5/8" x 3/8"		W 01025	100	1,000	.03	19/64		
	5/8" x 1/4"		W 01027	100	1,000	.03	23/64		
	3/4" x 5/8"		W 01029	100	600	.05	1/4		
	3/4" x 1/2"		W 01030	100	600	.04	3/16		
	3/4" x 3/8"		W 01031	100	600	.04	5/16		
	7/8" x 3/4"		W 01035	100	1,000	.06	13/64		
	7/8" x 5/8"		W 01036	50	500	.08	19/64		
	7/8" x 1/2"		W 01037	50	500	.06	13/32		
	7/8" x 3/8"		W 01038	50	500	.06	3/8		
	1-1/8" x 7/8"		W 01049	25	250	.13	11/32		
	1-1/8" x 3/4"		W 01050	25	250	.11	23/64		
	1-1/8" x 5/8"		W 01051	25	250	.11	13/32		
	1-1/8" x 1/2"		W 01052	25	250	.11	15/32		
	1-3/8" x 1-1/8"		W 01056	10	100	.2	9/32		
	1-3/8" x 7/8"		W 01058	10	100	.17	13/32		
	1-3/8" x 5/8"		W 01060	10	100	.17	17/32		
	1-5/8" x 1-3/8"		W 01064	10	100	.23	5/16		
	1-5/8" x 1-1/8"		W 01065	10	100	.23	15/32		
	1-5/8" x 7/8"		W 01067	10	100	.24	19/32		
	1-5/8" x 5/8"		W 01069	10	100	.22	25/32		
	2-1/8" x 1-5/8"		W 01073	-	100	.43	15/32		
	2-1/8" x 1-3/8"		W 01074	-	100	.43	35/64		
	2-1/8" x 1-1/8"		W 01075	-	100	.46	13/16		
	2-1/8" x 7/8"		W 01077	-	100	.4	29/32		
	2-1/8" x 5/8"		W 01079	-	75	.41	1-3/32		



COUPLING • REDUCING continued

COPPER FITTING

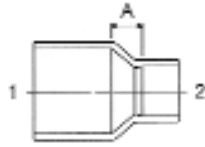
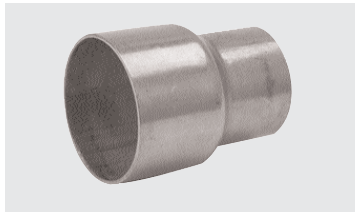

CONNECTION
C x C

MUELLER STYLE
WC-400R

ELKHART STYLE
101-R

NIBCO STYLE
9600

I	Size		Part Number	Box Qty.	Master Qty.	Approx. Net.Wt.	Dimensions		
	2	3					A	B	C
	2-5/8"	× 2-1/8"	W 01083	–	50	.65	19/32		
	2-5/8"	× 1-5/8"	W 01084	–	50	.75	7/8		
	2-5/8"	× 1-3/8"	W 01085	–	50	.7	1		
	2-5/8"	× 1-1/8"	W 01086	–	50	.71	1-3/16		
	3-1/8"	× 2-5/8"	W 01093	–	25	1.06	1/2		
	3-1/8"	× 2-1/8"	W 01094	–	25	1.1	15/16		
	3-1/8"	× 1-5/8"	W 01095	–	25	1.01	1-1/4		
	3-5/8"	× 3-1/8"	W 10101	–	25	1.22	29/64		
	4-1/8"	× 3-5/8"	W 10108	–	20	1.87	5/8		
	4-1/8"	× 3-1/8"	W 10109	–	20	.76	29/32		
	4-1/8"	× 2-5/8"	W 10110	–	15	1.88	1-7/16		
	4-1/8"	× 2-1/8"	W 10111	–	20	1.97	1-5/8		

CROSS • FORGED BRASS

COPPER FITTING

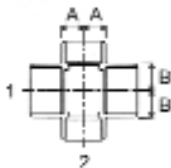

CONNECTION
C x C x C x C

MUELLER STYLE
WT-603

ELKHART STYLE
N/A

NIBCO STYLE
N/A

I	Size		Part Number	Box Qty.	Master Qty.	Approx. Net.Wt.	Dimensions		
	2	3					A	B	C
1/4"			A 01409*	25	1,000	.05	1/4	1/4	

45° ELBOW

COPPER FITTING

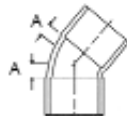

CONNECTION
C x C

MUELLER STYLE
WE-504

ELKHART STYLE
106

NIBCO STYLE
9606

I	Size		Part Number	Box Qty.	Master Qty.	Approx. Net.Wt.	Dimensions		
	2	3					A	B	C
	1/4"		W 03005	50	1,700	.01	3/16		
	3/8"		W 03012	50	1,700	.01	3/16		
	1/2"		W 03021	25	850	.03	13/64		
	5/8"		W 03026	50	500	.04	17/64		
	3/4"		W 03030	50	500	.06	5/16		
	7/8"		W 03034	25	250	.10	23/64		
	1-1/8"		W 03044	10	200	.18	15/32		
	1-3/8"		W 03050	10	100	.25	7/16		
	1-5/8"		W 03055	10	100	.36	1/2		
	2-1/8"		W 03059	10	50	.6	5/8		
	2-5/8"		W 03063	5	25	1	29/32		
	3-1/8"		W 03067	2	20	1.53	29/32		
	3-5/8"		W 03070	2	10	2.81	1-9/64		
	4-1/8"		W 03073	–	5	4.68	1-3/16		

TUBE & PIPE

METAL FITTINGS & NIPPLES

PLASTIC FITTINGS

VALVES

FILTER-DRIERS & STRAINERS



45° ELBOW • STREET

COPPER FITTING

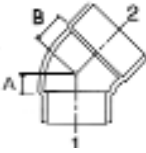

CONNECTION
FTG x C

MUELLER STYLE
WE-505

ELKHART STYLE
106-2

NIBCO STYLE
9606-2

I	Size		Part Number	Box Qty.	Master Qty.	Approx. Net.Wt.	Dimensions		
	2	3					A	B	C
	3/8		W 03312	100	3,400	.01	9/16	3/16	
	1/2		W 03321	100	1,500	.03	21/32	13/64	
	5/8		W 03326	50	500	.04	13/16	17/64	
	3/4		W 03330	50	500	.06	1	5/16	
	7/8		W 03334	25	250	.10	1-11/64	23/64	
	1-1/8		W 03344	25	250	.15	1-7/16	15/32	
	1-3/8		W 03350	10	100	.24	1-13/16	25/32	
	1-5/8		W 03355	10	100	.33	2-5/64	15/16	
	2-1/8		W 03359	5	50	.61	2-3/32	5/8	
	2-5/8		W 03363	2	20	1.05	3-2/16	29/32	
	3-1/8		W 03368	2	10	1.52	2-17/32	29/32	
	4-1/8		W 03373	-	5	3.11	4-5/32	1-15/16	

45° ELBOW

COPPER FITTING



CONNECTION
FTG x FTG

MUELLER STYLE
WE-507

ELKHART STYLE
106-2-2

NIBCO STYLE
9606-2-2

I	Size		Part Number	Box Qty.	Master Qty.	Approx. Net.Wt.	Dimensions		
	2	3					A	B	C
	1/2"		W 03621	50	1,700	.02		21/32	
	5/8"		W 03626	50	750	.04		13/16	
	7/8"		W 03634	25	250	.10		1-11/64	
	1-1/8"		W 03644	10	100	.18		1-7/16	

90° ELBOW • SHORT RADIUS

COPPER FITTING

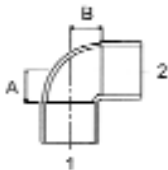

CONNECTION
C x C

MUELLER STYLE
WE-500

ELKHART STYLE
107-C

NIBCO STYLE
9607-1

I	Size		Part Number	Box Qty.	Master Qty.	Approx. Net.Wt.	Dimensions		
	2	3					A	B	C
	1/4		W 02003	50	17,00	.01	3/8	3/8	
	3/8		W 02009	50	1,700	.02	3/8	3/8	
	1/2		W 02017	50	1,000	.03	1/2	1/2	
	5/8		W 02022	100	1,000	.05	19/32	19/32	
	3/4		W 02028	50	500	.08	7/8	7/8	
	7/8		W 02034	50	500	.11	53/64	53/64	
	1		W 02040	20	200	.22	1-1/8	1-1/8	
	1-1/8		W 02047	25	250	.20	1-5/64	1-5/64	
	1-3/8		W 02084	10	100	.3	1-3/32	1-3/32	
	1-5/8		W 02085	10	100	.42	1-7/32	1-7/32	
	2-1/8		W 02086	10	50	.76	1-9/16	1-9/16	
	2-5/8		W 02087	5	25	1.19	1-13/16	1-13/16	
	3-1/8		W 02088	5	25	1.88	2-1/16	2-1/16	



90° ELBOW • SHORT RADIUS continued

COPPER FITTING

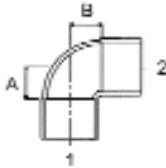

I	CONNECTION C x C			Part Number	Box Qty.	Master Qty.	Approx. Net.Wt.	Dimensions			
	MUELLER STYLE WE-500		ELKHART STYLE 107-C					NIBCO STYLE 9607-1	A	B	C
	Size	2	3								
3-5/8				W 02089	2	10	2.77	2-13/32	2-13/32		
4-1/8				W 02090	2	10	4	2-23/32	2-23/32		
6-1/8				W 02097	-	1	13.73	4-13/64	4-13/64		

REDUCING

3/8" x 1/4"				W 02011	50	750	.02	7/16	11/32	
1/2" x 3/8"				W 02019	50	750	.03	9/16	7/16	
5/8" x 1/2"				W 02023	50	500	.05	5/8	1/2	
5/8" x 3/8"				W 02025	50	500	.05	21/32	7/16	
3/4" x 5/8"				W 02029	50	500	.06	11/16	19/32	
3/4" x 1/2"				W 02030	50	500	.07	13/16	1/2	
7/8" x 3/4"				W 02035	50	500	.11	29/32	7/8	
7/8" x 5/8"				W 02036	50	500	.11	59/64	21/32	
7/8" x 1/2"				W 02037	50	500	.11	15/16	5/8	
1-1/8" x 7/8"				W 02049	25	250	.17	1	7/8	
1-1/8" x 3/4"				W 02050	25	250	.16	1	7/8	
1-1/8" x 5/8"				W 02051	25	250	.18	1-3/16	3/4	
1-1/8" x 1/2"				W 02052	25	150	.20	1-11/32	21/32	
1-3/8" x 1-1/8"				W 02056	20	200	.32	1-7/16	1-1/8	
1-5/8" x 1-3/8"				W 02077	5	100	.33	1-9/64	55/64	
2-1/8" x 1-5/8"				W 02078	5	50	.6	1-9/16	1-13/64	

90° ELBOW • LONG RADIUS

COPPER FITTING

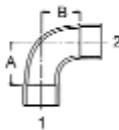

I	CONNECTION C x C			Part Number	Box Qty.	Master Qty.	Approx. Net.Wt.	Dimensions			
	MUELLER STYLE WE-500L		ELKHART STYLE 107-L					NIBCO STYLE 9607-LT	A	B	C
	Size	2	3								
3/16				W 02701	50	1,000	.01	5/16	5/16		
1/4				W 02715	50	1,700	.01	1/2	1/2		
5/16				W 02710	50	1,700	.01	9/16	9/16		
3/8				W 02716	50	1,700	.02	3/4	3/4		
1/2				W 02717	50	500	.04	3/4	3/4		
5/8				W 02722	50	500	.06	7/8	7/8		
3/4				W 02728	50	500	.09	1-1/8	1-1/8		
7/8				W 02734	25	250	.13	1-3/16	1-3/16		
1-1/8				W 02747	10	100	.27	1-1/2	1-1/2		
1-1/4				W 02054	50	50	.33	1-7/8	1-7/8		
1-3/8				W 02055	10	100	.42	1-7/8	1-7/8		
1-5/8				W 02063	5	50	.6	2-1/4	2-1/4		
2-1/8				W 02072	5	25	1.23	2-7/8	2-7/8		
2-5/8				W 02082	5	25	2.05	3-21/32	3-21/32		
3-1/8				W 02092	2	10	3.13	4-5/8	4-5/8		
3-5/8				W 02093	1	5	5.53	4-29/32	4-29/32		
4-1/8				W 02095	-	1	7.98	5-7/8	5-7/8		

TUBE & PIPE

METAL FITTINGS & NIPPLES

PLASTIC FITTINGS

VALVES

FILTER-DRIERS & STRAINERS



90° ELBOW • LONG RADIUS continued

COPPER FITTING

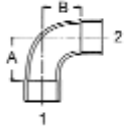

CONNECTION
C x C

MUELLER STYLE
WE-500L

ELKHART STYLE
107-L

NIBCO STYLE
9607-LT

1	Size		Part Number	Box Qty.	Master Qty.	Approx. Net.Wt.	Dimensions		
	2	3					A	B	C
REDUCING									
	3/8" x 1/4"		W 02711	50	3,000	.01	19/32	15/32	
	1/2" x 3/8"		W 02719	50	1,000	.03	41/64	39/64	
	5/8" x 1/2"		W 02723	50	500	.04	3/4	11/16	
	5/8" x 3/8"		W 02725	50	1,000	.03	11/16	5/8	
	7/8" x 3/8"		W 02735	25	250	.12	1-5/32	1-1/16	
	7/8" x 5/8"		W 02736	50	500	.09	1-7/8	1-7/8	
	1-1/8" x 7/8"		W 02749	10	200	.17	1-1/4	1-9/64	
	1-1/8" x 5/8"		W 02751	25	250	.12	1-1/8	7/8	
	1-3/8" x 1-1/8"		W 02756	10	100	.31	1-5/8	1-15/32	
	1-5/8" x 1-3/8"		W 02064	5	50	.44	1-59/64	1-7/8	
	1-5/8" x 1-1/8"		W 02065	5	50	.52	2-1/8	1-5/8	
	1-5/8" x 7/8"		W 02067	5	50	.51	2-3/64	1-3/8	
	2-1/8" x 1-5/8"		W 02073	2	20	.98	2-7/16	2-11/64	
	2-1/8" x 1-3/8"		W 02074	2	20	.94	2-1/2	2-1/8	
	2-1/8" x 1-1/8"		W 02075	2	20	.97	2-1/2	2-3/32	
	2-5/8" x 2-1/8"		W 02083	2	20	1.53	2-31/32	2-31/32	

90° ELBOW • SHORT RADIUS STREET

COPPER FITTING

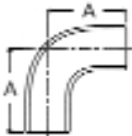

CONNECTION
FTG x C

MUELLER STYLE
WE-503

ELKHART STYLE
107-C-2

NIBCO STYLE
9607-2

1	Size		Part Number	Box Qty.	Master Qty.	Approx. Net.Wt.	Dimensions		
	2	3					A	B	C
	1/4		W 02305	50	1,700	.01	3/4	3/8	
	3/8		W 02312	50	1,700	.02	3/4	3/8	
	1/2		W 02321	50	750	.03	15/16	1/2	
	5/8		W 02326	50	500	.05	1-5/32	19/32	
	3/4		W 02330	25	250	.09	1-7/16	7/8	
	7/8		W 02334	25	250	.11	1-5/8	13/16	
	1-1/8		W 02344	25	250	.21	2-1/32	1-1/16	
	1-3/8		W 02384	25	125	.29	2-5/64	1-1/16	
	1-5/8		W 02385	10	100	.44	2-3/8	1-7/32	
	2-1/8		W 02386	10	50	.86	2-25/32	1-3/8	
	2-5/8		W 02387	5	25	1.23	3-11/32	1-13/16	
	3-1/8		W 02388	2	20	1.94	3-25/32	2-1/16	
	3-5/8		W 02389	1	10	2.78	4-3/8	2-23/64	
	4-1/8		W 02390	2	10	4.03	4-15/16	2-23/64	

90° ELBOW • LONG RADIUS STREET

COPPER FITTING

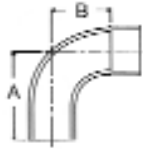

CONNECTION
FTG x C

MUELLER STYLE
WE-503L

ELKHART STYLE
107-L-2

NIBCO STYLE
9607-2-LT

I	Size		Part Number	Box Qty.	Master Qty.	Approx. Net.Wt.	Dimensions		
	2	3					A	B	C
	3/8"		W 02809	50	1,700	.02	1-1/8	3/4	
	1/2"		W 02817	50	500	.04	1-3/16	3/4	
	5/8"		W 02822	50	500	.06	1-3/8	7/8	
	3/4"		W 02828	25	250	.09	1-13/16	1-1/8	
	7/8"		W 02834	25	250	.13	2	1-3/16	
	1-1/8"		W 02847	10	100	.27	2-15/32	1-1/2	
	1-3/8"		W 02350	10	100	.42	2-29/32	1-7/8	
	1-5/8"		W 02355	5	50	.60	3-7/16	2-1/4	
	2-1/8"		W 02359	5	25	1.23	4-9/32	2-7/8	
	2-5/8"		W 02363	5	25	2.08	5-5/32	3-21/32	
	3-1/8"		W 02368	2	10	3.12	6-9/32	4-5/8	
	3-5/8"		W 02393	1	5	5.52	7-7/32	5-1/4	
	4-1/8"		W 02395	-	1	8.07	8-3/32	5-7/8	

90° ELBOW • SHORT RADIUS

COPPER FITTING

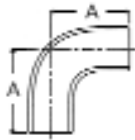

CONNECTION
FTG x FTG

MUELLER STYLE
WE-506

ELKHART STYLE
105-C

NIBCO STYLE
9607-2-2

I	Size		Part Number	Box Qty.	Master Qty.	Approx. Net.Wt.	Dimensions		
	2	3					A	B	C
	3/8"		W 02612	50	1,700	.02	3/4		
	1/2"		W 02621	50	750	.03	15/16		
	5/8"		W 02626	50	500	.05	1-5/32		
	7/8"		W 02634	25	250	.11	1-5/8		
	1-1/8"		W 02644	10	100	.22	2-1/32		
	1-3/8"		W 02684	10	100	.31	2-5/64		
	1-5/8"		W 02685	5	50	.43	2-3/8		
	2-1/8"		W 02686	1	10	.79	2-31/32		
	2-5/8"		W 02687	1	10	1.25	3-21/64		
	3-1/8"		W 02688	1	10	2.08	3-25/32		
	3-5/8"		W 02689	1	10	2.63	4-11/32		
	4-1/8"		W 02690	1	5	3.88	4-7/8		

90° ELBOW • LONG RADIUS

COPPER FITTING

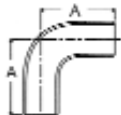

CONNECTION
FTG x FTG

MUELLER STYLE
WE-506L

ELKHART STYLE
105-L

NIBCO STYLE
607-2-2-LT

I	Size		Part Number	Box Qty.	Master Qty.	Approx. Net.Wt.	Dimensions		
	2	3					A	B	C
	1-3/8"		W 02650	5	50	.44	2-29/32		
	1-5/8"		W 02655	5	50	.63	3 -7/16		
	2-1/8"		W 02659	1	10	1.23	4-23/64		

TUBE & PIPE

METAL FITTINGS & NIPPLES

PLASTIC FITTINGS

VALVES

FILTER-DRIERS & STRAINERS



90° ELBOW • FORGED BRASS

COPPER FITTING

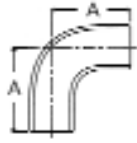

CONNECTION
C x F

I	Size		Part Number	Box Qty.	Master Qty.	Approx. Net.Wt.	Dimensions		
	2	3					A	B	C
			W 02206*	50	450	.10	1/2	3/4	
			W 02207*	50	800	.07	7/16	25/32	
			W 02214*	50	600	.10	9/16	45/64	
			W 02215*	50	600	.09	1/2	3/4	
			W 02216*	50	700	.08	1/4	29/32	
			W 02224*	-	225	.24	21/32	59/64	
			W 02225*	25	300	.11	1/2	45/64	
			W 02226*	25	350	.10	7/16	3/4	
			W 02230*	10	150	.29	21/32	1	
			W 02231*	10	240	.25	1/2	15/16	
			W 02232*	10	240	.17	37/64	25/32	
			W 02238*	10	150	.28	21/32	1-3/64	
			W 02239*	10	140	.26	21/32	1-1/32	
			W 02246*	10	150	.28	21/32	1-3/64	
			W 02247*	10	150	.23	33/64	1-3/32	
			W 02264*	10	90	.44	23/32	1-7/32	

90° ELBOW • FORGED BRASS

COPPER FITTING

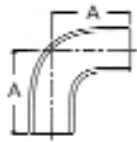

CONNECTION
C x M

I	Size		Part Number	Box Qty.	Master Qty.	Approx. Net.Wt.	Dimensions		
	2	3					A	B	C
			W 02105*	50	450	.11	1	29/64	
			W 02106*	50	700	.07	7/8	3/8	
			W 02107*	50	1,200	.04	3/4	1/8	
			W 02113*	25	350	.16	1-1/4	15/32	
			W 02114*	50	450	.10	1	29/64	
			W 02115*	50	800	.06	7/8	1/4	
			W 02116*	50	800	.06	3/4	19/64	
			W 02123*	10	140	.22	1-1/2	9/16	
			W 02124*	25	300	.13	1-1/4	5/16	
			W 02125*	25	400	.10	1	5/16	
			W 02126*	25	400	.09	1	1/4	
			W 02130*	10	160	.22	1-1/2	9/16	
			W 02131*	10	240	.17	1-1/4	17/32	
			W 02132*	10	240	.16	1-1/8	7/16	
			W 02137*	10	140	.90	1-11/16	15/32	
			W 02138*	10	210	.22	1-1/2	15/32	
			W 02146*	10	150	.31	1-1/2	9/16	
			W 02147*	15	180	.24	1-13/32	33/64	
			W 02148*	10	120	.24	1-13/64	33/64	
			W 02163*	10	90	.45	1-23/32	23/32	
			W 02164*	10	120	.44	1-17/32	23/32	

FITTING REDUCER

COPPER FITTING

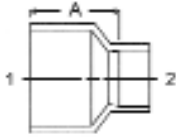
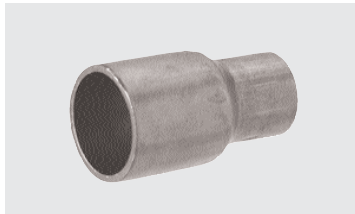

CONNECTION
FTG x C

MUELLER STYLE
WC-403

ELKHART STYLE
118

NIBCO STYLE
9600-2

I	Size		Part Number	Box Qty.	Master Qty.	Approx. Net.Wt.	Dimensions		
	2	3					A	B	C
	1/4"	1/8"	W 01302	50	2,000	.01	17/32		
	3/8"	1/4"	W 01306	50	1,700	.01	3/8		
	1/2"	3/8"	W 01312	50	1,700	.02	5/8		
	1/2"	1/4"	W 01314	50	1,700	.01	19/32		
	5/8"	1/2"	W 01315	50	750	.03	3/4		
	5/8"	3/8"	W 01317	50	1,700	.02	25/32		
	3/4"	5/8"	W 01320	100	1,000	.04	7/8		
	3/4"	1/2"	W 01321	100	900	.04	29/32		
	3/4"	3/8"	W 01322	100	900	.04	7/8		
	7/8"	3/4"	W 01325	50	500	.06	31/32		
	7/8"	5/8"	W 01326	50	500	.06	61/64		
	7/8"	1/2"	W 01327	50	500	.06	1-1/8		
	1-1/8"	7/8"	W 01337	25	250	.11	1-7/64		
	1-1/8"	3/4"	W 01338	25	250	.01	1-1/4		
	1-1/8"	5/8"	W 01339	25	250	.10	1-11/32		
	1-1/8"	1/2"	W 01340	20	200	.01	1-3/8		
	1-3/8"	1-1/8"	W 01343	10	100	.17	1-7/32		
	1-3/8"	7/8"	W 01345	10	100	.17	1-11/32		
	1-3/8"	5/8"	W 01347	10	100	.16	1-1/2"		
	1-5/8"	1-3/8"	W 01350	10	100	.23	1-13/32		
	1-5/8"	1-1/8"	W 01351	10	100	.24	1-17/32		
	1-5/8"	7/8"	W 01353	10	100	.23	1-11/16		
	1-5/8"	5/8"	W 01355	10	100	.22	1-3/4		
	2-1/8"	1-5/8"	W 01358	-	100	.44	1-27/32		
	2-1/8"	1-3/8"	W 01359	-	100	.43	2-1/32		
	2-1/8"	1-1/8"	W 01360	-	100	.45	2-1/8		
	2-1/8"	7/8"	W 01362	-	100	.43	2-3/16		
	2-1/8"	5/8"	W 01364	-	100	.42	2-5/8		
	2-5/8"	2-1/8"	W 01367	-	50	.62	2-1/32		
	2-5/8"	1-5/8"	W 01368	-	50	.57	2-7/32		
	2-5/8"	1-3/8"	W 01369	-	50	.62	2-15/32		
	2-5/8"	1-1/8"	W 01370	-	50	.63	2-7/8		
	3-1/8"	2-5/8"	W 01376	-	25	1	2-1/32		
	3-1/8"	2-1/8"	W 01377	-	25	.89	2-1/2		
	3-1/8"	1-5/8"	W 01378	-	50	.92	2-21/32		
	3-1/8"	1-3/8"	W 01379	-	50	1.01	3		
	3-5/8"	3-1/8"	W 01381	-	20	1.28	2-11/32		
	3-5/8"	2-5/8"	W 01382	-	20	1.37	1-39/64		
	3-5/8"	2-1/8"	W 01383	-	20	1.47	3-3/32		
	4-1/8"	3-5/8"	W 01386	-	20	1.74	2-1/2		
	4-1/8"	3-1/8"	W 01387	-	15	1.77	2-31/32		
	4-1/8"	2-5/8"	W 01388	-	15	1.83	3-35/64		
	4-1/8"	2-1/8"	W 01389	-	15	1.86	3-21/32		

TUBE & PIPE

METAL FITTINGS & NIPPLES

PLASTIC FITTINGS

VALVES

FILTER-DRIERS & STRAINERS



P-TRAPS • SUCTION LINE

COPPER FITTING

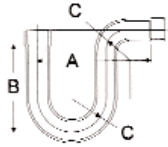

CONNECTION
C x C

MUELLER STYLE
WE-554P

ELKHART STYLE
123

NIBCO STYLE
9698

I	Size		Part Number	Box Qty.	Master Qty.	Approx. Net.Wt.	Dimensions		
	2	3					A	B	C
	5/8"		W 60999	10	50	.38	6.00	5.55	1.50
	3/4"		W 61008	10	50	.51	6.00	6.13	1.50
	7/8"		W 61000	5	25	.63	6.00	6.13	1.50
	1-1/8"		W 61001	3	15	.87	5.73	6.13	1.50
	1-3/8"		W 61002	4	20	1.16	6.56	5.28	1.88
	1-5/8"		W 61003	4	1	2.28	8.66	7.90	2.50
	2-1/8"		W 61009	1	3	3.87	9.90	8.66	3.00

PLUG • FITTING

COPPER FITTING

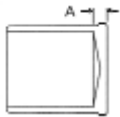

CONNECTION
FTG

MUELLER STYLE
WC-416

ELKHART STYLE
116

NIBCO STYLE
9616

I	Size		Part Number	Box Qty.	Master Qty.	Approx. Net.Wt.	Dimensions		
	2	3					A	B	C
	1/4"		A 01402	50	500	.01	1/8		
	3/8"		A 01422	100	4,000	.01	1/8		
	1/2"		A 01392	50	2,000	.02	1/8		
	5/8"		A 01504	50	1,200	.03	1/8		
	3/4"		A 02273	10	560	.05	1/8		
	7/8"		A 01529	50	600	.07	1/8		
	1-1/8"		A 01556	25	375	.12	1/8		
	1-3/8"		A 01590	180	180	.20	1/8		
	1-5/8"		A 01628	10	120	.28	1/8		

RETURN BEND

COPPER FITTING

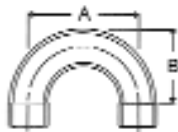

CONNECTION
C x C

MUELLER STYLE
WE-512

ELKHART STYLE
138

NIBCO STYLE
9638

I	Size		Part Number	Box Qty.	Master Qty.	Approx. Net.Wt.	Dimensions		
	2	3					A	B	C
	3/8"	4-1/2"	W 06025	25	150	.01	4-1/2	2-7/16	
	3/8"	1-1/2"	W 06020	25	850	.02	1-1/2	15/16	
	1/2"	6"	W 06048	-	100	.21	6	3-1/4	
	1/2"	4"	W 06045	-	200	.14	4	2-5/16	
	1/2"	3"	W 06041	25	225	.11	3	1-3/4	
	1/2"	2"	W 06036	50	300	.06	2	1-1/4	
	1/2"	1-29/32"	W 06035	50	300	.08	1-29/32	1-13/64	
	1/2"	1-1/2"	W 06032	50	500	.06	1-1/2	1	
	5/8"	6"	W 06069	5	30	.30	6	3-5/16	
	5/8"	3-3/8"	W 06062	10	100	.18	3-3/8	2	
	5/8"	3"	W 06060	25	150	.16	3	1-13/16	
	5/8"	2-1/2"	W 06058	25	250	.14	2-1/2	1-9/16	
	5/8"	2-1/4"	W 06056	25	250	.13	2-1/4	1-1/2	
	5/8"	1-7/8"	W 06053	25	250	.11	1-7/8	1-1/4	
	5/8"	1-9/16"	W 06051	25	250	.10	1-9/16	1-3/32	



RETURN BEND continued

COPPER FITTING

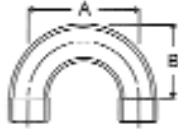

CONNECTION
C x C

MUELLER STYLE
WE-512

ELKHART STYLE
138

NIBCO STYLE
9638

I	Size		Part Number	Box Qty.	Master Qty.	Approx. Net.Wt.	Dimensions		
	2	3					A	B	C
	3/4"	× 4"	W 06084	–	120	.25	4	1-7/8	
	3/4"	× 3-3/8"	W 06081	10	90	.24	3-3/8	2-1/16	
	3/4"	× 2-1/2"	W 06077	10	100	.17	2-1/2	1-5/8	
	3/4"	× 2-1/8"	W 06074	10	100	.15	2-1/8	1-7/16	
	3/4"	× 2"	W 06073	10	100	.16	2	1-3/8	
	7/8"	× 12"	W 06099	15	15	.88	12	6-7/16	
	7/8"	× 3-3/8"	W 06095	10	100	.29	3-3/8	2-1/8	
	7/8"	× 2-1/2"	W 06092	10	100	.23	2-1/2	1-11/16	
	1-1/8"	× 3-1/4"	W 60111	5	50	.49	3-1/4	2-3/16	
	7/8"	× 3"	W 60110	5	50	.47	3	2-1/16	
	1-3/8"	× 3-3/4"	W 60121	5	50	.65	3-3/4	2-9/16	
	1-5/8"	× 4-1/2"	W 60131	–	25	1	4-1/2	3-1/6	
	2-1/8"	× 5-1/2"	W 60140	1	15	1.92	5-1/2	3-13/16	

TEE

COPPER FITTING

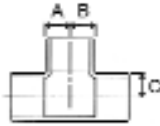

CONNECTION
C x C x C

MUELLER STYLE
WT-600

ELKHART STYLE
111

NIBCO STYLE
9611

I	Size		Part Number	Box Qty.	Master Qty.	Approx. Net.Wt.	Dimensions			
	2	3					A	B	C	
	3/16		W 40302	50	2,000	.01	7/64	7/64	25/32	
	1/4		W 40306	100	2,400	.01	5/32	5/32	5/32	
	5/16		W 40313	50	1,700	.01	13/64	13/64	3/16	
	3/8		W 04000	50	1,700	.02	13/64	13/64	3/16	
	1/2		W 04001	50	500	.04	17/64	17/64	1/4	
	5/8		W 04006	50	500	.06	21/64	21/64	21/64	
	3/4		W 04017	25	250	.12	13/32	13/32	25/64	
	7/8		W 04031	25	250	.17	15/32	15/32	29/64	
	1-1/8		W 04048	10	100	.31	37/64	37/64	9/16	
	1-3/8		W 04068	5	50	.42	23/32	23/32	45/64	
	1-5/8		W 04084	5	50	.6	53/64	53/64	53/64	
	2-1/8		W 40102	5	25	1.14	1-3/32	1-3/32	1-3/32	
	2-5/8		W 40123	2	20	1.72	1-5/16	1-5/16	1-3/8	
	3-1/8		W 40152	2	10	2.77	1-19/32	1-19/32	1-5/8	
	3-5/8		W 40190	1	5	5.66	1-15/16	1-15/16	1-55/64	
	4-1/8		W 40200	1	5	5.99	2-1/8	2-1/8	2-1/8	
	5-1/8		W 40400	–	1	12.38	2-45/64	2-45/64	2-47/64	
	6-1/8		W 40500	–	1	20.85	3-1/16	3-1/16	3-1/4	
REDUCING										
	1/4"	× 1/4"	× 3/8"	W 40368	50	750	.03	33/64	33/64	3/16
	1/4"	× 1/4"	× 3/16"	W 40308	50	2,000	.01	15/32	15/32	11/32
	5/16"	× 5/16"	× 3/8"	W 40334	50	750	.03	15/32	15/32	7/32
	3/8"	× 3/8"	× 5/8"	W 04016	50	500	.08	13/32	13/32	15/64
	3/8"	× 3/8"	× 1/2"	W 04005	50	500	.04	1/4	1/4	15/64
	3/8"	× 3/8"	× 1/4"	W 40324	50	1,700	.02	5/32	5/32	7/32
	3/8"	× 1/4"	× 3/8"	W 40330	50	500	.02	13/64	33/64	3/16
	3/8"	× 1/4"	× 1/4"	W 40332	50	1,700	.02	5/32	3/8	7/32

TUBE & PIPE

METAL FITTINGS & NIPPLES

PLASTIC FITTINGS

VALVES

FILTER-DRIERS & STRAINERS



TEE continued

COPPER FITTING

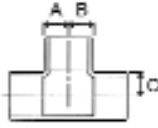
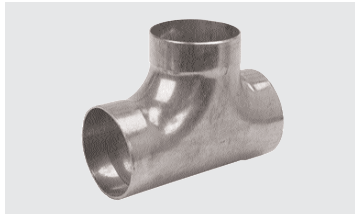

CONNECTION
C x C x C

MUELLER STYLE
WT-600

ELKHART STYLE
111

NIBCO STYLE
9611

I	Size		Part Number	Box Qty.	Master Qty.	Approx. Net.Wt.	Dimensions		
	2	3					A	B	C
REDUCING									
	1/2" x 1/2"	5/8"	W 04015	50	500	.09	21/32	21/32	21/64
	1/2" x 1/2"	3/8"	W 04002	50	500	.04	7/32	7/32	9/32
	1/2" x 1/2"	1/4"	W 40350	50	500	.04	7/32	7/32	19/32
	1/2" x 3/8"	1/2"	W 04003	50	500	.05	17/64	9/16	1/4
	1/2" x 3/8"	3/8"	W 04004	50	500	.04	7/32	1/2	9/32
	1/2" x 3/8"	1/4"	W 40358	50	750	.04	7/32	33/64	19/32
	1/2" x 1/4"	1/2"	W 40363	50	750	.05	17/64	39/64	1/4
	1/2" x 1/4"	3/8"	W 40364	50	750	.04	7/32	21/32	19/64
	1/2" x 1/4"	1/4"	W 40366	50	450	.05	7/32	21/32	23/32
	5/8" x 5/8"	1-1/8"	W 04067	10	100	.35	1-5/16	1-5/16	5/8
	5/8" x 5/8"	7/8"	W 04047	25	250	.11	15/32	15/32	21/64
	5/8" x 5/8"	3/4"	W 04029	25	250	.10	29/64	29/64	13/32
	5/8" x 5/8"	1/2"	W 04007	50	500	.08	17/64	17/64	25/64
	5/8" x 5/8"	3/8"	W 04008	50	500	.06	17/64	17/64	11/16
	5/8" x 5/8"	1/4"	W 04014	50	500	.08	17/64	17/64	11/16
	5/8" x 1/2"	5/8"	W 04009	50	500	.09	21/64	5/8	21/64
	5/8" x 1/2"	1/2"	W 04010	50	500	.08	17/64	9/16	25/64
	5/8" x 1/2"	3/8"	W 04011	50	500	.08	17/64	39/64	11/16
	5/8" x 3/8"	5/8"	W 04012	50	500	.09	21/64	11/16	21/64
	5/8" x 3/8"	1/2"	W 40367	50	500	.08	17/64	39/64	25/64
	5/8" x 3/8"	3/8"	W 04013	50	500	.09	17/64	39/64	11/16
	3/4" x 3/4"	7/8"	W 04046	25	250	.15	33/64	33/64	31/64
	3/4" x 3/4"	5/8"	W 04018	25	250	.1	21/64	21/64	7/16
	3/4" x 3/4"	1/2"	W 04019	25	250	.10	21/64	21/64	53/64
	3/4" x 3/4"	3/8"	W 04020	25	250	.10	21/64	21/64	13/16
	3/4" x 5/8"	3/4"	W 04021	25	225	.13	13/32	3/4	25/64
	3/4" x 5/8"	5/8"	W 04022	25	250	.11	19/32	1-1/64	29/64
	3/4" x 5/8"	1/2"	W 04023	25	225	.11	21/64	49/64	53/64
	3/4" x 1/2"	3/4"	W 04025	25	250	.15	13/32	15/16	25/64
	3/4" x 1/2"	5/8"	W 04026	25	225	.14	21/64	57/64	7/16
	3/4" x 1/2"	1/2"	W 04027	25	250	.11	21/64	57/64	53/64
	7/8" x 7/8"	1-1/8"	W 04065	10	100	.22	37/64	37/64	35/64
	7/8" x 7/8"	3/4"	W 04032	25	250	.17	15/32	15/32	27/32
	7/8" x 7/8"	5/8"	W 04033	25	250	.14	21/64	21/64	35/64
	7/8" x 7/8"	1/2"	W 04034	25	250	.11	21/64	21/64	55/64
	7/8" x 7/8"	3/8"	W 04035	25	250	.11	21/64	21/64	15/16
	7/8" x 3/4"	7/8"	W 04036	25	250	.19	15/32	23/32	29/64
	7/8" x 3/4"	3/4"	W 04037	25	250	.17	15/32	23/32	27/32
	7/8" x 5/8"	7/8"	W 04041	25	250	.18	15/32	23/32	29/64
	7/8" x 5/8"	3/4"	W 04042	25	150	.17	15/32	47/64	27/32
	7/8" x 5/8"	5/8"	W 04043	25	250	.15	21/64	23/32	35/64
	7/8" x 5/8"	1/2"	W 04044	25	250	.12	21/64	5/8	55/64
	7/8" x 5/8"	3/8"	W 04045	25	225	.15	21/64	11/16	15/16
	7/8" x 1/2"	7/8"	W 40230	25	250	.19	15/32	31/32	29/64
	7/8" x 1/2"	5/8"	W 40231	25	250	.17	21/64	15/16	17/32
	7/8" x 1/2"	1/2"	W 40232	25	250	.12	21/64	51/64	51/64
	1-1/8" x 1-1/8"	1-5/8"	W 40101	5	50	.47	1-21/32	1-21/32	53/64
	1-1/8" x 1-1/8"	1-3/8"	W 04082	5	50	.31	11/16	11/16	37/64
	1-1/8" x 1-1/8"	7/8"	W 04049	10	100	.32	15/32	15/32	49/64
	1-1/8" x 1-1/8"	3/4"	W 04050	10	100	.27	15/32	15/32	1-1/64
	1-1/8" x 1-1/8"	5/8"	W 04051	10	100	.20	23/64	23/64	21/32
	1-1/8" x 1-1/8"	1/2"	W 04052	10	100	.19	23/64	23/64	1-3/32
	1-1/8" x 7/8"	1-1/8"	W 04055	10	100	.3	19/32	1-3/64	5/8
	1-1/8" x 7/8"	7/8"	W 04056	10	100	.25	15/32	49/64	49/64

TUBE & PIPE

METAL FITTINGS & NIPPLES

PLASTIC FITTINGS

VALVES

FILTER-DRYERS & STRAINERS



TEE continued

COPPER FITTING

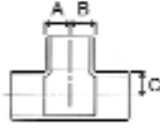

CONNECTION
C x C x C

MUELLER STYLE
WT-600

ELKHART STYLE
111

NIBCO STYLE
9611

I	Size		Part Number	Box Qty.	Master Qty.	Approx. Net.Wt.	Dimensions		
	2	3					A	B	C
REDUCING									
1-1/8" x 7/8" x 3/4"	W 04057	10	90	.43	15/32	49/64	1-1/64		
1-1/8" x 7/8" x 5/8"	W 04058	10	100	.23	23/64	41/64	21/32		
1-1/8" x 7/8" x 1/2"	W 04059	10	100	.21	23/64	41/64	1-3/32		
1-1/8" x 3/4" x 1-1/8"	W 40233	10	100	.33	37/64	1-7/32	9/16		
1-1/8" x 3/4" x 7/8"	W 40234	10	90	.3	15/32	1-1/32	49/64		
1-1/8" x 3/4" x 3/4"	W 40235	10	100	.31	15/32	1-1/32	1-1/16		
1-1/8" x 3/4" x 5/8"	W 40236	10	90	.35	23/64	31/32	21/32		
1-1/8" x 5/8" x 1-1/8"	W 04061	10	100	.31	37/64	1-7/32	9/16		
1-1/8" x 5/8" x 7/8"	W 04062	10	100	.32	15/32	1-5/32	49/64		
1-1/8" x 5/8" x 5/8"	W 04063	10	100	.36	23/64	31/32	21/32		
1-3/8" x 1-3/8" x 2-1/8"	W 40122	2	20	1.68	2-1/16	2-1/16	1-3/32		
1-3/8" x 1-3/8" x 1-5/2"	W 40100	5	50	.72	27/32	27/32	23/32		
1-3/8" x 1-3/8" x 1-1/8"	W 04069	5	50	.49	37/64	37/64	53/64		
1-3/8" x 1-3/8" x 7/8"	W 04070	5	50	.33	29/64	29/64	13/16		
1-3/8" x 1-3/8" x 5/8"	W 04071	5	50	.28	21/64	21/64	13/16		
1-3/8" x 1-3/8" x 1/2"	W 04072	5	50	.29	21/64	21/64	1-3/16		
1-3/8" x 1-1/8" x 1-3/8"	W 04073	5	50	.54	23/32	1-7/32	49/64		
1-3/8" x 1-1/8" x 1-1/8"	W 04074	5	50	.53	19/32	1-1/8	53/64		
1-3/8" x 1-1/8" x 7/8"	W 04075	5	50	.38	29/64	59/64	13/16		
1-3/8" x 1-1/8" x 5/8"	W 04076	5	50	.57	21/64	51/64	13/16		
1-3/8" x 7/8" x 1-3/8"	W 04078	5	50	.56	23/32	1-9/16	25/32		
1-3/8" x 7/8" x 1-1/8"	W 04079	5	50	.52	19/32	1-27/64	1-3/16		
1-3/8" x 7/8" x 7/8"	W 04080	5	50	.39	29/64	1-7/64	1-3/16		
1-3/8" x 7/8" x 5/8"	W 04081	5	50	.32	23/64	59/64	49/64		
1-3/8" x 5/8" x 1-3/8"	W 04083	5	50	.57	23/32	1-5/8	11/16		
1-5/8" x 1-5/8" x 2-1/8"	W 40121	2	20	1.22	1-1/16	1-1/16	57/64		
1-5/8" x 1-5/8" x 1-3/8"	W 04085	5	50	.68	45/64	45/64	15/16		
1-5/8" x 1-5/8" x 1-1/8"	W 04086	5	50	.48	45/64	45/64	1-19/32		
1-5/8" x 1-5/8" x 7/8"	W 04087	5	50	.43	45/64	45/64	1-53/64		
1-5/8" x 1-5/8" x 5/8"	W 04088	5	50	.42	45/64	45/64	1-57/64		
1-5/8" x 1-5/8" x 1/2"	W 04089	5	50	.41	45/64	45/64	2		
1-5/8" x 1-3/8" x 1-5/8"	W 04090	5	50	.68	27/32	1-3/16	53/64		
1-5/8" x 1-3/8" x 1-3/8"	W 04091	5	50	.69	45/64	1-3/16	15/16		
1-5/8" x 1-3/8" x 1-1/8"	W 04092	5	50	.57	45/64	1-3/16	1-15/32		
1-5/8" x 1-3/8" x 7/8"	W 04093	5	50	.57	45/64	1-21/64	1-5/8		
1-5/8" x 1-3/8" x 5/8"	W 04094	5	50	.45	45/64	1-21/64	1-49/64		
1-5/8" x 1-1/8" x 1-5/8"	W 04095	5	50	.68	53/64	1-23/32	53/64		
1-5/8" x 1-1/8" x 1-3/8"	W 04096	5	50	.65	23/32	1-29/64	15/16		
1-5/8" x 1-1/8" x 1-1/8"	W 04097	5	50	.61	23/32	1-29/64	1-19/32		
1-5/8" x 1-1/8" x 7/8"	W 04098	5	50	.56	23/32	1-29/64	1-53/64		
1-5/8" x 1-1/8" x 5/8"	W 40237	5	30	.45	23/32	1-11/16	1-61/64		
1-5/8" x 7/8" x 1-5/8"	W 04099	5	50	.67	27/32	2-1/8	53/64		
1-5/8" x 7/8" x 1-3/8"	W 40239	5	50	.75	23/32	1-11/16	15/16		
1-5/8" x 7/8" x 1-1/8"	W 40240	5	50	.52	23/32	1-11/16	1-19/32		
1-5/8" x 7/8" x 7/8"	W 40238	5	50	.55	23/32	1-11/16	1-53/64		
1-5/8" x 7/8" x 5/8"	W 40243	5	50	.47	23/32	1-29/64	1-61/64		
1-5/8" x 5/8" x 1-5/8"	W 40244	5	50	.66	27/32	2-1/4	53/64		
2-1/8" x 2-1/8" x 3-1/8"	W 40153	1	10	2.55	1-13/16	1-13/16	1-3/32		
2-1/8" x 2-1/8" x 2-5/8"	W 40144	1	10	1.46	1-11/32	1-11/32	1-3/32		
2-1/8" x 2-1/8" x 1-5/8"	W 40103	5	50	1.19	27/32	27/32	1-13/64		
2-1/8" x 2-1/8" x 1-3/8"	W 40104	5	50	.85	27/32	27/32	1-27/32		
2-1/8" x 2-1/8" x 1-1/8"	W 40105	5	50	.88	37/64	37/64	1-9/32		
2-1/8" x 2-1/8" x 7/8"	W 40106	5	50	.83	37/64	37/64	1-11/16		
2-1/8" x 2-1/8" x 5/8"	W 40107	5	50	.67	37/64	37/64	1-15/16		

TUBE & PIPE

METAL FITTINGS & NIPPLES

PLASTIC FITTINGS

VALVES

FILTER-DRIERS & STRAINERS



TEE continued

COPPER FITTING

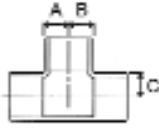

CONNECTION
C x C x C

MUELLER STYLE
WT-600

ELKHART STYLE
111

NIBCO STYLE
9611

I	Size		Part Number	Box Qty.	Master Qty.	Approx. Net.Wt.	Dimensions		
	2	3					A	B	C
REDUCING									
	1-1/8" x 7/8" x 1/2"		W 40108	2	20	.68	37/64	37/64	2-1/64
	1-1/8" x 1-5/8" x 2-1/8"		W 40109	2	20	1.60	1-3/32	1-63/64	1-3/32
	1-1/8" x 1-5/8" x 1-5/8"		W 40110	2	20	1.15	27/32	1-23/32	1-7/32
	1-1/8" x 1-5/8" x 1-3/8"		W 40111	2	20	.86	27/32	1-23/32	1-27/32
	1-1/8" x 1-5/8" x 1-1/8"		W 40112	2	20	1.06	37/64	1-29/64	1-19/64
	1-1/8" x 1-5/8" x 7/8"		W 40113	2	20	.75	37/64	1-29/64	1-11/16
	1-1/8" x 1-5/8" x 5/8"		W 40114	5	50	.77	37/64	1-9/16	1-15/16
	1-1/8" x 1-3/8" x 2-1/8"		W 40115	2	20	1.3	1-7/64	2-3/64	1-7/64
	1-1/8" x 1-3/8" x 1-5/8"		W 40116	2	20	1.14	27/32	1-27/32	1-7/32
	1-1/8" x 1-3/8" x 1-3/8"		W 40117	2	20	1.09	27/32	1-27/32	1-27/32
	1-1/8" x 1-3/8" x 1-1/8"		W 40118	2	20	.95	19/32	1-37/64	1-5/16
	1-1/8" x 1-3/8" x 7/8"		W 40119	5	50	.76	37/64	1-19/32	1-11/16
	1-1/8" x 1-3/8" x 5/8"		W 40120	5	20	.78	37/64	1-19/32	1-15/16
	1-1/8" x 1-1/8" x 2-1/8"		W 40245	5	25	1.64	19/32	2-61/64	1-9/32
	1-1/8" x 1-1/8" x 1-1/8"		W 40247	5	50	1.06	1-3/32	2-17/32	1-1/8
	1-1/8" x 7/8" x 2-1/8"		W 40248	5	25	1.71	1-3/32	2-11/16	1-1/8
	1-1/8" x 5/8" x 2-1/8"		W 40249	5	25	1.66	1-3/32	2-23/32	1-1/8
	2-5/8" x 2-5/8" x 2-1/8"		W 40124	2	20	1.59	1-3/32	1-3/32	1-17/32
	2-5/8" x 2-5/8" x 1-5/8"		W 40125	2	20	1.49	1-3/32	1-3/32	2-5/16
	2-5/8" x 2-5/8" x 1-3/8"		W 40126	2	20	1.87	1-3/32	1-3/32	2-1/2
	2-5/8" x 2-5/8" x 1-1/8"		W 40127	2	20	1.83	1-3/32	1-3/32	2-25/32
	2-5/8" x 2-5/8" x 7/8"		W 40128	1	10	1.83	1-3/32	1-3/32	2-55/64
	2-5/8" x 2-5/8" x 5/8"		W 40129	1	10	2.05	1-3/32	1-3/32	3
	2-5/8" x 2-1/8" x 2-5/8"		W 40130	4	20	2.3	1-5/16	2-7/16	1-3/8
	2-5/8" x 2-1/8" x 2-1/8"		W 40131	2	20	1.84	1-5/64	2-11/64	1-1/2
	2-5/8" x 2-1/8" x 1-5/8"		W 40132	4	20	2.09	1-5/64	2-11/64	2-7/16
	2-5/8" x 2-1/8" x 1-3/8"		W 40133	4	20	2.12	1-5/64	2-11/64	2-5/8
	2-5/8" x 2-1/8" x 1-1/8"		W 40134	4	20	2.1	1-5/64	2-11/64	2-51/64
	2-5/8" x 2-1/8" x 7/8"		W 40135	4	20	2.06	1-5/64	2-11/64	3-1/32
	2-5/8" x 2-1/8" x 5/8"		W 40136	4	20	2.2	1-5/64	2-11/64	3-3/16
	2-5/8" x 1-5/8" x 2-5/8"		W 40137	4	20	2.32	1-5/16	2-49/64	1-3/8
	2-5/8" x 1-5/8" x 2-1/8"		W 40138	4	20	1.84	1-3/32	2-27/64	1-1/2
	2-5/8" x 1-5/8" x 1-5/8"		W 40139	4	20	2.11	1-3/32	2-27/64	2-7/16
	2-5/8" x 1-5/8" x 1-3/8"		W 40140	4	20	2.17	1-3/32	2-27/64	2-9/16
	2-5/8" x 1-5/8" x 1-1/8"		W 40141	4	20	1.83	1-3/32	2-27/64	2-51/64
	2-5/8" x 1-5/8" x 7/8"		W 40142	4	20	2.36	1-3/32	2-27/64	2-29/32
	2-5/8" x 1-5/8" x 5/8"		W 40143	4	20	2.36	1-3/32	2-27/64	3-1/64
	2-5/8" x 1-3/8" x 2-5/8"		W 40220	4	20	2.35	1-5/16	2-7/8	1-3/8
	2-5/8" x 1-3/8" x 2-1/8"		W 40250	4	20	1.82	1-3/32	2-35/64	1-1/2
	2-5/8" x 1-3/8" x 1-5/8"		W 40251	4	20	2.47	1-3/32	2-35/64	2-7/16
	2-5/8" x 1-3/8" x 1-3/8"		W 40252	4	20	1.96	1-3/32	2-35/64	2-5/8
	2-5/8" x 1-3/8" x 1-1/8"		W 40253	4	20	2.47	1-3/32	2-35/64	2-3/4
	2-5/8" x 1-3/8" x 7/8"		W 40254	4	20	2.18	1-3/32	2-35/64	2-27/32
	2-5/8" x 1-3/8" x 5/8"		W 40255	4	20	2.47	1-3/32	2-35/64	2-31/32
	2-5/8" x 1-1/8" x 2-5/8"		W 40221	4	20	2.39	1-5/16	3	1-29/64
	2-5/8" x 1-1/8" x 2-1/8"		W 40256	4	20	1.97	1-5/64	2-23/32	1-1/2
	2-5/8" x 1-1/8" x 1-5/8"		W 40257	4	20	2.15	1-3/32	2-23/32	2-7/16
	2-5/8" x 1-1/8" x 1-3/8"		W 40258	4	20	2.04	1-3/32	2-11/16	2-1/2
	2-5/8" x 1-1/8" x 1-1/8"		W 40259	4	20	2.27	1-5/64	2-23/32	2-3/4
	2-5/8" x 7/8" x 2-5/8"		W 40222	4	20	2.41	1-5/16	3-5/16	1-3/8
	3-1/8" x 3-1/8" x 2-5/8"		W 40151	2	10	2.45	1-19/32	1-19/32	2-31/32
	3-1/8" x 3-1/8" x 2-1/8"		W 40150	2	20	2.3	1-5/64	1-5/64	1-25/32
	3-1/8" x 3-1/8" x 1-5/8"		W 40149	2	10	2.18	1-5/64	1-5/64	2-3/4
	3-1/8" x 3-1/8" x 1-3/8"		W 40148	2	10	2.38	1-5/64	1-5/64	3

TUBE & PIPE

METAL FITTINGS & NIPLLES

PLASTIC FITTINGS

VALVES

FILTER-DRYERS & STRAINERS



TEE continued

COPPER FITTING

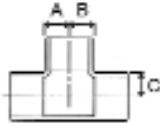
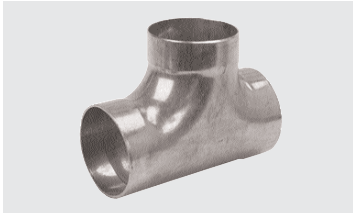

CONNECTION
C x C x C

MUELLER STYLE
WT-600

ELKHART STYLE
111

NIBCO STYLE
9611

I	Size		Part Number	Box Qty.	Master Qty.	Approx. Net.Wt.	Dimensions		
	2	3					A	B	C
REDUCING									
	3-1/8" x 3-1/8"	x 1-1/8"	W 40147	2	20	1.96	23/32	23/32	1-55/64
	3-1/8" x 3-1/8"	x 7/8"	W 40146	2	20	1.49	23/32	23/32	2-11/32
	3-1/8" x 3-1/8"	x 5/8"	W 40145	2	20	1.38	23/32	23/32	2-17/32
	3-1/8" x 2-5/8"	x 3-1/8"	W 40159	2	10	2.96	1-19/32	2-3/4	1-5/8
	3-1/8" x 2-5/8"	x 2-5/8"	W 40158	2	10	4.52	1-19/32	2-13/16	2-27/32
	3-1/8" x 2-5/8"	x 2-1/8"	W 40157	2	10	2.68	1-5/64	2-5/32	1-25/32
	3-1/8" x 2-5/8"	x 1-5/8"	W 40156	2	10	2.63	1-5/64	2-5/32	2-11/16
	3-1/8" x 2-5/8"	x 1-3/8"	W 40155	2	10	2.62	1-5/64	2-5/32	2-51/64
	3-1/8" x 2-5/8"	x 1-1/8"	W 40154	2	20	2.02	23/32	1-11/16	2
	3-1/8" x 2-1/8"	x 3-1/8"	W 40167	2	10	3.07	1-19/32	3-1/16	1-41/64
	3-1/8" x 2-5/8"	x 2-5/8"	W 40165	2	10	4.64	1-19/32	3-3/16	2-27/32
	3-1/8" x 2-5/8"	x 2-1/8"	W 40164	2	10	2.75	1-5/64	2-17/32	1-25/32
	3-1/8" x 2-5/8"	x 1-5/8"	W 40163	2	10	2.57	1-5/64	2-19/32	2-3/4
	3-1/8" x 2-5/8"	x 1-3/8"	W 40162	2	10	2.61	1-5/64	2-17/64	2-7/8
	3-1/8" x 2-5/8"	x 1-1/8"	W 40161	2	20	2.04	23/32	2-1/8	2
	3-1/8" x 1-5/8"	x 3-1/8"	W 40174	2	10	2.97	1-21/32	3-7/16	1-5/8
	3-1/8" x 1-3/8"	x 3-1/8"	W 40181	2	10	3.14	1-19/32	3-7/16	1-5/8
	3-1/8" x 1-1/8"	x 3-1/8"	W 40178	2	10	3.02	1-19/32	3-1/2	1-41/64
	3-1/8" x 7/8"	x 3-1/8"	"W 40179	2	10	3.03	1-19/32	3-21/32	1-5/8
	4-1/8" x 4-1/8"	x 3-1/8"	W 40198	1	5	4.94	1-19/32	1-19/32	2-41/64
	4-1/8" x 4-1/8"	x 2-5/8"	W 40197	1	5	5.16	1-19/32	1-19/32	3-13/64
	4-1/8" x 4-1/8"	x 2-1/8"	"W 40196	1	10	4.52	1-1/16	1-1/16	2-23/64
	4-1/8" x 4-1/8"	x 1-5/8"	W 40195	1	10	4.47	1-1/16	1-1/16	3-7/32
	4-1/8" x 4-1/8"	x 1-3/8"	W 40194	1	10	4.55	1-1/16	1-1/16	3-5/8
	4-1/8" x 4-1/8"	x 1-1/8"	"W 40193	1	10	3.05	37/64	37/64	2-37/64
	4-1/8" x 4-1/8"	x 7/8"	W 40192	1	10	2.89	9/16	9/16	3-1/16
	4-1/8" x 4-1/8"	x 5/8"	W 40191	1	10	2.89	9/16	9/16	2-63/64
	4-1/8" x 3-1/8"	x 4-1/8"	W 40208	1	5	8.66	2-1/8	3-3/4	2-13/64
	4-1/8" x 3-1/8"	x 3-1/8"	W 40206	1	5	5.12	1-19/32	3-1/8	2-41/64
	4-1/8" x 3-1/8"	x 2-5/8"	W 40205	1	5	5.61	1-19/32	3-1/8	2-13/64
	4-1/8" x 3-1/8"	x 2-1/8"	"W 40204	1	5	4.76	1-1/16	2-5/8	2-15/32
	4-1/8" x 2-5/8"	x 4-1/8"	W 40212	1	5	7.79	2-1/8	3-15/16	2-13/64
	4-1/8" x 2-1/8"	x 4-1/8"	W 40216	1	5	8.95	2-1/8	2-11/64	2-13/64
	4-1/8" x 1-5/8"	x 4-1/8"	"W 40215	1	5	8.51	2-1/8	4-27/64	2-13/64
	4-1/8" x 1-3/8"	x 4-1/8"	W 40214	1	5	8.57	2-1/8	4-35/64	2-3/16
	4-1/8" x 1-1/8"	x 4-1/8"	W 40213	1	5	9.33	2-1/8	4-43/64	2-13/64
	6-1/8" x 6-1/8"	x 3-1/8"	W 40503	-	1	11	1-3/4	1-3/4	3-47/64
	6-1/8" x 6-1/8"	x 2-5/8"	W 40504	-	1	11.1	1-3/4	1-3/4	4-51/64
	6-1/8" x 6-1/8"	x 2-1/8"	W 40505	-	1	9.54	1-3/4	1-3/4	4-59/64

TUBE & PIPE

METAL FITTINGS & NIPPLES

PLASTIC FITTINGS

VALVES

FILTER-DRIERS & STRAINERS



TEE • FORGED BRASS

COPPER FITTING

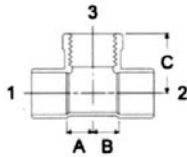
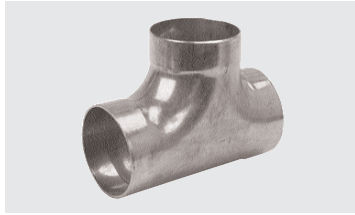

CONNECTION
C x C x F

MUELLER STYLE
WT-602

ELKHART STYLE
N/A

NIBCO STYLE
N/A

I	Size		Part Number	Box Qty.	Master Qty.	Approx. Net.Wt.	Dimensions		
	2	3					A	B	C
	1/4"	1/4" x 1/4"	W 04208*	50	450	.09	7/16	9/16	
	1/4"	1/4" x 1/8"	W 04209*	50	1,200	.04	1/4	27/64	
	3/8"	3/8" x 3/8"	W 04228*	25	350	.15	9/16	21/32	
	3/8"	3/8" x 1/4"	W 04229*	25	400	.10	7/16	5/8	
	3/8"	3/8" x 1/8"	W 04230*	10	400	.11	7/16	9/16	
	1/2"	1/2" x 3/8"	W 04259*	10	240	.15	1/16	23/32	
	5/8"	5/8" x 1/2"	W 04283*	10	150	.33	47/16	1-3/32	

TEE • FITTING

COPPER FITTING

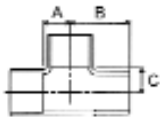

CONNECTION
C x FTG x C

MUELLER STYLE
WT-600F

ELKHART STYLE
111-2

NIBCO STYLE
9611-2

I	Size		Part Number	Box Qty.	Master Qty.	Approx. Net.Wt.	Dimensions		
	2	3					A	B	C
	5/8"		W 04106	50	300	.1	21/64	1-19/64	21/64
	7/8"		W 04131	25	150	.19	15/32	1-25/32	29/64

UNION

COPPER FITTING

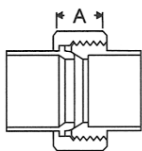
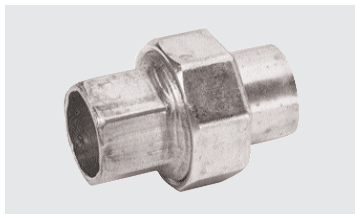

CONNECTION
C x C

MUELLER STYLE
WC-407

ELKHART STYLE
4733

NIBCO STYLE
9633

I	Size		Part Number	Box Qty.	Master Qty.	Approx. Net.Wt.	Dimensions		
	2	3					A	B	C
	3/8"		W 08001	25	250	.12	19/32		
	1/2"		W 08002	25	250	.11	7/16		
	5/8"		W 08003	25	250	.16	15/32		
	7/8"		W 08004	25	150	.37	5/8		
	1-1/8"		W 08005	10	100	.52	29/64		
	1-3/8"		A 11205*	-	25	.75	1/2		
	1-5/8"		A 11206*	-	25	1.04	23/32		
	2-1/8"		A 11207*	-	25	1.77	1/2		
	2-5/8"		A 11216*	-	20	3.25	1		
	3-1/8"		A 11217*	-	15	4.75	1-5/32		

HANGER • HI EAR

COPPER FITTING

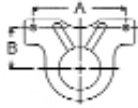

CONNECTION
C

I	Size		Part Number	Box Qty.	Master Qty.	Approx. Net.Wt.	Dimensions		
	2	3					A	B	C
	5/8"		A 03167*	100	1,000	.03	1-5/8	47/64	
	7/8"		A 03168*	25	500	.04	1-5/8	7/8	
	1-1/8"		A 03171*	25	250	.04	1-1/8	1	

COPPER TUBE STRAP • TWO-HOLE

COPPER FITTING



CONNECTION

I	Size		Part Number	Box Qty.	Master Qty.	Approx. Net.Wt.	Dimensions		
	2	3					A	B	C
	1/4"		A 01203	100	4,000	.01			
	3/8"		A 01278	100	5,600	.01			
	1/2"		A 01366	100	3,400	.01			
	5/8"		A 02529	100	1,500	.01			
	3/4"		A 01467	100	2,000	.01			
	7/8"		A 02574	50	750	.01			
	1-1/8"		A 02614	50	750	.02			
	1-3/8"		A 02650	50	500	.04			
	1-5/8"		A 02675	50	500	.05			
	2-1/8"		A 02708	50	500	.06			

COPPER TUBE STRAP • PERFORATED

COPPER FITTING

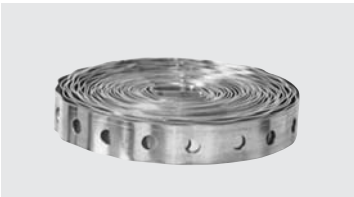

CONNECTION

I	Size	Part Number	Box Qty.	Master Qty.	Approx. Net.Wt.	A	B	C
	25 Ft. Roll	A 01211*	1	10	1.63	.75		

TUBE & PIPE

METAL FITTINGS & NIPPLES

PLASTIC FITTINGS

VALVES

FILTER-DRIERS & STRAINERS



Iron Fittings & Steel Nipples

Mueller boasts an extensive line of black and galvanized malleable iron fittings and steel nipples. Galvanized items are coated for water applications and meet low lead requirements. Fittings are offered from 1/8" – 6" in diameter. Each fitting has the Mueller brand cast into the body, a sign of assured 100% quality inspection and testing.



- Malleable iron fittings meet material: ANSI/ASTM A-197; dimensions: ANSI/ASME B.16.3, B-16.14, B16-39 and Threads: ANSI B1.20.1
- Steel nipples/Pre-Cut Pipe meet material: ANSI/ASTM A.733.A5320; Threads: ANSI B1.20.1
- NAFTA approved Steel Nipples

45° ELBOW

MALLEABLE IRON



Galvanized Part No.	Black Part No.	Size	Inner/Master Carton Qty.	Master Weight (lbs.)
510-200	520-200	1/8"	50/600	45
510-201	520-201	1/4"	35/420	46
510-202	520-202	3/8"	50/300	47
510-203	520-203	1/2"	50/200	45
510-204	520-204	3/4"	40/120	42
510-205	520-205	1"	20/60	35
510-206	520-206	1-1/4"	20/80	68
510-207	520-207	1-1/2"	15/60	67
510-208	520-208	2"	9/36	65
510-209	520-209	2-1/2"	12/24	69
510-210	520-210	3"	5/15	68
510-211	520-211	4"	3/6	45
510-213	520-213	6"	NA/2	36

45° ELBOW • STREET

MALLEABLE IRON



Galvanized Part No.	Black Part No.	Size	Inner/Master Carton Qty.	Master Weight (lbs.)
510-500	520-500	1/8"	50/1200	68
510-501	520-501	1/4"	35/420	36
510-502	520-502	3/8"	50/300	35
510-503	520-503	1/2"	40/240	44
510-504	520-504	3/4"	60/120	39
510-505	520-505	1"	25/75	40
510-506	520-506	1-1/4"	20/80	58
510-507	520-507	1-1/2"	15/60	60
510-508	520-508	2"	9/36	58
510-509	520-509	2-1/2"	NA/13	37
510-510	520-510	3"	3/9	39
510-511	520-511	4"	NA/7	50

90° ELBOW

MALLEABLE IRON



Galvanized Part No.	Black Part No.	Size	Inner/Master Carton Qty.	Master Weight (lbs.)
510-000	520-000	1/8"	50/600	42
510-001	520-001	1/4"	35/420	46
510-002	520-002	3/8"	45/270	46
510-003	520-003	1/2"	50/200	51
510-004	520-004	3/4"	35/105	43
510-005	520-005	1"	20/60	40
510-006	520-006	1-1/4"	20/40	38
510-007	520-007	1-1/2"	15/30	39
510-008	520-008	2"	8/32	64
510-009	520-009	2-1/2"	NA/13	46
510-010	520-010	3"	NA/7	39
510-011	520-011	4"	2/6	56
510-013	520-013	6"	NA/2	42

90° ELBOW • STREET

MALLEABLE IRON



Galvanized Part No.	Black Part No.	Size	Inner/Master Carton Qty.	Master Weight (lbs.)
510-300	520-300	1/8"	50/600	35
510-301	520-301	1/4"	35/420	40
510-302	520-302	3/8"	40/240	37
510-302	520-302	3/8"	40/240	37
510-303	520-303	1/2"	60/180	44
510-304	520-304	3/4"	35/105	40
510-305	520-305	1"	30/60	37
510-306	520-306	1-1/4"	18/72	65
510-307	520-307	1-1/2"	18/54	68
510-308	520-308	2"	10/30	55
510-309	520-309	2-1/2"	6/18	61
510-310	520-310	3"	NA/7	39
510-311	520-311	4"	2/6	59

TUBE & PIPE

METAL FITTINGS & NIPPLES

PLASTIC FITTINGS

VALVES

FILTER-DRIERS & STRAINERS



EXTENSION PIECE

MALLEABLE IRON



Galvanized Part No.	Black Part No.	Size	Inner/Master Carton Qty.	Master Weight (lbs.)
511-613	—	1/2"	50/300	48
511-614	—	3/4"	60/180	47

ELBOW • REDUCING

MALLEABLE IRON



Galvanized Part No.	Black Part No.	Size	Inner/Master Carton Qty.	Master Weight (lbs.)
510-120	520-120	3/8" x 1/8"	60/360	45
510-121	520-121	3/8" x 1/4"	60/360	53
510-110	520-110	1/4" x 1/8"	60/360	35
510-130	520-130	1/2" x 1/8"	40/480	69
510-131	520-131	1/2" x 1/4"	40/240	47
510-132	520-132	1/2" x 3/8"	50/200	43
510-141	520-141	3/4" x 1/4"	50/150	38
510-142	520-142	3/4" x 3/8"	50/150	44
510-143	520-143	3/4" x 1/2"	40/120	42
510-144	520-144	1" x 1/2"	30/90	43
510-151	520-151	1" x 1/4"	25/150	56
510-152	520-152	1" x 3/8"	25/150	62
510-154	520-154	1" x 3/4"	25/75	41
510-163	520-163	1-1/4" x 1/2"	35/70	37
510-164	520-164	1-1/4" x 3/4"	30/60	41
510-165	520-165	1-1/4" x 1"	20/40	35
510-157	520-157	1-1/2" x 1"	20/40	41
510-173	520-173	1-1/2" x 1/2"	25/50	36
510-174	520-174	1-1/2" x 3/4"	15/45	40
510-176	520-176	1-1/2" x 1-1/4"	15/60	69
510-183	520-183	2" x 1/2"	15/60	105
510-184	520-184	2" x 3/4"	15/30	39
510-185	520-185	2" x 1"	14/28	38
510-186	520-186	2" x 1-1/4"	10/40	61
510-187	520-187	2" x 1-1/2"	10/40	66
510-194	520-194	2-1/2" x 3/4"	15/30	66
510-195	520-195	2-1/2" x 1"	15/30	68
510-196	520-196	2-1/2" x 1-1/4"	NA/15	36
510-197	520-197	2-1/2" x 1-1/2"	NA/15	39
510-198	520-198	2-1/2" x 2"	5/15	43
510-115	520-115	3" x 1"	10/20	59
510-116	520-116	3" x 1-1/4"	10/20	60
510-117	520-117	3" x 1-1/2"	10/20	66
510-118	520-118	3" x 2"	NA/10	37
510-119	520-119	3" x 2-1/2"	NA/8	24
510-111	520-111	4" x 2"	NA/6	36
510-113	520-113	4" x 2-1/2"	4/8	51
510-112	520-112	4" x 3"	3/9	69

ELBOW • SIDE OUTLET

MALLEABLE IRON



Galvanized Part No.	Black Part No.	Size	Inner/Master Carton Qty.	Master Weight (lbs.)
510-803	520-803	1/2"	45/135	46
510-804	520-804	3/4"	40/80	41
510-805	520-805	1"	20/80	59
510-806	520-806	1-1/4"	15/45	54
510-807	520-807	1-1/2"	18/36	50
510-808	520-808	2"	12/24	39

TEE

MALLEABLE IRON



Galvanized Part No.	Black Part No.	Size	Inner/Master Carton Qty.	Master Weight (lbs.)
510-600	520-600	1/8"	75/450	43
510-601	520-601	1/4"	50/300	47
510-602	520-602	3/8"	45/180	41
510-603	520-603	1/2"	40/120	44
510-604	520-604	3/4"	35/70	42
510-605	520-605	1"	20/40	37
510-606	520-606	1-1/4"	14/28	39
510-607	520-607	1-1/2"	NA/23	41
510-608	520-608	2"	5/15	42
510-609	520-609	2-1/2"	NA/9	40
510-610	520-610	3"	NA/6	44
510-611	520-611	4"	NA/3	38
510-613	520-613	6"	NA/2	55

SERVICE TEES

MALLEABLE IRON



Galvanized Part No.	Black Part No.	Size	Inner/Master Carton Qty.	Master Weight (lbs.)
510-683	520-683	1/2"	60/240	70
510-684	520-684	3/4"	50/150	72
510-685	—	1"	20/80	62

TUBE & PIPE

METAL FITTINGS & NIPPLES

PLASTIC FITTINGS

VALVES

FILTER-DRIERS & STRAINERS



TEE • REDUCING

MALLEABLE IRON

TUBE & PIPE

METAL FITTINGS & NIPPLES

PLASTIC FITTINGS

VALVES

FILTER-DRIVERS & STRAINERS



Galvanized Part No.	Black Part No.	Size	Inner/Master Carton Qty.	Master Weight (lbs.)
510-229	520-229	1/4" x 1/8"	50/300	38
510-220	520-220	3/8" x 1/8"	60/240	40
510-221	520-221	3/8" x 1/4"	60/240	55
510-330	520-330	1/2" x 1/8"	60/180	46
510-331	520-331	1/2" x 1/4"	50/150	41
510-322	520-322	1/2" x 3/8"	45/135	40
510-334	520-334	1/2" x 1/2" x 3/4"	45/90	39
510-335	520-335	1/2" x 1/2" x 1"	30/120	64
510-444	520-444	3/4" x 1/4"	50/100	40
510-442	520-442	3/4" x 3/8"	45/90	39
510-743	520-743	3/4" x 1/2"	45/90	45
510-433	520-433	3/4" x 1/2" x 1/2"	45/90	40
510-434	520-434	3/4" x 1/2" x 3/4"	45/90	46
510-435	520-435	3/4" x 1/2" x 1"	45/90	59
510-445	520-445	3/4" x 3/4" x 1"	25/50	35
510-446	520-446	3/4" x 3/4" x 1-1/4"	18/72	63
510-551	520-551	1" x 1/4"	25/100	61
510-552	520-552	1" x 3/8"	20/60	41
510-753	520-753	1" x 1/2"	20/60	43
510-754	520-754	1" x 3/4"	25/50	40
510-533	520-533	1" x 1/2" x 1/2"	20/120	67
510-534	520-534	1" x 1/2" x 3/4"	25/100	61
510-793	520-793	1" x 1/2" x 1"	20/60	46
510-543	520-543	1" x 3/4" x 1/2"	25/100	62
510-544	520-544	1" x 3/4" x 3/4"	25/50	35
510-545	—	1" x 3/4" x 1"	25/50	39
—	520-794	1" x 3/4" x 1"	25/50	39
510-556	520-556	1" x 1" x 1-1/4"	18/36	38
510-557	520-557	1" x 1" x 1-1/2"	13/52	61
510-558	520-558	1" x 1" x 2"	9/36	64
510-662	520-662	1-1/4" x 3/8"	16/64	53
510-663	520-663	1-1/4" x 1/2"	16/64	60
510-664	520-664	1-1/4" x 3/4"	18/36	38
510-765	520-765	1-1/4" x 1"	16/32	38
510-633	520-633	1-1/4" x 1/2" x 1/2"	16/64	46
510-634	520-634	1-1/4" x 1/2" x 3/4"	18/72	54
510-635	520-635	1-1/4" x 1/2" x 1"	18/72	58
510-636	520-636	1-1/4" x 1/2" x 1-1/4"	16/64	68
510-643	520-643	1-1/4" x 3/4" x 1/2"	18/72	60
510-644	520-644	1-1/4" x 3/4" x 3/4"	18/72	61
510-645	520-645	1-1/4" x 3/4" x 1"	16/64	64
510-646	520-646	1-1/4" x 3/4" x 1-1/4"	16/32	36
510-653	520-653	1-1/4" x 1" x 1/2"	18/72	58
510-654	520-654	1-1/4" x 1" x 3/4"	18/72	66
510-655	520-655	1-1/4" x 1" x 1"	18/36	37
510-656	520-656	1-1/4" x 1" x 1-1/4"	15/30	45
510-657	520-657	1-1/4" x 1" x 1-1/2"	15/30	65
510-658	520-658	1-1/4" x 1-1/4" x 1-1/2"	11/44	69
510-659	520-659	1-1/4" x 1-1/4" x 2"	8/32	56
510-772	520-772	1-1/2" x 3/8"	18/36	42
510-773	520-773	1-1/2" x 1/2"	18/36	43
510-774	520-774	1-1/2" x 3/4"	15/30	40
510-775	—	1-1/2" x 1"	13/26	71
510-776	520-776	1-1/2" x 1-1/4"	NA/23	39
—	520-766	1-1/2" x 1"	13/52	76
510-734	520-734	1-1/2" x 1/2" x 3/4"	15/60	58
510-735	520-735	1-1/2" x 1/2" x 1"	13/52	53
510-736	520-736	1-1/2" x 1/2" x 1-1/4"	11/44	57
510-737	520-737	1-1/2" x 1/2" x 1-1/2"	18/36	49



TEE • REDUCING continued

MALLEABLE IRON



Galvanized Part No.	Black Part No.	Size	Inner/Master Carton Qty.	Master Weight (lbs.)
510-748	520-748	1-1/2" x 3/4" x 1/2"	15/60	58
510-744	520-744	1-1/2" x 3/4" x 3/4"	15/60	61
510-746	520-746	1-1/2" x 3/4" x 1-1/4"	11/44	57
510-747	520-747	1-1/2" x 3/4" x 1-1/2"	15/30	43
510-758	520-758	1-1/2" x 1" x 1/2"	13/52	58
510-759	520-759	1-1/2" x 1" x 3/4"	13/52	70
510-755	520-755	1-1/2" x 1" x 1"	13/52	61
510-756	520-756	1-1/2" x 1" x 1-1/4"	11/44	61
510-757	520-757	1-1/2" x 1" x 1-1/2"	13/26	39
510-763	520-763	1-1/2" x 1-1/4" x 1/2"	11/44	50
510-764	520-764	1-1/2" x 1-1/4" x 3/4"	11/44	52
510-767	520-767	1-1/2" x 1-1/4" x 1-1/2"	11/44	68
510-768	520-768	1-1/2" x 1-1/4" x 1"	11/44	59
510-769	520-769	1-1/2" x 1-1/4" x 1-1/4"	11/44	66
510-783	520-783	2" x 1/2"	10/40	69
510-884	520-884	2" x 3/4"	9/36	69
510-785	520-785	2" x 1"	9/18	37
510-886	520-886	2" x 1-1/4"	8/16	36
510-787	520-787	2" x 1-1/2"	8/16	39
510-778	520-778	2" x 1-1/2" x 2"	8/32	66
510-838	520-838	2" x 1/2" x 2"	8/32	66
510-844	520-844	2" x 3/4" x 3/4"	9/36	47
510-848	520-848	2" x 3/4" x 2"	8/32	68
510-855	520-855	2" x 1" x 1"	9/36	57
510-857	520-857	2" x 1" x 1-1/2"	8/32	66
510-858	520-858	2" x 1" x 2"	10/20	45
510-865	520-865	2" x 1-1/4" x 1"	8/32	53
510-866	520-866	2" x 1-1/4" x 1-1/4"	8/32	58
510-867	520-867	2" x 1-1/4" x 1-1/2"	8/32	63
510-868	520-868	2" x 1-1/4" x 2"	8/16	39
510-874	520-874	2" x 1-1/2" x 3/4"	8/32	50
510-875	520-875	2" x 1-1/2" x 1"	8/32	57
510-876	520-876	2" x 1-1/2" x 1-1/4"	8/32	61
510-877	520-877	2" x 1-1/2" x 1-1/2"	8/16	35
510-878	520-878	2" x 1-1/2" x 2"	8/16	37
510-889	520-889	2" x 2" x 2-1/2"	10/20	68
510-993	520-993	2-1/2" x 1/2"	10/20	62
510-994	520-994	2-1/2" x 3/4"	10/20	60

COUPLING

MALLEABLE IRON



Galvanized Part No.	Black Part No.	Size	Inner/Master Carton Qty.	Master Weight (lbs.)
511-200	521-200	1/8"	60/720	43
511-201	521-201	1/4"	40/480	42
511-202	521-202	3/8"	50/300	39
511-203	521-203	1/2"	60/240	47
511-204	521-204	3/4"	50/150	47
511-205	521-205	1"	25/75	37
511-206	521-206	1-1/4"	32/64	45
511-207	521-207	1-1/2"	18/72	69
511-208	521-208	2"	12/24	36
511-209	521-209	2-1/2"	NA/16	43
511-210	521-210	3"	NA/12	46
511-211	521-211	4"	NA/7	46
511-213	521-213	6"	2/4	50



COUPLING • REDUCING

MALLEABLE IRON

TUBE & PIPE

METAL FITTINGS & NIPPLES

PLASTIC FITTINGS

VALVES

FILTER-DRIERS & STRAINERS



Galvanized Part No.	Black Part No.	Size	Inner/Master Carton Qty.	Master Weight (lbs.)
511-310	521-310	1/4" x 1/8"	25/600	49
511-320	521-320	3/8" x 1/8"	30/360	38
511-321	521-321	3/8" x 1/4"	30/360	41
511-330	521-330	1/2" x 1/8"	50/300	41
511-331	521-331	1/2" x 1/4"	50/300	46
511-332	521-332	1/2" x 3/8"	40/240	41
511-340	521-340	3/4" x 1/8"	35/210	46
511-341	521-341	3/4" x 1/4"	30/180	41
511-342	521-342	3/4" x 3/8"	30/180	65
511-343	521-343	3/4" x 1/2"	60/180	49
511-351	521-351	1" x 1/4"	25/200	69
511-352	521-352	1" x 3/8"	40/120	44
511-353	521-353	1" x 1/2"	30/120	48
511-354	521-354	1" x 3/4"	30/120	55
511-362	521-362	1-1/4" x 3/8"	50/100	52
511-363	521-363	1-1/4" x 1/2"	25/75	40
511-364	521-364	1-1/4" x 3/4"	25/75	45
511-365	521-365	1-1/4" x 1"	25/75	50
511-372	521-372	1-1/2" x 3/8"	20/120	48
511-373	521-373	1-1/2" x 1/2"	20/60	42
511-374	521-374	1-1/2" x 3/4"	30/60	44
511-375	521-375	1-1/2" x 1"	30/60	50
511-376	521-376	1-1/2" x 1-1/4"	25/50	47
511-383	521-383	2" x 1/2"	21/42	47
511-384	521-384	2" x 3/4"	21/42	48
511-385	521-385	2" x 1"	14/28	35
511-386	521-386	2" x 1-1/4"	14/28	37
511-387	521-387	2" x 1-1/2"	14/28	38
511-394	521-394	2 1/2" x 3/4"	NA/20	35
511-395	521-395	2-1/2" x 1"	16/32	59
511-396	521-396	2-1/2" x 1-1/4"	16/32	60
511-397	521-397	2-1/2" x 1-1/2"	16/32	67
511-398	521-398	2-1/2" x 2"	16/32	66
511-304	521-304	3" x 3/4"	NA/24	58
511-305	521-305	3" x 1"	12/24	63
511-306	521-306	3" x 1-1/4"	12/24	64
511-307	521-307	3" x 1-1/2"	12/24	68
511-308	521-308	3" x 2"	7/14	42
511-309	521-309	3" x 2-1/2"	NA/12	41
511-325	521-325	4" x 1"	NA/9	36
511-326	521-326	4" x 1-1/4"	NA/9	41
511-327	521-327	4" x 1-1/2"	NA/9	39
511-328	521-328	4" x 2"	NA/9	43
511-329	521-329	4" x 2-1/2"	NA/9	47
511-300	521-300	4" x 3"	NA/7	40
511-323	521-323	6" x 4"	NA/4	38
511-322	521-322	6" x 3"	NA/4	41



COUPLING • MERCHANT

MALLEABLE IRON



Galvanized Part No.	Black Part No.	Size	Inner/Master Carton Qty.	Master Weight (lbs.)
511-220	521-220	1/8"	60/720	23
511-221	521-221	1/4"	60/720	54
511-222	521-222	3/8"	50/600	58
511-223	521-223	1/2"	40/480	101
511-224	521-224	3/4"	50/300	85
511-225	521-225	1"	25/150	50
511-226	521-226	1-1/4"	16/128	64
511-227	521-227	1-1/2"	18/72	44
511-228	521-228	2"	12/48	40
511-229	—	2-1/2"	NA/16	40
511-230	—	3"	NA/12	41
511-231	—	4"	NA/7	31

CAP

MALLEABLE IRON



Galvanized Part No.	Black Part No.	Size	Inner/Master Carton Qty.	Master Weight (lbs.)
511-400	521-400	1/8"	100/1200	42
511-401	521-401	1/4"	75/900	56
511-402	521-402	3/8"	60/720	64
511-403	521-403	1/2"	75/450	58
511-404	521-404	3/4"	40/240	51
511-405	521-405	1"	35/140	46
511-406	521-406	1-1/4"	25/100	49
511-407	521-407	1-1/2"	25/75	47
511-408	521-408	2"	18/54	51
511-409	521-409	2-1/2"	NA/24	38
511-410	521-410	3"	NA/16	38
511-411	521-411	4"	NA/10	41
511-413	521-413	6"	NA/5	44

PLUG

MALLEABLE IRON

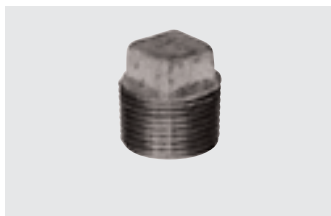

Galvanized Part No.	Black Part No.	Size	Inner/Master Carton Qty.	Master Weight (lbs.)
511-800	521-800	1/8"	225/2700	52
511-801	521-801	1/4"	150/1800	54
511-802	521-802	3/8"	100/1200	63
511-803	521-803	1/2"	25/600	51
511-804	521-804	3/4"	15/360	50
511-805	521-805	1"	20/240	59
511-806	521-806	1-1/4"	40/120	48
511-807	521-807	1-1/2"	30/90	48
511-808	521-808	2"	30/60	50
511-809	521-809	2-1/2"	NA/32	37
511-810	521-810	3"	NA/24	43
511-811	521-811	4"	NA/16	45
511-813	521-813	6"	NA/10	71

TUBE & PIPE

METAL FITTINGS & NIPPLES

PLASTIC FITTINGS

VALVES

FILTER-DRIERS & STRAINERS



HEX BUSHING

MALLEABLE IRON

TUBE & PIPE



METAL FITTINGS & NIPLLES

PLASTIC FITTINGS

VALVES

FILTER-DRIERS & STRAINERS

Galvanized Part No.	Black Part No.	Size	Inner/Master Carton Qty.	Master Weight (lbs.)
511-910	521-910	1/4" x 1/8"	100/1200	65
511-920	521-920	3/8" x 1/8"	75/900	40
511-921	521-921	3/8" x 1/4"	75/900	39
511-930	521-930	1/2" x 1/8"	150/600	58
511-931	521-931	1/2" x 1/4"	100/600	54
511-932	521-932	1/2" x 3/8"	100/600	43
511-940	521-940	3/4" x 1/8"	50/300	44
511-941	521-941	3/4" x 1/4"	50/300	50
511-942	521-942	3/4" x 3/8"	50/300	46
511-943	521-943	3/4" x 1/2"	50/300	39
511-951	521-951	1" x 1/4"	50/200	41
511-952	521-952	1" x 3/8"	50/200	54
511-953	521-953	1" x 1/2"	50/200	50
511-954	521-954	1" x 3/4"	50/200	39
511-961	521-961	1-1/4" x 1/4"	30/240	69
511-962	521-962	1-1/4" x 3/8"	30/240	67
511-963	521-963	1-1/4" x 1/2"	30/120	57
511-964	521-964	1-1/4" x 3/4"	30/120	107
511-965	521-965	1-1/4" x 1"	30/120	39
511-971	521-971	1-1/2" x 1/4"	25/150	61
511-972	521-972	1-1/2" x 3/8"	25/150	62
511-973	521-973	1-1/2" x 1/2"	25/75	49
511-974	521-974	1-1/2" x 3/4"	25/75	43
511-975	521-975	1-1/2" x 1"	25/75	43
511-976	521-976	1-1/2" x 1-1/4"	25/150	50
511-982	521-982	2" x 3/8"	20/60	39
511-983	521-983	2" x 1/2"	20/60	54
511-984	521-984	2" x 3/4"	20/60	62
511-985	521-985	2" x 1"	20/60	63
511-986	521-986	2" x 1-1/4"	20/60	51
511-987	521-987	2" x 1-1/2"	20/60	42
511-993	521-993	2-1/2" x 1/2"	30/60	59
511-994	521-994	2-1/2" x 3/4"	24/48	41
511-995	521-995	2-1/2" x 1"	24/48	46
511-996	521-996	2-1/2" x 1-1/4"	24/48	52
511-997	521-997	2-1/2" x 1-1/2"	0/28	33
511-998	521-998	2-1/2" x 2"	24/48	51
511-903	521-903	3" x 1/2"	24/48	75
511-904	521-904	3" x 3/4"	NA/24	35
511-905	521-905	3" x 1"	16/32	44
511-906	521-906	3" x 1-1/4"	16/32	49
511-907	521-907	3" x 1-1/2"	16/32	51
511-908	521-908	3" x 2"	0/16	40
511-909	521-909	3" x 2-1/2"	16/32	53
511-914	521-914	4" x 3/4"	10/20	50
511-915	521-915	4" x 1"	10/20	51
511-916	521-916	4" x 1-1/4"	10/20	47
511-917	521-917	4" x 1-1/2"	10/20	47
511-918	521-918	4" x 2"	10/20	58
511-919	521-919	4" x 2-1/2"	NA/10	46
511-900	521-900	4" x 3"	NA/10	35
511-938	521-938	6" x 2"	NA/10	67
511-939	521-939	6" x 3"	NA/10	70
511-937	521-937	6" x 4"	NA/10	74



UNION

MALLEABLE IRON



Galvanized Part No.	Black Part No.	Size	Inner/Master Carton Qty.	Master Weight (lbs.)
511-700	521-700	1/8"	20/240	41
511-701	521-701	1/4"	30/180	46
511-702	521-702	3/8"	35/140	48
511-703	521-703	1/2"	25/100	49
511-704	521-704	3/4"	20/60	39
511-705	521-705	1"	15/45	44
511-706	521-706	1-1/4"	15/30	41
511-707	521-707	1-1/2"	10/20	36
511-708	521-708	2"	6/24	64
511-709	521-709	2-1/2"	8/16	67
511-710	521-710	3"	5/10	58
511-711	521-711	4"	3/6	62

FLANGE

MALLEABLE IRON



Galvanized Part No.	Black Part No.	Size	Inner/Master Carton Qty.	Master Weight (lbs.)
511-601	521-601	1/4"	50/200	61
511-602	521-602	3/8"	35/140	40
511-603	521-603	1/2"	25/100	40
511-604	521-604	3/4"	20/80	43
511-605	521-605	1"	20/60	48
511-606	521-606	1-1/4"	15/45	45
511-607	521-607	1-1/2"	12/36	46
511-608	521-608	2"	8/24	44
511-610	521-610	3"	24/48	48

TUBE & PIPE

METAL FITTINGS & NIPPLES

PLASTIC FITTINGS

VALVES

FILTER-DRIERS & STRAINERS



CROSS**MALLEABLE IRON**

Galvanized Part No.	Black Part No.	Size	Inner/Master Carton Qty.	Master Weight (lbs.)
511-000	521-000	1/8"	60/360	
511-001	521-001	1/4"	45/270	53
511-002	521-002	3/8"	45/135	37
511-003	521-003	1/2"	45/90	39
511-004	521-004	3/4"	30/60	40
511-005	521-005	1"	16/32	38
511-006	521-006	1-1/4"	9/36	57
511-007	521-007	1-1/2"	8/32	65
511-008	521-008	2"	5/20	64
511-009	521-009	2-1/2"	6/12	61
511-010	521-010	3"	4/8	66
511-011	521-011	4"	2/4	55

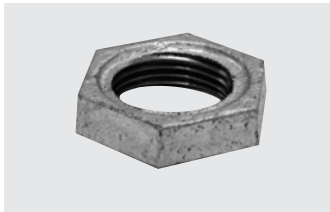
LOCKNUT**MALLEABLE IRON**

Galvanized Part No.	Black Part No.	Size	Inner/Master Carton Qty.	Master Weight (lbs.)
510-900	520-900	1/8"	250/3000	45
510-901	520-901	1/4"	125/1500	42
510-902	520-902	3/8"	125/1500	69
510-903	520-903	1/2"	100/600	39
510-904	520-904	3/4"	60/360	36
510-905	520-905	1"	60/240	40
510-906	520-906	1-1/4"	60/180	41
510-907	520-907	1-1/2"	40/160	42
510-908	520-908	2"	25/150	81
510-909	520-909	2-1/2"	40/80	57

NIPPLES

STANDARD WELDED STEEL



1/8"

Galvanized Part No.	Black Part No.	Description	Weight Approx. (Lbs.)	Weight Approx.		Inner/Master Wt.(Lbs.)
				Inner Box	Master Ctn.	
560-001	580-001	1/8" x Close	0.02	25	100	1.8
560-015	580-015	1/8" x 1-1/2"	0.03	25	100	3.1
560-020	580-020	1/8" x 2"	0.04	25	100	4.2
560-025	580-025	1/8" x 2-1/2"	0.05	25	100	5.1
560-030	580-030	1/8" x 3"	0.06	25	100	6.2
560-035	580-035	1/8" x 3-1/2"	0.07	25	100	7.3
560-040	580-040	1/8" x 4"	0.08	25	100	8.4
560-045	580-045	1/8" x 4-1/2"	0.09	25	100	9.3
560-050	580-050	1/8" x 5"	0.10	25	100	10.4
560-055	580-055	1/8" x 5-1/2"	0.11	25	100	11.5
560-060	580-060	1/8" x 6"	0.12	25	100	12.4
560-080	580-080	1/8" x 8"	0.17	25	-	4.1
560-100	580-100	1/8" x 10"	0.21	25	-	5.2
560-120	580-120	1/8" x 12"	0.25	25	-	6.2



1/4"

Galvanized Part No.	Black Part No.	Description	Weight Approx. (Lbs.)	Weight Approx.		Inner/Master Wt.(Lbs.)
				Inner Box	Master Ctn.	
561-001	581-001	1/4" x Close	0.03	25	100	3.1
561-015	581-015	1/4" x 1-1/2"	0.05	25	100	5.3
561-020	581-020	1/4" x 2"	0.07	25	100	7.1
561-025	581-025	1/4" x 2-1/2"	0.09	25	100	8.8
561-030	581-030	1/4" x 3"	0.11	25	100	10.6
561-035	581-035	1/4" x 3-1/2"	0.12	25	100	12.4
561-040	581-040	1/4" x 4"	0.14	25	100	14.1
561-045	581-045	1/4" x 4-1/2"	0.16	25	100	15.9
561-050	581-050	1/4" x 5"	0.18	25	100	17.6
561-055	581-055	1/4" x 5-1/2"	0.19	25	100	19.4
561-060	581-060	1/4" x 6"	0.21	25	100	21.2
561-080	581-080	1/4" x 8"	0.28	25	-	7.1
561-100	581-100	1/4" x 10"	0.35	25	-	8.8
561-120	581-120	1/4" x 12"	0.42	25	-	10.6

TUBE & PIPE

METAL FITTINGS & NIPPLES

PLASTIC FITTINGS

VALVES

FILTER-DRIERS & STRAINERS



NIPPLES

STANDARD WELDED STEEL

**3/8"**

Galvanized Part No.	Black Part No.	Description	Weight Approx. (Lbs.)	Inner Box	Master Ctn.	Inner/Master Wt.(Lbs.)
562-001	582-001	3/8" x Close	0.05	25	100	4.6
562-015	582-015	3/8" x 1-1/2"	0.07	25	100	7.1
562-020	582-020	3/8" x 2"	0.09	25	100	9.5
562-025	582-025	3/8" x 2-1/2"	0.12	25	100	11.7
562-030	582-030	3/8" x 3"	0.14	25	100	14.1
562-035	582-035	3/8" x 3-1/2"	0.17	25	100	16.5
562-040	582-040	3/8" x 4"	0.19	25	100	18.7
562-045	582-045	3/8" x 4-1/2"	0.21	25	100	21.2
562-050	582-050	3/8" x 5"	0.24	25	100	23.6
562-055	582-055	3/8" x 5-1/2"	0.26	25	100	25.8
562-060	582-060	3/8" x 6"	0.28	25	100	28.2
562-080	582-080	3/8" x 8"	0.38	25	-	9.4
562-100	582-100	3/8" x 10"	0.47	25	-	11.7
562-120	582-120	3/8" x 12"	0.56	25	-	14.1

1/2"

Galvanized Part No.	Black Part No.	Description	Weight Approx. (Lbs.)	Inner Box	Master Ctn.	Inner/Master Wt.(Lbs.)
563-001	583-001	1/2" x Close	0.08	25	100	7.9
563-015	583-015	1/2" x 1-1/2"	0.11	25	100	10.6
563-020	583-020	1/2" x 2"	0.14	25	100	14.3
563-025	583-025	1/2" x 2-1/2"	0.18	25	-	4.5
563-030	583-030	1/2" x 3"	0.21	25	-	5.3
563-035	583-035	1/2" x 3-1/2"	0.25	25	-	6.2
563-040	583-040	1/2" x 4"	0.28	25	-	7.1
563-045	583-045	1/2" x 4-1/2"	0.32	25	-	8.0
563-050	583-050	1/2" x 5"	0.35	25	-	8.9
563-055	583-055	1/2" x 5-1/2"	0.39	25	-	9.8
563-060	583-060	1/2" x 6"	0.43	25	-	10.7
563-070	583-070	1/2" x 7"	0.50	25	-	12.5
563-080	583-080	1/2" x 8"	0.57	25	-	14.2
563-090	583-090	1/2" x 9"	0.64	25	-	16.0
563-100	583-100	1/2" x 10"	0.71	25	-	17.8
563-110	583-110	1/2" x 11"	0.78	25	-	19.6
563-120	583-120	1/2" x 12"	0.85	25	-	21.3

3/4"

Galvanized Part No.	Black Part No.	Description	Weight Approx. (Lbs.)	Inner Box	Master Ctn.	Inner/Master Wt.(Lbs.)
564-001	584-001	3/4" x Close	0.13	25	100	13.0
564-015	584-015	3/4" x 1-1/2"	0.14	25	100	14.1
564-020	584-020	3/4" x 2"	0.19	25	-	4.7
564-025	584-025	3/4" x 2-1/2"	0.24	25	-	5.9
564-030	584-030	3/4" x 3"	0.28	25	-	7.1
564-035	584-035	3/4" x 3-1/2"	0.33	25	-	8.3
564-040	584-040	3/4" x 4"	0.38	25	-	9.5
564-045	584-045	3/4" x 4-1/2"	0.43	25	-	10.6
564-050	584-050	3/4" x 5"	0.47	25	-	11.9
564-055	584-055	3/4" x 5-1/2"	0.52	25	-	13.0
564-060	584-060	3/4" x 6"	0.57	25	-	14.2
564-070	584-070	3/4" x 7"	0.66	25	-	16.5
564-080	584-080	3/4" x 8"	0.76	25	-	18.9
564-090	584-090	3/4" x 9"	0.85	25	-	21.3
564-100	584-100	3/4" x 10"	0.95	25	-	23.6
564-110	584-110	3/4" x 11"	1.04	25	-	26.0
564-120	584-120	3/4" x 12"	1.14	25	-	28.4

NIPPLES

STANDARD WELDED STEEL



1"



Galvanized Part No.	Black Part No.	Description	Weight Approx. (Lbs.)	Inner Box	Master Ctn.	Inner/Master Wt.(Lbs.)
565-001	585-001	1" x Close	0.21	25	-	5.2
565-020	585-020	1" x 2"	0.28	25	-	7.0
565-025	585-025	1" x 2-1/2"	0.35	25	-	8.8
565-030	585-030	1" x 3"	0.42	25	-	10.5
565-035	585-035	1" x 3-1/2"	0.49	25	-	12.2
565-040	585-040	1" x 4"	0.56	25	-	14.0
565-045	585-045	1" x 4-1/2"	0.63	25	-	15.8
565-050	585-050	1" x 5"	0.70	25	-	17.5
565-055	585-055	1" x 5-1/2"	0.77	25	-	19.2
565-060	585-060	1" x 6"	0.84	25	-	21.0
565-070	585-070	1" x 7"	0.98	25	-	24.5
565-080	585-080	1" x 8"	1.12	25	-	28.0
565-090	585-090	1" x 9"	1.26	25	-	31.5
565-100	585-100	1" x 10"	1.40	25	-	35.0
565-110	585-110	1" x 11"	1.54	25	-	38.5
565-120	585-120	1" x 12"	1.68	25	-	42.0

1-1/4"

Galvanized Part No.	Black Part No.	Description	Weight Approx. (Lbs.)	Inner Box	Master Ctn.	Inner/Master Wt.(Lbs.)
566-001	586-001	1-1/4" x Close	0.31	25	-	7.7
566-020	586-020	1-1/4" x 2"	0.38	25	-	9.5
566-025	586-025	1-1/4" x 2-1/2"	0.47	25	-	11.9
566-030	586-030	1-1/4" x 3"	0.57	25	-	14.2
566-035	586-035	1-1/4" x 3-1/2"	0.66	25	-	16.6
566-040	586-040	1-1/4" x 4"	0.76	25	-	19.0
566-045	586-045	1-1/4" x 4-1/2"	0.85	25	-	21.3
566-050	586-050	1-1/4" x 5"	0.95	25	-	23.7
566-055	586-055	1-1/4" x 5-1/2"	1.05	25	-	26.1
566-060	586-060	1-1/4" x 6"	1.14	25	-	28.5
566-070	586-070	1-1/4" x 7"	1.33	25	-	33.2
566-080	586-080	1-1/4" x 8"	1.52	25	-	38.0
566-090	586-090	1-1/4" x 9"	1.71	25	-	42.7
566-100	586-100	1-1/4" x 10"	1.90	25	-	47.5
566-110	586-110	1-1/4" x 11"	2.09	10	-	20.9
566-120	586-120	1-1/4" x 12"	2.28	10	-	22.8

1-1/2"

Galvanized Part No.	Black Part No.	Description	Weight Approx. (Lbs.)	Inner Box	Master Ctn.	Inner/Master Wt.(Lbs.)
567-001	587-001	1-1/2" x Close	0.40	25	-	9.9
567-020	587-020	1-1/2" x 2"	0.45	25	-	11.4
567-025	587-025	1-1/2" x 2-1/2"	0.57	25	-	14.2
567-030	587-030	1-1/2" x 3"	0.68	25	-	17.0
567-035	587-035	1-1/2" x 3-1/2"	0.79	25	-	19.8
567-040	587-040	1-1/2" x 4"	0.91	25	-	22.7
567-045	587-045	1-1/2" x 4-1/2"	1.02	25	-	25.5
567-050	587-050	1-1/2" x 5"	1.13	25	-	28.3
567-055	587-055	1-1/2" x 5-1/2"	1.25	25	-	31.2
567-060	587-060	1-1/2" x 6"	1.36	25	-	34.0
567-070	587-070	1-1/2" x 7"	1.59	10	-	15.9
567-080	587-080	1-1/2" x 8"	1.81	10	-	18.1
567-090	587-090	1-1/2" x 9"	2.04	10	-	20.4
567-100	587-100	1-1/2" x 10"	2.27	10	-	22.7
567-110	587-110	1-1/2" x 11"	2.49	10	-	24.9
567-120	587-120	1-1/2" x 12"	2.72	10	-	27.2



NIPPLES

STANDARD WELDED STEEL



2"

Galvanized Part No.	Black Part No.	Description	Weight Approx. (Lbs.)	Inner Box	Master Ctn.	Inner/Master Wt.(Lbs.)
568-001	588-001	2" x Close	0.61	25	-	15.2
568-025	588-025	2" x 2-1/2"	0.76	25	-	19.0
568-030	588-030	2" x 3"	0.91	25	-	22.8
568-035	588-035	2" x 3-1/2"	1.07	25	-	26.7
568-040	588-040	2" x 4"	1.22	25	-	30.5
568-045	588-045	2" x 4-1/2"	1.37	25	-	34.3
568-050	588-050	2" x 5"	1.52	25	-	38.1
568-055	588-055	2" x 5-1/2"	1.68	25	-	41.9
568-060	588-060	2" x 6"	1.83	25	-	45.7
568-070	588-070	2" x 7"	2.13	10	-	21.3
568-080	588-080	2" x 8"	2.44	10	-	24.4
568-090	588-090	2" x 9"	2.74	10	-	27.4
568-100	588-100	2" x 10"	3.05	10	-	30.5
568-110	588-110	2" x 11"	3.35	10	-	33.5
568-120	588-120	2" x 12"	3.66	10	-	36.6

2-1/2"

Galvanized Part No.	Black Part No.	Description	Weight Approx. (Lbs.)	Inner Box	Master Ctn.	Inner/Master Wt.(Lbs.)
569-001	—	2-1/2" x Close	1.21	10	-	12.1
569-030	—	2-1/2" x 3"	1.45	10	-	14.5
569-040	—	2-1/2" x 4"	1.93	10	-	19.3
569-050	—	2-1/2" x 5"	2.42	10	-	24.2
569-060	—	2-1/2" x 6"	2.90	10	-	29.0
569-080	—	2-1/2" x 8"	3.86	10	-	38.6
569-100	—	2-1/2" x 10"	4.83	5	-	24.2
569-120	—	2-1/2" x 12"	5.80	5	-	29.0

3"

Galvanized Part No.	Black Part No.	Description	Weight Approx. (Lbs.)	Inner Box	Master Ctn.	Inner/Master Wt.(Lbs.)
570-001	—	3" x Close	1.66	10	-	16.6
570-030	590-030	3" x 3"	1.90	10	-	19.0
—	590-035	3" x 3-1/2"	2.53	10	-	25.3
570-040	590-040	3" x 4"	2.53	10	-	25.3
570-050	590-050	3" x 5"	3.16	10	-	31.6
—	590-055	3" x 5-1/2"	3.48	10	-	34.8
570-060	—	3" x 6"	3.79	10	-	37.9
570-080	—	3" x 8"	5.06	5	-	25.3
570-100	590-100	3" x 10"	6.32	5	-	31.6
570-120	590-120	3" x 12"	7.50	5	-	75.0

NIPPLES

STANDARD WELDED STEEL



4"



Galvanized Part No.	Black Part No.	Description	Weight Aprox. (Lbs.)	Inner Box	Master Ctn.	Inner/Master Wt.(Lbs.)
571-001	#N/A	4" x Close	2.59	10	-	25.9
571-040	#N/A	4" x 4"	3.60	6	-	21.6
571-050	#N/A	4" x 5"	4.50	6	-	27.0
571-060	#N/A	4" x 6"	5.40	5	-	27.0
571-080	#N/A	4" x 8"	7.20	3	-	21.6
571-100	#N/A	4" x 10"	9.00	3	-	27.0
571-120	#N/A	4" x 12"	10.80	3	-	32.4

TUBE & PIPE

METAL FITTINGS & NIPPLES

PLASTIC FITTINGS

VALVES

FILTER-DRIERS & STRAINERS



PRE-CUT PIPE

STANDARD WELDED STEEL

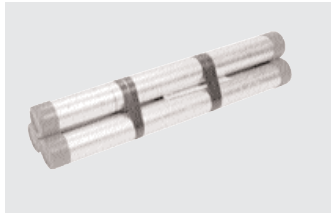
**3/8"**

Galvanized Part No.	Black Part No.	Description	Weight Approx. (Lbs.)	Inner Box	Master Ctn.	Inner/Master Wt.(Lbs.)
562-180	582-180	3/8" x 18"	0.85	5	-	4.2
562-240	582-240	3/8" x 24"	1.13	5	-	5.6
562-300	582-300	3/8" x 30"	1.41	5	-	7.1
562-360	582-360	3/8" x 36"	1.69	5	-	8.5
562-480	582-480	3/8" x 48"	2.26	5	-	11.3
562-600	582-600	3/8" x 60"	2.82	5	-	14.1

**1/2"**

Galvanized Part No.	Black Part No.	Description	Weight Approx. (Lbs.)	Inner Box	Master Ctn.	Inner/Master Wt.(Lbs.)
563-180	583-180	1/2" x 18"	1.28	5	-	6.4
563-240	583-240	1/2" x 24"	1.71	5	-	8.5
563-300	583-300	1/2" x 30"	2.13	5	-	10.7
563-360	583-360	1/2" x 36"	2.56	5	-	12.8
563-480	583-480	1/2" x 48"	3.41	5	-	17.1
563-600	583-600	1/2" x 60"	4.27	5	-	21.3
563-720	583-720	1/2" x 72"	5.12	5	-	25.6

3/4"

Galvanized Part No.	Black Part No.	Description	Weight Approx. (Lbs.)	Inner Box	Master Ctn.	Inner/Master Wt.(Lbs.)
564-180	584-180	3/4" x 18"	1.70	5	-	8.5
564-240	584-240	3/4" x 24"	2.27	5	-	11.4
564-300	584-300	3/4" x 30"	2.84	5	-	14.2
564-360	584-360	3/4" x 36"	3.41	5	-	17.0
564-480	584-480	3/4" x 48"	4.54	5	-	22.7
564-600	584-600	3/4" x 60"	5.68	5	-	28.4
564-720	584-720	3/4" x 72"	6.81	5	-	34.1

1"

Galvanized Part No.	Black Part No.	Description	Weight Approx. (Lbs.)	Inner Box	Master Ctn.	Inner/Master Wt.(Lbs.)
565-180	585-180	1" x 18"	2.52	3	-	7.6
565-240	585-240	1" x 24"	3.36	3	-	10.1
565-300	585-300	1" x 30"	4.20	3	-	12.6
565-360	585-360	1" x 36"	5.04	3	-	15.1
565-480	585-480	1" x 48"	6.72	3	-	20.2
565-600	585-600	1" x 60"	8.40	3	-	25.2
565-720	585-720	1" x 72"	10.08	3	-	30.2

Cut Pipe in
2-1/2", 3" & 4"
available upon request

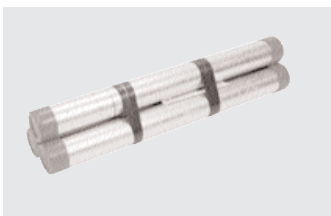

1-1/4"

Galvanized Part No.	Black Part No.	Description	Weight Approx. (Lbs.)	Inner Box	Master Ctn.	Inner/Master Wt.(Lbs.)
566-180	586-180	1-1/4" x 18"	3.42	3	-	10.3
566-240	586-240	1-1/4" x 24"	4.55	3	-	13.7
566-300	586-300	1-1/4" x 30"	5.69	3	-	17.1
566-360	586-360	1-1/4" x 36"	6.83	3	-	20.5
566-480	586-480	1-1/4" x 48"	9.11	3	-	27.3
566-600	586-600	1-1/4" x 60"	11.39	3	-	34.2
566-720	586-720	1-1/4" x 72"	13.67	3	-	41.0



1-1/2"

Galvanized Part No.	Black Part No.	Description	Weight Approx. (Lbs.)	Inner Box	Master Ctn.	Inner/Master Wt.(Lbs.)
567-180	587-180	1-1/2" x 18"	4.08	3	-	12.2
567-240	587-240	1-1/2" x 24"	5.44	3	-	16.3
567-300	587-300	1-1/2" x 30"	6.80	3	-	20.4
567-360	587-360	1-1/2" x 36"	8.16	3	-	24.5
567-480	587-480	1-1/2" x 48"	10.88	3	-	32.7
567-600	587-600	1-1/2" x 60"	13.60	3	-	40.8
567-720	587-720	1-1/2" x 72"	16.33	3	-	49.0

2"

Galvanized Part No.	Black Part No.	Description	Weight Approx. (Lbs.)	Inner Box	Master Ctn.	Inner/Master Wt.(Lbs.)
568-180	588-180	2" x 18"	5.48	3	-	16.4
568-240	588-240	2" x 24"	7.31	2	-	14.6
568-300	588-300	2" x 30"	9.14	2	-	18.3
568-360	588-360	2" x 36"	10.97	2	-	21.9
568-480	588-480	2" x 48"	14.62	2	-	29.2
568-600	588-600	2" x 60"	18.28	2	-	36.6

Cut Pipe in
2-1/2", 3" & 4"
available upon request



PIPE NIPPLE ASSORTMENTS

STANDARD WELDED STEEL



STANDARD PIPE NIPPLE ASSORTMENTS

Stock Code Galv	Stock Code Black	SIZE	TOTAL PIECES	CLOSE	1-1/2"	2"	2-1/2"	3"	3-1/2"	4"	4-1/2"	5"	5-1/2"	6"	APROX. WEIGHT LBS.
11800	21800	1/8"	100	20	10	15	10	10	5	10	5	5	5	5	11
11801	21801	1/4"	100	20	10	15	10	10	5	10	5	5	5	5	11
11802	21802	3/8"	100	20	10	15	10	10	5	10	5	5	5	5	12
11803	21803	1/2"	100	20	10	15	10	10	5	10	5	5	5	5	18
11804	21804	3/4"	100	15	-	20	20	10	5	10	5	5	5	5	24
11805	21805	1"	75	15	-	12	5	5	3	12	3	5	3	5	28



SPECIAL "6" PIPE NIPPLE ASSORTMENTS

Stock Code Galv	Stock Code Black	SIZE	TOTAL PIECES	CLOSE	1-1/2"	2"	2-1/2"	3"	3-1/2"	4"	4-1/2"	5"	5-1/2"	6"	APROX. WEIGHT LBS.
11700	21700	1/8"	66	6	6	6	6	6	6	6	6	6	6	6	5
11701	21701	1/4"	66	6	6	6	6	6	6	6	6	6	6	6	8
11702	21702	3/8"	66	6	6	6	6	6	6	6	6	6	6	6	12
11703	21703	1/2"	66	6	6	6	6	6	6	6	6	6	6	6	14
11704	21704	3/4"	66	6	6	6	6	6	6	6	6	6	6	6	19
11705	21705	1"	60	6	-	6	6	6	6	6	6	6	6	6	27
11706	21706	1-1/4"	60	6	-	6	6	6	6	6	6	6	6	6	37
11707	21707	1-1/2"	60	6	-	6	6	6	6	6	6	6	6	6	46
11708	21708	2"	54	6	-	-	6	6	6	6	6	6	6	6	59



SPECIAL "25" PIPE NIPPLE ASSORTMENTS

Stock Code Galv	Stock Code Black	SIZE	TOTAL PIECES	CLOSE	1-1/2"	2"	2-1/2"	3"	3-1/2"	4"	4-1/2"	5"	5-1/2"	6"	APROX. WEIGHT LBS.
11600	21600	1/8"	25	4	3	3	3	2	2	2	1	2	1	2	1
11601	21601	1/4"	25	4	3	3	3	2	2	2	1	2	1	2	2.5
11602	21602	3/8"	25	4	3	3	3	2	2	2	1	2	1	2	3
11603	21603	1/2"	25	4	3	3	3	2	2	2	1	2	1	2	5
11604	21604	3/4"	25	6	-	4	3	2	2	2	1	2	1	2	6
11605	21605	1"	25	5	-	5	3	2	2	2	1	2	1	2	9
11606	21606	1-1/4"	25	5	-	5	3	2	2	2	1	2	1	2	12
11607	21607	1-1/2"	25	5	-	5	3	2	2	2	1	2	1	2	15
11608	21608	2"	25	5	-	-	4	3	2	3	2	2	2	2	24

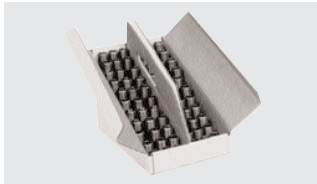

SLANT-BOX PIPE NIPPLE ASSORTMENTS

Stock Code Galv	Stock Code Black	SIZE	TOTAL PIECES	CLOSE	1-1/2"	2"	2-1/2"	3"	3-1/2"	4"	4-1/2"	5"	5-1/2"	6"	APROX. WEIGHT LBS.
12000	22000	1/2"	66	6	6	6	6	6	6	6	6	6	6	6	15
12001	22001	3/4"	66	6	6	6	6	6	6	6	6	6	6	6	20
12002	22002	1"	60	6	-	6	6	6	6	6	6	6	6	6	22

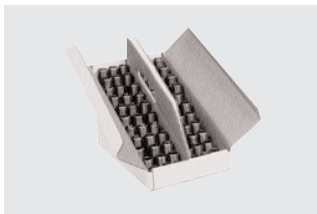

SINGLE PIPE NIPPLE ASSORTMENTS

Stock Code Galv	Stock Code Black	SIZE	TOTAL PIECES	CLOSE	1-1/2"	2"	2-1/2"	3"	3-1/2"	4"	4-1/2"	5"	5-1/2"	6"	APROX. WEIGHT LBS.
11500	21500	1/8"	11	1	1	1	1	1	1	1	1	1	1	1	1
11501	21501	1/4"	11	1	1	1	1	1	1	1	1	1	1	1	1-1/2
11502	21502	3/8"	11	1	1	1	1	1	1	1	1	1	1	1	2
11503	21503	1/2"	11	1	1	1	1	1	1	1	1	1	1	1	2-1/2
11504	21504	3/4"	11	1	1	1	1	1	1	1	1	1	1	1	3-1/2
11505	21505	1"	10	1	-	1	1	1	1	1	1	1	1	1	5
11506	21506	1-1/4"	10	1	-	1	1	1	1	1	1	1	1	1	7
11507	21507	1-1/2"	10	1	-	1	1	1	1	1	1	1	1	1	8
11508	21508	2"	9	1	-	-	1	1	1	1	1	1	1	1	9

NIPPLES

STANDARD SEAMLESS STEEL

TUBE & PIPE

METAL FITTINGS & NIPPLES

PLASTIC FITTINGS

VALVES

FILTER-DRIERS & STRAINERS



1/8"

Black Part No.	Description	Weight Approx. (Lbs.)	Inner Box	Master Ctn.	Master Wt. (Lbs.)
80100	1/8" x Close	0.0176	25	100	2
80101	1/8" x 1-1/2"	0.0309	25	100	3
80102	1/8" x 2"	0.0419	25	100	4
80103	1/8" x 2-1/2"	0.0661	25	100	7
80104	1/8" x 3"	0.0617	25	100	6
80105	1/8" x 3-1/2"	0.0728	25	100	7
80106	1/8" x 4"	0.0838	25	100	8
80107	1/8" x 4-1/2"	0.0926	25	100	9
80108	1/8" x 5"	0.1036	25	100	10
80109	1/8" x 5-1/2"	0.1146	25	100	11
80110	1/8" x 6"	0.1235	25	100	12
80111	1/8" x 7"	0.1455	100	-	15
80112	1/8" x 8"	0.1653	100	-	17
80113	1/8" x 9"	0.1874	100	-	19
80114	1/8" x 10"	0.2072	100	-	21
80115	1/8" x 11"	0.2271	100	-	23
80116	1/8" x 12"	0.2491	100	-	25

1/4"

Black Part No.	Description	Weight Approx. (Lbs.)	Inner Box	Master Ctn.	Master Wt. (Lbs.)
80200	1/4" x Close	0.0309	25	100	3
80201	1/4" x 1-1/2"	0.0529	25	100	5
80202	1/4" x 2"	0.0705	25	100	7
80203	1/4" x 2-1/2"	0.0882	25	100	9
80204	1/4" x 3"	0.1058	25	100	11
80205	1/4" x 3-1/2"	0.1235	25	100	12
80206	1/4" x 4"	0.1411	25	100	14
80207	1/4" x 4-1/2"	0.1587	25	100	16
80208	1/4" x 5"	0.1764	25	100	18
80209	1/4" x 5-1/2"	0.1940	25	100	19
80210	1/4" x 6"	0.2116	25	100	21
80211	1/4" x 7"	0.2469	100	-	25
80212	1/4" x 8"	0.2822	100	-	28
80213	1/4" x 9"	0.3175	100	-	32
80214	1/4" x 10"	0.3527	100	-	35
80215	1/4" x 11"	0.3880	100	-	39
80216	1/4" x 12"	0.4233	100	-	42

3/8"

Black Part No.	Description	Weight Approx. (Lbs.)	Inner Box	Master Ctn.	Master Wt. (Lbs.)
80300	3/8" x Close	0.0463	25	100	5
80301	3/8" x 1-1/2"	0.0705	25	100	7
80302	3/8" x 2"	0.0948	25	100	9
80303	3/8" x 2-1/2"	0.1168	25	100	12
80304	3/8" x 3"	0.1411	25	100	14
80305	3/8" x 3-1/2"	0.1653	25	100	17
80306	3/8" x 4"	0.1874	25	100	19
80307	3/8" x 4-1/2"	0.2116	25	100	21
80308	3/8" x 5"	0.2359	25	100	24
80309	3/8" x 5-1/2"	0.2579	25	100	26
80310	3/8" x 6"	0.2822	25	100	28
80311	3/8" x 7"	0.3285	75	-	25
80312	3/8" x 8"	0.3770	75	-	28
80313	3/8" x 9"	0.4233	75	-	32
80314	3/8" x 10"	0.4696	75	-	35
80315	3/8" x 11"	0.5181	75	-	39
80316	3/8" x 12"	0.5644	75	-	42

GALVANIZED
Seamless & XH Seamless
Available upon request

BLACK IRON
Schedule 160 & XXH Seamless
Available upon request



NIPPLES

STANDARD SEAMLESS STEEL

TUBE & PIPE

METAL FITTINGS & NIPPLES

PLASTIC FITTINGS

VALVES

FILTER-DRIERS & STRAINERS



1/2"

Black Part No.	Description	Weight Approx. (Lbs.)	Inner Box	Master Ctn.	Master Wt. (Lbs.)
80400	1/2" x Close	0.0794	25	100	8
80401	1/2" x 1-1/2"	0.1058	25	100	11
80402	1/2" x 2"	0.1433	25	100	14
80403	1/2" x 2-1/2"	0.1786	25	100	18
80404	1/2" x 3"	0.2138	25	100	21
80405	1/2" x 3-1/2"	0.2491	25	100	25
80406	1/2" x 4"	0.2844	25	100	28
80407	1/2" x 4-1/2"	0.3197	25	100	32
80408	1/2" x 5"	0.3549	25	100	35
80409	1/2" x 5-1/2"	0.3902	25	100	39
80410	1/2" x 6"	0.4277	25	100	43
80411	1/2" x 7"	0.4982	25	-	12
80412	1/2" x 8"	0.5688	25	-	14
80413	1/2" x 9"	0.6393	25	-	16
80414	1/2" x 10"	0.7121	25	-	18
80415	1/2" x 11"	0.7826	25	-	20
80416	1/2" x 12"	0.8532	25	-	21

3/4"

Black Part No.	Description	Weight Approx. (Lbs.)	Inner Box	Master Ctn.	Master Wt. (Lbs.)
80500	3/4" x Close	0.1301	25	100	13
80501	3/4" x 1-1/2"	0.1411	25	100	14
80502	3/4" x 2"	0.1896	25	100	19
80503	3/4" x 2-1/2"	0.2359	25	100	24
80504	3/4" x 3"	0.2844	25	100	28
80505	3/4" x 3-1/2"	0.3307	25	100	33
80506	3/4" x 4"	0.3792	25	100	38
80507	3/4" x 4-1/2"	0.4255	25	100	43
80508	3/4" x 5"	0.4740	25	100	47
80509	3/4" x 5-1/2"	0.5203	25	100	52
80510	3/4" x 6"	0.5688	25	100	57
80511	3/4" x 7"	0.6614	25	-	17
80512	3/4" x 8"	0.7562	25	-	19
80513	3/4" x 9"	0.8510	25	-	21
80514	3/4" x 10"	0.9458	25	-	24
80515	3/4" x 11"	1.0406	25	-	26
80516	3/4" x 12"	1.1354	25	-	28

1"

Black Part No.	Description	Weight Approx. (Lbs.)	Inner Box	Master Ctn.	Master Wt. (Lbs.)
80600	1" x Close	0.2094	25	100	5
80602	1" x 2"	0.2800	25	100	7
80603	1" x 2-1/2"	0.3505	25	100	9
80604	1" x 3"	0.4189	25	100	10
80605	1" x 3-1/2"	0.4894	25	100	12
80606	1" x 4"	0.5600	25	100	14
80607	1" x 4-1/2"	0.6305	25	-	16
80608	1" x 5"	0.6989	25	-	17
80609	1" x 5-1/2"	0.7694	25	-	19
80610	1" x 6"	0.8400	25	-	21
80611	1" x 7"	0.9789	25	-	24
80612	1" x 8"	1.1199	25	-	28
80613	1" x 9"	1.2588	25	-	31
80614	1" x 10"	1.3999	25	-	35
80615	1" x 11"	1.5388	25	-	38
80616	1" x 12"	1.6799	25	-	42

GALVANIZED
Seamless & XH Seamless
Available upon request

BLACK IRON
Schedule 160 & XXH Seamless
Available upon request



NIPPLES

STANDARD SEAMLESS STEEL



1-1/2"

Black Part No.	Description	Weight (Lbs.)	Inner Box
80800	1-1/2" x Close	0.3968	25
80802	1-1/2" x 2"	0.4542	25
80803	1-1/2" x 2-1/2"	0.5666	25
80804	1-1/2" x 3"	0.6812	25
80805	1-1/2" x 3-1/2"	0.7937	25
80806	1-1/2" x 4"	0.9061	25
80807	1-1/2" x 4-1/2"	1.0207	25
80808	1-1/2" x 5"	1.1332	25
80809	1-1/2" x 5-1/2"	1.2478	25
80810	1-1/2" x 6"	1.3603	25
80811	1-1/2" x 7"	1.5873	10
80812	1-1/2" x 8"	1.8144	10
80813	1-1/2" x 9"	2.0415	10
80814	1-1/2" x 10"	2.2686	10
80815	1-1/2" x 11"	2.4934	10
80816	1-1/2" x 12"	2.7205	10

2"

Black Part No.	Description	Weight (Lbs.)	Inner Box
80900	2" x Close	0.6085	25
80903	2" x 2-1/2"	0.7606	25
80904	2" x 3"	0.9127	25
80905	2" x 3-1/2"	1.0670	25
80906	2" x 4"	1.2192	25
80907	2" x 4-1/2"	1.3713	25
80908	2" x 5"	1.5234	25
80909	2" x 5-1/2"	1.6755	25
80910	2" x 6"	1.8276	25
80911	2" x 7"	2.1319	10
80912	2" x 8"	2.4361	10
80913	2" x 9"	2.7403	10
80914	2" x 10"	3.0468	10
80915	2" x 11"	3.3510	10
80916	2" x 12"	3.6553	10

2-1/2"

Black Part No.	Description	Weight (Lbs.)	Inner Box
81000	2-1/2" x Close	1.2081	10
81004	2-1/2" x 3"	1.4506	10
81005	2-1/2" x 3-1/2"	1.6909	10
81006	2-1/2" x 4"	1.9335	10
81007	2-1/2" x 4-1/2"	2.1738	10
81008	2-1/2" x 5"	2.4163	10
81009	2-1/2" x 5-1/2"	2.6566	10
81010	2-1/2" x 6"	2.8991	10
81011	2-1/2" x 7"	3.3819	10
81012	2-1/2" x 8"	3.8647	10
81013	2-1/2" x 9"	4.3497	10
81014	2-1/2" x 10"	4.8325	5
81015	2-1/2" x 11"	5.3153	5
81016	2-1/2" x 12"	5.7982	5

GALVANIZED
Seamless & XH Seamless
Available upon request

BLACK IRON
Schedule 160 & XXH Seamless
Available upon request

TUBE & PIPE

METAL FITTINGS & NIPPLES

PLASTIC FITTINGS

VALVES

FILTER-DRIERS & STRAINERS



NIPPLES

STANDARD SEAMLESS STEEL



3"

Black Part No.	Description	Weight (Lbs.)	Inner Box
81100	3" x Close	1.6601	10
81104	3" x 3"	1.8960	10
81105	3" x 3-1/2"	2.2134	10
81106	3" x 4"	2.5287	10
81107	3" x 4-1/2"	2.8440	10
81108	3" x 5"	3.1614	10
81109	3" x 5-1/2"	3.4767	10
81110	3" x 6"	3.7920	10
81111	3" x 7"	4.4247	5
81112	3" x 8"	5.0574	5
81113	3" x 9"	5.6901	5
81114	3" x 10"	6.3207	5
81115	3" x 11"	6.9534	5
81116	3" x 12"	7.5861	5

4"

Black Part No.	Description	Weight (Lbs.)	Inner Box
81200	4" x Close	2.5860	10
81205	4" x 3-1/2"	3.1482	6
81206	4" x 4"	3.6001	6
81208	4" x 5"	4.4996	6
81209	4" x 5-1/2"	4.9494	5
81210	4" x 6"	5.3991	5
81211	4" x 7"	6.2986	3
81212	4" x 8"	7.1981	3
81213	4" x 9"	8.0976	3
81214	4" x 10"	8.9971	3
81215	4" x 11"	9.8966	3
81216	4" x 12"	10.7982	3

6"

Black Part No.	Description	Weight (Lbs.)	Inner Box
81400	6" x Close	4.9450	2
81406	6" x 4"	6.3295	2
81407	6" x 4-1/2"	7.1209	2
81408	6" x 5"	7.9124	2
81409	6" x 5-1/2"	8.7016	2
81410	6" x 6"	9.4931	2
81411	6" x 7"	11.0760	1
81412	6" x 8"	12.6589	1
81413	6" x 9"	14.2397	1
81414	6" x 10"	15.8226	1
81415	6" x 11"	17.4055	1
81416	6" x 12"	18.9884	1

GALVANIZED
Seamless & XH Seamless
Available upon request

BLACK IRON
Schedule 160 & XXH Seamless
Available upon request



1/8"

Black Part No.	Description	Weight Approx. (Lbs.)	Inner Box	Master Ctn.	Master Wt. (Lbs.)
90100	1/8" x Close	0.0220	25	100	2
90101	1/8" x 1-1/2"	0.0397	25	100	4
90102	1/8" x 2"	0.0529	25	100	5
90103	1/8" x 2-1/2"	0.0661	25	100	7
90104	1/8" x 3"	0.0794	25	100	8
90105	1/8" x 3-1/2"	0.0926	25	100	9
90106	1/8" x 4"	0.1058	25	100	11
90107	1/8" x 4-1/2"	0.1190	25	100	12
90108	1/8" x 5"	0.1323	25	100	13
90109	1/8" x 5-1/2"	0.1455	25	100	15
90110	1/8" x 6"	0.1587	25	100	16
90111	1/8" x 7"	0.1852	100	-	19
90112	1/8" x 8"	0.2094	100	-	21
90113	1/8" x 9"	0.2359	100	-	24
90114	1/8" x 10"	0.2624	100	-	26
90115	1/8" x 11"	0.2888	100	-	29
90116	1/8" x 12"	0.3153	100	-	32

1/4"

Black Part No.	Description	Weight Approx. (Lbs.)	Inner Box	Master Ctn.	Master Wt. (Lbs.)
90200	1/4" x Close	0.0397	25	100	4
90201	1/4" x 1-1/2"	0.0661	25	100	7
90202	1/4" x 2"	0.0904	25	100	9
90203	1/4" x 2-1/2"	0.1124	25	100	11
90204	1/4" x 3"	0.1345	25	100	13
90205	1/4" x 3-1/2"	0.1565	25	100	16
90206	1/4" x 4"	0.1786	25	100	18
90207	1/4" x 4-1/2"	0.2006	25	100	20
90208	1/4" x 5"	0.2249	25	100	22
90209	1/4" x 5-1/2"	0.2469	25	100	25
90210	1/4" x 6"	0.2690	25	100	27
90211	1/4" x 7"	0.3131	100	-	31
90212	1/4" x 8"	0.3594	100	-	36
90213	1/4" x 9"	0.4034	100	-	40
90214	1/4" x 10"	0.4475	100	-	45
90215	1/4" x 11"	0.4916	100	-	49
90216	1/4" x 12"	0.5379	100	-	54

3/8"

Black Part No.	Description	Weight Approx. (Lbs.)	Inner Box	Master Ctn.	Master Wt. (Lbs.)
90300	3/8" x Close	0.0617	25	100	6
90301	3/8" x 1-1/2"	0.0926	25	100	9
90302	3/8" x 2"	0.1235	25	100	12
90303	3/8" x 2-1/2"	0.1543	25	100	15
90304	3/8" x 3"	0.1852	25	100	19
90305	3/8" x 3-1/2"	0.2161	25	100	22
90306	3/8" x 4"	0.2469	25	100	25
90307	3/8" x 4-1/2"	0.2778	25	100	28
90308	3/8" x 5"	0.3086	25	100	31
90309	3/8" x 5-1/2"	0.3395	25	100	34
90310	3/8" x 6"	0.3704	25	100	37
90311	3/8" x 7"	0.4321	75	-	32
90312	3/8" x 8"	0.4916	75	-	37
90313	3/8" x 9"	0.5534	75	-	42
90314	3/8" x 10"	0.6151	75	-	46
90315	3/8" x 11"	0.6768	75	-	51
90316	3/8" x 12"	0.7385	75	-	55

GALVANIZED
Seamless & XH Seamless
Available upon request

BLACK IRON
Schedule 160 & XXH Seamless
Available upon request



NIPPLES

XH SEAMLESS STEEL



1/2"

Black Part No.	Description	Weight (Lbs.)	Inner Box
90400	1/2" x Close	0.1014	25
90401	1/2" x 1-1/2"	0.1367	25
90402	1/2" x 2"	0.1808	25
90403	1/2" x 2-1/2"	0.2271	25
90404	1/2" x 3"	0.2712	25
90405	1/2" x 3-1/2"	0.3175	25
90406	1/2" x 4"	0.3638	25
90407	1/2" x 4-1/2"	0.4079	25
90408	1/2" x 5"	0.4542	25
90409	1/2" x 5-1/2"	0.4982	25
90410	1/2" x 6"	0.5445	25
90411	1/2" x 7"	0.6349	25
90412	1/2" x 8"	0.7253	25
90413	1/2" x 9"	0.8157	25
90414	1/2" x 10"	0.9061	25
90415	1/2" x 11"	0.9987	25
90416	1/2" x 12"	1.0891	25

3/4"

Black Part No.	Description	Weight (Lbs.)	Inner Box
90500	3/4" x Close	0.1698	25
90501	3/4" x 1-1/2"	0.1852	25
90502	3/4" x 2"	0.2469	25
90503	3/4" x 2-1/2"	0.3086	25
90504	3/4" x 3"	0.3704	25
90505	3/4" x 3-1/2"	0.4321	25
90506	3/4" x 4"	0.4916	25
90507	3/4" x 4-1/2"	0.5534	25
90508	3/4" x 5"	0.6151	25
90509	3/4" x 5-1/2"	0.6768	25
90510	3/4" x 6"	0.7385	25
90511	3/4" x 7"	0.8620	25
90512	3/4" x 8"	0.9855	25
90513	3/4" x 9"	1.1089	25
90514	3/4" x 10"	1.2324	25
90515	3/4" x 11"	1.3558	25
90516	3/4" x 12"	1.4771	25

1"

Black Part No.	Description	Weight (Lbs.)	Inner Box
90600	1" x Close	0.2712	25
90602	1" x 2"	0.3638	25
90603	1" x 2-1/2"	0.4542	25
90604	1" x 3"	0.5445	25
90605	1" x 3-1/2"	0.6349	25
90606	1" x 4"	0.7253	25
90607	1" x 4-1/2"	0.8157	25
90608	1" x 5"	0.9061	25
90609	1" x 5-1/2"	0.9987	25
90610	1" x 6"	1.0891	25
90611	1" x 7"	1.2699	25
90612	1" x 8"	1.4506	25
90613	1" x 9"	1.6336	25
90614	1" x 10"	1.8144	25
90615	1" x 11"	1.9952	25
90616	1" x 12"	2.1760	25

GALVANIZED
Seamless & XH Seamless
Available upon request

BLACK IRON
Schedule 160 & XXH Seamless
Available upon request



1-1/4"

Black Part No.	Description	Weight (Lbs.)	Inner Box
90700	1-1/4" x Close	0.4057	25
90702	1-1/4" x 2"	0.5004	25
90703	1-1/4" x 2-1/2"	0.6261	25
90704	1-1/4" x 3"	0.7518	25
90705	1-1/4" x 3-1/2"	0.8752	25
90706	1-1/4" x 4"	1.0009	25
90707	1-1/4" x 4-1/2"	1.1266	25
90708	1-1/4" x 5"	1.2522	25
90709	1-1/4" x 5-1/2"	1.3757	25
90710	1-1/4" x 6"	1.5013	25
90711	1-1/4" x 7"	1.7527	25
90712	1-1/4" x 8"	2.0018	25
90713	1-1/4" x 9"	2.2531	25
90714	1-1/4" x 10"	2.5022	25
90715	1-1/4" x 11"	2.7536	10
90716	1-1/4" x 12"	3.0027	10

1-1/2"

Black Part No.	Description	Weight (Lbs.)	Inner Box
90800	1-1/2" x Close	0.5291	25
90802	1-1/2" x 2"	0.6063	25
90803	1-1/2" x 2-1/2"	0.7562	25
90804	1-1/2" x 3"	0.9083	25
90805	1-1/2" x 3-1/2"	1.0604	25
90806	1-1/2" x 4"	1.2125	25
90807	1-1/2" x 4-1/2"	1.3625	25
90808	1-1/2" x 5"	1.5146	25
90809	1-1/2" x 5 1/2"	1.6667	25
90810	1-1/2" x 6"	1.8166	25
90811	1-1/2" x 7"	2.1208	10
90812	1-1/2" x 8"	2.4229	10
90813	1-1/2" x 9"	2.7271	10
90814	1-1/2" x 10"	3.0292	10
90815	1-1/2" x 11"	3.3312	10
90816	1-1/2" x 12"	3.6354	10

2"

Black Part No.	Description	Weight (Lbs.)	Inner Box
90900	2" x Close	0.8378	25
90903	2" x 2-1/2"	1.0472	25
90904	2" x 3"	1.2566	25
90905	2" x 3-1/2"	1.4661	25
90906	2" x 4"	1.6755	25
90907	2" x 4-1/2"	1.8850	25
90908	2" x 5"	2.0944	25
90909	2" x 5-1/2"	2.3038	25
90910	2" x 6"	2.5133	25
90911	2" x 7"	2.9321	10
90912	2" x 8"	3.3510	10
90913	2" x 9"	3.7699	10
90914	2" x 10"	4.1888	10
90915	2" x 11"	4.6077	10
90916	2" x 12"	5.0265	10

GALVANIZED
Seamless & XH Seamless
Available upon request

BLACK IRON
Schedule 160 & XXH Seamless
Available upon request

2-1/2"

Black Part No.	Description	Weight (Lbs.)	Inner Box
91000	2-1/2" x Close	1.5961	10
91004	2-1/2" x 3"	1.9158	10
91005	2-1/2" x 3-1/2"	2.2355	10





2-1/2" continued

Black Part No.	Description	Weight (Lbs.)	Inner Box
91006	2-1/2" x 4"	2.5552	10
91007	2-1/2" x 4-1/2"	2.8748	10
91008	2-1/2" x 5"	3.1945	10
91009	2-1/2" x 5-1/2"	3.5142	10
91010	2-1/2" x 6"	3.8338	10
91011	2-1/2" x 7"	4.4710	10
91012	2-1/2" x 8"	5.1103	10
91013	2-1/2" x 9"	5.7497	10
91014	2-1/2" x 10"	6.3890	5
91015	2-1/2" x 11"	7.0283	5
91016	2-1/2" x 12"	7.6655	5

3"

Black Part No.	Description	Weight (Lbs.)	Inner Box
91100	3" x Close	2.2443	10
91104	3" x 3"	2.5640	10
91105	3" x 3-1/2"	2.9917	10
91106	3" x 4"	3.4194	10
91107	3" x 4-1/2"	3.8471	10
91108	3" x 5"	4.2748	10
91109	3" x 5-1/2"	4.7025	10
91110	3" x 6"	5.1302	10
91111	3" x 7"	5.9856	5
91112	3" x 8"	6.8387	5
91113	3" x 9"	7.6941	5
91114	3" x 10"	8.5495	5
91115	3" x 11"	9.4049	5
91116	3" x 12"	10.2603	5

4"

Black Part No.	Description	Weight (Lbs.)	Inner Box
91200	4" x Close	3.5935	10
91205	4" x 3-1/2"	4.3740	6
91206	4" x 4"	4.9979	6
91207	4" x 4-1/2"	5.6240	6
91208	4" x 5"	6.2479	6
91209	4" x 5-1/2"	6.8740	5
91210	4" x 6"	7.4979	5
91211	4" x 7"	8.7479	3
91212	4" x 8"	9.9980	3
91213	4" x 9"	11.2480	3
91214	4" x 10"	12.4980	3
91215	4" x 11"	13.7458	3
91216	4" x 12"	14.9958	3

6"

Black Part No.	Description	Weight (Lbs.)	Inner Box
91400	6" x Close	7.4472	2
91406	6" x 4"	9.5328	2
91407	6" x 4-1/2"	10.7233	2
91408	6" x 5"	11.9138	2
91409	6" x 5-1/2"	13.1065	2
91410	6" x 6"	14.2970	2
91411	6" x 7"	16.6802	1
91412	6" x 8"	19.0634	1
91413	6" x 9"	21.4466	1
91414	6" x 10"	23.8298	1
91415	6" x 11"	26.2130	1
91416	6" x 12"	28.5962	1

GALVANIZED
Seamless & XH Seamless
Available upon request

BLACK IRON
Schedule 160 & XXH Seamless
Available upon request



Brass Fittings & Nipples

Mueller's Red and Yellow Brass Fittings and Nipples are carefully produced and threaded to industry specifications to provide a secure and trusted fit. Though these fittings and nipples are used primarily for water in commercial plumbing and OEM applications, they can also be used in oil, gas and steam applications. They are sought after for repair and maintenance because of the durability and resistance to corrosion. All of our red and yellow brass fittings and nipples are 100% inspected and quality tested.

- Class 125lb Red Brass Fittings
- Red Brass Pipe meets ASTM B43-96 standard and ASTM B16.15 Dimensional Specifications
- Red Brass Material specification is to ASTM B62
- Red Brass Fitting and Nipple threads are to specification ANSI B1.20.1



90° ELBOW

RED BRASS



Part Number	UPC-A (032888)	Size	Inner/Master Carton Qty.	Master Weight (lbs.)
450-000	401009	1/8"	5/25	38
450-001	401013	1/4"	5/25	32
450-002	401020	3/8"	5/25	30
450-003	401037	1/2"	5/25	46
450-004	401044	3/4"	5/25	27
550-005	401051	1"	5/25	30
450-006	401068	1-1/4"	1/50	44
550-007	401075	1-1/2"	1/35	44
450-008	401082	2"	1/20	40

90° ELBOW • STREET

RED BRASS



Part Number	UPC-A (032888)	Size	Inner/Master Carton Qty.	Master Weight (lbs.)
452-000	401009	1/8"	5/25	38
452-001	401013	1/4"	5/25	32
452-002	401020	3/8"	5/25	30
452-003	401037	1/2"	5/25	46
452-004	401044	3/4"	5/25	27
552-005	401051	1"	5/25	30
452-006	401068	1-1/4"	1/50	44
452-007	401075	1-1/2"	1/35	44
452-008	401082	2"	1/20	40

90° ELBOW • REDUCING

RED BRASS



Part Number	UPC-A (032888)	Size	Inner/Master Carton Qty.	Master Weight (lbs.)
450-020	401105	3/8" x 1/8"	5/25	29
450-021	401112	3/8" x 1/4"	5/25	27
450-031	401099	1/2" x 1/4"	5/25	12
450-032	401129	1/2" x 3/8"	5/25	17
450-041	401150	3/4" x 1/4"	5/25	20
450-043	401136	3/4" x 1/2"	5/25	23
450-053	401167	1" x 1/2"	5/25	25
450-054	401143	1" x 3/4"	5/25	28
450-064	401174	1-1/4" x 3/4"	1/40	31
450-065	401181	1-1/4" x 1"	1/40	37
450-075	401198	1-1/2" x 1"	1/35	34
450-076	401372	1-1/2" x 1-1/4"	1/35	38
450-086	401389	2" x 1-1/4"	1/20	33
450-087	401396	2" x 1-1/2"	1/20	40

45° ELBOW

RED BRASS



Part Number	UPC-A (032888)	Size	Inner/Master Carton Qty.	Master Weight (lbs.)
451-000	401204	1/8"	5/25	40
451-001	401211	1/4"	5/25	30
451-002	401228	3/8"	5/25	33
451-003	401235	1/2"	5/25	40
451-004	401242	3/4"	5/25	24
451-005	401259	1"	5/25	28
451-006	401266	1-1/4"	1/50	35
451-007	401273	1-1/2"	1/40	42
451-008	401839	2"	1/25	39

45° ELBOW • STREET

RED BRASS



Part Number	UPC-A (032888)	Size	Inner/Master Carton Qty.	Master Weight (lbs.)
451-100	401846	1/8"	5/25	33
451-101	401853	1/4"	5/25	30
451-102	401860	3/8"	5/25	23
451-103	401877	1/2"	5/25	22
451-104	401884	3/4"	5/25	23
451-105	401891	1"	5/25	24
451-106	401990	1-1/4"	1/50	38
451-107	402195	1-1/2"	1/35	36
451-108	402560	2"	1/20	39

TEE

RED BRASS



Part Number	UPC-A (032888)	Size	Inner/Master Carton Qty.	Master Weight (lbs.)
453-000	401402	1/8"	5/25	26
453-001	401419	1/4"	5/25	43
453-002	401426	3/8"	5/25	43
453-003	401433	1/2"	5/25	22
453-004	401440	3/4"	5/25	24
553-005	401457	1"	5/25	25
453-006	401464	1-1/4"	1/35	38
553-007	401471	1-1/2"	1/25	37

TEE • REDUCING

RED BRASS



Part Number	UPC-A (032888)	Size	Inner/Master Carton Qty.	Master Weight (lbs.)
453-043	401495	3/4" x 1/2"	5/25	32
453-053	530539	1-1/2" x 1/2"	5/25	40
453-054	402317	1" x 3/4"	5/25	32

CROSS

RED BRASS



Part Number	UPC-A (032888)	Size	Inner/Master Carton Qty.	Master Weight (lbs.)
453-100	402324	1/8"	5/25	41
453-101	402331	1/4"	5/25	42
453-102	402348	3/8"	5/25	25
453-103	402355	1/2"	5/25	31
453-104	402362	3/4"	5/25	32
453-105	402379	1"	5/25	29
453-106	402386	1-1/4"	1/25	37
453-107	402393	1-1/2"	1/20	38
453-108	402515	2"	1/10	31

COUPLING

RED BRASS



Part Number	UPC-A (032888)	Size	Inner/Master Carton Qty.	Master Weight (lbs.)
454-000	401501	1/8"	5/25	32
454-001	401518	1/4"	5/25	48
454-002	401525	3/8"	5/25	42
454-003	401532	1/2"	5/25	37
454-004	401549	3/4"	5/25	21
454-005	401556	1"	5/25	33
454-006	401563	1-1/4"	1/75	46
454-007	401570	1-1/2"	1/50	40
454-008	401587	2"	1/30	37

TUBE & PIPE

METAL FITTINGS & NIPPLES

PLASTIC FITTINGS

VALVES

FILTER-DRIERS & STRAINERS



COUPLING • REDUCER

RED BRASS



Part Number	UPC-A (032888)	Size	Inner/Master Carton Qty.	Master Weight (lbs.)
454-010	401594	1/4" x 1/8"	5/25	44
454-020	401600	3/8" x 1/8"	5/25	31
454-021	401617	3/8" x 1/4"	5/25	31
454-031	401679	1/2" x 1/4"	5/25	30
454-032	401624	1/2" x 3/8"	5/25	33
454-041	403543	3/4" x 1/4"	5/25	14
454-042	401631	3/4" x 3/8"	5/25	17
454-043	401648	3/4" x 1/2"	5/25	19
454-052	403550	1" x 3/8"	5/25	19
454-053	401655	1" x 1/2"	5/25	25
454-054	401662	1" x 3/4"	5/25	27
454-064	401686	1-1/4" x 3/4"	1/90	44
454-065	401693	1-1/4" x 1"	1/80	45
454-073	403567	1-1/2" x 1/2"	1/75	42
454-074	403574	1-1/2" x 3/4"	1/75	45
454-075	402522	1-1/2" x 1"	1/65	45
454-076	402539	1-1/2" x 1-1/4"	1/60	45
454-084	403581	2" x 3/4"	1/30	27
454-085	403598	2" x 1"	1/30	42
454-086	402546	2" x 1-1/4"	1/30	32
454-087	402553	2" x 1-1/2"	1/30	32

BUSHING • HEX

RED BRASS



Part Number	UPC-A (032888)	Size	Inner/Master Carton Qty.	Master Weight (lbs.)
455-010	401709	1/4" x 1/8"	5/25	24
455-020	401716	3/8" x 1/8"	5/25	33
455-021	401723	3/8" x 1/4"	5/25	30
455-030	401792	1/2" x 1/8"	5/25	29
455-031	401785	1/2" x 1/4"	5/25	26
455-032	401730	1/2" x 3/8"	5/25	20
455-041	401822	3/4" x 1/4"	5/25	33
455-042	401747	3/4" x 3/8"	5/25	29
455-043	401754	3/4" x 1/2"	5/25	29
455-053	401761	1" x 1/2"	5/25	19
455-054	401778	1" x 3/4"	5/25	17
455-064	402577	1-1/4" x 3/4"	1/120	49
455-065	402584	1-1/4" x 1"	1/120	37
455-075	402591	1-1/2" x 1"	1/120	67
455-076	402713	1-1/2" x 1-1/4"	1/120	49
455-086	402720	2" x 1-1/4"	1/65	50
455-087	402737	2" x 1-1/2"	1/65	49

LOCKNUT

RED BRASS



Part Number	UPC-A (032888)	Size	Inner/Master Carton Qty.	Master Weight (lbs.)
456-002	560024	3/8"	2/25	28
456-003	402744	1/2"	5/25	28
456-004	402751	3/4"	5/25	41

CAP

RED BRASS



Part Number	UPC-A (032888)	Size	Inner/Master Carton Qty.	Master Weight (lbs.)
457-000	401907	1/8"	5/25	27
457-001	401914	1/4"	5/25	41
457-002	401921	3/8"	5/25	25
457-003	401938	1/2"	5/25	36
457-004	401945	3/4"	5/25	35
557-005	401952	1"	5/25	22
457-006	401969	1-1/4"	1/100	49
557-007	401976	1-1/2"	1/100	48
457-008	401983	2"	1/70	53

PLUG • SOLID

RED BRASS



Part Number	UPC-A (032888)	Size	Inner/Master Carton Qty.	Master Weight (lbs.)
458-000	402003	1/8"	5/25	14
458-001	402010	1/4"	5/25	26
458-002	402027	3/8"	5/25	45
458-003	402034	1/2"	5/25	42
458-004	402041	3/4"	5/25	46
558-005	402058	1"	5/25	28
458-006	402065	1-1/4"	5/140	85
558-007	402072	1-1/2"	5/120	97
458-008	402089	2"	5/100	146

PLUG • CORED

RED BRASS



Part Number	UPC-A (032888)	Size	Inner/Master Carton Qty.	Master Weight (lbs.)
458-093	402096	1/2"	5/25	33
458-094	402768	3/4"	5/25	32
458-095	402775	1"	5/25	17
458-096	402782	1-1/4"	5/140	43
458-097	402799	1-1/2"	1/120	49
458-098	402911	2"	1/100	71

UNION

RED BRASS



Part Number	UPC-A (032888)	Size	Inner/Master Carton Qty.	Master Weight (lbs.)
459-000	402102	1/8"	5/25	29
459-001	402119	1/4"	5/25	25
459-002	402126	3/8"	5/25	29
459-003	402133	1/2"	5/25	32
459-004	402140	3/4"	5/25	32
559-005	402157	1"	5/25	25
459-006	402164	1-1/4"	1/35	43
559-007	402171	1-1/2"	1/25	42
459-008	402188	2"	1/15	36

TUBE & PIPE

METAL FITTINGS & NIPPLES

PLASTIC FITTINGS

VALVES

FILTER-DRIERS & STRAINERS



1/8" NIPPLE**RED BRASS**

Part Number	UPC-A (032888)	Size	Inner/Master Carton Qty.	Master Weight (lbs.)
460-001	402201	1/8" x Close	5/25	1
460-015	402218	1/8" x 1-1/2"	5/25	1
460-020	402225	1/8" x 2"	5/25	1
460-025	402232	1/8" x 2-1/2"	5/25	1
460-030	402249	1/8" x 3"	5/25	2
460-035	402256	1/8" x 3-1/2"	5/25	2
460-040	402263	1/8" x 4"	5/25	2
460-045	402270	1/8" x 4-1/2"	5/25	2
460-050	402287	1/8" x 5"	5/25	3
460-055	402294	1/8" x 5-1/2"	5/25	3
460-060	402300	1/8" x 6"	5/25	3

1/4" NIPPLE**RED BRASS**

Part Number	UPC-A (032888)	Size	Inner/Master Carton Qty.	Master Weight (lbs.)
461-001	402409	1/4" x Close	5/25	1
461-015	402416	1/4" x 1-1/2"	5/25	2
461-020	402423	1/4" x 2"	5/25	2
461-025	402430	1/4" x 2-1/2"	5/25	2
461-030	402447	1/4" x 3"	5/25	3
461-035	402454	1/4" x 3-1/2"	5/25	3
461-040	402461	1/4" x 4"	5/25	4
461-045	402478	1/4" x 4-1/2"	5/25	4
461-050	402485	1/4" x 5"	5/25	5
461-055	402492	1/4" x 5-1/2"	5/25	5
461-060	402508	1/4" x 6"	5/25	5

3/8" NIPPLE**RED BRASS**

Part Number	UPC-A (032888)	Size	Inner/Master Carton Qty.	Master Weight (lbs.)
462-001	402607	3/8" x Close	5/25	1
462-015	402614	3/8" x 1-1/2"	5/25	2
462-020	402621	3/8" x 2"	5/25	3
462-025	402638	3/8" x 2-1/2"	5/25	3
462-030	402645	3/8" x 3"	5/25	4
462-035	402652	3/8" x 3-1/2"	5/25	4
462-040	402669	3/8" x 4"	5/25	5
462-045	402676	3/8" x 4-1/2"	5/25	6
462-050	402683	3/8" x 5"	5/25	6
462-055	402690	3/8" x 5-1/2"	5/25	6
462-060	402706	3/8" x 6"	5/25	8
462-080	403420	3/8" x 8"	5/25	10
462-120	403437	3/8" x 12"	5/25	16

1/2" NIPPLE

RED BRASS

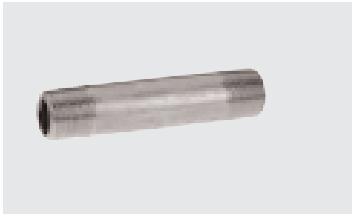

Part Number	UPC-A (032888)	Size	Inner/Master Carton Qty.	Master Weight (lbs.)
463-001	402805	1/2" x Close	5/25	2
463-015	402812	1/2" x 1-1/2"	5/25	3
463-020	402829	1/2" x 2"	5/25	3
463-025	402836	1/2" x 2-1/2"	5/25	4
463-030	402843	1/2" x 3"	5/25	5
463-035	402850	1/2" x 3-1/2"	5/25	6
463-040	402867	1/2" x 4"	5/25	7
463-045	402874	1/2" x 4-1/2"	5/25	8
463-050	402881	1/2" x 5"	5/25	9
463-055	402898	1/2" x 5-1/2"	5/25	10
463-060	402904	1/2" x 6"	5/25	11
463-080	403444	1/2" x 8"	5/25	15
463-100	403451	1/2" x 10"	5/25	19
463-120	403000	1/2" x 12"	5/25	24

3/4" NIPPLE

RED BRASS

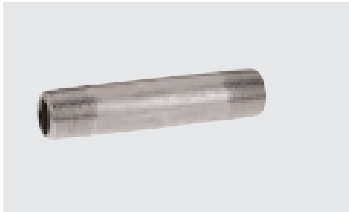

Part Number	UPC-A (032888)	Size	Inner/Master Carton Qty.	Master Weight (lbs.)
464-001	403000	3/4" x Close	5/25	3
464-015	403109	3/4" x 1-1/2"	5/25	4
464-020	403017	3/4" x 2"	5/25	5
464-025	403024	3/4" x 2-1/2"	5/25	6
464-030	403031	3/4" x 3"	5/25	7
464-035	403048	3/4" x 3-1/2"	5/25	9
464-040	403055	3/4" x 4"	5/25	10
464-045	403062	3/4" x 4-1/2"	5/25	11
464-050	403079	3/4" x 5"	5/25	13
464-055	403086	3/4" x 5-1/2"	5/25	14
464-060	403093	3/4" x 6"	5/25	16
464-080	403475	3/4" x 8"	5/25	21
464-100	403482	3/4" x 10"	5/10	11
464-120	403499	3/4" x 12"	5/25	32

1" NIPPLE

RED BRASS

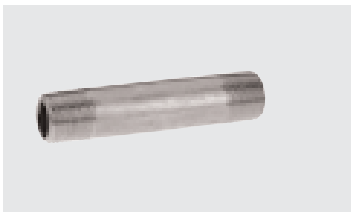

Part Number	UPC-A (032888)	Size	Inner/Master Carton Qty.	Master Weight (lbs.)
465-001	403208	1" x Close	5/25	4
465-020	403215	1" x 2"	5/25	6
465-025	403222	1" x 2-1/2"	5/25	8
465-030	403239	1" x 3"	5/25	10
465-035	403246	1" x 3-1/2"	5/25	12
465-040	403253	1" x 4"	5/25	13
465-045	403260	1" x 4-1/2"	5/25	15
465-050	403277	1" x 5"	5/25	17
465-055	403284	1" x 5-1/2"	5/25	19
465-060	403291	1" x 6"	5/25	21
465-080	403505	1" x 8"	5/25	28
465-100	403512	1" x 10"	5/25	37
465-120	403529	1" x 12"	5/10	43

TUBE & PIPE

METAL FITTINGS & NIPPLES

PLASTIC FITTINGS

VALVES

FILTER-DRIERS & STRAINERS



1-1/4" NIPPLE

RED BRASS

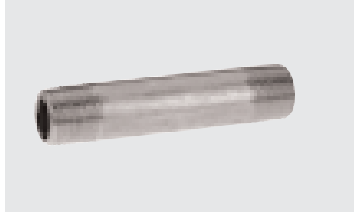

Part Number	UPC-A (032888)	Size	Inner/Master Carton Qty.	Master Weight (lbs.)
466-001	402928	1-1/4" x Close	5/10	3
466-020	402935	1-1/4" x 2"	5/10	4
466-025	402942	1-1/4" x 2-1/2"	5/25	12
466-030	402959	1-1/4" x 3"	5/10	6
466-035	402966	1-1/4" x 3-1/2"	5/10	7
466-040	402973	1-1/4" x 4"	5/10	8
466-045	402980	1-1/4" x 4-1/2"	5/10	9
466-050	402997	1-1/4" x 5"	5/10	10
466-055	403116	1-1/4" x 5-1/2"	5/25	28
466-060	403123	1-1/4" x 6"	5/10	13

1-1/2" NIPPLE

RED BRASS

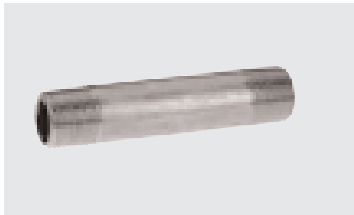

Part Number	UPC-A (032888)	Size	Inner/Master Carton Qty.	Master Weight (lbs.)
467-001	403130	1-1/2" x Close	5/10	4
467-020	403147	1-1/2" x 2"	5/10	5
467-025	403154	1-1/2" x 2-1/2"	5/10	6
467-030	403161	1-1/2" x 3"	5/10	7
467-035	403178	1-1/2" x 3-1/2"	5/10	8
467-040	403185	1-1/2" x 4"	5/10	10
467-045	403192	1-1/2" x 4-1/2"	5/10	12
467-050	403307	1-1/2" x 5"	5/10	12
467-055	403314	1-1/2" x 5-1/2"	5/10	14
467-060	403321	1-1/2" x 6"	5/10	15

2" NIPPLE

RED BRASS

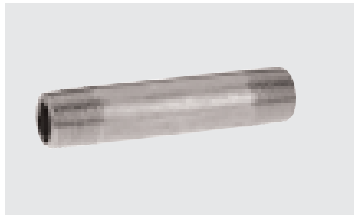

Part Number	UPC-A (032888)	Size	Inner/Master Carton Qty.	Master Weight (lbs.)
468-001	403338	2" x Close	5/10	6
468-025	403345	2" x 2-1/2"	5/10	8
468-030	403352	2" x 3"	5/10	10
468-035	403369	2" x 3-1/2"	5/10	11
468-040	403376	2" x 4"	5/10	13
468-045	403383	2" x 4-1/2"	5/10	14
468-050	403390	2" x 5"	5/10	16
468-055	403406	2" x 5-1/2"	5/25	44
468-060	403413	2" x 6"	5/10	20

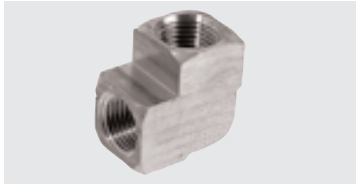
90° ELBOW**YELLOW BRASS**

Part Number	UPC-A (032888)	Size	Inner/Master Carton Qty.	Master Weight (lbs.)
470-000	700000	1/8"	5/25	2
470-001	700017	1/4"	5/25	3
470-002	700024	3/8"	5/25	5

90° ELBOW • STREET**YELLOW BRASS**

Part Number	UPC-A (032888)	Size	Inner/Master Carton Qty.	Master Weight (lbs.)
472-000	720008	1/8"	5/25	1
472-001	720015	1/4"	5/25	2
472-002	720022	3/8"	5/25	4

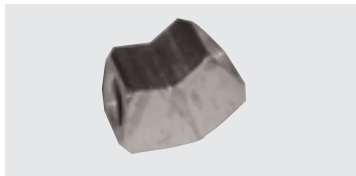
45° ELBOW**YELLOW BRASS**

Part Number	UPC-A (032888)	Size	Inner/Master Carton Qty.	Master Weight (lbs.)
471-000	710009	1/8"	5/25	2
471-001	710016	1/4"	5/25	3

45° ELBOW • STREET**YELLOW BRASS**

Part Number	UPC-A (032888)	Size	Inner/Master Carton Qty.	Master Weight (lbs.)
471-100	711006	1/8"	5/25	1
471-101	711013	1/4"	5/25	2

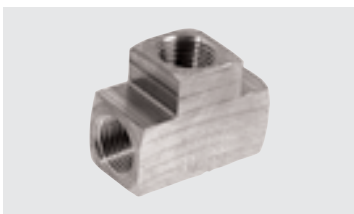
TEE**YELLOW BRASS**

Part Number	UPC-A (032888)	Size	Inner/Master Carton Qty.	Master Weight (lbs.)
473-000	730007	1/8"	5/25	3
473-001	730014	1/4"	5/25	4
473-002	730021	3/8"	5/25	6

COUPLING

YELLOW BRASS



Part Number	UPC-A (032888)	Size	Inner/Master Carton Qty.	Master Weight (lbs.)
474-000	740006	1/8"	5/25	1
474-001	740013	1/4"	5/25	1
474-002	740020	3/8"	5/25	2

BUSHING • HEX

YELLOW BRASS



Part Number	UPC-A (032888)	Size	Inner/Master Carton Qty.	Master Weight (lbs.)
475-010	750140	1/4" x 1/8"	5/25	1
575-020	750203	3/8" x 1/8"	5/25	2
475-021	750210	3/8" x 1/4"	5/25	2
575-030	750302	1/2" x 1/8"	5/25	3
475-031	750319	1/2" x 1/4"	5/25	3
475-032	750326	1/2" x 3/8"	5/25	2

BUSHING • FACE

YELLOW BRASS



Part Number	UPC-A (032888)	Size	Inner/Master Carton Qty.	Master Weight (lbs.)
456-032	401808	1/2" x 3/8"	5/25	1
456-043	401815	3/4" x 1/2"	5/25	2

CAP

YELLOW BRASS



Part Number	UPC-A (032888)	Size	Inner/Master Carton Qty.	Master Weight (lbs.)
476-000	760004	1/8"	5/25	1
476-001	760011	1/4"	5/25	2
476-002	760028	3/8"	5/25	2

PLUG SOLID

YELLOW BRASS



Part Number	UPC-A (032888)	Size	Inner/Master Carton Qty.	Master Weight (lbs.)
478-000	780002	1/8"	5/25	1
478-001	780019	1/4"	5/25	2
478-002	780026	3/8"	5/25	2

1/8" NIPPLE**YELLOW BRASS**

Part Number	UPC-A (032888)	Size	Inner/Master Carton Qty.	Master Weight (lbs.)
480-001	800014	1/8" x Close	5/25	1
480-015	800151	1/8" x 1-1/2"	5/25	1
480-020	800205	1/8" x 2"	5/25	1

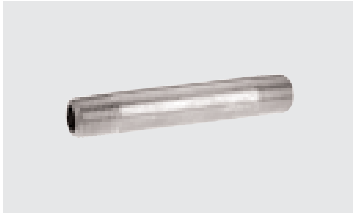
1/4" NIPPLE**YELLOW BRASS**

Part Number	UPC-A (032888)	Size	Inner/Master Carton Qty.	Master Weight (lbs.)
481-001	810013	1/4" x Close	5/25	1
481-020	810204	1/4" x 2"	5/25	2

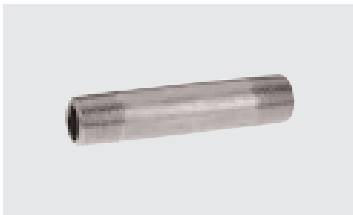
3/8" NIPPLE**YELLOW BRASS**

Part Number	UPC-A (032888)	Size	Inner/Master Carton Qty.	Master Weight (lbs.)
482-001	820012	3/8" x Close	5/25	1
482-015	820159	3/8" x 1-1/2"	5/25	2
482-010	820203	3/8" x 2"	5/25	5

TUBE & PIPE

METAL FITTINGS & NIPPLES

PLASTIC FITTINGS

VALVES

FILTER-DRIERS & STRAINERS



Brass Flare Fittings & Flanges



Complementary to a wide range of air conditioning and refrigeration components, Mueller provides brass flare fittings machined to assure tight leak proof joints. Manufactured since the 1920s, Mueller offers a complete range of universal fittings to meet industry requirements and standards. Choose a Mueller brass fitting and be confident of its performance quality ensuring unrestricted flow and reduced pressure drop.

PostScriptPicture

45° FLARE FITTINGS

BRASS

SHORT FORGED NUTS*

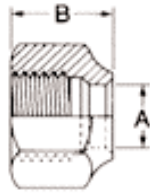

Cat. No.	Part No.	F Flare	Size		A		B	Pcs. Per Ctn.	Wt./Ea.
			Tube	Hex	Min.	Max.			
NS4-3	A 05238	3/16	3/16	1/2	.192	.197	17/32	50	.02
NS4-4	A 05051	1/4	1/4	5/8	.255	.260	19/32	50	.04
NS4-5	A 05239	5/16	5/16	1 1/16	.317	.320	5/8	25	.04
NS4-6	A 05052	3/8	3/8	1 3/16	.380	.385	1 1/16	25	.06
NS4-8	A 05053	1/2	1/2	1 5/16	.505	.510	1 3/16	15	.08
NS4-10	A 05157	5/8	5/8	1-1/16	.630	.635	1 5/16	10	.12
NS4-12	A 05222	3/4	3/4	1-5/16	.755	.760	1-1/8	10	.24

*Recognized under the component program of Underwriters Laboratories.

SHORT FORGED REDUCING NUTS*

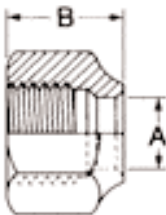
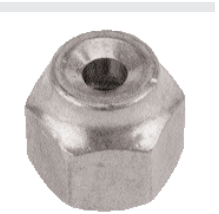

Cat. No.	Part No.	F Flare	Size		A		B	Pcs. Per Ctn.	Wt./Ea.
			Tube	Hex	Min.	Max.			
NRS4-43	A 05132	1/4	3/16	5/8	.192	.197	19/32	10	.04
NRS4-54	A 05247	5/16	1/4	1 1/16	.255	.260	5/8	10	.04
NRS4-64	A 05140	3/8	1/4	1 3/16	.255	.260	1 1/16	25	.06
NRS4-65	A 05282	3/8	5/16	1 3/16	.320	.325	1 1/16	10	.06
NRS4-86	A 05141	1/2	3/8	1 5/16	.380	.385	1 3/16	15	.10
NRS4-108	A 05228	5/8	1/2	1-1/16	.505	.510	1 5/16	15	.13

*Recognized under the component program of Underwriters Laboratories.

LONG FORGED NUTS*

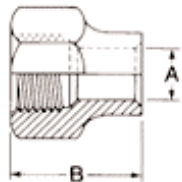

Cat. No.	Part No.	F Flare	Size		A		B	Pcs. Per Ctn.	Wt./Ea.
			Tube	Hex	Min.	Max.			
N4-4	A 00440	1/4	1/4	5/8	.255	.260	15/16	25	.06
N4-5	A 01110	5/16	5/16	1 1/16	.317	.322	15/16	25	.05
N4-6	A 00441	3/8	3/8	1 3/16	.380	.385	1-1/16	25	.08
N4-8	A 00442	1/2	1/2	1 5/16	.505	.510	1-3/16	10	.13
N4-10	A 01112	5/8	5/8	1-1/16	.630	.635	1-7/16	5	.19
N4-12	A 04731	3/4	3/4	1-5/16	.755	.760	1-3/4	5	.36

*Recognized under the component program of Underwriters Laboratories.

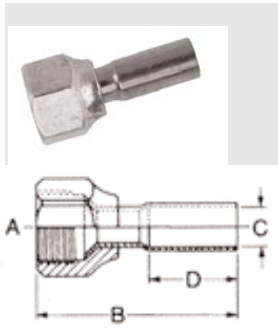

INTERNAL FLARE TO EXTENSION SOLDER

Cat. No.	Part No.	A	B	C	D	Pcs. Per Ctn.	Wt./Ea.
US5-44	A 15725	1/4	1-5/8	1/4	13/16	25	.042
US5-66	A 15726	3/8	1-11/16	3/8	13/16	25	.061
US5-88	A 15727	1/2	1-15/16	1/2	7/8	20	.104
US5-1010	A 15728	5/8	2-5/16	5/8	1	10	.161
US5-1212	A 15729	3/4	2-7/8	3/4	1-1/4	10	.218

Recognized under the component program of Underwriters Laboratories.



CONNECTORS, HALF UNION – FLARE TO NPTFE

Cat. No.	Part No.	Size		C	D	E	Size Hex	Pcs. Per Ctn.	Wt./Ea.
		Flare A	NPTFE B						
UI-3A	A 01117	3/16	1/8	1	3/8	3/16	7/16	15	.03
UI-4A	A 00330	1/4	1/8	1-1/16	3/8	3/16	7/16	25	.03
UI-4B	A 04585	1/4	1/4	1-1/4	9/16	3/16	9/16	25	.05
UI-4C	A 01197	1/4	3/8	1-5/16	9/16	1/4	11/16	25	.07
UI-4D	A 04628	1/4	1/2	1-9/16	3/4	5/16	7/8	25	.11
UI-5A	A 00331	5/16	1/8	1-5/32	3/8	5/16	1/2	25	.04
UI-5B	A 05036	5/16	1/4	1-11/32	9/16	7/32	9/16	25	.06
UI-5C	A 01198	5/16	3/8	1-3/8	9/16	1/4	11/16	25	.08
UI-6A	A 05003	3/8	1/8	1-1/4	3/8	1/4	5/8	25	.07
UI-6B	A 00332	3/8	1/4	1-7/16	9/16	1/4	5/8	25	.08
UI-6C	A 01199	3/8	3/8	1-7/16	9/16	1/4	11/16	25	.09
UI-6D	A 04993	3/8	1/2	1-11/16	3/4	5/16	7/8	25	.14
UI-8A	A 05034	1/2	1/8	1 7/16	3/8	5/16	3/4	10	.10
UI-8B	A 04439	1/2	1/4	1-5/8	9/16	5/16	3/4	10	.11
UI-8C	A 00334	1/2	3/8	1-5/8	9/16	5/16	3/4	10	.11
UI-8D	A 04780	1/2	1/2	1-13/16	3/4	5/16	7/8	10	.15
UI-8E	A 05066	1/2	3/4	1-15/16	3/4	7/16	1-1/16	10	.21
UI-10B	A 05035	5/8	1/4	1-13/16	9/16	3/8	7/8	10	.16
UI-10C	A 01195	5/8	3/8	1-13/16	9/16	3/8	7/8	10	.17
UI-10D	A 04540	5/8	1/2	2	3/4	3/8	7/8	10	.18
UI-10E	A 04827	5/8	3/4	2-1/16	3/4	7/16	1-1/16	5	.24
UI-12C	A 05005	3/4	3/8	2	9/16	7/16	1-1/16	25	.27
UI-12D	A 04739	3/4	1/2	2-3/16	3/4	7/16	1-1/16	5	.25
UI-12E	A 04740	3/4	3/4	2-3/16	3/4	7/16	1-1/16	5	.33

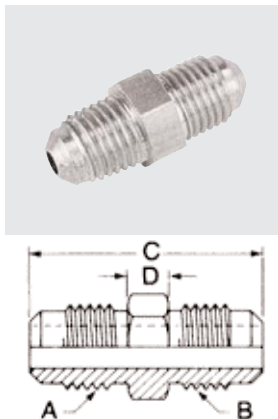

UNION – FLARE TO FLARE

Cat. No.	Part No.	Size		C	D	Size Hex	Pcs. Per Ctn.	Wt./Ea.
		Flare A	Flare B					
U2-3	A 04621	3/16	3/16	1-1/16	3/16	3/8	25	.03
U2-4	A 00325	1/4	1/4	1-3/16	3/16	7/16	25	.04
U2-5	A 00326	5/16	5/16	1-11/32	7/32	1/2	25	.06
U2-6	A 00327	3/8	3/8	1-1/2	1/4	5/8	25	.09
U2-8	A 00329	1/2	1/2	1-13/16	5/16	3/4	15	.15
U2-10	A 04845	5/8	5/8	2-1/8	3/8	7/8	10	.22
U2-12	A 04733	3/4	3/4	2-7/16	7/16	11/16	10	.37



45° FLARE FITTINGS

BRASS

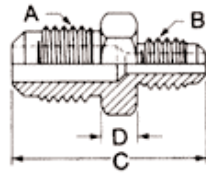

REDUCING UNION – FLARE TO FLARE

Cat. No.	Part No.	Size				Size Hex	Pcs. Per Ctn.	Wt./Ea.
		Flare A	Flare B	C	D			
UR2-43	A 05270	1/4	3/16	1-1/8	3/16	7/16	15	.03
UR2-54	A 08730	5/16	1/4	1-9/32	7/32	1/2	10	.05
UR2-64	A 01171	3/8	1/4	1-3/8	1/4	5/8	15	.07
UR2-65	A 04981	3/8	5/16	1-7/16	1/4	5/8	10	.08
UR2-84	A 00356	1/2	1/4	1-9/16	5/16	3/4	15	.12
UR2-86	A 00149	1/2	3/8	1-11/16	5/16	3/4	25	.14
UR2-106	A 05334	5/8	3/8	1-7/8	3/8	7/8	10	.18
UR2-108	A 04846	5/8	1/2	2	3/8	7/8	12	.19
UR2-128	A 04734	3/4	1/2	2-3/16	7/16	11/16	10	.31
UR2-1210	A 04784	3/4	5/8	2-5/16	7/16	11/16	10	.33

EXTERNAL FLARE CONNECTORS, HALF UNION – EXTERNAL FLARE TO SOLDER

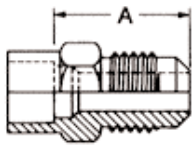

Cat. No.	Part No.	Size			Size Hex	Pcs. Per Ctn.	Wt./Ea.
		Flare	OD Solder	A			
US3-44	A 03431	1/4	1/4	11/16	7/16	25	.03
US3-45	A 03466	1/4	5/16	11/16	7/16	25	.04
US3-46	A 03494	1/4	3/8	11/16	1/2	25	.03
US3-64	A 03443	3/8	1/4	7/8	5/8	25	.08
US3-65	A 03464	3/8	5/16	7/8	5/8	25	.07
US3-66	A 03492	3/8	3/8	7/8	5/8	25	.06
US3-68	A 03547	3/8	1/2	7/8	5/8	10	.08
US3-610	A 06601	3/8	5/8	7/8	3/4	10	.08
US3-86	A 03504	1/2	3/8	1-1/16	3/4	25	.11
US3-88	A 03546	1/2	1/2	1-1/16	3/4	15	.11
US3-810	A 02259	1/2	5/8	1-1/16	3/4	10	.10
US3-108	A 03519	5/8	1/2	1-1/4	7/8	10	.16
US3-1010	A 02258	5/8	5/8	1-1/4	7/8	10	.15
US3-1012	A 02272	5/8	3/4	1-1/4	7/8	10	.15
US3-1014	A 02378	5/8	7/8	1-1/4	1	10	.17
US3-1212	A 05307	3/4	3/4	1-7/16	1 1/16	5	.25
US3-1214	A 05425	3/4	7/8	1-5/16	1 1/16	5	.28

CONNECTORS, HALF UNION – FLARE TO NPTFI

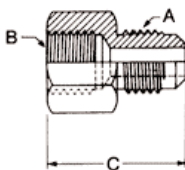

Cat. No.	Part No.	Size			Size Hex	Pcs. Per Ctn.	Wt./Ea.
		Flare A	NPTFI B	C			
U3-4A	A 04622	1/4	1/8	1-1/32	9/16	25	.04
U3-4B	A 04625	1/4	1/4	1-1/4	11/16	25	.07
U3-4C	A 04961	1/4	3/8	1-9/32	13/16	15	.08
U3-6A	A 04927	3/8	1/8	1-1/8	5/8	10	.06
U3-6B	A 04624	3/8	1/4	1-5/16	11/16	25	.09
U3-6C	A 04627	3/8	3/8	1-3/8	13/16	15	.10
U3-6D	A 08104	3/8	1/2	1-5/8	1	15	.16
U3-8B	A 04928	1/2	1/4	1-13/32	3/4	15	.11
U3-8C	A 04727	1/2	3/8	1-1/2	13/16	15	.12
U3-8D	A 04728	1/2	1/2	1-3/4	1	15	.18
U3-10C	A 04929	5/8	3/8	1-19/32	7/8	10	.15
U3-10D	A 04819	5/8	1/2	1-13/16	1	10	.20
U3-10E	A 04977	5/8	3/4	1-29/32	1 1/4	10	.36

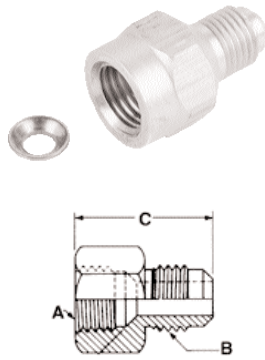

INTERNAL FLARE TO EXTERNAL FLARE UNION

Cat. No.	Part No.	Size			Size Hex	Pcs. Per Ctn.	Wt./Ea.
		Flare A	Flare B	C			
UR3-43	A 05147	1/4	3/16	1-1/32	5/8	10	.05
UR3-46	A 05041	1/4	3/8	1-1/8	5/8	15	.04
UR3-48	A 08127	1/4	1/2	1-1/4	3/4	10	.11
UR3-64	A 00479	3/8	1/4	1-7/32	13/16	15	.09
UR3-68	A 04888	3/8	1/2	1-13/32	13/16	15	.12
UR3-84	A 00480	1/2	1/4	1-3/8	15/16	15	.11
UR3-86	A 00481	1/2	3/8	1-7/16	15/16	15	.13
UR3-810	A 04879	1/2	5/8	1-5/8	15/16	10	.19
UR3-108	A 04770	5/8	1/2	1-11/16	1 1/16	10	.18
UR3-1012	A 04878	5/8	3/4	1-29/32	1 1/16	10	.29
UR3-1210	A 04826	3/4	5/8	1-31/32	1 5/16	10	.30

1 Soft Copper Gasket Furnished With Each Part

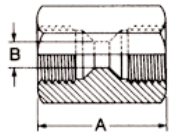

INTERNAL FLARE UNION

Cat. No.	Part No.	Size		A	B	Pcs. Per Ctn.	Wt./Ea.
		Flare	Hex				
U4-4	A 00385	1/4	5/8	1	1/4	10	.08
U4-6	A 00386	3/8	13/16	1-1/4	3/8	10	.12
U4-8	A 00387	1/2	15/16	1-7/16	1/2	10	.19

2 Soft Copper Gasket Furnished With Each Part

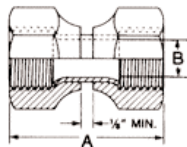

INTERNAL FLARE SWIVEL UNION

Cat. No.	Part No.	Size		A	B	Pcs. Per Ctn.	Wt./Ea.
		Flare	Hex				
US4-4	A 13563	1/4	5/8	1-3/8	3/16	15	.12
US4-5	A 13564	5/16	11/16	1-7/16	1/4	15	.10
US4-6	A 13565	3/8	13/16	1-9/16	5/16	15	.16
US4-8	A 13567	1/2	15/16	1-13/16	7/16	15	.24
US4-10	A 13568	5/8	1-1/16	2-1/16	9/16	15	.35

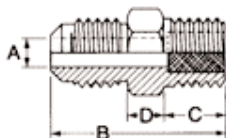

FUSIBLE CONNECTORS, HALF UNION – FLARE TO FPTFE

Cat. No.	UL Part No.	CE Part No.	Flare	Size NPTFE	Size		A		B		C		D	Melting Temp.*	Per Ctn.	Wt./Ea.
					Hex	in.	cm	in.	cm	in.	cm					
FU-4B	A 14062	B 35136	1/4	1/4	9/16	3/16	.48	1-1/4	3.18	9/16	1.43	3/16	.48	283°F	10	.07
FU-4C	A 14063	B 35137	1/4	3/8	11/16	3/16	.48	1-5/16	3.33	9/16	1.43	1/4	.64	283°F	10	.09
FU-6C	A 14064	B 35138	3/8	3/8	11/16	9/32	.71	1-7/16	3.65	9/16	1.43	1/4	.64	283°F	10	.12
FU-4B	A 14023	B 35127	1/4	1/4	9/16	3/16	.48	1-1/4	3.18	9/16	1.43	3/16	.48	210°F	10	.06
FU-4C	A 14025	B 35129	1/4	3/8	11/16	3/16	.48	1-5/16	3.33	9/16	1.43	1/4	.64	210°F	10	.09
FU-6C	A 14026	B 35130	3/8	3/8	11/16	9/32	.71	1-7/16	3.65	9/16	1.43	1/4	.64	210°F	10	.12
FU-4B	A 14024	B 35128	1/4	1/4	9/16	3/16	.48	1-1/4	3.18	9/16	1.43	3/16	.48	168°F	10	.06
FU-4C	A 14050	B 35132	1/4	3/8	11/16	3/16	.48	1-5/16	3.33	9/16	1.43	1/4	.64	168°F	10	.09
FU-6C	A 14027	B 35131	3/8	3/8	11/16	9/32	.71	1-7/16	3.65	9/16	1.43	1/4	.64	168°F	10	.13

Listed by Underwriters Laboratories, Inc., for use in the USA and Canada.

CE Compliant for European market.



45° FLARE FITTINGS

BRASS

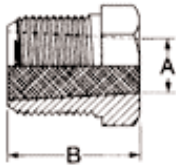

FUSIBLE PIPE PLUGS

Cat. No.	UL Part No.	CE Part No.	Size		A		B		Melting Temp.*	Per Ctn.	Wt./ Ea.
			NPTFE	Hex	in	cm	in	cm			
FP-A	A 14058	B 35133	1/8	7/16	7/32	.56	19/32	1.51	283°F	10	.02
FP-B	A 14059	B 35134	1/4	9/16	1/4	.64	25/32	1.98	283°F	15	.05
FP-C	A 14060	B 35135	3/8	1 1/16	3/8	.95	27/32	2.14	283°F	15	.08
FP-A	A 14017	B 35122	1/8	7/16	7/32	.56	19/32	1.51	210°F	10	.03
FP-B	A 14018	B 35123	1/4	9/16	1/4	.64	25/32	1.98	210°F	15	.05
FP-C	A 14021	B 35125	3/8	1 1/16	3/8	.95	27/32	2.14	210°F	15	.06
FP-A	A 15214	B 35139	1/8	7/16	7/32	.56	19/32	1.51	168°F	10	.02
FP-B	A 14019	B 35124	1/4	9/16	1/4	.64	25/32	1.98	168°F	15	.04
FP-C	A 14022	B 35126	3/8	1 1/16	3/8	.95	27/32	2.14	168°F	15	.06

Listed by Underwriters Laboratories, Inc., for use in the USA and Canada.
CE Compliant for European market.

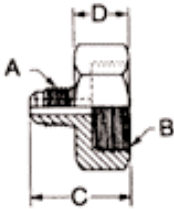
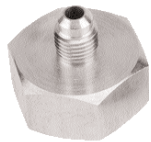

REFRIGERANT DRUM ADAPTERS

Cat. No.	Part No.	Size		C	D	Hex	Pcs. Per Ctn.	Wt./Ea.	Replacement Gasket
		Flare A	NPSM B						
KI-1	A 08073	1/4	3/4	1-1/8	7/16	1-1/4	10	.16	
KI-3	A 08274	3/8	3/4	1-1/4	7/16	1-1/4	10	.19	A 08074
KI-5	A 08276	1/2	3/4	1-3/8	7/16	1-1/4	10	.19	
KI-8	A 08166	1/4	1/2	1-1/8	7/16	1-1/8	10	.15	A 08167

Furnished with Gasket
Flare to Internal Straight Pipe (NPSM)

90° ELBOWS, HALF UNION – FLARE TO NPTFE

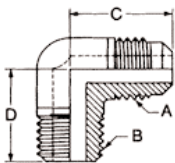

Cat. No.	Part No.	Size		C	D	Pcs. Per Ctn.	Wt. /Ea.
		Flare A	NPTFE B				
EI-4A	A 00335	1/4	1/8	15/16	25/32	25	.04
EI-4B	A 04890	1/4	1/4	29/32	15/16	25	.08
EI-4C	A 04812	1/4	3/8	15/16	1-1/32	25	.09
EI-6A	A 04937	3/8	1/8	1-1/32	29/32	25	.08
EI-6B	A 00337	3/8	1/4	1-1/16	1-1/16	25	.09
EI-6C	A 04889	3/8	3/8	1-1/16	1-3/32	25	.11
EI-6D	A 04886	3/8	1/2	1-1/8	1-11/32	25	.16
EI-8B	A 05044	1/2	1/4	1-7/32	1-3/16	10	.13
EI-8C	A 00339	1/2	3/8	1-7/32	1-1/8	15	.17
EI-8D	A 04887	1/2	1/2	1-9/32	1-3/8	15	.17
EI-8E	A 05072	1/2	3/4	1-11/32	1-3/8	10	.24
EI-10C	A 04856	5/8	3/8	1-15/32	1-1/4	10	.17
EI-10D	A 04538	5/8	1/2	1-15/32	1-7/16	10	.20
EI-10E	A 05054	5/8	3/4	1-15/32	1-1/2	10	.26
EI-12D	A 04776	3/4	1/2	1-21/32	1-1/2	10	.32
EI-12E	A 04746	3/4	3/4	1-21/32	1-5/8	10	.35

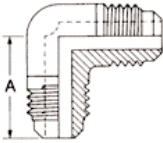

90° ELBOW, UNION – FLARE TO FLARE

Cat. No.	Part No.	Size		Pcs. Per Ctn.	Wt./Ea.
		Flare	A		
E2-4	A 00147	1/4	29/32	25	.07
E2-6	A 00146	3/8	1-1/16	25	.10
E2-8	A 00145	1/2	1-7/32	15	.14
E2-10	A 04539	5/8	1-15/32	10	.21
E2-12	A 04745	3/4	1-21/32	5	.39

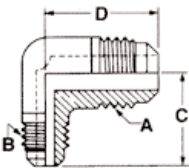

90° ELBOW, REDUCING UNION – FLARE TO FLARE

Cat. No.	Part No.	Size				Pcs. Per Ctn.	Wt./Ea.
		A	B	C	D		
ER2-84	A 04885	1/2	1/4	1-7/32	3-1/32	25	.13
ER2-86	A 05042	1/2	3/8	1-7/32	1-1/8	25	.17

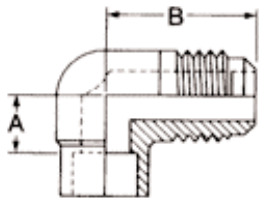
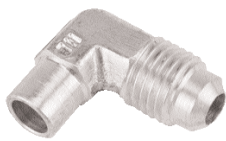

90° SOLDER ELBOW, HALF UNION – FLARE TO SOLDER

Cat. No.	Part No.	Size				Pcs. Per Ctn.	Wt./Ea.
		Flare	OD Solder	A	B		
ES2-44	A 03449	1/4	1/4	23/64	29/32	25	.04
ES2-66	A 03511	3/8	3/8	15/32	1-5/64	20	.08
ES2-68	A 07852	3/8	1/2	13/32	1-3/64	10	.11
ES2-88	A 07851	1/2	1/2	15/32	1-7/32	—	.12
ES2-1010	A 06611	5/8	5/8	35/64	1-13/32	—	.19

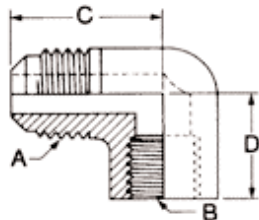
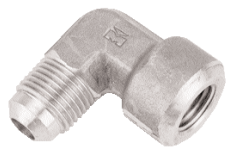

90° ELBOW – EXTERNAL FLARE TO NPTFI

Cat. No.	Part No.	Size				Pcs. Per Ctn.	Wt./Ea.
		Flare	NPTFI	A	B		
E3-4A	A 04630	1/4	1/8	29/32	29/32	25	.06
E3-4B	A 05007	1/4	1/4	1-1/16	21/32	25	.13
E3-6B	A 04632	3/8	1/4	1-1/8	1-1/8	25	.15
E3-6C	A 04914	3/8	3/8	1-9/64	3/4	25	.19
E3-8D	A 05056	1/2	1/2	1-3/8	15/16	15	.33



45° FLARE FITTINGS

BRASS

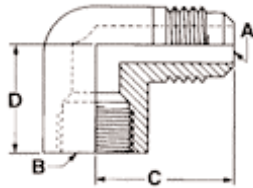

90° ELBOW – EXTERNAL FLARE TO INTERNAL FLARE

Cat. No.	Part No.	Size				Pcs. Per Ctn.	Wt. /Ea.
		Flare A	Flare B	C	D		
E4-44	A 04898	1/4	1/4	15/16	7/8	25	.13
E4-66	A 08082	3/8	3/8	1-7/32	1-1/16	25	.24
E4-88	A 04897	1/2	1/2	1-11/32	1-1/8	15	.22

1 Soft Copper Gasket Furnished With Each Part

90° SWIVEL ELBOW – EXTERNAL FLARE TO INTERNAL FLARE

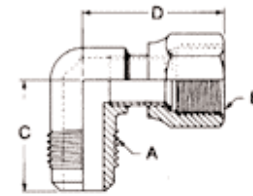

Cat. No.	Part No.	Size				Pcs. Per Ctn.	Wt. /Ea.
		Flare A	Flare B	C	D		
ES4-44	A 15940	1/4	1/4	29/32	1-1/4	4	.13
ES4-66	A 15941	3/8	3/8	1-5/64	1-27/64	4	.19
ES4-88	A 15943	1/2	1/2	1-7/32	1-17/32	4	.22
ES4-1010	A 15944	5/8	5/8	1-13/32	1-3/4	4	.31
ES4-1212	A 15945	3/4	3/4	1-21/32	2-1/32	4	.58

RIGHT ANGLE TWO-WAY TEES

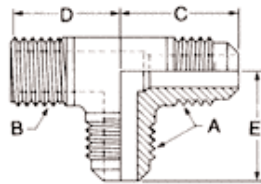

Cat. No.	Part No.	Size					Pcs. Per Ctn.	Wt./Ea.
		Flare A	NPTFE B	C	D	E		
T3-4A	A 00127	1/4	1/8	15/16	51/64	15/16	25	.08
T3-4B	A 04998	1/4	1/4	15/16	1-1/16	15/16	25	.11
T3-6B	A 00133	3/8	1/4	1-1/16	1-1/16	1-1/16	25	.14
T3-6C	A 04941	3/8	3/8	1-1/16	1-3/32	1-1/16	25	.15
T3-8C	A 04778	1/2	3/8	1-7/32	1-1/8	1-7/32	15	.18
T3-8D	A 04944	1/2	1/2	1-11/32	1-3/8	1-11/32	10	.26
T3-10D	A 04779	5/8	1/2	1-13/32	1-3/8	1-13/32	10	.28

TWO-WAY TEES

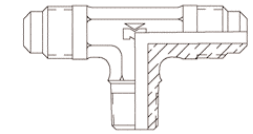

Cat. No.	Part No.	Size				Pcs. Per Ctn.	Wt. /Ea.
		Flare A	NPTFE B	C	D		
T1-4A	A 00345	1/4	1/8	15/16	13/16	25	.07
T1-4B	A 04859	1/4	1/4	29/32	1-1/32	25	.09
T1-4C	A 04771	1/4	3/8	15/16	1-1/32	15	.12
T1-6B	A 00347	3/8	1/4	1-1/16	1-1/16	25	.11
T1-6C	A 04922	3/8	3/8	1-1/16	1-1/16	15	.14
T1-8B	A 05246	1/2	1/4	1-7/32	1-3/16	12	.18
T1-8C	A 00349	1/2	3/8	1-7/32	1-1/8	15	.19
T1-8D	A 04924	1/2	1/2	1-11/32	1-3/8	10	.26
T1-10D	A 04754	5/8	1/2	1-13/32	1-3/8	10	.28

THREE-WAY TEES

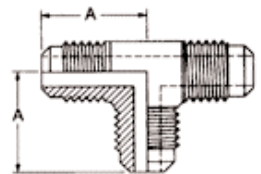

Cat. No.	Part No.	Size		Pcs. Per Ctn.	Wt./Ea.
		Flare	A		
T2-4	A 00340	1/4	15/16	25	.07
T2-6	A 00342	3/8	1-1/16	15	.17
T2-8	A 00344	1/2	1-7/32	15	.20
T2-10	A 04541	5/8	1-13/32	10	.30
T2-12	A 04749	3/4	1-21/32	5	.68

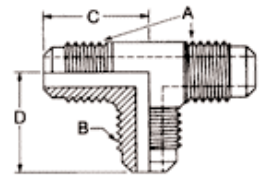
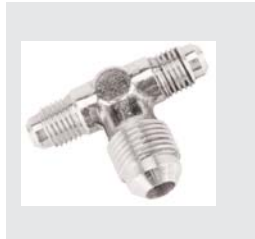

THREE-WAY REDUCING TEES

Cat. No.	Part No.	Size		C	D	Pcs. Per Ctn.	Wt. /Ea.
		Flare A	Flare B				
TR2-46	A 04994	1/4	3/8	29/32	1-1/16	25	.11
TR2-64	A 04574	3/8	1/4	1-1/16	29/32	25	.12
TR2-68	A 04547	3/8	1/2	1-1/8	1-7/32	15	.19
TR2-84	A 04558	1/2	1/4	1-7/32	31/32	10	.21
TR2-86	A 04559	1/2	3/8	1-7/32	1-1/8	15	.22
TR2-810	A 04991	1/2	5/8	1-11/32	1-13/32	10	.28

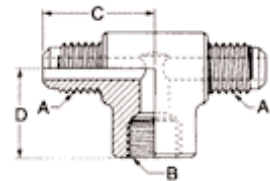

THREE-WAY TEES – INTERNAL BRANCH

Cat. No.	Part No.	Size		C	D	Pcs. Per Ctn.	Wt. /Ea.
		Flare A	Flare B				
T6-4	A 06330	1/4	1/4	15/16	29/32	25	.14

1 Soft Copper Gasket Furnished With Each Part

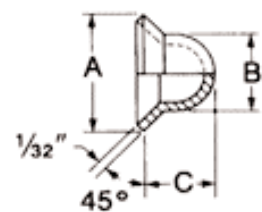

COPPER FLARE SEAL BONNETS

Cat. No.	Part No.	Size Flare	Size			Pcs. Per Ctn.	Wt./Ea.
			A Max.	B +/- 1/64	C Min.		
B1-3	A 04737	3/16	5/16	5/32	5/32	25	.001
B1-4	A 00414	1/4	23/64	7/32	7/32	100	.001
B1-5	A 04935	5/16	27/64	9/32	9/32	50	.004
B1-6	A 00415	3/8	35/64	23/64	11/32	25	.004
B1-8	A 00416	1/2	21/32	15/32	13/32	100	.008
B1-10	A 00485	5/8	49/64	39/64	7/16	20	.009
B1-12	A 04738	3/4	61/64	23/32	9/16	25	.015

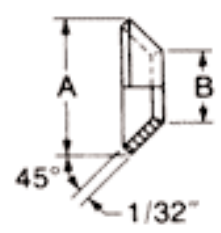

COPPER FLARE GASKETS

Cat. No.	Part No.	Size Flare	Size		Pcs. Per Ctn.	Wt./Ea.
			A Max.	B +/- 1/32		
B2-3	A 05156	3/16	5/16	1/8	50	.001
B2-4	A 00401	1/4	23/64	3/16	100	.001
B2-5	A 04811	5/16	27/64	7/32	50	.001
B2-6	A 00402	3/8	35/64	9/32	100	.002
B2-8	A 00403	1/2	21/32	13/32	100	.002
B2-10	A 05186	5/8	49/64	1/2	50	.003
B2-12	A 04822	3/4	61/64	5/8	25	.004

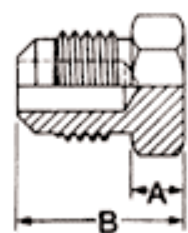

FLARE PLUGS

Cat. No.	Part No.	Size Flare	Size		Size Hex	Pcs. Per Ctn.	Wt./Ea.
			A Max.	B +/- 1/32			
P2-3	A 05045	3/16	5/32	19/32	3/8	15	.01
P2-4	A 00121	1/4	3/16	11/16	7/16	25	.02
P2-5	A 00124	5/16	7/32	25/32	1/2	15	.03
P2-6	A 00122	3/8	1/4	7/8	5/8	25	.06
P2-8	A 00123	1/2	5/16	1-1/16	3/4	25	.09
P2-10	A 04536	5/8	5/16	1-3/16	7/8	15	.14
P2-12	A 04757	3/4	5/16	1-5/16	1-1/16	10	.23



45° FLARE FITTINGS

BRASS

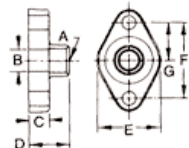
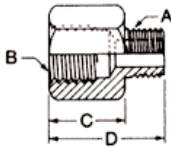
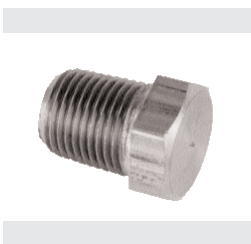
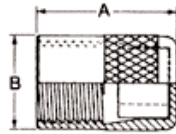
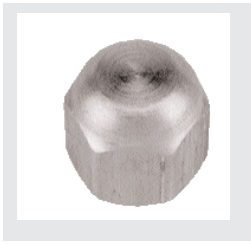

FLARE SEAL CAP

Cat. No.	Part No.	Size			Size Hex	Pcs. Per Ctn.	Wt./Ea.
		Flare	A	B			
N5-4	A 04544	1/4	11/32	9/16	9/16	50	.03
N5-5	A 04758	5/16	3/8	9/16	5/8	25	.03
N5-6	A 04545	3/8	7/16	11/16	3/4	25	.05
N5-8	A 04546	1/2	35/64	13/16	7/8	25	.08
N5-10	A 04560	5/8	5/8	15/16	1-1/16	10	.14
N5-12	A 04951	3/4	3/4	1-3/32	1-5/16	10	.21

FLARE SEAL CAPS W/NEOPRENE SEAL GASKET*

Cat. No.	Part No.	Size			Pcs. Per Ctn.	Wt./Ea.
		Flare	A	B		
NFT5-4	A 16447	1/4	9/16	31/64	3500	.02
NFT5-6	A 16448	3/8	47/64	43/64	1400	.04

Finger Tightening*

PIPE PLUGS

Cat. No.	Part No.	Size			Size Hex	Pcs. Per Ctn.	Wt./Ea.
		NPTFE	A	B			
P3-A	A 00250	1/8	3/16	5/8	1/2	50	.03
P3-B	A 00249	1/4	1/4	13/16	11/16	50	.06
P3-C	A 00425	3/8	1/4	3/4	11/16	25	.07
P3-D	A 04759	1/2	5/16	7/8	7/8	25	.13
P3-E	A 05004	3/4	5/16	1-1/32	1 1/8	10	.21

BUSHINGS – EXTERNAL PIPE THREAD TO INTERNAL PIPE THREAD

Cat. No.	Part No.	A	Size		D	Hex	Size Per Ctn.	Pcs. Wt./Ea.
			NPTFE	NPTFI				
RI-AB	A 08756	1/8	1/4	39/64	59/64	11/16	25	.05
RI-BA	A 00630	1/4	1/8	3/32	19/32	9/16	25	.02
RI-CB	A 00631	3/8	1/4	3/16	11/16	11/16	25	.04
RI-DB	A 00492	1/2	1/4	3/16	3/4	7/8	25	.08
RI-DC	A 00632	1/2	3/8	3/16	3/4	7/8	25	.05
RI-EC	A 00493	3/4	3/8	3/16	13/16	1-1/16	10	.11
RI-ED	A 00633	3/4	1/2	3/16	13/16	1-1/16	10	.09

FLANGE – FORGED BRASS – 2 BOLT HOLE W/SERRATED GASKET SURFACE

Part No.	Size OD Solder		Bolt Hole Centers					Dia Of Bolt Holes	Wt./Ea.
	A	B	C	D	E	F	G		
A 08314	5/8	9/16	3/4	1 3/16	1-1/2	1-5/8	13/16	11/32	.45
A 05299	3/4	11/16	3/4	1-5/16	1-1/2	1-5/8	13/16	3/8	.42
A 09215	7/8	13/16	3/4	1-7/16	1-1/2	1-5/8	13/16	11/32	.42
A 08315	7/8	13/16	3/4	1-7/16	2-1/4	2-3/4	1-3/8	17/32	1.08
A 05151	1-1/8	1-1/16	3/4	1-9/16	2-1/4	2-3/4	1-3/8	17/32	1.11
A 05074	1-3/8	1-19/64	3/4	1-17/32	2-1/4	2-3/4	1-3/8	17/32	1.00

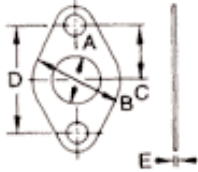
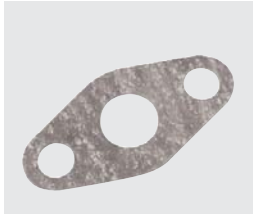

GASKETS – 2 BOLT HOLE – ASBESTOS-FREE MATERIAL

Part No.	A	B	C	Bolt Hole Centers		Dia Of Bolt Holes	Wt./Ea.
				D	E		
A 04582	9/16	1 1/8	13/16	1-5/8	1/32	11/32	.003
N 02308	13/16	1 1/2	13/16	1-5/8	1/32	11/32	.004
N 02307	13/16	1 1/2	7/8	1-3/4	1/32	11/32	.004
A 05152	1 3/16	2 1/4	1-3/8	2-3/4	1/16	17/32	.002
P 36396	1 5/16	2 1/4	3-1/8	2-3/4	1/16	17/32	.002

FLANGE BOLTS AND NUTS

Part No.	Asbestos-Free Material Description	Wt./Ea.
A 06567	1/2-13 Bolt - 2-1/4 long (For 17/32 Dia. Hole)	.15
A 06569	Nut For Above	.04

FLANGES – FORGED BRASS – 4 BOLT HOLE WITH GROOVE

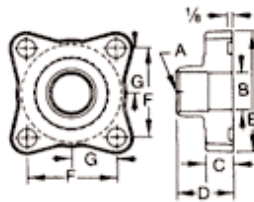
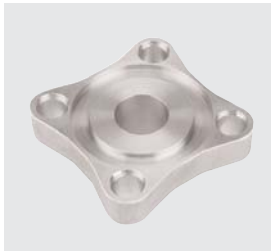

Part No.	Size Solder		C	D	E	Bolt Hole Centers		Dia Of Bolt Holes	Wt./Ea.
	A	B				F	G		
A 08630	1-1/8	1-1/16	3/4	1-9/16	3-13/32	2-1/2	1-1/4	17/32	1.88
A 08631	1-3/8	1-19/64	3/4	1-5/8	3-13/32	2-1/2	1-1/4	17/32	1.75
A 08261	1-5/8	1-17/32	3/4	1-3/4	3-13/32	2-1/2	1-1/4	17/32	1.69
A 08633	2-1/8	1-15/16	3/4	1-23/32	3-13/32	2-1/2	1-1/4	17/32	1.38

Gasket - Asbestos-free material

Part No. A 8634 used for 4 bolt-hole tongue and groove flanges.

Groove diameters 2-25/32" x 2-1/16"

FLANGES – FORGED BRASS – 4 BOLT HOLE WITH TONGUE

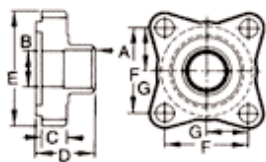
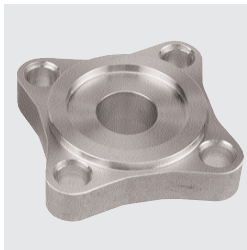

Part No.	Size Solder		C	D	E	Bolt Hole Centers		Dia Of Bolt Holes	Wt./Ea.
	A	B				F	G		
A 08629	1-1/8	1-1/16	3/4	1-23/32	3-13/32	2 1/2	1-1/4	17/32	2.06
A 05150	1-3/8	1-19/64	3/4	1-25/32	3-13/32	2 1/2	1-1/4	17/32	2.00
A 05148	1-5/8	1-17/32	3/4	1-29/32	3-13/32	2 1/2	1-1/4	17/32	1.94
A 08632	2-1/8	1-15/16	3/4	1-7/8	3-13/32	2 1/2	1-1/4	17/32	1.63

Groove Diameters 2-3/4" x 2-3/16"

FLANGES – FORGED BRASS – 4 BOLT HOLE WITH TONGUE

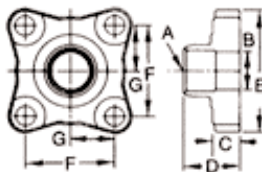
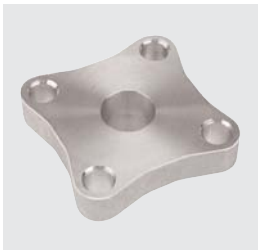

Part No.	Size Solder		C	D	E	Bolt Hole Centers		Dia Of Bolt Holes	Wt./Ea.
	A	B				F	G		
A 08624	1-1/8	1-1/16	3/4	1-9/16	3-13/32	2-1/2	1-1/4	17/32	1.94
A 08625	1-3/8	1-19/64	3/4	1-5/8	3-13/32	2-1/2	1-1/4	17/32	1.88
A 08626	1-5/8	1-17/32	3/4	1-13/16	3-13/32	2-1/2	1-1/4	17/32	1.88
A 08627	2-1/8	1-1/64	3/4	1-23/32	3-13/32	2-1/2	1-1/4	17/32	1.50

GASKET – 4 BOLT HOLE

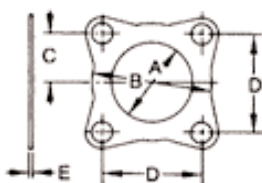

Part No.	A	B	C	D	E	Dia Of Bolt Holes	Wt./Ea.
A 08628	2 1/16	3	1 1/4	2 1/2	1/32	9/16	.01

Asbestos-Free Compound



PVC Sch. 40 Pressure Fittings



Superior strength and enhanced performance are the hallmarks of Mueller's PVC Schedule 40 pressure plastic fittings. With the heritage of being designed and tested under real world "cyclic" pressure conditions, Mueller's pressure plastic fittings have what it takes to stand up to what the "real world" dishes out. Along with superior strength comes superior performance; like excellent corrosion resistance, smoother inner walls for low pressure drops and excellent chemical resistance. Mueller offers a full line of quality PVC Schedule 40 pressure fittings to meet most residential, commercial, industrial and irrigation needs.



TUBE & PIPE

METAL FITTINGS
& NIPPLES

PLASTIC
FITTINGS

VALVES

FILTER-DRYERS
& STRAINERS

TEE

PVC SCHEDULE 40



CONNECTION- SLIP x SLIP x SLIP

Part Number	Size	Inner/Master Carton Qty	Master Weight (lbs.)
401-005	1/2"	50/400	17.4
401-007	3/4"	50/300	4.5
401-010	1"	NA/50	7.4
401-012	1-1/4"	NA/25	5.63
401-015	1-1/2"	NA/25	7.58
401-020	2"	NA/20	11.2
401-025	2-1/2"	NA/10	10
401-030	3"	NA/10	13.74
401-040	4"	NA/5	13.74
401-060	6"	NA/4	34.68

REDUCING

401-095	3/4" x 1/2" x 3/4"	50/300	4
401-101	3/4" x 3/4" x 1/2"	50/300	3.8
401-130	1" x 1" x 1/2"	NA/50	1.37
401-131	1" x 1" x 3/4"	NA/50	1.49
401-167	1-1/4" x 1-1/4" x 3/4"	NA/25	2.2
401-168	1-1/4" x 1-1/4" x 1"	NA/25	2.2
401-210	1-1/2" x 1-1/2" x 3/4"	NA/25	3.91
401-211	1-1/2" x 1-1/2" x 1"	NA/25	3.91
401-251	2" x 2" x 1-1/2"	NA/20	3.84



TEE**PVC SCHEDULE 40****CONNECTION- SLIP x SLIP**

Part Number	Size	Inner/Master Carton Qty	Master Weight (lbs.)
402-005	1/2"	50/300	18
402-007	3/4"	50/300	5
402-010	1"	NA/50	9
402-012	1-1/4"	NA/25	6.5
402-015	1-1/2"	NA/25	9

REDUCING

402-101	3/4" x 3/4" x 1/2"	50/300	4.3
402-130	1" x 1" x 1/2"	NA/50	6
402-131	1" x 1" x 3/4"	NA/50	6.5
402-166	1-1/4" x 1-1/4" x 1/2"	NA/25	8
402-167	1-1/4" x 1-1/4" x 3/4"	NA/25	5.4
402-209	1-1/2" x 1-1/2" x 1/2"	NA/25	7
402-210	1-1/2" x 1-1/2" x 3/4"	NA/25	7.44
402-248	2" x 2" x 3/4"	NA/20	4.2
402-338	3" x 3" x 2"	NA/10	11.3

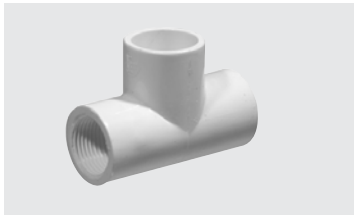
TEE**PVC SCHEDULE 40****CONNECTION- SLIP x FPT x SLIP**

Part Number	Size	Inner/Master Carton Qty	Master Weight (lbs.)
403-007	3/4" x 3/4" x 3/4"	50/300	30.54

TEE**PVC SCHEDULE 40****CONNECTION- FPT x FPT x FPT**

Part Number	Size	Inner/Master Carton Qty	Master Weight (lbs.)
405-005	1/2"	50/400	4.5
405-007	3/4"	50/300	5.5
405-010	1"	NA/50	10

TUBE & PIPE

METAL FITTINGS & NIPPLES

PLASTIC FITTINGS

VALVES

FILTER-DRIERS & STRAINERS



90° ELBOW

PVC SCHEDULE 40



CONNECTION- SLIP x SLIP

Part Number	Size	Inner/Master Carton Qty	Master Weight (lbs.)
406-005	1/2"	50/600	18.8
406-007	3/4"	50/400	22.2
406-010	1"	NA/50	5.9
406-012	1-1/4"	NA/25	4.5
406-015	1-1/2"	NA/25	6.0
406-020	2"	NA/25	9.3
406-025	2-1/2"	NA/10	7.7
406-030	3"	NA/10	11
406-040	4"	NA/5	14.3
406-060	6"	NA/5	32

REDUCING

406-101	3/4" x 1/2"	50/400	2.85
406-130	1" x 1/2"	NA/50	4.33
406-131	1" x 3/4"	NA/50	5
406-168	1-1/4" x 1"	NA/25	3.8

90° ELBOW

PVC SCHEDULE 40



CONNECTION- SLIP x FPT

Part Number	Size	Inner/Master Carton Qty	Master Weight (lbs.)
407-005	1/2"	50/600	20
407-007	3/4"	50/400	24
407-010	1"	NA/50	9.5
407-012	1-1/4"	NA/25	7.5
407-015	1-1/2"	NA/25	9.75
407-020	2"	NA/25	3.7

REDUCING

407-101	3/4" x 1/2"	50/400	21
407-130	1" x 1/2"	NA/50	5
407-131	1" x 3/4"	NA/50	5.5
407-251	2" x 1-1/2"	NA/20	7.5

90° ELBOW

PVC SCHEDULE 40



CONNECTION- FPT x FPT

Part Number	Size	Inner/Master Carton Qty	Master Weight (lbs.)
408-005	1/2"	50/600	28
408-007	3/4"	50/400	4.5

90° ELBOW • STREET

PVC SCHEDULE 40



CONNECTION- SLIP x SP

Part Number	Size	Inner/Master Carton Qty	Master Weight (lbs.)
409-005	1/2"	50/600	16
409-007	3/4"	50/400	5
409-010	1"	NA/50	5.5
409-012	1-1/4"	NA/25	5
409-015	1-1/2"	NA/25	6.5
409-020	2"	NA/20	3.8

90° ELBOW • STREET

PVC SCHEDULE 40



CONNECTION- SLIP x MTP

Part Number	Size	Inner/Master Carton Qty	Master Weight (lbs.)
410-005	1/2"	50/600	16
410-007	3/4"	50/400	5
410-010	1"	NA/50	5.5
410-012	1-1/4"	NA/25	5
410-015	1-1/2"	NA/25	6.5
410-020	2"	NA/20	3.6

90° ELBOW • STREET

PVC SCHEDULE 40



CONNECTION- MIPT x FIPT

Part Number	Size	Inner/Master Carton Qty	Master Weight (lbs.)
412-005	1/2"	50/600	19.6
412-007	3/4"	50/400	5.25
412-010	1"	50/300	8.45

90° ELBOW

PVC SCHEDULE 40



CONNECTION- MIPT x FIPT

Part Number	Size	Inner/Master Carton Qty	Master Weight (lbs.)
414-005	1/2"	NA/50	3
414-101	3/4" x 3/4" x 1/2"	NA/50	4
414-130	1" x 1" x 1/2"	NA/50	6.4

TUBE & PIPE

METAL FITTINGS & NIPPLES

PLASTIC FITTINGS

VALVES

FILTER-DRIERS & STRAINERS



45° ELBOW**PVC SCHEDULE 40****CONNECTION- SLIP x SLIP**

Part Number	Size	Inner/Master Carton Qty	Master Weight (lbs.)
417-005	1/2"	50/600	15.2
417-007	3/4"	50/400	17.4
417-010	1"	NA/50	4.35
417-012	1-1/4"	25/150	3.15
417-015	1-1/2"	NA/25	4.35
417-020	2"	NA/20	6.75
417-025	2-1/2"	NA/10	5.9
417-030	3"	NA/10	8.6
417-040	4"	NA/5	6.6
417-060	6"	NA/5	40

CROSS**PVC SCHEDULE 40****CONNECTION- SLIP x SLIP x SLIP x SLIP**

Part Number	Size	Inner/Master Carton Qty	Master Weight (lbs.)
420-005*	1/2"	50/300	4
420-007*	3/4"	NA/50	5
420-010*	1"	NA/50	9.5
420-012*	1-1/4"	NA/25	11
420-015*	1-1/2"	NA/25	11
420-020*	2"	NA/10	6.5

COUPLING**PVC SCHEDULE 40****CONNECTION- SLIP x SLIP**

Part Number	Size	Inner/Master Carton Qty	Master Weight (lbs.)
429-005	1/2"	50/400	17.4
429-007	3/4"	50/600	18.4
429-010	1"	50/300	3.35
429-012	1-1/4"	25/200	14.55
429-015	1-1/2"	25/150	3.25
429-020	2"	NA/20	4.65
429-025	2-1/2"	NA/10	4.9
429-030	3"	NA/15	6.3
429-040	4"	NA/5	6.84
429-060	6"	NA/5	10.36

REDUCING

429-101	3/4" x 1/2"	50/600	27
429-131	1" x 3/4"	50/200	13.6
429-338	3" x 2"	5/30	15.4
429-422	4" x 3"	NA/4	4.84

COUPLING • THREADED

PVC SCHEDULE 40



CONNECTION- FTP x FTP

Part Number	Size	Inner/Master Carton Qty	Master Weight (lbs.)
430-005	1/2"	50/400	24
430-007	3/4"	50/600	24
430-010	1"	50/300	4.5

RISER • EXTENDER

PVC SCHEDULE 40



CONNECTION- FTP x MTP

Part Number	Size	Inner/Master Carton Qty	Master Weight (lbs.)
434-005	1/2"	50/400	15.9

ADAPTER • FEMALE

PVC SCHEDULE 40



CONNECTION- SLIP x FTP

Part Number	Size	Inner/Master Carton Qty	Master Weight (lbs.)
435-005	1/2"	50/400	18
435-007	3/4"	50/600	18.8
435-010	1"	50/300	4
435-012	1-1/4"	25/200	2.63
435-015	1-1/2"	25/150	3.4
435-020	2"	—/20	1.81
SLIP x REDUCING FPT			
435-101	3/4" x 1/2"	50/600	24
435-131	3/4" x 3/4"	50/200	3.5
SLIP x REDUCING SLIP			
435-074	3/4" x 1/2"	50/600	22.4
435-102	1" x 3/4"	50/200	3.5

TUBE & PIPE

METAL FITTINGS & NIPPLES

PLASTIC FITTINGS

VALVES

FILTER-DRIERS & STRAINERS



ADAPTER • MALE

PVC SCHEDULE 40



CONNECTION- SLIP x MPT

Part Number	Size	Inner/Master Carton Qty	Master Weight (lbs.)
436-005	1/2"	50/800	7.8
436-007	3/4"	50/600	16.8
436-010	1"	50/400	19.8
436-012	1-1/4"	25/200	2.48
436-015	1-1/2"	25/150	2.18
436-020	2"	10/120	4.34

SLIP x REDUCING MPT

436-074	3/4" x 1/2"	50/600	8
436-102	1" x 3/4"	50/400	3.5
436-132	1-1/4" x 1"	25/200	5.
436-169	1-1/2" x 1-1/4"	25/150	20.3
436-213	2" x 1-1/2"	10/120	4.75

MPT x REDUCING SLIP

436-101	3/4" x 1/2"	50/400	9
436-131	1" x 3/4"	50/400	2.4
436-212	1-1/2" x 1-1/4"	25/200	3
436-251	2" x 1-1/2"	10/120	14.4

BUSHING

PVC SCHEDULE 40



CONNECTION- SLIP x SLIP

Part Number	Size	Inner/Master Carton Qty	Master Weight (lbs.)
437-101	3/4" x 1/2"	50/400	6.3
437-130	1" x 1/2"	50/800	9.2
437-131	1" x 3/4"	50/800	6.6
437-166	1-1/4" x 1/2"	25/200	18
437-167	1-1/4" x 3/4"	25/200	23.4
437-168	1-1/4" x 1"	25/200	18.3
437-209	1-1/2" x 1/2"	25/300	28
437-210	1-1/2" x 3/4"	25/300	21
437-211	1-1/2" x 1"	25/300	22
437-212	1-1/2" x 1-1/4"	25/300	12.6
437-248	2" x 3/4"	10/160	12.8
437-249	2" x 1"	10/160	12.32
437-250	2" x 1-1/4"	10/160	12.48
437-251	2" x 1-1/2"	10/160	3.25
437-290	2-1/2" x 1-1/4"	10/80	4.6
437-291	2-1/2" x 1-1/2"	10/80	3.7
437-292	2-1/2" x 2"	10/80	2.5
437-338	3" x 2"	10/60	4.7
437-339	3" x 2-1/2"	10/60	4.1

BUSHING**PVC SCHEDULE 40****CONNECTION- FTP x SPIG**

Part Number	Size	Inner/Master Carton Qty	Master Weight (lbs.)
438-101	3/4" x 1/2"	50/400	7.2
438-130	1" x 1/2"	50/800	10.2
438-131	1" x 3/4"	50/800	8
438-166	1-1/4" x 1/2"	25/200	11
438-167	1-1/4" x 3/4"	25/200	9
438-168	1-1/4" x 1"	25/200	7
438-209	1-1/2" x 1/2"	25/300	11
438-210	1-1/2" x 3/4"	25/300	12
438-211	1-1/2" x 1"	25/300	11.8
438-212	1-1/2" x 1-1/4"	25/300	8
438-247	2" x 1/2"	10/160	13.6
438-248	2" x 3/4"	10/160	14.4
438-249	2" x 1"	10/160	17.6
438-250	2" x 1-1/4"	10/160	16
438-251	2" x 1-1/2"	10/160	12
438-290	2-1/2" x 1-1/4"	10/80	4.8
438-292	2-1/2" x 2"	10/80	2.6
438-338	3" x 2"	10/60	4.7
438-339	3" x 2-1/2"	10/60	4.2
438-421	4" x 2-1/2"	5/30	6.24
438-422	4" x 3"	5/30	4.86

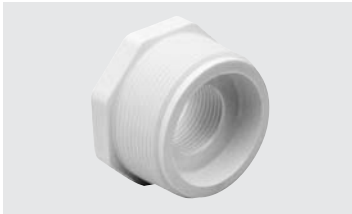
BUSHING**PVC SCHEDULE 40****CONNECTION- FTP x MTP**

Part Number	Size	Inner/Master Carton Qty	Master Weight (lbs.)
439-101	3/4" x 1/2"	50/400	18
439-130	1" x 1/2"	50/800	16
439-131	1" x 3/4"	50/800	16
439-167	1-1/4" x 3/4"	25/200	16.8
439-168	1-1/4" x 1"	25/200	10.5
439-210	1-1/2" x 3/4"	25/200	14
439-211	1-1/2" x 1"	25/200	12
439-212	1-1/2" x 1-1/4"	25/200	7
439-249	2" x 1"	10/160	23
439-251	2" x 1-1/2"	10/120	15.6

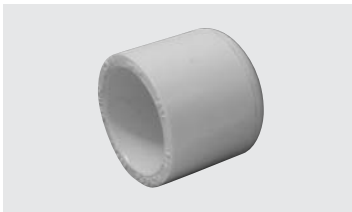
CAP**PVC SCHEDULE 40****CONNECTION- SLIP**

Part Number	Size	Inner/Master Carton Qty	Master Weight (lbs.)
447-005	1/2"	50/400	6.3
447-007	3/4"	50/400	9.9
447-010	1"	50/400	9.2
447-012	1-1/4"	25/300	7
447-015	1-1/2"	25/200	2.6
447-020	2"	10/120	12

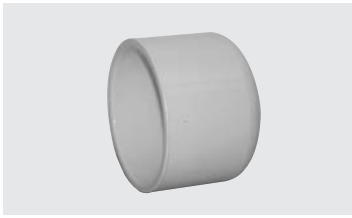
CAP continued**PVC SCHEDULE 40****CONNECTION- SLIP**

Part Number	Size	Inner/Master Carton Qty	Master Weight (lbs.)
447-025	2-1/2"	10/60	3.7
447-030	3"	10/60	5.8
447-040	4"	NA/5	4.1
447-060	6"	NA/5	16

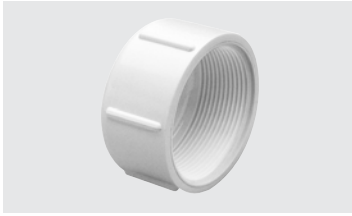
CAP**PVC SCHEDULE 40****CONNECTION- FTP**

Part Number	Size	Inner/Master Carton Qty	Master Weight (lbs.)
448-005	1/2"	50/400	6
448-007	3/4"	50/400	9
448-010	1"	50/400	12
448-012	1-1/4"	25/300	11
448-015	1-1/2"	25/200	14
448-020	2"	10/120	2.1

PLUG**PVC SCHEDULE 40****CONNECTION- SPIG**

Part Number	Size	Inner/Master Carton Qty	Master Weight (lbs.)
449-005	1/2"	50/400	6
449-007	3/4"	50/400	9
449-010	1"	50/800	10
449-012	1-1/4"	25/200	9
449-015	1-1/2"	25/300	10
449-020	2"	10/160	20

PLUG • THREADED**PVC SCHEDULE 40****CONNECTION- MPT**

Part Number	Size	Inner/Master Carton Qty	Master Weight (lbs.)
450-005	1/2"	50/400	6
450-007	3/4"	50/400	6
450-010	1"	50/800	16
450-012	1-1/4"	25/200	15
450-015	1-1/2"	25/200	9
450-020	2"	10/160	16.8

UNION • WITH BUNA O-RING

PVC SCHEDULE 40



CONNECTION- S x S

Part Number	Size	Inner/Master Carton Qty	Master Weight (lbs.)
457-007*	3/4"	10/80	45.8

COUPLING • DEEP SOCKET

PVC SCHEDULE 40

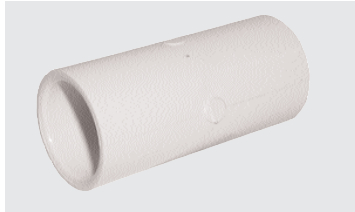

CONNECTION- SLIP

Part Number	Size	Inner/Master Carton Qty	Master Weight (lbs.)
482-007	3/4"	NA/50	2.31

R-TRAP • CONDENSATE DRAIN LINE

PVC SCHEDULE 40

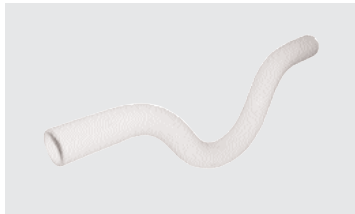

CONNECTION- SP x SP

Part Number	Size	Inner/Master Carton Qty	Master Weight (lbs.)
488-005	1/2"	NA/50	6.
488-007	3/4"	NA/50	12
488-010	1"	NA/10	4

P-TRAP • CONDENSATE DRAIN LINE

PVC SCHEDULE 40



CONNECTION- SP x SP

Part Number	Size	Inner/Master Carton Qty	Master Weight (lbs.)
489-007	3/4"	NA/50	12
489-005*	1/2"	NA/50	6
489-010	1"	NA/10	4

*315PSI

TUBE & PIPE

METAL FITTINGS & NIPPLES

PLASTIC FITTINGS

VALVES

FILTER-DRIERS & STRAINERS



Insert Fittings



TUBE & PIPE

METAL FITTINGS
& NIPPLES

PLASTIC
FITTINGS

VALVES

FILTER-DRIVERS
& STRAINERS

Mueller offers a variety of insert fittings in four different materials; PVC, Nylon, Polypropylene and Steel. These insert fittings are designed to be used in conjunction with clamps and compression fittings for the connection of flexible polyethylene plastic tubing and hosing. Just as with polyethylene tubing, these fittings are for cold water applications only. Polyethylene plastic tubing comes in long coils, requires support every 32 inches and is often subject to kinking if bent too far. Utilizing reliable Mueller Insert Fittings helps to ease the installation of flexible tubing or hosing systems. When the job requires a variety of insert fittings for polyethylene tubing, think Mueller!



ADAPTER

INSERT



*Furnished in either polypropylene or PVC material, whichever is available at time of shipment.

CONNECTION- MIP x MIPT

Part Number	Size	Inner/Master Carton Qty	Master Weight (lbs.)
04784	1/2"	25/900	.02
04785	3/4"	15/360	.03
04786	1"	10/260	.05
04787*	1-1/4"	10/150	.11
04788*	1-1/2"	10/10	.13
04789*	2"	10/60	.17

REDUCING

57562	1/2"	NA/25	.23
57559	3/4"	NA/25	.24
57561	1"	NA/20	.41
57563	1-1/4"	NA/20	.67
57565	1-1/2"	NA/10	.91

ADAPTER

INSERT



CONNECTION- MIP x MIPT

Part Number	Size	Inner/Master Carton Qty	Master Weight (lbs.)
04180	1/2"	25/1,200	.02
04181	3/4"	25/700	.02
04182	1"	25/350	.04
04183	1-1/4"	10/150	.06
04184	1-1/2"	10/140	.08
04185	2"	5/60	.13



ADAPTER continued

INSERT

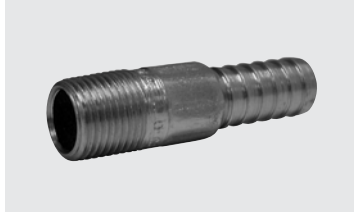

*Furnished in either polypropylene or PVC material, whichever is available at time of shipment.

CONNECTION- MIP x MIPT

Part Number	Size	Inner/Master Carton Qty	Master Weight (lbs.)
04403*	3"	NA/10	.41
NYLON			
04130	1/2"	25/1,200	.02
04131	3/4"	25/700	.03
04132	1"	25/350	.05
04133	1-1/4"	10/150	.08
04134	1-1/2"	10/140	.10
04135	2"	5/60	.18
STEEL			
57541	1/2"	25/300	.14
57543	3/4"	25/200	.22
57545	1"	20/160	.38
57547	1-1/4"	20/120	.55
57549	1-1/2"	10/60	.71
57551	2"	10/40	.95
57556	2-1/2"	NA/1	2.05
57558	3"	NA/1	2.61
57560	4"	NA/1	4.12
PVC			
04306*	1/2" x 3/4"	20/720	.03
04307*	3/4" x 1"	10/400	.07
04308	1" x 1-1/4"	10/160	.08
04309*	1-1/4" x 1-1/2"	5/150	.08
04310*	1-1/2" x 2"	NA/10	.12

ADAPTER

INSERT



CONNECTION- MIP x MIPT

Part Number	Size	Inner/Master Carton Qty	Master Weight (lbs.)
04313*	3/4" x 1/2"	10/450	.04
04314*	1" x 3/4"	10/250	.05
04315*	1-1/4" x 1"	10/120	.07

BUSHING

INSERT



CONNECTION- FIP x MIPT

Part Number	Size	Inner/Master Carton Qty	Master Weight (lbs.)
04202	3/4" x 1/2"	25/1,200	.25
04203	1" x 3/4"	25/800	.02
04204	1-1/4" x 1"	25/500	.25
04205	1-1/2" x 1-1/4"	25/450	.03
04206	2" x 1-1/2"	10/200	.07

COUPLING

INSERT



*Furnished in either polypropylene or PVC material, whichever is available at time of shipment.

**Not listed with NSF.

CONNECTION- INSERT

Part Number	Size	Inner/Master Carton Qty	Master Weight (lbs.)
POLY			
04170	1/2"	10/800	.02
04171	3/4"	10/450	.03
04172*	1"	10/200	.05
04173*	**1-1/4"	10/120	.09
04174	1-1/2"	10/100	.11
04175	2"	5/60	.24
NYLON			
04120	1/2"	10/800	.05
04121	3/4"	10/450	.08
04122**	1"	10/200	.10
04123**	1-1/4"	10/120	.17
04124	1-1/2"	10/100	.23
04125	2"	5/40	.39

90° ELBOW

INSERT



*Furnished in either polypropylene or PVC material, whichever is available at time of shipment.

CONNECTION- INSERT

Part Number	Size	Inner/Master Carton Qty	Master Weight (lbs.)
POLY PLUS			
04177	1/2"	10/300	.05
04179	3/4"	25/450	.08
04333*	1"	NA/25	.10
04337*	1-1/4"	NA/10	.17
04339*	1-1/2"	NA/10	.23
04341*	2"	5/40	.39
NYLON			
04176	3/4" x 1/2"	10/240	.05
04331*	1" x 1/2"	10/180	.09
04332*	x 3/4"	10/180	.09
04334*	1-1/4" x 1/2"	NA/25	.10
04335*	1-1/4" x 3/4"	NA/10	.11
04336*	1-1/4" x 1"	5/150	.14
04338*	1-1/2" x 1-1/4"	NA/10	.21
04340*	2" x 1-1/2"	5/40	.31

90° CAP

INSERT



*Furnished in either polypropylene or PVC material, whichever is available at time of shipment.

CONNECTION- INSERT

Part Number	Size	Inner/Master Carton Qty	Master Weight (lbs.)
REDUCING			
04342*	1/2"	10/600	.03
04343*	3/4"	10/400	.05
04344*	1"	10/240	.07
04345*	1-1/4"	5/140	.12
04346*	1-1/2"	5/75	.18
04347*	2"	5/60	.30

ABS DWV Fittings



Mueller's ABS DWV fittings are made to the most exacting specifications to ensure the best fit in the industry. Each fitting offers excellent rigidity, corrosion and chemical resistance while smooth walls prevent scaling and provide for free flow. Our precise manufacturing processes and stringent quality control ensure that our fittings perform flawlessly piece after piece. Fittings are packaged to common industry carton quantities and dimensions plus utilize an intuitive, recognizable style number system.

- Meets ASTM standard D2661 and D3311
- Made in the USA



TUBE & PIPE

METAL FITTINGS & NIPPLES

PLASTIC FITTINGS

VALVES

FILTER-DRIERS & STRAINERS

COUPLING

ABS DWV

A100

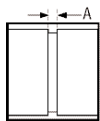
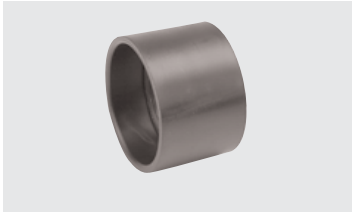

CONNECTION H x H	CHARLOTTE STYLE 100			NIBCO STYLE 5801		Dimensions				
	Part Number	Ctn Qty	Approx Net Wt.	A	B	C	D	E	F	
1-1/4"	02932	50	.06	1/8						
1-1/2"	02933	100	.07	1/8						
2"	02934	100	.10	1/8						
3"	02935	60	.33	3/16						
4"	02936	25	.58	1/4						
6"	03143	15	1.45	1/4						

ADAPTER • FEMALE

ABS DWV

A101

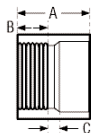
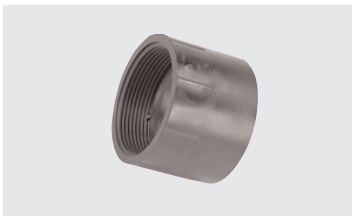

CONNECTION H x FPT	CHARLOTTE STYLE 101			NIBCO STYLE 5803		Dimensions				
	Part Number	Ctn Qty	Approx Net Wt.	A	B	C	D	E	F	
1-1/4"	03006	50	.07	1-5/8	15/16	1/4				
1-1/2"	02866	100	.07	1-5/8	15/16	1/4				
2"	02867	100	.11	1-7/8	1	1/4				
3"	02869	30	.37	3-1/32	1-27/32	5/16				
4"	03396	10	.58	3-3/32	1-5/16	11/32				
6"	03147	10	1.40	4-3/4	1-3/4	1/4				



PIPE INCREASER • REDUCER

ABS DWV

A102

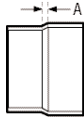
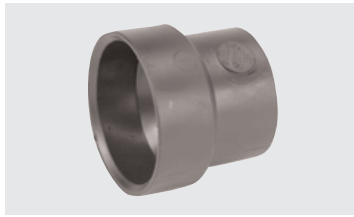

CONNECTION H x H	CHARLOTTE STYLE 102		NIBCO STYLE N/A							
	Part Number	Ctn Qty	Approx Net Wt.	Dimensions						
Size	A	B	C	D	E	F				
2" x 1-1/2"	02948	25	.11	17/32						
3" x 1-1/2"	02949	50	.30	17/16						
3" x 2"	02950	20	.30	7/8						
4" x 2"	02951	10	.51	1-3/8						
4" x 3"	02952	20	.58	5/8						

TRAP ADAPTER • MALE • W/ONE-PIECE POLY NUT

ABS DWV

A103P

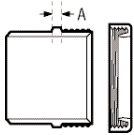

CONNECTION SP x SJ	CHARLOTTE STYLE 103-P		NIBCO STYLE N/A							
	Part Number	Ctn Qty	Approx Net Wt.	Dimensions						
Size	A	B	C	D	E	F				
1-1/4"	03391	50	.08	3/16						
1-1/2"	03393	50	.09	3/16						
1-1/2" x 1-1/4"	03379	75	.09	3/16						

TRAP ADAPTER • MALE • W/PLASTIC NUT & 1-1/2" & 1-1/4" WASHERS

ABS DWV

A103R

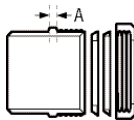

CONNECTION SP x SJ	CHARLOTTE STYLE N/A		NIBCO STYLE N/A							
	Part Number	Ctn Qty	Approx Net Wt.	Dimensions						
Size	A	B	C	D	E	F				
1-1/2" x 1-1/4"	03389	50	.10	3/16						
OR 1-1/2"	03389	50	.10	3/16						

TRAP ADAPTER • MALE • W/PLASTIC NUT & WASHER

ABS DWV

A103W

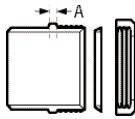

CONNECTION SP x SJ	CHARLOTTE STYLE N/A	NIBCO STYLE 5801-2-7	Dimensions						
Size	Part Number	Ctn Qty	Approx Net Wt.	A	B	C	D	E	F
1-1/4"	03308	50	.08	3/16					
1-1/2"	03410	50	.09	3/16					
2"	03390	25	.12	3/16					
1-1/2" x 1-1/4"	03409	50	.09	3/16					

TRAP ADAPTER • MALE • W/CHROME NUT & WASHER

ABS DWV

A103X

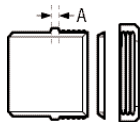

CONNECTION SP x SJ	CHARLOTTE STYLE 103X	NIBCO STYLE 5801-2-7-C	Dimensions						
Size	Part Number	Ctn Qty	Approx Net Wt.	A	B	C	D	E	F
1-1/4"	03309	50	.14	3/16					
1-1/2"	03392	50	.15	3/16					
1-1/2" x 1-1/4"	03378	100	.13	3/16					

TRAP ADAPTER • FEMALE • W/ONE-PIECE POLY NUT

ABS DWV

A104P

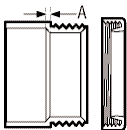

CONNECTION H x SJ	CHARLOTTE STYLE 104-P	NIBCO STYLE N/A	Dimensions						
Size	Part Number	Ctn Qty	Approx Net Wt.	A	B	C	D	E	F
1-1/4"	03381	50	.08	3/16					
1-1/2"	03377	50	.09	3/16					
1-1/2" x 1-1/4"	03395	50	.11	3/16					

TRAP ADAPTER • FEMALE • W/PLASTIC NUT & WASHER

ABS DWV

A104W

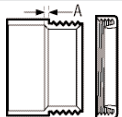

CONNECTION H x SJ	CHARLOTTE STYLE N/A	NIBCO STYLE 5801-7	Dimensions						
Size	Part Number	Ctn Qty	Approx Net Wt.	A	B	C	D	E	F
1-1/4"	03380	50	.11	3/16					
1-1/2"	03383	50	.09	3/16					
2"	03382	25	.13	3/16					
1-1/2" x 1-1/4"	03384	50	.10	3/16					

TUBE & PIPE

METAL FITTINGS & NIPPLES

PLASTIC FITTINGS

VALVES

FILTER-DRIERS & STRAINERS



TRAP ADAPTER • FEMALE W/CHROME NUT & WASHER

ABS DWV

A104X

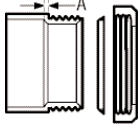

CONNECTION H x SJ	CHARLOTTE STYLE 104-X	NIBCO STYLE 5801-7-C		Dimensions					
Size	Part Number	Ctn Qty	Approx Net Wt.	A	B	C	D	E	F
1-1/2"	03376	50	.15	3/16					
2"	03397	25	.21	3/16					
1-1/2" x 1-1/4"	03394	50	.13	3/16					

ADAPTER • CLEANOUT

ABS DWV

A105

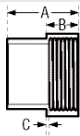

CONNECTION SP x FPT	CHARLOTTE STYLE 105	NIBCO STYLE 5803-2		Dimensions					
Size	Part Number	Ctn Qty	Approx Net Wt.	A	B	C	D	E	F
1-1/4"	02921	50	.06	1-19/32	27/32	5/32			
1-1/2"	02922	50	.07	1-5/8	7/8	5/32			
2"	02923	50	.09	1-17/32	29/32	5/32			
3"	02924	25	.34	2-29/32	1-13/64	3/16			
4"	02925	10	.53	3-13/32	1-5/16	1/4			
6"	03148	10	1.13	4-7/8	1-7/8	3/8			

ADAPTER • CLEANOUT • W/CLEANOUT PLUG

ABS DWV

A105X

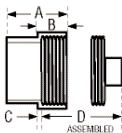

CONNECTION SP x FPT	CHARLOTTE STYLE 105-X	NIBCO STYLE 5816		Dimensions					
Size	Part Number	Ctn Qty	Approx Net Wt.	A	B	C	D	E	F
1-1/2"	03001	50	.11	1-5/8	7/8	5/32	1-15/32		
2"	03002	50	.15	1-17/32	29/32	5/32	1-1/2		
3"	03003	25	.41	2-29/32	1-13/64	3/16	2-1/64		
4"	03004	10	.67	3-13/32	1-5/16	1/4	2-1/16		
6"	03005	10	1.81	4-7/8	1-7/8	3/8	2-1/2		

PLUG • CLEANOUT

ABS DWV

A106



CONNECTION MPT	CHARLOTTE STYLE 106	NIBCO STYLE 5818		Dimensions					
Size	Part Number	Ctn Qty	Approx Net Wt.	A	B	C	D	E	F
1-1/2"	02938	50	.05	5/8	1-3/8				
2"	02939	50	.07	5/8	1-3/8				
3"	02941	25	.14	3/4	1-3/4				
3-1/2"	02943	30	.18	3/4	1-3/4				
4"	02942	30	.26	7/8	1-7/8				
6"	03146	10	.54	1	2				

PLUG • SLIP

ABS DWV

A106P

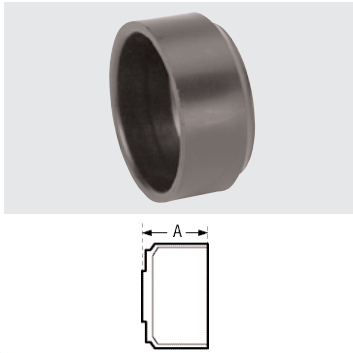

Size	CONNECTION SP	CHARLOTTE STYLE N/A		NIBCO STYLE 5826		Dimensions				
		Part Number	Ctn Qty	Approx Net Wt.	A	B	C	D	E	F
1-1/2"		03055	25	.05	1-1/16					
2"		03056	50	.06	1-1/8					

BUSHING • FLUSH

ABS DWV

(STYLE #3)

A107

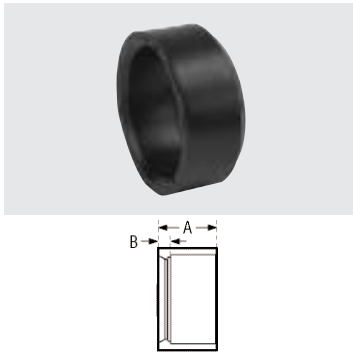

Size	CONNECTION SP x H	CHARLOTTE STYLE 107		NIBCO STYLE 5801-2-F		Dimensions				
		Part Number	Ctn Qty	Approx Net Wt.	A	B	C	D	E	F
1-1/2" x 1-1/4"		02904	100	.04	1	3/16				
2" x 1-1/4"		02905	50	.10	1 1/16	5/16				
2" x 1-1/2"		02906	50	.08	1 1/16	5/16				
3" x 1-1/2"		02907	30	.26	1-1/2	7/8				
3" x 2"		02908	30	.26	1-1/2	3/4				
4" x 2"		02910	30	.45	2	1/4				
4" x 3"		02909	30	.34	1-3/4	1/4				

BUSHING • FLANGE • W/TUBE STOP

ABS DWV

(STYLE #1)

A107S

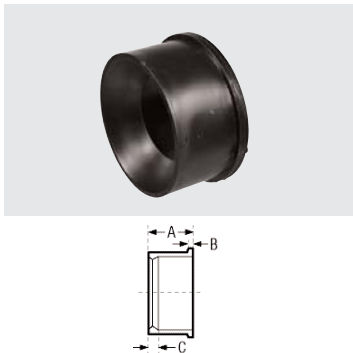

Size	CONNECTION SP x H	CHARLOTTE STYLE N/A		NIBCO STYLE N/A		Dimensions				
		Part Number	Ctn Qty	Approx Net Wt.	A	B	C	D	E	F
6" x 4"		03144	10	1.41	3-1/2	1/2	1-3/4			

BUSHING • FLUSH (CLEANOUT ADAPTER)

ABS DWV

(STYLE #3)

A108



Size	CONNECTION SP x FPT	CHARLOTTE STYLE N/A		NIBCO STYLE N/A		Dimensions				
		Part Number	Ctn Qty	Approx Net Wt.	A	B	C	D	E	F
1-1/2" x 1-1/4"		02912	50	.04	1					
2" x 1-1/2"		02913	50	.08	1 3/32					

TUBE & PIPE

METAL FITTINGS & NIPPLES

PLASTIC FITTINGS

VALVES

FILTER-DRIERS & STRAINERS



ADAPTER • MALE

ABS DWV

A109

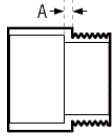

CONNECTION H x MPT	CHARLOTTE STYLE 109			NIBCO STYLE 5804		Dimensions					
	Part Number	Ctn Qty	Approx Net Wt.	A	B	C	D	E	F		
1-1/4"	02931	50	.05	3/16							
1-1/2"	02927	50	.06	3/16							
2"	02928	50	.10	3/16							
3"	02929	25	.33	3/8							
4"	02930	10	.45	3/8							
1-1/2" x 1-1/4"	02926	25	.07	3/16							

ADAPTER • MALE

ABS DWV

A111

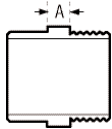

CONNECTION SP x MPT	CHARLOTTE STYLE 111			NIBCO STYLE 5804-2		Dimensions					
	Part Number	Ctn Qty	Approx Net Wt.	A	B	C	D	E	F		
1-1/4"	03010	50	.06	5/32							
1-1/2"	03386	50	.07	5/32							
2"	03385	25	.08	5/32							
3"	03366	25	.28	3/8							

REDUCING

1-1/2" x 1-1/4"	03387	100	.07	5/16						
-----------------	-------	-----	-----	------	--	--	--	--	--	--

ADAPTER • TRAY PLUG

ABS DWV

A113

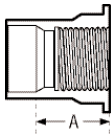
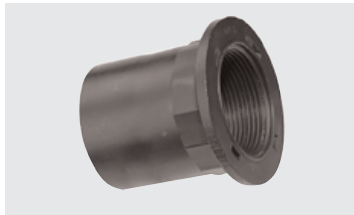

CONNECTION H x NPSM Threaded	CHARLOTTE STYLE N/A			NIBCO STYLE 5803-TPA		Dimensions					
	Part Number	Ctn Qty	Approx Net Wt.	A	B	C	D	E	F		
1-1/2"	03014	50	.15	1-7/8							

ADAPTER • TRAY PLUG • SPIGOT

ABS DWV

A113S

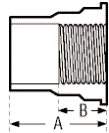

Size	Part Number	Ctn Qty	Approx Net Wt.	Dimensions						
				A	B	C	D	E	F	
1-1/2"	03419	50	.15	3-3/8	1-9/16					

CONNECTION
SP x NPSM Threaded

CHARLOTTE STYLE
N/A

NIBCO STYLE
5803-2-TPA

TUBE & PIPE

METAL FITTINGS & NIPPLES

PLASTIC FITTINGS

VALVES

FILTER-DRIERS & STRAINERS

CAP • THREADED

ABS DWV

A114

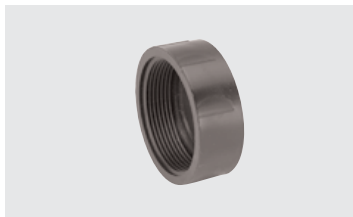

Size	Part Number	Ctn Qty	Approx Net Wt.	Dimensions						
				A	B	C	D	E	F	
1-1/2"	02993	100	.06	7/8						
2"	02994	50	.09	7/8						
3"	02995	25	.27	1-3/8						

CONNECTION
FPT

CHARLOTTE STYLE
114

NIBCO STYLE
5827

CAP • SOCKET

ABS DWV

A116



Size	Part Number	Ctn Qty	Approx Net Wt.	Dimensions						
				A	B	C	D	E	F	
1-1/2"	02977	50	.06	1-1/16						
2"	02978	50	.09	1-3/16						
3"	02979	25	.28	2-1/4						
4"	02980	5	.52	2-5/16						

CONNECTION
H

CHARLOTTE STYLE
116

NIBCO STYLE
5817



ADAPTER • COUPLING**ABS DWV**

(Adapts Sewer & Drain Pipe To DWV Pipe)

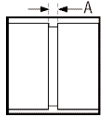
A117CONNECTION
S/D H x DWV HCHARLOTTE STYLE
117NIBCO STYLE
5800-SD

Size	Part Number	Ctn Qty	Approx Net Wt.	Dimensions					
				A	B	C	D	E	F
3"	02970	10	.44	1/8					
4"	02963	10	.43	1/4					
4" x 3"	02962	20	.60	1/4					

ADAPTER • BUSHING (DWV SPIGOT X S/D HUB)**ABS DWV**

(Adapts DWV HUB To S/D SPIGOT)

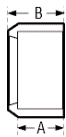
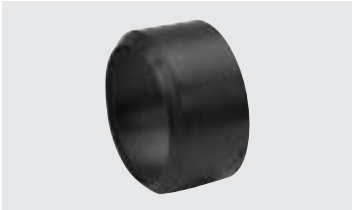
A118CONNECTION
DWV SP x S/D HUBCHARLOTTE STYLE
118NIBCO STYLE
N/A

Size	Part Number	Ctn Qty	Approx Net Wt.	Dimensions					
				A	B	C	D	E	F
3"	02990	25	.09	1-1/2	1-3/4				
4"	02991	10	.15	1-3/4	2				

ADAPTER • NO HUB**ABS DWV**

(Adapts CI No Hub To DWV Pipe)

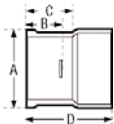
A119CONNECTION
CI NO H x DWV HCHARLOTTE STYLE
119NIBCO STYLE
5805-N

Size	Part Number	Ctn Qty	Approx Net Wt.	Dimensions					
				A	B	C	D	E	F
2"	02954	25	.12	2-3/8	1-1/8	1-5/8	2-1/2		
3"	02955	20	.29	3-3/8	1-1/8	1-7/8	3-3/8		
4"	02956	15	.47	4-7/16	1-1/8	1-15/16	3-11/16		

ADAPTER • HUB • CAST IRON**ABS DWV**

(Adapts CI To DWV Pipe)

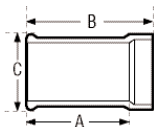
A123CONNECTION
CI SP x DWV HCHARLOTTE STYLE
123NIBCO STYLE
5805

Size	Part Number	Ctn Qty	Approx Net Wt.	Dimensions					
				A	B	C	D	E	F
2"	02957	20	.23	3-1/2	4-3/4	2-3/4			
3"	02958	10	.54	4-1/4	5-7/8	3-3/4			
4"	02959	20	.86	4-7/8	6-5/8	4-3/4			

ADAPTER • HUB • CAST IRON • INCREASER

ABS DWV

(ADAPTS CI HUB TO DWV PIPE) **A123R**

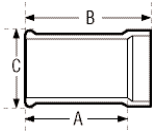

CONNECTION
CI SP x DWV H

CHARLOTTE STYLE
123-R

NIBCO STYLE
5805

Size	Part Number	Ctn Qty	Approx Net Wt.	Dimensions					
				A	B	C	D	E	F
2" x 1-1/2"	02961	20	.21	3-3/8	4-1/8	2-5/8			
3" x 1-1/2"	02964	10	.15	3-9/16	4-7/8	3-5/8			
4" x 3"	02960	10	.78	4	5-3/4	4-3/4			

COUPLING • REPAIR

ABS DWV

A130

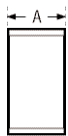

CONNECTION
H x H

CHARLOTTE STYLE
130

NIBCO STYLE
5801-RP

Size	Part Number	Ctn Qty	Approx Net Wt.	Dimensions					
				A	B	C	D	E	F
1-1/2"	02965	20	.06	1-1/2					
2"	02966	20	.09	1-3/4					
3"	02967	20	.32	3					
4"	02968	5	.56	3-1/2					

CAP • TEST • STYRENE

ABS DWV

A131

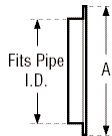

CONNECTION
FITS PIPE I.D.

CHARLOTTE STYLE
131

NIBCO STYLE
5817-P

Size	Part Number	Ctn Qty	Approx Net Wt.	Dimensions					
				A	B	C	D	E	F
1-1/2"	02411	100	.01	1-15/16					
2"	02412	100	.01	2-3/8					
3"	02413	50	.03	3-1/2					
4"	02414	50	.05	4-1/2					

NUT • SLIP JOINT • PLASTIC

ABS DWV

A140



CONNECTION
NPSM THREAD

CHARLOTTE STYLE
N/A

NIBCO STYLE
N/A

Size	Part Number	Ctn Qty	Approx Net Wt.	Dimensions					
				A	B	C	D	E	F
1-1/4"	02743	400	.03	1 1/16					
1-1/2"	02744	100	.03	1 1/16					
2"	02741	100	.38	1 1/16					



WASHER • SLIP JOINT

ABS DWV

A141

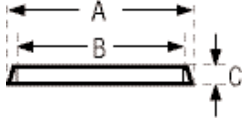

CONNECTION SJ	CHARLOTTE STYLE			NIBCO STYLE			Dimensions			
	Part Number	Ctn Qty	Approx Net Wt.	A	B	C	D	E	F	
1-1/2"	02747	2000	.003	1-47/64	1-1/2	1-3/64				
1-1/2" x 1-1/4"	02748	500	.01	1-23/32	1-1/4	1-7/64				

(For use with 1-1/2 SJ Nut)

NUT • ONE-PIECE POLY

ABS DWV

A142

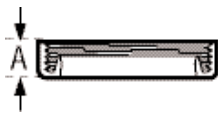

CONNECTION SJ x NPSM	CHARLOTTE STYLE			NIBCO STYLE			Dimensions			
	Part Number	Ctn Qty	Approx Net Wt.	A	B	C	D	E	F	
1-1/4"	01036	150	.023	5/8						
1-1/2"	01038	125	.025	5/8						

ELBOW • 1/4 BEND

ABS DWV

A300

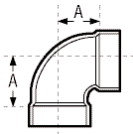

CONNECTION H x H	CHARLOTTE STYLE			NIBCO STYLE			Dimensions			
	Part Number	Ctn Qty	Approx Net Wt.	A	B	C	D	E	F	
1-1/4"	02875	50	.11	1-9/16						
1-1/2"	02876	100	.13	1-3/4						
2"	02877	50	.22	2-5/16						
3"	02878	25	.61	3-1/16						
4"	02879	10	1.12	3-7/8						
6"	03130	3	2.81	5						

ELBOW • 1/4 BEND • REDUCING

ABS DWV

A300R

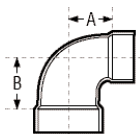

CONNECTION H x H	CHARLOTTE STYLE			NIBCO STYLE			Dimensions			
	Part Number	Ctn Qty	Approx Net Wt.	A	B	C	D	E	F	
2" x 1-1/2"	03092	10	.24	2-5/16	2-7/16					

ELBOW • SIDE INLET • 1/4 BEND

ABS DWV

A300S

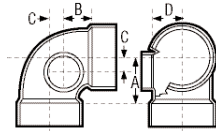

CONNECTION	CHARLOTTE STYLE		NIBCO STYLE		Dimensions					
ALL HUB	300-S		5807-3		A	B	C	D	E	F
Size	Part Number	Ctn Qty	Approx Net Wt.							
3" x 3" x 1-1/2"	03069	10	.79	3-1/16	2-1/16	1	1-7/8			
3" x 3" x 2"	03070	10	.79	3-1/16	2-1/16	1	1-7/8			

ELBOW • STREET • 1/4 BEND

ABS DWV

A302

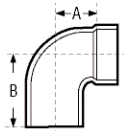

CONNECTION	CHARLOTTE STYLE		NIBCO STYLE		Dimensions					
SP x H	302		5807-2		A	B	C	D	E	F
Size	Part Number	Ctn Qty	Approx Net Wt.							
1-1/4"	02894	50	.12	1-9/16	2-1/4					
1-1/2"	02880	100	.15	1-3/4	2-7/16					
2"	02881	50	.25	2-5/16	3-1/16					
3"	02882	20	.71	3-1/16	4-9/16					
4"	02883	10	1.29	3-7/8	5-5/8					
6"	02889	5	3.32	5	8					

ELBOW • STREET • 1/4 BEND • W/LOW HEEL INLET

ABS DWV

A303

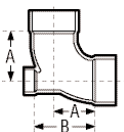

CONNECTION	CHARLOTTE STYLE		NIBCO STYLE		Dimensions					
ALL HUB	303		5861-LH		A	B	C	D	E	F
Size	Part Number	Ctn Qty	Approx Net Wt.							
3" x 3" x 1-1/2"	03041	25	.81	3-1/16	4-1/2					
3" x 3" x 2"	03042	25	.82	3-1/16	4-7/16					
4" x 4" x 2"	03043	15	1.48	3-7/8	5-7/16					

TUBE & PIPE

METAL FITTINGS & NIPPLES

PLASTIC FITTINGS

VALVES

FILTER-DRIERS & STRAINERS



ELBOW • LONG SWEEP • 1/4 BEND

ABS DWV

A304

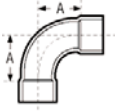

CONNECTION H x H	CHARLOTTE STYLE 304	NIBCO STYLE 5807-LT	Dimensions						
Size	Part Number	Ctn Qty	Approx Net Wt.	A	B	C	D	E	F
1-1/4"	02870	50	.17	2-1/4					
1-1/2"	02871	50	.21	2-3/4					
2"	02872	25	.33	3-1/4					
3"	02873	10	.93	4-1/16					
4"	02874	5	1.60	4-15/16					

ELBOW • LONG SWEEP • 1/4 BEND • W/HIGH INLET

ABS DWV

A305

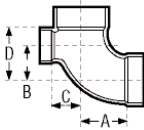

CONNECTION ALL HUB	CHARLOTTE STYLE N/A	NIBCO STYLE 5861	Dimensions						
Size	Part Number	Ctn Qty	Approx Net Wt.	A	B	C	D	E	F
3" x 3" x 1-1/2"	03028	10	.95	4-1/16	2-1/4	1-9/16	3-5/8		
3" x 3" x 2"	03027	25	.96	4-1/16	2-1/4	1-9/16	4-1/16		

ELBOW • LONG SWEEP • 1/4 BEND • W/LOW INLET

ABS DWV

A307

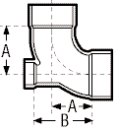

CONNECTION ALL HUB	CHARLOTTE STYLE N/A	NIBCO STYLE N/A	Dimensions						
Size	Part Number	Ctn Qty	Approx Net Wt.	A	B	C	D	E	F
3" x 3" x 1-1/2"	03025	10	.94	4-1/16	4-3/4				
3" x 3" x 2"	03024	25	.97	4-1/16	4-15/16				

ELBOW • LONG SWEEP • 1/4 BEND • STREET

ABS DWV

A309

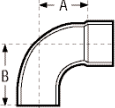

CONNECTION SP x H	CHARLOTTE STYLE 309	NIBCO STYLE 5807-2-LT	Dimensions						
Size	Part Number	Ctn Qty	Approx Net Wt.	A	B	C	D	E	F
1-1/2"	03060	50	.21	2-1/4	2-15/16				
2"	03061	25	.29	3-1/4	4				
3"	03063	20	.89	4-1/16	5-9/16				

ELBOW • 1/4 BEND • W/LOW INLET • STREET

ABS DWV

A310

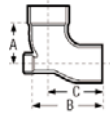

CONNECTION H x SP x H	CHARLOTTE STYLE		NIBCO STYLE		Dimensions					
	310		5861-LH		A	B	C	D	E	F
Size	Part Number	Ctn Qty	Approx Net Wt.							
3" x 3" x 2"	03026	15	.82	3-1/8	5-15/16	4-5/8				

ELBOW • LONG SWEEP • 1/4 BEND • W/SIDE INLET

ABS DWV

A311

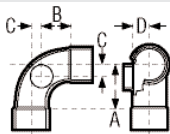

CONNECTION ALL HUB	CHARLOTTE STYLE		NIBCO STYLE		Dimensions					
	N/A		N/A		A	B	C	D	E	F
Size	Part Number	Ctn Qty	Approx Net Wt.							
3" x 3" x 1-1/2"	03051	10	.87	4-1/16	3	1-1/16	2-3/16			
3" x 3" x 2"	03050	25	.93	4-1/16	3	1-1/16	2-3/16			

ELBOW • 1/6 BEND

ABS DWV

A319

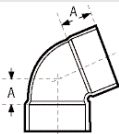

CONNECTION H x H	CHARLOTTE STYLE		NIBCO STYLE		Dimensions					
	319		5860		A	B	C	D	E	F
Size	Part Number	Ctn Qty	Approx Net Wt.							
1-1/2"	02895	50	.11	1/2						
2"	02896	40	.16	1-1/16						
3"	02897	20	.47	1-3/16						
4"	02982	15	.84	1-5/16						
6"	02988	3	3.87	1-7/16						

ELBOW • 1/6 BEND • STREET

ABS DWV

A320

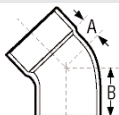

CONNECTION SP x H	CHARLOTTE STYLE		NIBCO STYLE		Dimensions					
	320		5860-2		A	B	C	D	E	F
Size	Part Number	Ctn Qty	Approx Net Wt.							
1-1/2"	03020	40	.12	1	11/16					
2"	03021	25	.19	1-7/16	2-1/16					
3"	03022	20	.57	1-11/16	3-3/16					
4"	03023	5	1.10	2-1/16	3-9/16					



TUBE & PIPE

METAL FITTINGS & NIPPLES

PLASTIC FITTINGS

VALVES

FILTER-DRIERS & STRAINERS

ELBOW • 1/8 BEND

ABS DWV

A321

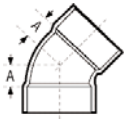

CONNECTION H x H	CHARLOTTE STYLE 321			NIBCO STYLE 5806			Dimensions			
Size	Part Number	Ctn Qty	Approx Net Wt.	A	B	C	D	E	F	
1-1/4"	02884	50	.14	1						
1-1/2"	02885	100	.18	1-1/8						
2"	02886	50	.30	1-1/2						
3"	02887	20	.82	1-3/4						
4"	02888	10	1.50	2-3/16						
6"	02132	3	4.11	2						

ELBOW • 1/8 BEND • STREET

ABS DWV

A323

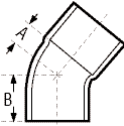

CONNECTION SP x H	CHARLOTTE STYLE 323			NIBCO STYLE 5806-2			Dimensions			
Size	Part Number	Ctn Qty	Approx Net Wt.	A	B	C	D	E	F	
1-1/4"	03016	50	.10	1	1-11/16					
1-1/2"	02890	100	.13	1-1/8	1-13/16					
2"	02891	50	.20	1-1/2	2-1/4					
3"	02892	20	.57	1-3/4	3-1/4					
4"	02893	10	1.02	2-3/16	3-15/16					
6"	03133	3	2.72	2	5					

ELBOW • 1/16 BEND

ABS DWV

A324

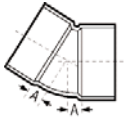

CONNECTION H x H	CHARLOTTE STYLE 324			NIBCO STYLE 5808			Dimensions			
Size	Part Number	Ctn Qty	Approx Net Wt.	A	B	C	D	E	F	
1-1/2"	02899	50	.11	1/2						
2"	02900	25	.16	1-1/16						
3"	02901	20	.47	1-3/16						
4"	02983	15	.84	1-5/16						
6"	02988	3	3.87	1-7/16						

ELBOW • 1/16 BEND • STREET

ABS DWV

A326

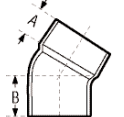

CONNECTION SP x H	CHARLOTTE STYLE 326			NIBCO STYLE 5808-2			Dimensions			
Size	Part Number	Ctn Qty	Approx Net Wt.	A	B	C	D	E	F	
1-1/2"	02984	50	.09	1/2	1-3/16					
2"	02985	25	.15	1-1/16	1-7/16					
3"	02986	20	.44	13/16	2-5/16					
4"	02987	10	.78	1	2-3/4					

ELBOW • DOUBLE • 1/4 BEND

ABS DWV

A327

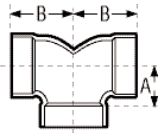

CONNECTION ALL HUB	CHARLOTTE STYLE		NIBCO STYLE		Dimensions					
	Part Number	Ctn Qty	Approx Net Wt.	A	B	C	D	E	F	
	327									
Size										
1-1/2"	03045	20	.19	1-3/4	1-3/4					
2"	03046	25	.33	2-5/16	2-5/16					
3"	03047	10	1.11	3-1/16	3-1/16					
REDUCING										
2" x 1-1/2" x 1-1/2"	03049	25	.23	1-15/16	1-3/4					

ELBOW • CLOSET BEND • REDUCING • SHORT RADIUS

ABS DWV

A328

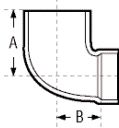

CONNECTION SP x H	CHARLOTTE STYLE		NIBCO STYLE		Dimensions					
	Part Number	Ctn Qty	Approx Net Wt.	A	B	C	D	E	F	
	N/A									
Size										
4" x 3"	03105	10	1.02	5	3-3/8					

ELBOW • CLOSET BEND • REDUCING • SHORT RADIUS • W/TEST CAP

ABS DWV

A328X

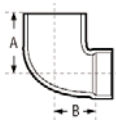

CONNECTION SP x H	CHARLOTTE STYLE		NIBCO STYLE		Dimensions					
	Part Number	Ctn Qty	Approx Net Wt.	A	B	C	D	E	F	
	N/A									
Size										
4" x 3"	03104	10	1.06	5-1/16	3-3/8					

ELBOW • CLOSET BEND • REDUCING

ABS DWV

A329

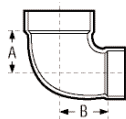

CONNECTION SP x H	CHARLOTTE STYLE		NIBCO STYLE		Dimensions					
	Part Number	Ctn Qty	Approx Net Wt.	A	B	C	D	E	F	
	329									
Size										
4" x 3"	03093	10	.95	3	3-3/8					

TUBE & PIPE

METAL FITTINGS & NIPPLES

PLASTIC FITTINGS

VALVES

FILTER-DRIVERS & STRAINERS



ELBOW • CLOSET BEND • REDUCING • STREET ELBOW

ABS DWV

A330

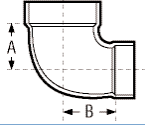
CONNECTION
SP x HCHARLOTTE STYLE
330NIBCO STYLE
5807-2-CL

Size	Part Number	Ctn Qty	Approx Net Wt.	Dimensions					
				A	B	C	D	E	F
4" x 3"	03107	10	1.13	6	3-3/8				

ELBOW • CLOSET BEND • REDUCING • STREET • TEST CAP

ABS DWV

A330X

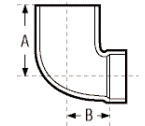
CONNECTION
SP x HCHARLOTTE STYLE
330XNIBCO STYLE
N/A

Size	Part Number	Ctn Qty	Approx Net Wt.	Dimensions					
				A	B	C	D	E	F
4" x 3"	03108	10	1.16	6-1/16	3-3/8				

ELBOW • VENT ELL

ABS DWV

A331

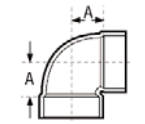
CONNECTION
H x HCHARLOTTE STYLE
331NIBCO STYLE
5807-V

Size	Part Number	Ctn Qty	Approx Net Wt.	Dimensions					
				A	B	C	D	E	F
1-1/4"	03083	20	.11	1					
1-1/2"	03084	20	.15	1-3/16					
2"	03085	30	.21	1-1/2					
3"	03086	25	.66	1-7/8					
4"	03087	10	1.05	2-1/2					

ELBOW • VENT ELL

ABS DWV

A332

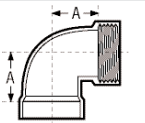
CONNECTION
H x FPTCHARLOTTE STYLE
N/ANIBCO STYLE
5807-3

Size	Part Number	Ctn Qty	Approx Net Wt.	Dimensions					
				A	B	C	D	E	F
3"	03071	20	.65	1-7/8					

ELBOW • VENT ELL • STREET

ABS DWV

A333

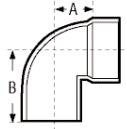
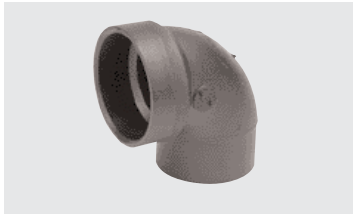

CONNECTION SP x H	CHARLOTTE STYLE 333			NIBCO STYLE 5807-2-V					
	Part Number	Ctn Qty	Approx Net Wt.	Dimensions					
Size				A	B	C	D	E	F
1-1/2"	03088	25	.13	1-3/16	1-7/8				
2"	03089	20	.20	1-1/2	2-1/4				
3"	03090	10	.58	1-9/16	2-5/8				

TEE • SANITARY

ABS DWV

A400

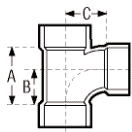

CONNECTION ALL HUB	CHARLOTTE STYLE 400			NIBCO STYLE 5811					
	Part Number	Ctn Qty	Approx Net Wt.	Dimensions					
Size				A	B	C	D	E	F
1-1/4"	02751	50	.17	2-5/16	1-9/16	1-9/16			
1-1/2"	02752	100	.23	2-3/4	1-3/4	1-3/4			
2"	02753	35	.36	3-11/16	2-5/16	2-5/16			
3"	02754	30	1.04	4-7/8	3-1/16	3-1/16			
4"	02755	5	1.81	6-1/8	3-7/8	3-7/8			
6"	02756	5	4.67	8-1/2	5	5			

TEE • SANITARY • REDUCING

ABS DWV

A401

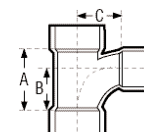

CONNECTION ALL HUB	CHARLOTTE STYLE 401			NIBCO STYLE 5811					
	Part Number	Ctn Qty	Approx Net Wt.	Dimensions					
Size				A	B	C	D	E	F
1-1/2" x 1-1/4" x 1-1/4"	02759	20	.19	2-1/2	1-1/2	1-11/16			
1-1/2" x 1-1/4" x 1-1/2"	02762	20	.23	2-3/4	1-3/4	1-3/4			
1-1/2" x 1-1/2" x 1-1/4"	02757	20	.20	2-1/2	1-11/16	1-13/16			
2" x 1-1/2" x 1-1/2"	02761	25	.29	3-1/8	1-15/16	2-3/16			
2" x 1-1/2" x 2"	02760	25	.34	3-11/16	2-5/16	2-5/16			
2" x 2" x 1-1/2"	02758	50	.30	3-1/8	1-15/16	2-3/16			
3" x 3" x 1-1/2"	02764	20	.62	2-11/16	1-3/4	2-9/16			
3" x 3" x 2"	02763	10	.71	3-5/16	2-1/8	2-7/8			
4" x 4" x 2"	02765	10	1.03	3-3/16	2-1/16	3-5/16			
4" x 4" x 3"	02766	10	1.42	4-3/4	3	3-9/16			
6" x 6" x 4"	02768	6	3.06	5-7/8	6-5/8	4-1/2			



TUBE & PIPE

METAL FITTINGS & NIPPLES

PLASTIC FITTINGS

VALVES

FILTER-DRIERS & STRAINERS

TEE • SANITARY • STREET

ABS DWV

A403

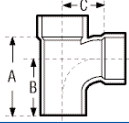

CONNECTION SP x H x H	CHARLOTTE STYLE 403		NIBCO STYLE 5811-2		Dimensions					
	Part Number	Ctn Qty	Approx Net Wt.	A	B	C	D	E	F	
1-1/2"	03112	20	.21	3-7/16	2-7/16	1-3/4				
2"	03113	25	.29	4-7/16	3-1/16	2-5/16				
3"	03114	30	.99	6-3/8	4-9/16	3-1/16				
4"	03120	10	1.76	7-7/8	5-5/8	3-7/8				

TEE • SANITARY • STREET • REDUCING

ABS DWV

A404

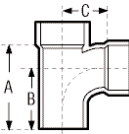

CONNECTION SP x H x H	CHARLOTTE STYLE 404		NIBCO STYLE 5811-2		Dimensions					
	Part Number	Ctn Qty	Approx Net Wt.	A	B	C	D	E	F	
2" x 1-1/2" x 1-1/2"	03115	25	.28	3-7/8	2-11/16	2-3/16				
2" x 1-1/2" x 2"	03116	25	.34	4-7/16	3-1/16	2-5/16				
2" x 2" x 1-1/2"	03117	25	.29	3-7/8	2-11/16	2-3/16				
3" x 3" x 1-1/2"	03118	10	.58	4-3/16	3-1/4	2-9/16				
3" x 3" x 2"	03119	10	.67	4-13/16	3-5/8	2-7/8				

TEE • SANITARY • W/LEFT SIDE INLET

ABS DWV

A416

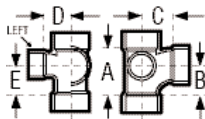

CONNECTION ALL HUB	CHARLOTTE STYLE 416		NIBCO STYLE 5871		Dimensions				
	Part Number	Ctn Qty	Approx Net Wt.	A	B	C	D	E	
3" x 3" x 2" x 2"	02780	10	.92	3-5/16	2-1/8	2-7/8	2-7/8	2-1/8	
3" x 3" x 3" x 1-1/2"	02781	10	1.08	4-7/8	3-1/16	3-1/16	2-9/16	3-11/16	
3" x 3" x 3" x 2"	02782	10	1.13	4-7/8	3-1/16	3-1/16	2-7/8	3-11/16	

TEE • SANITARY • W/RIGHT SIDE INLET

ABS DWV

A417

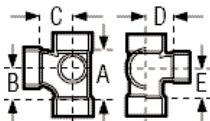

CONNECTION ALL HUB	CHARLOTTE STYLE 417		NIBCO STYLE 5872		Dimensions				
	Part Number	Ctn Qty	Approx Net Wt.	A	B	C	D	E	
3" x 3" x 3" x 1-1/2"	02795	10	1.12	4-7/8	3-1/16	3-1/16	2-9/16	3-11/16	
3" x 3" x 3" x 2"	02796	10	1.17	4-7/8	3-1/16	3-1/16	2-7/8	3-11/16	

TEE • SANITARY • W/RIGHT & LEFT INLET

ABS DWV

A418

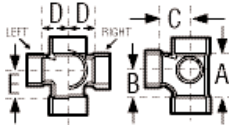

Size	Part Number	Ctn Qty	Approx Net Wt.	Dimensions				
				A	B	C	D	E
3" x 3" x 3" x 1-1/2" x 1-1/2"	02810	10	.39	4-7/8	3-1/16	3-1/16	2-9/16	3-11/16
3" x 3" x 3" x 2" x 2"	02811	5	1.30	4-7/8	3-1/16	3-1/16	2-7/8	3-11/16

TEE • DOUBLE • SANITARY

ABS DWV

A428

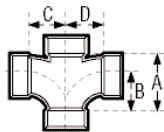

Size	Part Number	Ctn Qty	Approx Net Wt.	Dimensions			
				A	B	C	D
1-1/2"	02812	25	.28	2-3/4	1-3/4	1-3/4	1-3/4
2"	02813	20	.44	3-11/16	2-5/16	2-5/16	2-5/16
3"	02814	20	1.27	4-7/8	3-1/16	3-1/16	3-1/16
4"	02815	4	2.23	6-1/8	3-7/8	3-7/8	3-7/8

TEE • DOUBLE • SANITARY • REDUCING

ABS DWV

A429

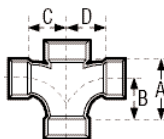

Size	Part Number	Ctn Qty	Approx Net Wt.	Dimensions				
				A	B	C	D	E
2" x 2" x 1-1/2" x 1-1/2"	02817	20	.36	3 1/8	1-15/16	2-3/16	2-3/16	
3" x 3" x 1-1/2" x 1-1/2"	02818	20	.64	2-11/16	1-3/4	2-9/16	2-9/16	
3" x 3" x 2" x 1-1/2"	02819	10	.75	3	2-1/16	2-1/2	2-7/16	
3" x 3" x 2" x 2"	02820	10	.74	3-5/16	2-1/8	2-7/8	2-7/8	
4" x 4" x 2" x 2"	02840	5	1.11	3-3/16	2-1/16	3-5/16	3-5/16	
4" x 4" x 3" x 3"	02821	5	1.61	4-3/4	3	3-9/16	3-9/16	

TEE • DOUBLE • SANITARY • STREET • REDUCING

ABS DWV

A431

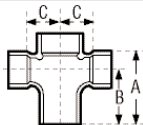

Size	Part Number	Ctn Qty	Approx Net Wt.	Dimensions		
				A	B	C
3" x 3" x 2" x 2"	03310	10	.80	4-13/16	3-5/8	2-7/8

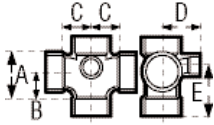

TEE • DOUBLE • SANITARY • W/SIDE INLET**ABS DWV****A438**

CONNECTION ALL HUB	CHARLOTTE STYLE		NIBCO STYLE		Dimensions				
	Part Number	Ctn Qty	Approx Net Wt.	A	B	C	D	E	
Size									
3" x 3" x 3" x 3" x 2"	02772	10	1.42	4-7/8	3-1/16	3-1/16	2-7/8	3-1/16	

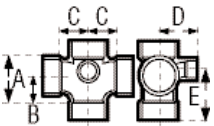
TEE • DOUBLE • SANITARY • W/RIGHT & LEFT SIDE INLET**ABS DWV****A439**

CONNECTION ALL HUB	CHARLOTTE STYLE		NIBCO STYLE		Dimensions				
	Part Number	Ctn Qty	Approx Net Wt.	A	B	C	D	E	
Size									
3" x 3" x 3" x 3" x 2" x 2"	02770	10	1.55	4-7/8	3-1/16	3-1/16	2-7/8	3-11/16	

(W/ RIGHT OR LEFT SIDE INLET)

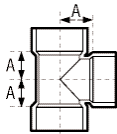
TEE • VENT**ABS DWV****A441**

CONNECTION ALL HUB	CHARLOTTE STYLE		NIBCO STYLE		Dimensions					
	Part Number	Ctn Qty	Approx Net Wt.	A	B	C	D	E	F	
Size										
1-1/2"	03403	25	.20	1-3/16						
2"	03404	25	.30	1-1/2						
3"	03405	10	.81	1-7/8						
4"	03406	5	1.40	2-1/2						

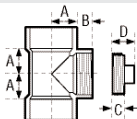
TEE • CLEANOUT • W/CLEANOUT PLUG**ABS DWV****A444X**

CONNECTION H x H x FPT	CHARLOTTE STYLE		NIBCO STYLE		Dimensions					
	Part Number	Ctn Qty	Approx Net Wt.	A	B	C	D	E	F	
Size										
1-1/2"	02997	10	.24	1-3/16	5/8	5/8	1-3/8			
2"	02998	10	.36	1-1/2	5/8	5/8	1-3/8			
3"	02999	10	.93	1-7/8	3/4	3/4	1-3/4			
4"	03000	5	1.64	2-1/2	7/8	7/8	1-7/8			

TEE • FLUSH CLEANOUT

ABS DWV

A445

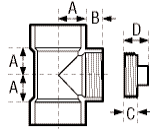

CONNECTION H x H x FPT	CHARLOTTE STYLE 445			NIBCO STYLE 5811-14-V					
	Part Number	Ctn Qty	Approx Net Wt.	Dimensions					
Size				A	B	C	D	E	F
1-1/2"	03413	20	.21	1-3/16	5/8				
2"	03414	20	.30	1-1/2	5/8				
3"	03415	10	.78	1-7/8	3/4				
4"	03416	10	1.38	2-1/2	7/8				

CLEANOUT • TWO WAY

ABS DWV

A448

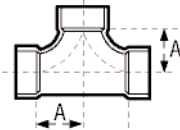

CONNECTION ALL HUB	CHARLOTTE STYLE 448			NIBCO STYLE 5811-C					
	Part Number	Ctn Qty	Approx Net Wt.	Dimensions					
Size				A	B	C	D	E	F
3"	02237	10	1.42	4-1/16					
4"	02238	5	2.48	4-15/16					

TEE • FIXTURE

ABS DWV

A450

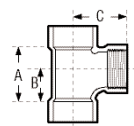

CONNECTION H x H x FPT	CHARLOTTE STYLE N/A			NIBCO STYLE 5811-14-FX					
	Part Number	Ctn Qty	Approx Net Wt.	Dimensions					
Size				A	B	C	D	E	
1-1/2"	03012	50	.21	2-3/4	1-9/16	2	1-1/4		
2" x 2" x 1-1/2"	03402	25	.24	2-3/4	1-7/16	2	1-1/4		

WYE • DOUBLE FIXTURE • STREET

ABS DWV

A499

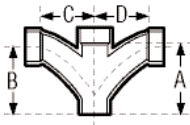

CONNECTION SP x H x H x H	CHARLOTTE STYLE N/A			NIBCO STYLE N/A					
	Part Number	Ctn Qty	Approx Net Wt.	Dimensions					
Size				A	B	C	D	E	
3"	02245	5	1.78	8-1/4	5-3/4	4-15/16	4-15/16		



WYE • DOUBLE FIXTURE

ABS DWV

A500

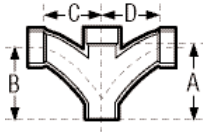

CONNECTION ALL HUB	CHARLOTTE STYLE		NIBCO STYLE		Dimensions				
	Part Number	Ctn Qty	Approx Net Wt.	A	B	C	D	E	
	500			5835-B					
Size									
2"	02246	25	.62	4-5/8	4-1/4	3-1/2	3-1/2		
3"	02249	10	.47	6-3/4	6-1/4	4-15/16	4-15/16		
REDUCING									
2" x 1-1/2" x 1-1/2" x 1-1/2"	02247	20	.42	3-1/2	3-1/8	2-7/8	2-7/8		
2" x 1-1/2" x 2" x 2"	02248	25	.58	4-5/8	4-1/4	3-1/2	3-1/2		
2" x 2" x 1-1/2" x 1-1/2"	02244	20	.50	3-1/4	3	3-3/4	2-3/4		
3" x 2" x 3" x 3"	02250	5	1.70	6-3/4	6-1/4	4-15/16	4-15/16		

COMBINATION WYE & 1/8 BEND-ONE PIECE

ABS DWV

A501

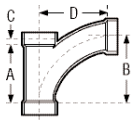

CONNECTION ALL HUB	CHARLOTTE STYLE		NIBCO STYLE		Dimensions					
	Part Number	Ctn Qty	Approx Net Wt.	A	B	C	D	E	F	
	501			5812-LR						
Size										
1-1/2"	02853	50	.32	3-1/2	3-15/16	7-1/16	3-15/16			
2"	02858	20	.54	4-7/16	5-1/8	1-1/16	5-1/8			
3"	02852	10	1.64	6-1/2	7-9/16	1-1/16	7-9/16			
4"	02860	10	3.08	8-1/2	10	1-1/2	10			

COMBINATION WYE & 1/8 BEND • REDUCING • ONE PIECE

ABS DWV

A502

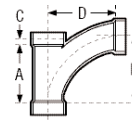

CONNECTION ALL HUB	CHARLOTTE STYLE		NIBCO STYLE		Dimensions				
	Part Number	Ctn Qty	Approx Net Wt.	A	B	C	D	E	
	502			5812-LR					
Size									
2" x 1-1/2" x 1-1/2"	02835	5	.34	3-1/2	3-15/16	7/16	4-3/16		
2" x 1-1/2" x 2"	02836	5	.52	4-7/16	5-1/8	1-1/16	5-1/8		
2" x 2" x 1-1/2"	02865	20	.37	3-1/2	3-15/16	7/16	4-3/16		
3" x 3" x 1-1/2"	02837	15	.78	3-1/2	3-15/16	7/16	4-3/4		
3" x 3" x 2"	02857	10	.95	4-7/16	5-1/8	1-1/16	5-11/16		
4" x 4" x 2"	02863	5	1.34	4-1/2	5-1/8	5/8	6-1/8		
4" x 4" x 3"	02864	5	2.08	6-1/2	7-9/16	1-1/16	8-1/16		

COMBINATION WYE & 1/8 BEND • TWO PIECE

ABS DWV

A503

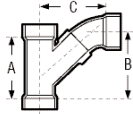

CONNECTION ALL HUB	CHARLOTTE STYLE			NIBCO STYLE			Dimensions			
	Part Number	Ctn Qty	Approx Net Wt.	A	B	C	D	E	F	
6"	02266	2	7.95	10	12-1/2	13-7/8				

COMBINATION WYE & 1/8 BEND • REDUCING • TWO PIECE

ABS DWV

A504

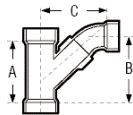

CONNECTION ALL HUB	CHARLOTTE STYLE			NIBCO STYLE			Dimensions			
	Part Number	Ctn Qty	Approx Net Wt.	A	B	C	D	E	F	
6" x 6" x 4"	02267	4	4.79	7	8-1/8	10				

DOUBLE COMBINATION WYE & 1/8 BEND

ABS DWV

(THREE PIECE)

A507

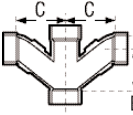

CONNECTION ALL HUB	CHARLOTTE STYLE			NIBCO STYLE			Dimensions			
	Part Size	Ctn Qty	Approx Net Wt.	A	B	C	D	E	F	
3"	02854	5	2.49	6-1/2	7-3/8	7-3/8				

WYE

ABS DWV

A600

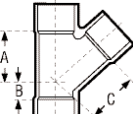

CONNECTION ALL HUB	CHARLOTTE STYLE			NIBCO STYLE			Dimensions			
	Part Number	Ctn Qty	Approx Net Wt.	A	B	C	D	E	F	
1-1/4"	02816	35	.23	2-9/16	1-1/16	2-9/16				
1-1/2"	02822	50	.29	2-7/8	1-1/8	2-7/8				
2"	02823	25	.44	3-5/8	1-3/8	3-5/8				
3"	02824	25	1.26	5	1-5/8	5				
4"	02825	5	2.29	6-3/8	1-7/8	6-3/8				
6"	03135	4	6.05	8-7/16	1-3/4	8-7/16				



WYE • REDUCING

ABS DWV

A601

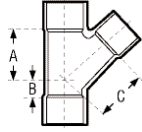
CONNECTION
ALL HUBCHARLOTTE STYLE
601NIBCO STYLE
5810

Size	Part Number	Ctn Qty	Approx Net Wt.	Dimensions					
				A	B	C	D	E	F
2" x 1-1/2" x 1-1/2"	02831	25	.33	2-13/16	3/4	2-15/16			
2" x 1-1/2" x 2"	02832	10	.47	3-1/2	1	3-3/8			
2" x 2" x 1-1/2"	02826	25	.38	3-5/16	1-1/16	3-7/16			
3" x 3" x 1-1/2"	02827	15	.78	3-3/4	1/2	4-5/16			
3" x 3" x 2"	02828	25	.87	4-1/8	7/8	4-5/8			
4" x 4" x 1-1/2"	02833	5	1.43	3-5/16	0	3-15/16			
4" x 4" x 2"	02829	10	1.37	4-11/16	3/8	5-9/16			
4" x 4" x 3"	02830	10	1.78	5-9/16	1-1/16	6			
6" x 6" x 4"	03137	5	3.44	6-11/16	3/16	7-7/16			

WYE • STREET

ABS DWV

A602

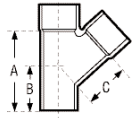
CONNECTION
SP x H x HCHARLOTTE STYLE
602NIBCO STYLE
5810-2

Size	Part Number	Ctn Qty	Approx Net Wt.	Dimensions					
				A	B	C	D	E	F
1-1/2"	03367	50	.28	2-7/8	1-13/16	2-7/8			
2"	03368	30	.43	3-5/8	2-1/8	3-5/8			
3"	03369	10	1.23	5	3-1/8	5			
4"	03370	5	2.24	6-3/8	3-5/8	6-3/8			

WYE • STREET • REDUCING

ABS DWV

A603

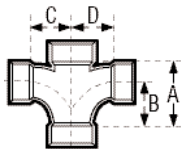
CONNECTION
SP x H x HCHARLOTTE STYLE
603NIBCO STYLE
5810-2

Size	Part Number	Ctn Qty	Approx Net Wt.	Dimensions					
				A	B	C	D	E	F
3" x 3" x 1-1/2"	03372	20	.76	3-3/4	2	4-5/16			
3" x 3" x 2"	03373	30	.84	4-1/8	2-3/8	4-5/8			
4" x 4" x 2"	03374	10	1.31	4-11/16	2-1/8	5-9/16			
4" x 4" x 3"	03375	10	1.72	5-9/16	2-13/16	6			

WYE • CLEANOUT

ABS DWV

A604

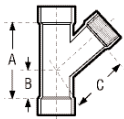

CONNECTION H x H x FPT	CHARLOTTE STYLE N/A			NIBCO STYLE N/A				
Size	Part Number	Ctn Qty	Approx Net Wt.	Dimensions				
				A	B	C	D	E
1-1/2"	03019	20	.285	4	1-1/8	2-7/8		

WYE • CLEANOUT • W/CLEANOUT PLUG

ABS DWV

A604X

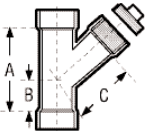

CONNECTION H x H x FPT	CHARLOTTE STYLE N/A			NIBCO STYLE N/A				
Size	Part Number	Ctn Qty	Approx Net Wt.	Dimensions				
				A	B	C	D	E
1-1/2"	02809	20	.35	4	1-1/8	2-7/8		

WYE • DOUBLE

ABS DWV

A611

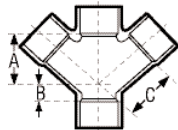

CONNECTION ALL HUB	CHARLOTTE STYLE 611			NIBCO STYLE 5834				
Size	Part Number	Ctn Qty	Approx Net Wt.	Dimensions				
				A	B	C	D	E
1-1/2"	02838	40	.37	2-7/8	1-1/8	2-7/8		
2"	02839	20	.55	3-5/8	1-3/8	3-5/8		
3"	02840	10	1.66	5	1-5/8	5		
4"	02841	5	2.88	6-3/8	1-7/8	6-3/8		

TUBE & PIPE

METAL FITTINGS & NIPPLES

PLASTIC FITTINGS

VALVES

FILTER-DRIERS & STRAINERS



WYE • DOUBLE • REDUCING

ABS DWV

A612

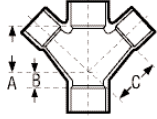

CONNECTION ALL HUB	CHARLOTTE STYLE		NIBCO STYLE		Dimensions				
	Part Number	Ctn Qty	Approx Net Wt.	A	B	C	D	E	
2" x 2" x 1-1/2" x 1-1/2"	02847	10	.45	3-5/16	1-1/16	3-7/16			
3" x 3" x 1-1/2" x 1-1/2"	02843	10	.81	3-3/4	1/2	4-5/16			
3" x 3" x 2" x 2"	02844	10	.95	4-1/8	7/8	4-5/8			
4" x 4" x 2" x 2"	02845	5	1.46	4-11/16	3/8	5-9/16			
4" x 4" x 3" x 3"	02846	5	2.10	5-9/16	1-1/16	6			
6" x 6" x 4" x 4"	03142	3	4.08	6-11/16	3/16	7-7/16			

RETURN BEND

ABS DWV

A700

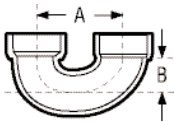

CONNECTION H x H	CHARLOTTE STYLE		NIBCO STYLE		Dimensions				
	Part Number	Ctn Qty	Approx Net Wt.	A	B	C	D	E	
1-1/2"	03466	20	.24	3-1/2	1-17/32				
2"	03467	35	.44	5-1/4	2-3/8				
3"	03468	10	1.30	6-3/4	3				
4"	03469	5	2.31	8-9/16	3-11/16				

RETURN BEND • W/CLEANOUT

ABS DWV

A701

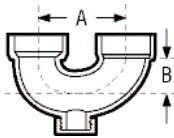

CONNECTION H x H	CHARLOTTE STYLE		NIBCO STYLE		Dimensions				
	Part Number	Ctn Qty	Approx Net Wt.	A	B	C	D	E	
1-1/2"	03471	20	.26	3-1/16	1-3/8				
2"	03472	10	.49	5-1/32	2-1/4				

ADAPTER • TAIL PIECE • W/ PLASTIC NUT

ABS DWV

A704P

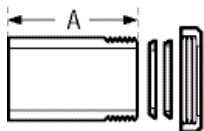

CONNECTION SP x SJ	CHARLOTTE STYLE		NIBCO STYLE		Dimensions				
	Part Number	Ctn Qty	Approx Net Wt.	A	B	C	D	E	
1-1/2" x 1-1/2"	02975	25	.10	2-5/8					
OR 1-1/2" x 1-1/4"	02975	25	.10	2-5/8					

(Furnished with both sizes S) washers)

P-TRAP • W/SOLVENT WELD JOINT

ABS DWV

A706X

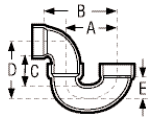

CONNECTION H x H	CHARLOTTE STYLE 706-X		NIBCO STYLE 5885		Dimensions				
	Part Number	Ctn Qty	Approx Net Wt.	A	B	C	D	E	
1-1/2"	02214	25	.38	3-1/2	4-23/32	2-11/32	3-5/8	1-17/32	
2"	02222	20	.64	5-1/4	6-7/8	2-7/8	5-1/8	2-3/8	
3"	02230	10	1.97	6-3/4	9-15/16	4-11/16	7-5/8	3	
4"	02231	4	3.47	8-9/16	12-7/16	5-1/4	7-9/16	3-11/16	

P-TRAP • W/SOLVENT WELD JOINT & CLEANOUT

ABS DWV

A707X

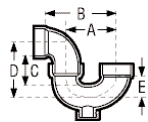

CONNECTION H x H	CHARLOTTE STYLE 707-X		NIBCO STYLE 5884		Dimensions					
	Part Number	Ctn Qty	Approx Net Wt.	A	B	C	D	E	F	
1-1/2"	02223	10	.40	3-1/16	4-9/32	2-1/8	3-5/8	1-3/8		
2"	02224	10	.65	5-1/32	6-3/8	2-1/2	5	2-1/4		

P-TRAP • W/UNION

ABS DWV

A708P

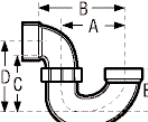

CONNECTION H x H	CHARLOTTE STYLE 708-P		NIBCO STYLE 5895		Dimensions					
	Part Number	Ctn Qty	Approx Net Wt.	A	B	C	D	E	F	
1-1/4"	02212	50	.38	3	4-1/8	2-1/16	3-3/8	1-3/8		
1-1/2"	02215	25	.42	3-1/2	4-23/32	2-11/32	3-5/8	1-17/32		
2"	02216	20	.69	5-1/4	6-7/8	2-7/8	5-1/8	2-3/8		

P-TRAP • LOW PROFILE W/SOLVENT WELD JOINT

ABS DWV

A710

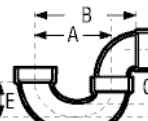

CONNECTION H x H	CHARLOTTE STYLE N/A		NIBCO STYLE N/A		Dimensions				
	Part Number	Ctn Qty	Approx Net Wt.	A	B	C	D	E	F
2"	02225	20	.64						

TUBE & PIPE

METAL FITTINGS & NIPPLES

PLASTIC FITTINGS

VALVES

FILTER-DRYERS & STRAINERS

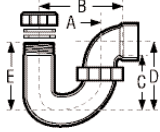

LA-TRAP • W/UNION & ONE-PIECE POLY NUT**ABS DWV****A711M**

CONNECTION SJ x H	CHARLOTTE STYLE		NIBCO STYLE		Dimensions				
	Part Number	Ctn Qty	Approx Net Wt.	A	B	C	D	E	
1-1/4" x 1-1/2"	02219	25	.51	3-13/16	5	2-1/2	4	4	
1-1/2"	02221	25	.51	3-13/16	5	2-1/2	4	4	

(W/Plastic Nut & Both 1-1/4" and 1-1/2" Washer)

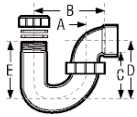
LA P-TRAP • W/UNION & 1-1/2 & 1-1/4 SJ WASHER - PLASTIC NUT**ABS DWV**(W/Plastic Nut & Both 1-1/4" & 1-1/2" Washer) **A711P**

CONNECTION SJ x H	CHARLOTTE STYLE		NIBCO STYLE		Dimensions				
	Part Number	Ctn Qty	Approx Net Wt.	A	B	C	D	E	
1-1/4" x 1-1/2"	02220	25	.51	3-13/16	5	2-1/2	4	4	
1-1/2" x 1-1/2"									

(* Top of Nut)

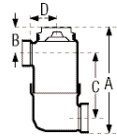
DRUM TRAP • W/CLEANOUT**ABS DWV****A720X**

CONNECTION H x H	CHARLOTTE STYLE		NIBCO STYLE		Dimensions					
	Part Number	Ctn Qty	Approx Net Wt.	A	B	C	D	E	F	
3" x 6" x 1-1/2"	03100	10	1.20	7-13/16	3	4-1/2	1-1/2			

(W/Plug)

CLOSET FLANGE**ABS DWV**

(One Piece W/ Slots)

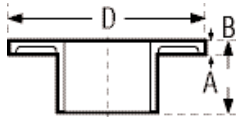
A800

CONNECTION H	CHARLOTTE STYLE		NIBCO STYLE		Dimensions					
	Part Number	Ctn Qty	Approx Net Wt.	A	B	C	D	E	F	
4"	02902	25	.50	7/16	-	2	7			

CLOSET FLANGE • W/STOP

ABS DWV

A800S

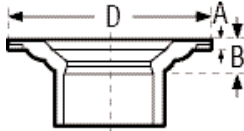
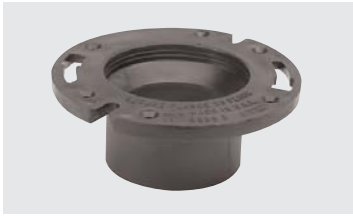

CONNECTION H	CHARLOTTE STYLE 800-S	NIBCO STYLE 5851	Dimensions						
Size	Part Number	Ctn Qty	Approx Net Wt.	A	B	C	D	E	F
4" x 3"	02903	25	.59	7/16	1-1/4	—	7		

CLOSET FLANGE • KNOCKOUT

ABS DWV

(One Piece W/Slots & Knockout Test Cap) **A800KO**

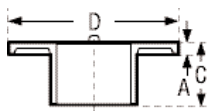

CONNECTION H	CHARLOTTE STYLE 800-KO	NIBCO STYLE 5855	Dimensions						
Size	Part Number	Ctn Qty	Approx Net Wt.	A	B	C	D	E	F
4"	02253	25	.54	7/16	—	2	7		
4" x 3"	02254	25	.58	7/16	1-1/4	—	7		

CLOSET FLANGE • SPIGOT • REDUCING

ABS DWV

(One Piece W/Slots)

A801

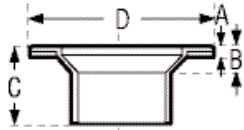
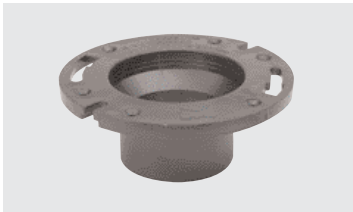

CONNECTION SP	CHARLOTTE STYLE 801	NIBCO STYLE 5851-2	Dimensions						
Size	Part Number	Ctn Qty	Approx Net Wt.	A	B	C	D	E	F
4" x 3"	02919	25	.53	7/16	1-1/4	2-3/4	7		

CLOSET FLANGE • W/GUSSET

ABS DWV

(One Piece W/Slots)

A802

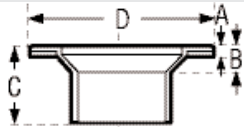
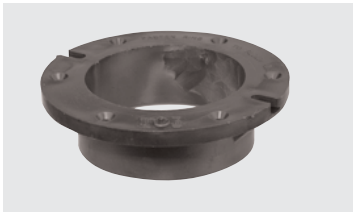

CONNECTION H	CHARLOTTE STYLE N/A	NIBCO STYLE N/A	Dimensions						
Size	Part Number	Ctn Qty	Approx Net Wt.	A	B	C	D	E	F
4"	02262	25	.51	7/16	—	2	7		

TUBE & PIPE

METAL FITTINGS & NIPPLES

PLASTIC FITTINGS

VALVES

FILTER-DRYERS & STRAINERS



CLOSET FLANGE • FEMALE**ABS DWV**

(W/O Slots)

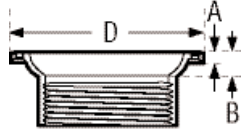
A807

CONNECTION	CHARLOTTE STYLE			NIBCO STYLE					
FPT	N/A			5851-3					
Size	Part Number	Ctn Qty	Approx Net Wt.	Dimensions					
				A	B	C	D	E	F
4" x 3"	02270	25	.47	7/16	1-1/4	—	7		

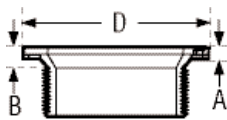
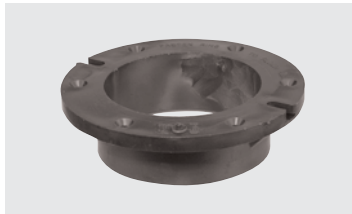
CLOSET FLANGE • MALE**ABS DWV****A808**

CONNECTION	CHARLOTTE STYLE			NIBCO STYLE					
MPT	N/A			5851-4					
Size	Part Number	Ctn Qty	Approx Net Wt.	Dimensions					
				A	B	C	D	E	F
4" x 3"	02260	25	.43	7/16	1-1/4	—	7		

CLOSET FLANGE • ADJUSTABLE W/PLASTIC RING**ABS DWV**

(W/Slots & Plastic Ring)

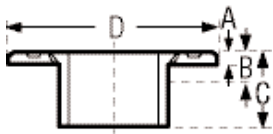
A810

CONNECTION	CHARLOTTE STYLE			NIBCO STYLE					
H	811-P			N/A					
Size	Part Number	Ctn Qty	Approx Net Wt.	Dimensions					
				A	B	C	D	E	F
4"	02256	25	.48	1/2	—	2-1/4	7		

CLOSET FLANGE • W/PIPE STOP • ADJUSTABLE • W/PLASTIC RING**ABS DWV**

(W/Pipe stop, slots & plastic ring)

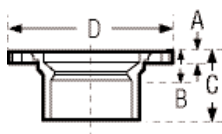
A810S

CONNECTION	CHARLOTTE STYLE			NIBCO STYLE					
H	811-P			N/A					
Size	Part Number	Ctn Qty	Approx Net Wt.	Dimensions					
				A	B	C	D	E	F
4" x 3"	02251	25	.50	1/2	1-1/4	2-3/4	7		

CLOSET FLANGE • ADJUSTABLE • W/METAL RING-EPOXY COATED

ABS DWV

A811

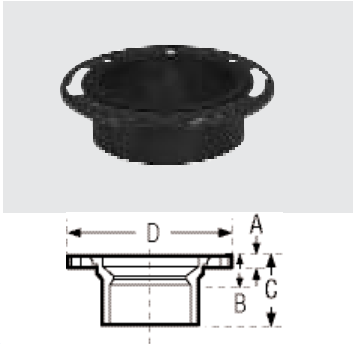

CONNECTION H	CHARLOTTE STYLE 811			NIBCO STYLE 5851-A		Dimensions				
	Part Number	Ctn Qty	Approx Net Wt.	A	B	C	D	E	F	
4"	02226	25	.60	5/16	—	2	7			
4" x 3"	02227	25	.71	5/16	1-1/4	2-3/4	7			

CLOSET FLANGE-SPIGOT • ADJUSTABLE • W/METAL RING-EPOXY COATED

ABS DWV

A812

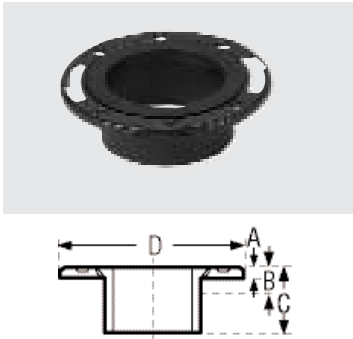

CONNECTION SP	CHARLOTTE STYLE 812			NIBCO STYLE 5851-2-A		Dimensions				
	Part Number	Ctn Qty	Approx Net Wt.	A	B	C	D	E	F	
4"	02229	25	.85	5/16	—	2-1/4	7			
4" x 3"	02228	25	.67	5/16	1-1/4	2-3/4	7			

CLOSET FLANGE • SPIGOT • ADJUSTABLE • W/PLASTIC RING

ABS DWV

A812P

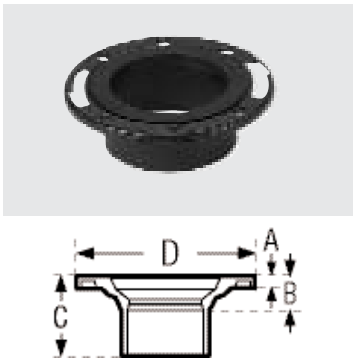

CONNECTION SP	CHARLOTTE STYLE 812-P			NIBCO STYLE N/A		Dimensions				
	Part Number	Ctn Qty	Approx Net Wt.	A	B	C	D	E	F	
4" x 3"	02252	25	.46	1/2	1-1/4	2-3/4	7			
4"	02264	25	.56	1/2	—	2-1/4	7			

FLUSH CLOSET FLANGE

ABS DWV

(Fits Over 3" or inside 4" Sch 40 DWV Pipe) **A815**

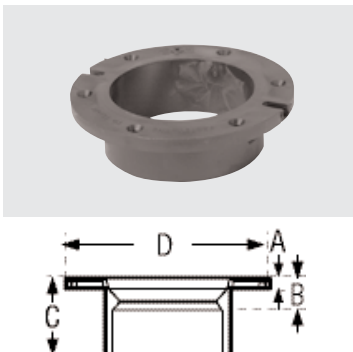

CONNECTION SP x H	CHARLOTTE STYLE 815			NIBCO STYLE 5853		Dimensions				
	Part Number	Ctn Qty	Approx Net Wt.	A	B	C	D	E	F	
4"	02255	25	.48	7/16	1-1/4	2-3/4	7			
OR 4" x 3"										



OFFSET CLOSET FLANGE • ADJUSTABLE W/METAL RING • EPOXY COATED

ABS DWV

A820

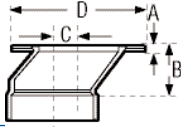

CONNECTION H	CHARLOTTE STYLE 820			NIBCO STYLE 5848-A						
	Part Number	Ctn Qty	Approx Net Wt.	Dimensions						
Size	A	B	C	D	E	F				
4" x 3"	02920	25	.89	5/16	2-3/4	1-1/2	7			

SWIVEL TRAY PLUG ADAPTER • W/WASHER

ABS DWV

(W/Rubber Washer)

A900

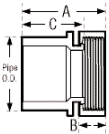

CONNECTION SP x NPSM Threaded	CHARLOTTE STYLE 900			NIBCO STYLE 5803-2-SW					
	Part Number	Ctn Qty	Approx Net Wt.	Dimensions					
Size	A	B	C	D	E	F			
1-1/2"	03418	50	.071	21/32	11/16	19/32			

SWIVEL TRAY PLUG ADAPTER EXTENDED SPIGOT • W/WASHER

ABS DWV

(W/Rubber Washer)

A900X

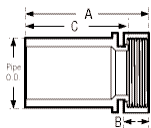

CONNECTION SP x NPSM Threaded	CHARLOTTE STYLE N/A			NIBCO STYLE N/A					
	Part Number	Ctn Qty	Approx Net Wt.	Dimensions					
Size	A	B	C	D	E	F			
1-1/2"	03013	50	.10	2-13/32	3/4	1			
1-1/4" x 1-1/2"	03420	50	.09	2-13/32	11/16	1-15/16			

SWIVEL TRAY PLUG ADAPTER • W/WASHER

ABS DWV

(W/Rubber Washer)

A910

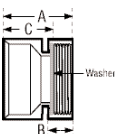

CONNECTION H x NPSM Threaded	CHARLOTTE STYLE 910			NIBCO STYLE 5803-SW						
	Part Number	Ctn Qty	Approx Net Wt.	Dimensions						
Size	A	B	C	D	E	F				
1-1/2"	03421	50	.09	1-23/32	11/16	19/32				
REDUCING										
1-1/4" x 1-1/2"	03417	50	.08	1-23/32	11/16	19/32				

PVC DWV Fittings



Mueller's PVC DWV fittings are made to the most exacting specifications to ensure the very best fit in the industry. Each fitting offers excellent rigidity, corrosion and chemical resistance while smooth walls prevent scaling and provide for free flow. Our precise manufacturing processes and stringent quality control ensure that our fittings perform flawlessly piece after piece. Fittings are packaged to common industry carton quantities and dimensions plus utilize an intuitive, recognizable style number system.

- Meets ASTM standard D2665 and D3311
- Made in the USA



TUBE & PIPE

METAL FITTINGS & NIPPLES

PLASTIC FITTINGS

VALVES

FILTER-DRIERS & STRAINERS

COUPLING

PVC DWV

PI00

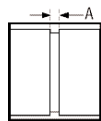

CONNECTION H x H	CHARLOTTE STYLE 100		NIBCO STYLE 4801		LASCO STYLE D100				
	Part Number	Ctn Qty	Approx Net Wt.	Dimensions					
Size				A	B	C	D	E	F
1-1/4"	05932	100	.07	1/8					
1-1/2"	05933	100	.09	1/8					
2"	05934	100	.14	1/8					
3"	05935	60	.45	3/16					
4"	05936	25	.80	1/4					
6"	06143	15	2.14	1/4					
8"	06145	4	6.41	1/4					

ADAPTER • FEMALE

PVC DWV

PI01

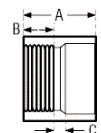

CONNECTION FPT x H	CHARLOTTE STYLE 101		NIBCO STYLE 4803		LASCO STYLE D101				
	Part Number	Ctn Qty	Approx Net Wt.	Dimensions					
Size				A	B	C	D	E	F
1-1/4"	05868	50	.10	1-5/8	15/16	1/4			
1-1/2"	05866	100	.10	1-5/8	15/16	1/4			
2"	05867	100	.15	1-7/8	1	1/4			
3"	05869	30	.49	3-1/32	1-27/32	15/16			
4"	06396	10	.78	3-3/32	1-15/16	11/32			
6"	06147	10	1.64	4-3/4	1-3/4	1/4			



PIPE INCREASER/REDUCER

PVC DWV

PI02

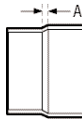
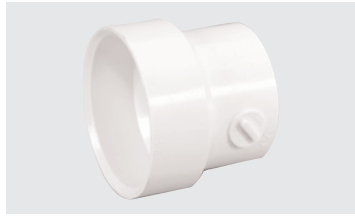

CONNECTION H x H	CHARLOTTE STYLE I02	NIBCO STYLE N/A	LASCO STYLE D102	Dimensions					
Size	Part Number	Ctn Qty	Approx Net Wt.	A	B	C	D	E	F
2" x 1-1/2"	05948	25	.15	17/32					
3" x 1-1/2"	05949	25	.41	1-7/16					
3" x 2"	05950	20	.15	17/32					
4" x 2"	05951	10	.70	1-3/8					
4" x 3"	05952	20	.76	5/8					
6" x 4"	05981	5	1.92	1-1/8					

ADAPTER • TRAP • MALE W/ONE-PIECE POLY NUT

PVC DWV

PI03P

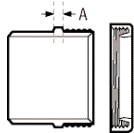

CONNECTION SP x SJ	CHARLOTTE STYLE I03P	NIBCO STYLE N/A	LASCO STYLE N/A	Dimensions					
Ctn Size	Part Number	Approx Qty	Approx Net Wt.	A	B	C	D	E	F
1-1/4"	06309	50	.12	3/16					
1-1/2"	06393	50	.11	3/16					
1-1/2" x 1-1/4"	06379	75	.11	3/16					

ADAPTER • TRAP • MALE W/PLASTIC NUT & BOTH 1-1/2 & 1-1/4 WASHERS

PVC DWV

PI03R

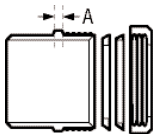
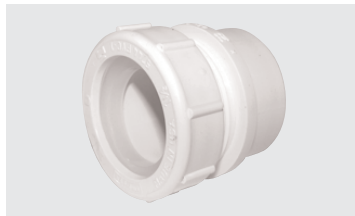

CONNECTION SP x SJ	CHARLOTTE STYLE I03R	NIBCO STYLE N/A	LASCO STYLE N/A	Dimensions					
Size	Part Number	Ctn Qty	Approx Net Wt.	A	B	C	D	E	F
1-1/2" x 1-1/4" OR 1-1/2" x 1-1/2"	06389	50	.14	3/16					

ADAPTER • TRAP • MALE W/PLASTIC NUT & WASHER

PVC DWV

PI03W

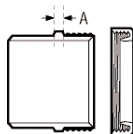

CONNECTION SP x SJ	CHARLOTTE STYLE N/A	NIBCO STYLE 4801-2-7	LASCO STYLE D113	Dimensions					
Size	Part Number	Ctn Qty	Approx Net Wt.	A	B	C	D	E	F
1-1/4"	06308	50	.11	3/16					
1-1/2"	06410	50	.11	3/16					
1-1/2" x 1-1/4"	06409	50	.11	3/16					
2"	06930	25	.17	3/16					

ADAPTER • TRAP • MALE CHROME NUT & WASHER

PVC DWV

PI03X

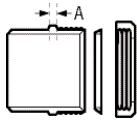

CONNECTION SP x SJ	CHARLOTTE STYLE 103X	NIBCO STYLE 4801-2-7-C	LASCO STYLE D115	Dimensions					
Size	Part Number	Ctn Qty	Approx Net Wt.	A	B	C	D	E	F
1-1/2"	06392	50	.15	3/16					
1-1/2" x 1-1/4"	06378	100	.15	3/16					

ADAPTER • TRAP • FEMALE ONE PIECE POLY NUT

PVC DWV

PI04P

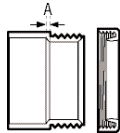

CONNECTION H x SJ	CHARLOTTE STYLE 104P	NIBCO STYLE N/A	LASCO STYLE N/A	Dimensions					
Size	Part Number	Ctn Qty	Approx Net Wt.	A	B	C	D	E	F
1-1/4"	06381	50	.11	3/16					
1-1/2"	06377	50	.12	3/16					
1-1/2" x 1-1/4"	06395	50	.09	3/16					

ADAPTER • TRAP • FEMALE PLASTIC NUT & WASHER

PVC DWV

PI04W

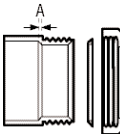

CONNECTION H x SJ	CHARLOTTE STYLE 104W	NIBCO STYLE 4801-7	LASCO STYLE D104	Dimensions					
Size	Part Number	Ctn Qty	Approx Net Wt.	A	B	C	D	E	F
1-1/4"	06380	50	.13	3/16					
1-1/2"	06383	50	.13	3/16					
1-1/2" x 1-1/4"	06384	50	.13	3/16					
2"	06382	25	.18	3/16					

ADAPTER • TRAP • FEMALE W/CHROME NUT & WASHER

PVC DWV

PI04X

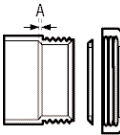

CONNECTION H x SJ	CHARLOTTE STYLE 104X	NIBCO STYLE 4801-7-C	LASCO STYLE D116	Dimensions					
Size	Part Number	Ctn Qty	Approx Net Wt.	A	B	C	D	E	F
1-1/2"	06376	50	.17	3/16					
2"	06397	25	.24	3/16					
1-1/2" x 1-1/4"	06394	50	.15	3/16					

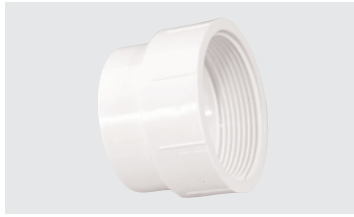

ADAPTER • CLEANOUT**PVC DWV****PI05**

CONNECTION SP x FPT	CHARLOTTE STYLE 105		NIBCO STYLE 4803-2		LASCO STYLE D105				
Size	Part Number	Ctn Qty	Approx Net Wt.	Dimensions					
				A	B	C	D	E	F
1-1/4"	05918	50	.14	1-19/32	27/32	5/32			
1-1/2"	05922	50	.09	1-5/8	7/8	5/32			
2"	05923	50	.12	1-17/32	29/32	5/32			
3"	05924	25	.45	2-29/32	1-13/64	3/16			
4"	05925	10	.70	3-13/32	1-5/16	1/4			
6"	06148	10	1.53	4-7/8	1-7/8	3/8			

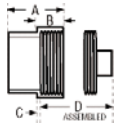
ADAPTER • CLEANOUT • W/CLEANOUT PLUG**PVC DWV****PI05X**

CONNECTION SP x FPT	CHARLOTTE STYLE 105X		NIBCO STYLE 4816		LASCO STYLE D112				
Size	Part Number	Ctn Qty	Approx Net Wt.	Dimensions					
				A	B	C	D	E	F
1-1/4"	06007	50	.15	1-19/32	27/32	5/32	13/16		
1-1/2"	06001	50	.15	1-5/8	7/8	5/32	1-15/32		
2"	06002	50	.21	1-17/32	29/32	5/32	1-1/2		
3"	06003	25	.56	2-29/32	1-13/64	3/16	2-1/64		
4"	06004	10	.92	3-13/32	1-5/16	1/4	2-1/16		
6"	06005	10	2.53	4-7/8	1-7/8	3/8	2-1/2		

PLUG • CLEANOUT**PVC DWV****PI06**

CONNECTION MPT	CHARLOTTE STYLE 106		NIBCO STYLE 4818		LASCO STYLE D106				
Size	Part Number	Ctn Qty	Approx Net Wt.	Dimensions					
				A	B	C	D	E	F
1-1/4"	05937	100	.07	1/2	1				
1-1/2"	05938	50	.06	5/8	1-3/8				
2"	05939	50	.09	3/4	1-3/8				
3"	05941	25	.19	3/4	1-3/4				
4"	05942	30	.34	7/8	1-7/8				
6"	06146	10	.80	1	2				

PLUG • SLIP**PVC DWV****PI06P**

CONNECTION SP	CHARLOTTE STYLE N/A		NIBCO STYLE N/A		LASCO STYLE N/A				
Size	Part Number	Ctn Qty	Approx Net Wt.	Dimensions					
				A	B	C	D	E	F
1-1/2"	06055	25	.05	1-1/16					
2"	06056	50	.08	1-1/8					

BUSHING • FLUSH

PVC DWV

PI07

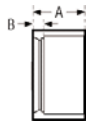

Style #3

CONNECTION SP x H	CHARLOTTE STYLE 107	NIBCO STYLE 4801-2-F	LASCO STYLE D107	Dimensions					
Size	Part Number	Ctn Qty	Approx Net Wt.	A	B	C	D	E	F
1-1/2" x 1-1/4"	05904	100	.05	1	3/16				
2" x 1-1/4"	05905	50	.14	1-1/16	5/16				
2" x 1-1/2"	05906	50	.11	1-1/16	5/16				
3" x 1-1/2"	05907	30	.35	1-1/2	3/4				
3" x 2"	05908	30	.34	1-1/2	3/4				
4" x 2"	05910	30	.54	2	1/4				
4" x 3"	05909	30	.53	1-3/4	1/4				

BUSHING • FLANGE • W/TUBE STOP

PVC DWV

PI07S

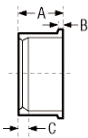

Style #1

CONNECTION SP x H	CHARLOTTE STYLE N/A	NIBCO STYLE N/A	LASCO STYLE N/A	Dimensions					
Size	Part Number	Ctn Qty	Approx Net Wt.	A	B	C	D	E	F
6" x 4"	06144	10	1.92	3-1/2	1/2	1-3/4			
EXTENDED									
8" x 6"	06149	4	4.00	4-5/8	5/8	1-5/8			

BUSHING • FLUSH • (CLEANOUT ADAPTER)

PVC DWV

PI08

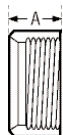
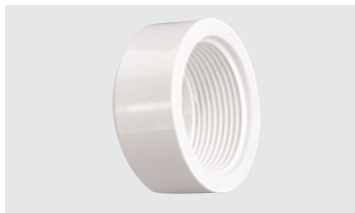

Style #3

CONNECTION SP x FPT	CHARLOTTE STYLE 108	NIBCO STYLE 4803-2-F	LASCO STYLE D108	Dimensions					
Size	Part Number	Ctn Qty	Approx Net Wt.	A	B	C	D	E	F
2" x 1-1/2"	05913	50	.11	1-1/16					

TUBE & PIPE

METAL FITTINGS & NIPPLES

PLASTIC FITTINGS

VALVES

FILTER-DRIERS & STRAINERS



ADAPTER • MALE

PVC DWV

PI09

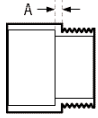

CONNECTION H x MPT	CHARLOTTE STYLE 109	NIBCO STYLE 4804	LASCO STYLE D109	Dimensions					
Size	Part Number	Ctn Qty	Approx Net Wt.	A	B	C	D	E	F
1-1/4"	05931	50	.08	3/16					
1-1/2"	05927	50	.09	3/16					
2"	05928	50	.14	3/16					
3"	05929	25	.46	3/8					
4"	05930	25	.63	3/8					
REDUCING									
1-1/2" x 1-1/4"	05926	25	.10	3/16					

PLUG • FLUSH CLEANOUT

PVC DWV

PI10

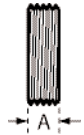

(W/SLOTS)

CONNECTION MPT	CHARLOTTE STYLE 110	NIBCO STYLE N/A	LASCO STYLE D110	Dimensions					
Size	Part Number	Ctn Qty	Approx Net Wt.	A	B	C	D	E	F
4"	06015	25	.38	3/4					

ADAPTER • MALE

PVC DWV

PI11

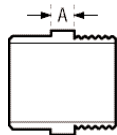
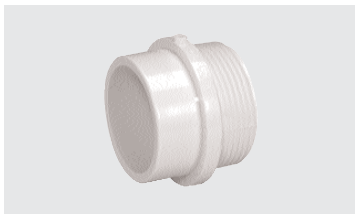

CONNECTION SP x MPT	CHARLOTTE STYLE 111	NIBCO STYLE 4804-2	LASCO STYLE N/A	Dimensions					
Size	Part Number	Ctn Qty	Approx Net Wt.	A	B	C	D	E	F
1-1/4"	06010	50	.08	5/32					
1-1/2"	06386	50	.09	5/32					
2"	06385	25	.17	5/32					
3"	06366	25	.37	3/8					
REDUCING									
1-1/2" x 1-1/4"	06387	100	.08	5/16					

ADAPTER • TRAY PLUG

PVC DWV

PI13

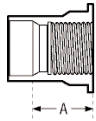
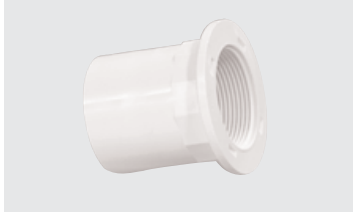

CONNECTION H x NPSM THREAD	CHARLOTTE STYLE N/A			NIBCO STYLE N/A		LASCO STYLE N/A			
	Part Number	Ctn Qty	Approx Net Wt.	Dimensions					
Size				A	B	C	D	E	F
1-1/2"	06014	50	.34	1-7/8					

ADAPTER • TRAY PLUG • SPIGOT

PVC DWV

PI13S

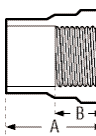
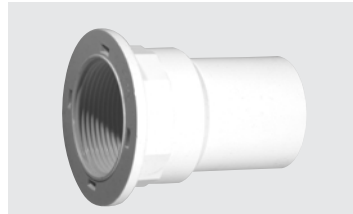

CONNECTION SP X NPSM THREAD	CHARLOTTE STYLE N/A			NIBCO STYLE N/A		LASCO STYLE N/A			
	Part Number	Ctn Qty	Approx Net Wt.	Dimensions					
Size				A	B	C	D	E	F
1-1/2"	06419	50	.18	3-3/8	1-9/16				

CAP • THREADED

PVC DWV

PI14



CONNECTION FPT	CHARLOTTE STYLE N/A			NIBCO STYLE N/A		LASCO STYLE N/A			
	Part Number	Ctn Qty	Approx Net Wt.	Dimensions					
Size				A	B	C	D	E	F
1-1/2"	05993	100	.08	7/8					
2"	05994	50	.12	7/8					

TUBE & PIPE

METAL FITTINGS
& NIPPLES

PLASTIC
FITTINGS

VALVES

FILTER-DRIERS
& STRAINERS



CAP • SOCKET

PVC DWV

PI16

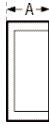

Size	Part Number	Ctn Qty	Approx Net Wt.	Dimensions					
				A	B	C	D	E	F
1-1/2"	05977	50	.09	1-1/16					
2"	05978	25	.13	1-3/16					
3"	05979	25	.38	2-1/4					
4"	05980	5	.69	2-5/16					
6"	06057	5	2.25	3-3/4					
8"	06058	3	3.90	4-7/8					

COUPLING • ADAPTER

PVC DWV

PI17

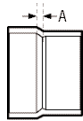

Size	Part Number	Ctn Qty	Approx Net Wt.	Dimensions					
				A	B	C	D	E	F
3"	05970	10	.63	1/8					
4"	05963	10	.60	1/4					
4" x 3"	05962	20	.55	1/4					

(ADAPTS SEWER & DRAIN PIPE TO DWV PIPE)

COUPLING • ADAPTER

PVC DWV

PI17X

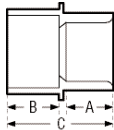

Size	Part Number	Ctn Qty	Approx Net Wt.	Dimensions					
				A	B	C	D	E	F
4" x 3"	05992	10	.48	3/16	1-3/4	3-1/2			

(ADAPTS 4" S/D HUB TO 3" DWV PIPE)

BUSHING • ADAPTER (DWV SPIGOT X S/D HUB)

PVC DWV

PI18



Size	Part Number	Ctn Qty	Approx Net Wt.	Dimensions					
				A	B	C	D	E	F
3"	05990	25	.12	1-1/2	1-3/4				
4"	05991	10	.20	1-3/4	2				

(ADAPTS DWV HUB TO S/D PIPE)

ADAPTER • NO HUB

PVC DWV

PI19

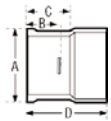

(ADAPTS CI NO HUB TO DWV PIPE)

CONNECTION CI NO H X DWV H	CHARLOTTE STYLE 119		NIBCO STYLE N/A		Dimensions					
	Part Number	Ctn Qty	Approx Net Wt.	A	B	C	D	E	F	
2"	05954	25	.16	2-3/8	1-1/8	1-5/8	2-1/2			
3"	05955	20	.40	3-3/8	1-1/8	1-7/8	3-3/8			
4"	05956	15	.63	4-7/16	1-1/8	1-15/16	3-11/16			
REDUCING										
4" x 3"	05953	10	.44	4-7/16	1-1/8	1-15/16	3-7/16			

ADAPTER • SCHEDULE 40 TO SCHEDULE 30

PVC DWV

PI20

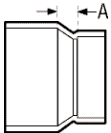

(ADAPTS 3" SCH. 40 TO 3" SCH. 30)

CONNECTION H x H	CHARLOTTE STYLE N/A		NIBCO STYLE N/A		Dimensions					
	Part Number	Ctn Qty	Approx Net Wt.	A	B	C	D	E	F	
3"	05996	20	.15	1/8						

ADAPTER • SPIGOT • CAST IRON

PVC DWV

PI22

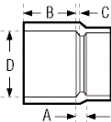

(ADAPTS CI SPIGOT TO DWV PIPE)

CONNECTION CI H x DWV H	CHARLOTTE STYLE 122		NIBCO STYLE 4800		Dimensions					
	Part Number	Ctn Qty	Approx Net Wt.	A	B	C	D	E	F	
2"	05944	50	.31	5/16	2-3/8	1/8	2-5/16			
4"	05946	10	1.13	5/16	2-7/8	1/8	4-5/16			

ADAPTER • HUB • CAST IRON

PVC DWV

PI23

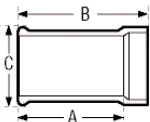
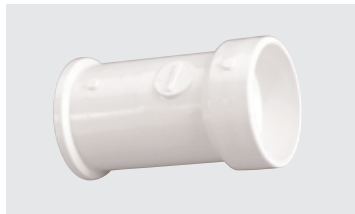

(ADAPTS CI HUB TO DWV PIPE)

CONNECTION CI SP x DWV H	CHARLOTTE STYLE 123		NIBCO STYLE 4805		Dimensions					
	Part Number	Ctn Qty	Approx Net Wt.	A	B	C	D	E	F	
2"	05957	20	.31	3-1/2	4-3/4	2-3/4				
3"	05958	20	.74	4-1/4	5-7/8	3-3/4				
4"	05959	20	1.17	4-7/8	6-5/8	4-3/4				

TUBE & PIPE

METAL FITTINGS & NIPPLES

PLASTIC FITTINGS

VALVES

FILTER-DRIERS & STRAINERS



ADAPTER • HUB • CAST IRON • INCREASER

PVC DWV

PI23R

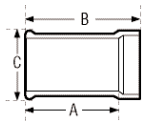

CONNECTION CI SP x DWV H	CHARLOTTE STYLE 123-R		NIBCO STYLE 4805		LASCO STYLE D123					
	Part Number	Ctn Qty	Approx Net Wt.	A	B	Dimensions C D E F				
2" x 1-1/2"	05961	10	.28	3-9/16	4-7/8	3-5/8				
3" x 1-1/2"	05964	10	.45	4	5-1/16	3-7/8				
3" x 2"	06398	20	.52	3-3/8	4-1/8	2-5/8				
4" x 3"	05960	10	1.04	4	5-3/4	4-3/4				

(ADAPTS CI HUB TO DWV PIPE)

COUPLING • REPAIR

PVC DWV

PI30



CONNECTION H x H	CHARLOTTE STYLE 130		NIBCO STYLE 4801-RP		LASCO STYLE D130					
	Part Size	Ctn Number	Approx Qty	Net Wt.	A	B	C	D	E	F
1-1/2"	05965	20	.09	1-1/2						
2"	05966	25	.12	1-3/4						
3"	05967	10	.44	3						
4"	05968	5	.77	3-1/2						

NUT • SLIP JOINT • PLASTIC

PVC DWV

PI40

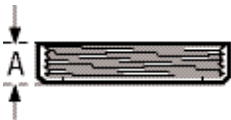

CONNECTION NPSM THREAD	CHARLOTTE STYLE N/A		NIBCO STYLE N/A		LASCO STYLE N/A					
	Part Number	Ctn Qty	Approx Net Wt.	A	B	Dimensions C D E F				
1-1/4"	05743	400	.04	11/16						
1-1/2"	05744	100	.04	11/16						
2"	05741	100		11/16						

NUT • I PIECE POLY

PVC DWV

PI42

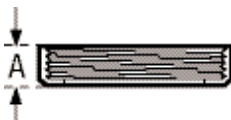

CONNECTION SJ x NPSM THREAD	CHARLOTTE STYLE N/A		NIBCO STYLE N/A		LASCO STYLE N/A					
	Part Number	Ctn Qty	Approx Net Wt.	A	B	Dimensions C D E F				
1-1/4"	01036	150	.023	5/8						
1-1/2"	01038	125	.025	5/8						

ELBOW • 1/4 BEND

PVC DWV

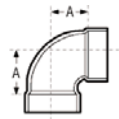

P300

CONNECTION H x H	CHARLOTTE STYLE			NIBCO STYLE	LASCO STYLE					
	300			4807	D300					
Size	Part Number	Ctn Qty	Approx Net Wt.	Dimensions						
				A	B	C	D	E	F	
1-1/4"	05875	50	.17	1-9/16						
1-1/2"	05876	100	.22	1-3/4						
2"	05877	50	.34	2-5/16						
3"	05878	25	1.04	3-1/16						
4"	05879	10	1.85	3-7/8						
6"	06130	5	4.90	5						
8"	06131	2	4.83	6-1/8						

ELBOW • 1/4 BEND • REDUCING

PVC DWV

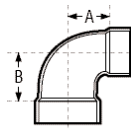

P300R

CONNECTION H x H	CHARLOTTE STYLE			NIBCO STYLE	LASCO STYLE					
	300-R			4807	D300					
Size	Part Number	Ctn Qty	Approx Net Wt.	Dimensions						
				A	B	C	D	E	F	
2" x 1-1/2"	06092	10	.31	2-5/16	2-7/16					

ELBOW • 1/4 BEND • W/SIDE INLET

PVC DWV

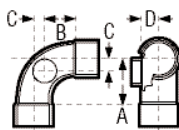

P300S

CONNECTION ALL HUB	CHARLOTTE STYLE			NIBCO STYLE	LASCO STYLE					
	300-S			4807-9	D301					
Size	Part Number	Ctn Qty	Approx Net Wt.	Dimensions						
				A	B	C	D	E	F	
3" x 3" x 1-1/2"	06069	10	1.05	3-1/16	2-1/16	1	1-7/8			
3" x 3" x 2"	06070	10	1.10	3-1/16	2-1/16	1	1-7/8			

ELBOW • 1/4 BEND • STREET

PVC DWV

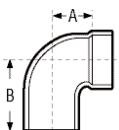

P302

CONNECTION SP x H	CHARLOTTE STYLE			NIBCO STYLE	LASCO STYLE					
	302			4807-2	D302					
Size	Part Number	Ctn Qty	Approx Net Wt.	Dimensions						
				A	B	C	D	E	F	
1-1/4"	05894	50	.17	1-9/16	2-1/4					
1-1/2"	05880	100	.20	1-3/4	2-7/16					
2"	05881	50	.34	2-5/16	3-1/16					
3"	05882	20	.95	3-1/16	4-9/16					
4"	05883	10	1.75	3-7/8	5-5/8					
6"	05889	5	4.65	5	8					



ELBOW • 1/4 BEND • W/LOW HEEL INLET

PVC DWV

P303

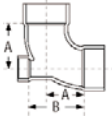

CONNECTION ALL HUB	CHARLOTTE STYLE 303	NIBCO STYLE 4861-LH	LASCO STYLE D303						
Size	Part Number	Ctn Qty	Approx Net Wt.	Dimensions					
				A	B	C	D	E	F
3" x 3" x 1-1/2"	06041	25	1.07	3-1/16	4-1/2				
3" x 3" x 2"	06042	25	1.13	3-1/16	4-7/16				
4" x 4" x 2"	06043	15	1.56	3-7/8	5-7/16				

ELBOW • LONG SWEEP • 1/4 BEND

PVC DWV

P304

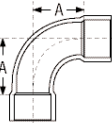

CONNECTION H x H	CHARLOTTE STYLE 304	NIBCO STYLE 4807-LT	LASCO STYLE D304						
Part Size	Ctn Number	Approx Qty	Approx Net Wt.	Dimensions					
				A	B	C	D	E	F
1-1/2"	05871	50	.28	2-3/4					
2"	05872	25	.45	3-1/4					
3"	05873	10	1.27	4-1/16					
4"	05874	5	2.23	4-15/16					

ELBOW • LONG SWEEP • 1/4 BEND W/HIGH HEEL INLET

PVC DWV

P305

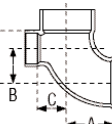

CONNECTION ALL HUB	CHARLOTTE STYLE 305	NIBCO STYLE 4861	LASCO STYLE N/A						
Size	Part Number	Ctn Qty	Approx Net Wt.	Dimensions					
				A	B	C	D	E	F
3" x 3" x 1-1/2"	06028	10	1.29	4-1/16	2-1/4	1-9/16	3-5/8		
3" x 3" x 2"	06027	25	1.29	4-1/16	2-1/4	1-9/16	4-1/16		

ELBOW • LONG SWEEP • 1/4 BEND W/LOW HEEL INLET

PVC DWV

P307

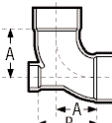

CONNECTION ALL HUB	CHARLOTTE STYLE 307	NIBCO STYLE N/A	LASCO STYLE D307						
Size	Part Number	Ctn Qty	Approx Net Wt.	Dimensions					
				A	B	C	D	E	F
3" x 3" x 1-1/2"	06025	10	1.30	4-1/16	4-3/4				
3 x 3" x 2"	06024	25	1.31	4-1/16	4-15/16				

ELBOW • 1/6 BEND • STREET

PVC DWV

P320

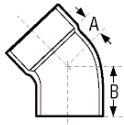

CONNECTION SP x H	CHARLOTTE STYLE 320	NIBCO STYLE 4860-2	LASCO STYLE N/A	Dimensions					
Size	Part Number	Ctn Qty	Approx Net Wt.	A	B	C	D	E	F
1-1/2"	06020	50	.17	1	1 1/16				
2"	06021	20	.27	1-7/16	2-1/16				
3"	06022	20	.80	1-11/16	3-3/16				
4"	06023	5	1.54	2-1/16	3-9/16				

ELBOW • 1/8 BEND

PVC DWV

P321

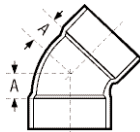

CONNECTION H x H	CHARLOTTE STYLE 321	NIBCO STYLE 4806	LASCO STYLE D321	Dimensions					
Size	Part Number	Ctn Qty	Approx Net Wt.	A	B	C	D	E	F
1-1/4"	05884	50	.14	1					
1-1/2"	05885	100	.18	1-1/8					
2"	05886	50	.30	1-1/2					
3"	05887	20	.82	1-3/4					
4"	05888	10	1.50	2-3/16					
6"	06132	3	4.11	3-3/8					
8"	06134	3	6.13	3-3/4					

ELBOW • 1/8 BEND • STREET

PVC DWV

P323

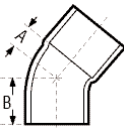

CONNECTION SP x H	CHARLOTTE STYLE 323	NIBCO STYLE 4806-2	LASCO STYLE D323	Dimensions					
Size	Part Number	Ctn Qty	Approx Net Wt.	A	B	C	D	E	F
1-1/4"	06016	50	.14	1	1-11/16				
1-1/2"	05890	100	.17	1-1/8	1-13/16				
2"	05891	50	.28	1-1/2	2-1/4				
3"	05892	20	.76	1-3/4	3-1/4				
4"	05893	10	1.37	2-3/16	3-15/16				
6"	06133	3	3.95	3-3/8	6-3/8				
8"	06136	3	8.40	3-5/8	8-1/8				

ELBOW • 1/16 BEND

PVC DWV

P324

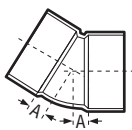

CONNECTION H x H	CHARLOTTE STYLE 324	NIBCO STYLE 4808	LASCO STYLE D324	Dimensions					
Size	Part Number	Ctn Qty	Approx Net Wt.	A	B	C	D	E	F
1-1/2"	05899	50	.14	1/2					
2"	05900	25	.22	1 1/16					
3"	05901	20	.66	1 3/16					
4"	05983	15	1.17	1 5/16					
6"	05988	3	3.01	1-7/16					



TUBE & PIPE

METAL FITTINGS & NIPPLES

PLASTIC FITTINGS

VALVES

FILTER-DRIERS & STRAINERS

ELBOW • 1/16 BEND • STREET

PVC DWV

P326

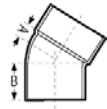

CONNECTION SP x H	CHARLOTTE STYLE 326	NIBCO STYLE 4808-2	LASCO STYLE D326	Dimensions					
Size	Part Number	Ctn Qty	Approx Net Wt.	A	B	C	D	E	F
1-1/2"	05984	50	.12	1/2	1-3/16				
2"	05985	25	.21	11/16	1-7/16				
3"	05986	20	.61	13/16	2-5/16				
4"	05987	10	1.03	1	2-3/4				

ELBOW • DOUBLE • 1/4 BEND

PVC DWV

P327

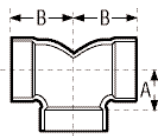

CONNECTION ALL HUB	CHARLOTTE STYLE 327	NIBCO STYLE 4837	LASCO STYLE D327	Dimensions					
Size	Part Number	Ctn Qty	Approx Net Wt.	A	B	C	D	E	F
1-1/2"	06045	20	.32	1-3/4	1-3/4				
2"	06046	25	.41	2-5/16	2-5/16				
3"	06047	10	1.52	3-1/16	3-1/16				
4"	06048	5	2.65	3-7/8	3-7/8				
REDUCING									
2" x 1-1/2" x 1-1/2"	06049	25	.32	1-15/16	1-3/4				

ELBOW • CLOSET BEND • REDUCING

PVC DWV

P329

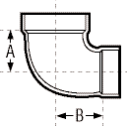

CONNECTION H x H	CHARLOTTE STYLE 329	NIBCO STYLE 4807-CL	LASCO STYLE D329	Dimensions					
Size	Part Number	Ctn Qty	Approx Net Wt.	A	B	C	D	E	F
4" x 3"	06093	10	1.35	3	3-3/8				

ELBOW • CLOSET BEND • REDUCING • STREET

PVC DWV

P330

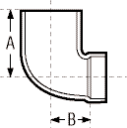

CONNECTION H x H	CHARLOTTE STYLE 330	NIBCO STYLE 4807-2-CL	LASCO STYLE D330	Dimensions					
Size	Part Number	Ctn Qty	Approx Net Wt.	A	B	C	D	E	F
4" x 3"	06107	10	1.49	6	3-3/8				

ELBOW • CLOSET BEND • REDUCING • STREET W/TEST CAP

PVC DWV

P330X

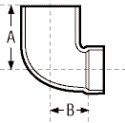

CONNECTION SP x H	CHARLOTTE STYLE 330X	NIBCO STYLE N/A	LASCO STYLE N/A	Dimensions					
Size	Part Number	Ctn Qty	Approx Net Wt.	A	B	C	D	E	F
4" x 3"	06108	10	1.60	6-1/16	3-3/8				

ELBOW • VENT ELL

PVC DWV

P331

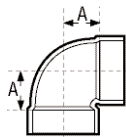

CONNECTION H x H	CHARLOTTE STYLE 331	NIBCO STYLE 4807-V	LASCO STYLE D331	Dimensions					
Size	Part Number	Ctn Qty	Approx Net Wt.	A	B	C	D	E	F
1-1/4"	06083	20	.16	1					
1-1/2"	06084	20	.20	1-3/16					
2"	06085	30	.29	1-1/2					
3"	06086	25	.84	1-7/8					

ELBOW • VENT ELL • STREET

PVC DWV

P333

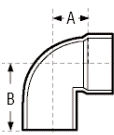

CONNECTION SP x H	CHARLOTTE STYLE 333	NIBCO STYLE 4807-2-V	LASCO STYLE D333	Dimensions					
Size	Part Number	Ctn Qty	Approx Net Wt.	A	B	C	D	E	F
1-1/4"	06091	20	.15	1	1-11/16				
1-1/2"	06088	25	.18	1-3/16	1-7/8				
2"	06089	20	.27	1-1/2	2-1/4				
3"	06090	10	.81	1-9/16	2-5/8				

TEE • SANITARY

PVC DWV

P400

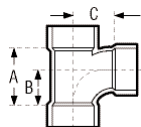

CONNECTION ALL HUB	CHARLOTTE STYLE 400	NIBCO STYLE 4811	LASCO STYLE D400	Dimensions					
Size	Part Number	Ctn Qty	Approx Net Wt.	A	B	C	D	E	F
1-1/4"	05751	50	.24	2-5/16	1-9/16	1-9/16			
1-1/2"	05752	100	.30	2-3/4	1-3/4	1-3/4			
2"	05753	35	.50	3-11/16	2-5/16	2-5/16			
3"	05754	30	1.39	4-7/8	3-1/16	3-1/16			
4"	05755	5	2.45	6-1/8	3-7/8	3-7/8			
6"	05756	5	6.10	8-1/2	5	5			
8"	05775	1	11.70	10-1/2	6	6			



TEE • SANITARY • REDUCING

PVC DWV

P401

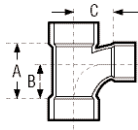

CONNECTION	CHARLOTTE STYLE	NIBCO STYLE	LASCO STYLE	Dimensions					
ALL HUB	401	4811	D401	A	B	C	D	E	F
Size	Part Number	Ctn Qty	Approx Net Wt.						
1-1/2" x 1-1/2" x 1-1/4"	05757	20	.32	2-1/2	1-11/16	1-13/16			
2" x 1-1/2" x 1-1/2"	05761	25	.39	3-1/8	1-15/16	2-3/16			
2" x 1-1/2" x 2"	05760	25	.47	3-11/16	2-5/16	2-5/16			
2" x 2" x 1-1/2"	05758	50	.41	3-1/8	1-15/16	2-3/16			
3" x 3" x 1-1/2"	05764	20	.85	2-11/16	1-3/4	2-9/16			
3" x 3" x 2"	05763	10	.96	3-5/16	2-1/8	2-7/8			
4" x 4" x 1-1/2"	05767	5	1.53	3-1/16	2	3-1/4			
4" x 4" x 2"	05765	10	1.47	3-3/16	2-1/16	3-5/16			
4" x 4" x 3"	05766	10	1.93	4-3/4	3	3-9/16			
6" x 6" x 4"	05768	5	4.28	5-13/16	3-5/8	4-5/16			

TEE • SANITARY • STREET

PVC DWV

P403

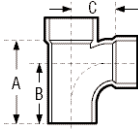

CONNECTION	CHARLOTTE STYLE	NIBCO STYLE	LASCO STYLE	Dimensions					
SP x H x H	403	4811-2	D403	A	B	C	D	E	F
Size	Part Number	Ctn Qty	Approx Net Wt.						
1-1/2"	06112	20	.29	3-7/16	2-7/16	1-3/4			
2"	06113	25	.46	4-7/16	3-1/16	2-5/16			
3"	06114	30	1.32	6-3/8	4-9/16	3-1/16			
4"	06120	10	2.34	7-7/8	5-5/8	3-7/8			

TEE • SANITARY • STREET • REDUCING

PVC DWV

P404

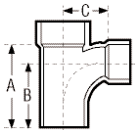

CONNECTION	CHARLOTTE STYLE	NIBCO STYLE	LASCO STYLE	Dimensions					
SP x H x H	404	4811-2	D404	A	B	C	D	E	F
Size	Part Number	Ctn Qty	Approx Net Wt.						
2" x 1-1/2" x 1-1/2"	06115	25	.38	3-7/8	2-11/16	2-3/16			
2" x 1-1/2" x 2"	06116	25	.46	4-7/16	3-1/16	2-5/16			
2" x 2" x 1-1/2"	06117	50	.39	3-7/8	2-11/16	2-3/16			
3" x 3" x 1-1/2"	06118	10	.79	4-3/16	3-1/4	2-9/16			
3" x 3" x 2"	06119	20	.88	4-13/16	3-5/8	2-7/8			
4" x 4" x 2"	06121	5	2.41	4-15/16	3-13/16	3-5/16			

TEE • SANITARY • W/LEFT SIDE INLET

PVC DWV

P416

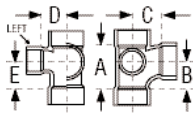

CONNECTION ALL HUB	CHARLOTTE STYLE 416	NIBCO STYLE 4871	LASCO STYLE D416					
Size	Part Number	Ctn Qty	Approx Net Wt.	Dimensions				
				A	B	C	D	E
3" x 3" x 3" x 1-1/2"	05781	10	1.46	4-7/8	3-1/16	3-1/16	2-9/16	3-11/16
3" x 3" x 3" x 2"	05782	10	1.57	4-7/8	3-1/16	3-1/16	2-7/8	3-11/16
4" x 4" x 4" x 2"	05784	5	2.61	6-1/8	3-7/8	3-7/8	3-5/16	4-3/16

TEE • SANITARY • W/RIGHT SIDE INLET

PVC DWV

P417

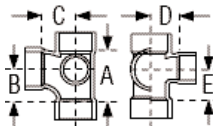

CONNECTION ALL HUB	CHARLOTTE STYLE 417	NIBCO STYLE 4872	LASCO STYLE D417					
Size	Part Number	Ctn Qty	Approx Net Wt.	Dimensions				
				A	B	C	D	E
3" x 3" x 3" x 1-1/2"	05795	10	1.46	4-7/8	3-1/16	3-1/16	2-9/16	3-11/16
3" x 3" x 3" x 2"	05796	10	1.57	4-7/8	3-1/16	3-1/16	2-7/8	3-11/16
4" x 4" x 4" x 2"	05797	5	2.54	6-1/8	3-7/8	3-7/8	3-5/16	4-3/16

TEE • SANITARY • DOUBLE • W/RIGHT & LEFT SIDE INLET

PVC DWV

P418

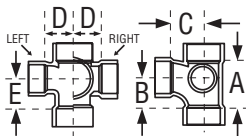

CONNECTION ALL HUB	CHARLOTTE STYLE 418	NIBCO STYLE 4870	LASCO STYLE D418					
Size	Part Number	Ctn Qty	Approx Net Wt.	Dimensions				
				A	B	C	D	E
3" x 3" x 3" x 1-1/2" x 1-1/2"	05810	10	1.61	4-7/8	3-1/16	3-1/16	2-9/16	3-11/16
3" x 3" x 3" x 2" x 2"	05811	5	1.76	4-7/8	3-1/16	3-1/16	2-7/8	3-11/16
4" x 4" x 4" x 1-1/2" x 1-1/2"	05805	5		4-7/8	3-7/8	3-5/8	7-5/8	4-7/8
4" x 4" x 4" x 2" x 2"	05808	5	2.78	6-1/8	3-7/8	3-7/8	3-5/16	5

TEE • SANITARY • DOUBLE

PVC DWV

P428

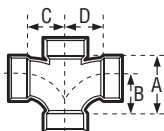

CONNECTION ALL HUB	CHARLOTTE STYLE 428	NIBCO STYLE 4835	LASCO STYLE D428					
Size	Part Number	Ctn Qty	Approx Net Wt.	Dimensions				
				A	B	C	D	E
1-1/2"	05812	25	.37	2-3/4	1-3/4	1-3/4	1-3/4	
2"	05813	20	.59	3-11/16	2-5/16	2-5/16	2-5/16	
3"	05814	20	1.74	4-7/8	3-1/16	3-1/16	3-1/16	
4"	05815	4	3.06	6-1/8	3-7/8	3-7/8	3-7/8	



TEE • SANITARY • DOUBLE • REDUCING

PVC DWV

P429

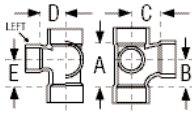

CONNECTION	CHARLOTTE STYLE	NIBCO STYLE	LASCO STYLE					
ALL HUB	429	4835	D429					
Size	Part Number	Ctn Qty	Approx Net Wt.	Dimensions				
				A	B	C	D	E
2" x 2" x 1-1/2" x 1-1/2"	05817	20	.50	3-1/8	1-15/16	2-3/16	2-3/16	
3" x 3" x 1-1/2" x 1-1/2"	05818	20	.88	2-11/16	1-3/4	2-9/16	2-9/16	
3" x 3" x 2" x 2"	05820	10	1.04	3-5/16	2-1/8	2-7/8	2-7/8	
4" x 4" x 2" x 2"	05240	5	1.49	3-3/16	2-1/16	3-5/16	3-5/16	
4" x 4" x 3" x 3"	05821	5	2.20	4-3/4	3	3-9/16	3-9/16	

TEE • SANITARY • DOUBLE • STREET • REDUCING

PVC DWV

P431

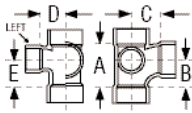

CONNECTION	CHARLOTTE STYLE	NIBCO STYLE	LASCO STYLE					
SP x H x H x H	431	N/A	D431					
Size	Part Number	Ctn Qty	Approx Net Wt.	Dimensions				
				A	B	C	D	E
3" x 3" x 2" x 2"	06310	10	.98	4-13/16	3-5/8	2-7/8		

TEE • SANITARY • DOUBLE • W/SIDE INLET

PVC DWV

P438

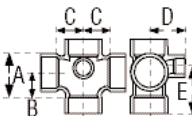

CONNECTION	CHARLOTTE STYLE	NIBCO STYLE	LASCO STYLE					
ALL HUB	438	4835-9	D438					
Size	Part Number	Ctn Qty	Approx Net Wt.	Dimensions				
				A	B	C	D	E
3" x 3" x 3" x 3" x 2"	05772	10	1.88	4-7/8	3-1/16	3-1/16	2-7/8	3-1/16

TEE • SANITARY • DOUBLE • W/RIGHT & LEFT SIDE INLET

PVC DWV

P439

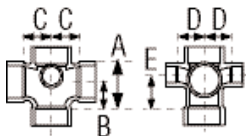

CONNECTION	CHARLOTTE STYLE	NIBCO STYLE	LASCO STYLE					
ALL HUB	439	4835-9-9	D439					
Size	Part Number	Ctn Qty	Approx Net Wt.	Dimensions				
				A	B	C	D	E
3" x 3" x 3" x 3" x 2" x 2"	05770	10	2.05	4-7/8	3-1/16	3-1/16	2-7/8	3-11/16

TEE • VENT

PVC DWV

P441

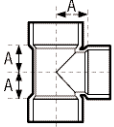

CONNECTION ALL HUB	CHARLOTTE STYLE 441	NIBCO STYLE 4811-Y	LASCO STYLE D441					
Size	Part Number	Ctn Qty	Approx Net Wt.	Dimensions				
				A	B	C	D	E
1-1/2"	06403	25	.26	1-3/16				
2"	06404	25	.40	1-1/2				
3"	06405	10	1.09	1-7/8				
4"	06406	5	1.96	2-1/2				

TEE • CLEANOUT • W/C.O. PLUG

PVC DWV

P444X

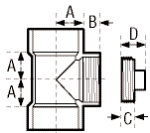

CONNECTION H x H x FPT	CHARLOTTE STYLE 444-X	NIBCO STYLE 4814	LASCO STYLE D-443					
Size	Part Number	Ctn Qty	Approx Net Wt.	Dimensions				
				A	B	C	D	E
1-1/2"	05997	10	.34	1-3/16	5/8	5/8	1-3/8	
2"	05998	10	.49	1-1/2	5/8	5/8	1-3/8	
3"	05999	10	1.24	1-7/8	3/4	3/4	1-3/4	
4"	06000	5	2.30	2-1/2	7/8	7/8	1-7/8	

TEE • FLUSH CLEANOUT

PVC DWV

P445

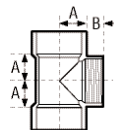

CONNECTION H x H x FPT	CHARLOTTE STYLE 445	NIBCO STYLE 4811-14-V	LASCO STYLE D445					
Size	Part Number	Ctn Qty	Approx Net Wt.	Dimensions				
				A	B	C	D	E
1-1/2"	06413	20	.27	1-3/16	5/8			
2"	06414	20	.39	1-1/2	5/8			
3"	06415	10	1.07	1-7/8	3/4			
4"	06416	10	1.96	2-1/2	7/8			

TEE • FLUSH CLEANOUT • W/FLUSH C.O. PLUG

PVC DWV

P445X

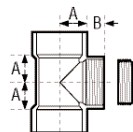

CONNECTION H x H x FPT	CHARLOTTE STYLE 445X	NIBCO STYLE N/A	LASCO STYLE N/A					
Size	Part Number	Ctn Qty	Approx Net Wt.	Dimensions				
				A	B	C	D	E
2"	05198	10	.39	1-1/2	5/8			
3"	05199	10	1.07	1-7/8	3/4			
4"	05200	5	1.96	2-1/2	7/8			



TEE • HORIZONTAL TWIN

PVC DWV

P447

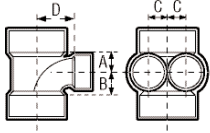

CONNECTION H x H x FPT	CHARLOTTE STYLE 447	NIBCO STYLE N/A	LASCO STYLE N/A					
Size	Part Number	Ctn Qty	Approx Net Wt.	Dimensions				
			A	B	C	D	E	
3" x 3" x 1-1/2" x 1-1/2"	05235	5	7/8	1-3/4	1-3/32	2-9/16		

TEE • TWO-WAY • CLEANOUT

PVC DWV

P448

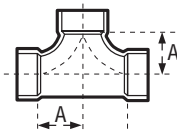
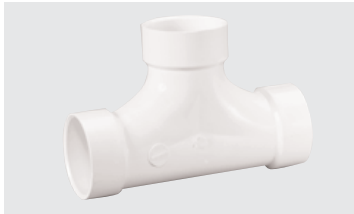

CONNECTION ALL HUB	CHARLOTTE STYLE 448	NIBCO STYLE 4811-C	LASCO STYLE D448					
Size	Part Number	Ctn Qty	Approx Net Wt.	Dimensions				
			A	B	C	D	E	
3"	05237	10	1.97	4-1/16				
4"	05238	5	3.46	4-15/16				

WYE • DOUBLE FIXTURE

PVC DWV

P500

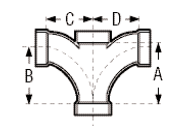

CONNECTION ALL HUB	CHARLOTTE STYLE 500	NIBCO STYLE 4835-B	LASCO STYLE D510					
Size	Part Number	Ctn Qty	Approx Net Wt.	Dimensions				
			A	B	C	D	E	
2"	05246	25	.83	4-5/8	4-1/4	3-1/2	3-1/2	
3"	05249	5	2.63	6-3/4	6-1/4	4-15/16	4-15/16	
REDUCING								
2" x 1-1/2" x 1-1/2" x 1-1/2"	05247	20	.60	3-1/2	3-1/8	2-7/8	2-7/8	
2" x 2" x 1-1/2" x 1-1/2"	05244	20	.64					
3" x 2" x 3" x 3"	05250	5	3.00	6-3/4	6-1/4	4-15/16	4-15/16	

WYE • COMBINATION • 1/8 BEND • ONE PIECE

PVC DWV

P501

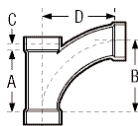

CONNECTION ALL HUB	CHARLOTTE STYLE 501	NIBCO STYLE 4812-LR	LASCO STYLE D501					
Size	Part Number	Ctn Qty	Approx Net Wt.	Dimensions				
			A	B	C	D	E	
1-1/2"	05853	50	.44	3-1/2	3-15/16	7/16	3-15/16	
2"	05858	20	.64	4-7/16	5-1/8	1-1/16	5-1/8	
3"	05852	10	2.25	6-1/2	7-9/16	1-1/16	7-9/16	
4"	05860	10	4.21	8-1/2	10	1-1/2	10	

WYE • COMBINATION • 1/8 BEND • REDUCING • ONE PIECE

PVC DWV

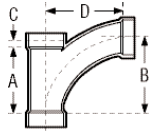

P502

CONNECTION	CHARLOTTE STYLE	NIBCO STYLE	LASCO STYLE					
ALL HUB	502	4812-LR	D502					
Size	Part Number	Ctn Qty	Approx Net Wt.	Dimensions				
				A	B	C	D	E
2" x 1-1/2" x 1-1/2"	05835	5	.24	3-1/2	3-15/16	7/16	4-3/16	
2" x 1-1/2" x 2"	05836	5	.73	4-7/16	5-1/8	11/16	5-1/8	
2" x 2" x 1-1/2"	05865	20	.53	3-1/2	3-15/16	7/16	4-3/16	
3" x 3" x 1-1/2"	05837	15	1.04	3-1/2	3-15/16	7/16	4-3/4	
3" x 3" x 2"	05857	10	1.21	4-7/16	5-1/8	11/16	5-11/16	
4" x 4" x 2"	05863	5	1.86	4-1/2	5-1/8	5/8	6-1/8	
4" x 4" x 3"	05864	5	2.85	6-1/2	7-9/16	1-1/16	8-1/16	

WYE • COMBINATION • 1/8 BEND • TWO PIECE

PVC DWV

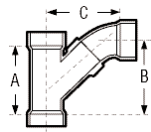

P503

CONNECTION	CHARLOTTE STYLE	NIBCO STYLE	LASCO STYLE					
ALL HUB	503	N/A	D503					
Size	Part Number	Ctn Qty	Approx Net Wt.	Dimensions				
				A	B	C	D	E
6"	05266	2	11.32	10	12-1/2	13-7/8		

WYE • COMBINATION • 1/8 BEND • REDUCING • TWO PIECE

PVC DWV

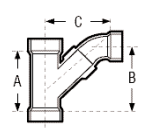

P504

CONNECTION	CHARLOTTE STYLE	NIBCO STYLE	LASCO STYLE					
ALL HUB	504	N/A	D504					
Size	Part Number	Ctn Qty	Approx Net Wt.	Dimensions				
				A	B	C	D	E
6" x 6" x 4"	05267	4	6.59	7	8-1/8	10		

WYE • COMBINATION • 1/8 BEND • DOUBLE • ASSEMBLY

PVC DWV

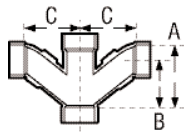
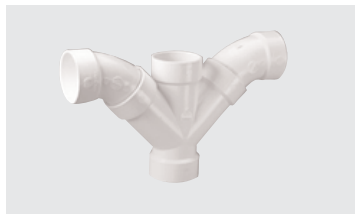

(THREE PIECE)

P507

CONNECTION	CHARLOTTE STYLE	NIBCO STYLE	LASCO STYLE					
ALL HUB	507	4836	D507					
Size	Part Number	Ctn Qty	Approx Net Wt.	Dimensions				
				A	B	C	D	E
3"	06032	10	3.86	6-1/2	7-3/8	7-3/8		
4"	06033	4	6.83	8	9-3/8	9-3/8		



TUBE & PIPE

METAL FITTINGS & NIPPLES

PLASTIC FITTINGS

VALVES

FILTER-DRIERS & STRAINERS

WYE • COMBINATION • 1/8 BEND • W/LEFT SIDE INLET

PVC DWV

P515

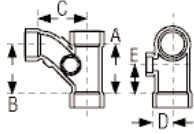

(TWO PIECE)

CONNECTION	CHARLOTTE STYLE	NIBCO STYLE	LASCO STYLE					
ALL HUB	515	N/A	N/A					
Size	Part Number	Ctn Qty	Approx Net Wt.	Dimensions				
3" x 3" x 3" x 2"	06009	10	2.64	6-5/8	7-1/2	7-1/2	2-1/16	4-1/4

WYE • COMBINATION • 1/8 BEND • W/RIGHT SIDE INLET

PVC DWV

P516

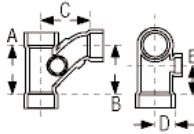

(TWO PIECE)

CONNECTION	CHARLOTTE STYLE	NIBCO STYLE	LASCO STYLE					
ALL HUB	516	N/A	N/A					
Size	Part Number	Ctn Qty	Approx Net Wt.	Dimensions				
3" x 3" x 3" x 2"	06008	10	2.59	6-5/8	7-1/2	7-1/2	2-1/16	4-1/4

WYE

PVC DWV

P600

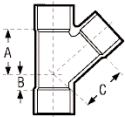

CONNECTION	CHARLOTTE STYLE	NIBCO STYLE	LASCO STYLE					
ALL HUB	600	4810	D600					
Size	Part Number	Ctn Qty	Approx Net Wt.	Dimensions				
1-1/4"	05816	35	.31	2-9/16	1-1/16	2-9/16		
1-1/2"	05822	50	.39	2-7/8	1-1/8	2-7/8		
2"	05823	25	.60	3-5/8	1-3/8	3-5/8		
3"	05824	25	1.72	5	1-5/8	5		
4"	05825	5	3.14	63/8	1-7/8	6-3/8		
6"	06135	4	6.66	8-7/16	1-3/4	8-7/16		
8"	06139	1	14.70	11-3/4	2-3/8	11-3/4		

WYE • REDUCING

PVC DWV

P601

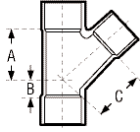

CONNECTION ALL HUB	CHARLOTTE STYLE 601	NIBCO STYLE 4810	LASCO STYLE D601					
Size	Part Number	Ctn Qty	Approx Net Wt.	Dimensions				
				A	B	C	D	E
2" x 1-1/2" x 1-1/2"	05831	25	.47	2-13/16	3/4	2-15/16		
2" x 1-1/2" x 2"	05832	50	.66	3/2	1	3-3/8		
2" x 2" x 1-1/2"	05826	25	.52	3-5/16	1-1/16	3-7/16		
3" x 3" x 1-1/2"	05827	15	1.07	3-3/4	1/2	4-5/16		
3" x 3" x 2"	05828	25	1.17	4-1/8	7/8	4-5/8		
4" x 4" x 1-1/2"	05833	5	1.89	3-5/16	0	3-15/16		
4" x 4" x 2"	05829	10	1.86	4-11/16	3/8	5-9/16		
4" x 4" x 3"	05830	10	2.41	5-9/16	1-1/16	6		
6" x 6" x 3"	06138	5	5.01	6-15/16	3/16	7-7/16		
6" x 6" x 4"	06137	5	5.01	6-11/16	3/16	7-7/16		
8" x 8" x 6"	05834	1	10.72	9-1/2	1	9-13/16		

WYE • STREET

PVC DWV

P602

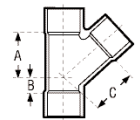

CONNECTION SP x H x H	CHARLOTTE STYLE 602	NIBCO STYLE 4810-2	LASCO STYLE D602					
Size	Part Number	Ctn Qty	Approx Net Wt.	Dimensions				
				A	B	C	D	E
1-1/2"	06367	50	.38	2-7/8	1-13/16	2-7/8		
2"	06368	30	.56	3-5/8	2-1/8	3-5/8		
3"	06369	10	1.66	5	3-1/8	5		
4"	06370	5	2.98	6-3/8	3-5/8	6-3/8		

WYE • STREET • REDUCING

PVC DWV

P603

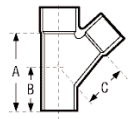

CONNECTION SP x H x H	CHARLOTTE STYLE 603	NIBCO STYLE 4810-2	LASCO STYLE D603						
Size	Part Number	Ctn Qty	Approx Net Wt.	Dimensions					
				A	B	C	D	E	F
3" x 3" x 1-1/2"	06372	20	1.02	3-3/4	2	4-5/16			
3" x 3" x 2"	06373	30	1.11	4-1/8	2-3/8	4-5/8			
4" x 4" x 2"	06374	10	1.74	4-11/16	2-1/8	5-9/16			
4" x 4" x 3"	06375	10	2.30	5-9/16	2-13/16	6			

TUBE & PIPE

METAL FITTINGS & NIPPLES

PLASTIC FITTINGS

VALVES

FILTER-DRIERS & STRAINERS

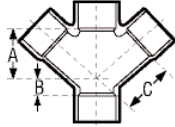

WYE • DOUBLE**PVC DWV****P611**

CONNECTION ALL HUB	CHARLOTTE STYLE 611	NIBCO STYLE 4834	LASCO STYLE D611					
Size	Part Number	Ctn Qty	Approx Net Wt.	Dimensions A B C D E				
1-1/2"	05838	40	.49	2-7/8	1-1/8	2-7/8		
2"	05839	20	.78	3-5/8	1-3/8	3-5/8		
3"	05840	10	2.17	5	1-5/8		5	
4"	05841	5	3.83	6-3/8	1-7/8	6-3/8		
6"	05842	2	5.00	8-7/16	1-3/4	8-7/16		

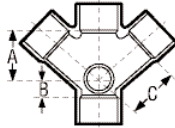
WYE • DOUBLE • W/SIDE INLET**PVC DWV****P611S**

CONNECTION ALL HUB	CHARLOTTE STYLE 611-S	NIBCO STYLE N/A	LASCO STYLE D610					
Size	Part Number	Ctn Qty	Approx Net Wt.	Dimensions A B C D E				
3" x 3" x 3" x 3" x 2"	05849	10	2.23					

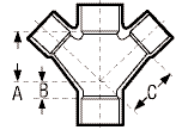
WYE • DOUBLE • REDUCING**PVC DWV****P612**

CONNECTION ALL HUB	CHARLOTTE STYLE 612	NIBCO STYLE 4834	LASCO STYLE D612					
Size	Part Number	Ctn Qty	Approx Net Wt.	Dimensions A B C D E				
2" x 2" x 1-1/2" x 1-1/2"	05847	10	.63	3-5/16	1-1/16	3-7/16		
3" x 3" x 1-1/2" x 1-1/2"	05843	10	1.13	3-3/4	1/2	4-5/16		
3" x 3" x 2" x 2"	05844	10	1.35	4-1/8	7/8	4-5/8		
4" x 4" x 2" x 2"	05845	5	2.00	4-11/16	3/8	5-9/16		
4" x 4" x 3" x 3"	05846	5	2.93	5-9/16	1-1/16	6		
6" x 6" x 4" x 4"	06142	3	5.71	6-11/16	3/16	7-7/16		

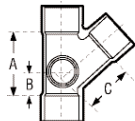
WYE • W/LEFT SIDE INLET**PVC DWV****P625**

CONNECTION ALL HUB	CHARLOTTE STYLE 625	NIBCO STYLE N/A	LASCO STYLE D625					
Size	Part Number	Ctn Qty	Approx Net Wt.	Dimensions A B C D E				
3" x 3" x 3" x 2"	06155	5	1.99	6-1/2	2-3/16	5		
4" x 4" x 4" x 2"	06157	5	3.53	8	2-1/2	6-3/16		

WYE • W/RIGHT SIDE INLET

PVC DWV

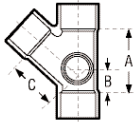
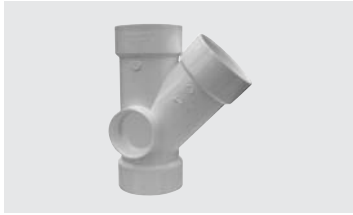

P626

CONNECTION ALL HUB	CHARLOTTE STYLE 626	NIBCO STYLE N/A	LASCO STYLE D625	Dimensions				
Size	Part Number	Ctn Qty	Approx Net Wt.	A	B	C	D	E
3" x 3" x 3" x 2"	06156	5	1.99	6-1/2	2-3/16	5		
4" x 4" x 4" x 2"	06158	5	3.53	8	2-1/2	6-3/16		

RETURN BEND

PVC DWV

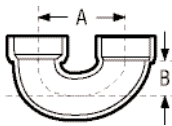

P700

CONNECTION H x H	CHARLOTTE STYLE 700	NIBCO STYLE 4879	LASCO STYLE D700	Dimensions					
Size	Part Number	Ctn Qty	Approx Net Wt.	A	B	C	D	E	F
1-1/2"	06466	20	.34	3-1/2	1-17/32				
2"	06467	35	.60	5-1/4	2-3/8				
3"	06468	10	1.77	6-3/4	3				
4"	06469	5	3.13	8-9/16	3-11/16				

RETURN BEND • W/CLEANOUT

PVC DWV

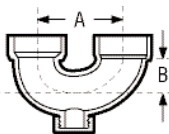

P701

CONNECTION H x H	CHARLOTTE STYLE N/A	NIBCO STYLE 4878	LASCO STYLE N/A	Dimensions					
Size	Part Number	Ctn Qty	Approx Net Wt.	A	B	C	D	E	F
1-1/2"	06471	20	.36	3-1/16	1-3/8				
2"	06472	10	.67	5-1/32	2-1/4				

ADAPTER • TAIL PIECE • W/PLASTIC NUT

PVC DWV

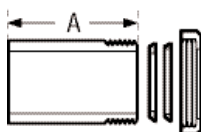

P704P

CONNECTION SP x SJ	CHARLOTTE STYLE 704-P	NIBCO STYLE N/A	LASCO STYLE N/A	Dimensions					
Size	Part Number	Ctn Qty	Approx Net Wt.	A	B	C	D	E	F
1-1/2" x 1-1/2"	05975	25	.13	2-5/8					
OR									
1-1/2" x 1-1/4"	05975	25	.13	2-5/8					

(FURNISHED W/BOTH SIZE SJ WASHERS)

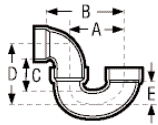
P - TRAP • W/SOLVENT WELD JOINT**PVC DWV****P706X**

CONNECTION H x H	CHARLOTTE STYLE 706-P	NIBCO STYLE 4885	LASCO STYLE D706					
Size	Part Number	Ctn Qty	Approx Net Wt.	Dimensions				
				A	B	C	D	E
1-1/2"	05214	25	.51	3-1/2	4-23/32	2-11/32	3-5/8	1-17/32
2"	05222	20	.87	5-1/4	6-7/8	2-7/8	5-1/8	2-3/8
3"	05230	10	2.75	6-3/4	9-15/16	4-11/16	7-5/8	3
4"	05231	4	4.88	8-9/16	12-7/16	5-1/4	7-9/16	3-11/16

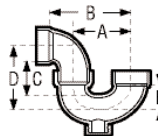
P - TRAP • W/SOLVENT WELD JOINT & CLEANOUT**PVC DWV****P707X**

CONNECTION H x H	CHARLOTTE STYLE 707-X	NIBCO STYLE 4884	LASCO STYLE D707					
Size	Part Number	Ctn Qty	Approx Net Wt.	Dimensions				
				A	B	C	D	E
1-1/2"	05223	10	.55	3-1/16	4-9/32	2-1/8	3-5/8	1-3/8
2"	05224	10	.88	5-1/32	6-3/8	2-1/2	5	2-1/4

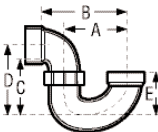
P-TRAP • W/UNION**PVC DWV****P708P**

CONNECTION H x H	CHARLOTTE STYLE 708-P	NIBCO STYLE 4895	LASCO STYLE D708					
Size	Part Number	Ctn Qty	Approx Net Wt.	Dimensions				
				A	B	C	D	E
1-1/4"	05921	50	.48	3	4-1/8	2-1/16	3-3/8	1-3/8
1-1/2"	05215	25	.57	3-1/2	4-23/32	2-11/32	3-5/8	1-17/32
2"	05216	20	.94	5-1/4	6-7/8	2-7/8	5-1/8	2-3/8

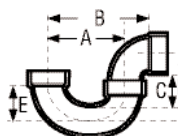
P-TRAP • LOW PROFILE • W/SOLVENT WELD JOINT**PVC DWV****P710**

CONNECTION H x H	CHARLOTTE STYLE N/A	NIBCO STYLE N/A	LASCO STYLE N/A					
Size	Part Number	Ctn Qty	Approx Net Wt.	Dimensions				
				A	B	C	D	E
2"	05225	20	.87	5-1/4	6-7/8	2-3/16	4-3/4	2-1/4

LATRAP W/UNION AND 1-1/2" & 1-1/4" SJ WASHERS • PLASTIC NUT

PVC DWV

P711P

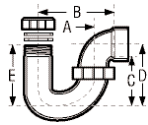

CONNECTION Sj x H	CHARLOTTE STYLE 711-P	NIBCO STYLE 4893	LASCO STYLE D711	Dimensions					
Size	Part Number	Ctn Qty	Approx Net Wt.	A	B	C	D	E*	F
1-1/4" x 1-1/2"	05220	25	.71	3-13/16	5	2-1/2	4	4	
AND 1-1/2" x 1-1/2"									

(FURNISHED W/BOTH SIZE SJ WASHERS) *TO TOP OF NUT

DRUM TRAP • W/CLEANOUT

PVC DWV

P720X

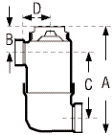

CONNECTION H x H	CHARLOTTE STYLE 720X	NIBCO STYLE 4891	LASCO STYLE D720	Dimensions					
Size	Part Number	Ctn Qty	Approx Net Wt.	A	B	C	D	E	F
1-1/2" x 3" x 6"	06100	10	1.29	7-13/16	3	4-1/2	1-1/2		

(W/PLUG)

CLOSET FLANGE

PVC DWV

P800

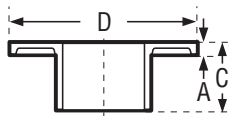

CONNECTION H	CHARLOTTE STYLE 800	NIBCO STYLE 4851	LASCO STYLE D800	Dimensions					
Size	Part Number	Ctn Qty	Approx Net Wt.	A	B	C	D	E	F
4"	05902	25	.68	7/16	-	2	7		

(ONE PIECE W/SLOTS)

CLOSET FLANGE • KNOCKOUT

PVC DWV

P800KO

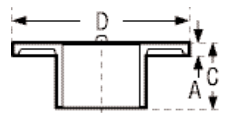

CONNECTION H	CHARLOTTE STYLE 800-KO	NIBCO STYLE 4855	LASCO STYLE D815	Dimensions					
Size	Part Number	Ctn Qty	Approx Net Wt.	A	B	C	D	E	F
4"	05253	25	.75	7/16	-	2	7		
4" x 3"	05254	25	.81	7/16	-	2	7		

(ONE PIECE W/SLOTS & KNOCKOUT TEST CAP)



TUBE & PIPE

METAL FITTINGS & NIPPLES

PLASTIC FITTINGS

VALVES

FILTER-DRYERS & STRAINERS

CLOSET FLANGE • W/STOP

PVC DWV

P800S

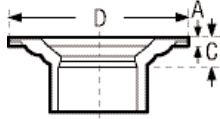
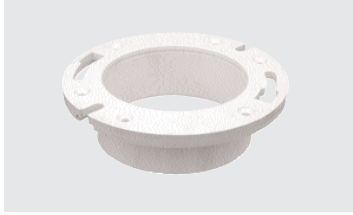

(ONE PIECE W/SLOTS)

CONNECTION	CHARLOTTE STYLE			NIBCO STYLE	LASCO STYLE					
H	800-S			N/A	N/A					
Size	Part Number	Ctn Qty	Approx Net Wt.	Dimensions						
				A	B	C	D	E	F	
4" x 3"	05903	25	.78	7/16	1-1/4	-	7			

CLOSET FLANGE • SPIGOT • REDUCING

PVC DWV

P801

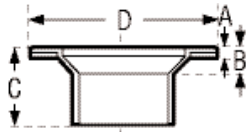
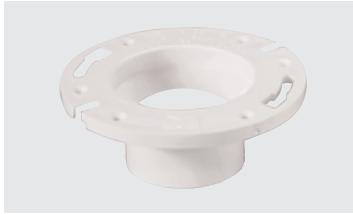

(ONE PIECE)

CONNECTION	CHARLOTTE STYLE			NIBCO STYLE	LASCO STYLE					
SP	801			4851-4	D801					
Size	Part Number	Ctn Qty	Approx Net Wt.	Dimensions						
				A	B	C	D	E	F	
4" x 3"	05919	25	.71	7/16	1-1/4	2-3/4	7			

CLOSET FLANGE • ADJUSTABLE • W/PLASTIC RING

PVC DWV

P810

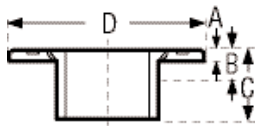
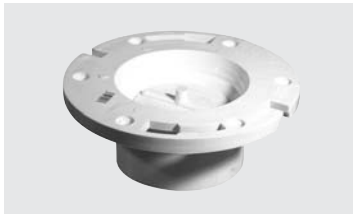

(W/SLOTS)

CONNECTION	CHARLOTTE STYLE			NIBCO STYLE	LASCO STYLE					
H	810			N/A	D810					
Size	Part Number	Ctn Qty	Approx Net Wt.	Dimensions						
				A	B	C	D	E	F	
4"	05256	25	.67	1/2	-	2-1/4	7			

CLOSET FLANGE • W/PIPE STOP ADJUSTABLE • W/PLASTIC RING

PVC DWV

P801

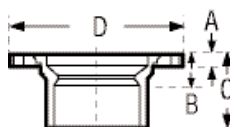
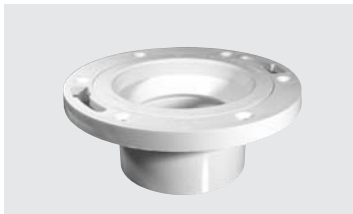

(W/SLOTS)

CONNECTION	CHARLOTTE STYLE			NIBCO STYLE	LASCO STYLE					
H	N/A			N/A	N/A					
Size	Part Number	Ctn Qty	Approx Net Wt.	Dimensions						
				A	B	C	D	E	F	
3" x 4"	05251	25	.80	1/2	1-1/4	2-3/4	7			

CLOSET FLANGE • ADJUSTABLE • W/METAL RING • EPOXY COATED PVC DWV

P811

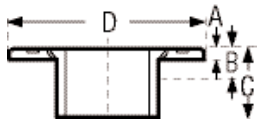

(W/SLOTS)

CONNECTION H	CHARLOTTE STYLE 811		NIBCO STYLE 4851-A		LASCO STYLE D811			
	Part Number	Ctn Qty	Approx Net Wt.	Dimensions				
Size				A	B	C	D	E F
4"	05226	25	.70	5/16	-	2	7	
4" x 3"	05227	25	.83	5/16	1-1/4	2-3/4	7	

CLOSET FLANGE • SPIGOT • ADJUSTABLE W/METAL RING • EPOXY COATED PVC DWV

P812

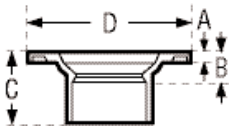

CONNECTION SP	CHARLOTTE STYLE 812		NIBCO STYLE 4851-2-A		LASCO STYLE D812			
	Part Number	Ctn Qty	Approx Net Wt.	Dimensions				
Size				A	B	C	D	E F
4" x 3"	05228	25	.76	5/16	1-1/4	2-1/4	7	
4"	05229	25	1.19	5/16	-	2-1/4	7	

CLOSET FLANGE • SPIGOT • ADJUSTABLE W/PLASTIC RING PVC DWV

P812P

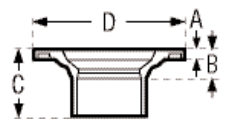

CONNECTION SP	CHARLOTTE STYLE N/A		NIBCO STYLE N/A		LASCO STYLE N/A			
	Part Number	Ctn Qty	Approx Net Wt.	Dimensions				
Size				A	B	C	D	E F
4" x 3"	05252	25	.72	1/2	1-1/4	2-3/4	7	
4"	05264	25	.75	1/2	-	2-1/4	7	

TUBE & PIPE

METAL FITTINGS & NIPLLES

PLASTIC FITTINGS

VALVES

FILTER-DRIERS & STRAINERS



CLOSET FLANGE • FLUSH

PVC DWV

P815

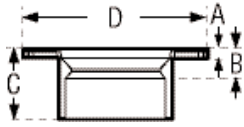

(FITS OVER 3" OR INSIDE 4" SCH. 40 DWV PIPE)

CONNECTION SP & H	CHARLOTTE STYLE 815	NIBCO STYLE 4853	LASCO STYLE N/A						
Size	Part Number	Ctn Qty	Approx Net Wt.	Dimensions					
				A	B	C	D	E	F
4" x 4" x 4" x 3"	05255	25	.64	1/2	1-1/4	2-3/4	7		

CLOSET FLANGE • FLUSH • KNOCKOUT

PVC DWV

P815KO

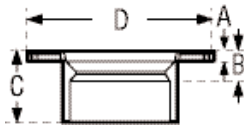
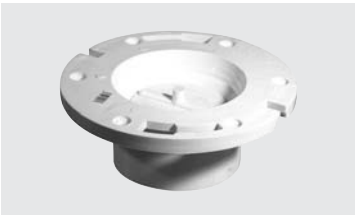

(FITS OVER 3" OR INSIDE 4" SCH. 40 DWV PIPE)

CONNECTION SP & H	CHARLOTTE STYLE 815KO	NIBCO STYLE 4853KO	LASCO STYLE D815						
Size	Part Number	Ctn Qty	Approx Net Wt.	Dimensions					
				A	B	C	D	E	F
4" x 4" x 4" x 3"	05257	25		1/2	1-1/4	2-3/4	7		

CLOSET FLANGE • OFFSET • ADJUSTABLE W/METAL RING • EPOXY COATED PVC DWV

P820

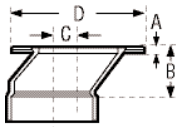

CONNECTION H	CHARLOTTE STYLE 820	NIBCO STYLE 4848-A	LASCO STYLE D823						
Size	Part Number	Ctn Qty	Approx Net Wt.	Dimensions					
				A	B	C	D	E	F
4" x 3"	05920	15	1.14	5/16	2-3/4	1-1/2	7		

Refrigeration Valves



Mueller is the known and trusted name in HVAC and Refrigeration products. Mueller's line of HVAC/ Refrigeration Valves, Valve Kits, and other components have been designed to provide optimum system performance and enhanced serviceability for many of today's applications. All valves are made to the highest quality and testing standards and incorporate many industry leading features and exclusive technologies only found in quality Mueller products. From wide operating temperature ranges and compatibility with the newer refrigerants and oils to forged brass bodies and full port openings, Mueller's expansive line of HVAC/Refrigeration products have the features that ensure the performance you expect.

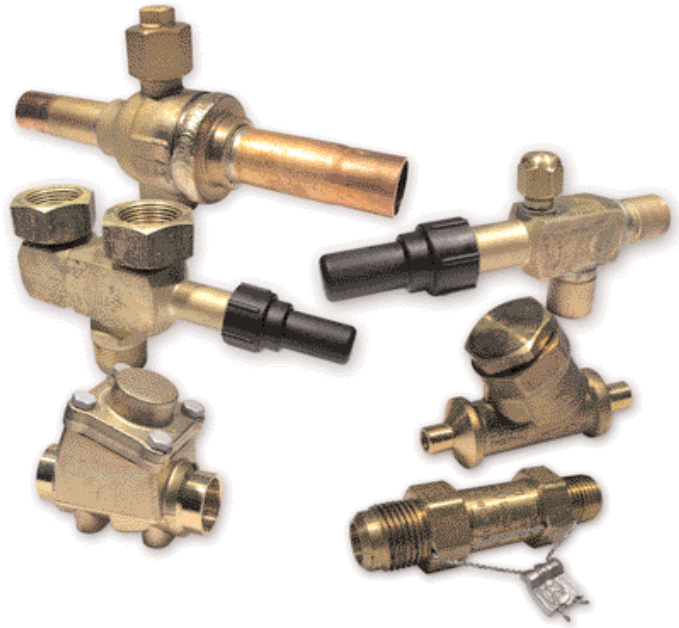

TUBE & PIPE

METAL FITTINGS & NIPPLES

PLASTIC FITTINGS

VALVES

FILTER-DRIERS & STRAINERS

CYCLEMASTER® ACTUATED BALL VALVES

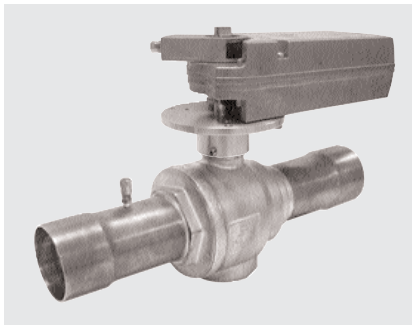

- Full port construction to match line size I.D.
- Quarter turn operation, with ball position indicated by arrow.
- Full shutoff capability.
- Dual pin stops.
- Gradual open/close stops line hammer.
- Chromium plated ball.
- Nylon anti-friction ring.
- Exclusive MCM™ leak-free seals.
- Compatible with all new refrigerant and oils.
- Remote operating capability.
- Removable actuator for quick change replacement.
- Manual override and valve positioning.
- Electronic overload protection.
- Models available with auxiliary switch.
- All valves 100% tested, UL/cUL listed and CE certified.

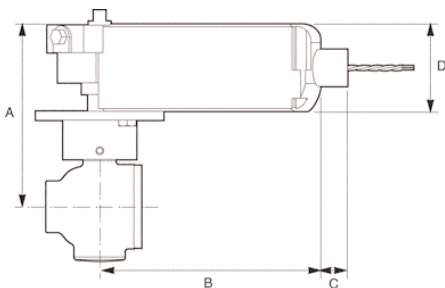

Straight						3-Way				
Size	Part No.	A	B	C	D	Part No.	A	B	C	D
1/2	AW17861	4.05	3.71	NA	2.69	AY17861	4.05	3.71	NA	2.69
5/8	AW17862	4.05	3.71	NA	2.69	AY17862	4.05	3.71	NA	2.69
3/4	AW17863	4.36	3.71	NA	2.69	AY17863	4.36	3.71	NA	2.69
7/8	AW17864	4.36	3.71	NA	2.69	AY17864	4.36	3.71	NA	2.69
1-1/8	AW17865	4.89	5.75	.65	3.18	AY17865	4.89	5.75	.65	3.18
1-3/8	AW17866	5.12	5.75	.65	3.18	AY17866	5.70	5.75	.65	3.18
1-5/8	AW17867	5.84	5.75	.65	3.18	AY17867	6.19	5.75	.65	3.18
2-1/8	AW17868	6.50	8.25	.67	3.93	A 17812	6.50	8.25	.67	3.93
2-5/8	AW17871	6.50	8.25	.67	3.93	A 17813	6.50	8.25	.67	3.93
3-1/8	AW17872	6.50	8.25	.67	3.93	A 17814	6.50	8.25	.67	3.93

Actuated Kits		
Size	Straight	3-Way
1/2	B 34437	B 34437
5/8	B 34437	B 34437
3/4	B 34438	B 34438
7/8	B 34438	B 34438
1 1/8	B 34439	B 34439
1 3/8	---	B 34440
1 5/8	B 34440	B 34441
2 1/8	B 34441	B 34442
2 5/8	B 34441	B 34442
3 1/8	B 34441	B 34442

Actuated Ball Valve Accessories		
Part No.	Accessory	For Use with Actuator
P 36532	Housing	Series II
P 36533	Heater	Series II
P 36534	Heated Housing	Series II
P 36535	Housing	Series III
P 36536	Heater	Series III
P 36537	Heated Housing	Series III



CYCLEMASTER® BALL VALVES

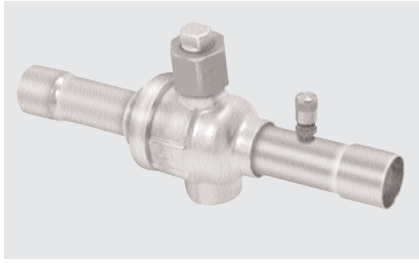

- Full port construction from sizes 1/4" through 3 1/8" to match line size I.D.
- Chromium plated ball reduces frictional wear; extends seal life and is an environmentally friendly component.
- Exclusive MCM™ seals that provide industry leading longevity and immeasurably low leak rates.
- Quick-turn cap provides visual identification of stem position and enhances serviceability in tight spaces.
- Flexible body forging that allows optional surface mount configuration.
- Dual pin stops.
- Optional features include access ports, drilled and tapped, one-piece seal caps and 3-way body styles.
- Compatible with all CFC, HCFC, and HFC refrigerants and oils.
- Wide operating temperature range of -40°F to 300°F, and working pressures up to 700 psig.
- All valves are 100% tested, UL/cUL listed and CE certified.

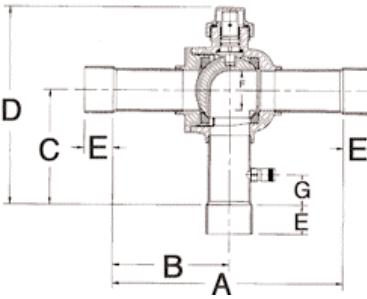
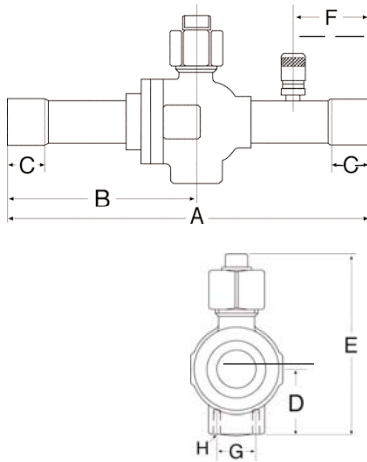

CYCLEMASTER® BALL VALVE

Part No.	Size	Cv	A (in)	B (in)	C (in)	D (in)	E (in)	F** (in)	G** (mm)	Port Size	H**	Wt.
A 17859*	1/4	1.02	5-7/16	2-15/16	5/16	7/8	2-3/4	NA	14	1/2	M4 X 0.7	.70
A 17860*	3/8	4.29	5-1/2	3	5/16	7/8	2-3/4	15/16	14	1/2	M4 X 0.7	.63
A 17861*	1/2	6.20	6-3/8	3-7/16	3/8	7/8	2-3/4	1-3/16	14	1/2	M4 X 0.7	.62
A 17862*	5/8	11.20	6-3/8	3-7/16	1/2	7/8	2-3/4	1-3/8	14	1/2	M4 X 0.7	.64
A 17863	3/4	18.95	7-7/16	3-7/8	5/8	1-1/4	3-1/2	1-1/2	20	3/4	M4 X 0.7	1.15
A 17864	7/8	29.30	7-7/16	3-7/8	3/4	1-1/4	3-1/2	1-5/8	20	3/4	M4 X 0.7	1.53
A 17865	1-1/8	59.55	8-7/16	4-5/16	7/8	1-9/16	3-13/16	1-3/4	25	1	M4 X 0.7	2.92
A 17866	1-3/8	84.58	10	5	1	1-1/2	4-3/16	2-1/16	30	1-1/4	M6 X 1.0	3.48
A 17867	1-5/8	225.04	11	5-1/2	1-1/8	1-11/16	4-7/8	2-1/4	34	1-1/2	M6 X 1.0	5.02
A 17868	2-1/8	291.59	12	6	1-3/8	2-1/8	5-9/16	2-7/16	34	2	M6 X 1.0	8.60
A 17869	2-5/8	423.47	13-1/2	6-13/16	1-1/2	***	***	***	34	2-9/20	M6 X 1.0	14.00
A 17870	3-1/8	***	16	8	1-3/8	3	7-3/8	3-1/8	34	3	M6 X 1.0	23.50
A 17871*	2-5/8	184.85	12	6	1-3/8	2-1/8	5-5/8	2-3/8	34	2	M6 X 1.0	9.20
A 17872*	3-1/8	127.99	12	6	1-11/16	2-1/8	5-5/8	3-1/16	34	2	M6 X 1.0	11.00

CYCLEMASTER® 3-WAY BALL VALVE WITH ACCESS PORTS

Part No.	Size	Cv	A (in)	B (in)	C (in)	D (in)	E (in)	F** (in)	G** (in)	Wt.
AU17860	3/8	2.23	4-7/8	2-21/32	2-19/64	3-21/32	5/16	1/2	41/64	.67
AU17861	1/2	3.94	5-3/8	3-3/64	2-43/64	4-7/32	3/8	1/2	53/64	.70
AU17862	5/8	4.63	5-3/8	2-59/64	2-35/64	4-7/64	1/2	1/2	27/32	.70
AU17863	3/4	11.90	6-1/4	3-57/64	3	5-1/4	5/8	3/4	55/64	NA
AU17864	7/8	10.89	5-31/32	3-5/32	2-29/32	4-7/8	3/4	3/4	27/32	1.44
AU17865	1-1/8	19.33	6-39/64	3-31/16	3-7/64	5-31/64	29/32	1	53/64	2.76
A 17545	1-3/8	31.06	8-1/16	4-7/64	3-61/64	6-57/64	3-1/32	1-1/4	1-5/64	4.97
A 17546	1-5/8	44.69	8-7/8	4-7/16	4-23/64	7-33/64	1-3/32	1-1/2	1-5/32	7.17
A 17547	2-1/8	76.32	9-5/16	4-39/64	4-23/32	8-13/32	1-11/32	2	1-5/64	13.80
A 17548	2-5/8	69.85	9-1/16	4-15/32	4-19/32	8-9/32	1-15/32	2	1-1/64	14.66
A 17549	3-1/8	58.19	8-11/16	4-9/32	4-11/32	8-3/32	1-21/32	2	1-27/64	15.48

BALL VALVE
SEAL CAP KIT****

Part No.	Size
A 17842	1/4
A 17842	3/8
A 17842	1/2
A 17842	5/8
A 17843	3/4
A 17843	7/8
A 17844	1-1/8
A 17845	1-5/8
A 17845	2-1/8
A 17846	2-5/8
A 17846	3-1/8
A 17845	2-5/8
A 17845	3-1/8

Prefixed for Ball Valve Options:

- A= Standard
- AC= Standard with access
- AP= Drilled & tapped
- APM= Drilled & tapped with 1-piece seal cap
- AQ= Drilled & tapped with access
- AQM= Drilled & tapped with access & 1-piece seal cap
- AU= 3-Way with access

Examples:

- A 17865**, 1-1/8" without access
- AC17865**, 1-1/8" with access
- AP17865**, 1-1/8" drilled & tapped
- APM17865**, 1-1/8" drilled & tapped with 1-piece seal cap
- AQ17865**, 1-1/8" drilled & tapped with access
- AQM17865**, 1-1/8" drilled & tapped with access & 1-piece seal cap
- AU17865**, 1-1/8" 3-way with access

* Reduced port

** Where Applicable

*** Consult factory for details

**** Seal Cap Kit Includes Seal Cap, Seal Cap Gasket, Anti-Friction Ring, Cap Nut

• Sizes not available in "Standard, A" or "Standard with Access, AC" options. Substitute "AP" for "A" and "AQ" for "AC".

PACKED LINE VALVES



- Non-backseating service valves.
- Forged brass body with integral mounting bracket.
- Plated steel stem suitable for refrigerants and other industrial fluids non-corrosive to brass and steel.
- Asbestos-free stem packing material.
- Maximum temperature rating at +300°F.
- UL recognized

ANGLE NON-BACKSEATING-INTERNAL SWIVEL FLARE

Part No. w/ Steel Cap	Part No. w/ Plastic Cap	Part No. w/ Brass Cap**	Internal Flare A	Flare B	C	D	E	Wt./ Ea.	MWP
B 33803	A 17429	B 34247	1/4	1/4	1-15/32	1-1/16	3 29/32	.33	700
A 17474	-----	B 34261	3/8	3/8	1-1/2	1-1/8	3 9/16	.27	700

** Copper gasket included.
One soft gasket included with each assembly

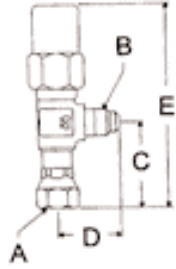

ANGLE NON-BACKSEATING-NPTFE INLET TO FLARE†

Part No. w/ Steel Cap	Part No. w/ Brass Cap**	Size		Counterbore Dimensions (F ³)				Wt./ Ea.	MWP	
		MPT A	Flare B	C	D	E	Dia.			Depth
A 11031	A 16472	1/4	1/4	1	15/16	3-3/64	.254	5/16	.26	700
A 11030		1/4	3/8	1-1/16	1-1/8	3-3/32	.317	3/8	.31	700
A 13613		3/8	1/4	1-1/8	1-1/16	3-3/16	.379	3/8	.31	700
A 13503		3/8	3/8	1-1/8	1-1/8	3-5/32	.379	5/16	.33	700
A 11042		3/8	1/2	1-3/8	1-3/8	3-3/4	.379	3/8	.51	700

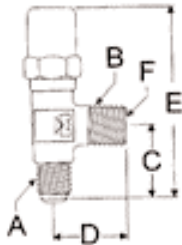

ANGLE NON-BACKSEATING-NPTFE FLARE TO NPTFE

Part No. w/ Steel Cap	Part No. w/ Brass Cap**	Size			Counterbore Dimensions (F ³)		Wt./Ea.	MWP
		C	D	E	Dia.	Depth		
A 15073		15/16	1	3	.254	3/8	.27	

* Machined to accept O.D. size tube as indicated.

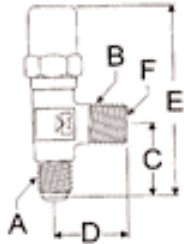

ANGLE NON-BACKSEATING-SOLDER TO FLARE WITH SEAL CAP

Part No. W/ Steel Cap	Part No. W/ Brass Cap***	Part No. Loosely Assembled	C	D	E	F	Wt./Ea.	MWP
A 17502	B 34252	B 35161	2-3/32	1-1/32	2 3/4	3/8	.58	700
A 17503	B 34255	B 35160	1-1/16	1-1/2	2-23/32	1/2	.49	700

* Also 3/8 FTG. **Also 1/2 FTG.
*** Copper gasket included.

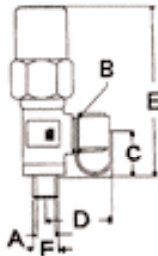

ANGLE BACKSEATING-NPTFE INLET TO SOLDER

Part No.	C	D	E	Counterbore Dimensions (F ³)		Wt./Ea.	MWP
				Dia.	Depth		
A 13977	1-13/16	1	4-3/32	.504	3/8	.51	500
A 13978	1-13/16	1	4-11/16	.504	3/8	.61	500
A 13979	2-3/32	1	6	.754	5/8	1.27	700

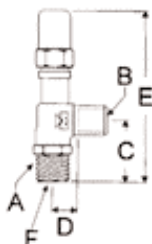

PACKED LINE VALVES

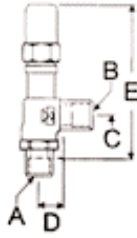

ANGLE BACKSEATING-SOLDER TO SOLDER

Part No.	A	B	C	D	E	Wt./Ea.	MWP
A 17506	5/8	5/8	29/32	1	3-3/4	.66	500
B 32080	7/8	7/8	2-9/32	1-3/4	6-13/64	.99	700

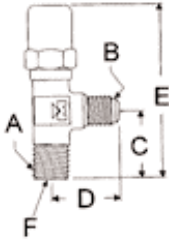

ANGLE BACKSEATING-NPTFE INLET TO FLARE

Part No.	Size		C	D	E	Counterbore Dimensions (F [†])		Wt./Ea.	MWP
	NPTFE	Flare				Di.	Depth		
A 13220	1/2	1/2	1 13/16	1-5/16	4-1/8	.504	3/8	.53	500
A 13183	1/2	5/8	1 13/16	1-1/2	4-11/16	.504	3/8	.64	500

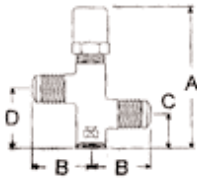

TWO WAY-FLARE TO FLARE

Part No. W/ Steel Cap	Part No. W/ Brass Cap*	Size	A	B	C	D	Wt./ Ea.	MWP
A 13591	B 33482	1/4	3-13/32	1	29/32	1-13/32	.50	500
A 13595		3/8	3-13/32	1-1/8	29/32	1-13/32	.55	500
A 13592		1/2	3-13/32	1-1/4	15/16	1-7/16	.56	500

* Copper gasket included

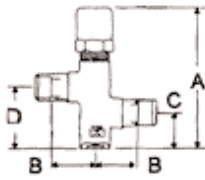

TWO WAY-SOLDER TO SOLDER

Part No. W/ Steel Cap	Part No. W/ Brass Cap*	Size	A	B	C	D	Wt./ Ea.	MWP
A 15580	B 34883	1/4	3-13/32	3/4	15/16	1-7/16	.49	500
A 15581		3/8	3-13/32	15/16	29/32	1-13/32	.51	500
A 15582		1/2	3-13/32	7/8	29/32	1-13/32	.52	500

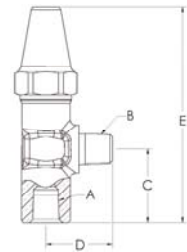

ANGLE NON-BACKSEATING

Part No.	A	B	C	D	E	MWP
A 13502	1/4 NPTFE	1/4 NPTF†	1-3/8	1-1/16	3-25/32	700
B 32222	1/4 NPTF†	1/4 NPTFE	1-1/4	1-1/8	3-43/64	500

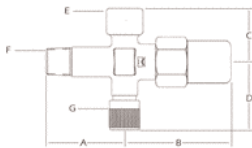

TRANSDUCER VALVE

Part No.	A	B	C	D	E	F	G	Stem Cap Material	Valve Core Installed	Loosely Assembled	MWP
B 33837	1-1/2	2	1	1-1/4	1/8 NPTF†	1/4 NPTFE	1/4 Flare Access	Steel	No	No	700
B 34254	1-1/2	2	1	1-1/4	1/8 NPTF†	1/4 NPTFE	1/4 Flare Access	Brass	No	No	700
B 34287	1-1/2	2	1	1-1/4	1/4 NPTF†	1/4 NPTFE	1/4 Flare Access	Plastic	No	No	700
B 35162	1-1/2	2	1	1-1/4	1/8 NPTF†	3/8 ODS	1/4 Flare Access	Steel	No	No	700
B 35334	1-1/2	2	1	1-1/4	1/4 NPTF†	1/4 NPTFE	1/4 Flare Access	Plastic	Yes	Yes	700

* Machined to accept O.D. size tube as indicated.

** Copper gasket included.

† Recognized under the component program of Underwriters Laboratories for use in USA and Canada.

Replacement Caps

A 04566-Steel

A 04597-Brass

P 34627-Plastic

PACKLESS DIAPHRAGM VALVES

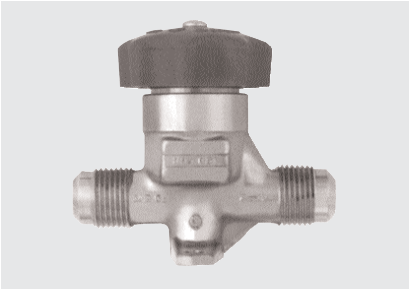

- Longevity: up to 5 times greater than current industry designs.
- Oversized diaphragms provide accurate sealing and extended wear.
- Heat stabilized nylon stem seat for use across a wide temperature range.
- Stem seat is guided in alignment, providing even wear and extended service life.
- Compatible with all new refrigerants and oils.
- Forged brass body with full size openings for maximum flow and minimum pressure drop.
- Integral mounting bracket for ease of installation.
- Available in flare, sweat, angled, and extended tubing configurations.
- All valves are 100% tested and UL/cUL recognized.
- Wide operating temperature range from -40°F to 300°F.
- Working pressure up to 500 psig with flow in direction of arrow on the body; 350 psig with flow against the direction of arrow. Burst pressure at 2500 psig.

STRAIGHT THRU - FLARE TO FLARE - TYPE I - CLASS IV

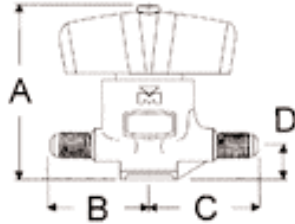

Part No.	Size	A Open	B	C	D	Wt./Ea.
A 14833	1/4	2-11/16	1-5/16	1-3/8	5/8	.75
A 14835	3/8	2-11/16	1-3/8	1-27/64	5/8	.76
A 14836	1/2	3-15/32	1-5/8	1-27/32	27/32	1.25
A 14837	5/8	3-15/32	1-11/16	1-15/16	27/32	1.27

STRAIGHT THRU - SOLDER TO SOLDER - TYPE I - CLASS II

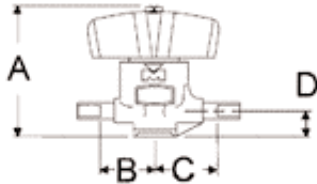

Part No.	Size	A Open	B	C	D	Wt./Ea.
A 14838	1/4	2-11/16	1-1/32	1-3/32	5/8	0.72
A 14840	3/8	2-11/16	1-1/32	1-3/32	5/8	0.71
A 14841	1/2	3-1/2	1-5/16	1-9/16	27/32	1.22
A 14842	5/8	3-1/2	1-13/64	1-7/16	27/32	1.22

EXTENDED END - SOLDER TO SOLDER - TYPE I - CLASS II

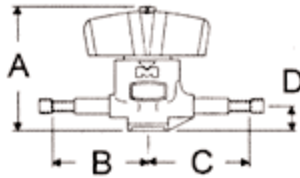

Part No.	Size	A Open	B	C	D	Wt./Ea.
A 14848	1/4	2-11/16	2-21/32	2-23/32	5/8	0.75
A 14850	3/8	2-11/16	2-13/16	2-7/8	5/8	0.76
A 14851	1/2	3-1/2	3-1/32	3-11/32	27/32	1.28
A 14852	5/8	3-1/2	3-7/64	3-11/32	27/32	1.34

ANGLE - NPTFE TO FLARE - TYPE I - CLASS I

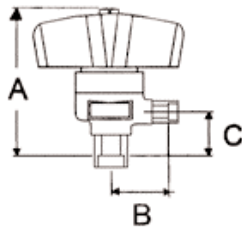

Part No.	Size	O.D.	O.D.	A Open	B	C	Wt./Ea.
A 15525	1/4	1/4	1/4	2-13/16	1-19/64	1-3/64	0.61
A 15526	1/4	3/8	3/8	2-13/16	1-27/64	1-3/64	0.63
A 15527	3/8	3/8	3/8	2-7/8	1-27/64	1-5/64	0.64
A 15528	3/8	3/8	3/8	2-7/8	1-27/64	1-5/64	0.64
A 15529	3/8	1/2	1/2	3-9/16	1-27/32	1-19/64	1.06
A 15530	1/2	1/2	1/2	3-11/16	1-27/32	1-7/16	1.06
A 15531	1/2	5/8	5/8	3-11/16	1-15/16	1-7/16	1.08

ANGLE - SOLDER TO SOLDER - TYPE I - CLASS I

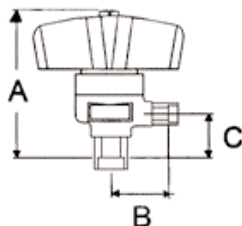

Part No.	Size	O.D.	O.D.	A Open	B	C	Wt./Ea.
A 15539	1/4	1/4	1/4	2 17/32	1 3/32	3/4	0.69
A 15540	3/8	3/8	3/8	2 17/32	1 3/32	3/4	0.71
A 15541	1/2	1/2	1/2	3 5/16	1 3/16	1 1/16	1.14
A 15542	5/8	5/8	5/8	3 13/64	5/16	15/16	1.14



COMPRESSOR VALVES & KITS

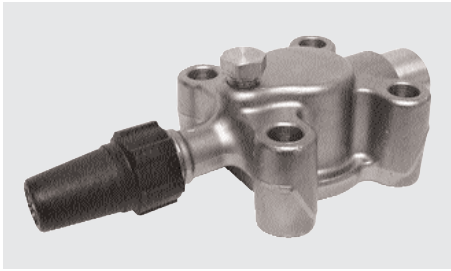

- Valve cross-reference available for all compressor manufacturers.
- Asbestos-Free valve packing material.
- Models available in forged brass and cast iron.
- Complete service kit including valve body, mounting, bolts, cap and gaskets.
- Direct original equipment replacement parts for all industry manufactured compressors.
- Manufactured to the strictest quality standards in the industry.
- Valve openings designed for maximum flow and minimum pressure drop.
- Compatible with all new refrigerant and oils
- 700 psig maximum working pressure, 3500 psig burst pressure
- Wide operating temp range from -40°F to 300°F
- Special flanges and adapters available upon request.
- All valves 100% tested.
- Recognized under component program of Underwriters Laboratories for use in the USA and Canada.

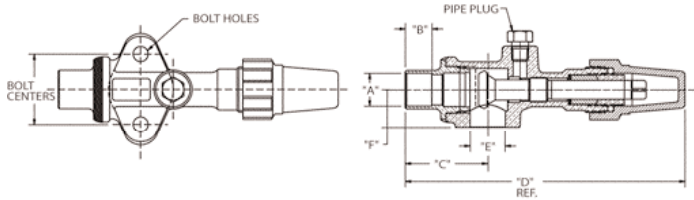

STRAIGHT PORT-SOLDER TYPE-PLASTIC CAP

Valve	Kit	A	B	C	D	E	F	Bolt Centers	Dia Bolt Holes	Pipe Plug Size	Flange Bolt Centers	Flange Thickness	Valve Wt.	Kit Wt.
A 16310	A 17517	3/4	5/8	1-29/32	6-9/16	13/16	7/8	1-5/8	11/32	1/8		1-21/64	1.64	1.69
A 16311	A 17515	7/8	3/4	1-31/32	6-9/16	13/16	7/8	1-5/8	11/32	1/8		1-21/64	1.63	1.67
A 16317	A 17528	7/8	3/4	1-31/32	6-1/2	13/16	7/8	1-5/8	11/32	1/8		1-21/64	1.63	1.68
B 32197	A 17529	7/8	3/4	1-31/32	6-9/16	13/16	7/8	1-3/4	11/32	1/8		1-21/64	1.42	1.69
A 15500		1-1/8	29/32	2-1/16	6-9/16	13/16	7/8	1-5/8	11/32	1/8		1-21/64	1.66	
A 16312	A 17516	1-1/8	29/32	2-1/16	6-9/16	13/16	7/8	1-5/8	11/32	1/8		1-21/64	1.66	1.71
B 33367	A 17530	1-1/8	29/32	2-17/64	6-9/16	1-1/8	7/8	1-3/4	11/32	1/4		1-21/64		

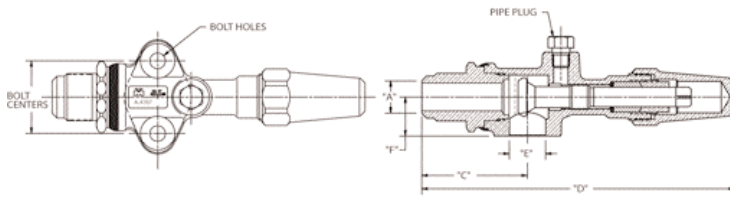

STRAIGHT PORT-45° FLARE TYPE-PLASTIC CAP

Valve	Kit	A	B	C	D	E	F	Bolt Centers	Dia Bolt Holes	Pipe Plug Size	Flange Bolt Centers	Flange Thickness	Valve Wt.	Kit Wt.
A 13166		3/4		2-3/8	7	13/16	7/8	1-5/8	11/32	1/8		1-1/4	1.78	

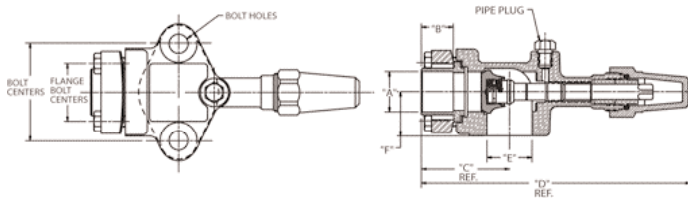

FLANGE UNION-SOLDER TYPE-PLASTIC CAP

Valve	Kit	A	B	C	D	E	F	Bolt Centers	Dia Bolt Holes	Pipe Plug Size	Flange Bolt Centers	Flange Thickness	Valve Wt.	Kit Wt.
A 16313		3/4	5/8	2-5/16	7-11/32	1-1/4	1-1/4	2-3/4	17/32	1/8	1-5/8	1	3.93	
A 16314	A 17527	7/8	3/4	2-5/16	7-11/32	1-1/4	1-1/4	2-3/4	17/32	1/8	1-5/8	1	3.90	4.05
A 16315	A 17525	1-1/8	29/32	2-15/32	7-1/2	1-1/4	1-1/4	2-3/4	17/32	1/8	1-5/8	1	3.88	4.03
A 16316	A 17526	1-3/8	31/32	2-15/32	7-1/2	1-1/4	1-1/4	2-3/4	17/32	1/8	1-5/8	1	3.66	3.80

COMPRESSOR VALVES & KITS

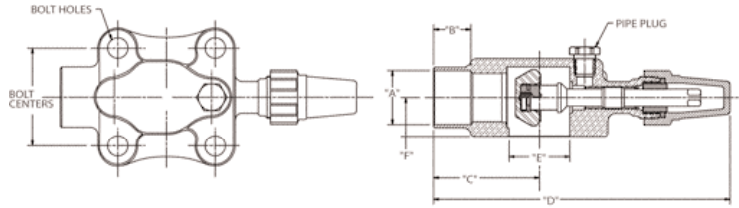

DOUBLE PORT-SOLDER TYPE-STEEL CAP

Valve	Kit	A	B	C	D	E	F	Bolt Centers	Dia Bolt Holes	Pipe Plug Size	Flange Bolt Centers	Flange Thickness	Valve Wt.	Kit Wt.
A 16307	A 17510	3/8	5/16	1-1/4	4-5/64	9/16	5/8	1-5/8	11/32	1/8		7/8	0.69	0.73
A 16308	A 17511	1/2	3/8	1-13/32	4-13/64	9/16	5/8	1-5/8	11/32	1/8		7/8	0.86	0.89
A 16309	A 17512	5/8	1/2	1-1/2	4-1/2	9/16	5/8	1-5/8	11/32	1/8		7/8	0.88	0.92
A 16309	A 17531	5/8	1/2	1-1/2	4-1/2	9/16	5/8	1-5/8	11/32	1/8		7/8	0.88	0.92

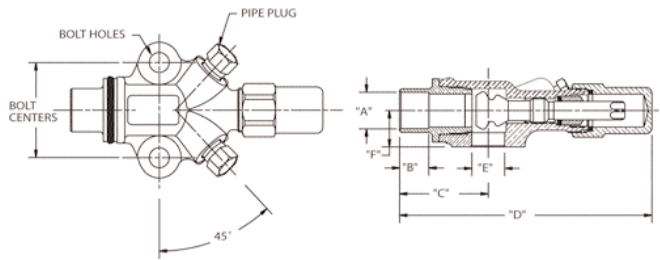

DOUBLE PORT-45° FLARE TYPE-STEEL CAP

Valve	Kit	A	B	C	D	E	F	Bolt Centers	Dia Bolt Holes	Pipe Plug Size	Flange Bolt Centers	Flange Thickness	Valve Wt.	Kit Wt.
A 16302	A 17518	3/8		1-3/4	4-7/16	9/16	5/8	1-5/8	11/32	1/8		7/8	1.20	1.24
A 16303	A 17519	1/2		1-7/8	4-11/16	9/16	5/8	1-5/8	11/32	1/8		7/8	1.17	1.20
A 16304	A 17520	5/8		2	4-13/16	9/16	5/8	1-5/8	11/32	1/8		7/8	1.23	1.27

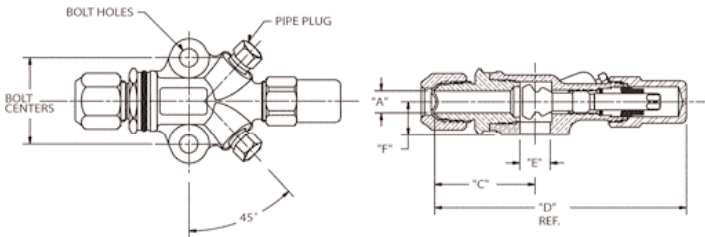

4-BOLT MOUNTING STYLE-SOLDER TYPE-FLAT GASKET SURFACE-PLASTIC CAP

Valve	Kit	A	B	C	D	E	F	Bolt Centers	Dia Bolt Holes	Pipe Plug Size	Flange Bolt Centers	Flange Thickness	Valve Wt.	Kit Wt.
B 32087	A 17532	1-1/8	29/32	2-23/32	7-5/8	1-9/16	1	2-1/2	17/32	1/4			3.88	4.03
B 32088	A 17533	1-3/8	31/32	2-23/32	7-5/8	1-9/16	1	2-1/2	17/32	1/4			3.66	3.80
B 32930	A 17534	1-5/8	1-3/32	2-7/8	7-5/8	1-9/16	1-1/32	2-1/2	17/32	1/4			3.90	4.05

TUBE & PIPE

METAL FITTINGS
& NIPPLES

PLASTIC
FITTINGS

VALVES

FILTER-DRIERS
& STRAINERS



COMPRESSOR VALVES & KITS

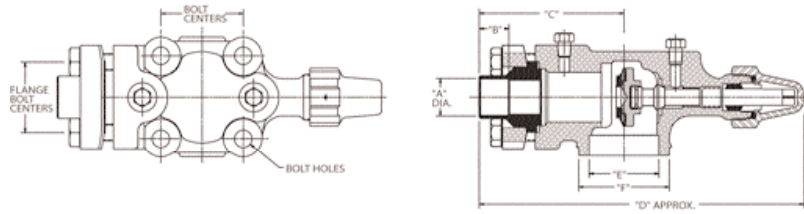

4-BOLT-CAST IRON COMPRESSOR VALVES

Valve	Kit	A	B	C	D	E	F	Bolt Centers	Dia Bolt Holes	Pipe Plug Size	Flange Bolt Centers	Seal Cap Material	Valve Wt.	Kit Wt.
B 33813		1-3/8	31/32	4-13/32	9-29/32	2-1/8	2-3/4	2-1/2	17/32	1/4	2-1/8	Cast Iron	9.43	
A 15246		1-5/8	1-3/32	3-61/64	9-15/32	2-1/8	2-3/4	2-1/2	17/32	1/4	2-1/8	Valox	9.37	
A 16321	A 17513	1-5/8	1-3/32	4-19/32	10 -3/64	2-1/8	2-3/4	2-1/2	17/32	1/4	2-1/8	Valox	8.72	8.92
A 16367	A 17524	1-5/8	1-3/32	5-1/4	11-29/32	2-17/32	3-7/32	3-1/16	11/16	1/4	3-1/16	Valox	18.20	18.61
A 16496		1-5/8	1-3/32	3-61/64	9-15/32	2-1/8	2-3/4	2-1/2	17/32	1/4	2-1/8	Valox	8.74	
B 32337		1-5/8	1-3/32	3-61/64	9-15/32	2-1/8	2-3/4	2-1/2	17/32	1/4	2-1/8	Valox	9.07	
B 33770		1-5/8	1-3/32	4-19/32	10-1/64	2-1/8	2-3/4	2-1/2	17/32	1/4	2-1/8	Cast Iron	8.46	
B 33842		1-5/8	1-3/32	5-1/4	11-29/32	2-17/32	3-7/32	3-1/16	11/16	1/4	3-1/16	Cast Iron	18.97	
B 33784		2	1-9/32	5-1/64	11-55/64	2-17/32	3-7/32	3-1/16	11/16	1/4	3-1/16	Valox	16.42	
A 15586	A 17535	2-1/8	1-5/16	5-1/16	11-61/64	2-17/32	3-7/32	3-1/16	11/16	1/4	3-1/16	Valox	18.28	6.69
A 16324	A 17523	2-1/8	1-5/16	5-1/16	11-61/64	2-17/32	3-7/32	3-1/16	11/16	1/4	3-1/16	Valox	18.28	18.69
A 16493		2-1/8	1-5/16	5-1/16	11-61/64	2-17/32	3-7/32	3-1/16	11/16	1/4	3-1/16	Valox	17.71	
B 33572		2-1/8	1-5/16	5-1/16	11-61/64	2-17/32	3-7/32	3-1/16	11/16	1/4	3-1/16	Valox	17.49	
B 33771	B 34325	2-1/8	1-5/16	5-1/16	11-7/8	2-17/32	3-7/32	3-1/16	11/16	1/4	3-1/16	Cast Iron	16.05	19.54
B 34429		2-1/8	1-5/16	5-1/16	11-61/64	2-17/32	3-7/32	3-1/16	11/16	1/4	3-1/16	Valox	17.28	
B 34671		2-1/8	1-5/16	5-1/16	11-61/64	2-33/64	3-7/32	3-1/16	11/16	1/4	3-1/16	Valox	17.28	
A 15587		2-5/8	1-9/32	5-1/64	12-11/16	2-17/32	3-7/32	3-1/16	11/16	1/4	3-1/16	Valox	20.30	
A 16366	A 17522	2-5/8	1-15/32	6-1/2	15-1/8	3-11/32	4-5/32	3-7/8	11/16	1/4	3-7/8	Cast Iron	33.18	33.73
B 33568		2-5/8	1-9/32	5-1/64	11-29/32	2-17/32	3-7/32	3-1/16	11/16	1/4	3-1/16	Valox	20.23	
B 34314		2-5/8	1-15/32	6-1/2	15-1/8	3-11/32	4-5/32	3-7/8	11/16	1/4	3-7/8	Cast Iron	30.80	
B 34582		2-5/8	1-17/64	5-3/64	11-29/32	2-17/32	3-7/32	3-1/16	11/16	1/4	3-1/16	Valox		
B 34661		2-5/8	1-15/32	6-1/2	15-1/8	3-11/32	4-5/32	3-7/8	11/16	1/4	3-7/8	Cast Iron	30.80	
A 15588		3-1/8	1-7/32	5-15/16	14-39/64	3-11/32	4-5/32	3-7/8	11/16	1/4	3-7/8	Cast Iron	33.22	
A 16365	A 17521	3-1/8	1-7/32	5-15/16	14-39/64	3-11/32	4-5/32	3-7/8	11/16	1/4	3-7/8	Cast Iron	33.22	33.77
B 33569		3-1/8	1-7/32	5-15/16	14-39/64	3-11/32	4-5/32	3-7/8	11/16	1/4	3-7/8	Cast Iron	32.38	
A 17496		3-5/8	2-1/16	7	16-19/64	3-7/8	4-35/64	4-1/4	11/16	1/4	4-1/4	Cast Iron	34.01	
B 33788		3-5/8	2-1/16	7	16-19/64	3-7/8	4-35/64	4-1/4	11/16	1/4	4-1/4	Cast Iron	34.01	
B 34315		3-5/8	2-1/16	7	16-19/64	3-7/8	4-35/64	4-1/4	11/16	1/4	4-1/4	Cast Iron	40.51	
B 34670		3-5/8	2-1/16	7	16-19/64	3-7/8	4-9/64	4-1/4	11/16	1/4	4-1/4	Cast Iron	40.51	
A 15589		4-1/8	1-31/32	7-7/32	17-1/2	4-3/8	5-1/8	4-13/16	13/16	1/4	4-13/16	Cast Iron	49.80	

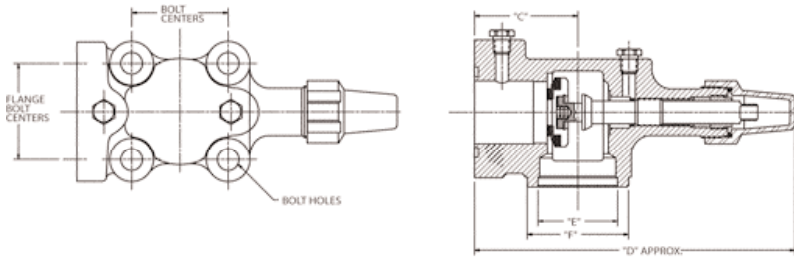

4-BOLT-CAST IRON COMPRESSOR VALVES WITHOUT FLANGES

Valve	Kit	A	B	C	D	E	F	Bolt Centers	Dia Bolt Holes	Pipe Plug Size	Flange Bolt Centers	Seal Cap Material	Valve Wt.	Kit Wt.
B 33793				3-9/32	10-11/64	2-17/32	3-7/32	3-1/16	11/16	1/4	3-1/16	Valox	12.58	
B 33794				3-25/32	12-7/16	3-11/32	4-5/32	3-7/8	11/16	1/4	3-7/8	Cast Iron	22.05	
B 34183				2-11/16	8-3/32	2-1/8	2-3/4	2-1/2	17/32	1/4	2-1/8	Valox	6.91	
B 34497				3-63/64	13-1/4	3-7/8	4-35/64	4-1/4	11/16	1/4	4-1/4	Cast Iron	34.00	
B 34498				3-9/32	10-1/8	2-17/32	3-7/32	3-1/16	11/16	1/4	3-1/16	Valox	17.28	
B 34715				3-25/32	13	3-11/32	4-5/32	3-7/8	11/16	1/4	3-7/8	Steel	22.05	
B 34761				3-9/32	10-11/64	2-17/32	3-1/32	3-1/16	11/16	1/4	3-1/16	Valox	13.00	
B 34929**				4-9/16	14-53/64	4-3/8	5-1/8	4-13/16	13/16	1/4	4-13/16	Cast Iron	37.00	
B 35049				3-9/32	10-1/8	2-17/32	3-7/32	3-1/16	11/16	1/4	3-1/16	Valox	12.97	

COMPRESSOR VALVES & KITS

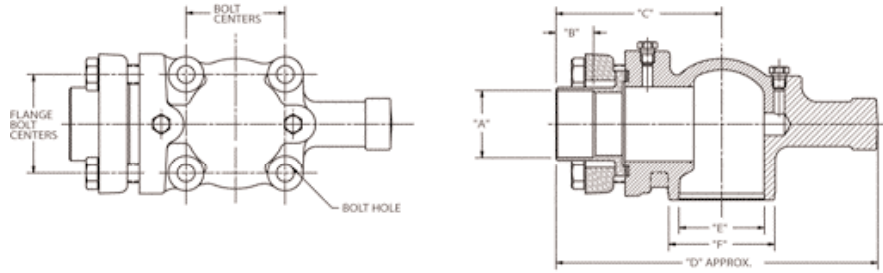

4-BOLT-CAST IRON FLANGES

Valve	Kit	A	B	C	D	E	F	Bolt Centers	Dia Bolt Holes	Pipe Plug Size	Flange Bolt Centers	Seal Cap Material	Valve Wt.	Kit Wt.
B 34987*		2-5/8	1-15/32	6-1/2	12-35/64	3-11/32	4-5/32	3-7/8	1 1/16	1/4	3 7/8		28.50	
B 33794		3-5/8	2-1/16	7	13-39/64	3-7/8	4-9/16	4-1/4	1 1/16	1/4	4 1/4		33.50	

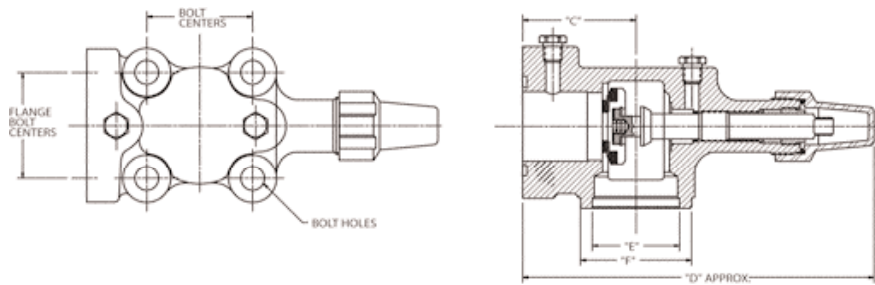

AMMONIA VALVES

Valve	Kit	A	B	C	D	E	F	Bolt Centers	Dia Bolt Holes	Pipe Plug Size	Flange Bolt Centers	Seal Cap Material	Valve Wt.	Kit Wt.
B 35308				3-9/32	10-11/64	2-17/32	3-7/32	3-1/16	1 1/16		3-1/16	Valox	13.02	
B 35358				3-25/32	12-7/16	3-11/32	4-5/32	3-7/8	1 1/16		3-1/16	Cast Iron	22.05	

TUBE & PIPE

METAL FITTINGS & NIPPLES

PLASTIC FITTINGS

VALVES

FILTER-DRIERS & STRAINERS



CHECK VALVES



- Recognized under component program of Underwriters Laboratories for use in the USA and Canada
- Maximum working pressure is 500 psig.
- maximum temperature rating at +200°F
- Soft Neoprene seat provides positive seal against reverse flow.
- Four spacer tabs maintain washer/seat alignment and guide the seat disc for smooth operation.
- Stainless steel spring allows valve to operate (close) in any position.
- Buna N Gasket provides permanent seal.
- Brass body machined from drawn brass rod is designed to offer minimum restriction to flow.

FLARE TO FLARE

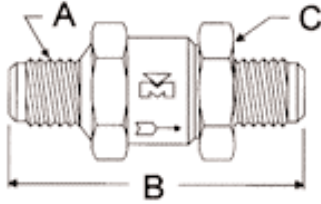

Part No.	Size Flare			Wt./Ea.
	A	B	C	
A 15620	1/4	2-3/16	13/16 Hex	.14
A 15621	3/8	2-13/32	13/16 Hex	.18
A 15622	1/2	3	1-1/4 Oct	.44
A 15623	5/8	3-5/16	1-1/4 Oct	.52

SOLDER TO SOLDER-SHIPED LOOSELY ASSEMBLED

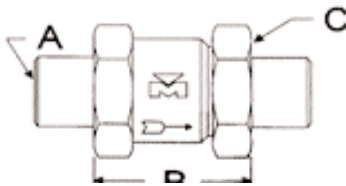

Part No.	Size O.D.			Wt./Ea.
	A	B	C	
A 15628	1/4	1-3/16	13/16 Hex	.13
A 15629	3/8	1-5/32	13/16 Hex	.13
A 15630	1/2	1-7/16	1-1/4 Oct	.36
A 15631	5/8	1-7/16	1-1/4 Oct	.37

SOLDER TO SOLDER-EXTENDED ENDS

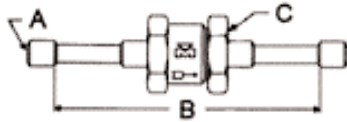

Part No.	Size O.D.			Wt./Ea.
	A	B	C	
A 15632	1/4	4-7/16	13/16 Hex	.17
A 15633	3/8	4-9/16	13/16 Hex	.17
A 15634	1/2	4-29/32	1-1/4 Oct	.42
A 15635	5/8	5-13/64	1-1/4 Oct	.48

FOUR-BOLT CHECK VALVES

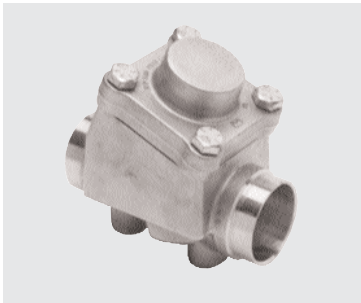

- 4-bolt flange allows easy disassembly and assembly for brazing or internal component changes.
- Forged brass body ensures the product exceeds the most stringent quality standards in the industry.
- Horizontal or vertical installation.
- "Y" type design provides minimal pressure drop and increased flow capacity.
- Non-asbestos gasket material and O-Ring seal ensures seal integrity and is compatible with new refrigerants and oils.
- Heat-stabilized P.F.T.E seat provides positive seal across wide temperature ranges.
- Working temperature range from -40°F to 300°F, and maximum working pressure 500 psig.
- Back-pressure shutoff at low pressure differentials.
- Special springs available for various differential applications.
- All valves 100% tested and compatible with all fluorinated refrigerants.
- Recognized under the component program of Underwriters Laboratories for use in the USA and Canada.

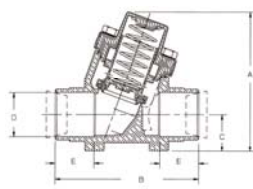

Size	Part No.	A	B	C	D	E	Cv	Weight	Replacement		Replacement Components	
									Kit No.**	10 lb Spring	Alternative Spring	Gasket
7/8	B 34235	3-19/32	3-11/16	3-1/32	7/8	15/16	5.05	2.46	A 17986	P 35656	P 35859, 30 lb	P 35708
1-1/8	B 34236	3-19/32	3-11/16	3-1/32	1-1/8	1	6.7	2.31	A 17986	P 35657	*	P 35708
1-3/8	B 34237	4-9/16	4-3/4	1-5/16	1-3/8	1-1/16	8.71	5.42	A 17987	P 35657	P 36305, 20 lb	P 35691
1-5/8	B 34238	4-9/16	4-3/4	1-5/16	1-5/8	1-1/16	10.06	5.04	A 17987	P 35657	*	P 35691
2-1/8	B 34239	5-7/8	6-3/8	1-11/16	2-1/8	1-1/2	36	12.6	A 17988	P 36544	*	P 35721
2-5/8	B 34240	8	8-7/8	2	2-5/8	1-7/8	70	*	A 18050	*	*	P 36041
3-1/8	B 34241	8	8-7/8	2	3-1/8	1-7/8	*	*	A 18050	*	*	P 36041

* Consult factory

** Replacement kit includes seat holder subassembly, cover gasket and 2 lb. spring

CMV SERIES MAGNETIC CHECK VALVES

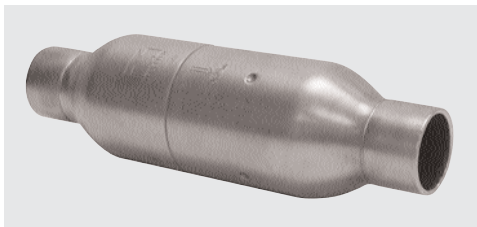

- Near zero leak rate.
- Built-in 30 mesh stainless steel screen.
- Internal components installed with DuraForm Technology.
- Mechanically formed solder cup stops for ease of installation.
- Flexible for installation in a vertical or horizontal position.
- Compatible with all CFC, HCFC and HFC refrigerants.
- All valves are UL/cUL/CE recognized.
- Wide operating temp range from -400°F to 300° F

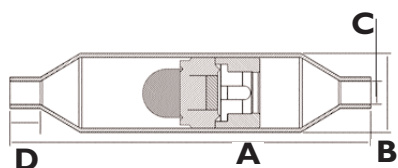

Part Number	CMV Series	Connection Size (in)	A (in)	B (in)	D Min (in)	MWP (psi)	Cross Reference
							Leakage Rate (in3/min)
A 17934	CMV-4S	1/4"	4	7/8	.31	800	0.15
A 17935	CMV-6S	3/8"	4	7/8	.31	800	0.15
A 17936	CMV-8S	1/2"	5-1/8	1-1/8	.38	700	.034
A 17937	CMV-10S	5/8"	5-1/8	1-1/8	.50	700	.034
A 17938	CMV-12S	3/4"	7	1-5/8	.62	700	.074
A 17939	CMV-14S	7/8"	7	1-5/8	.75	700	.074
A 17940	CMV-18S	1-1/8"	8-3/8	2-1/8	.91	700	.122
A 17941	CMV-22S	1-3/8"	9-3/8	2-5/8	.97	700	.172
A 17942	CMV-26S	1-5/8"	10-1/2	3-1/8	1.09	700	.272
A 17943	CMV-34S	2-1/8"	12	3-5/8	1.34	700	.386
A 17944	CMV-42S	2-5/8"	13	4-1/8	1.47	700	.512
A 17981	CMV-50S	3-1/8"	13	4-1/8	1.66	650	.512

HI-FLOW RESIDENTIAL CHECK VALVES

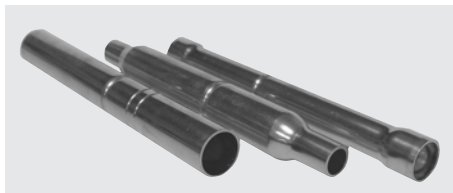

- Design implements a piston stopper, providing a more positive seal, reducing the leak rate compared to industry standards
- Internal components constructed of brass and stainless steel.
- Wide operating temperature range of -40°F to 300°F, and working pressures up to 700 psig.
- Flexible design allows specialty connection combinations, assembly lengths and filtration mesh sizes.
- Compatible with all CFC, HCFC and HFC refrigerants and oils.
- Slotted Cage versions available for greater flow capacity.

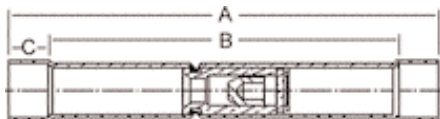

3/8" BODY WITH SOLID CAGE				
Part Number	Connection Type	A	B	C
A 17992	1/4" F x 1/4" F	3.96	3.34	.31
A 17993	3/8" M x 1/8" M	3.96	3.34	.31
A 17994	3/8" M x 3/8" F	3.96	3.34	.31

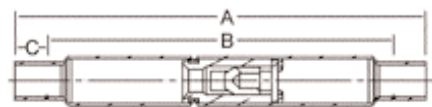

1/2" BODY WITH SLOTTED CAGE				
Part Number	Connection Type	A	B	C
A 17995	1/4" F x 1/4" F	4.00	3.38	.31
A 17996	3/8" F x 1/8" F	4.00	3.38	.31
A 17997	1/2" F x 1/2" F	4.00	-	-
A 17998	1/2" F x 1/2" F	4.00	3.24	.38
A 17999	1/2" F x 1/2" M	4.65	4.27	.38

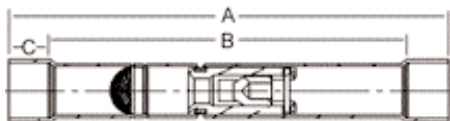

1/2" BODY WITH SLOTTED CAGE AND SCREEN				
Part Number	Connection Type	A	B	C
A 18006	1/4" F x 1/4" F	4.00	3.38	.31
A 18007	3/8" F x 1/8" F	4.00	3.38	.31
A 18008	1/2" M x 1/2" M	4.00	-	-
A 18009	1/2" F x 1/2" F	4.00	3.21	.38
A 18010	1/2" F x 1/2" M	4.65	4.27	.38



SCREW BONNET CHECK VALVES



- Design features easy removal and reassembly of internal components.
- Designed to provide minimal pressure drop and increased flow capacity.
- Bonnet gasket is made from neoprene o-ring, offering a reusable seal.
- Special seal technology provides positive shut off with low back pressure.
- Maximum working pressure is 700 psig.
- Lightweight spring requires minimum opening force.
- Available with copper tube extensions.
- Compatible with all CFC, HCFC and HFC refrigerants.
- Recognized under the component program of Underwriters Laboratories for use in the USA and Canada.
- Working temperature range from -40°F to 300°F

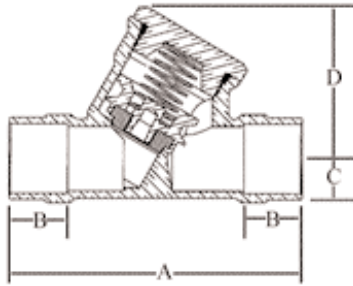

Part No.	Size	A	B	C	D	Cv	Replacement Springs	
							5 lbs.	10 lbs.
ODS X ODS								
A 17953	1/4	3	5/16	7/16	1-5/8	*	P 36542	P 36543
A 17954	3/8	3	7/16	7/16	1-5/8	*	P 36542	P 36543
A 17955	1/2	3	9/16	7/16	1-5/8	*	P 36542	P 36543
A 17956	5/8	3-5/16	11/16	7/16	1-5/8	*	P 36542	P 36543
A 17957	3/4	3-3/4	3/4	5/8	2	*	*	*
A 17958	7/8	3-3/4	3/4	5/8	2	*	*	*
B 34873	5/8	3-3/4	3/4	5/8	2	*	*	*
Extended Ends								
AT17953	1/4	6-1/4	5/16	7/16	1-5/8	*	P 36542	P 36543
AT17954	3/8	6-1/8	3/8	7/16	1-5/8	*	P 36542	P 36543
AT17955	1/2	5-15/16	3/8	7/16	1-5/8	*	P 36542	P 36543
AT17956	5/8	6-13/16	1/2	7/16	1-5/8	*	P 36542	P 36543
AT17958	7/8	7-3/4	3/4	5/8	2	*	*	*

* Contact Factory

Prefixed for Spring Options:

AG = Includes 5 lb. spring

AH = Includes 10 lb. spring

Examples:

A 17953 = 1/4 ODS x ODS w/ 2 lb. spring

AG 17953 = 1/4 ODS x ODS w/ 5 lb. spring

ATG 17953 = 1/4 ODS x ODS extended ends w/ 5 lb. spring

RUPTURE DISC



- One piece brass construction.
- Non-fragmenting Rupture Disc.
- Dual Access Ports.
- Certified to meet ASME Code.
- Certified Category 4 product for CE (PED) Requirements.
- Pressure gauge accessory available.

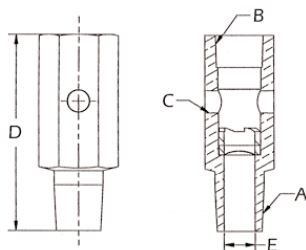

ASME/CE Valve	A NPT	B NPT	C NPT	D		Pressure Gauge Part No.
				(in)	(cm)	
A 17971	1/2	1/2	1/8	2.81	7.14	1.2736214

Prefixes for standard settings are:

AD = 235 psig

AG = 350 psig

AI = 425 psig

AE = 300 psig

AH = 400 psig

AJ = 450 psig

PRESSURE RELIEF VALVES

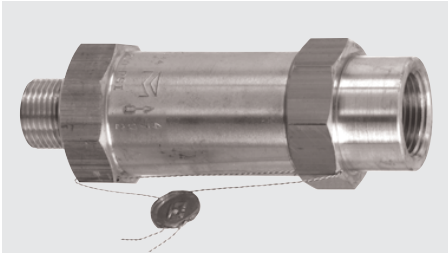

- Designed and engineered to provide high volume discharge.
- Designed to operate according to ASHRAE standard 15.
- Comply with ASME code for unfired pressure vessels.
- Discharge rates are certified by the National Board of Boiler and Pressure Vessel Inspectors.
- Quality components include brass body, "P.F.T.E clad" neoprene seat, stainless steel spring and copper gasket.
- Anti-tamper seal and locking wire

STRAIGHT THRU-NPTFE INLET TO FLARE

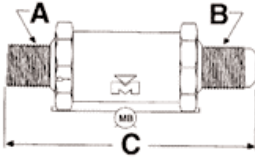

ASME Valve	Inlet (A) (in)	Outlet (B) (in)	(C)		Wt. Ea.		Discharge Table
			(in)	(cm)	(lb)	(kg)	
A 15501	1/4	3/8	2-21/32	6.75	0.19	0.09	A
A 15502	3/8	3/8	2-13/16	7.14	0.33	0.15	B
A 15503	3/8	1/2	3	7.62	0.36	0.16	B
A 15504	1/2	5/8	4-3/16	10.64	0.84	0.38	C
B 33752	1/4	3/8	2-13/16	7.14	0.32	0.14	B
B 33753	1/4	1/2	3	7.62	NA	NA	B

ANGLE-NPTFE TO FLARE

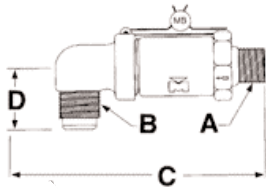

ASME Valve	Inlet (A) (in)	Outlet (B) (in)	(C)		(D)		Wt. Ea.		Discharge Table
			(in)	(cm)	(in)	(cm)	(lb)	(kg)	
B 33746	1/4	3/8	2-3/8	6.03	1-1/8	2.86	0.30	0.14	B
B 33754	1/4	1/2	2-7/16	6.19	1-5/16	3.33	NA	NA	B
A 15512	3/8	3/8	2-3/8	6.03	1-3/8	3.49	0.36	0.16	B
A 15513	3/8	1/2	2-3/8	6.03	1-11/32	3.41	0.38	0.17	B
A 15514	1/2	5/8	4-3/32	10.40	1-9/16	3.97	0.98	0.45	C

ATMOSPHERIC-NPTFE INLET

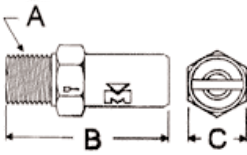

ASME Valve	Inlet (A) (in)	(B) (in)	(C)		Wt. Ea.		Discharge Table
			(in)	(cm)	(lb)	(kg)	
A 15508	1/8	1-7/8	3/4	1.91	0.12	0.05	A
A 15509	1/4	2	3/4	1.91	0.13	0.06	A
A 17430	3/8	2-1/8	1	2.54	0.24	0.11	B
B 33755	1/4	2-1/8	1	2.54	NA	NA	B

STRAIGHT THRU-NPTFE INLET TO NPTFI OUTLET

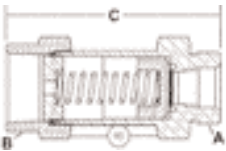

ASME Valve	Inlet (A) (in)	(B) (in)	(C)		Wt. Ea.		Discharge Table
			(in)	(cm)	(lb)	(kg)	
A 17840	1	1	4-9/16	11.59	1.95	0.88	E
A 17834	1-1/4	1-1/4	5	12.70	2.00	0.91	F
A 15506	3/4	3/4	5	12.70	1.49	0.68	D

STRAIGHT THRU-STRAIGHT THREAD INLET TO NPTFI OUTLET

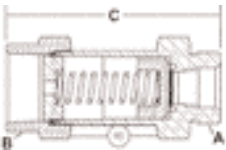

ASME Valve	Inlet (A) (in)	(B) (in)	(C)		Wt. Ea.		Discharge Table
			(in)	(cm)	(lb)	(kg)	
B 34444	7/8 -14 UNF 2A	3/4	5	12.70	1.53	0.69	D
B 34519	1-5/16 -12UNF2A	1	4 3/8	11.11	1.37	0.62	E
B 34580	1-5/8 -12UNF-2A	1-1/4	5	12.70	2.00	0.91	F

Prefixes for standard settings are:

AD/BD = 235 psig. AH/BH = 400 psig.
 AE/BE = 300 psig. AI/BI = 425 psig.
 AG/BG = 350 psig. AJ/BJ = 450 psig.

For valves furnished at non-standard settings, use part numbers as listed in specification charts and indicate exact pressure setting.

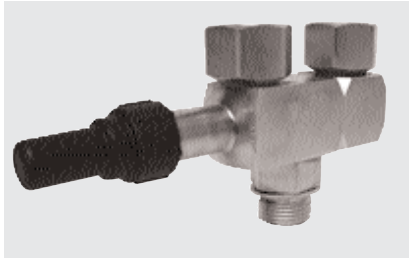
RELIEFMASTER™ CHANGE-OVER MANIFOLD

- Optimized body chamber provides maximum flow to assure high relief discharge capacities.
- Internal metal to metal seat with no seals or bearings to assure compatibility with all new refrigerants and oils.
- Custom connections available including rotolock, flare, solder, and O-Ring seal.
- Efficient space-saving low profile design.
- Meets ASHRAE 15, ASME Codes, National Board certified.
- Recognized under the component program of Underwriters Laboratories for use in the USA and Canada.
- Operating temperature range from -40°F to 300°F.
- Maximum working pressure of 500 psig; burst pressure of 2500 psig.

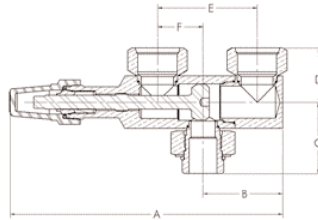

Part No.	Inlet	Outlets	A (in.)	B (in.)	C (in.)	D (in.)	E (in.)	F (in.)
A 17921	1/2 NPTFE	1/2 NPTFI	6	1-3/4	1-3/4	1-3/8	2-1/16	3/4
A 17922	3/4 NPTFE	3/4 NPTFI	6	1-3/4	1-7/8	1-3/8	2-1/16	3/4
A 17923	1 NPTFE	1 NPTFI	8-11/16	2-7/16	2-3/8	1-7/8	3-1/8	1-7/16
A 17924	1 1/4 NPTFE	1 1/4 NPTFI	8-7/8	2-7/16	2-7/16	2-1/8	3-1/8	1-7/16
B 34550	7/8 -14 UNF 2A	7/8 -14 UNF 2B	6	1-3/4	1-5/8	1-3/8	2-1/16	3/4
B 34559	1 5/16 -12 UNF 2A	1 5/16 -12 UNF 2B	8-9/16	2-7/16	2-1/8	1-3/4	3-1/8	1-7/16
B 34654	1 5/8 -12 UNF 2A	1 5/8 -12 UNF 2B	8-9/16	2-7/16	2-1/8	1-13/16	3-1/8	1-7/16
B 35272	1 NPTFI	1 NPTFI	11-13/32	5-13/32	1-15/16	1-31/32	1-7/8	1-7/16
B 35273	1 1/4 NPTFI	1 1/4 NPTFI	11-13/32	5-13/32	1-15/16	1-31/32	1-7/8	1-7/16
B 35271	3/4 NPTFI	3/4 NPTFI	7-23/32	3-17/32	1-11/16	1-11/16	3-5/8	3/4

MUELLER ANGLE ISOLATION VALVES

- Optimized body chamber provides maximum flow characteristics
- Design incorporates a fully backseated stem and seat for minimal valve pressure drop.
- Brass construction eliminates corrosion.
- Internal metal to metal seat provides exceptional durability and positive isolation.
- "Quick-Change" packing gland allows easy replacement without refrigerant loss.
- Rotolock or sweat configurations customized to specific applications.
- Asbestos-free packing material.
- Wide operating temperature range of -40°F to 300°F and working pressures up to 500 psig.
- Recognized under the component program of Underwriters Laboratories for use in the USA and Canada.
- Compatible with all new refrigerants and oils.

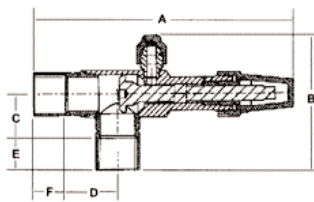
**SOLDER X SOLDER ANGLE ISOLATION VALVE**

Part No.	Size	Cv	A	B	C	D	E	F	Flare Size
B 34413	5/8 ODS x 5/8 ODS	6	5-27/64	2-21/32	27/32	1-11/64	1/2	1/2	1/4
B 34412	7/8 ODS x 7/8 ODS	15	6-9/16	3-3/32	29/32	1-17/64	3/4	3/4	1/4
B 35224	1-1/8 ODS x 1-1/8 ODS	25	7-19/32	3-63/64	1 5/16	1-1/2	15/16	15/16	3/8
B 34479	1-1/8 ODS x 1-3/8 ODS	-	7-19/32	3-3/4	1-1/4	1-1/2	1	15/16	1/4
B 34594	1-3/8 ODS x 1-3/8 ODS	38	9-31/64	4-3/16	1-1/2	1-29/32	1	1	3/8
B 34595	1-5/8 ODS x 1-5/8 ODS	53	10-3/64	4-11/16	1-3/4	2-3/16	1-3/32	1-3/32	1/4

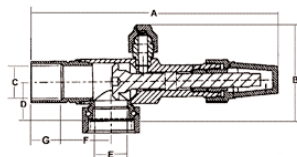
**SOLDER X ROTOLOCK ANGLE ISOLATION VALVE**

Part No.	Size	Cv	A	B	C	D	E	F	G	Flare Size
B 34418	5/8 ODS x 1 THD	6	5-27/64	2-1/4	35/64	15/16	35/64	11/64	1/2	1/4
B 34417	7/8 ODS x 1-1/4 THD	15	6-9/16	2-31/64	3/4	1 3/64	3/4	1 17/64	3/4	1/4
B 34416	1-1/8 ODS x 1-1/2 THD	25	7-19/32	3	1	1 1/4	1	1 35/64	15/16	3/8
B 34415	1-3/8 ODS x 1-3/4 THD	38	9-33/64	3-17/64	1-1/4	1-13/32	1-1/4	1-29/32	1	3/8
B 34414	1-5/8 ODS x 2-1/4 THD	53	10-3/64	3-35/64	1-1/2	1-9/16	1-1/2	2-3/16	1-3/32	3/8

Plumbing Valves (WOG)



Mueller's Plumbing Valves are made to the highest quality and testing standards available. We offer a large selection of valves for a variety of residential, commercial and industrial applications. Our customers can choose from full port, forged brass ball valves to low pressure, low lead, hose-end valves. We also offer a broad range of gate, stop & waste, gas and specialty valves. All bronze/brass bodied valves have the Mueller brand cast on the valve body, a sign of assured quality and service.

- Most valves meet NSF 61-8 OR 61-9 low lead requirements
- Select valves are certified to CSA, UL, FM, ASSE and IAPMO standards



TUBE & PIPE

METAL FITTINGS & NIPPLES

PLASTIC FITTINGS

VALVES

FILTER-DRIERS & STRAINERS

BALL VALVE • FULL PORT • 600 PSI

FORGED BRASS



- 107-403/408HC are 400 PSI Non-Shock WOG
- 107-453/458HC are 600 PSI Non-Shock WOG
- 150 PSI WSP Steam
- Meets NSF approved low lead standards
- CSA Certified – Canadian Standards Association
- -20° to 300° F temperature range
- Dacromet handle
- Hollow ball
- Threaded ends comply with ANSI B1.20.1
- Solder ends comply with ANSI B16.18
- Available in Handy Carton (HC) bin box packaging only

Part No.	UPC-A (032888)	Valve Size	Port Size	CV Rating	Inner/Master Carton Qty.	Master Weight (lbs.)
Threaded						
107-403HC	074033	1/2"	.571	14	20/NA	8
107-404HC	074040	3/4"	.748	27	15/NA	10
107-405HC	074057	1"	.945	39	10/NA	10
107-406HC	074064	1-1/4"	1.240	70	5/NA	7
107-407HC	074071	1-1/2"	1.496	100	5/NA	12
107-408HC	074088	2"	1.850	198	4/NA	14
Solder						
107-453HC	074538	1/2"	.571	14	20/NA	8
107-454HC	074545	3/4"	.748	27	15/NA	10
107-455HC	074552	1"	.945	39	10/NA	10
107-456HC	074569	1-1/4"	1.240	70	5/NA	7
107-457HC	074576	1-1/2"	1.496	100	5/NA	12
107-458HC	074583	2"	1.850	198	4/NA	15

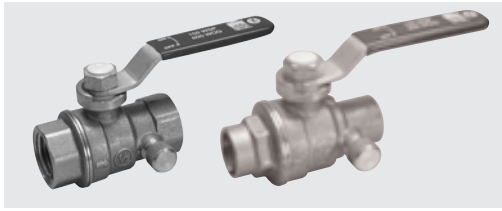

BALL VALVE • STOP & WASTE • 500 PSI**FORGED BRASS**

- 500 PSI water, oil or air
- Meets NSF approved low lead standards
- -20° to 350° F temperature range
- Suitable for vacuum use up to 7 PSI
- Hollow ball
- Drain port allows draining of the non-pressure side of the valve when closed
- Available in Handy Carton (HC) bin box packaging

Part No.	UPC-A (032888)	Valve Size	Port Size	CV Rating	Inner/Master Carton Qty.	Master Weight (lbs.)
Threaded						
107-753	077539	1/2"	.590"	14.2	10/100	42
107-754	077546	3/4"	.787"	28.6	10/60	32
107-755	077553	1"	.984"	56.4	6/36	37
107-753HC	077539	1/2"	.590"	14.2	12/NA	5
107-754HC	077546	3/4"	.787"	28.6	12/NA	8
107-755HC	077553	1"	.984"	56.4	15/NA	15

Solder

107-553	075535	1/2"	.590"	14.2	10/100	40
107-554	075542	3/4"	.787"	28.6	10/60	40
107-555	075559	1"	.984"	56.4	6/36	34
107-553HC	075535	1/2"	.590"	14.2	12/NA	5
107-554HC	075542	3/4"	.787"	28.6	12/NA	8

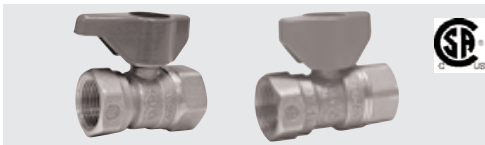
GAS BALL VALVE • TWO PIECE BODY**FORGED BRASS**

- Quarter-turn operation
- May be used with water 400 WOG
- Operating temperatures -40° to 149° F
- CSA 3-88 (5 PSIG) certified
- CSA Tamper proof (T)
- CSA Certified – Canadian Standards Association
- For use with normal, manufactured, mixed, liquefied petroleum and LP gas-air mixtures
- Threaded ends comply with ANSI B1.20.1
- Available in Handy Carton (HC) bin box packaging

Part No.	UPC-A (032888)	Valve Size	Inner/Master Carton Qty.	Master Weight (lbs.)
Lever Handle				
110-122	101227	3/8"	10/100	30
110-125	101258	1"	6/36	23
110-123HC	101234	1/2"	20/NA	7
110-124HC	101241	3/4"	10/NA	6

Tee Handle

111-123HC	111231	1/2"	25/NA	13
111-124HC	111240	3/4"	25/NA	15



- Quarter turn operation
- CSA-3-88 (5 PSIG) certified
- CSA Certified-Canadian Standards Association
- Chrome plated forged brass ball
- May be used with water 200 WOG
- Threaded ends comply with ANSI B1.20.1
- For use with normal, manufactured, mixed, liquefied petroleum and LP gas-air mixtures
- Made in China

Lever Handle

110-223HC	102231	1/2"	1/20	10
110-224HC	102248	3/4"	1/30	10

Lever Handle

110-223C		1/2"	10/100	33
110-224C		3/4"	10/100	48

GAS BALL VALVE • ONE PIECE BODY

FORGED BRASS



- Quarter turn operation
- CSA- 3-88 (5 PSIG) Certified
- CSA Tamper proof (T)
- CSA Certified – Canadian Standards Association
- UL -Water (258)
- One piece body (3/8" - 3/4")
- Chrome plated forged brass ball
- Coated aluminum handle (3/8" - 3/4")
- Dacromet steel plated handle (1" - 2")
- Threaded ends comply with ANSI B1.20.1
- Available in Handy Carton(HC) bin box packaging

Part No.	UPC-A (032888)	Valve Size	Inner/Master Carton Qty.	Master Weight (lbs.)
Lever Handle				
110-522	105225	3/8"	10/100	32
110-523	105232	1/2"	10/100	40
110-524	105249	3/4"	10/100	61
110-525	105256	1"		
110-522HC	105225	3/8"	10/NA	3
110-523HC	105232	1/2"	30/NA	19
110-524HC	105249	3/4"	20/NA	24
110-525HC		1"		

Lever Handle – Steel

107-705	077058	1"	10/50	48
107-706	077065	1-1/4"	10/20	31
107-707	077072	1-1/2"	4/20	48
107-708	077089	2"	4/20	74

Tee Handle

111-523	115231	1/2"	10/100	39
111-524	115248	3/4"	10/100	51
111-525	115255	1"	6/36	40

Flat/Square Head

113-523	135239	1/2"	10/100	37
113-524	135246	3/4"	10/100	56
113-525	135253	1"	6/36	38
113-526	135260	1-1/4"	4/24	36
113-523HC	135239	1/2"	20/NA	8
113-524HC	139246	3/4"	20/NA	12

GAS HEATER BALL VALVE • ONE PIECE BODY

FORGED BRASS



- CSA- 3-88 (2 PSIG) Certified
- CSA Certified – Canadian Standards Association
- One piece body
- 9/16-24 fine flare thread for 3/8" tube
- Chrome plated forged brass ball
- Coated aluminum handle
- Threaded ends comply with ANSI B1.20.1

Part No.	UPC-A (032888)	Valve Size	I/M	Master Weight
117-592	175921	9/16" x 1/2"	10/100	34

GAS BALL VALVE • FLARE END • ONE PIECE BODY

FORGED BRASS



- Manufactured in an ISO 9001 facility
- CSA Z21 (15PSIG) Certified
- CSA Certified – Canadian Standards Association
- One piece body
- Chrome plated forged brass ball
- Coated aluminum handle
- Threaded ends comply with ANSI B1.20.1
- Available in Handy Carton (HC) bin box packaging

Part No.	UPC-A (032888)	Valve Size	Inner/Master Carton Qty.	Master Weight (lbs.)
Flare x Female				
114-522	145221	3/8" x 1/2"	10/100	34
114-523	145238	1/2" x 1/2"	10/100	37
114-524	145245	15/16" x 3/4"	10/100	58
114-543	145436	15/16" x 1/2"	10/100	40
114-544	145443	1/2" x 3/4"	10/100	41
Flare x Female Angle				
114-533	145337	3/8" x 1/2"	10/100	33
114-534	145344	15/16" x 3/4"	10/100	57

GAS BALL VALVE • FULL PORT • 600 PSI

FORGED BRASS

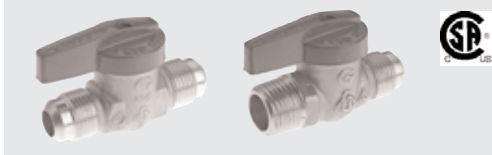

- Manufactured in an ISO 9001 facility
- CSA- 3-88 (2 PSIG) Certified
- CSA Certified – Canadian Standards Association
- One piece body
- Chrome plated forged brass ball
- Coated aluminum handle
- Threaded ends comply with ANSI B1.20.1

Part No.	UPC-A (032888)	Valve Size	Inner/Master Carton Qty.	Master Weight (lbs.)
Flare x Flare				
116-502	165021	3/8"	10/100	39
116-503	165038	1/2"	10/100	35
116-504	165045	5/8"	10/100	54
Flare x Male				
116-512	165120	3/8" x 1/2"	10/100	33
116-513	165137	1/2" x 1/2"	10/100	36

GAS BALL VALVE • FULL PORT • 600 PSI

FORGED BRASS



- Manufactured in an ISO 9001 facility
- CSA- 3-88 (2 PSIG) Certified
- CSA Certified – Canadian Standards Association
- Threaded 1/8" with plug for connection to a manometer
- Allows line pressure to be tested at the valve
- One piece body (through 3/4")
- Chrome plated forged brass ball
- Coated aluminum handle (3/8"-3/4")
- Dacromet steel plated handle (1")
- Threaded ends comply with ANSI B1.20.1

Part No.	UPC-A (032888)	Valve Size	Inner/Master Carton Qty.	Master Weight (lbs.)
Female x Female				
110-553	165539	1/2"	10/100	42
110-554	105546	3/4"	10/100	65
110-555	105553	1"	6/36	42
Flare x Flare				
116-552	165526	3/8"	10/100	43
116-553	165533	1/2"	10/100	40

GATE VALVE • 200 PSI

BRASS

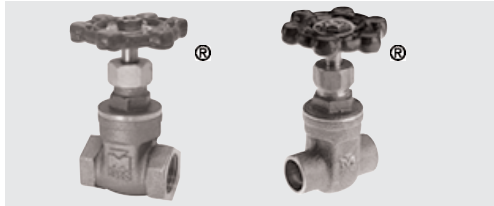

- 200 PSI Non-shock WOG
- 125 PSI WSP Steam
- Meets NSF approved low lead standards
- Full port
- Non-rising stem
- Cast iron handle
- Threaded ends comply with ANSI B1.20.1
- Solder ends comply with ANSI B16.18
- Available in Handy Carton (HC) bin box packaging

Part No.	UPC-A (032888)	Valve Size	Inner/Master Carton Qty.	Master Weight (lbs.)
Threaded				
100-001	000018	1/4"	10/100	60
100-002	000025	3/8"	10/100	66
100-003	000032	1/2"	10/100	68
100-004	000049	3/4"	5/60	53
100-005	000056	1"	5/40	47
100-006	000063	1-1/4"	5/30	55
100-007	000070	1-1/2"	4/24	52
100-008	000087	2"	2/16	54
100-009	000094	2-1/2"	2/8	55
100-010	000100	3"	1/6	49
100-011	000117	4"	1/3	44
Solder				
100-502	005020	3/8"	10/100	58
100-503	005037	1/2"	10/100	58
100-504	005044	3/4"	5/60	51
100-506	005068	1-1/4"	5/30	54
100-507	005075	1-1/2"	4/24	52
100-508	005082	2"	2/16	56
100-503HC	005037	1/2"	25/NA	15
100-504HC	005044	3/4"	25/NA	21
100-505HC	005051	1"	10/NA	12

STOP & WASTE VALVE • HEAVY DUTY • 150 PSI

BRASS



- Meets NSF approved low lead standards
- For use with water, oil or air
- Heavy construction
- Screw over bonnet
- Large flow area
- Large cast iron handle
- Allows draining of non-pressure side of valve when closed
- Threaded ends comply with ANSI B1.20.1
- Solder ends comply with ANSI B16.18

Part No.	UPC-A (032888)	Valve Size	Inner/Master Carton Qty.	Master Weight (lbs.)
Threaded				
105-183HC	050839	1/2"	12/NA	10
105-184HC	050846	3/4"	12/NA	12
Solder				
105-683HC	055834	1/2"	12/NA	9
105-684HC	055841	3/4"	12/NA	10

STOP & WASTE • COMPRESSION • 125 PSI

BRASS



- Meets NSF approved low lead standards
- CSA Certified – Canadian Standards Association
- For use with water, oil or air
- Compression ends for solderless connection to copper tubing
- Allows draining of non-pressure side of valve when closed

Part No.	UPC-A (032888)	Valve Size	Inner/Master Carton Qty.	Master Weight (lbs.)
105-613	056138	1/2" (5/8" O.D.)	12/72	46
105-614	056145	3/4" (7/8" O.D.)	6/36	32
105-613HC	056138	1/2" (5/8" O.D.)	16/NA	11
105-614HC	056145	3/4" (7/8" O.D.)	12/NA	11

BOILER DRAIN • 125 PSI

BRASS



- Easy quarter turn operation
- Maximum 125 PSI working pressure
- Meets NSF approved low lead standards
- UPC approved, complies to ASME A112.18.1 standards
- Chrome plated brass ball
- P.T.F.E. seats
- Rust resistant handle
- 3/4" hose thread outlet
- Pipe threads comply with ANSI B1.20.1
- Hose threads comply with ANSI B1.20.7
- Solder ends comply with ANSI-16.18
- Patent no. D486204S valve body
- Patent no. D472962 valve handle

Part No.	UPC-A (032888)	Valve Size	Inner/Master Carton Qty.	Master Weight (lbs.)
Male Threaded				
102-053HC ♂	000414	1/2"	25/NA	8
102-054HC §	000421	3/4"	25/NA	9

♂ = 1/2" Male external threads and 1/2" internal solder connection
 § = 3/4" Male boiler drain is tapped 1/2" female thread



BOILER DRAIN • 125 PSI**BRASS**

- Meets NSF approved low lead standards
- CSA Certified – Canadian Standards Association (102-003/004/003HC/004HC)
- 3/4" hose thread outlet
- Six lobe cast iron handle
- Pipe threads comply with ANSI B1.20.1
- Hose threads comply with ANSI B1.20.7
- Solder ends comply with ANSI B16.18
- Available in Handy Carton (HC) bin box packaging

Part No.	UPC-A (032888)	Valve Size	Inner/Master Carton Qty.	Master Weight (lbs.)
Male Threaded				
102-003 ◊	020030	1/2"	12/72	29
102-004	020047	3/4"	12/72	34
102-003HC ◊	020030	1/2"	40/NA	15
102-004HC	020047	3/4"	35/NA	16

Female Threaded

102-103	021037	1/2"	12/72	30
102-104	021044	3/4"	12/72	34
102-103HC	021037	1/2"	20/NA	17
102-104HC	021044	3/4"	35/NA	16

◊ = 1/2" Male external threads and 1/2" internal solder connection

BOILER DRAIN • 125 PSI**BRASS**

- Meets NSF approved low lead standards
- CSA Certified – Canadian Standards Association
- Heavy brass construction
- 3/4" hose thread outlet
- Six lobe cast iron handle
- Pipe threads comply with ANSI B1.20.1
- Hose threads comply with ANSI B1.20.7

Part No.	UPC-A (032888)	Valve Size	Inner/Master Carton Qty.	Master Weight (lbs.)
Male with locknut				
102-903 ◊	029033	1/2"	12/72	39

◊ = 1/2" Male external threads and 1/2" internal solder connection

BOILER DRAIN • COMPRESSION**BRASS**

- Rated for 125 psi working pressure
- Stuffing box
- 3/4" hose thread outlet
- Compression Connection
- Six lobe cast iron handle
- Hose threads comply with ANSI B1.20.7

Part No.	UPC-A (032888)	Valve Size	Inner/Master Carton Qty.	Master Weight (lbs.)
102-033	020337	1/2" (5/8" O.D.)	12/72	39

HOSE BIBB • QUARTER TURN • 125 PSI

FORGED BRASS



Part No.	UPC-A (032888)	Valve Size	Inner/Master Carton Qty.	Master Weight (lbs.)
103-053HC	◇ 000391	1/2"	25/NA	10
103-054HC	§ 000407	3/4"	25/NA	12

- Easy quarter turn operation
- Maximum 125 PSI working pressure
- Meets NSF approved low lead standards
- CSA Certified – Canadian Standards Association
- UPC approved, complies to ASME A112.18.1 standards
- Chrome plated brass ball
- P.T.F.E. seats
- Rust resistant handle
- 3/4" hose thread outlet
- Pipe threads comply with ANSI B1.20.1
- Hose threads comply with ANSI B1.20.7
- Solder ends comply with ANSI-16.18
- Patent no. D472962 valve handle
- Patent no. D5166785 valve body

◇ = 1/2" Male external threads and 1/2" internal solder connection
 § = Tapped 1/2" female thread

HOSE BIBB • BALL VALVE DESIGN • 200 PSI

FORGED BRASS



Part No.	UPC-A (032888)	Valve Size	Inner/Master Carton Qty.	Master Weight (lbs.)
103-023	◇ 030237	1/2"	10/100	43
103-024	030244	3/4"	10/100	56
103-023HC	◇ 030237	1/2"	20/NA	8
103-024HC	030244	3/4"	20/NA	11

- Rated for 200 PSI WOG
- Quarter turn operation
- Chrome plated brass ball
- 3/4" hose thread outlet
- Large flow rate
- Pipe threads comply with ANSI B1.20.1
- Hose threads comply with ANSI B1.20.7
- Available in Handy Carton (HC) bin box packaging

◇ = 1/2" Male external threads and 1/2" internal solder connection

SWING CHECK • "Y" PATTERN • 300 PSI

BRONZE

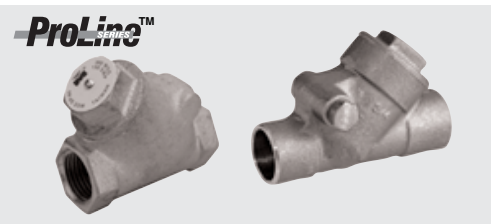

Part No.	UPC-A (032888)	Valve Size	Inner/Master Carton Qty.	Master Weight (lbs.)
Threaded				
101-203	012035	1/2"	10/120	73
101-204	012052	3/4"	10/80	79
101-205	012059	1"	10/60	78
101-206	012066	1-1/4"	5/30	59
101-207	012073	1-1/2"	4/24	71
101-208	012080	2"	2/16	78
Solder				
101-703	017030	1/2"	10/120	70
101-704	017047	3/4"	10/80	74
101-705	017054	1"	10/60	67
101-706	017061	1-1/4"	5/30	61
101-707	017078	1-1/2"	4/24	66
101-708	017085	2"	2/16	50

- 300 PSI Non-shock WOG
- 150 PSI WSP Steam
- Heavy bronze construction
- Screwed cap
- Swing type disc with integral seat
- P.T.F.E. face on disc for positive seal
- Can be installed vertically or horizontally
- Threaded ends comply with ANSI B1.20.1
- Solder ends comply with ANSI B16.18



SWING CHECK VALVE • 200 PSI

BRASS

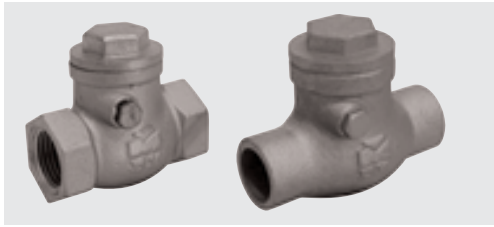

- 200 PSI non-shock WOG
- Meets NSF approved low lead standards
- Threaded ends comply with ANSI B1.20.1
- Solder ends comply with ANSI B16.18
- Available in Handy Carton (HC) bin box packaging

Part No.	UPC-A (032888)	Valve Size	Inner/Master Carton Qty.	Master Weight (lbs.)
Threaded				
I01-001	010017	1/4"	10/100	47
I01-002	010024	3/8"	10/100	41
I01-003	010031	1/2"	10/100	42
I01-004	010048	3/4"	5/60	33
I01-005	010055	1"	5/40	29
I01-006	010062	1-1/4"	5/30	42
I01-007	010079	1-1/2"	4/24	40
I01-008	010086	2"	2/16	45
I01-009	010093	2-1/2"	2/8	42
I01-010	010109	3"	1/6	44
I01-011	010116	4"	1/3	38
I01-003HC	010031	1/2"	20/NA	10
I01-004HC	010048	3/4"	20/NA	30
I01-005HC	010055	1"	25/NA	18
I01-006HC	010062	1-1/4"	15/NA	20
I01-007HC	010079	1-1/2"	12/NA	14
Solder				
I01-503	015036	1/2"	10/100	40
I01-504	015043	3/4"	5/60	33
I01-505	015050	1"	5/40	32
I01-506	015067	1-1/4"	5/30	43
I01-507	015074	1-1/2"	4/24	41
I01-508	015081	2"	2/16	45
I01-503HC	015036	1/2"	20/NA	9
I01-504HC	015043	3/4"	20/NA	13

RADIATOR GATE VALVE • 200 PSI

BRASS



- 60 PSI non-shock hot water & Rated for 15 PSI WSP
- For low pressure steam or circulated hot water
- Adjustable packing
- Rising stem & Heat resistant hand wheel

Part No.	UPC-A (032888)	Valve Size	Inner/Master Carton Qty.	Master Weight (lbs.)
I09-405	094055	1"	6/36	62
I09-406	094062	1-1/4"	6/24	60

FLOAT VALVES • 125 PSI

BRONZE

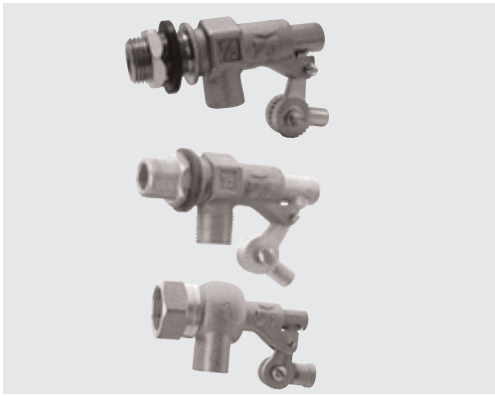

- Flange provides support against tank walls (male)
- Serrated arm allows easy adjustment of water level
- Pivot assembly prevents breakage during freezing
- Replaceable seals
- Locknut and washer included with male inlet valves
- Available in Handy Carton (HC) bin box packaging

Part No.	UPC-A (032888)	Valve Size	Rod Size	Inner/Master Carton Qty.	Master Weight (lbs.)
----------	----------------	------------	----------	--------------------------	----------------------

Male Inlet – Plain Outlet

109-802	098022	3/8"	1/4"-20"	12/72	42
109-803	098039	1/2"	1/4"-20"	12/72	56
109-804	098046	3/4"	1/4"-20"	6/36	40
109-803HC	098039	1/2"	1/4"-20"	12/NA	9
109-804HC	098046	3/4"	1/4"-20"	12/NA	12

Male Inlet – Male Outlet

109-813	098138	1/2"	1/4"-20"	12/72	58
109-814	098145	3/4"	1/4"-20"	6/36	41
109-813HC	098138	1/2"	1/4"-20"	12/NA	9
109-814HC	098145	3/4"	1/4"-20"	12/NA	12

Female Inlet – Plain Outlet

109-805	098053	1"	5/16"-18"	4/24	42
109-806	098060	1-1/4"	3/8"-16"	2/16	49
109-807	098077	1-1/2"	3/8"-16"	2/12	37
109-808	098084	2"	3/8"-16"	2/12	41

TANK FLOAT

COPPER • PLASTIC

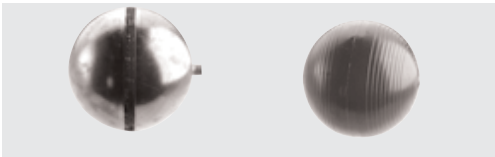

109-871-874

- High grade copper construction
- Bonded overlapping joints

109-861-864

- Polystyrene construction
- Corrosion resistant
- Impact resistant

Part No.	UPC-A (032888)	Material	Float Size	Rod Thread	Inner/Master Carton Qty.	Master Weight (lbs.)
109-871	098718	Copper	5"	1/4"-20"	1/NA	.5
109-872	098725	Copper	6"	1/4"-20"	1/NA	1
109-873	098732	Copper	8"	5/16"-18"	1/NA	2
109-874	098749	Copper	8"	3/8"-16"	1/NA	2
109-861	098619	Plastic	5"	1/4"-20"	1/64	33
109-862	098626	Plastic	6"	1/4"-20"	1/40	26
109-863	098633	Plastic	8"	5/16"-18"	1/17	20
109-864	098749	Plastic	8"	3/8"-16"	1/17	20

TANK FLOAT RODS

BRASS



- Solid brass
- Threaded on both ends

Part No.	UPC-A (032888)	Rod Length	Rod Thread	Inner/Master Carton Qty.	Master Weight
109-851	098510	10"	1/4"-20"	5/250	50
109-852	098527	12"	1/4"-20"	5/250	61
109-853	098534	12"	5/16"-18"	5/250	50
109-855	098558	12"	3/8"-16"	5/200	58



EVAPORATIVE COOLER VALVE

BRASS



Part No.	UPC-A (032888)	Valve Size	Inner/Master Carton Qty.	Master Weight (lbs.)
102-194	021945	3/4"	12/72	36
102-194HC	021945	3/4"	12/NA	6

- 3/4" hose thread inlet and outlet
- Six lobe cast iron handle
- 1/8" female pipe thread side tap for connection to air conditioner
- Pipe threads comply with ANSI B1.20.1
- Hose threads comply with ANSI B1.20.7
- Available in Handy Carton (HC) bin box packaging

EVAPORATIVE COOLER FLOAT VALVE • HEAVY DUTY

BRASS



Part No.	UPC-A (032888)	Valve Size	Inner/Master Carton Qty.	Master Weight (lbs.)
109-901	099012	1/4"	20/80	30

- Brass body and rod
- 1/4" compression inlet
- Polyfloat included
- Packaged one set per polybag

OIL TANK VALVE • BOTTOM SUPPLY

BRASS



Part No.	UPC-A (032888)	Valve Size	Inner/Master Carton Qty.	Master Weight (lbs.)
109-241	092419	1/2" x 3/8"	6/72	63

- 1/2" MIP X 3/8" MIP
- Brass to brass seat
- Cast iron handle
- Threads comply with ANSI B1.20.1

ICE MAKER • HUMIDIFIER KIT

COPPER • PLASTIC

- Self piercing saddle valve
- 25' of tubing
- Allows complete connection from water line to appliance
- 993-012 - 15' of tubing



Part No.	UPC-A (032888)	Tubing Type	Inner/Master Carton Qty.	Master Weight (Lbs.)
993-001	930018	Plastic	1/25	17
993-002	930025	Copper	1/25	42
993-012	685768316954	Copper	1/15	13

SADDLE TEES

BRASS • STEEL



Part No.	UPC-A (032888)	Type	Inner/Master Carton Qty.	Master Weight (Lbs.)
993-004	930049	Self Piercing	10/50	27
993-014	930148	Standard	50/250	48

- Fits 3/8" through 1-1/4" tubing
- Outlet fits 1/4" copper or poly tubing

Filter Driers



Offering total system protection, Mueller's DRYMASTER® Plus Filter Driers guarantee durability in the most aggressive environmental applications. Incorporating engineering skill and knowledge, this product line continues to evolve after many years of inclusion within Mueller's product offering. Select Mueller to offer a drier that meets the demands of high pressure refrigerants while providing optimum protection from contaminants in refrigeration and air conditioning systems.



- Solid core design, composed of 80% molecular sieves / 20% activated alumina on liquid line models, and 70% activated alumina / 30% molecular sieves on suction line (burnout) models, for exceptional moisture and acid removal.
- High retention filter for removal of particulate as small as 25 microns.
- High-pressure shell and connections designed for MWP up to 610 psig.
- Powder-paint finish, approved for marine applications.
- Tested for all CFC/HCFC/HFC refrigerants (including R 410A) with POE and PAG oils.
- All driers are UL/cUL listed.
- Compatible with refrigerants requiring XH11 dessicant.

DRYMASTER® PLUS FILTER DRIERS-LIQUID LINE

DRYMASTER® PLUS LIQUID LINE FILTER DRIERS WITH FLARE CONNECTION

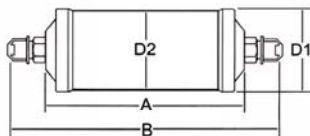

Flare Connection

Part No.	Model Number	Cubic Inches	Connection Size	Max. Working Pressure	A	B	DI	D2
A 16600	FL-032	3	1/4	610	2.48	4.35	2.25	2.12
A 16601	FL-033	3	3/8	610	2.48	4.85	2.25	2.12
A 16606	FL-052	5	1/4	610	2.88	4.68	2.25	2.12
A 16607	FL-053	5	3/8	610	2.88	5.20	2.25	2.12
A 16608	FL-082	8	1/4	610	3.89	5.72	2.25	2.12
A 16609	FL-083	8	3/8	610	3.89	6.51	2.25	2.12
A 16610	FL-084	8	1/2	610	3.89	6.51	2.25	2.12
A 16612	FL-162	16	1/4	610	4.22	6.05	3.17	2.98
A 16613	FL-163	16	3/8	610	4.22	6.58	3.17	2.98
A 16614	FL-164	16	1/2	610	4.22	6.91	3.17	2.98
A 16615	FL-165	16	5/8	610	4.22	7.25	3.17	2.98
A 16618	FL-303	30	3/8	610	7.24	9.59	3.17	2.98
A 16619	FL-304	30	1/2	610	7.24	9.91	3.17	2.98
A 16620	FL-305	30	5/8	610	7.24	10.23	3.17	2.98
A 16623	FL-413	41	3/8	610	7.44	9.64	3.67	3.51
A 16624	FL-414	41	1/2	610	7.44	9.94	3.67	3.51
A 16625	FL-415	41	5/8	610	7.44	10.28	3.67	3.51

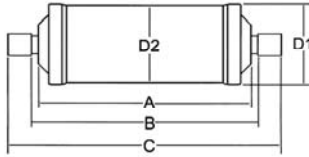

DRYMASTER® PLUS FILTER DRIERS-LIQUID LINE**DRYMASTER® PLUS LIQUID LINE FILTER DRIERS WITH SOLDER CONNECTION**

Solder Connection

Part No.	Model Number	Cubic Inches	Connection Size	Max. Working Pressure	A	B	C	D1	D2
A 16640	SD-032	3	1/4	610	2.48	3.23	3.85	2.25	2.12
A 16641	SD-033	3	3/8	610	2.48	3.36	3.98	2.25	2.12
A 16646	SD-052	5	1/4	610	2.88	3.58	4.20	2.25	2.12
A 16647	SD-053	5	3/8	610	2.88	3.75	4.37	2.25	2.12
A 16648	SD-082	8	1/4	610	3.89	4.61	5.23	2.25	2.12
A 16649	SD-083	8	3/8	610	3.89	4.74	5.36	2.25	2.12
A 16650	SD-084	8	1/2	610	3.89	4.75	5.51	2.25	2.12
A 16653	SD-163	16	3/8	610	4.22	5.09	5.71	3.17	2.98
A 16654	SD-164	16	1/2	610	4.22	5.10	5.86	3.17	2.98
A 16655	SD-165	16	5/8	610	4.22	5.28	6.28	3.17	2.98
A 16657	SD-166	16	3/4	500	4.22	5.51	6.75	3.17	2.98
A 16656	SD-167	16	7/8	500	4.22	5.35	6.85	3.17	2.98
A 16658	SD-303	30	3/8	610	7.24	8.07	8.69	3.17	2.98
A 16659	SD-304	30	1/2	610	7.24	8.13	8.89	3.17	2.98
A 16660	SD-305	30	5/8	610	7.24	8.27	9.27	3.17	2.98
A 16662	SD-307	30	7/8	500	7.24	8.15	9.65	3.17	2.98
A 16661	SD-309	30	1-1/8	500	7.24	8.15	9.97	3.17	2.98
A 16663	SD-413	41	3/8	610	7.44	8.23	8.85	3.67	3.51
A 16664	SD-414	41	1/2	610	7.44	8.19	8.95	3.67	3.51
A 16665	SD-415	41	5/8	610	7.44	8.31	9.31	3.67	3.51
A 16667	SD-417	41	7/8	500	7.44	8.39	9.89	3.67	3.51
A 16668	SD-419	41	1-1/8	500	7.44	8.19	10.01	3.67	3.51

DRYMASTER® PLUS FILTER DRIERS-SUCTION LINE**DRYMASTER® PLUS SUCTION LINE FILTER DRIERS, FLARE CONNECTION**

Nominal capacity (tons)
Evaporator temperature 40°F

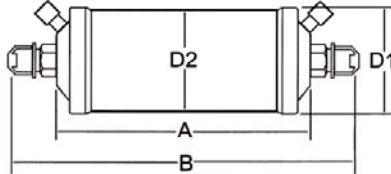

Part No.	Number	Model Inches	Cubic Size	Pressure	Max Working			R22		D1	D2
					R 134a	R 507	R 404A	R 407C			
A 17225	FD-164-TT	16	1/2	610	1.70	2.40	3.00	4.3	6.9	3.1	3
A 17226	FD-165-TT	16	5/8	610	2.70	3.70	4.30	4.3	7.2	3.1	3

DRYMASTER® PLUS FILTER DRIERS-SUCTION LINE



DRYMASTER® PLUS SUCTION LINE FILTER DRIERS, SOLDER CONNECTION

Nominal capacity (tons)
Evaporator temperature 40°F

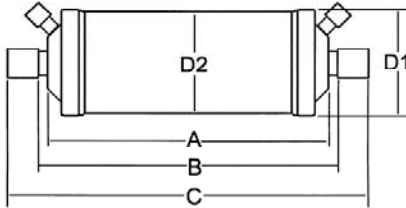

Part No.	Number	Model Inches	Cubic Size	Max Working Pressure	R22							
					R 404AR	134aR	507	R410A	A	B	C	DI
A 17224	FDS-164-TT	16	1/2	610	1.70	2.40	3.00	4.3	4.6	6.0	3.1	3
A 17227	FDS-165-TT	16	5/8	610	2.70	3.70	4.30	4.3	4.6	6.2	3.1	3
A 17228	FDS-166-TT	16	3/4	510	3.40	4.90	5.70	4.3	4.6	6.7	3.1	3
A 17229	FDS-167-TT	16	7/8	510	3.90	5.40	6.30	4.3	4.7	6.8	3.1	3
A 17230	FDS-169-TT	16	1-1/8	510	4.60	6.50	7.50	4.3	4.7	6.8	3.1	3
A 17231	FDSF-309-TT	30	1-1/8	510	5.70	7.70	8.90	7.3	7.7	9.8	3.1	3
A 17300	FDS-305-TT	30	5/8	610	3.10	4.30	5.10	7.3	7.6	9.2	3.1	3
A 17301	FDS-306-TT	30	3/4	510	4.00	5.40	6.30	7.3	7.6	9.7	3.1	3
A 17302	FDS-307-TT	30	7/8	510	4.60	6.30	7.40	7.3	7.7	9.8	3.1	3
A 17232	FDS-3011-TT	30	1-3/8	360	5.70	7.70	8.90	7.3	8.6	10.5	3.1	3
A 17233	FDS-3013-TT	30	1-5/8	360	5.70	7.70	8.90	7.3	8.7	11.3	3.1	3

DRYMASTER PLUS® FILTER DRIERS-HEAT PUMP



- May be mounted in any position.
- Provides in-depth filtration.
- Internal construction allows reversible refrigerant flow.
- No external check valves required.
- Reduces cost by eliminating system complexity.
- UL listed for use in the USA and Canada.

Solder Type

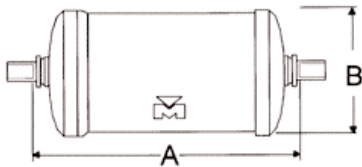

Flare Type

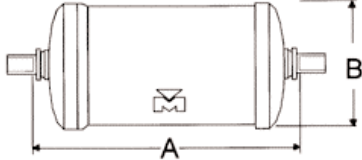

Part No.	Model No.	Fitting Size	Cu. In. Vol.	A	Diameter B
A 17388	HPF-083	3/8 Flare	8	6-1/4	2-1/4
A 17389	HPS-083	3/8 Solder	8	5-5/8	2-1/4
A 17390	HPF-163	3/8 Flare	16	6-3/4	3-1/8
A 17391	HPS-163	3/8 Solder	16	5-7/8	3-1/8
A 17392	HPS-164	1/2 Solder	16	6-1/8	3-1/8
A 17983	HPF-164	1/2 Flare	16	7	3-1/8
A 17984	HPF-165	5/8 Flare	16	7-3/8	3-1/8
A 17985	HPS-165	5/8 Solder	16	6-3/8	3-1/8



Strainers



Mueller's strive for excellence brings forth another growing product line. Offering the flexibility of configuration and material construction, it is now possible to efficiently and economically protect refrigeration and water systems. Included are cast bronze, brass y-type and inline copper strainers. Depend on Mueller's engineering advancements for the development of new industry expectations.



TUBE & PIPE

METAL FITTINGS & NIPPLES

PLASTIC FITTINGS

VALVES

FILTER-DRYERS & STRAINERS

WATER STRAINER

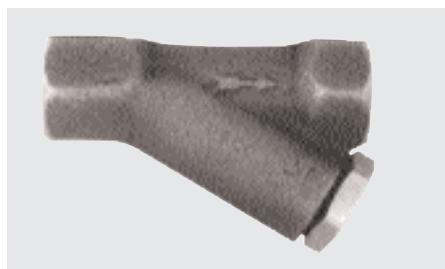

- Suitable for refrigeration and water systems.
- Cast Bronze construction for efficient and economical inline installation.
- Maximum temperature of 200°F.

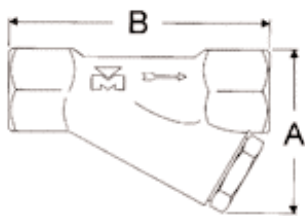

Replacement screen for Y-Type strainers

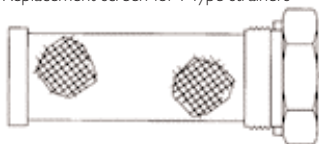

These sub-assemblies consist of a screen, a plug and an o-ring.

Recommended for the protection of condensing water regulators, water coolers, dispensing equipment and similar applications.

Y-TYPE-THREADED

Part No.	Size NPTI x NPTI	Dim A	Dim B	Screen Mesh	Sq. In. Screen Area	Wt./Ea.
A 15176	3/8	2-3/16	3-5/16	50	3-1/2	.68
A 15184	3/8	2-3/16	3-3/8	100	3-1/2	.68
A 15177	1/2	2-3/16	3- 5/16	50	3-1/2	.66
A 15159	1/2	2-3/16	3-3/8	100	3-1/2	.66
A 15178	3/4	3	4-7/16	50	6-1/2	1.42

Y-TYPE-SOLDER TO SOLDER

Part No.	Size NPTI x NPTI	Dim A	Dim B	Screen Mesh	Sq. In. Screen Area	Wt./Ea.
A 15192	3/8	2-3/16	3-9/32	50	3-1/2	.78
A 15196	3/8	2-3/16	3-9/32	100	3-1/2	.78
A 15193	1/2	2-3/16	3-9/32	50	3-1/2	.72
A 15197	1/2	2-3/16	3-9/32	100	3-1/2	.72
A 15194	3/4	3	4-7/16	50	6-1/2	1.47

REPLACEMENT SCREEN SUB-ASSEMBLIES FOR Y-TYPE STRAINERS

Part No.	Screen Mesh	For Use With Assembly Numbers
A 15122	100	A 15159, A 15184, A 15196, and A 15197,
A 15123	50	A 15176, A 15177, A 15192, and A 15193,
A 15124	50	A 15178 and A 15194



INLINE Y STRAINER

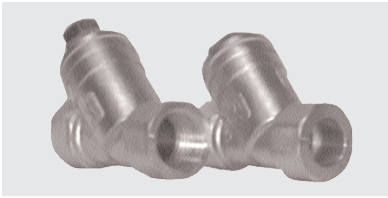

- Solder Connection Sizes 1/4 thru 2-1/2".
- Threaded Connection Sizes 1/4 - 2-1/2".
- Flexible design offers interchangeable cap and mesh size options as part of the standard product offering.
- Compatible with all CFC, HCFC and HFC refrigerants and oils.
- Wide operating temperature range of -40°F to 300°, and working pressure up to 700 psig.

Maintenance Cap Option

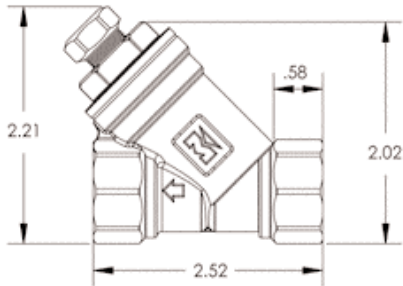

Solid Cap Option

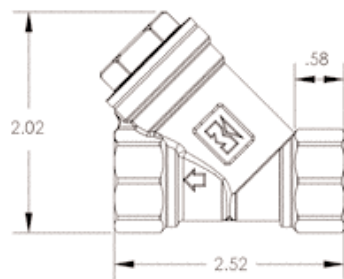

Part Number **	Plumbing System		Refrigeration System		Type	Cap, Screen & Gasket Rebuild Kit **
	Size	Compatibility	Size	Compatibility		
A 18069	1/4	Yes	3/8	Yes	1/4 - 18 NPT	
A 18070	1/4	Yes	3/8	Yes	Solder Cup	
A 18071	3/8	Yes	1/2	Yes	3/8 - 18 NPT	A 18080
A 18072	3/8	Yes	1/2	Yes	Solder Cup	
A 18073	1/2	Yes	5/8	Yes	1/2 - 14 NPT	
A 18074	1/2	Yes	5/8	Yes	Solder Cup	

* Prefix required for Cap Option

** Prefix required for Screen Option
Additional sizes to be released.

Contact factory for more details, or check www.muellerindustries.com for current data.

Prefixed for Cap Options:

M = Maintenance Cap

S = Solid Cap

Prefixed for Screen

Mesh Options:

F = 20

G = 40

H = 50

I = 60

J = 80

K = 100

Examples:

AMF18069, 1/4 Threaded Y-Strainer with Maintenance Cap, 20 Mesh Screen

ASF18069, 1/4 Threaded Y-Strainer with Solid Cap, 20 Mesh Screen

AMF18070, 1/4 Solder Y-Strainer with Maintenance Cap, 20 Mesh Screen

ASF18070, 1/4 Solder Y-Strainer with Solid Cap, 20 Mesh Screen

MCC INLINE STRAINER



- Connection Sizes 1/4 thru 5/8".
- Screens available in 80, 100 and 120 mesh.
- Internal components constructed of brass and stainless steel.
- Resistant to high pressure, turbulent and pulsating flow conditions.
- Compatible with all CFC, HCFC and HFC refrigerants and oils.
- Wide operating temperature range of -40° F to 300°F, and working pressure up to 700 psig.
- All strainers are UL/cUL recognized.

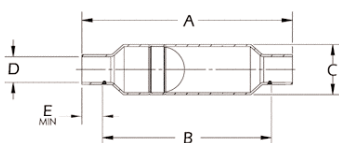

Part Number	Size	A (in)	B (in)	C (in)	D (in)	E (in)	Internal			Filtration Capacity (micron)
							Assembly Volume	Screen Mesh	Screen Area	
A 18020	1/4	2.77	2.15	0.75	1/4	0.31	.655	80	0.4	240
A 18021	3/8	3.12	2.50	0.75	3/8	0.31	.790	80	0.4	240
A 18022	1/2	3.01	2.25	1.00	1/2	0.38	1.25	80	1.0	240
A 18023	5/8	3.50	2.50	1.00	5/8	0.50	1.54	80	1.0	240
A 18024	1/4	2.77	2.15	0.75	1/4	0.31	.655	100	0.4	175
A 18025	3/8	3.12	2.50	0.75	3/8	0.31	.790	100	0.4	175
A 18026	1/2	3.01	2.25	1.00	1/2	0.38	1.25	100	1.0	175
A 18027	5/8	3.50	2.50	1.00	5/8	0.50	1.54	100	1.0	175
A 18028	1/4	2.77	2.15	0.75	1/4	0.31	.655	120	0.4	140
A 18029	3/8	3.12	2.50	0.75	3/8	0.31	.790	120	0.4	140
A 18030	1/2	3.01	2.25	1.00	1/2	0.38	1.25	120	1.0	140
A 18031	5/8	3.50	2.50	1.00	5/8	0.50	1.54	120	1.0	140

INDEX BY DESCRIPTION

Copper Tube 2–4	
Copper Tube Plumbing	..2
Copper Tube Refrigeration	..3
Plastic Coated Copper Tube	..3

Copper Fittings	
Wrot & Cast Pressure Fittings	
45° Elbow	..15–16
45° Wye	..37
90° Elbow	..15–20
Adapter	..8–11
Bushing	..11–12
Cap	..12
Copper Strap	..29
Coupling	..12–15
Cross	..15
Fitting Reducer	..21
Flange	..27
Hanger	..29
Plug	..22
P-Trap	..22
Return Bend	..22–23
Tee	..23–28
Union	..28

Iron Fittings	
45° Elbow	..30
45° Street Elbow	..31
90° Elbow	..31
90° Reducing Elbow	..32
90° Street Elbow	..31
Cap	..37
Coupling	..35
Cross	..40
Extension Piece	..32
Floor Flange	..39
Hex Bushing	..38
Locknut	..40
Merchant Coupling	..37
Plug	..37
Reducing Coupling	..36
Reducing Tee	..34–35
Side Outlet Elbow	..33
Service Tee	..33
Tee	..33
Union	..39

Steel Nipples	
Pipe Nipple Assortment	..48
Pre-Cut Pipe 1/4"	..46
Pre-Cut Pipe 3/8"	..46
Pre-Cut Pipe 1/2"	..46
Pre-Cut Pipe 3/4"	..46
Pre-Cut Pipe 1"	..46
Pre-Cut Pipe 1-1/4"	..46
Pre-Cut Pipe 1-1/2"	..46
Pre-Cut Pipe 2"	..46
Seamless Steel Pipe Nipples 1/8"	..49
Seamless Steel Pipe Nipples 1/4"	..49
Seamless Steel Pipe Nipples 3/8"	..49
Seamless Steel Pipe Nipples 1/2"	..50

Tube & Pipe

Line Sets 4–5	
Line Sets	..5
Line Sets Schematic	..4
Mini Split Line Sets	..5

Pipe 6–7	
10 Ft Threaded	..6
21 Ft Threaded & Coupled	..6
ABS DWV Pipe	..7

Metal Fittings & Nipples

Seamless Steel Pipe Nipples 3/4"	..50
Seamless Steel Pipe Nipples 1"	..50
Seamless Steel Pipe Nipples 1-1/2"	..51
Seamless Steel Pipe Nipples 2"	..51
Seamless Steel Pipe Nipples 2-1/2"	..51
Seamless Steel Pipe Nipples 3"	..52
Seamless Steel Pipe Nipples 4"	..52
Seamless Steel Pipe Nipples 6"	..52
Welded Steel Pipe Nipple 1/8"	..41
Welded Steel Pipe Nipple 1/4"	..41
Welded Steel Pipe Nipple 3/8"	..42
Welded Steel Pipe Nipple 1/2"	..42
Welded Steel Pipe Nipple 3/4"	..42
Welded Steel Pipe Nipple 1"	..43
Welded Steel Pipe Nipple 1-1/4"	..43
Welded Steel Pipe Nipple 1-1/2"	..43
Welded Steel Pipe Nipple 2"	..44
Welded Steel Pipe Nipple 2-1/2"	..44
Welded Steel Pipe Nipple 3"	..44
Welded Steel Pipe Nipple 4"	..45
Welded Steel Pipe Nipple 6"	..45
XH Steel Pipe Nipples 1/8"	..53
XH Steel Pipe Nipples 1/4"	..53
XH Steel Pipe Nipples 3/8"	..53
XH Steel Pipe Nipples 1/2"	..54
XH Steel Pipe Nipples 3/4"	..54
XH Steel Pipe Nipples 1"	..54
XH Steel Pipe Nipples 1-1/4"	..55
XH Steel Pipe Nipples 1-1/2"	..55
XH Steel Pipe Nipples 2"	..55
XH Steel Pipe Nipples 2-1/2"	..55–56
XH Steel Pipe Nipples 3"	..56
XH Steel Pipe Nipples 4"	..56
XH Steel Pipe Nipples 6"	..56

Red Brass Fittings	
45° Elbow	..58
45° Street Elbow	..58
90° Elbow	..57
90° Reducing Elbow	..58
90° Street Elbow	..57
Cap	..61
Cored Plug	..61
Coupling	..59
Cross	..59
Hex Bushing	..60
Locknut	..60
Reducing Coupling	..60
Reducing Tee	..59
Solid Plug	..61
Tee	..59
Union	..61

Red Brass Nipples	
Nipple 1/8"	..62
Nipple 1/4"	..62

Nipple 3/8"	..62
Nipple 1/2"	..63
Nipple 3/4"	..63
Nipple 1"	..63
Nipple 1-1/4"	..64
Nipple 1-1/2"	..64
Nipple 2"	..64

Yellow Brass Fittings	
45° Elbow	..65
45° Street Elbow	..65
90° Elbow	..65
90° Street Elbow	..65
Cap	..66
Coupling	..66
Face Bushing	..66
Hex Bushing	..66
Solid Plug	..66
Tee	..65

Yellow Brass Nipples	
Nipple 1/8"	..67
Nipple 1/4"	..67
Nipple 3/8"	..67

Flare Brass Fittings & Flanges	
90° Elbow, Union	..73
90° Elbow	..72
90° Solder Elbow	..73
90° Elbow	..73-74
90° Swivel Elbow	..74
Bushing	..76
Connectors	..69
Flare Gasket	..75
Flare Seal Bonnet	..75
FLange	..76-77
Flare Plugs	..75
Flare Seal Cap	..76
Fusible Pipe Flugs	..72
Gasket	..78
Half Union	..70-71
Swivel Unions	..71
Flare to Extension	..69
FLare Union	..71
Internal Flare Unions	..71
Long Forged Nuts	..68
Pipe Plugs-Brass	..76
Reducing Unions	..70
Refrigerant Drum Adapter	..72
Right Angle Two-Way Tee	..74
Short Forged Nut	..68
Reducing Nut	..68
Three-Way Tee	..74-75
Three-Way Reducing Tee	..75
Two-Way Tee	..74
Union	..69



INDEX BY DESCRIPTION

Schedule 40

45° Elbow	82
90° Elbow	80-81
Adapter	83-84
Bushing	84-85
Cap	85-86
Coupling	82-83
Cross	82
Deep Socket Coupling	87
Plug	86
P-Trap	87
Riser	83
Tee	78-79
Union	87
Insert Fittings	
90° Cap	90
90° Elbow	90
Adapter	88-89
Bushing	89
Coupling	90

Refrigeration Valves

CYCLEMASTER® Actuated Valves	153
CYCLEMASTER® Ball Valves	154
Check Valves	162
CMV Series Magnetic Check Valves	163
Compressor Valves & Kits	158-161
Hi-Flow Residential Check Valves	163
Mueller Angle Isolation Valves	166
Packed Line Valves	155-156
Packless Diaphragm Valves	157
Pressure Relief Valves	165
Reliefmaster Change-Over Manifold	166
Rupture Disc	164

Filter Driers

Drymaster® Plus Filter Driers	177-179
Drymaster® Plus Heat Pump Filters	181

Plastic Fittings

ABS DWV Fittings

Adapter	91-99
Bushing	95
Cap	97,99
Closet Flange	118-121
Coupling	99
Drum Trap	148
Elbows	100-107
Nut	99,130
Pipe Increaser	92
Plug	94-95
P-Trap	117-118
Return Bend	116
Swivel Tray Plug Adapter	122
Tail Piece Adapter	146
Tee	107-111
Trap Adapter	92-94
Washer	100
Wye	111-116

Valves

Screw Bonnet Check Valves	164
Plumbing Valves	
Ball Valves	167-213
Ball Valves – Brass	167-168
Ball Valves – PVC	170
Ball Valves – CPVC	171
Boiler Drains	172-173
Boiler Drains – Brass	171-172
Evaporative Cooler Valve	176
Evaporative Cooler Float Valves	176
Float Rods	176
Float Valves	175
Gas Valves	168-170

Filter Driers & Strainers

Strainers

Water Strainer	180
Inline Y Strainer	183
MCC Inline Strainer	183

PVC DWV Fittings

Adapter	128-126, 128-131
Bushing	127,130
Cap	129-130
Closet Flange	149-152
Coupling	123,130,132
Drum Trap	149
Elbows	133-137
Nut	130,132
Pipe Increaser	124
Plug	126, 128
P-Trap	148
Return Bend	147
Swivel Tray Plug Adapter	152
Tail Piece Adapter	147
Tee	137-142
Trap Adapter	154-155
Wye	142-147

Gate Valves – Brass	170
Hose Bibbs – Brass	173
Oil Tank Valve	177
Radiator Valves – Brass	174
Stop & Waste Valves – Brass	171
Swing Check Valves	173-174
Tank Floats	175
Specialities	
Ice Maker Humidifier Kit	176
Saddle Tee	176
Pipe Cutter	178
Pipe Cutter Blade, Replacement	178

TUBE & PIPE

METAL FITTINGS & NIPPLES

PLASTIC FITTINGS

VALVES

FILTER-DRIERS & STRAINERS



