



201 Ivyland Road
Ivyland, PA
18974

Phone: 215-322-0730
Fax: 800-322-5519
Web: www.hartell.com
Email: info@hartell.com

A2-X-1965 DV

Plenum Rated* - Dual Voltage Capable
Commercial Grade Condensate Removal Pump

**I N S T A L L A T I O N , O P E R A T I O N
& M A I N T E N A N C E**

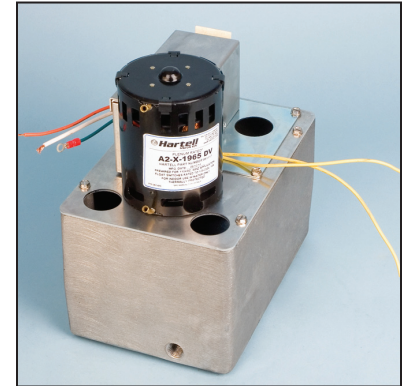

INTRODUCTION

HARTELL condensate pumps are designed to collect and automatically remove the water produced by an air conditioner evaporative coil and/or a gas-condensing furnace. This pump has been carefully engineered to provide long, trouble free service and is of the highest quality workmanship and materials.

These pumps have been thoroughly inspected and tested, then carefully packaged to insure safe delivery and operation. When you receive your pump, examine it carefully to determine that there are no damaged or broken parts. If damage is detected, notify the firm from where the pump was purchased. They will assist with a repair or replacement.

See the precautions listed below before continuing.

CAUTION: READ ALL INSTRUCTIONS CAREFULLY BEFORE STARTING INSTALLATION

- Pump should only be used with liquids compatible with pump component materials. Do not use to pump flammable or explosive fluids. Do not use in explosive atmospheres.
- The pump is designed for grounded installation. To reduce the risk of electrical shock be certain that it is connected to a properly grounded, grounding receptacle.
- In any installation where property damage and/or personal injury might result from an inoperative or leaking pump due to power outages, discharge line blockage, or any other reason, a back up system(s) (aux. switch and/or alarm) should be used.
- Do not handle pump with wet hands or when standing on a wet or damp surface, or in water.
- Shut off the electrical power at the fuse box before making any connections. All wiring must comply with local codes.

ONE YEAR LIMITED WARRANTY

HARTELL'S A2-X-1965 DV series condensate pump is guaranteed to be free from defects in workmanship or materials and to function satisfactorily, when properly installed, for a period of ONE (1) year from date of installation. See our website for additional warranty information at www.hartell.com.

This guarantee does not apply if the product has been misapplied or mechanically damaged, HARTELL assumes no liability for resultant damages of any kind arising out of the use of its products.

INSTALLATION

Carefully unpack the pump. Choose a location for its installation keeping in mind that the pump must be level and its inlet must be below the lowest drain, either coil or furnace. Remove and discard the tagged shipping screw that is located on the end of the switch cover box. This releases the float for fully automatic operation.

PIPING—Run flexible tubing or pipe from the evaporator and furnace to the pump. Insert the pipe into the drain inlet hole. Make sure the pipe does not interfere with the float. Cut an angle on the inlet pipe so that it doesn't close off against the bottom of the pump. See Figure 1 – exploded detail.

Connect 3/8" NPT piping to the discharge port. Extend this piping or tubing straight up as high as necessary. (Do not extend this tubing past the head/GPH of the pump installed). Do not kink the tubing, as this will block the flow. From this high point, slope the discharge tubing downward to a point above the drain, then turn down and extend to a point below or level with the bottom of the condensate pump. If it is not possible to slope the discharge tubing downwards, make an inverted "U" trap directly above the pump at the highest point. (Figure 1)

A check valve is required and should be of a soft seat swing check design. A spring loaded ball check is permissible if the lift is one half of the pump shut off level and the spring pressure is equal to, or less than one (1) psi.

ELECTRICAL CONNECTIONS— Review precautions on previous page before proceeding!

LINE VOLTAGE—Connect only to a source of constant power, not an intermittent source such as a fan or limit control circuit. Connect the black and white wires to the appropriate voltage source and the green wire to ground.

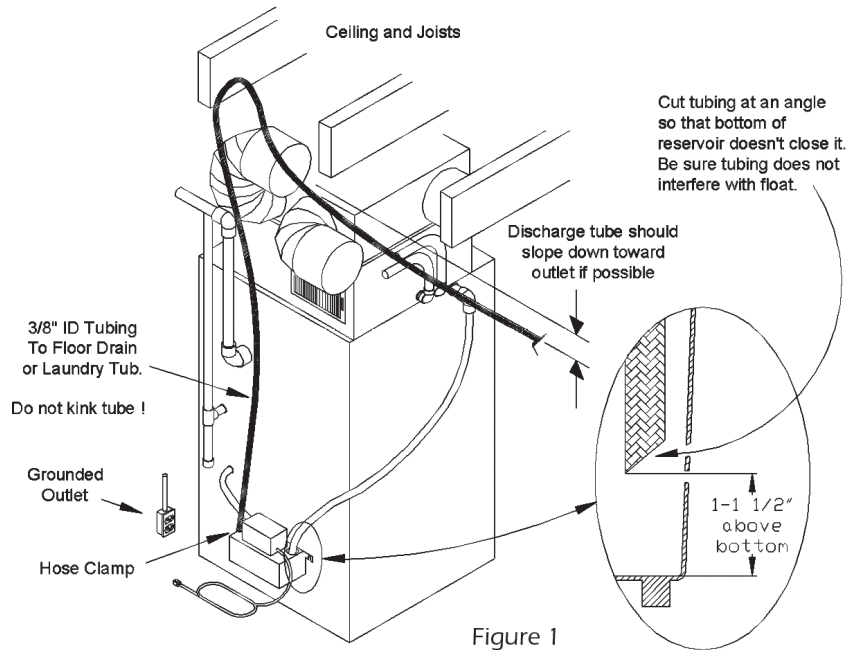

Figure 1

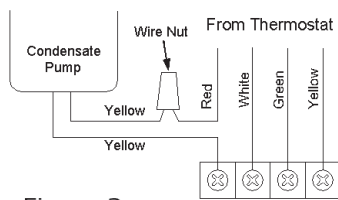

Figure 2

The A2-X-1965 is equipped with a **LOW VOLTAGE—AUXILIARY SAFETY SWITCH**—Connect the leads of the auxiliary safety switch to the thermostat control circuit of the air conditioner/furnace. This will disrupt the thermostat demand in a high water condition. (Figure 2)

CAUTION—Thermostat demand disruption should not be utilized if cooling or heating requirements are a necessity. An alarm system should be used with the auxiliary switch instead.

A2-X-1965 WIRING FOR DUAL VOLTAGE—The A2-X-1965 Dual Voltage Condensate pump is wired for 115 volts from the manufacturer. NOTE: read entire procedure before starting.

To connect to 115 VAC power supply, wire as follows.

1. Remove the top switch cover plate.
2. Install a proper conduit fitting thru the side hole of the main switch cover and feed the power supply wires and thermostat control leads (optional) into the housing.
3. Connect the orange and white wire to the power supply lines.
4. Connect the green (ground) wire to the ground supplied.
5. Connect the yellow auxiliary wires as previously described to the thermostat control circuit leads.
6. Replace the top switch cover plate.

To connect to 230 VAC power supply, wire as follows. (Figure 3)

1. Remove the entire switch cover.
2. Remove the blue/yellow motor wire connector from the switch.
3. Cut the female connector from the blue/yellow motor wires.
4. Cut the wire connector from the black/red motor wires.

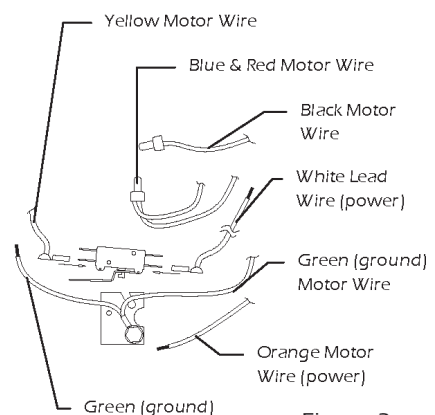

Figure 3

5. Strip the yellow motor wire and install a 1/4 in. female connector.
6. Place the yellow motor wire onto the switch as shown.
7. Strip the red and blue motor wires and connect together with wire nut.
8. Strip the black motor wire and add a wire nut to insulate.
9. Replace the main switch cover ensuring wires are clear of switches and accessible through the top cover plate
10. Remove top switch cover plate.
11. Install a proper conduit fitting thru the side hole of the main switch cover and feed the power supply wires and the thermostat control leads (optional) into housing.
12. Connect the orange and white wires to the 230 volt power supply.
13. Connect the green (ground) wire to the ground source.
14. Connect the yellow auxiliary wires as previously described to the thermostat control circuit leads
15. Replace the switch cover top plate

OPERATION

After proper installation, the operation of the HARTELL condensate pump is automatic. Water is collected in the reservoir and pumped out when the float raises to a pre-set point. As the water level goes down the float turns off the motor at another pre-set point. Under most circumstances the pump requires little maintenance for efficient operation. If a problem occurs, please refer to the maintenance instructions below.

MAINTENANCE

In normal applications, this pump requires no scheduled maintenance for efficient operation. However, to extend motor bearing life it is recommended that they be oiled every six months with S.A.E. 20. If a problem develops, the following guidelines can help to return the pump to service.

PUMP DOES NOT RUN

- Check to see that the power to the system (air conditioner and/or furnace) is on to allow production of condensate.
- Check that the pump is plugged in and the circuit is active (i.e. fuse or breaker not blown).
- Check the level of water in the reservoir; the level must be within 2" of the reservoir top to activate the switch. (The inlet tube may be blocked and require cleaning if no water is entering the reservoir).
- If there is a proper amount of water in the reservoir, the float may be stuck due to dirt or algae formation. (Flush the reservoir with warm water and a mild soap or detergent). See note below.

PUMP MOTOR RUNS WITH NO DISCHARGE

- Inspect the discharge tubing for its full length to make sure it is clear; make sure the tubing end is not plugged.
- Make sure the check valve is not clogged. (If clogged, UNPLUG THE PUMP; remove the fitting and clean with mild soap or detergent). See note below.
- The discharge port of the impeller chamber may be clogged due to an accumulation of debris. (See instructions below on how to disassemble unit and clean chamber).

NOTE: In case of extreme algae formation, UNPLUG THE PUMP, and fill the reservoir with a commercially available algicide. Follow directions for destroying the algae. After the proper waiting period DUMP the algicide out of the reservoir. Rinse with water, repeat if necessary. Be careful not to clog the check valve when starting the pump after this thorough cleaning.

DISASSEMBLY

1. Turn off power supply at fuse box and then drain water from reservoir.
2. Remove the four switch plate screws and carefully remove the switch/float assembly from the reservoir.
3. Remove the three impeller cover plate screws and loosen impeller cover plate.
4. Remove the four reservoir cover plate screws and remove the motor/cover assembly.
5. Remove all debris from inside the reservoir and wipe with damp cloth.

REASSEMBLY

Apply a small amount of gasket sealer (e.g., Silicone, Permatex, etc.) around the impeller chamber and reassemble by reversing the above procedure. Restore power to the unit and check operation.

*Hartell's Model A2-X-1965 DV has been tested to, and yielded results that fell within the acceptance criteria of UL Standard 2043, Third Edition, "Fire Test for Heat and Visible Smoke Release for Discrete Products and Their Accessories Installed in Air-Handling Spaces."

Keep these instructions with the pump. They may be valuable if service is needed under the terms of the warranty.

Model # _____ Date Code: _____
 Date of Installation: _____ Dealer: _____
 Installer: _____

