



INSTALLATION INSTRUCTIONS

REPLACEMENT COMBUSTION CHAMBER KIT FOR Bard Oil Fired Furnace

Lynn Manufacturing, Inc
15 Marion St., Lynn, MA 01905
TEL:781-593-2500 FAX:781-596-0430

1131

For Models:
DC36C, D48C, D60C
F81, F86CF, F86H, F97, F100CF
FCO85, FH085, FH110
FLF085, FLF110, FLR085, FLR110

WARNING This product contains fiberglass wool and ceramic fiber materials. Airborne fibers from these materials have been listed by the state of California as a possible cause of cancer through inhalation. Apply special care when handling these materials. (Burner door refractory, rear refractory, blankets, rope seal, jacket insulation, etc.)
Please see MSDS for more health and safety information.

BEFORE STARTING: **WARNING** Failure to perform the following can cause severe personal injury, death or substantial property damage!

- * Read all instructions before starting.
- * Follow all instructions in proper order.
- * Turn off service switch on boiler and all other electrical disconnect switches.
- * Close fuel supply valve(s) and disconnect fuel line from burner.

Installation Note: Some of the smaller model furnaces may require the combustion to be cut into two parts for installation. If necessary, the cuts should be made vertically on the sides of the chamber. (see drawing below)
After placing the chamber in position, use the stainless steel straps and hardware provided to secure the chamber back together.
Use of the straps is not required, if the chamber does not have to be cut for installation.

Bard Burner / Combustion Chamber Mounting System

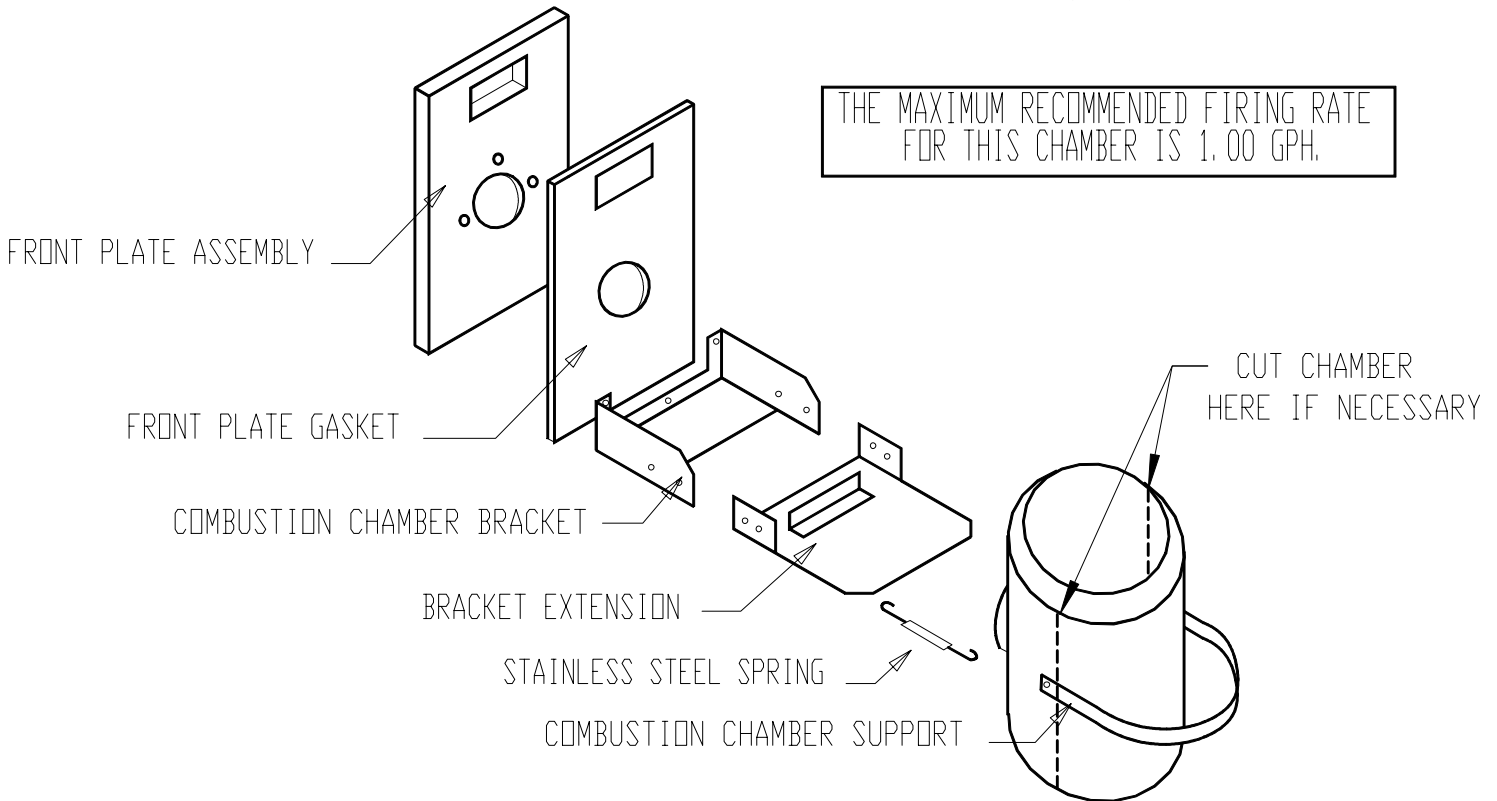

Fire furnace for 15 minutes to allow chamber to "cure".
NOTE: When first fired some smoke and a slight odor may occur. This is part of the curing process.
Combustion tests **MUST** be performed after the curing process is complete to insure proper performance.