



# INSTALLATION INSTRUCTIONS

REPLACEMENT COMBUSTION CHAMBER KIT FOR  
**Williamson**  
OWB, OWT, OSB & OST  
Oil Fired Boiler  
Fits all sizes

Lynn Manufacturing, Inc  
15 Marion St., Lynn, MA 01905  
TEL:781-593-2500 FAX:781-596-0430

# 1126

**WARNING** This product contains fiberglass wool and ceramic fiber materials. Airborne fibers from these materials have been listed by the state of California as a possible cause of cancer through inhalation. Apply special care when handling these materials. (Burner door refractory, rear refractory, blankets, rope seal, jacket insulation, etc.)  
**Please see MSDS for more health and safety information.**

**BEFORE STARTING:** **WARNING** Failure to perform the following can cause severe personal injury, death or substantial property damage!

- \* Read all instructions before starting.
- \* Follow all instructions in proper order.
- \* Turn off service switch on boiler and all other electrical disconnect switches.
- \* Close fuel supply valve(s) and disconnect fuel line from burner.

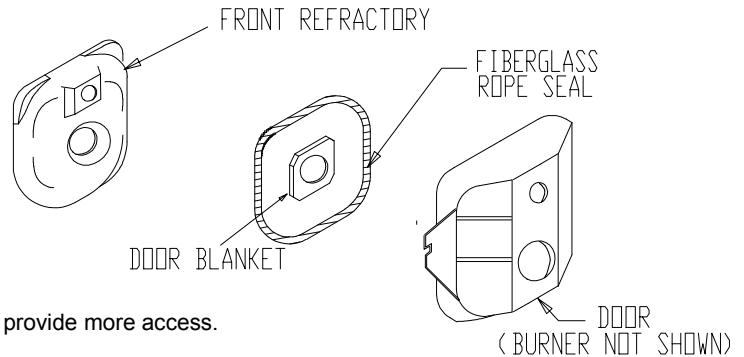
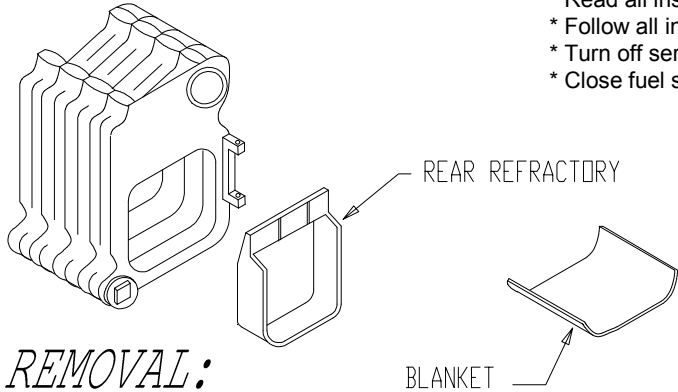

## REMOVAL:

1. Turn off service switch on boiler and all other electrical switches.
2. Turn off fuel supply valve (s) and disconnect fuel line from burner.
3. Disconnect burner wiring harness.
4. Remove nut holding door and swing open. Door can be lifted off hinge to provide more access.
5. Remove old front refractory and door blanket from door.
6. Remove old sealing rope from door perimeter.
7. Remove old blanket from combustion chamber floor.
8. Remove old rear refractory.
9. Wire brush all internal surfaces to remove scale, deposits, and old refractory and blanket material.
10. Clean interior door surfaces carefully, including rope seal groove.

## INSTALLATION:

1. Install the rear refractory as shown in the illustration, making sure it is flush against the rear wall and the upper lip is in the slot at the top. NOTE: Use the Kaowool paper shims provided between the rear refractory and boiler sides to insure a press fit if necessary.
2. Cover the floor of the combustion chamber with waterglass.
3. Place the 16" wide back edge of the blanket against the bottom lip of the rear refractory and the press the blanket down onto the floor of the boiler. Item #1072 is supplied with a 24" x 16" and #1148 with a 26-3/8" x 16".
4. Cut off the excess blanket to match the number of boiler sections as shown. The blanket must cover the entire bottom of the chamber area.
5. Install the door blanket over the burner tube.
6. Carefully press the front refractory into place in the door. To avoid breakage, work it into place gradually by pressing around the outer edge of the refractory. When refractory is properly seated, the end of the burner tube should be flush to 1/4" back from the inside surface of the refractory opening. **SEE ILLUSTRATION.**
7. Remove the paper backing from the rope adhesive by stretching the rope to break the paper and create a starting point. Then, press the rope into the cleaned groove. Install rope seal so ends meet at the bottom of the door and rope ends overlap.
8. Close burner door and secure gas-tight with nut. **WARNING** Maintain gas-tight seal around door to avoid severe personal injury or death.
9. Connect burner wiring harness.
10. Connect fuel line to burner. Turn on fuel supply valve (s).
11. Turn on service switch on boiler and any other electrical disconnect switches.
13. Fire burner for 15 minutes to allow chamber to "cure". NOTE: When first fired, some smoke and a slight odor may occur. This is part of the curing process.
14. Combustion test **MUST** be performed after the curing process is complete to insure proper performance.

