



# JB INDUSTRIES PRODUCT CATALOG

VERSION 48



# MADE IN USA



**HARDI**  
PREMIER MEMBER 2016 ★ ★ ★



A decade ago, JB Industries was relaunched with new ownership. My partner and I were excited to have acquired an established company with a great brand, loyal employees, and an outstanding reputation in the HVAC/R industry for manufacturing quality products. Our goal was to build on its legacy and to make JB even better. We started by setting some lofty goals including relaunching the company and brand, expanding our product portfolio, focusing on our customer base, updating and increasing our factory production capability, and instilling in our employees the absolute priority of customer satisfaction. We also adopted the slogan “Just Better” as a mindset for everything we do.

Now when we take a step back and review how we have done after ten years of operating and managing the company, we are pleased overall with what we see but there is still lots of opportunity to improve. Our engineering team added a number of products to our portfolio beginning with the Eliminator series vacuum pumps to our latest offerings including a new digital manifold, wireless micron gauge, and JB’s first refrigerant recovery machine. The leadership team made significant advances in expanding our domestic and international customer base. We made major investments in factory machinery allowing JB to bring manufacturing capabilities in-house that were previously supplied by others, helping us control supply and quality. Every one of our employees is focused on product quality and customer service.

We operate in a very challenging market driven by very determined competitors that keep raising the bar for excellence. This motivates the JB family to keep improving in an effort to maintain JB as the premium supplier of products for the HVAC/R industry. We have added highly talented personnel in key areas such as sales, marketing, engineering, and manufacturing to help keep JB resources and efforts optimized.

Of course, none of what we do at JB has any meaning without our loyal employees, representative and distributor organizations, and the customers they serve. We are indebted to them all for their support and feedback so vital to keeping JB innovative and productive.

Finally, as we begin our second decade of JB ownership, we commit to you that with your assistance we will continue to improve and increase our product offering, focus on our core advantage of being a U.S. manufacturer, stress customer satisfaction as our top priority and look forward to working together not only for the next decade but many decades to our mutual benefit. Thanks for a great 2015 and all the best for a healthy and prosperous 2016.

Jeff Cherif  
*President*

# NEW PRODUCTS



**F6 DUAL PISTON REFRIGERANT RECOVERY UNIT**

PAGE 14-15



**2-VALVE DIGITAL MANIFOLD**

PAGE 38-39



**LDC-4000 COMBUSTIBLE GAS LEAK DETECTOR**

PAGE 21



**IMPERIAL TORQUE WRENCH KIT**

PAGE 27, 64



## INDIVIDUAL QC TEST GAUGES

PAGE 43

R-22

R-134a

R-404A

## BACK-LIT LED GAUGES

PAGE 43

R-22

R-404A

R-410A



## JB-TOOLBAG 1

PAGE 27



## JB-BACKPACK 1

PAGE 27

# TABLE OF CONTENTS



## DEEP VACUUM

Platinum® Pumps ..... 8-9  
 Eliminator® Pumps ..... 10-11  
 Vacuum Pump Accessories ..... 12-13



## REFRIGERANT RECOVERY ..... 14-15



## ELECTRONIC INSTRUMENTS

Micron Gauges ..... 16-19  
 Refrigerant & Combustible Gas Leak Detectors ..... 20-23  
 Atlas Charging Scale ..... 24-25



## MINI SPLIT TOOL KIT ..... 26-27



## MANIFOLDS

Patriot™ 2-Valve Manifold ..... 28-29  
 M2 Standard Brass Manifold ..... 30-31  
 Zeppelin® 2-Valve Manifold ..... 32-33  
 Zeppelin® 3/8" Bore 4-Valve Manifold ..... 34-35  
 Revolver® 4-Valve Ball Valve Manifold ..... 36-37  
 Digital Manifold ..... 38-39  
 M2-Heat Pump Manifold ..... 40  
 Metric Manifolds ..... 41



## GAUGES

2-1/2" Metal ..... 42  
 3-1/8" Illuminating ..... 42  
 R-410A Only ..... 42  
 1% Illuminating Camo Pattern ..... 42  
 Metric ..... 42  
 LED Back-Lit ..... 43  
 Individual Test ..... 43  
 Class One (1%) Calibrated Illuminating & Liquid Filled ..... 43  
 Gauge Boots ..... 43  
 Gauge Accessories ..... 43



DEEP VACUUM  
REFRIGERANT RECOVERY  
ELECTRONIC INSTRUMENTS  
MINI SPLIT TOOL KIT  
MANIFOLDS  
GAUGES  
HOSES  
ACCESS VALVES  
TOOLS & ACCESSORIES  
BRASS FITTINGS  
REPAIR  
INDEX

## HOSES

Kobra® High Pressure Environmental Hose .....	44
CLS Series UL-Approved Secure Seal .....	45
CLE Series Charging .....	46
3/8" & 1/2" Evacuation Hose .....	47
Black Charging Hose .....	48
Deep Vacuum Flexible Metal Hose .....	48
1/4" Standard Charging Hose .....	48
Secure Seal Rebuild Kit .....	49



## ACCESS VALVES

Shield® Refrigerant Locking Caps .....	50-51
JB Industries Access Valves .....	52
Copper Tube Extensions .....	53
Swivel Flare Connections .....	54
MPT Connections .....	55
Bulk Fittings .....	56
Valve Cores & Removal Tools .....	57
O-Ring Seal Caps .....	58
Quick Couplers .....	59
Ball Valve Actuators .....	60-61

## TOOLS & ACCESSORIES

Rothenberger Tools .....	62
Tube Cutters .....	62
Pliers .....	63
Deburring Tools .....	63
Tube Benders .....	63-64
Flaring Tools .....	65
Swage .....	65-66
Torque Wrenches .....	64
Capillary Tubing .....	68-69
Automotive .....	70
La-Co Products .....	71



## BRASS FITTINGS

Flared Tube Fittings .....	72
Assembly Instructions .....	72
Brass Pipe Fittings .....	73-77

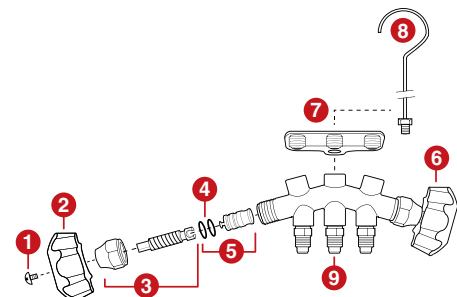

<b>REPAIR</b> .....	<b>78-85</b>
---------------------	--------------

<b>INDEX</b> .....	<b>86-91</b>
--------------------	--------------

# PLATINUM®

**1/4", 3/8" & 1/2"  
INTAKE TEE**

ERGONOMIC 1/2"  
BREAK RESISTANT,  
EXHAUST HANDLE  
WITH LIFT RING

**BLANK-OFF/  
ISOLATION VALVE  
FOR TESTING  
SYSTEM LEAKS**

GAS BALLAST  
KEEPS OIL  
CLEANER TO  
EXTEND PUMP LIFE

**ALL METAL  
CONSTRUCTION  
BRASS FITTINGS  
& STAINLESS  
STEEL VALVING**

2-STAGE DIRECT  
DRIVE TO ACHIEVE  
DEEP VACUUM

**CHECK VALVE  
PREVENTS OIL  
BACK FLOW**

TETHERED SAFETY  
CAP PREVENTS  
OIL SPILLS

**O-RING SEALED  
DRAIN VALVE  
PREVENTS LEAKS**

THERMAL  
OVERLOAD  
PROTECTION

**LOW PROFILE  
ROCKER POWER  
SWITCH**

**WARRANTY**

24 MONTHS  
OTC

**100%**

FIELD  
REPAIRABLE

**15 MICRONS**

VACUUM  
RATING

**2-STAGE**

DIRECT DRIVE

**100%**

FACTORY TESTED



**1/2 HP CAPACITOR START**

**ALUMINUM FINS FOR SUPERIOR HEAT DISSIPATION**

**ALL METAL CONSTRUCTION INCLUDING BRASS FITTINGS AND STAINLESS STEEL VALVING**

**CHECK VALVE PREVENTS OIL BACK FLOW DURING POWER FAILURE**

**AVAILABLE IN 115V DOMESTIC & 230V INTERNATIONAL VOLTAGES**



*Completely field repairable, our Platinum® series is designed to last.  
Turn to page 81 for a complete list of repair parts. Subject to warranty as set forth on page 78.  
Warranty Terms & Conditions of sales set forth at [www.jbind.com](http://www.jbind.com).*

*To check vacuum accurately, use the DV-40 SUPERNOVA, DV-40S or the DV-22N.  
Operating instructions available on our web site at [www.jbind.com](http://www.jbind.com).*



# THE BEST VACUUM PUMP IN THE INDUSTRY DESIGNED FOR THE SERIOUS AIR CONDITIONING & REFRIGERATION TECHNICIAN

## AMERICAN PRIDE & EXPERTISE

### BACKED BY AN UNPRECEDENTED 24 MONTH OVER-THE-COUNTER WARRANTY

American made and subjected to JB's rigorous performance standards, the Platinum® series is the top of the line for both quality and durability.

The Platinum® vacuum pump features a gas ballast and blank off valve. Each Platinum® vacuum pump is manufactured at JB's facility in Aurora, Illinois. All pumps are 100% tested before they receive the JB stamp of approval. Quality and dependability are woven in with hard working American pride.



PLATINUM® PUMPS					
	DV-42N	DV-85N	DV-142N	DV-200N	DV-285N
<b>CFM</b>	1.5 CFM (42 l/m)	3 CFM (85 l/m)	5 CFM (142 l/m)	7 CFM (200 l/m)	10 CFM (285 l/m)
<b>MOTOR</b>	1/2 HP, 1725 RPM	1/2 HP, 1725 RPM	1/2 HP, 1725 RPM	1/2 HP, 1725 RPM	1/2 HP, 1725 RPM
<b>VOLTAGE</b>	115v, 60Hz	115v, 60Hz	115v, 60Hz	115v, 60Hz	115v, 60Hz
<b>PLUG</b>	Std. US 110v	Std. US 110v	Std. US 110v	Std. US 110v	Std. US 110v
<b>INTAKE PORT</b>	1/4"	1/4" x 3/8"	1/2" x 1/4" x 3/8"	1/2" x 1/4" x 3/8"	1/2" x 1/4" x 3/8"
<b>OIL CAP</b>	26 oz (798 cc)	26 oz (798 cc)	21 oz (680)	21 oz (680)	26 oz (798 cc)
<b>SHIP DIMENSIONS</b>	17-5/8" h 9-1/8" w 14" l	17-5/8" h 9-1/8" w 14" l	17-5/8" h 9-1/8" w 14" l	17-5/8" h 9-1/8" w 14" l	17-5/8" h 9-1/8" w 14" l
<b>WEIGHT</b>	29 lbs (13.2 kg)	30 lbs (13.6 kg)	32 lbs (14.5 kg)	32 lbs (14.5 kg)	34 lbs (15.4 kg)

DUAL VOLTAGE* <span style="float: right;">-250</span>					
	DV-42N-250	DV-85N-250	DV-142N-250	DV-200N-250	DV-285N-250
<b>MOTOR</b>	1/2 HP, 1725 (1425) RPM	1/2 HP, 1725 (1425) RPM	1/2 HP, 1725 (1425) RPM	1/2 HP, 1725 (1425) RPM	1/2 HP, 1725 (1425) RPM
<b>VOLTAGE</b>	115v, 60Hz & 230v/50Hz	115v, 60Hz & 230v/50Hz	115v, 60Hz & 230v/50Hz	115v, 60Hz & 230v/50Hz	115v, 60Hz & 230v/50Hz
<b>PLUG</b>	Std. US 220v	Std. US 220v	Std. US 220v	Std. US 220v	Std. US 220v

EUROPEAN* <span style="float: right;">-250EU</span>					
	DV-42N-250EU	DV-85N-250EU	DV-142N-250EU	DV-200N-250EU	DV-285N-250EU
<b>MOTOR</b>	1/2 HP, 1425 RPM	1/2 HP, 1425 RPM	1/2 HP, 1425 RPM	1/2 HP, 1425 RPM	1/2 HP, 1425 RPM
<b>VOLTAGE</b>	230v/50Hz	230v/50Hz	230v/50Hz	230v/50Hz	230v/50Hz
<b>PLUG</b>	European	European	European	European	European

UNITED KINGDOM* <span style="float: right;">-250UK</span>					
	DV-42N-250UK	DV-85N-250UK	DV-142N-250UK	DV-200N-250UK	DV-285N-250UK
<b>MOTOR</b>	1/2 HP, 1425 RPM	1/2 HP, 1425 RPM	1/2 HP, 1425 RPM	1/2 HP, 1425 RPM	1/2 HP, 1425 RPM
<b>VOLTAGE</b>	230v/50Hz	230v/50Hz	230v/50Hz	230v/50Hz	230v/50Hz
<b>PLUG</b>	UK	UK	UK	UK	UK

# ELIMINATOR®

**1/4" & 3/8"  
INTAKE TEE**

ERGONOMIC 1/2"  
BREAK RESISTANT,  
EXHAUST HANDLE

**LARGE, EASY TO  
SEE OIL LEVEL  
SIGHT GLASS**

2-STAGE DIRECT  
DRIVE TO ACHIEVE  
DEEP VACUUM

**OIL FILL LOCATED  
ON COVER FOR  
EASY ACCESS**

INTAKE TEE  
SPACED AWAY  
FROM HANDLE FOR  
ACCESSIBILITY

**TETHERED SAFETY  
CAP PREVENTS  
OIL SPILLS**

WELL PROTECTED  
DRAIN VALVE

**O-RING SEALED TO  
PREVENT LEAKS**

**WARRANTY**

24 MONTHS  
OTC

**100%**

FIELD  
REPAIRABLE

**25 MICRONS**

VACUUM  
RATING

**2-STAGE**

DIRECT DRIVE

**100%**

FACTORY TESTED



**1/2 HP CAPACITOR START**

**ALL METAL CONSTRUCTION INCLUDING BRASS FITTINGS & STAINLESS STEEL VALVING**

**INCREASED OIL CAPACITY FOR COOLER RUNNING TEMPERATURE  
& REDUCED CONTAMINATION**

**AVAILABLE IN 115V DOMESTIC & 230V INTERNATIONAL VOLTAGES**

*Completely field repairable, our Eliminator® series is designed to last.  
Turn to page 82 for a complete list of repair parts. Subject to warranty as set forth on page 78.  
Warranty Terms & Conditions of sales set forth at [www.jbind.com](http://www.jbind.com).*

*To check vacuum accurately, use the DV-40 SUPERNOVA, DV-40S or the DV-22N.  
Operating instructions available on our web site at [www.jbind.com](http://www.jbind.com).*

# THE BEST AMERICAN MADE ECONOMY PUMP

## BACKED BY AN UNPRECEDENTED 24 MONTH OVER-THE-COUNTER WARRANTY

Built for the air conditioning serviceman who wants a high quality, dependable vacuum pump, the ELIMINATOR® series offers many higher end features with an affordable price. American made & 100% tested to JB's stringent quality standards, the ELIMINATOR® is the best economy vacuum pump in the industry.

ELIMINATOR® PUMPS			
	DV-3E	DV-4E	DV-6E
<b>CFM</b>	3 CFM (85 l/m)	4 CFM (113 l/m)	6 CFM (170 l/m)
<b>MOTOR</b>	1/2 HP, 1725 RPM	1/2 HP, 1725 RPM	1/2 HP, 1725 RPM
<b>VOLTAGE</b>	115v, 60Hz	115v, 60Hz	115v, 60Hz
<b>PLUG</b>	Std. US 110v	Std. US 110v	Std. US 110v
<b>INTAKE PORT</b>	1/4" x 3/8"	1/4" x 3/8"	1/4" x 3/8"
<b>OIL CAP</b>	28 oz (828 cc)	25 oz (739 cc)	25 oz (739 cc)
<b>SHIP DIMENSIONS</b>	17-5/8" h 9-1/8" w 14" l	17-5/8" h 9-1/8" w 14" l	17-5/8" h 9-1/8" w 14" l
<b>WEIGHT</b>	29 lbs (13.2 kg)	30 lbs (13.6 kg)	30 lbs (13.6 kg)

DUAL VOLTAGE*			-250
	DV-3E-250	DV-4E-250	DV-6E-250
<b>MOTOR</b>	1/2 HP, 1725 (1425) RPM	1/2 HP, 1725 (1425) RPM	1/2 HP, 1725 (1425) RPM
<b>VOLTAGE</b>	Std. US 110v	Std. US 110v	Std. US 110v
<b>PLUG</b>	1/4" x 3/8"	1/4" x 3/8"	1/4" x 3/8"

EUROPEAN*			-250EU
	DV-3E-250EU	DV-4E-250EU	DV-6E-250EU
<b>MOTOR</b>	1/2 HP, 1425 RPM	1/2 HP, 1425 RPM	1/2 HP, 1425 RPM
<b>VOLTAGE</b>	230v/50Hz	230v/50Hz	230v/50Hz
<b>PLUG</b>	European	European	European

UNITED KINGDOM*			-250UK
	DV-3E-250UK	DV-4E-250UK	DV-6E-250UK
<b>MOTOR</b>	1/2 HP, 1425 RPM	1/2 HP, 1425 RPM	1/2 HP, 1425 RPM
<b>VOLTAGE</b>	230v/50Hz	230v/50Hz	230v/50Hz
<b>PLUG</b>	UK	UK	UK

### CHOOSING CFM

CFM<sup>2</sup> = Maximum Tonnage Rating. Therefore, take the CFM rating of a pump and multiply it by that number to find the maximum number of tons the pump is rated for:

**3 CFM PUMP (3 X 3) IS RATED FOR 9 TONS.**

**A 7 CFM PUMP (7 X 7) IS RATED FOR 49 TONS.**

In many cases, depending on the system line sizes of large tonnage systems, it is better to put two or more smaller, easily maneuverable pumps at different locations. This will overcome some of the pressure drop problems and evacuate faster than a single, large pump. Pumps in the 1.5 to 10 CFM class are adequate to handle 99% of the work.

### OUR PUMPS ARE BUILT TO LAST. TO LEARN HOW TO PROPERLY CARE FOR YOUR PUMP VISIT OUR WEBSITE.



THE LAST INCH OF PRESSURE AS INDICATED ON THE GAUGE IS 25,400 MICRONS.



**DV-22N**  
DIGITAL MICRON GAUGE

### HOW TO MEASURE EVACUATION

A micron is a unit of pressure starting from a perfect vacuum (no pressure) expressed in linear increments. One inch equals 25,400 microns. That last inch of pressure below zero on the low side compound gauge (see illustration) is 25,400 microns.

A compound gauge only indicates that a vacuum is being produced, but does not tell you if moisture or contaminants are still in the system. Evacuation is complete when a system holds 500 microns to ensure dehydration is complete.

Therefore, there is a small fraction of an inch difference between a complete evacuation and an inadequately evacuated system. A compound gauge cannot measure this pressure at these levels accurately.

Only a micron gauge like the SUPERNOVA DV-40 or our DV-22N (refer to page 19) can accurately read the low pressures produced when evacuation/dehydration is complete.

# DEEP VACUUM ACCESSORIES

## THE TANK DV-T1 VACUUM PUMP OIL CADDY

All vacuum pumps require changing oil after every use. Contaminated oil, laden with moisture and acid, will damage pumps and shorten pump life. On top of that, deep vacuums cannot be achieved with contaminated oil. Maintaining clean oil in the pump ensures that your pump will operate at peak efficiency.

- CHANGE YOUR VACUUM PUMP OIL IN BETWEEN JOBS
- NO MORE MESS AND SPILLS. EASY, CONVENIENT, AND PORTABLE
- EXTENDS THE LIFE OF YOUR VACUUM PUMP



## BLACK GOLD BEST OIL IN THE INDUSTRY

Black Gold Vacuum Pump Oil is the gold standard in vacuum pump care. For use in any vacuum pump, Black Gold is extremely pure and non-detergent. Our Black Gold is hydro processed which means it goes through a series of catalytic steps rendering the oil extremely refined, more viscous, and more stable. The result is clear mineral oil which will alert you to contamination sooner as it becomes cloudy or milky. In extreme temperatures, the oil will be more resistant to contaminants. We still recommend, however, that the oil be changed after every evacuation for maximum performance and pump efficiency.

The best test to see if your oil is contaminated is through a micron gauge. With a leak-free system, if your DV-22N micron gauge is still not reading a deep vacuum, the oil is too contaminated and should be changed. If the micron gauge pulls down to about 50 microns the oil is good. Viscosity is a measure of the weight of the oil. For industrial oil, the viscosity is an ISO grading at 40°C. Black Gold vacuum pump oil is an ISO 41, special to this type of application. Sold in case quantity.



*PUMP OIL ACTS,  
SIMULTANEOUSLY, AS A  
COOLANT, LUBRICANT  
& SEALANT*

### BLACK GOLD VACUUM PUMP OIL

PART NO.	DESCRIPTION	QTY.	SHIP. WEIGHT	DIMENSIONS
DVO-1	Pint Bottle	24	25 lbs / 11.4 kg	9" x 14-1/4" x 12-1/2"
DVO-12	Quart Bottle	12	24 lbs / 10.9 kg	11" x 13" x 10"
DVO-24	Gallon Bottle	6	47 lbs / 21.4 kg	12 - 1/2" x 15-1/2" x 12-1/2"

# 100% AMERICAN MADE

## OIL MIST FILTER

Eliminates oil mist from pump handle. DV-F8 fits 1/2" exhaust pipe in 2008+ model Platinums® and 2011+ Eliminators®, while DV-F6 fits 3/8" exhaust pipe for all pre-2011 Eliminator® series and pre-2008 model Platinums®.



**DV-F8**  
1/2" OIL MIST FILTER

## OIL MIST FILTER

PART NO.	DESCRIPTION
DV-F6	Oil mist filter 3/8"
DV-F8	Oil mist filter 1/2"

## SWIVEL COUPLERS

Features an O-ring Seal.



**D10244**  
1/4" FEMALE SWIVEL COUPLER

## SWIVEL COUPLERS

D10244	1/4" Female swivel coupler
D10266	3/8" Female swivel coupler
P90009	1/4" Replacement O-ring (10 pack)
P90012	3/8" Replacement O-ring (10 pack)

## SHUT OFF VALVE

Our O-ring quick coupler valves are great for blanking off any vacuum system and works for pressures up to 800 lbs.



**D10162**  
1/4" SHUT OFF VALVE

## SHUT OFF VALVE

D10162	1/4" Female QC x 1/4" flare
--------	-----------------------------

## QUICK COUPLERS

Features an O-ring seal and no depressor. Please refer to page 59 for a complete list of elbow, straight, and Female NPT thread couplers and valves.

**QC-E64**  
3/8" QC X 1/4" SAE ELBOW QUICK COUPLER



## QUICK COUPLERS

QC-E64	3/8" QC x 1/4" SAE elbow
QC-S64	3/8" QC x 1/4" SAE straight
P90009	1/4" Replacement O-ring (10 pack)
P90012	3/8" Replacement O-ring (10 pack)

# DV-29 MICRON HOOK UP TEST UNIT

USED IN CONJUNCTION WITH JB'S DIGITAL MICRON GAUGE & THE DV-29 ENSURES A LEAK-PROOF SETUP.

## DV-29 CONSISTS OF ONE OF EACH OF THE FOLLOWING:

- DV-291
- DV-292
- DV-293
- DV-294
- DV-295

When used with our micron gauges DV-40S, DV-40, or DV-22N, the DV-29 ensures a leak-proof setup. JB's DV-29 works with all micron gauges and creates a closed system, eliminating any leakage under deep vacuum.

The DV-29 eliminates other problems when attaching the micron gauge into the system. If the micron gauge is attached directly to the vacuum pump or with a 3' (91.4 cm) dedicated hose, you will get a lower reading as the gauge is sensing what the pump is doing and not what the pump is doing to the system.

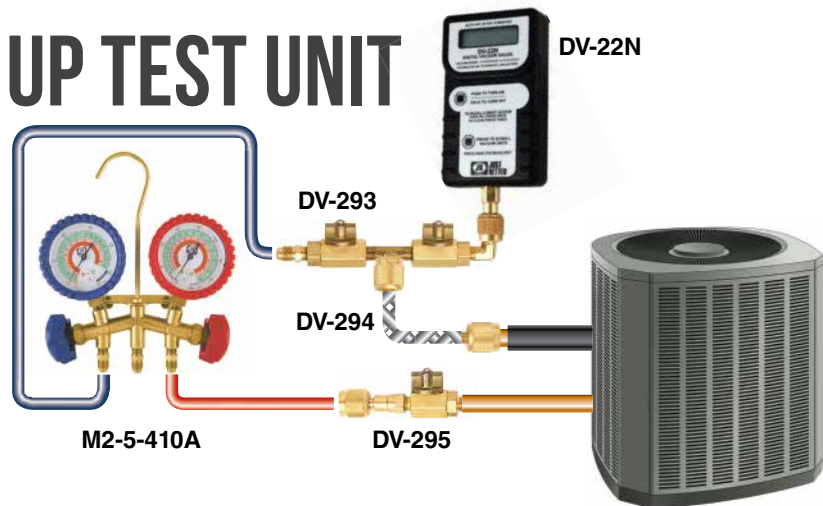

## DV-29 MICRON HOOKUP TEST UNIT

PART NO.	DESCRIPTION
DV-29	Leak-proof micron hook up test kit, which includes: DV-292, DV-293, DV-294, and DV-295
DV-291	Replacement 1/4" SAE swivel coupler
DV-292	Replacement 90° male flare with 1/4" O-ring QC
DV-293	Replacement valve assembly 1/4" MFL connector
DV-294	Replacement 10" (25.4 cm) metal hose with O-ring
DV-295	Replacement ball valve with O-ring QC and depressor
P90009	Replacement O-ring (10 pack)



DV-291



DV-292



P90009



# DUAL PISTON REFRIGERANT RECOVERY UNIT

**MICRO CHANNEL CONDENSER FOR INDUSTRY LEADING RECOVERY RATES**

POWERFUL DUAL PISTON COMPRESSOR

**THREE YEAR OVER-THE-COUNTER WARRANTY**

FULL ONE HORSEPOWER MOTOR

**OVER-SIZED COOLING FAN FOR SUPERIOR HEAT DISSIPATION**

CAN SELF-PURGE WITHOUT CHANGING HOSES

**HEAVY DUTY HANDLE WITH COMFORTABLE RUBBER GRIP**

SIMPLE TWO-VALVE OPERATION

**INCLUDES SHOULDER STRAP, FILTER/DRIER, & POWER CORD**

**COMPRESSOR**  
DUAL PISTON

**MOTOR**  
FULL ONE HORSE POWER

**CONDENSER**  
MICRO-CHANNEL FOR SUPERIOR COOLING

**WARRANTY**  
UNPRECEDENTED THREE YEAR OTC

## INDUSTRY LEADING REFRIGERANT RECOVERY

The new F6-DP Recovery Unit features a full 1 horsepower motor and is backed by an unsurpassed 3 year OTC warranty. The F6's dual piston compressor and high efficiency micro-channel condenser design recovers refrigerant at industry leading speeds.

**NEW**



## COMPETITOR COMPARISON CHART

	F6-DP	APPION G1	APPION G5 TWIN	CPS CR700	CPS TR21	CPS TR600	PROMAX / ROBINAIR RG 6000	PROMAX / ROBINAIR RG 3000	YELLOW JACKET LTE	
COMPRESSOR TYPE	Twin head, dual-valve poppet style	Single cylinder	Twin head, dual-valve horizontal poppet style	Dual-valve poppet style	Twin head, dual-valve in line poppet style	Twin head, dual valve in line style	Twin head, dual-valve horizontal poppet style	Single cylinder	Twin head, dual-valve horizontal poppet style	
CONDENSER TYPE	Micro channel condenser	Aluminum fin, copper tube	2 separate small Aluminum fin, copper tube	Aluminum fin, copper tube	None, have to buy separate	Aluminum fin, copper tube	Aluminum fin, copper tube	Aluminum fin, copper tube	Aluminum fin, copper tube	
MOTOR SIZE	1 HP	1/2 HP	1/2 HP	1 HP, AC	1 HP	2/3 HP	3/4 HP	1/3 HP	1/2 HP	
WARRANTY	3 year over the counter	1 year	1 year	1 year	1 year	1 year	1 year over the counter	1 year over the counter	1 year	
CIRCUIT BREAKER	Yes	No	No	Yes	No	No	Yes	No	Yes	
KNOB TYPE	Metal	None	Plastic	Plastic	No Manifold	Plastic	Plastic	Plastic	Metal	
SELF-PURGE	Yes	No	No	Yes	No	No	Yes	No	No-requires switching of hose	
FILTER PROVIDED	Yes	No	No	No	No	No	No	No	No	
SHOULDER CARRYING STRAP INCLUDED?	Yes	No	No	Yes	No	No	No	No	No	
DETACHABLE / REPLACEABLE POWER CORD?	Yes	No	No	Yes	Yes	No	Yes	Yes	No	
EPA CERTIFIED RATES / R22	UL	UL	UL	UL	UL	UL	UL	UL	UL	
R-22	PUSH / PULL LIQUID RECOVERY RATE	11.00 (4.99)	10.80 (4.90)	16.62 (7.54)	15.80 (7.17)	31.43 (14.30)	Not Listed	14.52 (6.59)	11.86 (5.37)	9.17 (4.16)
	LIQUID RECOVERY RATE	5.97 (2.71)	8.55 (3.88)	6.21 (2.82)	6.86 (3.11)	8.86 (4.02)	Not Listed	9.43 (4.28)	6.39 (2.90)	6.83 (3.10)
	VAPOR RECOVERY RATE	0.53 (0.24)	0.26 (0.12)	0.62 (0.28)	0.49 (0.22)	0.59 (0.27)	Not Listed	0.53 (0.24)	0.20 (0.09)	0.37 (0.17)
	HIGH TEMP VAPOR RECOVERY RATE	0.62 (0.28)	0.31 (0.14)	0.42 (0.19)	Not Listed	0.86 (0.39)	0.86 (0.39)	0.46 (0.21)	0.22 (0.10)	Not Listed

Rates lb./min (kg/min)

### F6-DP DUAL PISTON REFRIGERANT RECOVERY UNIT

PART NO.	DESCRIPTION
F6-DP	F6 Refrigerant recovery unit
F6-FLT	Filter attachment
F6-STRAP	Replacement carrying strap
F6-BH	Replacement blue knob and screw
F6-RH	Replacement red knob and screw
F6-110-CRD	Replacement power cord
F6-RBFT	Replacement rubber foot
F6-RHP	Replacement gauges
REC-TANK	Empty refrigerant tank cylinder

# DV-40S

## WIRELESS MICRON GAUGE

**FACTORY CALIBRATION  
ACCURATE VACUUM  
RANGE 12,000  
MICRONS TO 10  
MICRONS**

**BACKUP DISPLAY ON  
THE GAUGE**

**HEAVY DUTY WATER  
RESISTANT**

**RECHARGEABLE  
BATTERY**

**USB CHARGING  
ADAPTER FOR WALL  
OR COMPUTER  
CHARGING**

### WARRANTY

12 MONTHS

### UNITS OF MEASURE

MICRONS, PSIA, INHG, PASCALS, TORR,  
MTORR, & MBAR

### BLUETOOTH 4.0



WIRELESS  
CONNECTIVITY

## FREEDOM ON THE JOB

The DV-40S Wireless Micron Gauge puts the power in your hands with data logging capabilities, programmable alarms, and wireless connection for IOS and Android smart devices through the new JB app.



YouTube

## FREE SMART DEVICE ACCESS THROUGH THE JB DV-40S APP

- REMOTE MANAGEMENT CAPABILITY
- PROGRAMMABLE ALARM SYSTEM FOR LOW/HIGH LIMITS AND APPROACHING/LEAKING
- DATA LOGGING SYSTEM FOR RECORDING & SHARING JOB STATISTICS
- LIGHT OR DARK APP THEME FOR VISIBILITY IN DIFFERENT LIGHTING ENVIRONMENTS

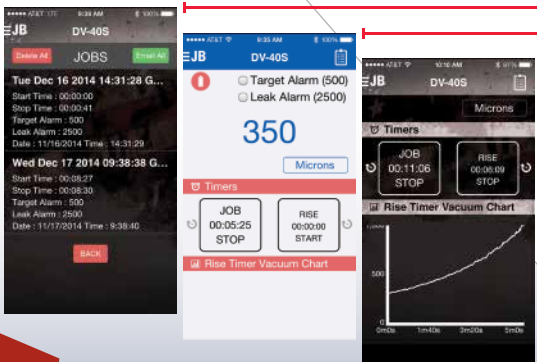

### DV-40S WIRELESS MICRON GAUGE

PART NO.	DESCRIPTION
DV-40S	Wireless micron gauge with case & charging adapter
DV-40S-CS	Protective carrying case for the DV-40S
DV-40S-AC	Charging adapter with cord
A34000D	1/4" QC x 1/4" access tee (with depressor)
P90009	Replacement O-ring (10 pack)



# FREE JB DV-40S APP



## THE JB DV-40S APP

Access the advanced features of the DV-40S wireless micron gauge with the touch of the screen. Features include remote management, programmable alarms & data logging.

- 1 *Main app menu button. All advanced features can be found here as well as color theme options & scanning for a DV-40S to connect to.*
- 2 *Clipboard button accesses the data logging and sharing features. Save data and email it as simple text.*
- 3 *Check boxes arm the target and leak alarms separately and can be silenced by unchecking them.*
- 4 *Main vacuum reading display.*
- 5 *Unit of measure selection.*
- 6 *Overall job and rise test timers can be managed and recorded separately.*
- 7 *The rise vacuum chart will give a line graph display of the change in vacuum during the rise test.*



AVAILABLE IN THE APPLE APP STORE  
AND GOOGLE PLAY FOR ANDROID AS "DV-40S"



# SUPERNOVA

## DV-41 DIGITAL MICRON GAUGE

**FULLY PROGRAMMABLE INCLUDING ALARM SETTINGS, SHUT-OFF & BACKLIGHT DURATION**

LARGE, EASY TO READ LCD SCREEN

**FACTORY CALIBRATED AND REQUIRES NO ADDITIONAL CALIBRATION**

MEASURES IN MICRONS, PSIA, INHG, PASCALS, TORR, MTORR, AND MBAR

**ADJUSTIBLE ALARMS FREE YOU TO PERFORM OTHER TASKS**

SENSOR CONTAMINATION EASILY CLEANED WITH SIMPLE ALCOHOL

**BRASS FITTING ON LENGTHY FLEXIBLE CORD FOR HARD TO REACH PLACES**

POWERED BY THREE AA BATTERIES (INCLUDED) OR AC ADAPTER

### WARRANTY

12 MONTHS  
OTC

### FLEXIBLE SENSOR

BRASS FITTING ON A FLEXIBLE CORD FOR HARD TO REACH PLACES

### FACTORY CALIBRATED

ACCURATE VACUUM RANGE  
12,000 MICRONS TO 10 MICRONS

## INNOVATION AT ITS BEST

The Dealer Design Award winning SUPERNOVA® is accurate from 12,000 microns down to 10 microns. This customizable digital gauge allows a service technician to be certain when a system is properly evacuated of air and moisture.



DEALER DESIGN AWARDS  
the NEWS | BRONZE

## PROGRAMMABLE FEATURES:

**APPROACH ALARM & LEAK ALARM SETTINGS**

**ADJUSTIBLE AUTO-OFF TO CONSERVE BATTERY LIFE**

**PROGRAMMABLE BACKLIGHT DURATION**



### DV-41 DIGITAL MICRON GAUGE

PART NO.	DESCRIPTION
DV-40	Hand-held digital vacuum gauge
DV-41	DV-40 with protective carrying case and A/C adapter
DV-40C	Protective carrying case and adapter only
DV-40AC	A/C Adapter (NOT A BATTERY CHARGER)
DV-40HK	Replacement hanging hook
A34000D	1/4" QC x 1/4" access tee (with depressor)
P90009	Replacement O-ring (10 pack)

\*The DV-40 is not recommended for connection to vacuum pump when blanking off isolation valve. The preferred hook-up uses the DV-29 when the valve is engaged as illustrated on page 13.

# DV-22N

## DIGITAL MICRON GAUGE

ELECTRONIC  
INSTRUMENTS

### WARRANTY

12 MONTHS  
OTC

### UNITS OF MEASURE

MICRONS, PSIA, INHG, PASCALS,  
TORR, MTORR, & MBAR

### FACTORY CALIBRATION

ACCURATE VACUUM RANGE  
9,000 MICRONS TO 20 MICRONS

JB's DV-22N reads vacuum in 7 international units: Microns, PSIA, InHg, mBars, Pascals, Torr, and mTorr. The DV-22N has a micron range of 20 to 9,000 microns.

Attach the micron gauge to the vacuum pump before evacuation to make sure the pump pulls down to at least 50 microns. If it doesn't, your pump oil is contaminated and should be changed.

A compound gauge only indicates that a vacuum is being produced, but does not tell you if moisture and acids are still present in the system. Micron gauges are the only tool to accurately read the low pressure produced when evacuation/dehydration is complete. Refer to page 11 under "How to Measure Evacuation" for more information.

#### SAVES LAST VACUUM READOUT AFTER SHUT-DOWN

THE FEMALE CONNECTION ON THIS UNIT ALLOWS FOR DIRECT CONNECTION TO THE A/C UNIT WITHOUT NEED OF HOSE CONNECTION. JB DOES NOT RECOMMEND CONNECTION THROUGH A HOSE AS IT NEGATIVELY AFFECTS ACCURACY.

POWERS OFF AFTER 10 MINUTES OF NO USE TO PRESERVE BATTERY LIFE

+32°F TO 120°F (+0°C TO 48.9°C) AMBIENT TEMPERATURE

DV-24N GAUGE IS NOT NIST TRACEABLE, BUT CALIBRATED WITH NIST TRACEABLE GAUGES SUCH AS MKS BARATRONS

T2-4 FLARE TEE USED TO ATTACH HOSES TO GAUGE. SOLD AS AN ACCESSORY.

*\*The DV-22N is not recommended for connection to vacuum pump when blanking off isolation valve.*

*The preferred hook-up uses the DV-29 when the blank-off valve is engaged as illustrated on page 13.*



#### DV-22N DIGITAL MICRON GAUGE

PART NO.	DESCRIPTION
DV-22N	Hand-held digital vacuum gauge
DV-24N	DV-22N with protective carrying case
DV-26N	Protective carrying case only
DV-18	A/C Adapter
P90009	1/4" replacement O-ring (10 pack)
A34000D	1/4" QC x 1/4" access tee (w/ depressor)
T2-4	1/4" SAE flare tee

# PROWLER

## REFRIGERANT LEAK DETECTOR

**CERTIFIED TO ASHRAE  
STANDARD 173-2012**

SENSITIVITY CAN BE  
PROGRAMMED TO  
HIGH, MEDIUM, LOW

**PROPRIETARY  
ELECTROCHEMICAL  
SENSOR**

WARM UP TIME  
< 30 SECONDS &  
RESPONSE TIME IS  
IMMEDIATE

**MUTABLE AUDIO  
ALARM BACKED UP  
BY SILENT VIBRATING  
HANDLE ALARM**

BACKLIT LCD SCREEN  
TILTS UPWARD FOR  
EASY VIEWING AT  
ANY ANGLE

**17" FLEXIBLE PROBE**

SAFE TO USE IN  
COMBUSTIBLE  
ATMOSPHERES

**SENSOR LIFE  
GREATER THAN  
10 YEARS**

LEAK INDICATOR  
BAR GRAPH  
DISPLAYS LEAK  
INTENSITY

**WARRANTY**  
24 MONTHS

**10+ YEAR**  
SENSOR LIFE

**ALARM**  
AUDIBLE, VISUAL BAR GRAPH,  
& SILENT VIBRATING HANDLE

**NEW**  
MANUAL RESET

## LD-5000

### PROWLER REFRIGERANT LEAK DETECTOR

The Prowler features a new manual calibration mode & reset control. It's highly sensitive electrochemical sensor detects all **HFC, HCFC, & HFO** refrigerants, helping you find even the smallest of leaks

### CERTIFICATIONS INCLUDE:

**CE, ASHRAE 173-2012, EN 14624:2012,  
SAE J2791, & SAE J2913**

\*R1234yf is a low GWP alternative HFO refrigerant for HFC & HCFC refrigerants that are currently being phased out by the U.S. EPA. It is an A2L flammable refrigerant as defined by ASHRAE 34

**ELECTROCHEMICAL FUNCTION OF SENSOR  
DOES NOT DIMINISH OVER TIME OR WITH USE**

**SENSOR LIFE TESTED TO BE GREATER  
THAN 10 YEARS, UNIQUE IN INDUSTRY**

**PROGRAMMABLE SENSITIVITY TO  
HIGH, MEDIUM, LOW**

**SAFE TO USE IN COMBUSTIBLE  
ATMOSPHERES**

**LOW BATTERY CONSUMPTION AND  
EXCELLENT CIRCUIT STABILITY**



YouTube

- 1 Adjustable back-lit display
- 2 Leak intensity bar graph
- 3 Vibrating leak alarm handle for silent feedback

LD-5000	
PART NO.	DESCRIPTION
LD-5000	Prowler leak detector in case
LD-S100	Replacement sensor (3 prong)
LD-S101	Replacement sensor (6 prong)
LD-RF5	Replacement filters (5 pack)
LD-TV	Replacement leak test vial
LD-PK	Parts kit (6-prong sensor, filter kit & test vial)
LD-CS	Carrying case

**EXTREMELY ACCURATE FOR ALL HFC, HCFC AND  
BLENDED REFRIGERANTS  
AS WELL AS NEW HFO REFRIGERANTS**

**R-410A**  
.05 oz/yr

**R-22**  
.025 oz/yr

**R-404A**  
.05 oz/yr

**R-134a**  
.05 oz/yr

**R-407A**  
.05 oz/yr

**R-427A**  
.05 oz/yr

**R-1234yf**  
.0125 oz/yr

# LDC-4000

COMBUSTIBLE GAS & HC REFRIGERANT LEAK DETECTOR

**WARRANTY**  
24 MONTHS

**< 5 PPM**  
METHANE SENSITIVITY

**ALARM**  
AUDIBLE

ELECTRONIC  
INSTRUMENTS

## LDC-4000

COMBUSTIBLE GAS & HC REFRIGERANT LEAK DETECTOR

The new, easy-to-use LDC-4000 Combustible Gas & HC Refrigerant Leak Detector has a solid state heated sensor for high sensitivity to all HC refrigerants and combustible gases including Methane (**Natural Gas**), Propane (**R-290**), Isobutene (**R-600a**), Butane, (**LPG**), Ethane (**R-170**), as well as Acetylene, Methanol, Acetone, Gasoline and others. The LDC-4000 has a sensor life of over 300 hours and an instantaneous response time of detecting leaks as low as 5ppm of Methane.

The LDC-4000's intuitive technology features automatic calibration and is operated with one on/off power and sensitivity button. It's long, flexible probe allows for easy access into hard to reach places.

The detector is certified by the *Mine Safety and Health Administration (MSHA)* to be Intrinsically Safe in a combustible atmosphere.

**LONG LIFE, STABLE SENSOR**

**AUTOMATIC CALIBRATION AND RESET TO AMBIENT**

**COMFORTABLE SANOPRENE GRIP**

**INTRINSICALLY SAFE CERTIFIED**

**LOW BATTERY INDICATOR**



**NEW**



LDC-4000	
PART NO.	DESCRIPTION
LDC-4000	Combustible Gas and HC Refrigerant Leak Detector
LDC-4000-1	LDC-4000 Replacement sensor (4-prong)
LDC-4000-2	LDC-4000 Replacement sensor cover
LDC-4000-3	Combustible leak test vial
LDC-4000-4	LDC-4000 Carrying case
LDC-4000-5	LDC-4000 Instruction manual

# AURORA

## LD-6000IR INFRARED REFRIGERANT LEAK DETECTOR

**INFRARED SENSOR  
LIFE TESTED TO  
LAST UP TO 10  
YEARS**

SENSITIVITY CAN  
BE PROGRAMMED  
TO HIGH, MEDIUM  
AND LOW

**ACCURATE TO 0.10  
OZ./YEAR**

CONVENIENT  
CARRYING CASE

**MAGNETIC HANGER**

EIGHT SEGMENT  
EASY-TO-READ  
LED DISPLAY

**PEAK FUNCTION  
STORES THE  
HIGHEST CHANGE  
IN REFRIGERANT  
CONCENTRATION  
ACHIEVED WHILE  
CONTINUING TO  
DETECT LEAKS**

8-HOUR  
RECHARGEABLE  
LITHIUM ION  
BATTERY

**WON'T TRIGGER ON  
OIL OR MOISTURE**

**WARRANTY**  
12 MONTHS

**SENSOR LIFE**  
UP TO  
10 YEARS

**LED DISPLAY**  
VISIBILITY EVEN IN  
BRIGHT ENVIRONMENTS

**ALARM**  
AUDIBLE &  
VISUAL LED GRAPH

## LD-6000IR

### INFRARED REFRIGERANT LEAK DETECTOR

Extremely accurate for all CFC, HFC, HFO, and HCFC blend refrigerants there is simply no better hand-held infrared leak detector on the market.

Why did we name this leak detector the Aurora? JB has been manufacturing equipment for the refrigeration and air conditioning industry since its inception in 1967 out of Aurora, Illinois. In 1908, the city's official motto became the "City of Lights." Aurora was one of the first American cities to install street lights, and because this infrared leak detector is our first to use the power of light, the name Aurora fit perfectly.

**EXTREMELY ACCURATE FOR ALL CFC, HFC, HFO,  
AND HCFC BLEND REFRIGERANTS INCLUDING  
BUT NOT LIMITED TO:**

R-410A	R-22
R-404A	R-134a
R-407A	R-427A
R-502	R-1234yf

- 1 *Eight segment easy-to-read led display*
- 2 *8-Hour lithium ion battery*
- 3 *Won't trigger on oil or moisture*



# THE BEST LEAK DETECTION TECHNOLOGY IN THE INDUSTRY

## CERTIFIED TO SAE J2791 AND SAE J2913 LEAK DETECTION STANDARDS

Collisions of energetically charged particles with atoms create the light spectaculars known as “auroras,” part of the inspiration behind JB's Aurora Leak Detector. This new leak detector puts the power of light to good use, helping you find the smallest of leaks. No longer are auroras something to just be admired because of their colors; they can now be admired for their leak detecting capabilities.

Weighing in at less than a pound, the lightweight Aurora's advanced infrared sensor has been designed and tested to discover leaks of CFC, HFC, HFO, and HCFC refrigerants accurately for more than 10 years. When a leak is detected, not only will you be visually alerted, but an alarm will also sound. The Aurora can be set to three sensitivity levels down to 0.10 oz/year, and automatically recalibrates in highly contaminated areas to help find exactly where the leak is coming from. In addition, the sensor will not be triggered by oil or moisture so you can be confident you have precisely found a refrigerant leak. The Aurora comes standard with an 8-hour lithium ion battery and a durable carrying case to store the unit and its accessories.

### CERTIFICATIONS INCLUDE:

ASHRAE 173, SAE J2791 & SAE J2913

\*R1234yf is a replacement for all HFC (134A) & HCFC (R-22) refrigerants that are currently being phased out. It is an A2L flammable refrigerant as defined by ASHRAE 34

#### LD-6000IR INFRARED REFRIGERANT LEAK DETECTOR

PART NO.	DESCRIPTION
LD-6000IR	Aurora leak detector in case
LDA-WE9	Wand extension - 9"
LDA-NNP4	Needle nose probe - 4 3/4"
LDA-NNP9	Needle nose probe - 9"
LDA-VCH	12v vehicle charger
LDA-WCH	120-240v wall charger
LDA-WCHUS	Wall charger -US connector
LDA-WCHUK	Wall charger -UK connector
LDA-WCHEU	Wall charger -European connector
LDA-LI	3.7v Li-ion battery 1800 mAh
LDA-WTP	Wand tip
LDA-PK	Filters for wand and probes plus O-rings (10 filters and 5 O-rings per package)

# ATLAS

USER DEFINED  
WEIGHT AND  
APPROACHING  
ALARMS

## JOB TIME RECORDING

EMAIL ACCESSIBLE  
DATA LOGGING

## ADJUSTABLE UNIT OF MEASUREMENT

LIGHT OR DARK APP  
THEME FOR VISIBILITY  
IN DIFFERENT  
ENVIRONMENTS

## INTEGRATED APP BASED MANUAL

LED CONNECTIVITY  
AND POWER LIGHTS

## WATER-RESISTANT DESIGN

### WARRANTY

24 MONTHS

### 250 LBS

WEIGHT CAPACITY  
(115 KG)

### BLUETOOTH 4.0



WIRELESS  
CONNECTIVITY

### FREE

DS-20000S  
APP

## DS-20000S

WIRELESS REFRIGERANT CHARGING SCALE

### INNOVATIVE NEWCOMER

The JB ATLAS wireless refrigerant charging scale is the new go-to heavy duty charging scale for industry professionals.

This bluetooth accessible scale features a wider, slip-resistant surface to accommodate even the larger European refrigeration tanks with a weight capacity of 250 pounds (115 kg).

The NEW JB app for the DS-20000S gives the industry professional unprecedented controls: unit of measurement setting, user defined alarms, job timing, and data logging.

Operates with four AA batteries (included).



The DS-20000S requires the use of a Bluetooth® 4.0 compatible smart device

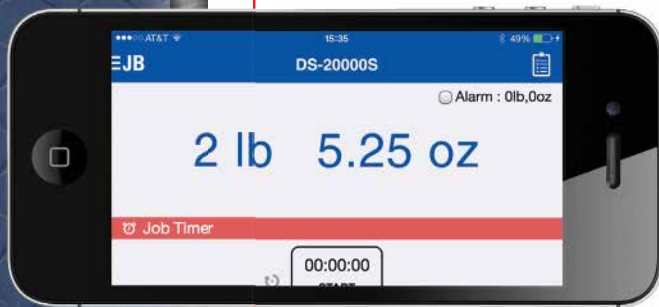

### FREE SMART DEVICE ACCESS THROUGH THE JB DS-20000S APP

- JOB TIME RECORDING
- PROGRAMMABLE ALARM SYSTEM FOR APPROACHING ALARMS
- DATA LOGGING SYSTEM FOR RECORDING & SHARING JOB STATISTICS
- LIGHT OR DARK APP THEME FOR VISIBILITY IN DIFFERENT LIGHTING ENVIRONMENTS

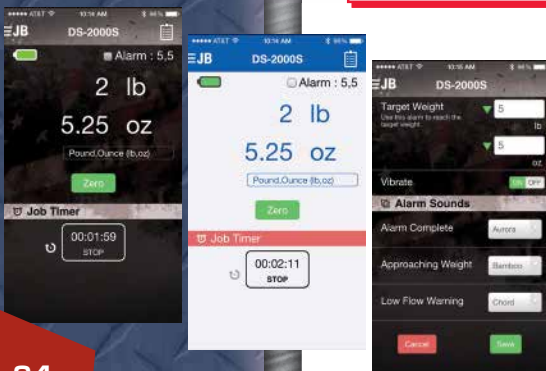

### TECHNICAL INFORMATION

USAGE	INDOOR/OUTDOOR, NOT WATERPROOF
OPERATING TEMP.	+32°F TO 122°F (0°C TO +50°C)
STORAGE TEMP.	+14°F TO 140°F (-10°C TO +60°C)
HUMIDITY	85% RH @ 113°F (45°C), NON CONDENSING
BATTERY LIFE	APPROXIMATELY 60 HOURS

### DS-20000S

PART NO.	DESCRIPTION
DS-20000S	250 lb weight capacity, wireless ATLAS scale



# REFRIGERANT CHARGING SCALES

ELECTRONIC INSTRUMENTS

**WARRANTY**  
24 MONTHS

**220 LBS**  
WEIGHT CAPACITY  
(100 KG)

**SOLID STATE**  
LOAD CELL ACCURATE  
TO .25 oz/10 g

**LCD SCREEN**  
ON HAND-HELD  
CONTROLLER

## DS-20000

REFRIGERANT CHARGING SCALE

### HEAVYWEIGHT CHAMPION

The JB ATLAS refrigerant charging scale is designed for the HVAC/R industry. Every day users will appreciate the advanced solid state load cell for superior sensitivity (0.25 oz/10 gm) and accuracy.

The ATLAS's 220 pound (100 Kg) weight capacity, all metal construction, heavy duty plastic storage case, and easy-to-read hand-held combine to make the ATLAS the best overall package in the industry. Pound for price, our 220 pound scale competes at a 110 pound price. Operates with a 9 volt battery (included).



DEALER DESIGN  
AWARDS  
THE NEWS | BRONZE

**SOLID STATE LOAD CELL ACCURATE TO 0.25 OZ/10 GM WITHOUT NEED OF CYLINDER DIRECTLY ON CENTER OF WEIGHING PLATFORM**

**LCD SCREEN ON HAND-HELD CAN BE READ FROM A DISTANCE OR IN DIRECT SUNLIGHT**

**PIECES ARE MODULARIZED SO PARTS ARE EASILY REPLACED WITHOUT NEED TO PURCHASE ENTIRELY NEW UNIT**

**DISPLAYS WEIGHT IN DECIMAL-POUNDS, POUNDS & OUNCES, AND KILOGRAMS**

**AUTO SHUT OFF AFTER 30 MINUTES TO PRESERVE BATTERY (CAN BE DISABLED)**

TECHNICAL INFORMATION	
USAGE	INDOOR/OUTDOOR, NOT WATERPROOF
OPERATING TEMP.	+32°F TO 122°F (0°C TO +50°C)
STORAGE TEMP.	+14°F TO 140°F (-10°C TO +60°C)
HUMIDITY	85% RH @ 113°F (45°C), NON CONDENSING
ALTITUDE	6500 FEET (2000 METERS)
BATTERY LIFE	APPROXIMATELY 60 HOURS

DS-20000	
PART NO.	DESCRIPTION
DS-20000	220 lb. weight capacity ATLAS scale
DSR-10	Replacement communication cable
DSR-20	Replacement hand-held remote
DSR-30	Replacement weighing platform



# MINI SPLIT TOOL KIT

## EVERYTHING YOU NEED FOR R-410A



JB offers three versatile kits featuring everything you need to install and service mini split units. MSKIT1 & MSKIT2 contain all essential tools to get the job done including the Dealer Design award winning Patriot™ 2-Valve Manifold, a Kobra® Secure Seal hose set that is UL approved for R-410A & a heavy-duty 6-spanner head torque wrench.

The MSKIT3 is an affordable solution for service technicians who already have a few basic tools in their tool box.



\* For each Patriot™, MSKIT1, or MSKIT2 sold, JB will donate to **Operation Homefront**.

To learn more about **Operation Homefront**, visit: [www.operationhomefront.net](http://www.operationhomefront.net)

INCLUDED IN MSKIT1		1/4"
PART NO.	DESCRIPTION	
MSKIT1-BAG	JB's tool bag	
22500	Patriot™ manifold with 410A gauges	
CCLS-60	1/4" KOBRA® UL approved Secure Seal hose set	
T30605	Metric (2-8mm) & Imperial (5/64 - 1/4") hex key set	
T30600	Ratcheting eccentric cone flare tool	
TRQ1080	Torque wrench set with 6 spanner heads	
A32525N	1/4" Female x 1/4" SAE Valve core remover w/side port	
SHLD-P4	SHIELD® locking cap R-410A (4 pack)	
A31656	5/16" Female x 1/4" SAE brass adapters (2 included)	
NFT5-4	1/4" Brass caps (5 included)	

INCLUDED IN MSKIT2		5/16"
PART NO.	DESCRIPTION	
MSKIT1-BAG	JB's tool bag	
22505	Patriot™ manifold with 410A gauges	
CCLS5-60	5/16" KOBRA® UL approved Secure Seal hose set	
T30605	Metric (2-8mm) & Imperial (5/64 - 1/4") hex key set	
T30600	Ratcheting eccentric cone flare tool	
TRQ1080	Torque wrench set with 6 spanner heads	
A32535N	5/16" Female x 5/16" SAE Valve core remover w/side port	
SHLD-E4	SHIELD® locking cap R-410A (4 pack)	
A31665	1/4" Female x 5/16" SAE brass adapters (2 included)	
NFT5-5	5/16" Brass caps (5 included)	



INCLUDED IN MSKIT3		1/4" & 5/16"
PART NO.	DESCRIPTION	
MSKIT1-BAG	JB's tool bag	
T30605	Metric (2-8mm) & Imperial (5/64 - 1/4") hex key set	
T30600	Ratcheting eccentric cone flare tool	
TRQ1075	Torque wrench set with 6 spanner heads	
NFT5-4	1/4" Brass caps (5 included)	
NFT5-5	5/16" Brass caps (5 included)	
A31656	5/16" Female x 1/4" SAE brass adapters (2 included)	

MSKIT3

# EVERYTHING YOU NEED FOR R410-A DUCTLESS MINI-SPLITS IN ONE CONVENIENT KIT

## PRODUCT DESCRIPTIONS



**MADE  
IN USA**

**22500 · 22505<sup>5/16"</sup>**

Patriot™ manifold with surge dampened R-410A gauges & 360° swiveling hose holders.



**MADE  
IN USA**

**CCLS-60 · CCLS5-60<sup>5/16"</sup>**

KOBRA® Secure sealed refrigerant charging hoses. With low-loss, UL-approved for R-410A.



**TRQ1080**

7.375-59.004 pound-feet (10-80 N-M) torque wrench with 6 spanner heads (17, 22, 24, 26, 27 & 29 mm) & 1/2" DR Ratchet head.

MINI SPLIT  
TOOL KIT



**T30600**

Ratcheting, eccentric cone flaring tool with internal clutch to prevent over-torquing. For tube OD: 3/16", 1/4", 5/16", 3/8", 1/2", 5/8" & 3/4"



**MADE  
IN USA**

**A32525N · A32535N<sup>5/16"</sup>**

Valve core remover tool with side port for removing valve cores without losing system charge.



**MADE  
IN USA**

**SHLD-P4 · SHLD-E4<sup>5/16"</sup>**

SHIELD® Refrigerant locking cap with water-resistant rubber sleeves color coded for R-410A.



**MADE  
IN USA**

**T30605**

Metric (2-8 mm) and Imperial (5/64" - 1/4") hex key sets.



**MADE  
IN USA**

**NFT5-4 · NFT5-5<sup>5/16"</sup>**

Five finger-tight 1/4" o-ring sealed brass caps.



**MADE  
IN USA**

**A31656 · A31665<sup>5/16"</sup> MALE**

Brass adapters for 5/16" - 1/4" SAE connections.

## ACCESSORIES:



**NEW**

**JB-TOOLBAG1**

Heavy duty canvas JB tool bag



**NEW**

**JB-BACKPACK1**

Heavy duty JB canvas backpack



**NEW**

5/8", 13/16"  
15/16", 1-1/8"

**TRQ-IMP**

Torque wrench imperial heads for TRQ1080

# PATRIOT™

2-VALVE BRASS MANIFOLD

## THE MANIFOLD THAT GIVES BACK

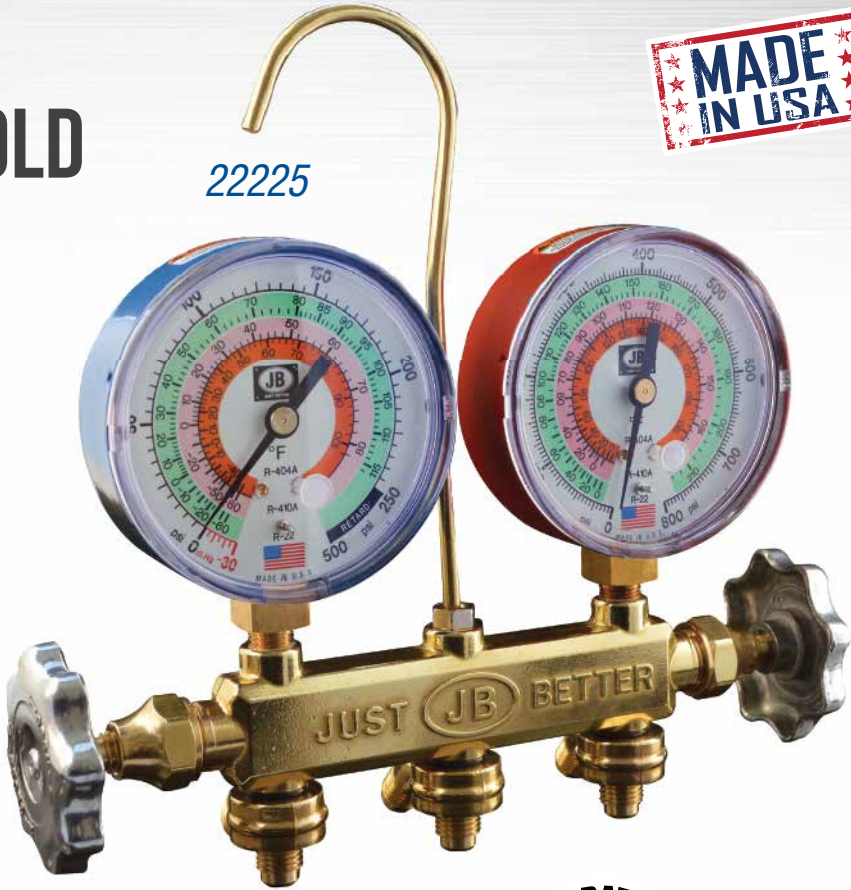

## PATRIOT™ 2-VALVE MANIFOLD

JB Industries is proud to introduce the Patriot™ 2-Valve Brass Manifold. Its sleek new bar design paired with easy to grip metal handles and 3-1/8" metal class 1 illuminating gauges will make it the go-to manifold for HVAC techs.

In addition to these new features, we have incorporated some of our best manifold features such as a free floating O-ring system and swiveling hose holder fittings that are replaceable.

Gauge features and replacements are detailed on page 42-43. Gauge boots are featured on page 43. Metric replacement gauge versions are detailed on page 42. KOBRA® hoses are detailed beginning on page 44.



For each Patriot™, MSKIT1, or MSKIT2 sold, JB will donate to **Operation Homefront** to support their vision of being the provider of choice for emergency financial and other assistance to the families of our service members and wounded warriors.

Together, we hope to give back to those who have given so much.

To learn more about **Operation Homefront**, visit: [www.operationhomefront.net](http://www.operationhomefront.net)

**PATRIOT™ MANIFOLD AVAILABLE IN THE JB MSKIT**



**SURGE DAMPENED GAUGES FOR REDUCED NEEDLE MOVEMENT**

ORIGINAL FREE FLOATING DUAL O-RING SEALING SYSTEM FOR FASTER EVACUATION/CHARGING

**ALL METAL, CLASS ONE (1%) GAUGES**

360° SWIVELING HOSE HOLDERS

**PULL-OUT PROOF HANGING HOOK**

REPLACEABLE INTAKE/HOSE HOLDER FITTINGS FOR STORAGE

**EASY TURNING METAL HAND WHEELS**

SOLID BRASS FORGING

**NEW CAMO DESIGN GAUGES AVAILABLE**

## TO FIND THE RIGHT MANIFOLD

Choose the desired refrigerant combination  
 Select the hose set that suits your needs  
 Move across the chart to find the gauges and your model number

MANIFOLDS

**R-22** **R-404A** **R-410A**

INCLUDES DESIGNATED HOSE SET (UNLESS NOTED)	3-1/8" GAUGES Illuminating Camo 1% Class	3-1/8" GAUGES Illuminating 1% Class
MANIFOLD ONLY	22225CM	22225
CCLC 60" KOBRA® HOSES	22233CM	22233
CCLS 60" KOBRA® HOSES UL R-410A SECURE SEAL	22246CM	22246

**R-22** **R-134a** **R-404A**

INCLUDES DESIGNATED HOSE SET (UNLESS NOTED)	3-1/8" GAUGES Illuminating Class	3-1/8" GAUGES Illuminating 1% Class
MANIFOLD ONLY	---	22125
CCLC 60" KOBRA® HOSES	22131	22133

**R-410A**

INCLUDES DESIGNATED HOSE SET (UNLESS NOTED)	2-1/2" GAUGES R-410A Only (3/2/3 %)	3-1/8" GAUGES R-410A Only
MANIFOLD ONLY	22500	22525
CCLC 60" KOBRA® HOSES	---	22531
MANIFOLD ONLY - 5/16" HOSE HOLDERS	22505	---

## NEW BACK-LIT LED GAUGES

**R-22** **R-404A** **R-410A**

INCLUDES DESIGNATED HOSE SET (UNLESS NOTED)	3-1/8" GAUGES Coin-cell battery LED Gauges
MANIFOLD ONLY	22225L



## JB INDUSTRIES' FIRST DONATION TO OPERATION HOMEFRONT

# M2 STANDARD MANIFOLD

## 2-VALVE CLASSIC BRASS MANIFOLD

**SURGE DAMPENED  
GAUGES FOR REDUCED  
NEEDLE MOVEMENT**

ALL METAL GAUGES  
AVAILABLE IN 2-1/2"  
AND 3-1/8" SIZE  
GAUGES WITH AND  
WITHOUT BOOTS

**COLOR-CODED  
REFRIGERANT DIALS  
FOR EASY READING**

PULL-OUT PROOF  
HANGING HOOK

**REPLACEABLE INTAKE/  
HOSE HOLDER FITTINGS  
FOR STORAGE**

EASY TURNING PLASTIC  
HAND WHEELS (METAL  
AVAILABLE ON SELECT  
MODELS)



M2-22231



### ORIGINAL FREE FLOATING DUAL O-RING SEALING SYSTEM

FOR FASTER EVACUATION & CHARGING

- 1 Double o-ring
- 2 Stem seats retract completely for full flow path
- 3 Zero leakage high pressure raised seat for positive seating

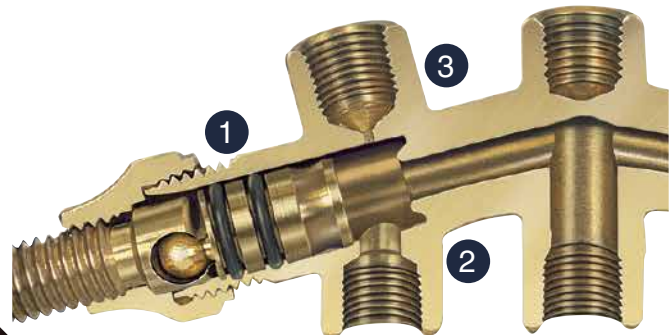

Refer to "manifold repair parts" beginning on page 83 for all JB manifold repair parts. If you do not see a refrigerant combination, please contact us at 800.323.0811.

# TO FIND THE RIGHT MANIFOLD

Choose the desired refrigerant combination  
 Select the hose set that suits your needs  
 Move across the chart to find the gauges and your model number

## THE INDUSTRY STANDARD

The industry standard for countless years, the JB M2 series of manifolds features our full flow design for faster evacuation/charging. Coupled with an angled bar for better knuckle clearance in rotating the hand wheels, and the original free flowing dual O-ring sealing system, the M2 is the classic American made manifold. All of JB's brass manifolds are equipped with heavy-duty metal gauge cases for added durability.

**R-22** **R-404A** **R-410A** \* AVAILABLE WITH SILVER METAL HANDLES, PLEASE ORDER M2-8-410AM AND M2-5-410AM RESPECTIVELY.

INCLUDES DESIGNATED HOSE SET (UNLESS NOTED)	2-1/2" GAUGES	2-1/2" GAUGES w/Boots	3-1/8" GAUGES Illuminating 1% Class	3-1/8" GAUGES Illuminating
MANIFOLD ONLY	M2-8-410A*	M2-8-410AB	M2-23225	M2-22225
CCLE 60" KOBRA® HOSES	M2-5-410A*	M2-5-410AB	M2-23231	M2-22231
CCLS 60" KOBRA® HOSES UL R-410A SECURE SEAL	M2-5-410A-SS	---	---	M2-22244

**R-22** **R-134a** **R-404A**

INCLUDES DESIGNATED HOSE SET (UNLESS NOTED)	2-1/2" GAUGES	2-1/2" GAUGES w/Boots	3-1/8" GAUGES Illuminating 1% Class	3-1/8" GAUGES Illuminating
MANIFOLD ONLY	M2-21125	M2-21125B	M2-23125	M2-22125
CCLE 60" KOBRA® HOSES	M2-21131	M2-21131B	M2-23131	M2-22131

**R-12** **R-22** **R-502**

INCLUDES DESIGNATED HOSE SET (UNLESS NOTED)	2-1/2" GAUGES	2-1/2" GAUGES w/Boots
MANIFOLD ONLY	M2-8	M2-8B
CL 36" RED & BLUE HOSES, CL 60" YELLOW HOSE	M2-6	M2-6B
CCL 60" STANDARD HOSE	M2-5	M2-5B
CCL 36" STANDARD HOSE	M2-36	M2-36B

**R-410A**

INCLUDES DESIGNATED HOSE SET (UNLESS NOTED)	2-1/2" GAUGES R-410A Only	2-1/2" GAUGES R-410A Only	3-1/8" GAUGES R-410A Only
MANIFOLD ONLY	M2-21525	M2-21525B	M2-22525
CCLE 60" KOBRA® HOSES	M2-21531	M2-21531B	M2-22531

**R-427A** **R-422B** **R-407A**

INCLUDES DESIGNATED HOSE SET (UNLESS NOTED)	3-1/8" GAUGES Illuminating
MANIFOLD ONLY	M2-22325

**R-22** **R-410A** **R-407C**

INCLUDES DESIGNATED HOSE SET (UNLESS NOTED)	3-1/8" GAUGES Illuminating
MANIFOLD ONLY	M2-22425

## METRIC INFORMATION

Offered with 63.5mm (2 1/2") metric gauges reading BAR/PSI, kPa/PSI, and kg/cm<sup>2</sup>. For information on metric versions, please refer to page 41.

Gauge features and replacements are detailed on **page 42-43**. Gauge boots are featured on **page 43**. Metric replacement gauge versions are detailed on **page 42**. KOBRA® hoses are detailed beginning on **page 44**.

MANIFOLDS

# 2-VALVE FORGED ALUMINUM MANIFOLD

# ZEPPELIN®

## SURGE DAMPENED GAUGES FOR REDUCED NEEDLE MOVEMENT

ORIGINAL FREE  
FLOATING DUAL  
O-RING SEALING  
SYSTEM FOR FASTER  
EVACUATION AND  
CHARGING

## AVAILABLE WITH 2-1/2" AND 3-1/8" SIZE GAUGES

COLOR-CODED  
REFRIGERANT DIALS  
FOR EASY READING

## PULL-OUT PROOF HANGING HOOK

PRECISELY MACHINED  
ANODIZED ALUMINUM  
BODY

## REPLACEABLE INTAKE/ HOSE HOLDER FITTINGS FOR STORAGE

SOFT GRIP RUBBER  
HAND-WHEELS  
REDUCE TURNING TO  
OPEN/CLOSE

## ALL METAL GAUGES



24225



The American made 2-valve Zeppelin® series of aluminum manifolds are machined from durable, solid aluminum billets and feature rigid, durable, molded, “soft grip” rubber handles with fingertip grooves that eases opening and closing while the improved stem design means “full open” in only 2½ turns. The aluminum Zeppelin® series, also available in 4-valve, incorporates cutting edge styling and technology to significantly reduce the weight of the manifold.

In addition, JB also offers an increased selection of gauges in metal cases and refrigerant combinations. Standard 2½”, large glow-in-the-dark 3⅜”, and liquid-filled 3⅜” gauges can be coupled with different refrigerant combinations and JB’s multiple hose options to serve any application. All manifolds include a 60” (152.3 cm) hose set unless noted otherwise.





# TO FIND THE RIGHT MANIFOLD

Choose the desired refrigerant combination

Select the hose set that suits your needs

Move across the chart to find the gauges and your model number

**R-22** **R-404A** **R-410A**

INCLUDES DESIGNATED HOSE SET (UNLESS NOTED)	2-1/2" GAUGES	3-1/8" GAUGES Liquid Filled 1%	3-1/8" GAUGES Illuminating
MANIFOLD ONLY	24200	24250	24225
CCLE 60" KOBRA® HOSES	24208	24258	24233
CCLV 60" KOBRA® WHIP END BALL VALVE HOSES	---	24265	24240
CCLS 60" KOBRA® HOSES - UL R-410A SECURE SEAL	---	---	24244

**R-22** **R-134a** **R-404A**

INCLUDES DESIGNATED HOSE SET (UNLESS NOTED)	2-1/2" GAUGES	3-1/8" GAUGES Liquid Filled 1%	3-1/8" GAUGES Illuminating
MANIFOLD ONLY	24100	24150	24125
CCLE 60" KOBRA® HOSES	24108	24158	24133
CCLBV 60" KOBRA® BALL VALVE HOSES	---	24165	24140
CCLS 60" KOBRA® HOSES - UL R-410A SECURE SEAL	---	24169	24144

**R-12** **R-22** **R-502**

INCLUDES DESIGNATED HOSE SET (UNLESS NOTED)	2-1/2" GAUGES	3-1/8" GAUGES Liquid Filled 1%	3-1/8" GAUGES Illuminating
MANIFOLD ONLY	24000	24050	24025
CCLE 60" KOBRA® HOSES	24008	24058	24033
CCLBV 60" KOBRA® BALL VALVE HOSES	---	24065	24040
CCLS 60" KOBRA® HOSES - UL R-410A SECURE SEAL	---	24069	24044

**R-410A**

INCLUDES DESIGNATED HOSE SET (UNLESS NOTED)	2-1/2" GAUGES R-410A Only	3-1/8" GAUGES R-410A Only
MANIFOLD ONLY	24500	24525
CCLE 60" KOBRA® HOSES	24508	24533

**R-427A** **R-422B** **R-407A**

INCLUDES DESIGNATED HOSE SET (UNLESS NOTED)	3-1/8" GAUGES Illuminating
MANIFOLD ONLY	24325

**R-22** **R-410A** **R-407C**

INCLUDES DESIGNATED HOSE SET (UNLESS NOTED)	3-1/8" GAUGES Illuminating
MANIFOLD ONLY	24425

**R-22** **R-134a** **R-404A** **R-410A**

INCLUDES DESIGNATED HOSE SET (UNLESS NOTED)	3-1/8" GAUGES Liquid Filled 1%
MANIFOLD ONLY	24600
CCLE KOBRA® HOSES	24608
CCLBV 60" KOBRA® HOSES w/BALL VALVE	24615

Gauge features and replacements are detailed on **page 42-43**. Gauge boots are featured on **page 43**. Metric replacement gauge versions are detailed on **page 42**. KOBRA® hoses are detailed beginning on **page 44**.

Refer to "manifold repair parts" beginning on **page 83** for all JB manifold repair parts. If you do not see a refrigerant combination, please contact us at **800.323.0811**.

MANIFOLDS

# 4-VALVE FORGED ALUMINUM MANIFOLD

# ZEPPELIN®

**SURGE DAMPENED  
GAUGES FOR  
REDUCED NEEDLE  
MOVEMENT**

FULL 3/8" BORE  
EVACUATES 40%  
FASTER THAN THE  
COMPETING 4-VALVE  
MANIFOLD

**AVAILABLE WITH  
2-1/2", 3-1/8" & 4"  
SIZE GAUGES**

REPLACEABLE  
INTAKE/HOSE HOLDER  
FITTINGS FOR  
STORAGE (ON BACK)

**COLOR-CODED  
REFRIGERANT DIALS  
FOR EASY READING**

PULL-OUT PROOF  
HANGING HOOK

**PRECISELY MACHINED  
ANODIZED ALUMINUM  
BODY**

SOFT GRIP RUBBER  
HAND WHEELS  
REDUCE TURNING TO  
OPEN/CLOSE

**HEAVY-DUTY FORGED  
ALUMINUM BODY IS  
RUGGED & DURABLE**

## 3/8" BORE ALUMINUM MANIFOLD

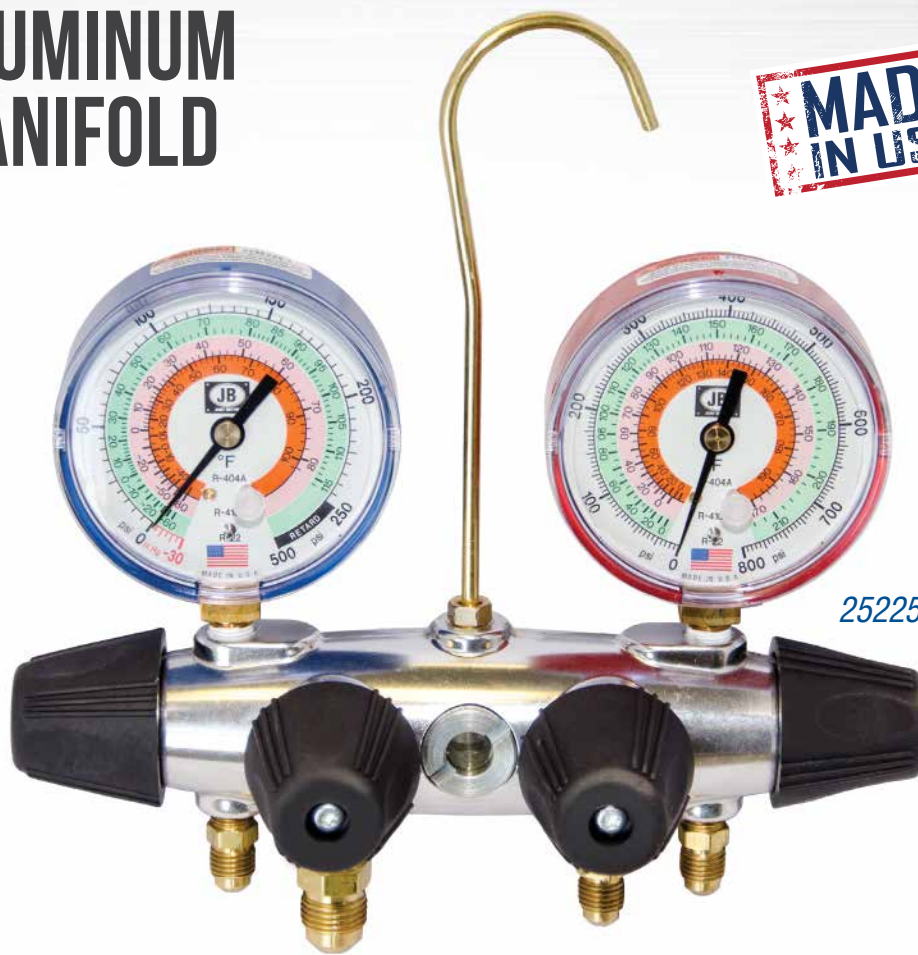

The American made Zeppelin® series of aluminum manifolds features durable molded rigid “soft grip” rubber handles with fingertip grooves that eases opening and closing while the improved stem design means “full open” in only 2½ turns. The aluminum Zeppelin® series, also available in 2-valve, incorporates cutting edge styling and technology to significantly reduce the weight of the manifold.

In addition, JB also offers an increased selection of gauges in metal cases and refrigerant combinations. Standard 2½”, large 3⅜” glow-in-the-dark, large 3⅜” liquid-filled gauges, and a four refrigerant 4” gauge (available only on the 4-valve Zeppelin®) can be coupled with different refrigerant combinations and JB’s multiple hose options to serve any application. All manifolds include a 60” (152 cm) hose set unless noted otherwise.

# TO FIND THE RIGHT MANIFOLD

Choose the desired refrigerant combination  
 Select the hose set that suits your needs  
 Move across the chart to find the gauges and your model number

MANIFOLDS

**R-22** **R-404A** **R-410A**

INCLUDES DESIGNATED HOSE SET PLUS A 3/8" KOBRA® BLACK CHARGING HOSE (UNLESS NOTED)	2-1/2" GAUGES	3-1/8" GAUGES <i>Liquid Filled 1%</i>	3-1/8" GAUGES <i>Illuminating</i>	3-1/8" GAUGES <i>Coin-cell battery LED Gauges</i>
MANIFOLD ONLY	25200	25250	25225	25225L
CCLE 60" KOBRA® HOSES	25208	25258	25233	---
CCLBV 60" KOBRA® BALL VALVE HOSES	---	25265	25240	---
CCLV 60" KOBRA® WHIP END BALL VALVE HOSES	---	25269	25244	---
CCLS 60" KOBRA® HOSES - UL R-410A SECURE SEAL	---	---	25246	---

**R-22** **R-134a** **R-404A**

INCLUDES DESIGNATED HOSE SET PLUS A 3/8" KOBRA® BLACK CHARGING HOSE (UNLESS NOTED)	2-1/2" GAUGES	3-1/8" GAUGES <i>Liquid Filled 1%</i>	3-1/8" GAUGES <i>Illuminating</i>
MANIFOLD ONLY	25100	25150	25125
CCLE 60" KOBRA® HOSES	25108	25158	25133
CCLBV 60" KOBRA® BALL VALVE HOSES	---	25165	25140
CCLS 60" KOBRA® HOSES - UL R-410A SECURE SEAL	---	25169	25144

**R-12** **R-22** **R-502**

INCLUDES DESIGNATED HOSE SET PLUS A 3/8" KOBRA® BLACK CHARGING HOSE (UNLESS NOTED)	2-1/2" GAUGES	3-1/8" GAUGES <i>Liquid Filled 1%</i>	3-1/8" GAUGES <i>Illuminating</i>
MANIFOLD ONLY	25000	25050	25025
CCLE 60" KOBRA® HOSES	25008	25058	25033
CCLBV 60" KOBRA® BALL VALVE HOSES	---	25065	25040
CCLS 60" KOBRA® HOSES - UL R-410A SECURE SEAL	---	25069	25044

**R-410A**

INCLUDES DESIGNATED HOSE SET PLUS A 3/8" KOBRA® BLACK CHARGING HOSE (UNLESS NOTED)	2-1/2" GAUGES <i>R-410A Only</i>	3-1/8" GAUGES <i>Liquid Filled R-410A Only</i>	3-1/8" GAUGES <i>R-410A Only</i>
MANIFOLD ONLY	25500	25550	25525
CCLE 60" KOBRA® HOSES	25508	25558	25533
CCLV 60" KOBRA® WHIP END BALL VALVE HOSES	25523	25573	25548

**R-427A** **R-422B** **R-407A**

INCLUDES DESIGNATED HOSE SET PLUS A 3/8" KOBRA® BLACK CHARGING HOSE (UNLESS NOTED)	3-1/8" GAUGES <i>Liquid Filled 1%</i>	3-1/8" GAUGES <i>Illuminating</i>
MANIFOLD ONLY	25608	25325

**R-22** **R-410A** **R-407C**

INCLUDES DESIGNATED HOSE SET PLUS A 3/8" KOBRA® BLACK CHARGING HOSE (UNLESS NOTED)	3-1/8" GAUGES <i>Illuminating</i>
MANIFOLD ONLY	25425

**R-22** **R-134a** **R-404A** **R-410A**

INCLUDES DESIGNATED HOSE SET PLUS A 3/8" KOBRA® BLACK CHARGING HOSE (UNLESS NOTED)	3-1/8" GAUGES <i>Illuminating</i>
MANIFOLD ONLY	25708
CCLV 60" KOBRA® WHIP END BALL VALVE HOSES	25713

Gauge features and replacements are detailed on **page 42-43**. Gauge boots are featured on **page 43**. Metric replacement gauge versions are detailed on **page 42**. KOBRA® hoses are detailed beginning on **page 44**.

Refer to "manifold repair parts" beginning on **page 83** for all JB manifold repair parts. If you do not see a refrigerant combination, please contact us at **800.323.0811**.

# REVOLVER

## 4-VALVE BALL VALVE MANIFOLD

**THE FIRST MANIFOLD WITH INTEGRATED LIQUID CHARGING CAPABILITY**

THE METERING BALL VALVE ADJUSTS TO FINITE OPENINGS FOR LIQUID CHARGING

**QUARTER TURN FULL OPEN/CLOSE HANDLE**

FOUR INTERNAL BALL VALVES

**3/8" PORT FOR FASTER EVACUATION**

AVAILABLE WITH 2-1/2" AND 3-1/8" SIZE GAUGES

**360° SWIVELING HOSE HOLDERS FOR GREATER FLEXIBILITY**

PULL-OUT PROOF HANGING HOOK

**SOFT GRIP RUBBER HAND WHEELS REDUCE TURNING TO OPEN/CLOSE**

SURGE DAMPENED GAUGES FOR REDUCED NEEDLE MOVEMENT

**ALL METAL GAUGES**

## THE FIRST BALL VALVE MANIFOLD

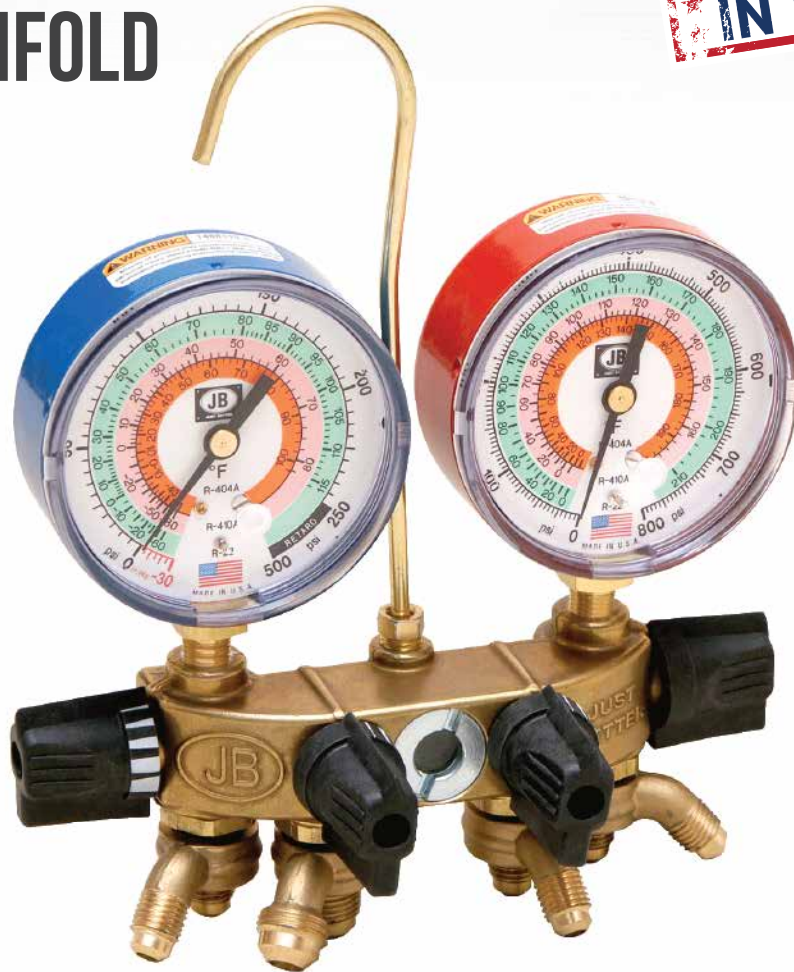

The only ball valve manifold on the market, the Revolver® features four internal metering ball valves that adjust to do finite openings for liquid charging and a sturdy brass construction with hose holders that swivel to the front or back for greater flexibility.

Handles are a quarter turn to full open and close with gradient marks to help in liquid charging. The full 3/8" bore lets you work quickly and efficiently.

## TO FIND THE RIGHT MANIFOLD

Choose the desired refrigerant combination  
 Select the hose set that suits your needs  
 Move across the chart to find the gauges and your model number

<b>R-22</b> <b>R-404A</b> <b>R-410A</b>	INCLUDES DESIGNATED HOSE SET PLUS A 3/8" KOBRA® BLACK CHARGING HOSE (UNLESS NOTED)		
	2-1/2" GAUGES	3-1/8" GAUGES <i>Illuminating</i>	3-1/8" GAUGES <i>Coin-cell battery LED Gauges</i>
MANIFOLD ONLY	26200	26225	26225L
CCLC 60" KOBRA® HOSES	26208	26233	---
CCLBV 60" KOBRA® BALL VALVE HOSES	---	26240	---
CCLV 60" KOBRA® WHIP END BALL VALVE HOSES	---	26244	---
CCLS 60" KOBRA® HOSES - UL R-410A SECURE SEAL	---	26246	---

<b>R-22</b> <b>R-134a</b> <b>R-404A</b>	INCLUDES DESIGNATED HOSE SET PLUS A 3/8" KOBRA® BLACK CHARGING HOSE (UNLESS NOTED)	
	2-1/2" GAUGES	3-1/8" GAUGES <i>Illuminating</i>
MANIFOLD ONLY	26100	26125
CCLC 60" KOBRA® HOSES	26108	26133
CCLBV 60" KOBRA® BALL VALVE HOSES	---	26140
CCLS 60" KOBRA® HOSES - UL R-410A SECURE SEAL	---	26144

<b>R-12</b> <b>R-22</b> <b>R-502</b>	INCLUDES DESIGNATED HOSE SET PLUS A 3/8" KOBRA® BLACK CHARGING HOSE (UNLESS NOTED)	
	2-1/2" GAUGES	3-1/8" GAUGES <i>Illuminating</i>
MANIFOLD ONLY	26000	26025
CCLC 60" KOBRA® HOSES	26008	26033
CCLBV 60" KOBRA® BALL VALVE HOSES	---	26040
CCLS 60" KOBRA® HOSES - UL R-410A SECURE SEAL	---	26044

MANIFOLDS

## REVOLVER® LIQUID CHARGING

**REVOLVER®  
Full Open Position**



**REVOLVER®  
Liquid Charging  
Position  
(1st dash)**



**REVOLVER®  
Closed Position**

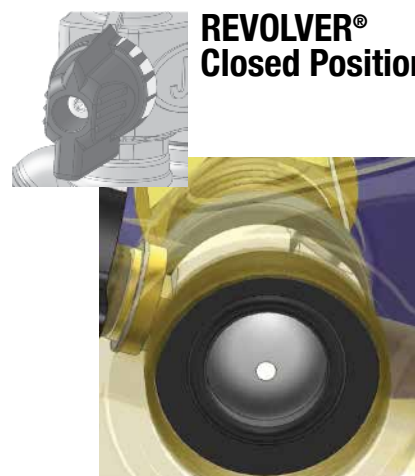

Gauge features and replacements are detailed on **page 42-43**. Gauge boots are featured on **page 43**. Metric replacement gauge versions are detailed on **page 42**. KOBRA® hoses are detailed beginning on **page 44**.

Refer to "manifold repair parts" beginning on **page 83** for all JB manifold repair parts. If you do not see a refrigerant combination, please contact us at **800.323.0811**.

# DMG2-5

## 2-VALVE DIGITAL MANIFOLD

**PREPROGRAMMED  
WITH 80+  
REFRIGERANTS**

**ROBUST  
TRANSDUCER DESIGN**

**SIMULTANEOUS  
CALCULATION OF  
SUPERHEAT AND  
SUBCOOL**

**STURDY BODY  
DESIGNED FOR  
RESILIENCY**

**HEAVY DUTY K-TYPE  
THERMAL COUPLES  
INCLUDED**

**SIMPLE AND  
ACCESSIBLE DATA  
DISPLAY**

**MADE IN SPAIN**



**DMG2-TC**  
**HEAVY DUTY K-TYPE**  
**THERMAL COUPLES**

**COMPATIBLE  
REFRIGERANTS**  
80+ PREPROGRAMMED

**UNIT OF MEASURE**  
BAR, PSI, KPA  
& MPA

**WARRANTY**  
12 MONTHS

## THE NEW 2-VALVE DIGITAL MANIFOLD

Features include easy to read screen with intuitive buttons, 80+ refrigerants are stored, simultaneous calculation of superheat and subcool, rugged carrying case, heavy duty clamps, and data logging capability (DGM2-Data accessory).



### TECHNICAL INFORMATION

<b>PRESSURE DISPLAY</b>	bar, psi, kPa, mPa
<b>TEMP. DISPLAY</b>	°F and °C
<b>VACUUM DISPLAY</b>	microns, mbar, mmHg, pascals, mtorr
<b>POWER SOURCE</b>	9V battery, included
<b>MONITOR (DIAGONAL)</b>	4 1/3" or 11 cm
<b>PRESSURE MEASUREMENT RANGE</b>	-14.5 to 870 PSI
<b>PRECISION (AT 72°C)</b>	+/- 0.5% FS
<b>TEMPERATURE MEASUREMENT RANGE</b>	-58°F to 392°F
<b>WORKING TEMP.</b>	14°F to 122°F
<b>CONNECTIONS</b>	1/4" SAE (7/16" UNF)



- R-410A
- R-404A
- R-22
- R-134a
- R-12
- R-502
- R-427A
- R-422B
- R407A

**80+ REFRIGERANTS PREPROGRAMMED INCLUDING ALL HFC, HCFC AND BLENDED REFRIGERANTS AS WELL AS NEW HFO REFRIGERANTS**



DMG2-5 2-VALVE DIGITAL MANIFOLD	
PART NO.	DESCRIPTION
DMG2-5	2-Valve digital manifold with 60" KOBRA® CCLE Hose set
DMG2-8	2-Valve digital manifold
DMG2-CASE	Heavy-duty protective carrying case
DMG2-TC	Heavy duty K-type thermal couple
DMG2-DATA	DMG2 data recording module
DMG2-VAC	DMG2 vacuum sensor module

**DMG2-CASE**  
**HEAVY-DUTY CARRYING CASE INCLUDED TO PROTECT YOUR MANIFOLD WHEN YOU'RE ON THE ROAD OR ON THE JOB**

**DMG2-VAC**  
**VACUUM SENSOR MODULE ALLOWS THE DMG2 TO READ AND RECORD VACUUM READINGS**

**DMG2-DATA**  
**DATA RECORDING MODULE STORES JOB INFORMATION FOR FUTURE DOCUMENTATION AND UPLOADING TO A COMPUTER.**

# M2 HEAT PUMP MANIFOLD

## FORGED BRASS BODY

Heat pumps use the same refrigeration cycle for heating and cooling. A heat pump can change which coil is the condenser and which is the evaporator by way of a reversing valve.

- CLASS ONE, ILLUMINATING METAL GAUGES DESIGNED FOR 800 PSI HEAT PUMP PRESSURES
- AVAILABLE WITH AND WITHOUT SET OF KOBRA® HIGH PRESSURE BLACK HOSES
- REPLACEABLE INTAKE AND HOSE HOLDER FITTINGS
- CLASSIC FORGED BRASS BODY

Using a traditional manifold to service a heat pump is not advisable as the low side of the gauge will be damaged when the system goes into heating mode. Therefore, both gauges of the manifold must be designed to handle the high pressures of the heating mode.

The JB heat pump manifold has two 3-1/8" glow-in-the-dark Class One, 1% accuracy, gauges designed for 800 psi to handle the heat pump pressures. Because of the significant temperature glide on R-407C, the pressure/temperature scale has two sections.

For temperatures below 50 degrees, the scale is based on saturated vapor (dew point DP). For temperatures above 50 degrees, the scale is based on saturated liquid (bubble point BP). Use the DP for superheat calculations and the BP for subcooling calculations.

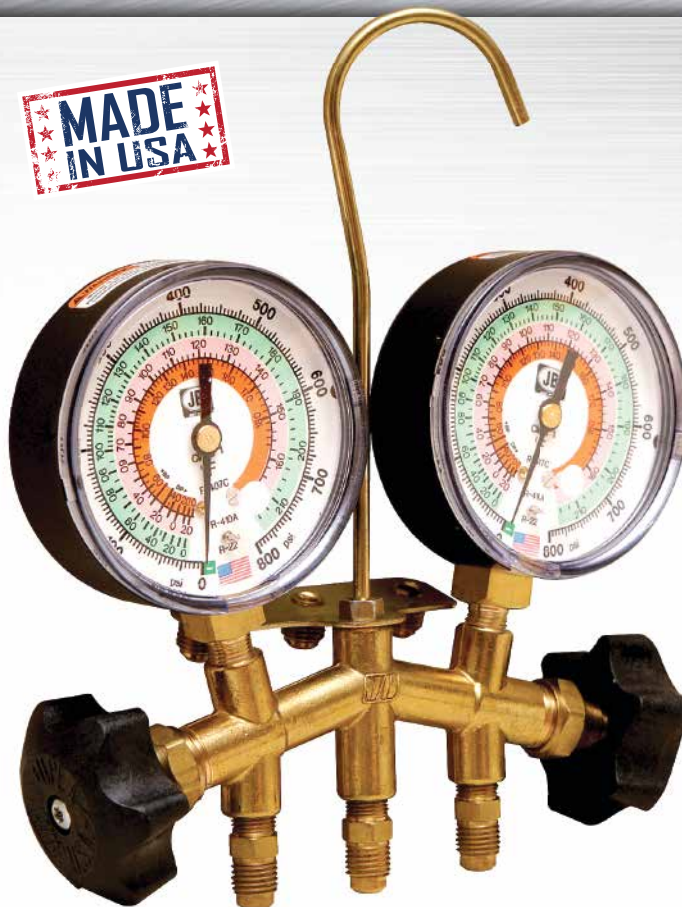

**GAUGE BOOTS**  
TURN TO PAGE 43 FOR MORE



**M2-808**  
REPLACEMENT  
HEAT PUMP  
GAUGES



R-22 R-410A R-407C

INCLUDES DESIGNATED HOSE SET (UNLESS NOTED)

MANIFOLD ONLY

THREE 60" KOBRA® BLACK CHARGING HOSES

M2-HP

M2-HP-5



# METRIC MANIFOLDS

## BAR/PSI · KPA/PSI · KG/CM<sup>2</sup>

All manifolds come with 63.5 mm (2 1/2") metric gauges in BAR/PSI, kPa/PSI, and kg/cm<sup>2</sup> as well as standard CL and KOBRA® CLE series hoses.

Refer to the M2 Brass, 2-Valve Aluminum Zeppelin®, and 4-Valve Zeppelin® pages for a full list of features for each. Also available with 80mm (3 1/8") metric gauges in select quantities. For more information, please contact [sales@jbind.com](mailto:sales@jbind.com) or 800.323.0811.



MANIFOLDS

INCLUDES DESIGNATED HOSE SET (UNLESS NOTED)	M2 BRASS			2-VALVE ZEPPELIN®			4-VALVE ZEPPELIN®		
	BAR/PSI	kPa/PSI	Kg/cm <sup>2</sup>	BAR/PSI	kPa/PSI	Kg/cm <sup>2</sup>	BAR/PSI	kPa/PSI	Kg/cm <sup>2</sup>
MANIFOLD ONLY	28592	28292	28192	28752	28852	28952	27752	27852	27952
CCL 60" KOBRA® HOSES (60"/152 cm)	28596	28296	28196	28754	28854	28954	27754	27854	27954
5/16" CCL KOBRA® HOSES (1/4" YELLOW HOSE)	28597	28297	28197	---	---	---	---	---	---
CCLBV KOBRA® HOSES w/BALL VALVE	28599	28299	28199	28759	28859	28959	27759	27859	27959

INCLUDES DESIGNATED HOSE SET (UNLESS NOTED)	M2 BRASS			2-VALVE ZEPPELIN®			4-VALVE ZEPPELIN®		
	BAR/PSI	kPa/PSI	Kg/cm <sup>2</sup>	BAR/PSI	kPa/PSI	Kg/cm <sup>2</sup>	BAR/PSI	kPa/PSI	Kg/cm <sup>2</sup>
MANIFOLD ONLY	28572	28272	28172	28772	28872	28972	27772	27872	27972
CCL STANDARD HOSES (36"/91 cm)	28570	28270	28170	28770	28870	28970	27770	27870	27970
CCL STANDARD HOSES (60"/152 cm)	28574	28274	28174	28774	28874	28974	27774	27874	27974
CCLS KOBRA® HOSES (60"/152 cm) UL R-410A SECURE SEAL	28576	28276	28176	28776	28876	28976	27776	27774	27776

INCLUDES DESIGNATED HOSE SET (UNLESS NOTED)	M2 BRASS			2-VALVE ZEPPELIN®			4-VALVE ZEPPELIN®		
	BAR/PSI	kPa/PSI	Kg/cm <sup>2</sup>	BAR/PSI	kPa/PSI	Kg/cm <sup>2</sup>	BAR/PSI	kPa/PSI	Kg/cm <sup>2</sup>
MANIFOLD ONLY	28582	28282	28182	28782	28882	28982	27782	27882	27982
CCL STANDARD HOSES (36"/91 cm)	28580	28280	28180	28780	28880	28980	27780	27880	27980
CCL STANDARD HOSES (60"/152 cm)	28584	28284	28184	28784	28884	28984	27784	27884	27984
CCL 60" KOBRA® HOSES (60"/152 cm)	28586	28286	28186	28786	28886	28986	27786	27886	27986
CCLS KOBRA® HOSES (60"/152 cm) UL R-410A SECURE SEAL	28588	28288	28188	28788	28888	28988	27788	27888	27988

INCLUDES DESIGNATED HOSE SET (UNLESS NOTED)	M2 BRASS			2-VALVE ZEPPELIN®			4-VALVE ZEPPELIN®		
	BAR/PSI	kPa/PSI	Kg/cm <sup>2</sup>	BAR/PSI	kPa/PSI	Kg/cm <sup>2</sup>	BAR/PSI	kPa/PSI	Kg/cm <sup>2</sup>
MANIFOLD ONLY	28502	28202	28102	28732	28832	28932	---	---	---
CCL STANDARD HOSES (36"/91 cm)	28505	28205	28105	28735	28835	28935	---	---	---

**28502**  
BRASS  
MANIFOLD  
BAR/PSI



**28772**  
2-VALVE  
ZEPPELIN®  
BAR/PSI



**27782**  
4-VALVE  
ZEPPELIN®  
BAR/PSI



# MANIFOLD GAUGES

## ALL MANIFOLD GAUGES FEATURE 1/8" MPT CONNECTIONS

### 2 1/2" (63.5 MM) METAL

These high quality, 2 1/2" (63.5 mm) all steel cased standard gauges are identical to the gauges used on our manifold sets. They are surge dampened for accuracy. Gauges are sensitive instruments and therefore should not be subjected to pressures beyond scale.

- HIGH IMPACT CLEAR VIEW LEXAN LENS
- RECALIBRATING SCREW
- FULL SIZE BRASS MOVEMENTS



	COMPOUND	PRESSURE
R-22 R-404A R-410A	M2-460	M2-465
R-22 R-134a R-404A	M2-430	M2-435
R-134a	M2-350	M2-355
R-410A	M2-410	M2-415
R-12 R-22 R-502	M2-250	M2-500
R-134a R-404A R-507A	M2-420	M2-425

### 3 1/8" (80 MM) ILLUMINATING

JB offers 3 1/8" (80 mm) illuminated gauges. The glow-in-the-dark dials store energy to emit light in dimly lit or dark environments.

#### R-410A ONLY

The pink non-illuminating 410A only gauges are available in both 2 1/2" & 3 1/8".



	COMPOUND	PRESSURE
R-22 R-404A R-410A	M2-820	M2-825
R-22 R-134a R-404A	M2-851	M2-856
R-410A Non-illuminating	M2-810	M2-815
R-12 R-22 R-502	M2-800	M2-805
R-22 R-410A R-407C	M2-830	M2-831
R-427A R-422B R-407A	M2-828	M2-829

### 3 1/8" 1% CALIBRATED ILLUMINATING CAMO GAUGES

JB offers 3 1/8" (80 mm) illuminated gauges. The glow-in-the-dark dials store energy to emit light in dimly lit or dark environments.



	COMPOUND	PRESSURE
R-22 R-404A R-410A	M2-924CM	M2-925CM

### 4" 1% CALIBRATED ILLUMINATING 4 REFRIGERANT

These 4" gauges feature Class One, 1% accuracy, and illuminate in low and dimly lit areas. Available on the ZEPPELIN® 4-valve manifold (see page 34). Please note, gauges may not fit on all manufacturer's manifold bodies due to the width of these gauges.

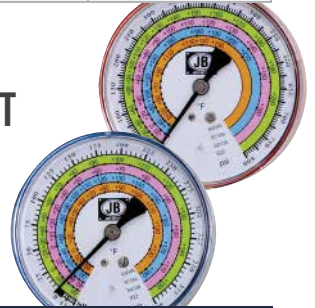

	COMPOUND	PRESSURE
R-22 R-134a R-404A R-410A	M2-400	M2-405

### 63.5 MM METRIC GAUGES

These high quality 63.5 mm (2 1/2") metric gauges are identical to the gauges used on our manifold sets. Featuring high impact Lexan lenses for better durability and visibility. Gauges are sensitive instruments and therefore should not be subjected to pressures beyond scale.

Please refer to page 41 for product information on metric manifolds.



- AVAILABLE IN BAR/PSI, KPA/PSI, AND KG/CM<sup>2</sup> MEASUREMENTS
- FULL SIZE BRASS MOVEMENTS



COMPOUND				PRESSURE			
	BAR/PSI	K/PSI	KG/CM <sup>2</sup>		BAR/PSI	K/PSI	KG/CM <sup>2</sup>
R-22 R-404A R-410A	29310	29311	29312	R-22 R-404A R-410A	29315	29316	29317
R-22 R-134a R-404A	29333	---	---	R-22 R-134a R-404A	29338	---	---
R-134a R-404A R-507	29290	---	29292	R-134a R-404A R-507	29295	---	29297
R-12 R-22 R-502	29280	29260	29384	R-12 R-22 R-502	29285	29263	29385
R-134a	29330	29331	29332	R-134a	29335	29336	29337



## LED BACK-LIT GAUGES

Back-lit by LED lights to illuminate gauge face for legibility in dark environments. Replaceable 3v Lithium coin cell battery with 250+ hour battery life included.

3 1/8"				
COMPOUND			PRESSURE	
R-22	R-404A	R-410A	M2-820L	M2-825L



## TEST GAUGES

### AVAILABLE IN OTHER REFRIGERANT COMBINATIONS

2 1/2"			COMPOUND	PRESSURE
R-22	R-404A	R-410A	QC-G460	QC-G465
3 1/8"			COMPOUND	PRESSURE
R-22	R-404A	R-410A	QC-G820	QC-G825
2 1/2"			COMPOUND	PRESSURE
R-22	R-134a	R-404A	QC-G430	QC-G434
3 1/8"			COMPOUND	PRESSURE
R-22	R-134a	R-404A	QC-G851	QC-G856



## 3 1/8" 1% CALIBRATED GAUGES

### ILLUMINATING

The illuminated gauges are also available as Class 1 gauges. Refer to the gauge tables for availability.

3 1/8"				
COMPOUND			PRESSURE	
R-22	R-404A	R-410A	M2-924	M2-925
R-22	R-134a	R-404A	M2-951	M2-956

### LIQUID FILLED

These liquid-filled gauges are simply the toughest in the industry and are backed by an extended warranty. Features an internal "breathing diaphragm" that eliminates air bubbles which can distort the reading as well as a recalibrating screw on the back of the gauge.

3 1/8"				
COMPOUND			PRESSURE	
R-22	R-404A	R-410A	M2-890	M2-895
R-22	R-134a	R-404A	M2-880	M2-885
R-12	R-22	R-502	M2-870	M2-875

## 3 1/8" 1% CALIBRATED LIQUID FILLED 4 REFRIGERANT

Made with European craftsmanship and quality standards, these Class 1 gauges are +/- 1% accurate. These 3 1/8" (80 mm) liquid-filled gauges are offered with an exclusive four refrigerant combination dial for most applications.

- TOUGH, IMPACT-RESISTANT ZYTEL CASING WITH OVER 10,000 POUND TENSILE STRENGTH
- TEMPERATURE COMPENSATED FOR CHANGES IN CASE PRESSURE FOR ACCURACY



3 1/8"					
COMPOUND			PRESSURE		
R-22	R-134a	R-404A	R-410A	M2-860	M2-865

## PROTECTIVE GAUGE BOOTS & REPLACEMENT LENSES

Protective gauge boots add even more durability to both 2-1/2" (63.5 mm) and 3-1/8" (80 mm) gauges on your manifold. They are not required on liquid-filled gauges.



MADE IN USA	
MR-590	2 1/2" Black boot
MR-593	3 1/8" Black boot
MR-594	3 1/8" Red boot for M2-865 Liquid filled, 4 refrigerant gauge
MR-595	3 1/8" Blue boot for M2-860 Liquid filled, 4 refrigerant gauge
MR-596	Set of two 3 1/8" black boots
MR-598	Set of two black JB 2 1/2" black boots
MR-593CM	Set of two 3 1/8" Camo style boots
MR-593SP	Set of two 3 1/8" Sportsman style boots
MR-517	One 2 1/2" screw-on lens fits both plastic & metal gauges
MR-533	One 3 1/8" snap-on lens

GAUGES



# KOBRA®

FAST - FIERCE - FLEXIBLE



## KOBRA® HOSES

KEVLAR LINED FOR STRENGTH AND FLEXIBILITY

ALL BRASS FITTINGS OPEN TO MAXIMUM FLOW

NO BLOWOUTS AT HIGH PRESSURES

SOLD IN UV PROTECTIVE BAGS TO PROTECT COLOR FADING

HOSE FITTINGS FIELD REPAIRABLE WITH REPLACEMENT PARTS & REBUILD KITS

### ANATOMY OF THE KOBRA® CHARGING HOSE

PROVIDES A 5-1 SAFETY FACTOR, SUPERIOR TO THE INDUSTRY STANDARD OF 4-1



- 1 Nitrile Cover
- 2 Kevlar Braid
- 3 Rubber
- 4 Veneer Tube



CCLS-60

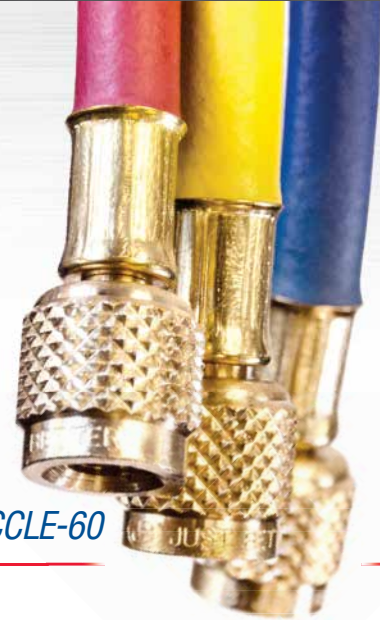

CCLE-60

## SECURE SEAL HOSES

800 PSI WORKING - 4000 PSI BURST

JB is proud to announce that our secure seal hose is the ONLY UL recognized hose for use with R-410A. Our CCLS series of KOBRA® hoses open to full flow and have a low loss fitting that traps the refrigerant inside the hose to help meet non-venting requirements. The internal thrust washer ensures free rotation. The secure seal fitting itself is rebuild-able with a parts kit. The low loss fitting is offered on our Kevlar-lined KOBRA® high pressure hose. As with all JB hoses, the CCLS KOBRA® hose is manufactured, assembled, and tested in the USA.

## GASKET SEAL HOSES

800 PSI WORKING - 4000 PSI BURST\*

Featuring a new 14 TPI pitch knurl provides an improved grip for easier sealing & greater comfort. KOBRA® CLE series and more hoses feature a blowout resistant gasket. The patent pending design of these fittings feature a hood that locks the gasket into the fitting with a straight edge to straight edge force that eliminates the blowout of the gasket. The barbed depressor locks into the gasket exuding more outward force pushing the gasket further into place. The depressor is precisely machined, has a dimple that guides the valve core into place, and is designed to provide maximum flow. Maximum flow, no blowouts, the JB difference.

\* 3/8" Gasket Sealed Hoses are 600 psi working - 3000 psi burst



JB HOSES ARE KEVLAR LINED FOR FLEXIBILITY AND STRENGTH



# MAXIMUM FLOW · NO BLOWOUTS · KEVLAR LINED

## ALL KOBRA® FITTINGS MADE AT JB

### KOBRA® CLS SERIES HOSE

SECURE SEAL UL APPROVED FOR R-410A  
AUTOMATICALLY SEALS REFRIGERANT IN.  
**800 - 4000 PSI**

- SECURE-SEAL LOW-LOSS FITTINGS UL APPROVED FOR R-410A LOCK IN REFRIGERANT WITHOUT THE NEED FOR A BALL VALVE
- FULLY REBUILD-ABLE WITH KIT\* AND SNAP RING PLIERS\*\*
- STAINLESS STEEL THRUST WASHER INSURES FREE ROTATION EVEN UNDER HIGH PRESSURE
- THREE POINT CONTACT ON DEPRESSOR

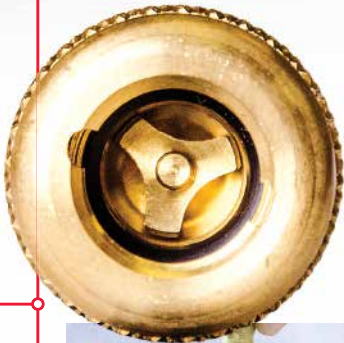

**CLS SERIES** HOSES  
FEATURE FULLY **FIELD**  
**REPAIRABLE** LOW-LOSS  
UL APPROVED FITTINGS

FULL REBUILD/REPAIR INSTRUCTIONS  
FOR CLS HOSE FITTINGS (33112N & 33113N) AVAILABLE ON [WWW.JBIND.COM](http://WWW.JBIND.COM)



**33112RK** REBUILD KIT  
INCLUDED WITH **T21295**  
SNAP RING PLIERS



**CLS HOSES** FEATURE A UL APPROVED **SECURE SEAL** SPECIALLY  
DESIGNED TO **LOCK REFRIGERANT** INSIDE THE HOSE WITHOUT  
THE NEED FOR A BALL VALVE ATTACHMENT

33113N



#### CLS SERIES - KOBRA® SECURE SEAL HOSE

LENGTH	BLUE	YELLOW	RED	BYR	4 PACK
36" (91 cm)	CLS-36B	CLS-36Y	CLS-36R	CCLS-36	CCLS4-36
48" (122 cm)	CLS-48B	CLS-48Y	CLS-48R	CCLS-48	CCLS4-48
60" (152 cm)	CLS-60B	CLS-60Y	CLS-60R	CCLS-60	CCLS4-60
72" (182 cm)	CLS-72B	CLS-72Y	CLS-72R	CCLS-72	CCLS4-72
10' (3 m)	CLS-120B	CLS-120Y	CLS-120R	---	---
25' (7.6 m)	CLS-300B	CLS-300Y	CLS-300R	---	---
50' (15.2 m)	CLS-600B	CLS-600Y	CLS-600R	---	---
75' (22.8 m)	CLS-900B	CLS-900Y	CLS-900R	---	---
100' (30.5 m)	CLS-1200B	CLS-1200Y	CLS-1200R	---	---

#### SECURE SEAL KOBRA® REBUILD PARTS & QUICK COUPLER SHUT-OFF FITTINGS

33112N	1/4" QC x 1/4" SAE
33113N	1/4" QC x 1/4" SAE 90°
33112RK*	1/4" QC rebuild kit
33115N	5/16" QC x 1/4" SAE
33116N	5/16" QC x 1/4" SAE 90°
33115RK*	5/16" QC rebuild kit
T21295**	Snap ring pliers
P90022	Replacement O-ring

#### CLS5 SERIES - 5/16" KOBRA® SECURE SEAL HOSE

LENGTH	BLUE	YELLOW	RED	BYR	4 PACK
36" (91 cm)	CLS5-36B	CLS5-36Y	CLS5-36R	CCLS5-36	---
48" (122 cm)	CLS5-48B	CLS5-48Y	CLS5-48R	CCLS5-48	---
60" (152 cm)	CLS5-60B	CLS5-60Y	CLS5-60R	CCLS5-60	---
72" (182 cm)	CLS5-72B	CLS5-72Y	CLS5-72R	CCLS5-72	---

**CLS5 SERIES KOBRA®  
HOSES, WINNER OF  
THE DEALER DESIGN  
AWARD 2014.**



BYR SET INCLUDES 5/16" BLUE AND RED HOSE WITH 1/4" YELLOW 4-PACK INCLUDES A 3/8" KOBRA® BLACK CHARGING HOSE  
LARGE NUT KOBRA® CLS SERIES HOSES ARE STILL AVAILABLE ON OUR WEBSITE. PLEASE VISIT [WWW.JBIND.COM](http://WWW.JBIND.COM) FOR MORE DETAILS.



# KOBRA®

FAST - FIERCE - FLEXIBLE



## KOBRA® CLE SERIES HOSE

GASKET-SEALED ENVIRONMENTALLY FRIENDLY,  
HIGH PRESSURE CHARGING HOSE

**800 - 4000 PSI**

- BLOW-OUT RESISTANT GASKET LOCKED INTO THE HOOD FITTING WITH A STRAIGHT EDGE TO STRAIGHT EDGE FORCE TO ELIMINATE BLOW OUTS\*
- BARBED DEPRESSOR PRECISELY MACHINED TO GUIDE THE VALVE CORE INTO PLACE.
- MAXIMUM FLOW, NO BLOW OUTS.
- EASY GRIP 14 TPI PITCH KNURL.\*\*

CLE SERIES - KOBRA® GASKET-SEALED ENVIRO HOSE					
LENGTH	BLUE	YELLOW	RED	BYR	4 PACK
36" (91 cm)	CLE-36B	CLE-36Y	CLE-36R	CCLC-36	CCLC4-36
48" (122 cm)	CLE-48B	CLE-48Y	CLE-48R	CCLC-48	CCLC4-48
60" (152 cm)	CLE-60B	CLE-60Y	CLE-60R	CCLC-60	CCLC4-60
72" (182 cm)	CLE-72B	CLE-72Y	CLE-72R	CCLC-72	CCLC4-72
10' (3 m)	CLE-120B	CLE-120Y	CLE-120R	---	---
25' (7.6 m)	CLE-300B	CLE-300Y	CLE-300R	---	---
50' (15.2 m)	CLE-600B	CLE-600Y	CLE-600R	---	---
75' (22.8 m)	CLE-900B	CLE-900Y	CLE-900R	---	---
100' (30.5 m)	CLE-1200B	CLE-1200Y	CLE-1200R	---	---

KOBRA® ENVIRO HOSE REPAIR & REPLACEMENT PARTS	
P511	1/4" CLE, CLV & CLB Series replacement gasket
P90514	CLE, CLV & CLB Series replacement depressor
P90016	3/8" KOBRA® Black & Yellow Charging Hose replacement gasket
P90008	1/2" Heavy-Duty Black Charging Hose replacement O-ring

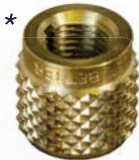

**New Ultra-coarse 14 TPI pitch knurl provides an improved grip for easier sealing & greater comfort**

\*\*

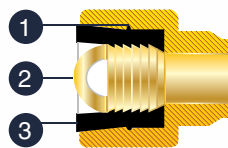

- 1 Hood
- 2 Depressor
- 3 Gasket

CCLC-60

CCLBV-60

## KOBRA® CLBV SERIES HOSE

GASKET-SEALED CHARGING HOSE WITH  
QUARTER TURN LEVER BALL-VALVE FITTINGS

**800 - 4000 PSI**

- MEET NON-VENTING REQUIREMENTS BY TRAPPING REFRIGERANT WITH BALL-VALVE FITTINGS.

CLBV SERIES - KOBRA® HOSE WITH BALL VALVE					
Length	Blue	Yellow	Red	BYR	4 Pack
36" (91 cm)	CLBV-36B	CLBV-36Y	CLBV-36R	CCLBV-36	CCLBV4-36
48" (122 cm)	CLBV-48B	CLBV-48Y	CLBV-48R	CCLBV-48	CCLBV4-48
60" (152 cm)	CLBV-60B	CLBV-60Y	CLBV-60R	CCLBV-60	CCLBV4-60
72" (182 cm)	CLBV-72B	CLBV-72Y	CLBV-72R	CCLBV-72	CCLBV4-72
72" (182 cm)	CLBV-72B	CLBV-72Y	CLBV-72R	CCLBV-72	CCLBV4-72

# MAXIMUM FLOW · NO BLOWOUTS · KEVLAR LINED

## ALL KOBRA® FITTINGS MADE AT JB

## KOBRA® CLV SERIES HOSE

GASKET-SEALED CHARGING HOSE WITH QUARTER TURN BALL-VALVE AND WHIP END FITTINGS

- QUARTER TURN LEVER BALL-VALVES WITH 6" WHIP ENDS
- MEET NON-VENTING REQUIREMENTS BY TRAPPING REFRIGERANT WITH BALL-VALVE FITTINGS.
- CLV-6 BALL-VALVE WITH WHIP END REPLACEMENTS
- CLP WHIP END ONLY REPLACEMENTS

**800 - 4000 PSI**

### CLV SERIES - KOBRA® HOSE WITH BALL VALVE WHIP END

LENGTH	BLUE	YELLOW	RED	BYR	4 PACK
36" (91 cm)	CLV-36B	CLV-36Y	CLV-36R	CCLV-36	CCLV4-36
48" (122 cm)	CLV-48B	CLV-48Y	CLV-48R	CCLV-48	CCLV4-48
60" (152 cm)	CLV-60B	CLV-60Y	CLV-60R	CCLV-60	CCLV4-60
72" (182 cm)	CLV-72B	CLV-72Y	CLV-72R	CCLV-72	CCLV4-72

### CLV SERIES - KOBRA® HOSE BALL VALVE WHIP END ONLY

1/4" x 6"	CLV-6B	CLV-6Y	CLV-6R	CCLV-6	CLV-6BL
3/8" x 6"	---	CLV6-6Y	---	---	CLV6-6BL

### CLP SERIES - KOBRA® HOSE WHIP END ONLY

6" (15 cm)	CLP-6B	CLP-6Y	CLP-6R	---	---
------------	--------	--------	--------	-----	-----

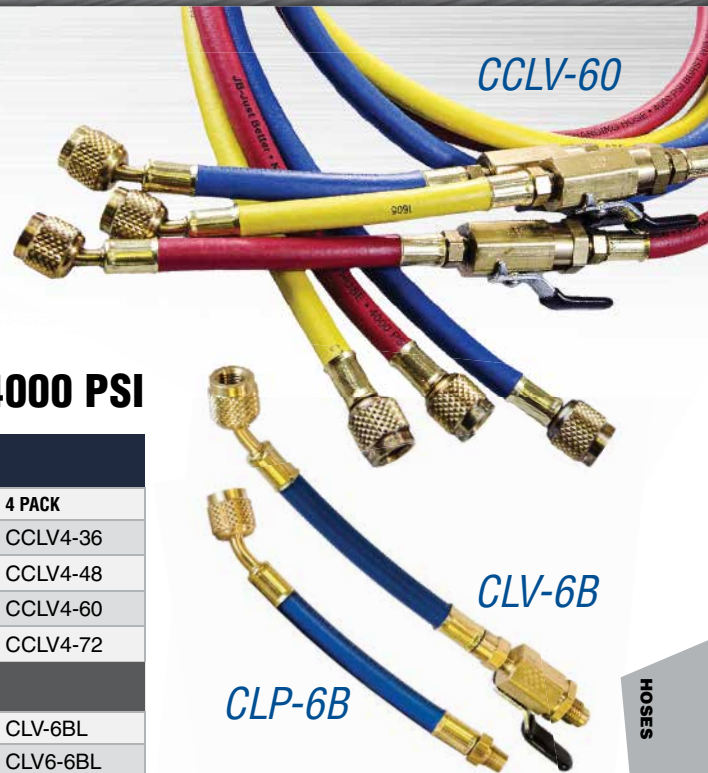

## KOBRA® CLV6 AND CL6 SERIES 3/8" BLACK & YELLOW CHARGING HOSE

Available in yellow and black, these hoses feature gasket seal fittings. Both colors of charging hose have a 600 psi working pressure and 3000 psi burst. Lined with Kevlar®, these hoses are tough and dependable. Black hoses are available with and without UL approved shut-off ball valve.

**600 - 3000 PSI**

### CLV6 & CL6 SERIES - KOBRA® 3/8" CHARGING HOSE

LENGTH	BLACK	BLACK WITH BALL-VALVE	YELLOW
36" (91 cm)	CL6-36	CLV6-36	CL6-36Y
48" (122 cm)	CL6-48	CLV6-48	CL6-48Y
60" (152 cm)	CL6-60	CLV6-60	CL6-60Y
72" (182 cm)	CL6-72	CLV6-72	CL6-72Y

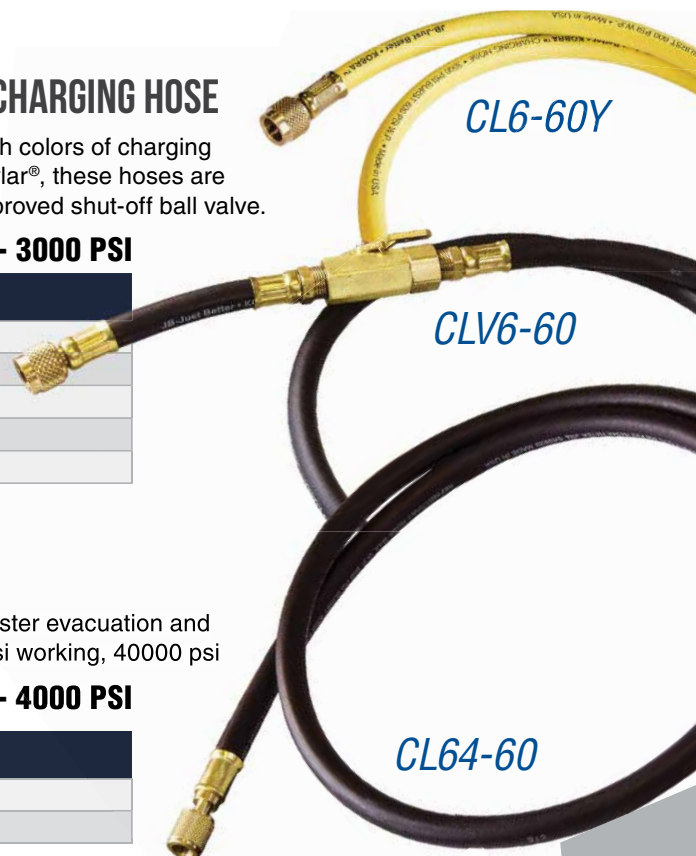

## 3/8" AND 1/2" EVACUATION HOSE

New heavy-duty evacuation hose features no valve core depressors for faster evacuation and deeper vacuums. The fittings are different on each end and handle 800 psi working, 40000 psi burst. Available in black only. Straight fittings by straight fittings.

**800 - 4000 PSI**

### 3/8" & 1/2" EVACUATION HOSE

LENGTH	1/4" X 1/2"	1/4" X 3/8"
60" (152 cm)	CL84-60	CL64-60

HOSES



# KOBRA®

FAST - FIERCE - FLEXIBLE



## 1/4", 3/8" AND 1/2" HEAVY-DUTY BLACK CHARGING HOSE

New heavy-duty charging hose reduces permeation and handle 900 psi working, 3500 psi burst. Straight fittings by straight fittings.

**900 - 3500 PSI**

HEAVY-DUTY BLACK CHARGING HOSE			
LENGTH	1/4"	3/8"	1/2"
36" (91 cm)	CL4HD-36	CL6HD-36	CL2HD-36
48" (122 cm)	CL4HD-48	CL6HD-48	CL2HD-48
60" (152 cm)	CL4HD-60	CL6HD-60	CL2HD-60
72" (182 cm)	CL4HD-72	CL6HD-72	CL2HD-72



CL4HD-60

## DEEP VACUUM FLEXIBLE METAL HOSE

**900 - 3500 PSI**

Unlike charging hose, our flexible metal lines will not permeate under vacuum. Our metal lines feature finger-tight O-ring coupler ends.



D10472

DEEP VACUUM FLEXIBLE METAL HOSE	
PART NO.	DESCRIPTION
D10436	1/4" x 36" Flexible metal line (one 45° fitting)
D10472	1/4" x 72" Flexible metal line (one 45° fitting)
D10636	3/8" x 36" Flexible metal line (one 45° fitting)
D10660	3/8" x 60" Flexible metal line (one 45° fitting)
DV-294	1/4" x 10" Flexible metal line (one 45° fitting)
P90009	1/4" Replacement O-ring (10 pack)
P90012	3/8" Replacement O-ring (10 pack)

### PERMEATION

Even with the advanced technology of today's hoses, permeation through the hose compound still exists.

When checking pressure rise, the atmosphere will permeate to the lower pressure in the hoses and the micron reading will slowly rise.

### EVACUATION

The atmosphere which has a higher pressure permeates to the lower pressure in the hose.

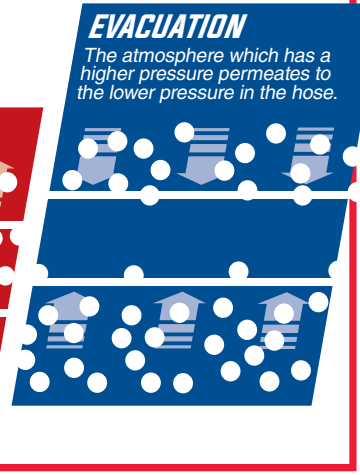
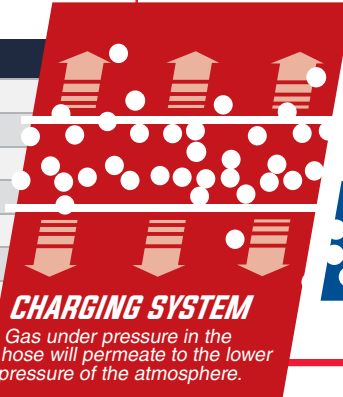

## 1/4" STANDARD CHARGING HOSE

With a pressure rating of 750 psi working and 3000 psi burst, these hoses are ideal for use with all standard refrigerants (except high pressure refrigerants). Permeation can be detected and will vary with refrigerant type and time of exposure.

**750 - 3000 PSI**

1/4" STANDARD CHARGING HOSE				
Length	Blue	Yellow	Red	BYR
36" (91 cm)	CL-36B	CL-36Y	CL-36R	CCL-36
48" (122 cm)	CL-48B	CL-48Y	CL-48R	CCL-48
60" (152 cm)	CL-60B	CL-60Y	CL-60R	CCL-60
72" (182 cm)	CL-72B	CL-72Y	CL-72R	CCL-72
72" (182 cm)	CL-72B	CL-72Y	CL-72R	CCL-72

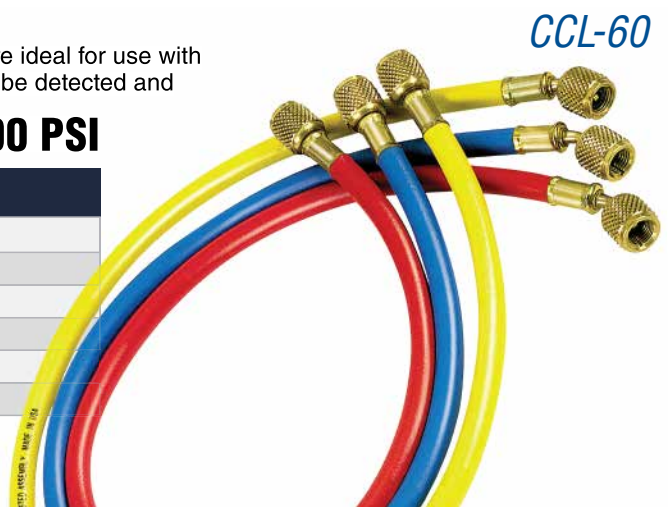

CCL-60



# KOBRA® HOSE REPAIR & REBUILD KITS

**CLS SERIES** HOSES  
 FEATURE FULLY **FIELD**  
**REPAIRABLE** LOW-LOSS  
 UL APPROVED FITTINGS

**CCLS-60**  
 SECURE SEAL  
 KOBRA® HOSE

**MADE  
 IN USA**

**33112RK**  
 SECURE SEAL  
 REBUILD KIT

**MADE  
 IN USA**

**33112N**

**33113N**

**33112RK**  
 REBUILD KIT  
 INCLUDED  
 WITH **T21295**  
 SNAP RING  
 PLIERS

**T21295**  
 SNAP RING  
 PLIERS

For full Secure Seal Disassembly/Re-Assembly instructions,  
 visit us online at [www.jbind.com](http://www.jbind.com)



**STEP 1**

Hold the cup in one hand so that the slotted face of the cup is exposed. Pinch the cup seal o-ring and insert it into the large groove to seat it correctly as shown.



**STEP 5**

Place spring into cup assembly over the boss on the back side of the depressor.



**STEP 2**

Install the barb seal o-ring in the groove located between the hex feature and the back portion of thread. Gently stretch and pull it over the threads of the barb fitting. Ensure the seal is not torn or damaged.



**STEP 6**

Screw cup assembly, with spring in an upward position, onto hose barb fitting. Hand tighten the cup to the barb ensuring cup seats over the barb gasket (o-ring) and does not damage the o-ring.



**STEP 3**

Insert bushing/seal into the thread side of the cup. Brass bushing side goes in first with seal facing up as shown.



**STEP 7**

Tighten the cup and hose barb using the 9/16" open end wrench and 1/16" steel blade. **DO NOT OVER TIGHTEN.** Only 25 to 30 in/lbs is required.



**STEP 4**

Insert depressor with 3 blade feature into the cup assembly. The depressor fits into the bushing/seal installed in the previous step. The depressor must sit flat and true to the seal surface.



**STEP 8**

Insert barb/cup assembly into the coupler. Seat the thrust washer flat onto the hose barb and inside the coupler. Now install the internal snap ring and seat it into the groove of the coupler.

HOSES

**SECURE SEAL KOBRA® REBUILD PARTS**

PART NO.	DESCRIPTION
<b>33112N</b>	1/4" QC x 1/4" SAE
<b>33113N</b>	1/4" QC x 1/4" SAE 90°
<b>33112RK</b>	1/4" QC rebuild kit
<b>33115N</b>	5/16" QC x 1/4" SAE
<b>33116N</b>	5/16" QC x 1/4" SAE 90°
<b>33115RK</b>	5/16" QC rebuild kit
<b>T21295</b>	Snap ring pliers for rebuilding KOBRA® CLS & CLS5 Secure Seal fittings
<b>P90022</b>	Replacement O-ring

**KOBRA® HOSE REPAIR & REPLACEMENT PARTS**

PART NO.	DESCRIPTION
<b>P511</b>	CLE, CLV & CLBV Series replacement gasket
<b>P90514</b>	CLE, CLV & CLBV Series replacement depressor
<b>P90016</b>	3/8" KOBRA® Black & yellow charging hose replacement gasket
<b>P90008</b>	1/4", 3/8" & 1/2" Heavy-duty black charging hose replacement o-ring

# SHIELD®

REFRIGERANT LOCKING CAP

  
 2014 DEALER DESIGN AWARDS
   
 THE NEWS | BRONZE



## SHIELD® REFRIGERANT LOCKING CAPS



*Protection from Inhalant Abuse*



*Secure, Tamper-Resistant Key*



*Stops Leakage*



*Waterproof Color-Coded Caps*



*Durable All Brass Design*



*All American Made*



SHLD-MULTI



SHLD-3-DRIVER



SHLD-8-DRIVER

With the rise of refrigerant theft and huffing related deaths, it is now code to protect your air conditioning unit's refrigerant. The American made SHIELD® Refrigerant Locking Cap does just that by saving homeowners money and helping avoid liability issues by shielding them from theft, tampering, leaking and huffing related injuries. The SHIELD's durable, all brass design paired with color coded, water-proof caps makes it the best locking cap in the industry.

### SHIELD™ LOCKING CAPS WATER RESISTANT SLEEVES INCLUDED

PART NO.	FITTING SIZE	SLEEVE COLOR-CODE	DESCRIPTION
SHLD-U4	1/4"	Universal	(4 pack) Locking caps & 1 bit
SHLD-G4	1/4"	R-22	(4 pack) Locking caps & 1 bit
SHLD-P4	1/4"	R-410A	(4 pack) Locking caps & 1 bit
SHLD-E4	5/16"	Universal	(4 pack) Locking caps & 1 bit
SHLD-U12	1/4"	Universal	(12 pack) Locking caps & 1 bit
SHLD-G12	1/4"	R-22	(12 pack) Locking caps & 1 bit
SHLD-P12	1/4"	R-410A	(12 pack) Locking caps & 1 bit
SHLD-E12	5/16"	Universal	(12 pack) Locking caps & 1 bit
SHLD-U50	1/4"	Universal	(50 pack) Locking caps, 1 bit & 3" stubby driver
SHLD-G50	1/4"	R-22	(50 pack) Locking caps, 1 bit & 3" stubby driver
SHLD-P50	1/4"	R-410A	(50 pack) Locking caps, 1 bit & 3" stubby driver
SHLD-E50	5/16"	Universal	(50 pack) Locking caps, 1 bit & 3" stubby driver
SHLD-U100	1/4"	Universal	(100 pack) Locking caps, 2 bits & 8" long driver



# MEET IMC AND IRC CODES: 1101.10 & M1411.6

## INTERNATIONAL MECHANICAL CODE

**1101.10**

Refrigerant circuit access ports located outdoors shall be fitted with locking-type tamper resistant caps.

## INTERNATIONAL RESIDENTIAL CODE

**M1411.6**

Refrigerant circuit access ports located outdoors shall be fitted with locking-type tamper resistant caps.



SHLD-P4

R-410A



SHLD-G4

R-22



SHLD-U4

UNIVERSAL

## SHLD-MULTI UNIVERSAL REFRIGERANT LOCKING CAP KEY

JB's Universal Locking Cap Key allows you to unlock SHIELD®, C&D Valve, and NOVENT® Refrigerant Locking Caps with interchangeable bits that are conveniently stored inside the tool.

- MAGNETIC TIP
- VALVE CORE REMOVER
- COMPACT DESIGN
- 3 UNIQUE BITS
- LIGHTWEIGHT
- INTERNAL STORAGE

CONVENIENT  
**1** TOOL  
FOR THESE

**4** LOCKING  
CAPS:

ACCESS  
VALVES



SHLD-MULTI



**SHIELD®**  
R-22, R-410A & UNIVERSAL



**NOVENT®**  
R-22, UNIVERSAL, R-410A & EURO



**C&D VALVE**  
UNIVERSAL



\* NOVENT® IS A TRADEMARK OF THE RECTORSEAL CORP /// C&D IS A TRADEMARK OF THE C&D VALVE COMPANY

### SHIELD® DRIVERS & ACCESSORIES

SHLD-CJ	Empty SHIELD® "Cookie jar" for storing 150 SHIELD® caps
SHLD-SLU20	Universal (black) SHIELD® sleeves (20 pack)
SHLD-SLG20	R-22 (green) SHIELD® sleeves (20 pack)
SHLD-SLP20	R-410A (pink) SHIELD® sleeves (20 pack)
SHLD-BIT	SHIELD® 2 pack bit
SHLD-3-DRIVER	SHIELD® 3" stubby driver, inc. 1 bit
SHLD-8-DRIVER	SHIELD® 8" long driver, inc. 2 bits
SHLD-COMBO-DRIVER	SHIELD® inc. 3" and 8" drivers with 2 bits
SHLD-MULTI	Universal locking cap key for SHIELD®, Novent, and C&D locking caps



# ACCESS VALVES

## ALL 100% MADE IN THE USA



### JB INDUSTRIES ACCESS VALVES

JB machines access valves at our Aurora, Illinois, facility using 100% American C360 alloy brass sourced from US mills. This gives our brass fittings and access valves high tensile strength while resisting corrosion. If you are not buying American made brass fittings, ask yourself, what is the metal content used in the imported versions, do you trust it, and can you afford to have them fail? We machine all of our valves according to the strict specifications of ARI to ensure proper sealing of valve and core surfaces. Quality and dependability come standard from an American made product.

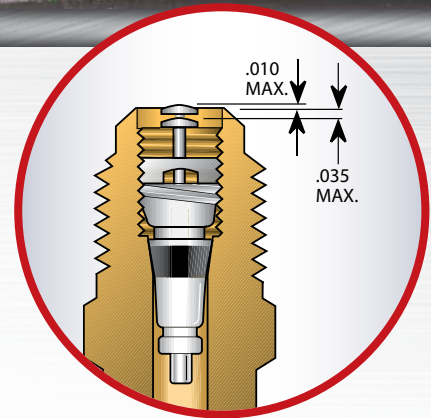

### VALVE CORE PIN LOCATION

After valve installation, the valve core can be replaced with valve core tools. Torque to ARI specifications.

### TUBE SIZING: ODS & ODF FIT DESCRIPTIONS

Descriptions for solder/braze access valves specify the connecting tube OD. Size and type fit illustrated below are the types of fit for A31723 valve. The connecting line slips around access fitting. Look under the ODF heading in the AC/R Copper Tube chart above.

There are two types. JB access valve description for ODF is always "swage fit." The connecting tube OD is the same OD as the fitting end. Therefore, A31723 above will also slip into 5/16" OD tube. If connecting to wrought copper fitting, use ODF swage size.

CONNECTING TUBE SIZE			
TUBE SIZE	ODS Internal Tube Fit	ODF External Tube Fit	ODF Swage Fit
1/8"	---	3/16"	---
3/16"	1/8"	1/4"	3/16"
1/4"	3/16"	5/16"	1/4"
5/16"	1/4"	3/8"	5/16"
3/8"	5/16"	---	3/8"

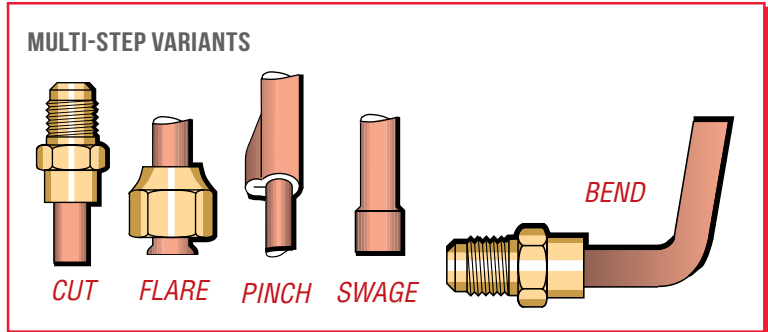

### AC/R COPPER TUBE FITTING GUIDE

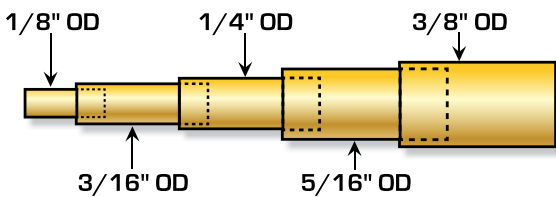

### COPPER BRAZE TEES

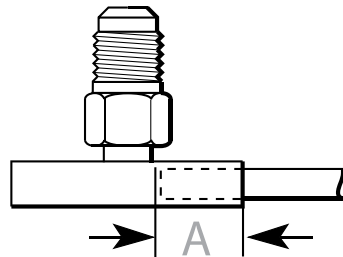

### COPPER ACCESS UNIONS

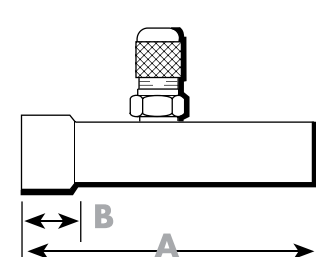

### 3/16" OD FIT

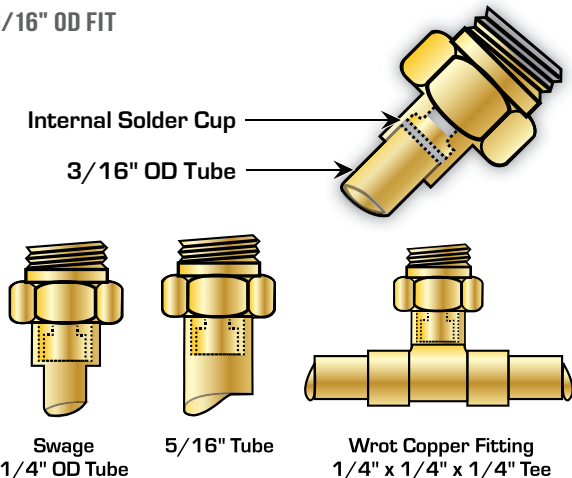

### NOMENCLATURE

For easy reference, the last two numerals of our flare fittings correspond to their respective tube sizes.

NOMENCLATURE			
NUMBER	TUBE SIZE	NUMBER	TUBE SIZE
02	1/8"	08	1/2"
03	3/16"	10	5/8"
04	1/4"	12	3/4"
05	5/16"	14	7/8"
06	3/8"	18	1 1/8"

## JB INDUSTRIES ACCESS VALVES SPECIFICATIONS

ARI STANDARD	720-2002
ARI TORQUE	3.0 - 5.0 inches/pound
TEMP RANGE	-40° F to 250° F (-40° C to 121° C)
VALVE BODIES	Brass
VALVE CORE	Stainless steel and brass for use with all refrigerants such as R-12, R-22, R-134a, R-410A, and R-502. Resistant to oils, alkalites, and diluted mineral acids

## COPPER TUBE EXTENSIONS

Use these fittings with Sil-phos alloy and copper fittings. Install through the side of the larger line to extend length approximately two inches. Includes cap (NFT5-4) and valve core. 1/4" ID.

- GENEROUS COUNTER BORE ALLOWS REMOVAL OF CORE IF FLARE BECOMES DAMAGED.
- ALL TEES AND CROSSES ARE TAPPED TO RECEIVE AN ACCESS CORE IN ALL 1/4" SAE FLARE ENDS.
- ALL PIPE CONNECTIONS HAVE INTERNAL BRAZE CUPS FOR DIP TUBE APPLICATIONS.
- ALL VALVES ARE EQUIPPED WITH CAP AND ONE VALVE CORE (BRAZE TYPE LOOSELY ASSEMBLED).

### COPPER TUBE EXTENSIONS

PART NO.	QTY.	DESCRIPTION
A31002	5	1/8" OD
A31003	5	3/16" OD x 1/8" ID
A31004	5	1/4" OD x 3/16" ID
A31005	5	5/16" OD x 1/4" ID
A31006	5	3/8" OD x 5/16" ID
A31008	3	1/2" OD
A31004S	5	1/4" OD

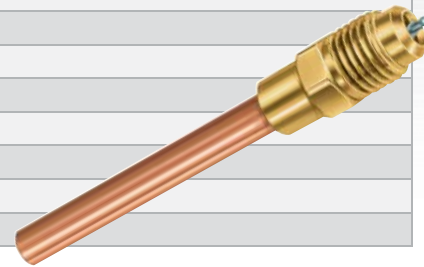

NOTE: OD x ID sizes are for copper tube extension. For connecting line size, see chart on page 52 for ODS and ODF fit.

## MULTI-STEP COPPER TUBE EXTENSION



### MULTI-STEP COPPER TUBE EXTENSION

PART NO.	QTY.	DESCRIPTION
A31009	5	1/8" OD ext; 3/16", 1/4" and 5/16" ODF body steps
A31011	3	3/16" OD ext; 1/4" and 3/8" ODF body step
A31012	3	1/8" OD ext.; 1/8" and 3/16" body step

## COPPER SADDLE BRAZE/TAPPER

The A32800 series of saddles offer the best protection from leaks. Once brazed on, you can check for leaks before piercing the tube. The steel pin is inserted and the cap is tightened down to pierce the tube. Body sizes are contoured to match specific tube sizes. The braze/tapper has a hardened steel-piercing needle and is furnished with a cap.

### COPPER BRAZE TAPPER ONLY

PART NO.	QTY.	DESCRIPTION
A32804	5	1/4"
A32805	5	5/16"
A32806	5	3/8"
A32808	3	1/2"
A32810	3	5/8"
A32812	2	3/4"
A32814	2	7/8"
A32818	2	1-1/8"

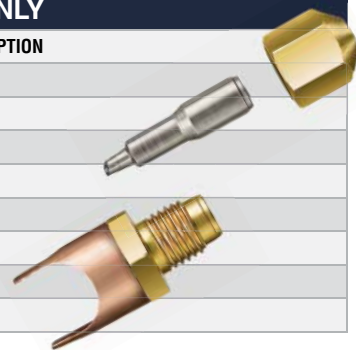

### COPPER BRAZE SADDLE WITH TAPPER

PART NO.	QTY.	DESCRIPTION
A32904	5	1/4"
A32905	5	5/16"
A32906	5	3/8"
A32908	3	1/2"
A32910	3	5/8"
A32912	2	3/4"
A32914	2	7/8"



ACCESS VALVES



100% American brass sourced from US mills

# ACCESS VALVES



100% MADE IN USA



## SWIVEL FLARE CONNECTIONS

ADD MULTIPLE PORTS WITH JUST ONE FITTING

These valves offer a safe, simple installation without the need for brazing. All of the flare ends are tapped to receive access cores. JB provides a full range of various end configurations to provide greater flexibility. One core and cap are packaged with each valve.

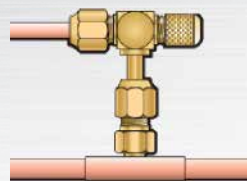

### SWIVEL FLARE W/CORE DEPRESSOR

- ADD A NEW LINE OR CONTROL
- NO REFRIGERANT LOSS ON CHARGED SYSTEM

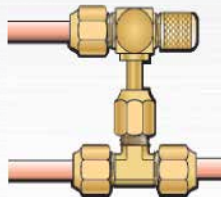

### SWIVEL FLARE W/OUT CORE DEPRESSOR

- MULTIPLE PORTS
- ADDITIONAL LINE OR CONTROLS
- ADDITIONAL ACCESS SITE

**A31851**  
SWIVEL TEE  
W/DEPRESSOR



### SWIVEL TEE WITH DEPRESSOR

PART NO.	QTY.	DESCRIPTION
A31851	3	1/4" Female SAE swivel nut on run
A31852	3	1/4" Female SAE swivel nut on branch



**A31854**  
SWIVEL TEE

### SWIVEL TEE WITHOUT DEPRESSOR

A31854	3	1/4" Female SAE swivel nut on branch
A31864	3	1/4" Female SAE swivel nut on run

**A31853**  
SWIVEL 3/8"  
SAE TEE



### SWIVEL 3/8" SAE TEE

A31853	1	3/8" SAE x 3/8" Female SAE swivel nut x 1/4" access
A31856	1	3/8" SAE x 1/4" access x 3/8" Female SAE swivel nut



**A33004**  
1/4" SAE SWIVEL  
FLARE

### ACCESS VALVE COUPLER WITH DEPRESSOR

A33004	1	1/4" SAE swivel flare x male flare
--------	---	------------------------------------

**A31434**  
BULKHEAD  
MOUNTING



## BULKHEAD MOUNTING

### BULKHEAD MOUNTING

*A31434	1	Access x 1/4" SAE w/nut
*A31727	1	Access x 3/16" & 1/4" ODS or 3/8" ODF

\*CORE PRE-TORQUED TO ARI



**A31520**  
1/4" SWIVEL NUT  
CROSS

## CROSSES

### SWIVEL CROSS WITH DEPRESSOR

A31520	1	1/4" Female SAE swivel nut x access
--------	---	-------------------------------------

### CROSS WITH THREE ACCESS PORTS

A31522	1	1/8" MPT cross
--------	---	----------------

**A31522**  
1/8" MPT  
CROSS



# ACCESS VALVES



100% MADE IN USA



## MPT CONNECTIONS

All MPT connections have internal braze cup for dip tube installation.

MPT CONNECTIONS		
PART NO.	QTY.	DESCRIPTION
A31482	5	1/8" MPT half union
A31484	5	1/4" MPT half union
A31492	3	1/8" MPT elbow
A31494	3	1/4" MPT elbow

MPT CONNECTIONS TEE		
A31452	3	1/8" MPT half union
A31454	3	1/4" MPT half union
A31512	3	1/8" MPT run
A31514	3	1/4" MPT run

FORGED BRASS BRAZE TEES		
A31234	3	1/4" ODS x 3/8" ODF
A31235	3	5/16" ODS x 3/8" ODF
A31236	3	3/8" ODS x 1/2" ODF
A31238	3	1/2" ODS x 5/8" ODF

FLARED TUBE CONNECTION		
*A31424	3	1/4" Female SAE union w/flare nut
A31444	3	1/4" Female SAE union w/flare nut

\*CORE PRE-TORQUED TO ARI

FLARE CONNECTION & FLARE FITTING ADAPTER		
*A31614	5	1/4" Female SAE w/copper gasket
*A31734	3	1/4" Female SAE swivel nut w/depressor

\*CORE PRE-TORQUED TO ARI

BRASS BODIES		
A31722	3	1/8" ODS x 1/4" ODF
A31723	3	3/16" ODS x 1/4" ODF
A31724	3	1/4" ODS x 3/8" ODF
A31725	3	5/16" ODS x 1/2" ODF
A31726	3	3/8" ODS x 1/2" ODF
A31728	3	1/2" ODS x 5/8" ODF

MULTI STEP		
A31720	5	3/16" ODS x 1/4" or 3/8" ODF steps
A31729	3	3/16", 1/4", 5/16", 1/2" ODF steps
A31736	3	1/8" ODS x 3/16", 1/4" or 5/16" ODF

**A31722**  
1/8" ODS X 1/4" ODF  
BRASS BODY



**A31720**  
3/16" ODS X  
1/4" STEPS

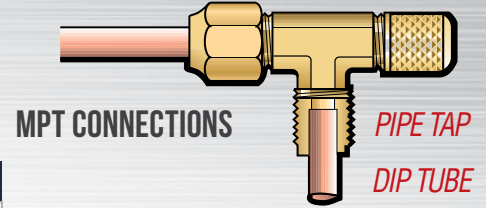

MPT CONNECTIONS

PIPE TAP  
DIP TUBE



**A31482**  
1/8" MPT HALF  
UNION

**A31452**  
1/8" MPT HALF  
UNION TEE

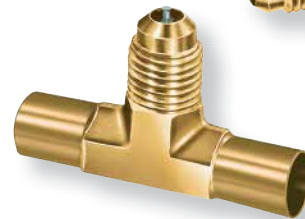

**A31234**  
1/4" ODS X 3/8"  
ODF BRASS TEE

**A31424**  
1/4" SAE UNION  
W/FLARE NUT



**A31734**  
1/4" SAE  
SWIVEL NUT  
W/DEPRESSOR



ACCESS  
VALVES

# ACCESS VALVES

## SAE 45° BRASS FLARED TUB FITTINGS

**A32600**  
1/4" SAE 45°  
TUBE FITTING



### SAE 45° BRASS FLARED TUBE FITTINGS



PART NO.	QTY.	DESCRIPTION
A32600	10	1/4" (NS4-4)
A32601	5	5/16" (NS4-5)
A32602	10	3/8" (NS4-6)
A32603	5	1/2" (NS4-8)
A32604	5	5/8" (NS4-10)
A32605	2	3/4" (NS4-12)



**A32700**  
1/4" X 1/4" SWIVEL  
FLARE X SOLDER

### SWIVEL FEMALE FLARE X SOLDER ADAPTER



PART NO.	QTY.	DESCRIPTION
A32700	4	1/4" x 1/4" (US5-44)
A32701	4	3/8" x 3/8" (US5-66)
A32702	4	1/2" x 1/2" (US5-88)
A32703	2	5/8" x 5/8" (US5-1010)
A32704	2	3/4" x 3/4" (US5-1212)

## JB INDUSTRIES ACCESS VALVE SERVICE KIT

JB has taken the most popular access fittings used on service calls and created an access valve service kit with convenient storage case. Each kit is compartmentalized to house the following: A31002, A31003, A31004, A31005, A31006, NFT5-4, A31851, A31852, A32004 valve core tool with cores, A31998 plastic core removers, and A33500 thumbscrew core depressor. The interior of the label includes part numbers to make individual reordering and stocking convenient.



**AVK-001**  
ACCESS VALVE  
SERVICE KIT



### AVK-001 ACCESS VALVE SERVICE KIT

PART NO.	DESCRIPTION
AVK-001	Access valve service kit in storage case
A31002 (x3), A31003 (x3), A31004 (x3), A31005 (x3), A31006 (x3), NFT5-4 (x6), A31851 (x1), A31852 (x1), A32004 (x1), A31998 (x3) and A33500 (x1)	

## BULK FITTING JARS

JB has taken a few of the best selling access valves and packaged them in a convenient display jar. Featuring individual labels with unique bar codes, the item can be scanned at the top of the jar rather than looking it up in the computer. Saves counter personnel time to directly sell single units without having to look up part numbers in the system. Order the jar once and restock as needed.

**A31004-CJ**  
BULK A31004  
COPPER TUBE  
EXTENSION



### BULK FITTING JARS

PART NO.	QTY.	DESCRIPTION
A31004-CJ	250	1/4" OD x 3/16" ID copper tube extension with bulk jar
NFT5-4-CJ	500	1/4" SAE cap with bulk jar



# ACCESS VALVES

## EVACUATION & CORE REMOVER TOOLS

Specifically designed to valve off the system to remove valve core, these tools feature a quarter turn ball valve shut-off and O-ring seals.

The valve core can be completely removed and replaced without losing system charge. Speed-up evacuation, recovery, or recharging time through the full flow port. Both tools have a storage area to house spare valve cores.

### VACUUM RATED

(QC) QUICK CONNECT



**A32525N**  
1/4" VALVE CORE  
REMOVER TOOL



SIDE PORT

FLARE RUN

### VALVE CORE REMOVER TOOL

PART NO.	QUICK CONNECT	FLARE RUN	SIDE PORT
A32500N	1/4"	1/4"	---
A32505N	5/16"	1/4"	---
A32525N	1/4"	1/4"	1/4"
A32530N	5/16"	1/4"	1/4"
A32535N	5/16"	5/16"	1/4"
A32501N	Core remover bit for A32500N replacement		
A32504	Core remover bit for A32525N replacement		

## EVACUATION RECOVERY TOOL

Our evacuation/recovery tool is a plier-type tool with a quick release trigger which punctures large holes into the line for discharge of a recovery unit. Fits 3/16" to 7/8" OD hard tubing.

**A32100**  
EVACUATION/  
RECOVERY TOOL



### EVACUATION RECOVERY TOOL

PART NO.	QTY.	DESCRIPTION
A32100	1	Evacuation/recovery tool
A32101	1	Hardened steel needle and gasket

## VALVE CORE TORQUE TOOL

Our valve core torque tool automatically sets proper torque to 5" pounds. Calibrated to precise torquing requirements for core valves, the tool will no longer tighten once proper torque is achieved. Eliminates guess work which results in under and over torquing. Works with all Schrader valve cores.

**A32008-BX**  
BOX OF VALVE  
CORE TORQUE  
TOOLS



**A32008**  
VALVE CORE  
TORQUE TOOL

### VALVE CORE TORQUE TOOL

PART NO.	QTY.	DESCRIPTION
A32008	1	1/4" Valve core torque tool
A32008-B	12	1/4" Valve core torque tool bulk
A32008-BX	12	1/4" Valve core torque tool in display box

## 1/4" VALVE CORES & TOOL

PTFE/neoprene seal replacement valve core. Max 800 psi and 220°F (104°C).

**A32004**  
VALVE CORE  
TOOL



**A31999**  
1/4" VALVE CORE

### 1/4" VALVE CORES & TOOL

PART NO.	QTY.	DESCRIPTION
A32004	1	1/4" Valve core tool with storage for 6 valve cores
A31999	5	1/4" Valve cores
A31999-25	25	1/4" Valve cores
A31999-100	100	1/4" Valve cores

ACCESS VALVES

# CAPS

100% MADE IN USA



## O-RING QUICK SEAL CAPS

Deep Vacuum and A/C Refrigeration. Finger-tight sealing for all male SAE connections.

NFT5-4



### O-RING QUICK SEAL CAPS

PART NO.	QTY.	DESCRIPTION
NFT5-4	10	1/4" SAE cap
NFT5-5	3	5/16" SAE cap
NFT5-6	3	3/8" SAE cap
NFT5-8	3	1/2" SAE cap
NFT5-4-100	100	1/4" SAE cap
NFT5-6-100	100	3/8" SAE cap
P90010	10	Replacement 1/4" O-ring
P90011	10	Replacement 3/8" O-ring

## QUICK SEAL GASKET CAPS

Deep Vacuum and A/C Refrigeration. Finger-tight sealing for all male SAE connections.

A31985



### QUICK SEAL GASKET CAPS

PART NO.	QTY.	DESCRIPTION
A31985	10	1/4" SAE cap
A31985-100	100	1/4" SAE cap
P509	6	Replacement gasket
P509-25	25	Replacement gasket

## O-RING SEAL LINE PIERCING

Our spring loaded needle automatically back-seats, forming a leak proof seal. A simple installation that is 100% restriction-free. Both models fit 1/4", 5/16", 3/8", 1/2", and 5/8" OD tubing.

LT-456



### O-RING SEAL LINE PIERCING

PART NO.	DESCRIPTION
LT-456	1/4" – 3/8" Line piercing valve
LT-810	1/2" – 5/8" Line piercing valve

## E-Z TAPPER

The back-seating stem eliminates line restriction when servicing through access port or when using the valve for flow control.

EZ-40288



### E-Z TAPPER

PART NO.	QTY.	DESCRIPTION
EZ-40288	1	E-Z tapper piercing valve
EZ-40288-126	5	E-Z tapper gasket

## WRENCH STYLE SEAL CAP

For A/C Refrigeration service. Brass to brass positive seal and permanent installation.

A31986



### WRENCH STYLE SEAL CAP

PART NO.	QTY.	DESCRIPTION
A31986	5	1/4" SAE cap

## BACK-SEATING CONTROL VALVE

A33000

Ideal for use on pre-charged line sets. Eliminates spraying of leak detection dye and refrigerant. Compact brass body for long service. Swivel coupler with double safety grooves.



### BACK-SEATING CONTROL VALVE

PART NO.	QTY.	DESCRIPTION
A33000	1	1/4" SAE x 1/4" O-ring quick coupler
P90009	10	Replacement O-ring

## EVACUATION RECOVERY TOOL

A31997 is a 1/4" SAE gasket seal cap with core remover feature. A31998 is a 1/4" plastic core remover.

A31997



A31998



### EVACUATION RECOVERY TOOL

PART NO.	QTY.	DESCRIPTION
A31997	10	1/4" SAE gasket seal caps with core removers
A31998	5	1/4" Plastic core removers

## SPECIALTY CAPS AND 1/2" 16 ACME CAPS

A31992



### SPECIALTY CAPS AND 1/2" 16 ACME CAPS

PART NO.	QTY.	DESCRIPTION
A31992	5	1/4" SAE cap
A31992-100	100	1/4" SAE cap
13493	2	Plastic cap with retainer strap
13494	1	Plastic cap

# COUPLERS

## QUICK COUPLERS

### QC-S5

5/16" female x 1/4" male adapter is designed to give the end user the ability to connect their standard refrigeration hoses to 5/16" (1/2" UNF) fittings being used on most R-410A mini-splits. Swiveled so the adapter can remain on hoses for easy on/off application and installation.

### 3/8" COUPLERS:

- PATENTED O-RING SEAL FOR DEEP VACUUM
- NO DEPRESSOR

### 5/16" COUPLERS:

- FOR 410A CONNECTIONS
- VALVE CORE DEPRESSOR
- SAFETY CHANNELS
- RUBBER GASKET SEAL

### 3/16" COUPLERS:

- VALVE CORE DEPRESSOR
- SAFETY CHANNELS
- O-RING SEAL

### 1/4" COUPLERS:

- VALVE CORE DEPRESSOR
- SAFETY CHANNELS
- RUBBER GASKET SEAL

### STRAIGHT

PART NO.	QTY.
QC-S3	3/16" QC x 1/4" SAE
QC-S4	1/4" QC x 1/4" SAE
QC-S46	1/4" QC x 3/8" SAE
QC-S5	5/16" QC x 1/4" SAE
QC-S5S	5/16" QC x 1/4" SAE (no depressor)
QC-S64	3/8" QC x 1/4" SAE (no depressor)
QC-S65	3/8" QC x 5/16" SAE (no depressor)



### FEMALE NPT THREAD

QC-S4A	1/4" QC x 1/8" Female NPT
QC-S4B	1/4" QC x 1/4" Female NPT

### ELBOW

QC-E3	3/16" QC x 1/4" SAE elbow
QC-E4	1/4" QC x 1/4" SAE elbow
QC-E5	5/16" QC x 1/4" SAE elbow
QC-E64	3/8" QC x 1/4" SAE elbow (no depressor)



### SAE FEMALE ADAPTER

A31656	1/4" SAE Male x 5/16" SAE Female Adapter
A31665	5/16" SAE Male x 1/4" SAE Female Adapter

### QUICK COUPLER ACCESS TEE

O-ring seal quick coupler. Furnished with cap and valve core.

A34000



### QUICK COUPLER ACCESS TEE

PART NO.	QTY.	DESCRIPTION
A34000	1	1/4" QC x 1/4" access branch tee
P90009	10	Replacement O-ring

CV-20004



### SWIVEL CYLINDER VALVE

PART NO.	QTY.
CV-20004	3/4" NPS x 1/4" M flare
CV-20006	3/4" NPS x 3/8" M flare

A33500



### CORE DEPRESSOR

A33500	1/4" Thumbscrew core depressor
--------	--------------------------------

### REPLACEMENT PARTS FOR QUICK COUPLERS

P90009	10	Replacement O-ring
P509	6	1/4" Gasket
P90513	5	Depressor for 1/4" QC
P90012	10	3/8" O-ring

ACCESS VALVES

## LIQUID CHARGING ADAPTERS

Metering element reduces liquid flow to a level below capacity of compressor. This assures a safe, fast charge without damaging the compressor. Accepts liquid refrigerant from the cylinder and discharges into low side of the system. Liquid charging is recommended when charging blends into refrigeration and air conditioning systems, and a liquid charger adapter is necessary for safe and fast liquid charging through the low side of a system. Eliminates the time and effort of heating cylinders.



### LIQUID CHARGING ADAPTERS

LC-4	1/4" Liquid charging adapter
LC-5	5/16" Liquid charging adapter

# REFRIGERANT BALL VALVES

## FULL FLOW BALL-REFRIGERATION

JB's ball-refrigeration valves have a large port design that provides a minimum pressure drop with straight through flow. Copper end fittings reduce installation time without disturbing valve. We have two types of ball valves to suit your needs. Our traditional ball valves have brass actuators and a working pressure rating of 500 psi. Our new addition ball valve features stainless steel actuators and a working pressure rating of 700 psi. We differentiate the two types here by "Apollo" and "E-Line." Both are UL listed.

### BALL VALVE BREAKDOWN

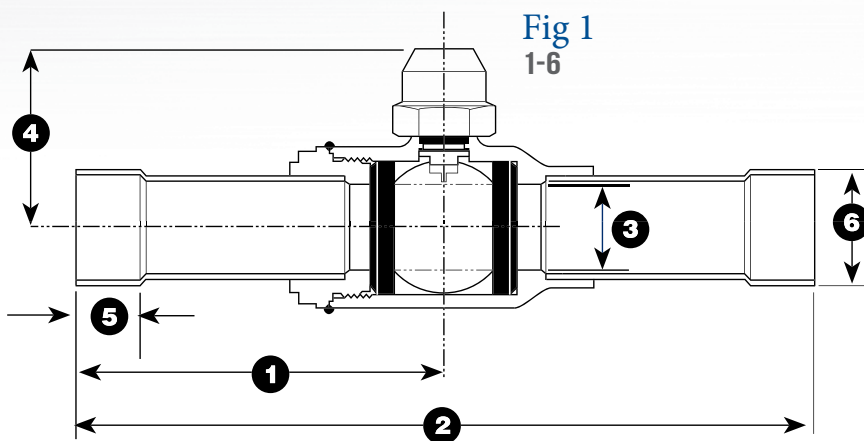

**Fig 2**  
A-B

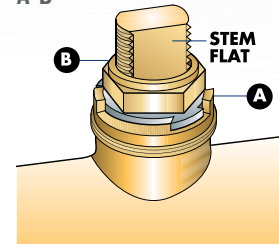

**FIG 2 - BALL VALVE OPERATION**

- A. Quarter turn mechanical stop. Positive open and closed positions.
- B. Packing gland adjusting nut

**Fig 3**  
A-I

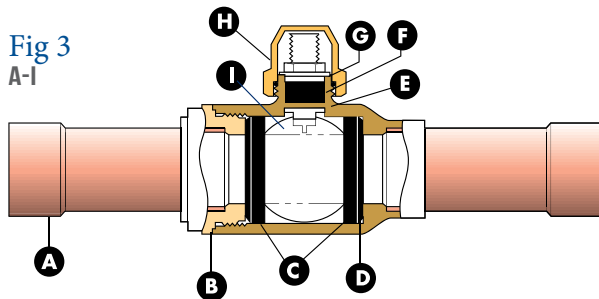

**FIG 3 - ANATOMY OF A BALL VALVE**

- A. Copper tube extensions
- B. Hermetic welded & brazed joints
- C. Reinforced Teflon seats
- D. One piece forged brass body
- E. Bearing washer
- F. Changeable reinforced PTFE stem packing
- G. Packing gland
- H. Stem cap assembly with neoprene seal
- I. Chromium plated ball with vented valve

### APOLLO FULL FLOW REFRIGERANT BALL VALVES

### PRESSURE TO 500 PSI UL LISTED 57R7

PART NO. WITHOUT PORT	PART NO. WITH PORT	OD (FIG 1: 6)	FIG 1: 1	FIG 1: 2	FIG 1: 3	FIG 1: 4	FIG 1: 5
V34200	V34400	3/8"	3.18"	6.09"	0.30"	1.55"	3/8"
V34201	V34401	1/2"	3.18"	6.09"	0.45"	1.55"	3/8"
V34202	V34402	5/8"	3.43"	6.59"	0.50"	1.55"	1/2"
V34203	---	3/4"	3.45"	7.27"	0.69"	1.89"	3/4"
V34204	V34404	7/8"	3.69"	7.07"	0.75"	1.83"	3/4"
V34206	V34406	1 1/8"	4.20"	8"	1"	2.01"	2 9/32"
V34207	V34407	1 3/8"	4.54"	8.63"	1.25"	2.61"	3 1/32"
V34208	V34408	1 5/8"	4.47"	8.85"	1.50"	2.79"	1 3/32"
V34209	V34409	2 1/8"	4.84"	9.59"	2"	3.17"	1 11/32"
V34210	---	2 1/8"	5"	10"	2.43"	3.90"	1 31/64"
V34211	---	3 1/8"	7"	14"	2.50"	3.90"	1 43/64"

# REFRIGERANT BALL VALVES

## APOLLO ACTUATORS

PRESSURE TO 500 PSI, UL LISTED 57R7

- UP TO +500° F WORKING TEMPERATURE AT 0 PSI
- UP TO +300° F WORKING TEMPERATURE AT 500 PSI
- NO BOLTED OR SCREWED BONNETS OR FLANGES TO LEAK
- APOLLO REGISTERED TO ISO 9001



**V34202**  
5/8" OD APOLLO  
ACTUATOR



## E-LINE ACTUATORS

PRESSURE TO 700 PSI, UL LISTED 32DC

- NO BOLTED OR SCREWED BONNETS OR FLANGES TO LEAK

**V34307**  
1-3/8" OD E-LINE  
ACTUATOR



## REFRIGERATION SHUT-OFF BALL VALVES

Ideal for building your own vacuum or charging system, our straight through flow design has no restriction. A quarter turn and the valve is fully open or closed.

### REFRIGERATION SHUT-OFF BALL VALVES

PART NO.	DESCRIPTION
V34900	1/8" Female NPT x 1/8" Female NPT
V34901	1/4" SAE x 1/8" MPT
V34905	1/4" SAE x 1/4" MPT
V34010	3/8" Female NPT x 3/8" Female NPT

## NEEDLE VALVES

The packing used in the needle seat valves is resistant to gasoline, oils, and water while providing excellent sealing characteristics over the life of the valve. Metal to metal seating provides ease in shut-off to working pressures of 105 psi.

### NEEDLE VALVES

PART NO.	DESCRIPTION
NV62-4	1/4" COMP x 1/4" COMP

ACCESS  
VALVES

## E-LINE FULL FLOW REFRIGERANT BALL VALVES

PRESSURE TO 700 PSI UL LISTED 32DC

PART NO. WITHOUT PORT	PART NO. WITH PORT	OD (FIG 1: 6)	FIG 1: 1	FIG 1: 2	FIG 1: 3	FIG 1: 4	FIG 1: 5
V34350	V34525	1/4"	3.25"	6.5"	0.50"	1.51"	3/8"
V34300	V34500	3/8"	3.18"	6.09"	0.30"	1.55"	3/8"
V34301	V34501	1/2"	3.18"	6.09"	0.45"	1.55"	3/8"
V34302	V34502	5/8"	3.43"	6.59"	0.50"	1.55"	1/2"
V34303	---	3/4"	3.45"	7.27"	0.69"	1.89"	3/4"
V34304	V34504	7/8"	3.69"	7.07"	0.75"	1.83"	3/4"
V34306	V34506	1 1/8"	4.20"	8"	1"	2.01"	2 9/32"
V34307	V34507	1 3/8"	4.54"	8.63"	1.25"	2.61"	3 1/32"
V34308	V34508	1 5/8"	4.47"	8.85"	1.50"	2.79"	1 3/32"
V34309	V34509	2 1/8"	4.84"	9.59"	2"	3.17"	1 11/32"
V34310	V34510	2 5/8"	5"	10"	2.43"	3.90"	1 31/64"
V34311	V34511	3 1/8"	7"	14"	2.50"	3.90"	1 43/64"

# TUBING TOOLS

## 24 MONTH WARRANTY

## JB INDUSTRIES & ROTHENBERGER

The partnership of ROTHENBERGER and JB brings together the best of German engineering and European craftsmanship with American distribution to create the highest quality tools in the HVAC/R marketplace.

ROTHENBERGER tools are made of the highest quality materials and to the strictest quality standards to ensure that these tools will not fail when you need them the most. We have seen a tremendous growth and acceptance in the marketplace. Once you get your hands on these tools, you can immediately feel the quality and see why ROTHENBERGER tools are Just Better.

Should you not see a particular tool of interest, please contact us at **800.323.0811** or email us at [sales@jbind.com](mailto:sales@jbind.com). The entire ROTHENBERGER product line and technical features can be viewed at [www.jbind.com](http://www.jbind.com).

### MINI TUBE CUTTERS

Used for cutting copper tubes, these mini tube cutters have a large knurled knob and handy design to produce fatigue-free pressure control.



**RT70105**  
COPPER MINICUT  
1/8" TO 7/8" OD

### PROFESSIONAL TUBE CUTTER

For tubes made out of copper, brass and aluminum, this tube cutter features a retractable deburrer blade and a spare cutter wheel in the handle. The smooth adjustment knob allows for quick adjustment.



**RT70027**  
1/4" TO 1-1/8" OD  
TUBE CUTTER

#### MINI TUBE CUTTERS

PART NO.	QTY.	DESCRIPTION
RT70401	1	Copper 1/8" to 5/8" OD
RT70402	1	Copper 1/4" to 7/8" OD
RT70105	1	Copper MINICUT 1/8" to 7/8" OD
RT70015	1	Copper MINI MAX 1/8" to 1 1/8" OD
RT70017B	2	Replacement cutter wheel
RT70017D	5	Replacement cutter wheel
RT70041	1	Replacement axle screw/pin

#### PROFESSIONAL TUBE CUTTER

PART NO.	QTY.	DESCRIPTION
RT70027	1	1/4" to 1 1/8" OD copper, brass & aluminum pipe
RT70029	1	1/4" to 1 1/8" OD copper, brass & aluminum pipe
RT21652B	10	Replacement deburring blade
RT70017B	2	Replacement cutter wheel
RT70017D	5	Replacement cutter wheel
RT70056D	5	Replacement cutter wheel for stainless steel

### ROTRAC PLUS

JB precision tube cutters for copper tube are manufactured by ROTHENBERGER for JB and designed with smooth-running telescopic action for a consistent working radius. Features include a protected screw spindle to shield against dirt and jamming, and a lightweight cast aluminum body. The deburrer swivels up, and a spare cutter wheel is stored in the handle, making them always within reach, each Rotrac Plus comes with a total of 3 spare cutter wheels.



**RT70020**  
1/8" TO 1-1/8" OD  
ROTRAC PLUS

### WATER PUMP PLIERS

Complies with DIN 5321 D, these pliers are made with heavy-duty box joint, chrome vanadium steel, drop forged, tempered, and polished head and joint. The longer, thinner pliers with measurements for corners are ideal for hard to reach places. The self-clamping jaws will not slip, even on smooth surfaces.



**RT70522**  
10" PLIERS MAX.  
1-1/4" OD

#### ROTRAC PLUS

PART NO.	QTY.	DESCRIPTION
RT70020	1	Copper tube 1/8" to 1 1/8" OD
RT70021	1	Copper tube 1/4" to 1 1/8" OD
RT70007B	2	Replacement cutter wheel
RT70007X	10	Replacement cutter wheel
RT99016	1	Replacement clip and axle



#### WATER PUMP PLIERS

PART NO.	DESCRIPTION
RT70521	7" Pliers Max. 1" OD
RT70522	10" Pliers Max. 1-1/4" OD
RT70523	12" Pliers Max. 1-1/2" OD

# TUBING TOOLS

## 24 MONTH WARRANTY

### RATCHET TUBE CUTTER

For copper, brass, aluminum, thin-walled steel, and plastic coated tubes, this ratchet tube cutter has a retractable internal deburring tool and spare cutter wheel in the handle so they are always within reach. The ratchet telescopic guide with automatic spring-driven withdrawal allows for quick adjustment and fast opening.

**RT70030**  
1/8" TO 2-5/8" OD  
RATCHET TUBE CUTTER



RATCHET TUBE CUTTER		
PART NO.	QTY.	DESCRIPTION
RT70030	1	1/8" to 2 5/8" OD
RT70142	1	2" to 5" OD
RT70017B	2	Replacement cutter wheel for RT70030
RT70017D	5	Replacement cutter wheel for RT70030
RT70057D	2	Replacement cutter wheel for RT70142
RT21652B	10	Replacement deburring blade pack

### PIPE SHEARS

For precise cutting of PVC, PP, PE, PEX, PB, CPVC and PVDF, our pipe shears are the finest you can find. The quick release lever provides automatic opening of the blade at the push of a button. A double-sided stainless steel blade with v-shaped edges pierce the pipe to prevent deformation. The wide pipe rest ensures a square cut every time. A locking lever secures the blade during transport.

**RT52010**  
MAX OD 2" PIPE  
SHEARS



PIPE SHEARS		
PART NO.	QTY.	DESCRIPTION
RT52000	1	Max. OD 1 5/8", Sched. 40 PVC 1-1/4"
RT52010	1	Max. OD 2", Sched. 40 PVC 1-1/2"
RT52011	1	Replacement blade for RT52010
RT52030	1	ROCUT® 63TC, Max. OD 2-1/2"
RT52042	1	Replacement blade for RT52000

### ROLOCK

Professional-grade water pump pliers with a jaw locking system providing a secure grip on round, square, or hex-shaped items with a push of a button.

The ROLOCK has 14 groove opening positions with an opening capacity of 21/3".

**RT70533**  
12' ROLOCK

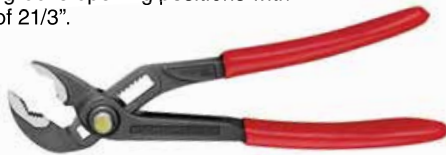

ROLOCK		
PART NO.	QTY.	DESCRIPTION
RT70531	1	ROLOCK 7"
RT70532	1	ROLOCK 9"
RT70533	1	ROLOCK 12"

### DEBURRING TOOLS

Internal/External deburring tools for copper and plastic tubes.



**RT21655**  
DEBURRING  
TOOL

**RT70075**  
COPPER & STAINLESS  
STEEL REAMER

**RT11006**  
COPPER & STAINLESS  
STEEL REAMER

DEBURRING TOOLS		
PART NO.	QTY.	DESCRIPTION
RT11006	1	Copper and stainless steel internal/external reamer 1/8" to 1 5/8" OD
RT70075	1	Copper and stainless steel internal/external reamer 1/8" to 2" OD
RT21660	1	Deburring tool (blade non-replaceable)
RT21655	1	Deburring tool
RT21652B	10	Replacement deburring blade (10 pack)

### RO-GRIP RT70558

With a perfect grip and better leverage, our self-adjusting pliers offer many advantages over conventional pliers. Made of drop forged chrome vanadium steel, the rhombus-shaped jaws securely grab round, hex, sheets, and other shapes up to 15/8" OD.



### MINIBEND® TUBE BENDER

RT25151

For exact, two-handed bending up to 180° for tubes made out of soft copper, brass, aluminum, and precision steel. 1/4", 5/16", and 3/8" OD.



TOOLS & ACCESSORIES

# TUBING TOOLS

## HAND TUBE BENDER

RT90614

This universal hand bender provides bending of 1/2", 5/8", 3/4" and 7/8" OD soft copper, aluminum, and light grade stainless steel tubing.



## STANDARD TUBE BENDER PRO

For exact bending radius up to 180° for tubes made up of soft copper, aluminum, and precision steel. The light construction results in fatigue-free hand operation. The clamp mechanism better holds the tube and enables the bending of even the shortest of tube pieces. The Tube Bender Pro is for 1/2" and 3/4" semi-hard and hard copper pipes and features a case iron body for longer life along with self adjusting shoe.

RT25140  
1/4" OD RADIUS



### STANDARD TUBE BENDER PRO

PART NO.	DESCRIPTION
RT25140	1/4" OD radius (0.71")
RT25131	5/16" OD radius (0.95")
RT25913	Tube Bender Pro 1/2" OD radius
RT25914	Tube Bender Pro 3/4" OD radius
RT25142	1/2" OD radius
RT25136	5/8" OD radius (2.28")

## MAXI TUBE BENDER SET

RT23022

The smooth-running feed lever of this tube bender makes it ideal in restricted spaces and one-handed operations. The side lever allows for quick release and reset of bending former. The pliers feature a bayonet catch to easily change bending formers. The open bending frame makes it possible to repeatedly produce alternate angled bends. The set consists of the basic tool, bending support, bending formers, and steel case. For use on copper and soft aluminum 3/8", 1/2", 5/8", 3/4", and 7/8" OD.



## TORQUE WRENCH KITS WITH INTERCHANGEABLE WRENCH HEADS

TRQ1080

- TORQUE RANGE OF 7.375 - 59.004 POUND-FEET OR 10-80 NM
- 6 SPANNER HEADS: 17, 22, 24, 26, 27 & 29mm
- 1/2" DR RATCHET HEAD
- PERFECT FOR SERVICING R-410A MINI SPLITS
- INCLUDES CONVENIENT CARRYING CASE



TRQ-IMP

- IMPERIAL SPANNER HEADS FOR TRQ1080 TORQUE WRENCH
- 4 SPANNER HEADS: 5/8", 13/16", 15/16" & 1-1/8"



TRQ1075

- TORQUE RANGE OF 10-75 NM
- 6 SPANNER HEADS: 17, 22, 24, 26, 27 & 29MM
- PERFECT FOR SERVICING R-410A MINI SPLITS
- INCLUDES CONVENIENT CARRYING CASE



## FIN STRAIGHTENERS

T20351

FOR 8, 9, 10, 12, 14, AND 15 SPACINGS PER INCH.



T20352

STAINLESS STEEL FIN STRAIGHTENER



T20353

STAINLESS STEEL FIN STRAIGHTENER WITH LARGER, EASY TO GRIP HANDLE.





# TUBING TOOLS

## FLARING TOOLS

FLARING TOOLS	
PART NO.	DESCRIPTION
T20195	3/16", 1/4", 5/16", 3/8", 7/16", (Nom: 1/8", 1/4", 3/8" & 1/2")
T20203	5/8", 3/4", 7/8", and 1-1/8" OD
T20500	3/16", 1/4", 5/16", 3/8", 1/2", and 5/8" OD
T30600	Eccentric cone type flaring tool: 3/16", 1/4", 5/16", 3/8", 1/2", 5/8", 3/4"
RT222402	1/8", 1/16", 1/4", 5/16", 3/8", 1/2", 5/8", 3/4" OD
RT222601	Adjustable from 3/16" to 5/8" OD

### RATCHETING FLARE TOOL

T30600

- ECCENTRIC CONE FLARING FOR TUBES WITH AN OD OF: 3/16", 1/4", 5/16", 3/8", 1/2", 5/8" & 3/4"
- INTERNAL CLUTCH PREVENTS OVER-TORQUING
- PERFECT FOR SERVICING 410A MINI SPLITS



### 45° FLARING TOOL

RT26036

For making precise 45° flares on copper, brass, aluminum, and precision steel tubes up to 0.04" (1 mm) in wall thickness. The special screw thread allows proper, efficient handling of material. The "Multi-block" multi-clamping calipers provide a firm, quick off-center clamping of the tube and automatic self-centering. Flares 3/16", 1/4", 5/16", 3/8", 1/2", and 5/8".

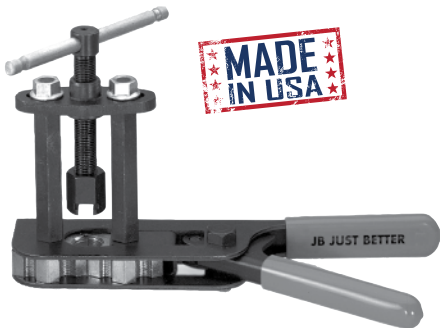

### TUBE EXPANDER KIT

RT12318

The high strength, forged aluminum body make for lower weight and easy handling of our expander set. The longer lever arms reduce effort and the automatic pin guide retracts for faster operation. The set includes expander with riveted expander heads in 3/8", 1/2", 5/8", 3/4", 7/8", and 1-1/8", internal/external deburring tool, steel case. Replacement heads are interchangeable with Yellow Jacket and Rigid tube expanders.



### SWAGING KIT

RT26715

For precise 45° single flares and sockets on copper, brass, aluminum, and steel tubes. Set includes flaring tool, 45° cone, expander pin, internal/external deburrer, tube cutter, and plastic case. Includes swages for 3/16", 1/4", 5/16", 3/8", 1/2", and 5/8".



### TEE EXTRACTOR SET

RT22124

Extract your own tees on soft, semi-hard and hard copper or aluminum to save time and money on T-pieces. The ergonomic, compact design fits into the tightest spaces. The set includes tee-extractors for 1/2", 5/8", 7/8" and 1-1/8", ratchet handle, cam pincer, high-speed drill, and steel case.



### ROPRESS TOOLS

FOR JB'S FULL LINE OF ROTHENBERGER TOOLS INCLUDING ROPRESS CRIMPING TOOLS VISIT OUR WEBSITE AT [WWW.JBIND.COM](http://WWW.JBIND.COM)



RT16101  
CORDED AND  
CORDLESS PRESS  
TOOL

STATE OF THE ART  
CRIMPING TOOLS  
COMPATIBLE WITH  
VIEGA, ELKHART,  
& NIBCO



RT16001  
COMPACT CORDLESS  
PRESS TOOL

TOOLS &  
ACCESSORIES

# TUBING TOOLS

## SPRING TYPE TUBE BENDER & SINGLE SPRINGS

Ideal for irregular bends, these spring type benders are available in single springs and packaged sets. Used for soft copper, aluminum, brass, and steel.

**BS-55**  
SPRING-TYPE  
TUBE BENDER



## SINGLE SIZE SWAGE SIZE STAMPED OD AND NOMINAL

**T21024**  
PACKAGED  
SWAGE SET



### SPRING TYPE TUBE BENDER

PART NO.	DESCRIPTION
BS-55	1/4", 5/16", 3/8", 1/2", and 5/8" in pouch
BS-77	All seven sizes in pouch

### SINGLE SPRINGS

PART NO.	TUBE OD	NOM
BS-4	1/4"	1/8"
BS-5	5/16"	-----
BS-6	3/8"	1/4"
BS-7	7/16"	-----
BS-8	1/2"	3/8"
BS-10	5/8"	1/2"
BS-12	3/4"	5/8"

### SINGLE SIZE SWAGE SIZE STAMPED OD AND NOMINAL

PART NO.	TUBE OD	NOM
T21002	1/8"	---
T21003	3/16"	---
T21004	1/4"	1/8"
T21005	5/16"	---
T21006	3/8"	1/4"
T21007	7/16"	---
T21008	1/2"	3/8"
T21010	5/8"	1/2"
T21012	3/4"	5/8"
T21014	7/8"	3/4"
T21018	1-1/8"	1"
T21024	Packaged Set: 1/4", 3/8", 1/2", & 5/8"	Packaged Set: 1/8", 1/4", 3/8", & 1/2"

## MULTI-SWAGE T21000

T21000 consists of three pieces that work with OD sizes including 3/16", 3/4", and 7/8" producing perfect solder cups for 9 OD tube sizes. OD sizes are 3/16", 1/4", 5/16", 3/8", 7/16", 1/2", 5/8", 3/4", and 7/8". Nominal 1/8", 1/4", 3/8", 1/2", 5/8", and 3/4".

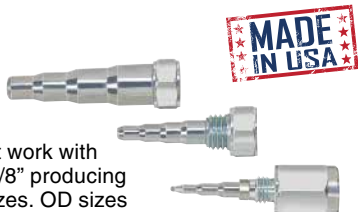

## MULTI-SWAGE T20095

Handy all-in-one tool. T20095 is a single piece that works with 1/4", 5/16", 3/8", 7/16", 1/2", and 5/8" OD.



## PINCH-OFF TOOL T21294

This plier-type pinch-off tool temporarily closes off line while making repairs. The quick release trigger and rounded jaws prevent cutting while allowing for reopening and rounding using a standard flare bar. For 1/8" to 5/8" OD (1/8" to 1/2" Nominal).



## 45° FLARE/SWAGE T20275

Heavy-duty wide-range bar-type flaring tool. The rugged, forged steel slip-on self centering yoke has a hardened chrome plate swivel-type cone to form quality flares with minimal effort. Hardened bars provide positive clamping action with minimum distortion and are fully hinged with king-sized forged steel wing nuts for easy use.

The second bar extends our flaring tool to 9 OD tube sizes.



### 45° FLARE/SWAGE T20275

T20275	<b>Flare:</b> 1/8", 3/16", 1/4", 5/16", 3/8", 7/16" and 3/4"	<b>Nominal Flare:</b> 1/8", 1/4", 1/2", and 5/8"
	<b>Swage:</b> 3/16", 1/4", 5/16", 3/8", 1/2", 5/8" and 3/4"	<b>Nominal Swage:</b> 1/8", 1/4", 3/8", 1/2", and 5/8"

# TUBING TOOLS

## BRAZE-RITE ADAPTER

BRZ-1000

Nitrogen purging adapter for AC/R pipe. Quickly connects to manifold gauge hose, and slips easily and securely into pipe. The BRZ-1000 allows for bleed of nitrogen through pipe being brazed, keeping the pipes clean and oxide-free. Stepped to fit most common AC/R pipe sizes, making it fast to go from one tube to the next. Saves time and money and helps maintain equipment manufacturer's system performance and installation guidelines. No more duct taping your hose to the pipe!

RANGE: 5/16" - 1-3/64"  
COPPER TUBE OD



## OIL TRANSFER PUMP

T30251

Designed to pump oil into the system while unit is operating without shutting down for charging. Smoothly pumps oil into the compressor on the down stroke while system is under pressure, resulting in easier pumping on the positive stroke. The universal tapered rubber adapter is designed to fit all 1, 2-1/2, and 5 gallon containers without additional adapters.

Works against 200 psi of pressure and is compatible with all oil types including synthetic, mineral, and polyol ester. Pumps 2.6 ounces (78 ml) per stroke.



## SERVICE WRENCHES

Double end reversible ratchet wrenches feature accurately broached multiple openings and offer the greatest number of uses in a single unit. Choose offset or hex and square ends. Items ending in "U" denote made in the USA.



T21127U  
SERVICE WRENCH



### SERVICE WRENCHES

PART NO.	DESCRIPTION
T21124U	3/16", 1/4" Square end and 1/2", 9/16" hex port end
T21127	1/4", 3/16" On one end 3/8", 5/16" on other end
T21127U	1/4", 3/16" On one end 3/8", 5/16" on other end
T21126U	Offset 1/4", 3/16" on one end 3/8", 5/16" on other end
T21125U	3/8" Square end and 1/2" square end

## GAS PRESSURE TEST KIT

This diaphragm gauge scale comes complete in case with hose and hook-up fitting.



29435  
NATURAL AND LP  
GAS PRESSURE TEST



### GAS PRESSURE TEST KIT

PART NO.	DESCRIPTION
29435	Natural and LP gases. Scales 0-20 oz/sq. in; 0-35" of water column
29436	Natural gas only. Scales 0-6 oz/sq. in; 0-10" of water column

## GAS TEST GAUGE

To test system pressure for leaks in new installs, use these 3-1/2" easy-to-read test gauges. Fits 3/4" and 1" pipes.



GTBG-12  
3-1/2" TEST GAUGE



### GAS TEST GAUGE

GTBG-12	3-1/2" Test gauge 0-30 lb. 3/4" end
GTBG-16	3-1/2" Test gauge 0-30 lb. 1" end

## HEX KEY ADAPTER

T2-HKA

Heat treated black oxide plated hex key adapter for accessing liquid and suction based valves. Works for 3/16" and 5/16" hex valves.



## STEEL STRAP

Our steel straps are zinc plated and alternate between nail and bolt holes.

PS-10  
10' STEEL STRAP



### STEEL STRAP

PS-10	10' (3 m) Steel strap
PS-25	25' (7.6 m) Steel strap
PS-50	50' (15 m) Steel strap
PS-100	100' (30.5m) Steel strap

TOOLS & ACCESSORIES

# CAP TUBE

## CAPILLARY TUBING

Short coils are boxed with application charts. Cut from 100' (30.5 m) sealed and dehydrated tube. S/B 100' (30.5 m) coils are boxed with conversion and application charts.

Available in cartons of 10.  
Add suffix -101 to part number.

**TC-26-16**  
SHORT COIL  
CAPILLARY TUBING



### CAPILLARY TUBING

SHORT COIL	100' COILS	DESCRIPTION
TC-26-16	TC-26-100	0.026 ID x 0.072 OD x 16'
TC-31-12	TC-31-100	0.031 ID x 0.083 OD x 12'
TC-36-12	TC-36-100	0.036 ID x 0.087 OD x 12'
TC-42-12	TC-42-100	0.042 ID x 0.093 OD x 12'
TC-44-12	TC-44-100	0.044 ID x 0.109 OD x 12'
TC-49-11	TC-49-100	0.049 ID x 0.099 OD x 11'
TC-50-11	TC-50-100	0.050 ID x 0.114 OD x 11'
TC-54-11	TC-54-100	0.054 ID x 0.106 OD x 11'
TC-55-11	TC-55-100	0.055 ID x 0.125 OD x 11'
TC-59-10	TC-59-100	0.059 ID x 0.112 OD x 10'
TC-64-10	TC-64-100	0.064 ID x 0.125 OD x 10'
TC-70-12	TC-70-100	0.070 ID x 0.125 OD x 12'
TC-75-9	TC-75-100	0.075 ID x 0.125 OD x 9'
TC-80-10	TC-80-100	0.080 ID x 0.145 OD x 10'
TC-85-9	TC-85-100	0.085 ID x 0.145 OD x 9'
TC-90-7	TC-90-100	0.090 ID x 0.145 OD x 7'
TC-100-10	TC-100-100	0.100 ID x 0.156 OD x 10'

Pressure/Temperature charts can be found on our website at [www.jbind.com](http://www.jbind.com) under "Instruction Sheets." Please see the "Copper Capillary Tubing" section for the conversion charts.

## ACID BRUSHES

Our acid brushes are ideal for thread sealant, flux, and past solders. Made of 100% long and stiff horsehair bristles that are evenly placed and securely crimped into tinned acid-resisting handles.



**C33804**  
1/4" FLUX BRUSH  
(12 PACK)

### ACID BRUSHES

PART NO.	DESCRIPTION
C33804	1/4" Flux brush (12 pack)
C33808	1/2" Flux brush (10 pack)
C33808-CTN	1/2" Flux brush (144 bulk)

## GAUGE FILE AND CUTTING TOOL

*A10971 CAP TUBE AND FILE IN POUCH*  
*A10972 CAP TUBE FILE*

Precision engineered with stainless steel wire plugs. Features a specially designed file to cut and open tubes. The numbers are etched in black for better legibility. Fourteen ID sizes from 0.026 units to 0.090 units and 22 OD sizes from 0.072" to 7/16" (5 to 12 mm). Use both the ID and OD calibrations to correctly determine tube size. Place tube in "V" slot to measure OD. Pin gauge measures ID.

The cap tube file is designed to cut and open the tube by filing a notch around the tubing at desired cutting point. Snap tube by bending at the notch and clean burrs by reaming out with the special file tip.

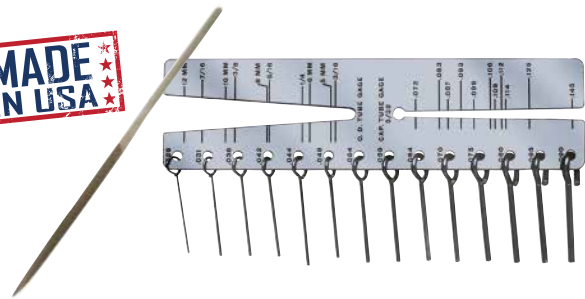

## CAP TUBE CUTTING TOOL

*A10973*

The sturdy design of our cap tube cutter results in no collapsing of the tube, no chips, and clean cuts.



# CAP TUBE

## CAP TUBE LENGTH CONVERSION CHART

Part No.	TC-26	TC-31	TC-36	TC-42	TC-44	TC-49	TC-50	TC-54	TC-55	TC-59	TC-64	TC-70	TC-75	TC-80	TC-85	TC-90
Tube ID	0.026 ID	0.031 ID	0.036 ID	0.042 ID	0.044 ID	0.049 ID	0.050 ID	0.054 ID	0.055 ID	0.059 ID	0.064 ID	0.070 ID	0.075 ID	0.080 ID	0.085 ID	0.090 ID
0.024	1.44															
0.025	1.20															
0.026	1.00	2.24														
0.028	0.72	1.59														
0.030	0.52	1.16														
0.031	0.45	1.00	2.00													
0.032		0.86	1.75													
0.033		0.50	1.54													
0.034		0.65	1.35													
0.035		0.58	1.16	2.31												
0.036		0.50	1.00	2.10												
0.037		0.45	0.90	1.79	2.22											
0.038		0.39	0.80	1.59	1.92											
0.039		0.31	0.71	1.41	1.75											
0.040		0.28	0.62	1.25	1.55	2.51										
0.041		0.25	0.56	1.12	1.38	2.26	2.50									
0.042		0.23	0.50	1.00	1.24	2.03	2.23									
0.043		0.20	0.45	0.87	1.11	1.83	1.98									
0.044			0.39	0.81	1.00	1.62	1.79									
0.045			0.35	0.73	0.90	1.47	1.60	2.32								
0.046			0.32	0.67	0.82	1.34	1.47	2.08	2.27							
0.047				0.59	0.74	1.20	1.31	1.89	2.06							
0.048				0.54	0.67	1.10	1.20	1.72	1.87							
0.049				0.49	0.61	1.00	1.09	1.55	1.69							
0.050				0.45	0.56	0.91	1.00	1.43	1.56	2.14						
0.051				0.41	0.51	0.84	0.90	1.31	1.44	1.96						
0.052					0.47	0.76	0.85	1.19	1.32	1.78						
0.053					0.43	0.69	0.78	1.09	1.20	1.64						
0.054					0.39	0.65	0.70	1.00	1.09	1.52	2.18					
0.055					0.36	0.59	0.64	0.92	1.00	1.38	2.00					
0.056						0.54	0.60	0.85	0.94	1.27	1.85					
0.057						0.50	0.55	0.79	0.87	1.17	1.72					
0.058						0.46	0.51	0.73	0.80	1.07	1.56					
0.059						0.42	0.47	0.67	0.73	1.00	1.44	2.18				
0.060						0.39	0.43	0.62	0.67	0.93	1.33	2.04				
0.064							0.32	0.47	0.50	0.69	1.00	1.50	2.07			
0.070								0.30	0.33	0.46	0.67	1.00	1.37	1.84		
0.075											0.48	0.73	1.00	1.37	1.75	
0.080												0.54	0.74	1.00	1.32	1.71
0.085													0.57	0.76	1.00	1.29
0.090													0.43	0.62	0.76	1.00
0.095														0.46	0.60	0.79
0.100															0.48	0.62
0.105																0.49

**TO USE CHART**

1. Locate recommended cap tube ID in left column.
2. Read across and find conversion factor under copper cap tube size.
3. Multiply the given length of the cap tube by the conversion factor.
4. The resultant length of the cap tube will give you the same flow characteristics as the original recommended cap tube.

**EXAMPLE:** LOCATE 0.040 IN LEFT HAND COLUMN AND READING ACROSS GIVES THE FOLLOWING CONVERSION FACTOR: NO. TC-36 CAP TUBE (0.036 ID) -0.62 AND NO. TC-42 CAP TUBE (0.042 ID) -1.25. MULTIPLY THE RECOMMENDED CAP TUBE LENGTH OF 9' BY THE CONVERSION FACTOR GIVES THE FOLLOWING RESULTS: 5.5' - 0.036 ID AND 11.25' - 0.042 ID. EITHER OF THESE TWO CAP TUBES WILL GIVE THE SAME RESULTS AS THE ORIGINAL CAP TUBE OF 9' -0.040 ID.

Every precaution should be taken to prevent chips, dirt, flux, moisture, etc., from entering the system when changing the cap tube. Most cap tube has very small holes that do not require much debris to plug flow.

The size of the cap tube is critical to its application. While some variation from the ideal can be tolerated, it is important to understand those factors which the service engineer can control. Unlike orifices such as expansion valve seats, capillary tubing depends on its length as well as its diameter to determine the total restriction. A change in diameter on a percentage basis can change the flow more than an equal change in length. For example, changing the diameter by 0.005" as between 0.026" ID and 0.031" ID can double the flow.

The length of the cap tube is the one factor over which the service engineer has the easiest and most immediate control. The best known method of changing the restriction of a cap tube is to change its length. Cut off a piece and its restriction is reduced. Substitute a longer tube and increase the restriction. However, there are factors that are not generally understood that limit the amount of lengthening or shortening.

As a general rule, keep the cap tube no shorter than 5 feet and no longer than 16 feet to eliminate many problems. Only plug drawn capillary tubing should be used in refrigeration and air conditioning applications. JB capillary tubing is drawn to a plus or minus 0.001" on the ID, the finest attainable. Therefore, we recommend using JB cap tubing and the application charts included in the packaging.

The "Capillary Tubing Length Conversion Chart" was developed to enable users of capillary tubing to use standard tubing sizes which are widely available. While many OEMs recommend specific lengths and diameters of cap tube for their units, these tube sizes are not always readily available and may have to be special ordered.

This conversion chart enables the user to translate the recommended length into that of a tube diameter that can be quickly obtained. In using the chart, it is recommended that conversions be made using factors within the shaded area. In addition, it is highly recommended that the minimum length of capillary tubing used is 5 feet.

TOOLS & ACCESSORIES

## R-134A AUTOMOTIVE COUPLERS

Quick connect/disconnect valve actuation without refrigerant venting. Safety sleeve holds coupler securely to service port. Color-coded knobs.

### 134A AUTOMOTIVE COUPLERS

PART NO.	DESCRIPTION
AC-13430	High side 90 degree snap coupler x 14 mm
AC-13435	Low side 90 degree snap coupler x 14 mm
AC-15530	High side 90 degree snap coupler x 1/4" SAE
AC-15535	Low side 90 degree snap coupler x 1/4" SAE

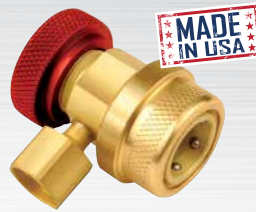

**AC-13430**  
14mm HIGH SIDE 90°  
SNAP COUPLER



**AC-15530**  
1/4" HIGH SIDE 90°  
SNAP COUPLER

## R-134A AUTOMOTIVE QUICK ADAPTER

Retrofit existing SAE flare fitting for R-134a auto service.

### R-134A AUTOMOTIVE QUICK ADAPTER

PART NO.	QC GASKET	DESCRIPTION
QC-S4A-134A	P509	1/4" QC x 1/2" male ACME thread
QC-13445-134A	P510	1/2" ACME QC x 1/4" male flare



**QC-13445-134A**  
1/2" ACME QC X 1/4" MALE FLARE



**QC-S4A-134A**  
1/4" QC X 1/2" MALE ACME THREAD

## 1/2" ACME THREAD HALF UNION

### 1/2" ACME THREAD HALF UNION

PART NO.	DESCRIPTION
AF-13450	1/8" NPTF
AF-13451	1/4" NPTF
AF-13452	3/8" NPTF
AF-13455	1/4" Female SAE
AF-13457	3/8" Female SAE

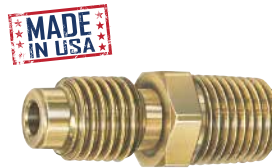

**AF-13451**  
1/4" NPTF ACME  
THREAD HALF UNION

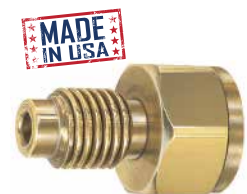

**AF-13455**  
1/4" FEMALE SAE ACME  
THREAD HALF UNION

## AUTOMOTIVE OIL TAP TUBE

End the mess in oil changes and save time on service calls with JB's oil tap access tube. This access tube reduces motor burnout by simplifying acid tests and can be left in place for future tests and changes.

### OIL TAP TUBE

A33600	Oil tap tube
--------	--------------



**A33600**  
OIL TAP TUBE

## 1/2" ACME SERVICE VALVE

### 1/2" ACME SERVICE VALVE

AF-13550	1	1/2" ACME x 1/8" NPTF w/13494 cap
----------	---	-----------------------------------



**AF-13550**

# LA-CO PRODUCTS

## COOL GEL™ HEAT DISSIPATING SPRAY 11509

Heat dissipating spray helps prevent heat damage to components and surrounding materials during soldering, brazing, and welding. It protects painted and finished surfaces from discoloration due to adjacent torch operations. This product also reduces the danger of fire to surrounding surfaces such as studs, drywall, and insulation. The unique non-staining gelled formula sticks to surfaces without dripping or running off and leaves no residue. Safe, non-toxic, and odorless. The spray pattern is adjustable from stream to mist. One quart spray bottles sold in cases of 12.



## PIPETITE-STIK® 11175

Non-toxic and lead-free, the Pipetite Stik® is for use for water, steam, air, natural gas, and LP gas. Use on metal threads. Do not use on Oxygen service; use PTFE tape or LA-CO Oxytite®. Sealing temperature is up to 350° F (177° C) and pressures to 2,000 psi (136 bar) for liquids and 350 psi (24 bar) for gasses. Certified by NSF to meet ANSI/NSF Standard 61 for use on potable water. 1-1/4 oz. sticks sold in cases of 12.



## VALVE ACTION™ PAINT MARKER 96822 RED 96823 BLACK

This long-lasting, weather-, water-, and UV-resistant paint marker dries in 3 minutes. Marks on all surfaces including metal, wood, glass, plastic, rubber, cardboard, and paper. Lead-free paint meets California VOC regulations. Marking range is -50° F to 150° F (-46°C to 66°C). Sold in bulk cases of 12.



## HEAT-SEAL STIK® PREMIXED EPOXY SEALER 11575

Ideal for use on high and low side of refrigeration systems, the Heat-Seal Stik® can be used on aluminum, copper, other metals, glass, and ceramics. Works on R-410A based systems. Sticks, melts, seals, and cures in one 90 second operation. One part epoxy, there is no mixing or measuring needed. Sealing temperature is up to 350° F (177° C) and pressures to 450 psi (31 bar). 3/8 oz. sticks sold in cases of 12.



## SLIC-TITE® PASTE WITH PTFE 42019

Premium thread sealant for sealing water, air, steam, natural gas, LP gas, refrigerants, ammonia, gasoline, and oil. For use on metal, PVC, CPVC, and ABS plastic threads. Do not use on Oxygen service; use PTFE tape or LA-CO Oxytite®. Sealing temperature -50° F to 500° F (-46° C to 260° C). Pressures 3,000 psi (204 bar) for gas, 10,000 psi (680 bar) for liquid. NSF, UPC, CSA, cULus, FGG/BM/CZ approved. 1/2 pints sold in cases of 12.



## BLOC-IT® HEAT ABSORBING PASTE 11511

Heavy paste effectively absorbs surface heat and protects adjoining surfaces that may be damaged by excessive heat. Typically used to protect rubber, plastic, distortion, painted and finished surfaces during soldering, brazing or welding. Safe to use, Bloc-It® is non-toxic, harmless to skin, odorless, and does not contain asbestos. Wipe off with cloth or wash with water, Bloc-It® will not leave stains. 10 oz. tubes sold in cases of 24.



TOOLS &  
ACCESSORIES



# BRASS FITTINGS

## ALL 100% MADE IN THE USA



### JB'S AMERICAN MADE BRASS SAE 45° FLARED TUBE FITTINGS

JB's American made brass SAE 45° flared tube fittings may be used with copper, brass, aluminum, steel, and plastic tube provided an acceptable flare could be generated with the material.

Vacuum and pressures of 5,000 psi can be handled depending upon the size, material, and conditions. Using a 4:1 safety factor, the following general rule (excluding plastic tube) is used:

- 3,000 PSI TO 1/4"
- 2,000 PSI TO 1/2"
- 1,500 PSI TO 1"

Long nuts are recommended when vibration is a factor. Tubing should be double-flared in extreme applications to minimize flare thinning on over-tightening.

Fittings listed generally comply with SAE, ASA, ASME, and MS standards; however, when design makes dimensions critical, please contact us at 800.323.0811 for samples and/or prints for testing and evaluation.

Tube sizes listed are OD (outside diameter). To determine nominal (water tube) size, subtract 1/8", thus 5/8" OD equals 1/2" nominal.

Pipe sizes listed are standard nominal pipe size and threads are to Dryseal Taper Pipe Standards.

JB will provide flare fitting to SAE Standard J513 whenever possible. In some cases, slight deviations will occur when full compliance fittings are not available.

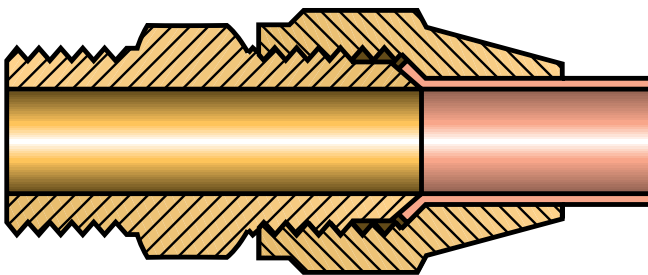

### FEATURES

- MAKE AND BREAK
- GOOD VIBRATION RESISTANCE (IMPROVED BY USING LONG NUTS)
- LOW COST
- EASY ASSEMBLY
- WIDE SELECTION

Heavy-duty ACR tube fittings generally conform to SAE, ASA, and ARI Standards for hydraulic, marine, and refrigeration service. Long dryseal pipe threads minimize leakage and provide more clearance for tightening flare nuts. Shapes, elbows, tees, etc., are made from brass forgings to maximize strength and eliminate cracks.

### ASSEMBLY INSTRUCTIONS

- CUT TUBE SQUARE AND REMOVE CUT-OFF BURR
- SLIDE NUT ON TUBE, THREADED END FACING END OF TUBE
- FLARE TUBE FOLLOWING FLARING TOOL MANUFACTURERS INSTRUCTIONS (CHECK FLARE QUALITY)
- THREAD NUT ON TO FITTING BODY "HAND TIGHT"
- WITH PROPER WRENCH, TIGHTEN TO A SOLID FEEL

CAUTION: Over-tightening and dirt can damage fittings and/or tube causing leaks.

NOTE: Lubrication of flare faces and threads is recommended when practical.

#### THREAD SIZE OF TUBE ENDS

OD TUBE	SAE - FLARE	OD TUBE	SAE FLARE
1/8"	5/16" - 24	1/2"	3/4" - 16
3/16"	3/8" - 24	5/8"	7/8" - 14
1/4"	7/16" - 20	3/4"	1 1/16" - 14
5/16"	1/2" - 20	7/8"	1 1/4" - 12
3/8"	5/8" - 18	1"	1 3/8" - 12
7/16"	11/16" - 16	-----	-----

#### TORQUE POUNDS FOR FLARE FITTING DRY THREAD

SIZE	FT. LBS.
1/4"	8-10
3/8"	15-25
1/2"	25-35
5/8"	40-55
3/4"	50-60

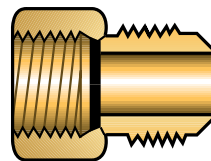

Copper seal gaskets (B2) series furnished with all female flares.

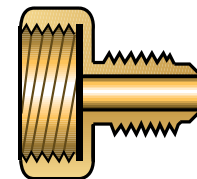

Fiber gaskets (K1 and D/E) furnished with all drum adapters (K1-1 through 8).





# BRASS FITTINGS

## ALL 100% MADE IN THE USA



### COPPER FLARE BONNET

Use with flare nut to cap a fittings.



COPPER FLARE BONNET		
PART NO.	SIZE	QTY.
B1-3	3/16"	5
B1-4	1/4"	25
B1-6	3/8"	5
B1-8	1/2"	5
B1-10	5/8"	10
B1-12	3/4"	10

### COPPER FLARE GASKET

Used on brass-to-brass or brass-to-steel connections to prevent leaks.



COPPER FLARE GASKET		
PART NO.	SIZE	QTY.
B2-3	3/16"	5
B2-4	1/4"	25
B2-5	5/16"	5
B2-6	3/8"	25
B2-8	1/2"	25
B2-10	5/8"	10
B2-12	3/4"	10

### FLARE X FEMALE SOLDER ELL



FLARE X FEMALE SOLDER ELL		
PART NO.	SIZE	QTY.
ES2-44	1/4" x 1/4"	5
ES2-66	3/8" x 3/8"	5
ES2-68	3/8" x 1/2"	2
ES2-88	1/2" x 1/2"	2

### CROSS



CROSS		
PART NO.	SIZE	QTY.
C1-4	1/4"	2
C1-6	3/8"	2

### FLARE X MALE PIPE ELL



FLARE X MALE PIPE ELL		
PART NO.	SIZE	QTY.
E1-2A	1/8" x 1/8"	5
E1-3A	3/16" x 1/8"	2
E1-4A	1/4" x 1/8"	10
E1-4B	1/4" x 1/4"	10
E1-4C	1/4" x 3/8"	5
E1-5A	5/16" x 1/8"	5
E1-5B	5/16" x 1/4"	5
E1-5C	5/16" x 3/8"	5
E1-6A	3/8" x 1/8"	5
E1-6B	3/8" x 1/4"	10
E1-6C	3/8" x 3/8"	10
E1-6D	3/8" x 1/2"	5
E1-6E	3/8" x 3/4"	2
E1-8B	1/2" x 1/4"	5
E1-8C	1/2" x 3/8"	5
E1-8D	1/2" x 1/2"	10
E1-8E	1/2" x 3/4"	2
E1-10C	5/8" x 3/8"	2
E1-10D	5/8" x 1/2"	2
E1-10E	5/8" x 3/4"	2
E1-12D	3/4" x 1/2"	2
E1-12E	3/4" x 3/4"	2

### FLARE ELL & REDUCING FLARE ELL



FLARE ELL		
PART NO.	SIZE	QTY.
E2-2	1/8"	5
E2-3	3/16"	5
E2-4	1/4"	5
E2-5	5/16"	5
E2-6	3/8"	5
E2-8	1/2"	5
E2-10	5/8"	2
E2-12	3/4"	2

REDUCING FLARE ELL		
PART NO.	SIZE	QTY.
ER2-64	3/8" x 1/4"	5
ER2-84	1/2" x 1/4"	2
ER2-86	1/2" x 3/8"	5
ER2-108	5/8" x 1/2"	2

### FLARE X FEMALE PIPE ELL



FLARE X FEMALE PIPE ELL		
PART NO.	SIZE	QTY.
E3-4A	1/4" x 1/8"	5
E3-4B	1/4" x 1/4"	2
E3-5B	5/16" x 1/4"	2
E3-6A	3/8" x 1/8"	5
E3-6B	3/8" x 1/4"	2
E3-6C	3/8" x 3/8"	2
E3-6D	3/8" x 1/2"	2
E3-8C	1/2" x 3/8"	2
E3-8D	1/2" x 1/2"	2
E3-8E	1/2" x 3/4"	2
E3-10D	5/8" x 1/2"	2
E3-10E	5/8" x 3/4"	2

### SWIVEL FEMALE FLARE X FLARE ELL



SWIVEL FEMALE FLARE X FLARE ELL		
PART NO.	SIZE	QTY.
ES4-44	1/4" x 1/4"	2
ES4-66	3/8" x 3/8"	2
ES4-88	1/2" x 1/2"	2
ES4-1010	5/8" x 5/8"	2
ES4-1212	3/4" x 3/4"	2

### FEMALE FLARE X FLARE ELL

Includes copper gasket.



FEMALE FLARE X FLARE ELL		
PART NO.	SIZE	QTY.
E4-44	1/4" x 1/4"	5
E4-66	3/8" x 3/8"	2
E4-88	1/2" x 1/2"	2

### FUSIBLE PIPE PLUG

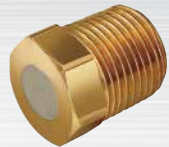

FUSIBLE PIPE PLUG		
PART NO.	SIZE	QTY.
<b>168°F</b>		
FP-A-168	1/8"	5
FP-B-168	1/4"	5
FP-C-168	3/8"	2
<b>210°F</b>		
FP-A-210	1/8"	5
FP-B-210	1/4"	5
FP-C-210	3/8"	2
<b>283°F</b>		
FP-A-283	1/8"	5
FP-B-283	1/4"	2
FP-C-283	3/8"	2

### REFRIGERANT DRUM ADAPTER

NPS cylinder x male flare. Furnished with fiber gasket.



REFRIGERANT DRUM ADAPTER		
PART NO.	SIZE	QTY.
K1-1	3/4" x 1/4"	10
K1-3	3/4" x 3/8"	2
K1-5	3/4" x 1/2"	2
K1-8	1/2" x 1/4"	2

BRASS FITTINGS

# BRASS FITTINGS

100% MADE IN USA



## FIBER DRUM ADAPTER SEAL GASKET



FIBER DRUM ADAPTER SEAL GASKET		
PART NO.	SIZE	QTY.
K1-D	1/2"	10
K1-E	3/4"	10

## FLARE CAP



FLARE CAP		
PART NO.	SIZE	QTY.
N5-3	3/16"	5
N5-4	1/4"	25
N5-5	5/16"	5
N5-6	3/8"	25
N5-8	1/2"	10
N5-10	5/8"	10
N5-12	3/4"	2

## OLD STYLE EXTRA HEAVY PRE-1968 NUT



OLD STYLE EXTRA HEAVY PRE-1968 NUT		
PART NO.	SIZE	QTY.
HNS4-4	1/4"(3/4" hex)	25
HNS4-6	3/8"(7/8" hex)	25
HNS4-8	1/2"(1" hex)	10
HNS4-10	5/8"(1 1/8" hex)	10
HNS4-12	3/4"(1 3/8" hex)	2

## FLARE X FLARE X MALE PIPE TEE



FLARE X FLARE X MALE PIPE TEE		
PART NO.	SIZE	QTY.
T1-4A	1/4" x 1/4" x 1/8"	10
T1-4B	1/4" x 1/4" x 1/4"	10
T1-4C	1/4" x 1/4" x 3/8"	2
T1-5B	5/16" x 5/16" x 1/4"	2
T1-6B	3/8" x 3/8" x 1/4"	5
T1-6C	3/8" x 3/8" x 3/8"	5
T1-6D	3/8" x 3/8" x 1/2"	2
T1-8B	1/2" x 1/2" x 1/4"	2
T1-8C	1/2" x 1/2" x 3/8"	2
T1-8D	1/2" x 1/2" x 1/2"	2
T1-10C	5/8" x 5/8" x 3/8"	2
T1-10D	5/8" x 5/8" x 1/2"	2

## FUSIBLE FLARE X PIPE ADAPTER



FUSIBLE FLARE X PIPE ADAPTER		
168° F		
FU-4B-168	1/4" x 1/4"	2
FU-4C-168	1/4" x 3/8"	2
FU-6C-168	3/8" x 3/8"	2
210° F		
FU-4B-210	1/4" x 1/4"	2
FU-4C-210	1/4" x 3/8"	2
FU-6C-210	3/8" x 3/8"	2
283° F		
FU-4B-283	1/4" x 1/4"	2
FU-4C-283	1/4" x 3/8"	2
FU-6C-283	3/8" x 3/8"	2

## SHORT FORGED REFRIGERATION NUT & REDUCING



SHORT FORGED REFRIGERATION NUT		
NS4-3	3/16"	10
NS4-4	1/4"	25
NS4-4-CS	1/4"	1000
NS4-5	5/16"	10
NS4-6	3/8"	25
NS4-6-CS	3/8"	500
NS4-8	1/2"	25
NS4-8-CS	1/2"	350
NS4-10	5/8"	10
NS4-10-CS	5/8"	200
NS4-12	3/4"	5
NS4-12-CS	3/4"	100
NS4-14	7/8"	2

## FROST-PROOF FORGED REFRIGERATION NUT

Holes relieve frost in thread area.



FROST-PROOF FORGED REFRIGERATION NUT		
NST4-4	1/4"	5
NST4-6	3/8"	5
NST4-8	1/2"	10
NST4-10	5/8"	2

## FLARE TEE & REDUCING



FLARE TEE		
T2-3	3/16"	5
T2-4	1/4"	10
T2-5	5/16"	5
T2-6	3/8"	10
T2-8	1/2"	5
T2-10	5/8"	2
T2-12	3/4"	2
REDUCING FLARE TEE		
TR2-446	1/4" x 1/4" x 3/8"	5
TR2-664	3/8" x 3/8" x 1/4"	5
TR2-668	3/8" x 3/8" x 1/2"	2
TR2-886	1/2" x 1/2" x 3/8"	2

## LONG FORGED REFRIGERATION NUT

Increase vibration resistance.



LONG FORGED REFRIGERATION NUT		
N4-4	1/4"	10
N4-5	5/16"	5
N4-6	3/8"	10
N4-8	1/2"	5
N4-10	5/8"	5
N4-12	3/4"	2

REDUCING SHORT FORGED REFRIGERATION NUT		
NRS4-43	1/4" x 3/16"	5
NRS4-54	5/16" x 1/4"	5
NRS4-64	3/8" x 1/4"	10
NRS4-65	3/8" x 5/16"	10
NRS4-86	1/2" x 3/8"	10
NRS4-108	5/8" x 1/2"	5
NRS4-1210	3/4" x 5/8"	2

## FLARE PLUG



FLARE PLUG		
P2-3	3/16"	5
P2-4	1/4"	10
P2-5	5/16"	5
P2-6	3/8"	10
P2-8	1/2"	10
P2-10	5/8"	5
P2-12	3/4"	2

## FINGER-TIGHT FLARE CAP

Neoprene seal. See page 58 for single information.



FINGER-TIGHT FLARE CAP		
NFT5-4-101	1/4"	1000
NFT5-6-101	3/8"	500

# BRASS FITTINGS

100% MADE IN USA



## FLARE X MALE PIPE X FLARE TEE



PART NO.	SIZE	QTY.
T3-4A	1/4" x 1/8" x 1/4"	5
T3-4B	1/4" x 1/4" x 1/4"	5
T3-5B	5/16" x 1/4" x 5/16"	2
T3-6B	3/8" x 1/4" x 3/8"	5
T3-6C	3/8" x 3/8" x 3/8"	2
T3-6D	3/8" x 1/2" x 3/8"	2
T3-8C	1/2" x 3/8" x 1/2"	2
T3-8D	1/2" x 1/2" x 1/2"	2
T3-10D	5/8" x 1/2" x 5/8"	2

## FLARE UNION & REDUCING



PART NO.	SIZE	QTY.
U2-2	1/8"	5
U2-3	3/16"	5
U2-4	1/4"	25
U2-5	5/16"	10
U2-6	3/8"	25
U2-8	1/2"	10
U2-10	5/8"	10
U2-12	3/4"	2
U2-14	7/8"	2

REDUCING FLARE UNION		
PART NO.	SIZE	QTY.
UR2-43	1/4" x 3/16"	5
UR2-54	5/16" x 1/4"	5
UR2-64	3/8" x 1/4"	10
UR2-65	3/8" x 5/16"	5
UR2-84	1/2" x 1/4"	5
UR2-86	1/2" x 3/8"	10
UR2-106	5/8" x 3/8"	5
UR2-108	5/8" x 1/2"	5
UR2-128	3/4" x 1/2"	2
UR2-1210	3/4" x 5/8"	2

## FLARE X FEMALE PIPE ADAPTER



PART NO.	SIZE	QTY.
U3-2A	1/8" x 1/8"	5
U3-3A	3/16" x 1/8"	5
U3-4A	1/4" x 1/8"	10
U3-4B	1/4" x 1/4"	10
U3-4C	1/4" x 3/8"	5
U3-5A	5/16" x 1/8"	5
U3-5B	5/16" x 1/4"	5
U3-6A	3/8" x 1/8"	5
U3-6B	3/8" x 1/4"	5
U3-6C	3/8" x 3/8"	5
U3-6D	3/8" x 1/2"	5
U3-8B	1/2" x 1/4"	5
U3-8C	1/2" x 3/8"	5
U3-8D	1/2" x 1/2"	5
U3-8E	1/2" x 3/4"	2
U3-10C	5/8" x 3/8"	5
U3-10D	5/8" x 1/2"	5
U3-10E	5/8" x 3/4"	2

## FLARE X SOLDER ADAPTER

Furnished with copper gasket.



PART NO.	SIZE	QTY.
US3-44	1/4" x 1/4"	10
US3-45	1/4" x 5/16"	5
US3-46	1/4" x 3/8"	5
US3-64	3/8" x 1/4"	5
US3-65	3/8" x 5/16"	5
US3-66	3/8" x 3/8"	10
US3-68	3/8" x 1/2"	5
US3-610	3/8" x 5/8"	5
US3-86	1/2" x 3/8"	2
US3-88	1/2" x 1/2"	5
US3-810	1/2" x 5/8"	2
US3-108	5/8" x 1/2"	2
US3-1010	5/8" x 5/8"	5
US3-1012	5/8" x 3/4"	2
US3-1014	5/8" x 7/8"	2
US3-1212	3/4" x 3/4"	5
US3-1214	3/4" x 7/8"	2

## FLARE X MALE PIPE ADAPTER



PART NO.	SIZE	QTY.
U1-2A	1/8" x 1/8"	5
U1-3A	3/16" x 1/8"	5
U1-3B	3/16" x 1/4"	5
U1-4A	1/4" x 1/8"	25
U1-4B	1/4" x 1/4"	25
U1-4C	1/4" x 3/8"	10
U1-4D	1/4" x 1/2"	10
U1-5A	5/16" x 1/8"	5
U1-5B	5/16" x 1/4"	5
U1-5C	5/16" x 3/8"	5
U1-6A	3/8" x 1/8"	10
U1-6B	3/8" x 1/4"	10
U1-6C	3/8" x 3/8"	10
U1-6D	3/8" x 1/2"	10
U1-6E	3/8" x 3/4"	5
U1-8A	1/2" x 1/8"	2
U1-8B	1/2" x 1/4"	5
U1-8C	1/2" x 3/8"	10
U1-8D	1/2" x 1/2"	10
U1-8E	1/2" x 3/4"	5
U1-10B	5/8" x 1/4"	5
U1-10C	5/8" x 3/8"	5
U1-10D	5/8" x 1/2"	10
U1-10E	5/8" x 3/4"	5
U1-12C	3/4" x 3/8"	2
U1-12D	3/4" x 1/2"	2
U1-12E	3/4" x 3/4"	2
U1-14E	7/8" x 3/4"	2

## FEMALE FLARE X FLARE ADAPTER



PART NO.	SIZE	QTY.
UR3-43	1/4" x 3/16"	2
UR3-46	1/4" x 3/8"	10
UR3-48	1/4" x 1/2"	5
UR3-64	3/8" x 1/4"	20
UR3-68	3/8" x 1/2"	10
UR3-84	1/2" x 1/4"	10
UR3-86	1/2" x 3/8"	10
UR3-810	1/2" x 5/8"	10
UR3-108	5/8" x 1/2"	5
UR3-1012	5/8" x 3/4"	2
UR3-1210	3/4" x 5/8"	2

## FLARE X FLARE X FEMALE FLARE TEE



PART NO.	SIZE	QTY.
T6-4	1/4"	2

BRASS FITTINGS

# BRASS FITTINGS



100% MADE IN USA



## FEMALE FLARE X FEMALE FLARE CONNECTOR

Includes two copper gaskets.



## SWIVEL FEMALE FLARE X SOLDER ADAPTER

A32700 series  
pg 48.



## BRASS PIPE FITTINGS

JB's American made forged brass pipe fittings are manufactured from CA 377 alloy and are threaded to Dryseal Taper Pipe Standards to generally comply with SAE, ASA, ASME, and MS Standards. Forgings can be used on vacuums to pressures of 5,000 psi depending on size, material, and conditions.

### FEATURES:

- GOOD VIBRATION RESISTANCE (IMPROVED BY USING LONG NUTS)
- LOW COST
- EASY ASSEMBLY
- AMERICAN MADE QUALITY
- WIDE SELECTION

JB recommends the use of a compatible thread sealant and tightening 2 1/2 full turns past hand tight. Vacuum and pressures of 5,000 psi can be handled depending upon the size, material, and conditions.

Caution: Over-tightening and dirt can damage fittings. See page 72 for formats.

JB brass fittings are sold in box quantities only. For more information, please contact [sales@jbind.com](mailto:sales@jbind.com) or 800.323.0811.

FEMALE FLARE X FEMALE FLARE CONNECTOR		
PART NO.	SIZE	QTY.
U4-4	1/4"	10
U4-6	3/8"	10
U4-8	1/2"	2
U4-10	5/8"	2
U4-12	3/4"	2

SWIVEL FEMALE FLARE X SOLDER ADAPTER		
PART NO.	SIZE	QTY.
US5-44	1/4" x 1/4"	5
US5-66	3/8" x 3/8"	5
US5-88	1/2" x 1/2"	5
US5-1010	5/8" x 5/8"	5
US5-1212	3/4" x 3/4"	2

## SWIVEL FEMALE FLARE CONNECTOR



## FEMALE FLARE X MALE PIPE ADAPTER

Includes copper seal gasket.



SWIVEL FEMALE FLARE CONNECTOR		
PART NO.	SIZE	QTY.
US4-4	1/4"	10
US4-5	5/16"	5
US4-6	3/8"	10
US4-8	1/2"	10
US4-10	5/8"	5

FEMALE FLARE X MALE PIPE ADAPTER		
PART NO.	SIZE	QTY.
U5-4A	1/4" x 1/8"	5
U5-4B	1/4" x 1/4"	10
U5-6B	3/8" x 1/4"	5
U5-8C	1/2" x 3/8"	2
U5-8D	1/2" x 1/2"	2

### NOMINAL PIPE SIZE THREADS

NOM. PIPE	THD. / IN.	NOM. PIPE	THD. / IN.
1/16"	27	2"	11.5
1/8"	27	2-1/2"	8
1/4"	18	3"	8
3/8"	18	3-1/2"	8
1/2"	14	4"	8
3/4"	14	5"	8
1"	11.5	6"	8
1-1/4"	11.5	8"	8
1-1/2"	11.5	---	---

## FEMALE FLARE X FEMALE PIPE ADAPTER

Includes copper seal gasket.



## EXTRA LONG FLARE X MALE PIPE ADAPTER



FEMALE FLARE X FEMALE PIPE ADAPTER		
PART NO.	SIZE	QTY.
U6-4A	1/4" x 1/8"	2
U6-4B	1/4" x 1/4"	2

EXTRA LONG FLARE X MALE PIPE ADAPTER		
PART NO.	SIZE	QTY.
UX1-4A	1/4" x 1/8"	2
UX1-4B	1/4" x 1/4"	5

## EXTRA LONG FLARE UNION



EXTRA LONG FLARE UNION		
PART NO.	SIZE	QTY.
UX2-4	1/4"	5



# BRASS FITTINGS



100% MADE IN USA



## HEX BRUSHING (R1)



## LONG NIPPLE



## STREET ELL



## HEX NIPPLE (U10)



HEX BRUSHING (R1)		
PART NO.	SIZE	QTY.
110-BA	1/4" x 1/8"	10
110-CA	3/8" x 1/8"	5
110-CB	3/8" x 1/4"	10
110-DA	1/2" x 1/8"	5
110-DB	1/2" x 1/4"	10
110-DC	1/2" x 3/8"	10
110-EA	3/4" x 1/8"	2
110-EB	3/4" x 1/4"	5
110-EC	3/4" x 3/8"	5
110-ED	3/4" x 1/2"	5
110-FD	1" x 1/2"	2
110-FE	1" x 3/4"	2

LONG NIPPLE		
PART NO.	SIZE	QTY.
113-A15	1/8" x 1-1/2"	5
113-A2	1/8" x 2"	5
113-A25	1/8" x 2-1/2"	5
113-A3	1/8" x 3"	5
113-A35	1/8" x 3-1/2"	5
113-B15	1/4" x 1-1/2"	5
113-B2	1/4" x 2"	5
113-B25	1/4" x 2-1/2"	5
113-B3	1/4" x 3"	5
113-B35	1/4" x 3-1/2"	5
113-C15	3/8" x 1-1/2"	5
113-C2	3/8" x 2"	5
113-C25	3/8" x 2-1/2"	5
113-C3	3/8" x 3"	5
113-D15	1/2" x 1-1/2"	5
113-D2	1/2" x 2"	5
113-D25	1/2" x 2-1/2"	5
113-D3	1/2" x 3"	2
113-D35	1/2" x 3-1/2"	2

STREET ELL		
PART NO.	SIZE	QTY.
116-A	1/8" Forged	5
116-B	1/4" Closed forged	5
116-C	3/8" Closed forged	5
116-D	1/2" Forged	2

HEX NIPPLE (U10)		
PART NO.	SIZE	QTY.
122-A	1/8"	5
122-B	1/4"	10
122-C	3/8"	5
122-D	1/2"	5
122-E	3/4"	5

## CLOSE NIPPLE



CLOSE NIPPLE		
PART NO.	SIZE	QTY.
112-A	1/8"	5
112-B	1/4"	10
112-C	3/8"	5
112-D	1/2"	5
112-E	3/4"	5

## TEE



TEE		
PART NO.	SIZE	QTY.
101-A	1/8"	5
101-B	1/4"	10
101-C	3/8"	5
101-D	1/2"	2
101-E	3/4"	2

## HEX HEAD PLUG (P3)



HEX HEAD PLUG (P3)		
PART NO.	SIZE	QTY.
121-A	1/8"	10
121-B	1/4"	10
121-C	3/8"	5
121-D	1/2"	5
121-E	3/4"	5
121-F	1"	2

## COMPRESSION BREAK-OFF SLEEVE (PILOT) NUT



COMPRESSION BREAK-OFF SLEEVE (PILOT) NUT		
PART NO.	SIZE	QTY.
81LB-4	1/4"	10

## SWIVEL FEMALE FLARE CONNECTOR



## SWIVEL FEMALE FLARE CONNECTOR



ELL		
PART NO.	SIZE	QTY.
100-A	1/8"	5
100-B	1/4"	5
100-C	3/8"	5
100-D	1/2"	2
100-E	3/4"	2

COUPLING (PC)		
PART NO.	SIZE	QTY.
103-A	1/8"	5
103-B	1/4"	10
103-C	3/8"	5
103-D	1/2"	5
103-E	3/4"	5



BRASS FITTINGS

## JB INDUSTRIES OTC WARRANTY PROGRAM

THE ENTIRE LIMITED WARRANTY AND OTC WARRANTY CAN BE FOUND AT [WWW.JBIND.COM](http://WWW.JBIND.COM). PRODUCTS SOLD BY JB INDUSTRIES, INC. ARE WARRANTED FOR A PERIOD OF 12 MONTHS FROM THE DATE OF SALE WITH THE FOLLOWING EXCEPTIONS:

### VACUUM PUMPS: 24 MONTHS

\*ALL WARRANTY STATEMENTS APPLY TO BOTH PLATINUM® AND ELIMINATOR® PUMPS.

Pumps that are in warranty are examined as soon as they arrive at the warehouse so that we may contact the wholesaler regarding our determination. The over-the-counter warranty applies only to the manufacturing defects and is VOID if the problem has been determined to be abuse.

NOT CHANGING OIL WILL VOID WARRANTY

### CHECK FOR SIGNS OF ABUSE:

- A. BELL BACK HOUSING AREA
- B. BASE IS BROKEN OR MISSING CORNERS
- C. SIDE OF TRAP
- D. DAMAGE TO PROTECTIVE FINS AND DRAIN VALVE
- E. SIGHT GLASS SHOWS BUILDUP
- F. FLAT HIT MARKS ON TOP AND BOTTOM OF CORNERS
- G. HANDLE BENT DOWN OR BROKEN
- H. INTAKE DAMAGED OR MISSING

### THE WARRANTY IS VOID IF:

- 1. OIL HAS NOT BEEN USED IN PUMP OR CHANGED
- 2. CORROSIVE SUBSTANCES HAVE BEEN INTRODUCED IN THE PUMP
- 3. THE PUMP HAS BEEN ALTERED OR ANY COMPONENTS REMOVED OR MISSING

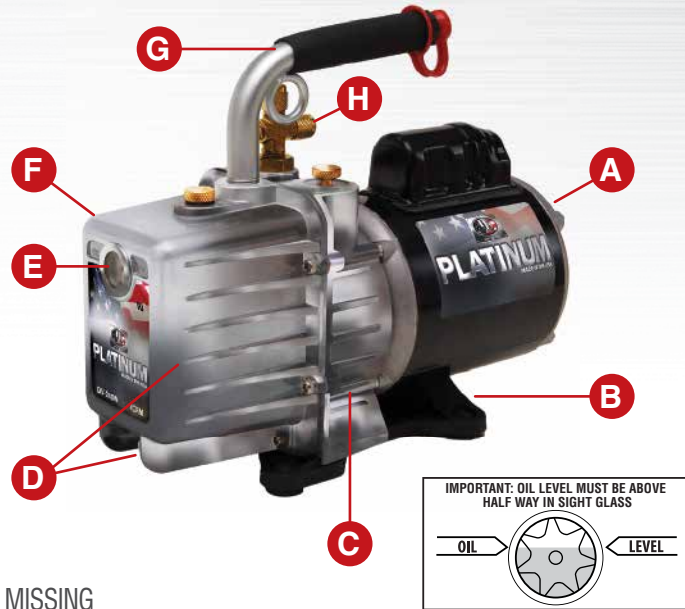

### MANIFOLDS: LIFETIME BAR ONLY

Manifolds carry a lifetime warranty on the bar only and does not include coverage of any parts. The 12 month over-the-counter warranty covers manufacturing defects only, not abuse. Signs of abuse include lens cracked or missing, gauges that can be loosened by hand, and drop marks on manifolds or unions. Check calibration with the set screw on the gauge as well.

### DIGITAL INSTRUMENTS (GAUGES, MANIFOLDS, LEAK DETECTORS): 12 MONTHS

ATLAS SCALE: 24 MONTHS; PROWLER: 24 MONTHS; LDC-4000: 24 MONTHS

Check the batteries. The product will provide a low battery warning with flashing dots at the bottom of the display. Plug in and toggle through the settings as well as the temperature setting to check if the sensors are working. If the sensors are working, push the on/off button to auto cal to see if it will return to zero. If any of the readings are off, check to see what the temperature sensor is for both sensors. A few degrees difference between the two can cause a problem with the readings. Check for signs of abuse which include a cracked case, drop marks on fittings, display is dimmed or damaged, sensor is pinched or sliced, and the hook is bent or missing.

### DIGITAL MICRON GAUGES: 12 MONTHS

For the DV-22N, check the last recorded vacuum and then press twice to clear the last recorded vacuum to see if it resets (if the numbers are jumping around, it may be a cold pump or oil contaminant inside the thermistor). If the numbers are jumping around after you have disconnected the gauge from the vacuum and it will not return to one, wait until the gauge auto calibrates. Unit will display JB and turn off before it reads 1 if batteries are low. JB vacuum gauges utilize a thermistor, which if contaminated, can result in faulty readings. Make sure that the sensors are cleaned with rubbing alcohol (Isopropyl) if readings seem erratic or as part of a regular maintenance regiment. DV-22N will display a "1" if vacuum reading is above 9,000 microns. The DV-40/DV-41 will display "0000000" when the vacuum level is above 12,000 microns. Check for signs of abuse which include a cracked case, the coupler is loose at the base of the case, the O-ring/gasket is chewed up or damaged or missing, there are pliers or channel locks on couplers, and the hook is broken or missing.

### F6-DP REFRIGERANT RECOVERY UNIT: 36 MONTHS

JB Industries warrants the F6-DP Refrigerant Recovery Machine to be free from defects of materials or workmanship for three years from the date of purchase. JB Industries does not warrant any machine that has been subjected to misuse, negligence, or accident, or has been repaired or altered by anyone other than JB Industries.

The compressor is warranted for a period of three years by the manufacturer. To keep this warranty in force, a filter (included) must be used on the inlet port or hose at all times to prevent particulates from entering the compressor. Failure to use the included filter will void the compressor warranty.

JB Industries liability is limited to repairing or replacing, at its option, a defective machine or part. If a defect arises, a valid claim must be received by JB Industries, with transportation prepaid, no later than thirty (30) days after the warranty period expires. JB Industries will determine whether the machine has malfunctioned due to defective materials or workmanship.

## ROTHENBERGER TOOLS: 24 MONTHS

Check for signs of abuse.

## HOW TO RETURN PRODUCT

Prior to returning any product to JB, you are required to obtain a Return Goods Authorization number (RGA). Contact customer service at 800-323-0811 to obtain your RGA. Insure that all returned products are packed adequately to avoid damage during shipment as we will not honor warranty claims for items damaged in transit. The recommended packing procedure for pumps is detailed below. Paperwork should be placed in a separate plastic bag and should include your assigned RGA, a description of the problem, a copy of the invoice, and any customer assigned repair or purchase order number (if applicable). Please provide contact information of whom to inform of package receipt as well as the person authorized to accept repair charges should the warranty be void.

***PLEASE MAKE SURE THAT ALL ITEMS ARE PACKAGED CORRECTLY TO PREVENT DAMAGE IN SHIPMENT. WE WILL NOT HONOR WARRANTY CLAIMS FOR ITEMS DAMAGED IN TRANSIT.***

***DO NOT PUT STICKERS OR STRONG TAPE ON FACES OF PRODUCTS AS ITEM MAY COME BACK WITH NO MANUFACTURER DEFECTS.***  
The recommended packing procedure for vacuum pumps is outlined below.

## RETURNING VACUUM PUMP FOR REPAIR

Before returning pump to factory, follow these steps to ensure that no additional charges are incurred because of poor packaging.

1. COMPLETELY DRAIN OIL FROM PUMP AND CLOSE OFF ALL VALVES. IF RED CAP IS ON PUMP PUT IN END OF HANDLE TO PREVENT LEAKAGE DURING TRANSIT.
2. PLACE PUMP IN PLASTIC BAG AND SEAL.
3. CUSHION BOTTOM OF CARTON WITH PACKING PAPER OR CRUMPLED NEWSPAPER BEFORE PUTTING PUMP IN CARTON. USE PACKING PAPER OR CRUMPLED NEWSPAPER AROUND ALL SIDES AND THE TOP. DO NOT USE PEANUTS.
4. PLACE ALL PAPERWORK IN A SEPARATE PLASTIC BAG AND SEAL. PLEASE INCLUDE RGA NUMBER ISSUED BY JB AND A DETAILED DESCRIPTION OF THE PROBLEM.
5. IF AN ESTIMATE IS REQUIRED PRIOR TO REPAIR, BE CERTAIN THIS IS CLEARLY SPECIFIED AND HIGHLIGHTED.
6. DEPENDING ON THE TIME OF YEAR, ALLOW 2-4 WEEKS FOR REPAIR SERVICE.

### SHIPPING INFO:

JB Industries  
Repair Department  
601 N. Farnsworth Ave.  
Aurora, IL 60505

### FOR VACUUM PUMP REPAIRS ONLY:

Customers in Alaska, Arizona, California, Idaho, Montana, Nevada, Oregon, Utah, and Washington have the option of sending their vacuum pump repairs to JB or to Merced Wholesale:

Merced AC Equipment Service  
805 S. Fremont  
Alhambra, CA 91803  
Phone: 626-293-5710 · Fax: 626-289-1961

## LIMITED WARRANTY:

JB limits this warranty to the repair, replacement or credit at invoice price (JB's option) of products that in JB's opinion are defective due to defects in workmanship and/or materials. Warranty claims resulting from obvious product abuse, misuse such as broken parts or lack of maintenance including failure to keep the vacuum pump filled with clean oil, abnormal use or normal wear and tear will not be honored as warranty repair and will be subject to JB's published repair costs. This express warranty is in lieu of and excludes all other warranties, guarantees and/or representations, express or implied, of JB and/or the manufacturer of such products that make NO WARRANTY OF MERCHANTABILITY OR FITNESS FOR ANY PARTICULAR PURPOSE. Technical information, recommendations and advice as to properties and usages of materials, design, installation and use of products, engineering and other matters are provided as an accommodation and are intended only as suggestions. Although they are believed to be accurate, based on JB's knowledge and experience, JB assumes no obligation or liability for any results obtained in their use or application, and they are not to be construed as establishing any warranty, express or implied. In no event shall JB be liable for claims for any damages whatsoever (whether direct, foreseeable, consequential or special) suffered by buyer or anyone else arising out of any breach by JB. JB makes no warranty to those defined as consumers in the Magnuson-Moss Warranty-Federal Trade Commission Improvement Act.

Disclaimers: All product items pictured, described, or otherwise displayed herein are subject to changes, alterations, and/or modifications at anytime by JB Industries, Inc. The terms and conditions for the purchase of JB Industries, Inc. products are subject to changes, alterations, and/or modifications at any time by JB Industries, Inc. and will be made available upon request to JB Industries Inc. and shall be provided to customers of JB Industries, Inc. at time of purchase.

## VACUUM PUMP REPAIR

### DV-42N THROUGH DV-285N PLATINUM® SERIES

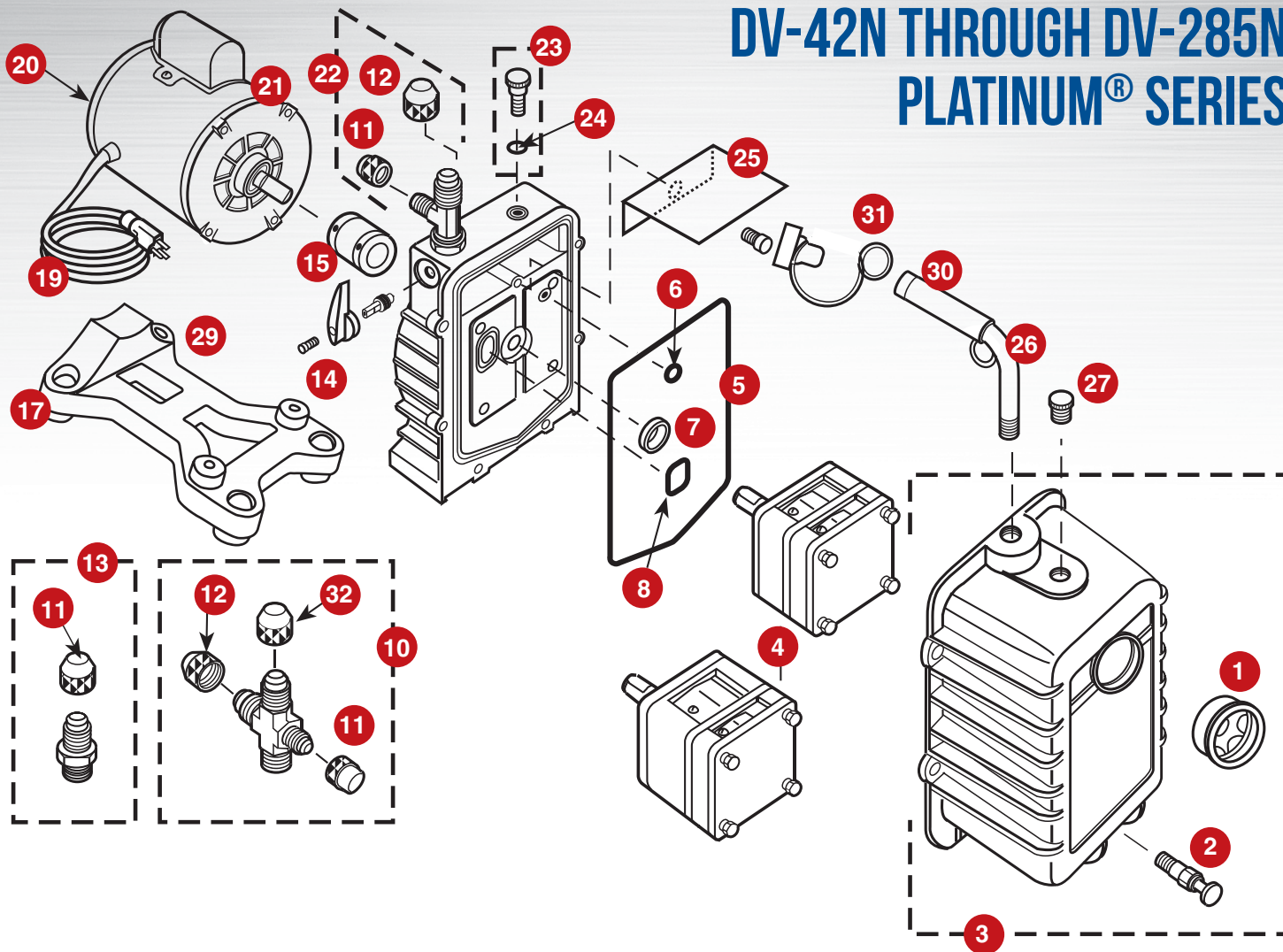

### NEW:

#### PR-308

NOTE: on flexible coupler (15)  
flexible section is available as

#### PR-209

now includes stem with  
O-rings and retainer

#### PR-56

adapter nut with O-ring

When ordering, please provide the  
following information:

- MODEL NUMBER
- FOUR DIGIT SERIAL NUMBER
- PART NUMBER AND DESCRIPTION

Operating instructions for all pumps  
manufactured since 1980 available  
under "technical information"  
at [www.jbind.com](http://www.jbind.com).



# REPAIR

PLATINUM® PUMP REPAIR PARTS		
REF. NO.	PART NO.	DESCRIPTION
1	PR-1	Sight glass
2	PR-2	Drain valve
3	PR-300	DV-42N through DV-200N cover assy. w/sight glass and drain valve
3	PR-301	DV-285N cover assy. w/sight glass and drain valve
3	PR-200	No longer available. Can substitute PR-201
3	PR-201	DV-142N & DV-200N cover assy. w/ sight glass, drain valve & guard
4	PR-302	DV-42N & DV-85N cartridge w/O-rings & cover seal
4	PR-303	DV-142N cartridge w/O-rings and cover seal
4	PR-304	DV-200N cartridge w/O-rings and cover seal
4	PR-314	DV-285N cartridge w/O-rings and cover seal
5	PR-217	Cover seal
5	PR-311	Cover seal
6	PR-211	Trap O-ring, gas ballast
7	PR-3	Shaft seal
8	PR-215	Trap O-ring, intake
8	PR-315	Trap O-ring, intake
9	PR-4	Rubber foot & screw assembly (1 per package)
10	PR-76	Intake caps with cross
11	NFT5-4	1/4" O-ring, intake
12	NFT5-6	3/8" O-ring cap
12	NFT5-8	1/2" O-ring cap
13	PR-32	1/4" Intake with cap
14	PR-209	Plastic isolation valve handle and screw w/ stem and retainer (not interchangeable w/PR-210)
14	PR-210	Metal isolation valve handle and screw

PLATINUM® PUMP REPAIR PARTS		
PART NO.	SIZE	DESCRIPTION
15	PR-208	Flexible Coupler
15	PR-308	Flexible Section Only
15	PR-6	Flexible Coupler
15	PR-77	Flexible Section Only
16	PR-42	Motor Foot With Screw
17	PR-59	Base Foot
19	PR-31	Line Cord (Emerson Motor)
19	PR-58	Line Cord (Marathon Motor)
20	PR-35	Rocker Switch With Prongs (Marathon 1101-0105)
20	PR-54	Rocker Switch With Wire Leads (Emerson)
21	PR-206	1/2 Hp, 115v, 60 Hz Motor With Line Cord And Switch
21	PR-207	1/2 Hp, 115/230v, 50/60 Hz Motor w/ Line Cord And Switch
22	PR-5	Intake Tee With Caps
23	PR-7	Gas Ballast Valve With O-ring
24	P90009	O-ring, Gas Ballast Valve
25	PR-40	Splash Guard And Screw (Excludes 3 CFM Manufactured Before 1/01. Use PR-39.)
26	PR-75	Cushioned Handle With Lift Ring 1/2" NPT And DV-EP-8 As Of 2008
26	PR-205	Cushioned Handle 3/8" NPT
27	PR-22	Oil Fill Plug with O-ring
28	PR-56	Adapter Nut With O-ring
29	PR-62	Pump Base (Includes Feet)
30	PR-500	Cushion And Cap 3/8" NPT
30	PR-501	Cushion And Cap 1/2" NPT
31	DV-EP6	Tethered Safety Cap 3/8"
31	DV-EP8	Tethered Safety Cap 1/2"
32	NFT5-8	1/2 Cap With O-ring

*Black Type: All pumps*

*Red Type: pumps manufactured beginning January 2001*

*Underlined Black Type: Pumps manufactured before January 2001*

*PR-62 will fit all pumps with serial #0101 and higher*

## NOT SHOWN

PR-18	Cartridge Valve Repair Kit (Includes DV-285N As Of 2007 Models)
PR-52	DV-285N Cartridge Valve Repair Kit Prior To 2007 Models
PR-45	Pump Repair Kit: PR-1, PR-2, PR-4(2), PR-42, PR-208

Operating instructions for all pumps manufactured since 1980 are available under "Technical Information" at [www.jbind.com](http://www.jbind.com).

## DV-3E, DV-4E AND DV-6E ELIMINATOR® SERIES

When ordering, please provide the following information:

- MODEL NUMBER
- FOUR DIGIT SERIAL NUMBER
- PART NUMBER AND DESCRIPTION

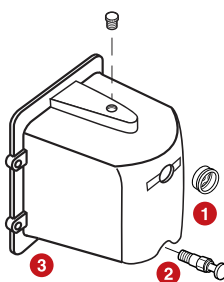
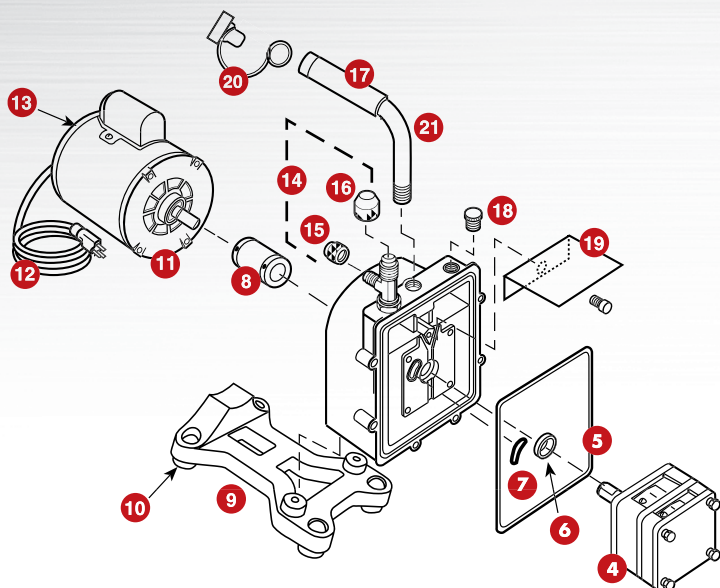

Current chrome cover will fit older black Eliminator® models.

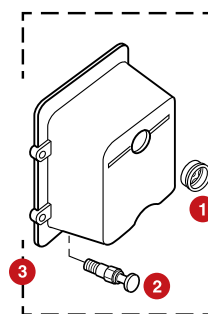

Black hammertone cover no longer available

### ELIMINATOR® PUMP REPAIR PARTS

REF. NO.	PART NO.	DESCRIPTION
1	PR-1	Sight Glass
2	PR-2	Drain Valve
3	PR-10	DV-3E, DV-4E And DV-6E Cover Assembly Includes Sight Glass, Drain Valve, Oil Fill Plug
4 New	PR-403	DV-3E Cartridge Complete With O-Rings & Cover Seal
4 New	PR-404	DV-4E Cartridge Complete With O-Rings & Cover Seal
4 New	PR-406	DV-6E Cartridge Complete With O-Rings & Cover Seal
5 New	PR-217	Cover Seal
6	PR-3	Shaft Seal
7	PR-315	Trap Intake O-Ring
8	PR-208	Flexible Coupler
8	PR-77	Flexible Section only
9	PR-62	Pump Base (Includes Rubber Feet)
10	PR-59	Rubber Foot
Not Shown	PR-18	Cartridge Valve Repair Kit

### ELIMINATOR® PUMP REPAIR PARTS

PART NO.	SIZE	DESCRIPTION
11	PR-207	1/2 Hp, 115/230 V, 50/60 Hz Motor With Line Cord And Switch
11	PR-206	1/2 Hp Motor With Line Cord And Switch
12	PR-31	Line Cord (Emerson Motor)
12 New	PR-58	Line Cord (Marathon Motor)
13	PR-54	Motor Switch, Rocker
14	PR-63	Intake Tee With Cap
15	NFT5-4	1/4" O-Ring Cap
16	NFT5-6	3/8" O-Ring Cap
17 Black	PR-500	3/8 Rubber grip & Cap
17 Hammertone	PR-501	1/2" Rubber grip & cap
18	PR-22	Oil Fill Plug With O-Ring
19	PR-39	DV-3E Splash Guard With Screw
19	PR-40	DV-4E And DV6E Splash Guard With Screw
20 Black	DV-EP6	Tethered Safety Plug 3/8"
20 Hammertone	DV-EP8	Tethered Safety Plug 1/2"
21 Black	PR-205	Cushioned Handle 3/8" NPT
21 Hammertone	PR-65	Cushioned Handle 1/2" NPT

## MANIFOLD REPAIR

### MANIFOLD REBUILD KITS

Rebuild kits are available for our manifold series. Standard rebuild kits include a stem, nut, piston with seat, and O-rings.

Premium rebuild kits feature 2 standard kits plus 2 hand wheels and screws.

*For safety reasons, gauges and hoses not specified for R-410A can damage product and cause injury. For manifold replacement parts, please refer to "manifold repair parts" below.*

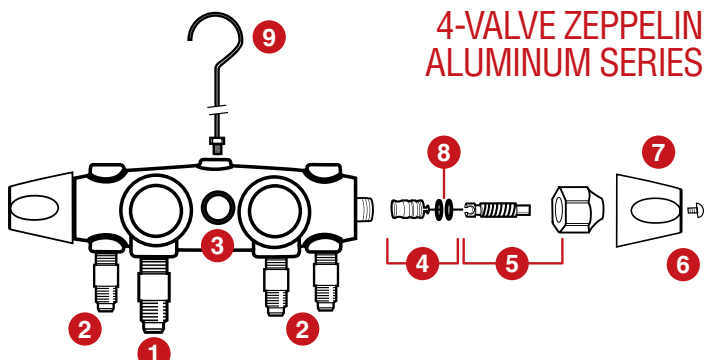
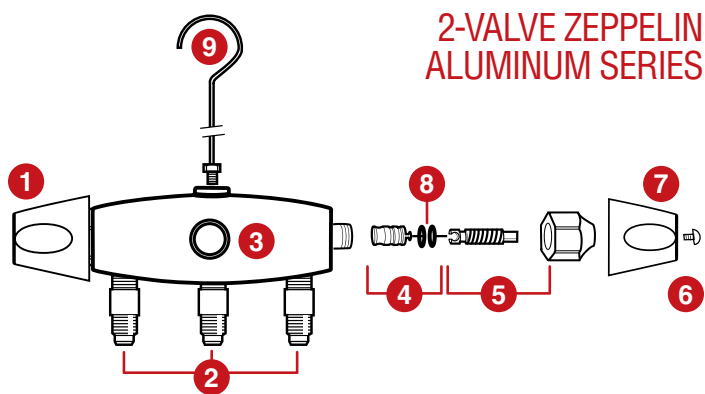
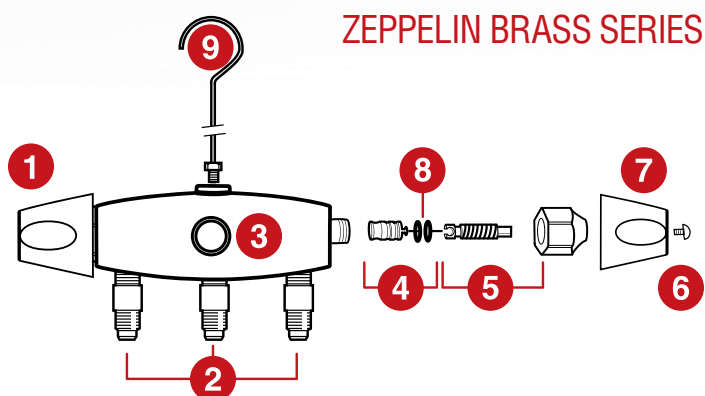

### MANIFOLD REBUILD KITS

PART NO.	DESCRIPTION
M2R-S	Standard M2 rebuild (also fits M5 thru M9 series)
M2R-P	Premium M2 rebuild (fits M2 series only)
M4R-S	Standard M4 rebuild
M4R-P	Premium M4 rebuild
2VZR-S	Standard ZEPPELIN® 2-valve rebuild (fits both aluminum and brass)
2VZR-P	Premium ZEPPELIN® 2-valve rebuild (fits both aluminum and brass)
4VZR-S	Standard ZEPPELIN® 4-valve rebuild
4VZR-P	Premium ZEPPELIN® 4-valve rebuild

### GAUGE MOUNTING BRACKETS

M2-106	1/8" Female NPT
M2-108	1/4" Female NPT

### ZEPPELIN® BRASS SERIES MANIFOLD

REF NO.	PART NO.	DESCRIPTION
1	MR-601	Handwheel and screw
2	U1-4A	1/4" Intake
3	MR-525	Sight Glass
4	MR-505	Piston With Seat And O-Rings
5	MR-516	Stem And Nut
6	MR-601	Hand Wheel And Screw
7	MR-503	Hand Wheel Screws (Two)
8	MR-509	O-Rings (Two)
9	M2-102N	Hanging Hook

### 2-VALVE ALUMINUM ZEPPELIN®

1	MR-601	Handwheel and screw
2	U1-4A	1/4" Intake
3	MR-525	Sight Glass
4	MR-505	Piston With Seat And O-Rings
5	MR-516	Stem And Nut
6	MR-601	Hand Wheel And Screw
7	MR-503	Hand Wheel Screws (Two)
8	MR-509	O-Rings (Two)
9	M2-102N	Hanging Hook

### 4-VALVE ALUMINUM ZEPPELIN®

1	U1-6B	3/8" Intake
2	U1-4A	1/4" Intake
3	MR-525	Sight Glass
4	MR-605	Piston With Seat And O-Rings
5	MR-607	Stem And Nut
6	MR-601	Hand Wheel And Screw
7	MR-503	Hand Wheel Screws (Two)
8	MR-409	O-Rings (Two)
9	M2-102N	Hanging Hook

# REPAIR

## M2 SERIES

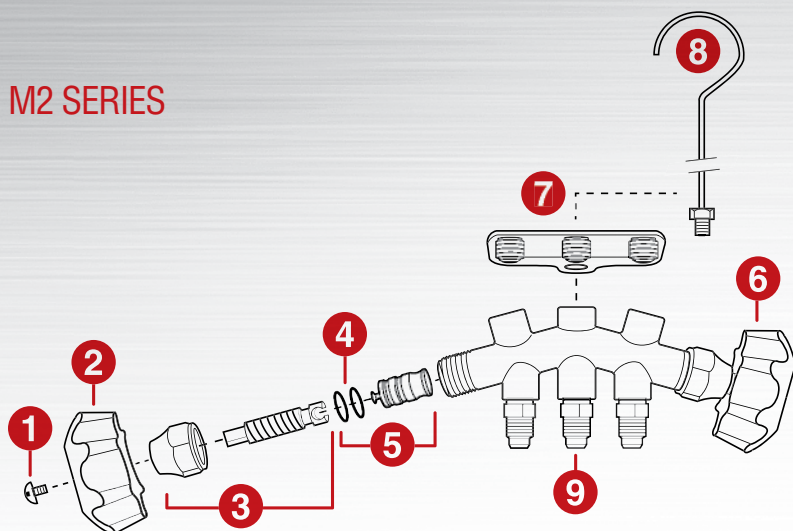

### M2 SERIES MANIFOLDS

REF NO.	PART NO.	DESCRIPTION
1	MR-503	Handwheel Screw (Two)
2	MR-501B	Blue Handwheel And Screw
3	MR-516	Stem And Nut
4	MR-509	O-Ring (Two)
5	MR-505	Piston With Seat And O-Rings
6	MR-501R	Red Handwheel
7	M2-300	Hose Holder
8	M2-102N	Hanging Hook
9	U1-4A	Intake

## M5 - M9 SERIES

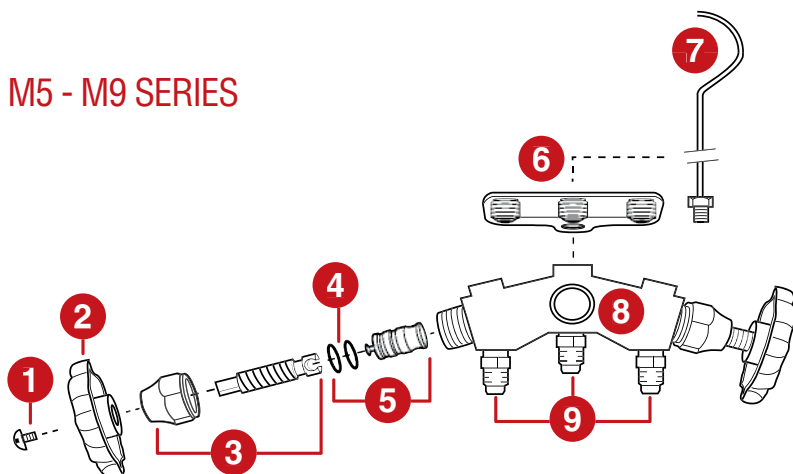

### M5 THROUGH M9 SERIES MANIFOLDS

1	MR-503	Handwheel Screw (Two)
2	MR-508	Metal Handwheel And Screw
3	MR-516	Stem And Nut
4	MR-509	O-Ring (Two)
5	MR-505	Piston With Seat And O-Rings
6	M2-300	Hose Holder
6	MR-521	Acme Thread Hose Holder
7	M2-102N	Hanging Hook
8	MR-525	Sight Glass
9	U1-4A	Intake
9	AF-13450	Acme Intake for automotive application

## PATRIOT™ SERIES

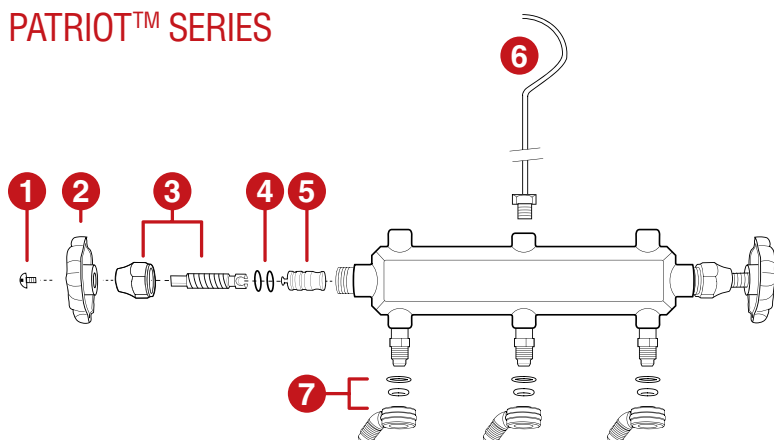

### PATRIOT™ SERIES MANIFOLDS

1	MR-503	Handwheel Screw (Two)
2	MR-508	Metal Handwheel And Screw
3	MR-516	Stem And Nut
4	MR-509	O-Ring (Two)
5	MR-505	Piston With Seat And O-Rings
6	M2-102N	Hanging Hook
7	MR-504	1/4" Hose Holder Sleeve and O-Rings

## M4 SERIES

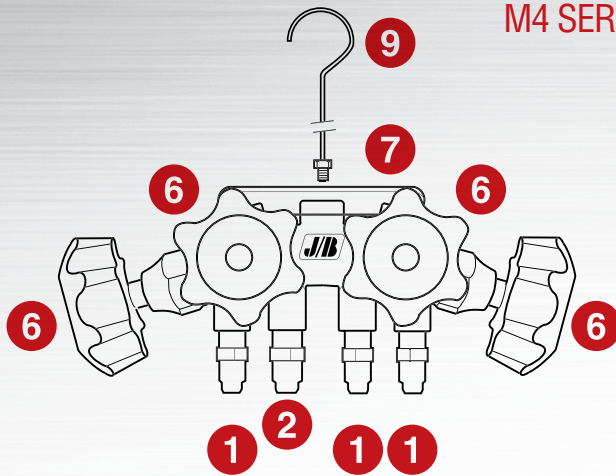

### M4 SERIES MANIFOLD

REF NO.	PART NO.	DESCRIPTION
1	U1-4A	1/4" Intake
2	U1-6A	3/8" Intake
3	MR-505	Piston With Seat And O-Rings
4	MR-516	Stem And Nut
5	MR-503	Handwheel Screws
6	MR-501B	Blue Hand Wheel And Screw
6	MR-501Y	Yellow Handwheel And Screw
6	MR-504B	Black Handwheel And Screw
6	MR-501R	Red Handwheel And Screw
7	MR-531	Hose Holder
8	MR-509	O-Ring (2)
9	M2-102N	Hanging Hook

## BALL-VALVE REVOLVER® SERIES

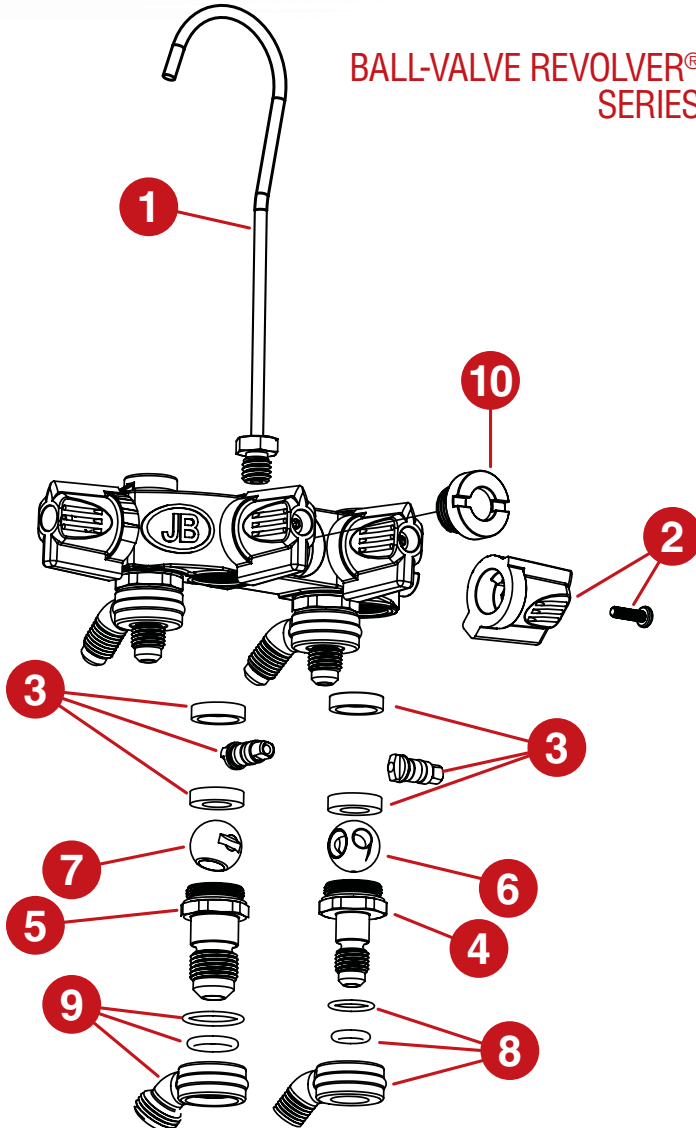

### BALL-VALVE REVOLVER® SERIES MANIFOLD

1	M2-102N	Hanging Hook
2	MR-502	Handle & Screw
3	MR-BVK	Ball Valve Kit Including: (2) Seals, (1) Stem, (2) O-Rings & (1) Washer
4	MR-444	1/4" Retainer Fitting
5	MR-446	3/8" Retainer Fitting
6	MR-611	Throttle Ball
7	MR-610	Ball
8	MR-504	1/4" Hose Holder Sleeve and O-Rings
9	MR-506	3/8" Hose Holder Sleeve and O-Rings
10	MR-525	Sightglass With O-Ring

# INDEX

11175	71	25050	35	27774	41	28574	41	29315	42	113-C3	77
11509	71	25058	35	27776	41	28576	41	29316	42	113-D15	77
11511	71	25065	35	27780	41	28580	41	29317	42	113-D2	77
11575	71	25069	35	27782	41	28582	41	29330	42	113-D25	77
13493	58	25100	35	27784	41	28584	41	29331	42	113-D3	77
13494	58	25108	35	27786	41	28586	41	29332	42	113-D35	77
22125	29	25125	35	27788	41	28588	41	29333	42	116-A	77
22131	29	25133	35	27852	41	28592	41	29335	42	116-B	77
22133	29	25140	35	27854	41	28596	41	29336	42	116-C	77
22225	29	25144	35	27859	41	28597	41	29337	42	116-D	77
22233	29	25150	35	27870	41	28599	41	29338	42	121-A	77
22246	29	25158	35	27872	41	28732	41	29384	42	121-B	77
22500	26-27, 29	25165	35	27874	41	28735	41	29385	42	121-C	77
22505	26-27, 29	25169	35	27880	41	28752	41	29435	67	121-D	77
22525	29	25200	35	27882	41	28754	41	29436	67	121-E	77
22531	29	25208	35	27884	41	28759	41	42019	71	121-F	77
24000	33	25225	35	27886	41	28770	41	96822	71	122-A	77
24008	33	25233	35	27888	41	28772	41	96823	71	122-B	77
24025	33	25240	35	27952	41	28774	41	100-A	77	122-C	77
24033	33	25244	35	27954	41	28776	41	100-B	77	122-D	77
24040	33	25246	35	27959	41	28780	41	100-C	77	122-E	77
24044	33	25250	35	27970	41	28782	41	100-D	77	22225CM	29
24050	33	25258	35	27972	41	28784	41	100-E	77	22225L	29
24058	33	25265	35	27974	41	28786	41	101-A	77	22233CM	29
24065	33	25269	35	27980	41	28788	41	101-B	77	22246CM	29
24069	33	25325	35	27982	41	28832	41	101-C	77	25225L	35
24100	33	25425	35	27984	41	28835	41	101-D	77	26225L	37
24108	33	25500	35	27986	41	28852	41	101-E	77	2VZR-P	83
24125	33	25508	35	27988	41	28854	41	103-A	77	2VZR-S	83
24133	33	25523	35	28102	41	28859	41	103-B	77	33112N	45, 49
24140	33	25525	35	28105	41	28870	41	103-C	77	33112RK	45, 49
24144	33	25533	35	28170	41	28872	41	103-D	77	33113N	45, 49
24150	33	25548	35	28172	41	28874	41	103-E	77	33115N	45, 49
24158	33	25550	35	28174	41	28876	41	110-BA	77	33115RK	45, 49
24165	33	25558	35	28176	41	28880	41	110-CA	77	33116N	45, 49
24169	33	25573	35	28180	41	28882	41	110-CB	77	4VZR-P	83
24200	33	25608	35	28182	41	28884	41	110-DA	77	4VZR-S	83
24208	33	25708	35	28184	41	28886	41	110-DB	77	81LB-4	77
24225	33	25713	35	28186	41	28888	41	110-DC	77	A10971	68
24233	33	26000	37	28188	41	28932	41	110-EA	77	A10972	68
24240	33	26008	37	28192	41	28935	41	110-EB	77	A10973	68
24244	33	26025	37	28196	41	28952	41	110-EC	77	A31002	53
24250	33	26033	37	28197	41	28954	41	110-ED	77	A31003	53
24258	33	26040	37	28199	41	28959	41	110-FD	77	A31004	53
24265	33	26044	37	28202	41	28970	41	110-FE	77	A31004-CJ	56
24325	33	26100	37	28205	41	28972	41	112-A	77	A31004S	53
24425	33	26108	37	28270	41	28974	41	112-B	77	A31005	53
24500	33	26125	37	28272	41	28980	41	112-C	77	A31006	53
24508	33	26133	37	28274	41	28982	41	112-D	77	A31008	53
24525	33	26140	37	28276	41	28984	41	112-E	77	A31009	53
24533	33	26144	37	28280	41	28986	41	113-A15	77	A31011	53
24600	33	26200	37	28282	41	28988	41	113-A2	77	A31012	53
24608	33	26208	37	28284	41	29260	42	113-A25	77	A31234	55
24615	33	26225	37	28286	41	29263	42	113-A3	77	A31235	55
25000	35	26233	37	28288	41	29280	42	113-A35	77	A31236	55
25008	35	26240	37	28292	41	29285	42	113-B15	77	A31238	55
25025	35	26244	37	28296	41	29290	42	113-B2	77	A31424	55
25033	35	26246	37	28297	41	29292	42	113-B25	77	A31434	54
25040	35	27752	41	28299	41	29295	42	113-B3	77	A31444	55
25044	35	27754	41	28502	41	29297	42	113-B35	77	A31452	55
		27759	41	28505	41	29310	42	113-C15	77	A31454	55
		27770	41	28570	41	29311	42	113-C2	77	A31482	55
		27772	41	28572	41	29312	42	113-C25	77	A31484	55



# INDEX

DV-EP8.....81	ES2-88.....73	LDA-VCH.....23	M2-8.....31	MR-594.....43	P2-3.....74
DV-EP8.....82	ES4-1010.....73	LDA-WCH.....23	M2-8-410A.....31	MR-595.....43	P2-4.....74
DV-F6.....13	ES4-1212.....73	LDA-WCHEU.....23	M2-8-410AB.....31	MR-596.....43	P2-5.....74
DV-F8.....13	ES4-44.....73	LDA-WCHUK.....23	M2-800.....42	MR-598.....43	P2-6.....74
DV-T1.....12	ES4-66.....73	LDA-WCHUS.....23	M2-805.....42	MR-601.....83	P2-8.....74
DVO-1.....12	ES4-88.....73	LDA-WE9.....23	M2-808.....40	MR-605.....83	P509.....58-59
DVO-12.....12	EZ-40288.....58	LDA-WTP.....23	M2-810.....42	MR-607.....83	P509-25.....58
DVO-24.....12	EZ-40288-126.....58	LDC-4000.....21	M2-815.....42	MR-610.....85	P511.....46, 49
E1-10C.....73	F6-110-CRD.....15	LDC-4000-1.....21	M2-820.....42	MR-611.....85	P90008.....46, 49
E1-10D.....73	F6-BH.....15	LDC-4000-2.....21	M2-820L.....43	MR-BVK.....85	P90009.....13, 16-19, 48, 58-59, 81
E1-10E.....73	F6-DP.....14-15	LDC-4000-3.....21	M2-825.....42	MSKIT1.....26-27	P90010.....58
E1-12D.....73	F6-FLT.....15	LDC-4000-4.....21	M2-825L.....43	MSKIT1-BAG.....26-27	P90011.....58
E1-12E.....73	F6-RBFT.....15	LDC-4000-5.....21	M2-828.....42	MSKIT2.....26-27	P90012.....13, 48, 59
E1-2A.....73	F6-RH.....15	LT-456.....58	M2-829.....42	MSKIT3.....26-27	P90016.....46, 49
E1-3A.....73	F6-RHP.....15	LT-810.....58	M2-830.....42	N4-10.....74	P90022.....45, 49
E1-4A.....73	F6-STRAP.....15	M2-102N.....83-85	M2-831.....42	N4-12.....74	P90513.....59
E1-4B.....73	FP-A-168.....73	M2-106.....83	M2-851.....42	N4-4.....74	P90514.....46, 49
E1-4C.....73	FP-A-210.....73	M2-108.....83	M2-856.....42	N4-5.....74	PR-1.....81-82
E1-5A.....73	FP-A-283.....73	M2-21125.....31	M2-860.....43	N4-6.....74	PR-10.....82
E1-5B.....73	FP-B-168.....73	M2-21125B.....31	M2-865.....43	N4-8.....74	PR-18.....81-82
E1-5C.....73	FP-B-210.....73	M2-21131.....31	M2-870.....43	N5-10.....74	PR-18.....81-82
E1-6A.....73	FP-B-283.....73	M2-21131B.....31	M2-875.....43	N5-12.....74	PR-2.....81-82
E1-6B.....73	FP-C-168.....73	M2-21525.....31	M2-880.....43	N5-3.....74	PR-200.....81
E1-6C.....73	FP-C-210.....73	M2-21525B.....31	M2-885.....43	N5-4.....74	PR-201.....81
E1-6D.....73	FP-C-283.....73	M2-21531.....31	M2-890.....43	N5-5.....74	PR-205.....81-82
E1-6E.....73	FU-4B-168.....74	M2-21531B.....31	M2-895.....43	N5-6.....74	PR-206.....81-82
E1-8B.....73	FU-4B-210.....74	M2-22125.....31	M2-8B.....31	N5-8.....74	PR-207.....81-82
E1-8C.....73	FU-4B-283.....74	M2-22131.....31	M2-924.....43	NFT5-4 . 26-27, 58, 81-82	PR-208.....81-82
E1-8D.....73	FU-4B-283.....74	M2-22225.....31	M2-924CM.....42	NFT5-4-100.....58	PR-209.....81
E1-8E.....73	FU-4C-168.....74	M2-22231.....31	M2-925.....43	NFT5-4-101.....74	PR-210.....81
E2-10.....73	FU-4C-210.....74	M2-22244.....31	M2-925CM.....42	NFT5-4-CJ.....56	PR-211.....81
E2-12.....73	FU-4C-283.....74	M2-22325.....31	M2-951.....43	NFT5-5.....26-27, 58	PR-215.....81
E2-2.....73	FU-6C-168.....74	M2-22425.....31	M2-956.....43	NFT5-6.....58, 81-82	PR-217.....81-82
E2-3.....73	FU-6C-210.....74	M2-22525.....31	M2-HP.....40	NFT5-6-100.....58	PR-22.....81-82
E2-4.....73	FU-6C-283.....74	M2-22531.....31	M2-HP-5.....40	NFT5-6-101.....74	PR-3.....81-82
E2-5.....73	GTBG-12.....67	M2-23125.....31	M2R-P.....83	NFT5-8.....58, 81	PR-300.....81
E2-6.....73	GTBG-16.....67	M2-23131.....31	M2R-S.....83	NRS4-108.....74	PR-301.....81
E2-8.....73	HNS4-10.....74	M2-23225.....31	M4R-P.....83	NRS4-1210.....74	PR-302.....81
E3-10D.....73	HNS4-12.....74	M2-23231.....31	M4R-S.....83	NRS4-43.....74	PR-303.....81
E3-10E.....73	HNS4-4.....74	M2-250.....42	MR-409.....83	NRS4-54.....74	PR-304.....81
E3-4A.....73	HNS4-6.....74	M2-300.....84	MR-444.....85	NRS4-64.....74	PR-308.....81
E3-4B.....73	HNS4-8.....74	M2-350.....42	MR-446.....85	NRS4-65.....74	PR-31.....81-82
E3-5B.....73	JB-BACKPACK1 . 26-27	M2-355.....42	MR-501B.....84-85	NRS4-86.....74	PR-311.....81
E3-5B.....73	JB-TOOLBAG1 . 26-27	M2-36.....31	MR-501R.....84-85	NS4-10.....74	PR-314.....81
E3-6A.....73	K1-1.....73	M2-36B.....31	MR-501Y.....85	NS4-10-CS.....74	PR-315.....81-82
E3-6B.....73	K1-3.....73	M2-400.....42	MR-502.....85	NS4-12.....74	PR-32.....81
E3-6C.....73	K1-5.....73	M2-405.....42	MR-503.....83-85	NS4-12-CS.....74	PR-35.....81
E3-6D.....73	K1-8.....73	M2-410.....42	MR-504.....84-85	NS4-14.....74	PR-39.....82
E3-8C.....73	K1-D.....74	M2-415.....42	MR-504B.....85	NS4-3.....74	PR-4.....81
E3-8D.....73	K1-E.....74	M2-420.....42	MR-505.....83-85	NS4-4.....74	PR-40.....81-82
E3-8E.....73	LC-4.....59	M2-425.....42	MR-506.....85	NS4-4-CS.....74	PR-403.....82
E4-44.....73	LC-5.....59	M2-430.....42	MR-508.....84	NS4-5.....74	PR-404.....82
E4-66.....73	LD-5000.....20	M2-435.....42	MR-509.....83-85	NS4-6.....74	PR-406.....82
E4-88.....73	LD-6000IR.....22-23	M2-460.....42	MR-516.....83-85	NS4-6-CS.....74	PR-42.....81
ER2-108.....73	LD-CS.....20	M2-465.....42	MR-517.....43	NS4-8.....74	PR-45.....81
ER2-64.....73	LD-PK.....20	M2-5.....31	MR-521.....84	NS4-8-CS.....74	PR-5.....81
ER2-84.....73	LD-RF5.....20	M2-5-410A.....31	MR-525.....83-85	NST4-10.....74	PR-500.....81-82
ER2-86.....73	LD-S100.....20	M2-5-410A-SS.....31	MR-531.....85	NST4-4.....74	PR-501.....81
ES2-44.....73	LD-S101.....20	M2-5-410AB.....31	MR-533.....43	NST4-6.....74	PR-501.....82
ES2-66.....73	LD-TV.....20	M2-500.....42	MR-590.....43	NST4-8.....74	PR-52.....81
ES2-68.....73	LDA-LI.....23	M2-5B.....31	MR-593.....43	NV62-4.....61	PR-54.....81-82
	LDA-NNP4.....23	M2-6.....31	MR-593CM.....43	P2-10.....74	PR-56.....81
	LDA-NNP9.....23	M2-6B.....31	MR-593SP.....43	P2-12.....74	PR-58.....81-82
	LDA-PK.....23				PR-59.....81-82



# INDEX

PR-6.....81-82	RT70015.....62	T2-4.....19, 74	TR2-664.....74	U4-4.....76	V34201.....60
PR-62.....81-82	RT70017B.....62-63	T2-5.....74	TR2-668.....74	U4-6.....76	V34202.....60
PR-63.....82	RT70017D.....62-63	T2-6.....74	TR2-886.....74	U4-8.....76	V34203.....60
PR-65.....82	RT70020.....62	T2-8.....74	TRQ-IMP.....26-27,64	U5-4A.....76	V34204.....60
PR-7.....81	RT70021.....62	T20095.....66	TRQ1075.....26-27,64	U5-4B.....76	V34206.....60
PR-75.....81	RT70027.....62	T20195.....65	TRQ1080.....26-27,64	U5-6B.....76	V34207.....60
PR-76.....81	RT70029.....62	T20203.....65	U1-10B.....75	U5-8C.....76	V34208.....60
PR-77.....81-82	RT70030.....63	T20275.....66	U1-10C.....75	U5-8D.....76	V34209.....60
PS-10.....67	RT70041.....62	T20351.....64	U1-10D.....75	U6-4A.....76	V34210.....60
PS-100.....67	RT70056D.....62	T20352.....64	U1-10E.....75	U6-4B.....76	V34211.....60
PS-25.....67	RT70057D.....63	T20353.....64	U1-12C.....75	UR2-106.....75	V34300.....61
PS-50.....67	RT70075.....63	T20500.....65	U1-12D.....75	UR2-108.....75	V34301.....61
QC-13445-134A.....70	RT70105.....62	T21000.....66	U1-12E.....75	UR2-1210.....75	V34302.....61
QC-E3.....59	RT70142.....63	T21002.....66	U1-14E.....75	UR2-128.....75	V34303.....61
QC-E4.....59	RT70401.....62	T21003.....66	U1-2A.....75	UR2-43.....75	V34304.....61
QC-E5.....59	RT70402.....62	T21004.....66	U1-3A.....75	UR2-54.....75	V34306.....61
QC-E64.....13, 59	RT70521.....62	T21005.....66	U1-3B.....75	UR2-64.....75	V34307.....61
QC-G430.....43	RT70522.....62	T21006.....66	U1-4A.....75, 83-85	UR2-65.....75	V34308.....61
QC-G434.....43	RT70523.....62	T21007.....66	U1-4B.....75	UR2-84.....75	V34309.....61
QC-G460.....43	RT70531.....63	T21008.....66	U1-4C.....75	UR2-86.....75	V34310.....61
QC-G465.....43	RT70532.....63	T21010.....66	U1-4D.....75	UR3-1012.....75	V34311.....61
QC-G820.....43	RT70533.....63	T21012.....66	U1-5A.....75	UR3-108.....75	V34350.....61
QC-G825.....43	RT70558.....63	T21014.....66	U1-5B.....75	UR3-1210.....75	V34400.....60
QC-G851.....43	RT90614.....64	T21018.....66	U1-5C.....75	UR3-43.....75	V34401.....60
QC-G856.....43	RT99016.....62	T21024.....66	U1-6A.....75, 85	UR3-46.....75	V34402.....60
QC-S3.....59	SHLD-3-DRIVER.....51	T21124U.....67	U1-6B.....75, 83	UR3-48.....75	V34404.....60
QC-S4.....59	SHLD-8-DRIVER.....51	T21125U.....67	U1-6C.....75	UR3-64.....75	V34406.....60
QC-S46.....59	SHLD-BIT.....51	T21126U.....67	U1-6D.....75	UR3-68.....75	V34407.....60
QC-S4A.....59	SHLD-CJ.....51	T21127.....67	U1-6E.....75	UR3-810.....75	V34408.....60
QC-S4A-134A.....70	SHLD-COMBO -DRIVER.....51	T21127U.....67	U1-8A.....75	UR3-84.....75	V34409.....60
QC-S4B.....59	SHLD-E12.....50	T21294.....66	U1-8B.....75	UR3-86.....75	V34500.....61
QC-S5.....59	SHLD-E4.....26-27,50-51	T21295.....45, 49	U1-8C.....75	US3-1010.....75	V34501.....61
QC-S5S.....59	SHLD-E50.....50	T3-10D.....75	U1-8D.....75	US3-1012.....75	V34502.....61
QC-S64.....13, 59	SHLD-G12.....50	T3-4A.....75	U1-8E.....75	US3-1014.....75	V34504.....61
QC-S65.....59	SHLD-G4.....50	T3-4B.....75	U2-10.....75	US3-108.....75	V34506.....61
REC-TANK.....15	SHLD-G50.....50	T3-5B.....75	U2-12.....75	US3-1212.....75	V34507.....61
RT11006.....63	SHLD-G50.....50	T3-6B.....75	U2-14.....75	US3-1214.....75	V34508.....61
RT12318.....65	SHLD-MULTI.....51	T3-6C.....75	U2-2.....75	US3-44.....75	V34509.....61
RT16001.....65	SHLD-P12.....50	T3-6D.....75	U2-3.....75	US3-45.....75	V34510.....61
RT16101.....65	SHLD-P4.....26-27,50-51	T3-8C.....75	U2-4.....75	US3-46.....75	V34511.....61
RT21652B.....62-63	SHLD-P4.....50	T3-8D.....75	U2-5.....75	US3-610.....75	V34525.....61
RT21655.....63	SHLD-P50.....50	T30251.....67	U2-6.....75	US3-64.....75	V34900.....61
RT21660.....63	SHLD-SLG20.....51	T30600.....26-27,65	U2-8.....75	US3-65.....75	V34901.....61
RT22124.....65	SHLD-SLP20.....51	T30605.....26-27	U3-10C.....75	US3-66.....75	V34905.....61
RT222402.....65	SHLD-SLU20.....51	T6-4.....75	U3-10D.....75	US3-68.....75	
RT222601.....65	SHLD-U100.....50	TC-100-10.....68	U3-10E.....75	US3-810.....75	
RT23022.....64	SHLD-U12.....50	TC-26-16.....68	U3-2A.....75	US3-86.....75	
RT25131.....64	SHLD-U4.....50	TC-31-12.....68	U3-3A.....75	US3-88.....75	
RT25136.....64	SHLD-U50.....50	TC-36-12.....68	U3-4A.....75	US4-10.....76	
RT25140.....64	T1-10C.....74	TC-42-12.....68	U3-4B.....75	US4-4.....76	
RT25142.....64	T1-10D.....74	TC-44-12.....68	U3-4C.....75	US4-5.....76	
RT25151.....63	T1-4A.....74	TC-49-11.....68	U3-5A.....75	US4-6.....76	
RT25913.....64	T1-4B.....74	TC-50-11.....68	U3-5B.....75	US4-8.....76	
RT25914.....64	T1-4C.....74	TC-54-11.....68	U3-6A.....75	US5-1010.....76	
RT26036.....65	T1-5B.....74	TC-55-11.....68	U3-6B.....75	US5-1212.....76	
RT26715.....65	T1-6B.....74	TC-59-10.....68	U3-6C.....75	US5-44.....76	
RT52000.....63	T1-6C.....74	TC-64-10.....68	U3-6D.....75	US5-66.....76	
RT52010.....63	T1-6D.....74	TC-70-12.....68	U3-8B.....75	US5-88.....76	
RT52011.....63	T1-8B.....74	TC-75-9.....68	U3-8C.....75	UX1-4A.....76	
RT52030.....63	T1-8C.....74	TC-80-10.....68	U3-8D.....75	UX1-4B.....76	
RT52042.....63	T1-8D.....74	TC-85-9.....68	U3-8E.....75	UX2-4.....76	
RT70007B.....62	T2-10.....74	TC-90-7.....68	U4-10.....76	V34010.....61	
RT70007X.....62	T2-12.....74	TR2-446.....74	U4-12.....76	V34200.....60	
	T2-3.....74				

# JB INTERNATIONAL SALES CONTACTS

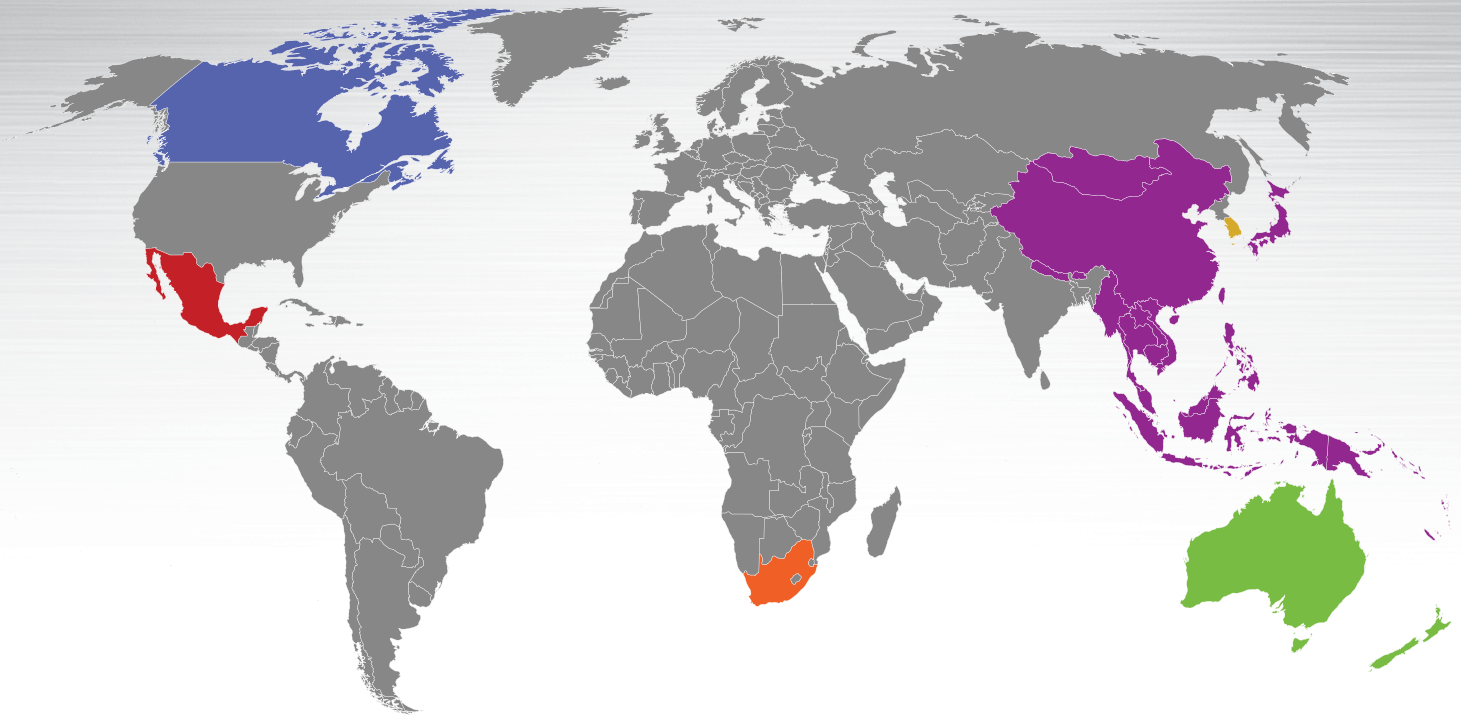

## WILDON SALES AND MARKETING, INC.

Bill Northam  
**Territory:** CANADA  
(Oshawa, Ontario, Canada)  
**P:** 905.432.6822  
**E:** bdnortham@rogers.com

## JB INDUSTRIES, INC.

Jonathan Brenis  
**Territory:** MEXICO  
**P:** 216.214.2647  
**E:** jonb@jbind.com

## QFC USA INC.

Andrew Uy  
**Territory:** SOUTH KOREA  
**P:** 909.627.7488  
**E:** qfcusa@gmail.com

## ALLTEMP PRODUCTS CO, LTD.

**Territory:** CANADA  
(Pickering, Ontario, Canada)  
**P:** 800.263.4624  
**E:** sales@alltemp.ca

## MRE INTERNATIONAL CORP.

Shepard Goodman  
(Pacific Palisades, CA USA)  
**Territory:** FAR EAST  
**P:** 310.459.1333  
**F:** 310.459.5740  
**E:** acexporter@aol.com

## COMARTCO

Dong Yeol Lee  
**Territory:** SOUTH KOREA  
**P:** 822.858.0051  
**E:** comartco@naver.com

## PRO PIPE SUPPLIES PTY. LTD.

Brett Spicer  
**Territory:** AUSTRALIA, NEW ZEALAND  
**P:** 088.186.4666  
**E:** brett@propipesupplies.com.au

## KRUEGER & KRUEGER

Urnie Krueger  
**Territory:** SOUTH AFRICA  
**P:** 630.561.5745  
**E:** ukrueger@sbcglobal.net

## INTERNATIONAL CONTACT

### JB INDUSTRIES, INC.

Doug Groberg  
**Territory:** WORLDWIDE  
**P:** +630.851.9444  
**E:** dgroberg@jbind.com

JB continues to look for international partners. Please send inquiries to our Global Manager Doug Groberg at [dgroberg@jbind.com](mailto:dgroberg@jbind.com)

# JB DOMESTIC SALES CONTACTS

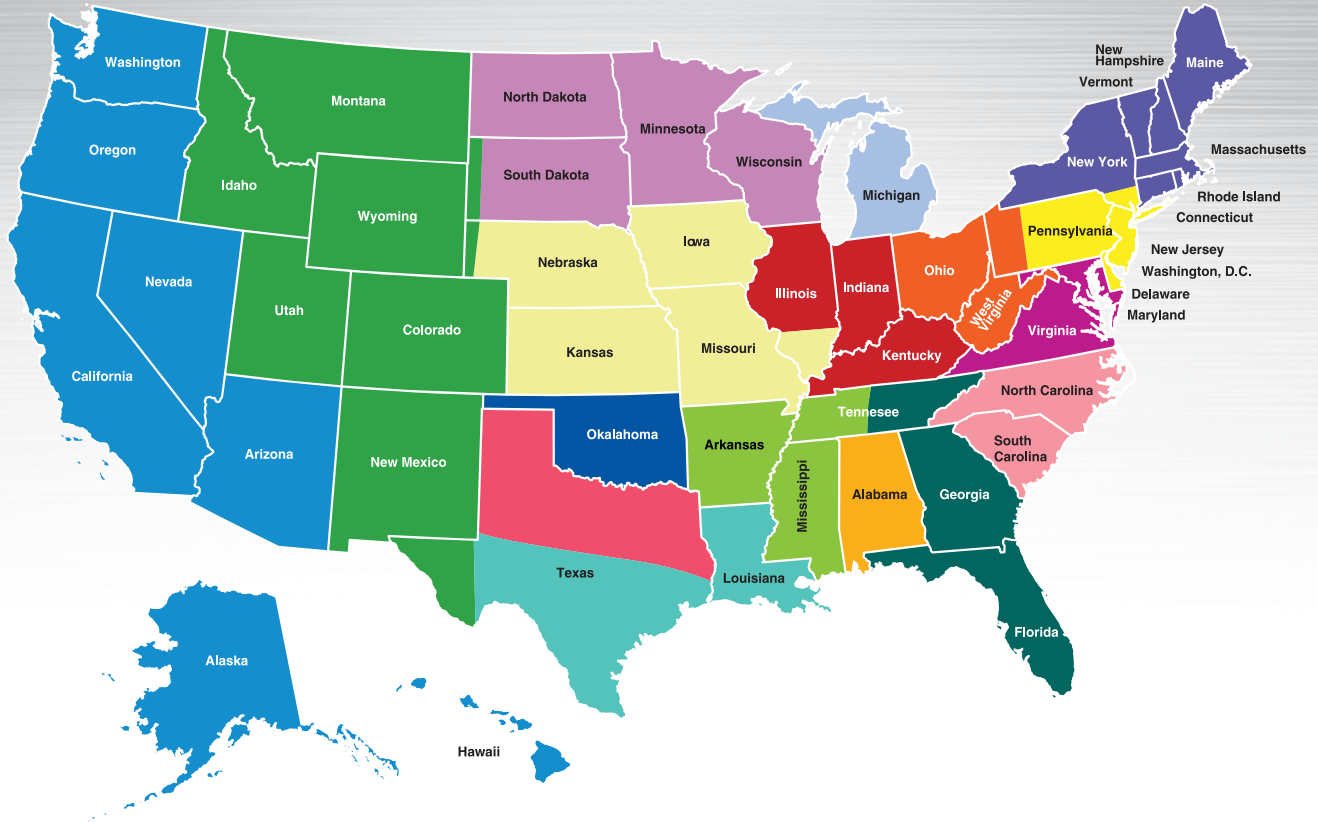

**OSCAR LOPEZ**  
VICE PRESIDENT OF SALES  
P: 817.366.0903  
E: oscar@jbind.com

**JENNY HONN**  
DIRECTOR OF SALES  
P: 404.849.0371  
E: jhonn@jbind.com

**TOM MUNCEY**  
REGIONAL SALES MANAGER  
P: 847.922.7480  
E: tmuncey@jbind.com

**GIMPER IV, LLC.**  
Dan Clark  
P: 518.885.8901  
E: Gimper2@aol.com

**CHRISTIAN & COMPANY**  
Jeff Christian  
P: 248.851.5660  
E: jjchvac@aol.com

**SUPERIOR SALES & SERVICE**  
Mike Lochridge  
P: 832.418.1412  
E: m.loch@earthlink.net

**BIRDSONG & ASSOCIATES**  
Bill Birdsong  
P: 732.854.9609  
E: BirdsongNJ@aol.com

**RAC SALES**  
Brad Rinderknecht  
P: 763.785.7000  
E: racsales@racsalesinc.com

**MJM ASSOCIATES INC.**  
Camden Marklowitz  
P: 303.790.7000  
E: cmarklowitz@mjmassoc.com

**ROBERT H HESTER LLC**  
Robert Hester  
P: 540.336.3940  
E: rhh71@msn.com

**CENTRAL STATES MARKETING**  
William J. Hosner  
P: 314.517.3002  
E: billh@csmktg.co

**WESTERN COMPONENT SALES**  
George Kief  
P: 888.927.2248 x102  
E: george@westerncomponentsales.com

**RHODES & STAFFORD**  
Rick Stafford  
P: 336.273.0505  
E: rstafford@rhodesandstafford.com

**RIDDELL ENTERPRISES LTD.**  
Bill Riddell  
P: 918.625.0360  
E: reltd@sbcglobal.net

Corey Smith  
P: 888.927.2248 x105  
E: corey@westerncomponentsales.com

**LEONE GREEN & ASSOCIATES**  
Frank Leone  
P: 800.843.6034  
E: sales@leonegreen.com

**SARRIO SALES, INC**  
Barry Sarrio  
P: 901.854.5004  
E: Barry@sarriosales.com

**THE EBY COMPANY**  
Chris Eby  
P: 440.232.1144  
E: sales@theebyco.com

# JB INDUSTRIES

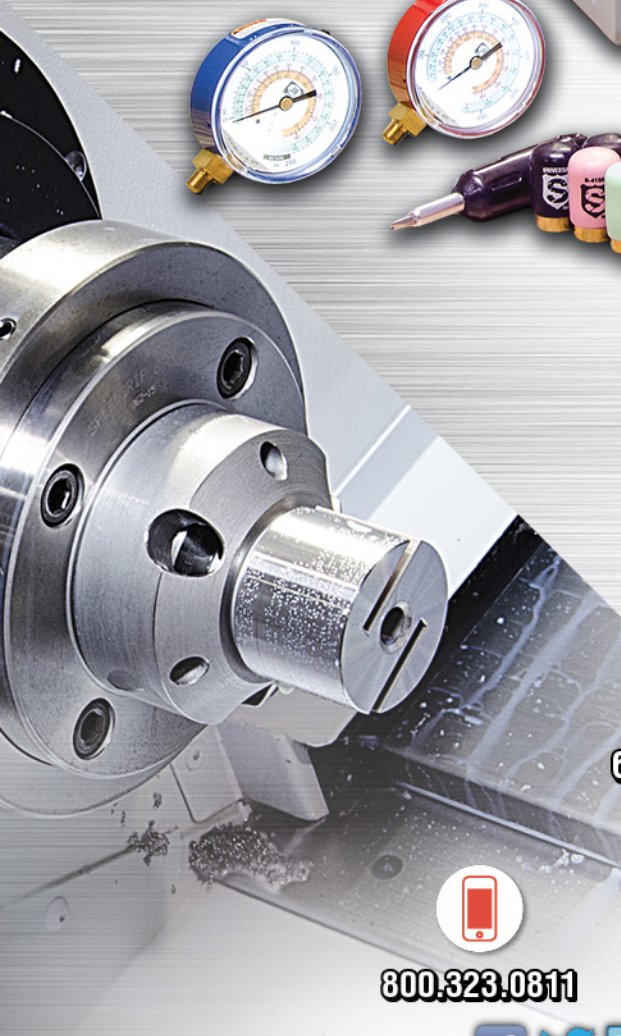

601 N. FARNSWORTH AVE.  
AURORA, IL 60505



800.323.0811



SALES@JBIND.COM



800.552.5593



WWW.JBIND.COM