

INSTALLATION INSTRUCTIONS

TWINNING KIT

NAHA00601WK

Please read these instructions completely before starting the installation.

SAFETY CONSIDERATIONS

Improper installation, adjustment, alteration, service, maintenance, or use can cause explosion, fire, electrical shock, or other conditions which may cause death, personal injury, or property damage. Consult a qualified installer, service agency, or your distributor or branch for information or assistance. The qualified installer or agency must use factory-authorized kits or accessories when modifying this product. Refer to the individual instructions packaged with the kits or accessories when installing.

Follow all safety codes. Wear safety glasses, protective clothing, and work gloves. Have a fire extinguisher available. Read these instructions thoroughly and follow all warnings or cautions include in literature and attached to the unit. Consult local building codes, the current editions of the National Fuel Gas Code (NFGC) NFPA 54/ANSI Z223.1 and the National Electrical Code (NEC) NFPA 70.

Recognize safety information. This is the safety-alert symbol . When you see this symbol on the unit and in instructions or manuals, be alert to the potential for personal injury.

Understand the signal words **DANGER**, **WARNING**, and **CAUTION**. These words are used with the safety-alert symbol. **DANGER** identifies the most serious hazards which **will** result in severe personal injury or death. **WARNING** signifies hazards which **could** result in personal injury or death. **CAUTION** is used to identify unsafe practices which **may** result in minor personal injury or product and property damage. **NOTE** is used to highlight suggestions which **will** result in enhanced installation, reliability, or operation.

TABLE OF CONTENTS

Safety Considerations	1
Table of Contents	1
Introduction	1
Description and Usage	1
Kit Contents	3
Electrostatic Discharge (ESD) Precaution	3
Single-Speed and Two-Speed Non-Condensing ...	4
Install Furnaces	4
Dimensions	5
Connect Electrical Components – Heating	10
Connect Electrical Components – Cooling	14
Venting	14
Gas Supply Piping	14
Electrical Supply Connections	14
START-UP AND ADJUSTMENT	15
SEQUENCE OF OPERATION	18

WARNING

ELECTRICAL OPERATION HAZARD

Failure to follow this warning could result in personal injury or death.

Turn off gas and electrical supplies to unit before beginning any installation or modification. Follow operating instructions on label attached to furnace.

CAUTION

CUT HAZARD

Failure to follow this caution may result in personal injury.

Sheet metal parts may have sharp edges or burrs. Use care and wear appropriate protective clothing and gloves when handling parts.

INTRODUCTION

IMPORTANT: Only the furnace sizes listed in Table 2 can be twinned. Both furnaces must have the same product number, including heating and cooling sizes, to achieve correct operation.

This furnace twinning kit permits connection to the following furnaces to operate as a single unit on the same duct work:

- Two multipoise, 33.3 inch (846 mm), single-speed, non-condensing furnaces (See Figure 1, Figure 2 and Table 2)
- Two multipoise, 33.3 inch (846 mm), two-stage, non-condensing furnaces (See Figure 1, Figure 14, and Table 2)

WARNING

UNIT AND PROPERTY DAMAGE HAZARD

Failure to follow this warning could result in unit and property damage.

A non-condensing furnace shall NOT be twinned with a condensing furnace. Two-stage condensing or non-condensing furnaces shall not be twinned with any single stage furnace. Do not twin furnaces that have a different number of blower motor speed taps together. Furnaces shall only be twinned in the positions shown. Variable-speed furnaces shall not be twinned.

DESCRIPTION AND USAGE

Refer to the appropriate section for your furnaces.

SECTION I: Models N8MSN & N8MSL Multipoise Single-Speed Non-Condensing HSI Furnaces

- Single-Stage Heat with Single-Stage Gas-Heat Thermostat
- Two-Stage Heat with Two-stage Gas-Heat Thermostat

Models F8MTL & G8MTL Multipoise Two-Stage Non-Condensing HSI Furnaces

- Two-Stage Heat with Single-Stage Gas-Heat Thermostat
- Two-Stage Heat with Two-Stage Gas-Heat Thermostat

DUCT CONNECTIONS

All furnaces must have a common supply plenum attached to the furnaces or evaporator coils prior to any branch supply trunk or take-off. The height of the plenum should be at least as high (upflow/downflow) or as long (horizontal) as the width of one furnace. Supply air dampers, when used should be installed in the branch ducts, not in the common plenum. Fire or smoke dampers, when required by code may be installed in the common plenum. Refer to the damper manufacturer's ratings installation instructions for proper application. The damper should not create undue restriction in the open position.

All furnaces must be installed to ensure sufficient return air to both furnaces:

- **For upflow furnaces:** A combination of one full side of each and bottom inlet plenum or bottom only inlet plenum shall be used for return air to each furnace. The preferred method is to have all return air brought into the bottom of the furnaces through a common bottom plenum. The bottom return-air plenum shall be at least as high as the width of the furnace bottom return-air opening. When there are height limitations, the bottom return-air plenum height can be reduced to 8 in. minimum (203mm) if one entire side return-air opening of each furnace is used in conjunction with the bottom return opening. Rear inlet plenums shall not be used. (See Figure 1) Connect all return trunks or branch return ducts to common return plenum.
- **For downflow and horizontal furnaces:** All return air must be brought into the bottom opening of the furnace through a

common return air plenum. The return-air plenum shall be at least as long (horizontal) or tall (downflow) as the width of the furnace return-air opening. (See Figure 2) Connect all return trunks or branch return ducts to common return plenum.

- **For all furnaces:** Fire or smoke dampers, when required by code may be installed in the common return plenum. Refer to the damper manufacturer's ratings installation instructions for proper application. The damper should not create undue restriction in the open position.



WARNING

FIRE HAZARD

Failure to follow this warning could result in improper auxiliary limit operation, fire, personal injury or death.

Do not remove the center return-air partitions between the furnaces.

Staged heating operation is permitted only with this twinning kit. With the single-speed, non-condensing furnaces, the left-hand furnace is used for first-stage heat, and both furnaces are used for second-stage heat. With the two-stage, non-condensing furnaces, low-gas heat in both furnaces is used for first-stage heat, and high-gas heat in both furnaces is used for second-stage heat. This kit ensures both furnace blowers operate simultaneously so air flows through the duct work rather than recirculating in a loop between the furnaces.

Figure 1 – Upflow Ductwork Connections

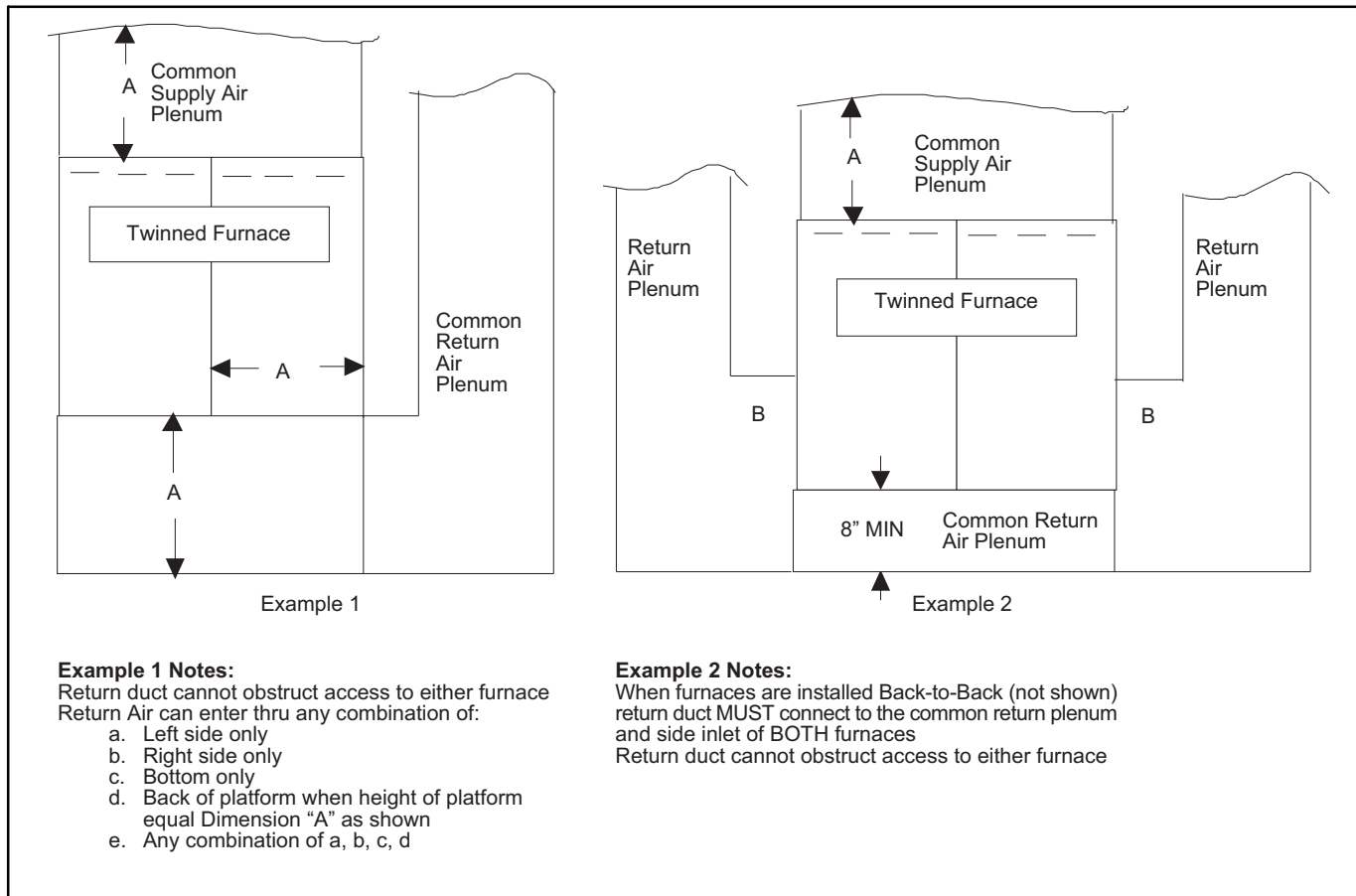

A02223

Figure 2 – Downflow/Horizontal Ductwork Connections

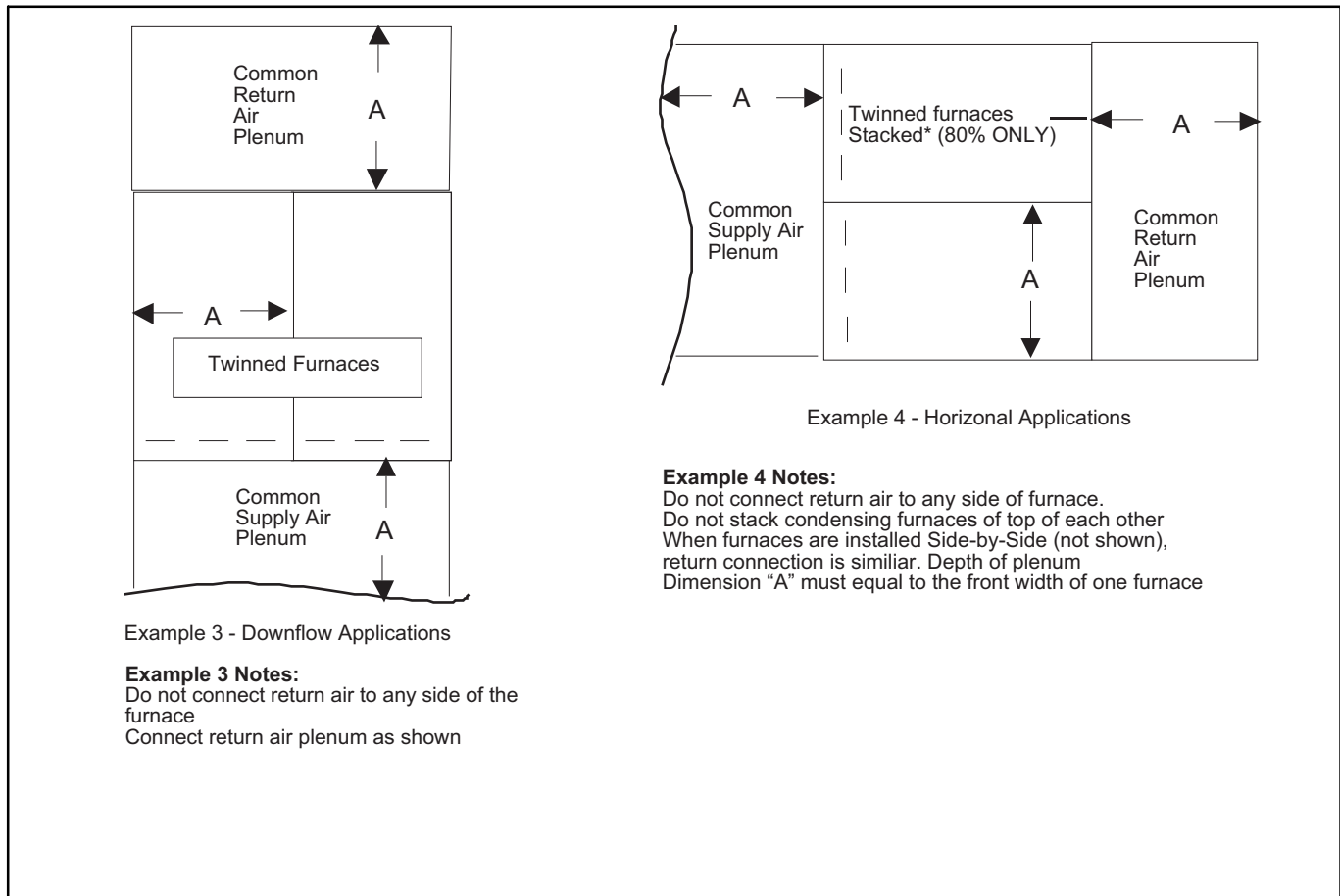

Table 1 – Kit Contents

DESCRIPTION	PART NO.	QTY
Sealing tape		2
External extension harness	327962-701	1
Main twinning harness	327957-701	1
Secondary twinning harness	327959-701	1
Two-stage furnace wiring diagram	337068-101	1
Single stage furnace heat wiring diagram	337070-101	1
Single stage furnace/two-stage heat wiring diagram	337069-101	1
Label	327956-101	1
Tape		1
Bag Assembly includes:		
Snap bushing		2
Screws (HEX HD 6B X 3/4)		10
Screws (flat head)		1
Wire tie		4
Clamps		2
Installation Instructions		1
Auxiliary door switch bracket		1

NOTE: As a result of staged heating with single-speed furnaces, the air temperature distribution in the supply plenum may be uneven when only 1 furnace is heating.

NOTE: Refer to the Installation, Start-Up, and Operating Instructions supplied with each furnace for information on venting, clearances, start-up, maintenance, and other information not covered in this publication.

See Table 1 for kit contents.

ELECTROSTATIC DISCHARGE (ESD) PRECAUTION

⚠ CAUTION

UNIT DAMAGE HAZARD

Failure to follow this caution may result in unit and component damage.

Failure to follow this caution could result in unit and component damage. Electrostatic discharge can affect electronic components. Take precautions during furnace installation and servicing to protect the furnace electronic control. Precautions will prevent electrostatic discharges from personnel and hand tools which are held during the procedure. These precautions will help to avoid exposing the control to electrostatic discharge by putting the furnace, the control, and the person at the same electrostatic potential.

1. Disconnect all power to the furnace. DO NOT TOUCH THE CONTROL OR ANY WIRE CONNECTED TO THE CONTROL PRIOR TO DISCHARGING YOUR BODY'S ELECTROSTATIC CHARGE TO GROUND.
2. Firmly touch a clean, unpainted, metal surface of the furnace chassis which is close to the control. Tools held in a person's hand during grounding will be satisfactorily discharged.
3. After touching the chassis you may proceed to service the control or connecting wires as long as you do nothing that recharges your body with static electricity (for example; DO NOT move or shuffle your feet, DO NOT touch ungrounded objects, etc.).

4. If you touch ungrounded objects (recharge your body with static electricity), firmly touch furnace again before touching control or wires.
5. Use this procedure for installed and uninstalled (ungrounded) furnaces.
6. Before removing a new control from its container, discharge your body's electrostatic charge to ground to protect the control from damage. If the control is to be installed in a furnace, follow items 1 through 5 before bringing the control or yourself into contact with the furnace. Put all used AND new controls into containers before touching ungrounded objects.

7. An ESD service kit (available from commercial sources) may also be used to prevent ESD damage.

SECTION I: MULTIPOISE SINGLE-SPEED AND TWO-SPEED NON-CONDENSING HSI FURNACE MODELS

SINGLE-STAGE	TWO-STAGE
N8MSN	F8MTL
N8MSL	G8MTL

Figure 3 – Dimensional Drawing

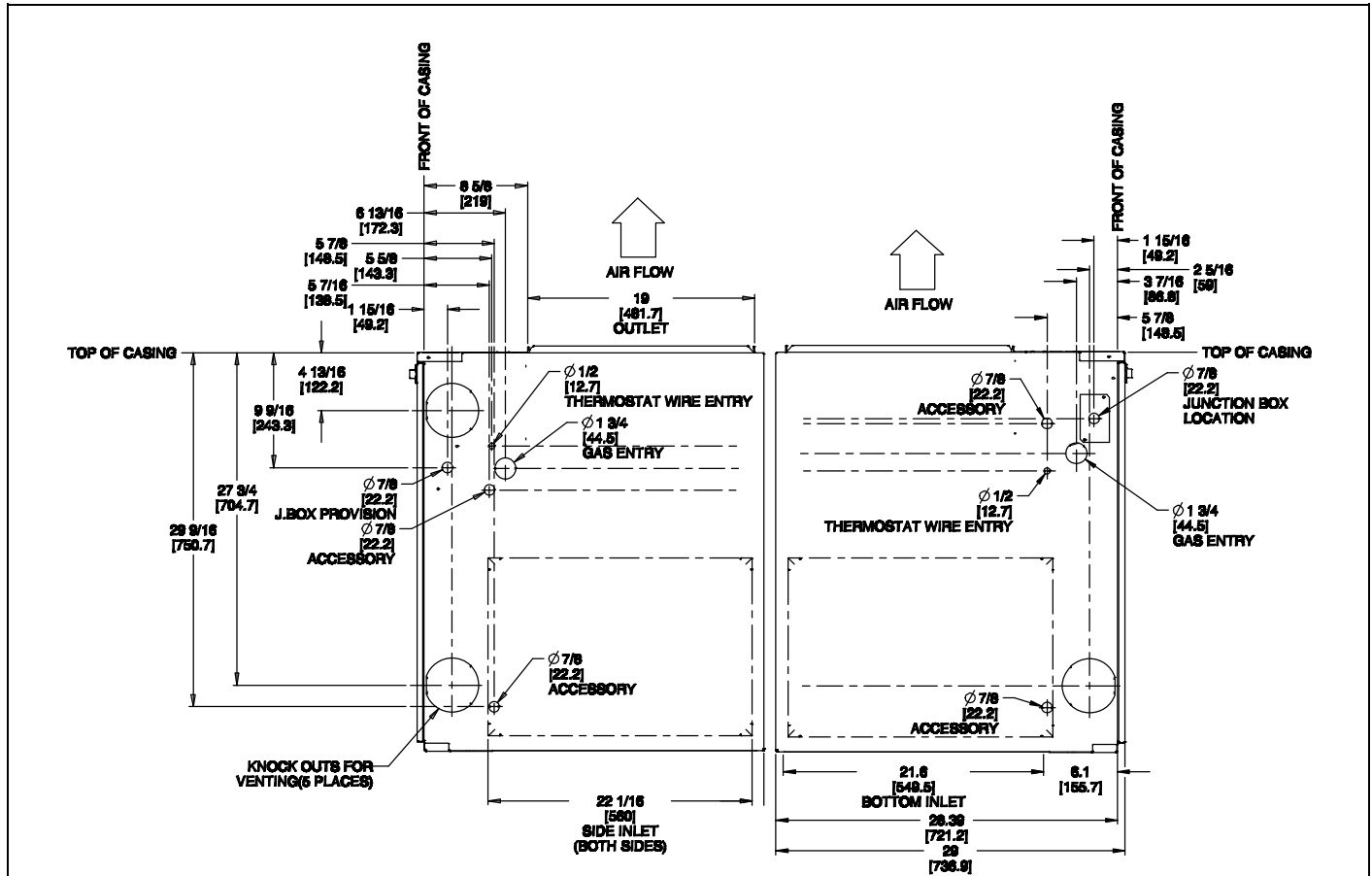

NOTE: Throughout these instructions, when the furnace installed side-by-side, the left-hand (LH) side will be referred to as the LH furnace, and the furnace installed on the right-hand (RH) side as the RH furnace. When the furnaces are installed back-to-back, the left-hand (LH) side will be referred to as the LH furnace, and the furnace installed on the right-hand (RH) side as the RH furnace when viewed from the side with the extension harness installed.

PROCEDURE 1 — INSTALL FURNACES

A. Upflow/Downflow, Side-by-Side Position

Refer to Figure 3 and Table 2 for appearance and dimensional drawing of twinned furnaces and their connection locations.

1. Select 2 identical heating and airflow furnaces. (See Table 2.)
2. Remove outer door and blower access door.
3. For upflow and downflow applications:
 - a. For **upflow** applications: Bottom return air usage is required as part of any upflow return air

configuration. If additional return air is to enter 1 side of each furnace, in addition to bottom return air, cut open 1 entire return-air opening in appropriate side of each furnace. (See Figure 1)

⚠ WARNING

UNIT DAMAGE AND FIRE HAZARD

Failure to follow this warning could result in fire, personal injury or death.

DO NOT use the back of the furnace for return-air duct connections, as limit cycling will occur.

b. For **downflow** applications:

Return air can only be connected to bottom opening of furnace. A common return air plenum is required for proper auxiliary limit switch operation. (See Figure 2)

Table 2 – Dimensions – in. (mm) for Single Stage and Two-Stage with PSC Blower

FURNACE SIZE N8MSN & N8MSL	A	B	C	D	VENT CONNECTION SIZE* IN (mm)	SHIP WT LB (KG)
	CABINET WIDTH IN (mm)	OUTLET WIDTH IN (mm)	TOP AND BOTTOM FLUE COLLAR IN (mm)	BOTTOM WIDTH IN (mm)		
0451408	14-3/16 (360)	12-9/16 (319)	9-5/16 (237)	12-11/16 (322)	4 (102)	104 (47)
0451412	14-3/16 (360)	12-9/16 (319)	9-5/16 (237)	12-11/16 (322)	4 (102)	107 (49)
0701408	14-3/16 (360)	12-9/16 (319)	9-5/16 (237)	12-11/16 (322)	4 (102)	111 (50)
0701412	14-3/16 (360)	12-9/16 (319)	9-5/16 (237)	12-11/16 (322)	4 (102)	115 (52)
0701716	17-1/2 (445)	15-7/8 (403)	11-9/16 (294)	16 (406)	4 (102)	126 (57)
0901714	17-1/2 (445)	15-7/8 (403)	11-9/16 (294)	16 (406)	4 (102)	127 (58)
0902116	21 (533)	19-3/8 (492)	13-5/16 (338)	19-1/2 (495)	4 (102)	140 (64)
0902120	21 (533)	19-3/8 (492)	13-5/16 (338)	19-1/2 (495)	4 (102)	146 (66)
1101712	17-1/2 (445)	15-7/8 (403)	11-9/16 (294)	16 (406)	4 (102)	135 (61)
1102116	21 (533)	19-3/8 (492)	13-5/16 (338)	19-1/2 (495)	4 (102)	146 (66)
1102122	21 (533)	19-3/8 (492)	13-5/16 (338)	19-1/2 (495)	4 (102)	152 (69)
1352116	21 (533)	19-3/8 (492)	13-5/16 (338)	19-1/2 (495)	4 (102)*	149 (68)
1352422	24-1/2 (622)	22-7/8 (581)	15-1/16 (383)	23 (584)	4 (102)*	163 (74)
1552420	24-1/2 (622)	22-7/8 (581)	15-1/16 (383)	23 (584)	4 (102)*	170 (77)

*5-in. or 6-in. (127 or 152 mm) vent connector may be required in some cases.

*135 and 155 size furnaces require a 5 or 6-in. (127 or 152 mm) vent. Use a vent adapter between furnace and vent stack. See Installation Instructions for complete installation requirements.

⚠ WARNING

UNIT DAMAGE AND FIRE HAZARD

Failure to follow this warning could result in unit damage, fire, personal injury or death.

DO NOT use the back or sides of the furnace for return-air duct connections in downflow position, as limit switch cycling will occur.

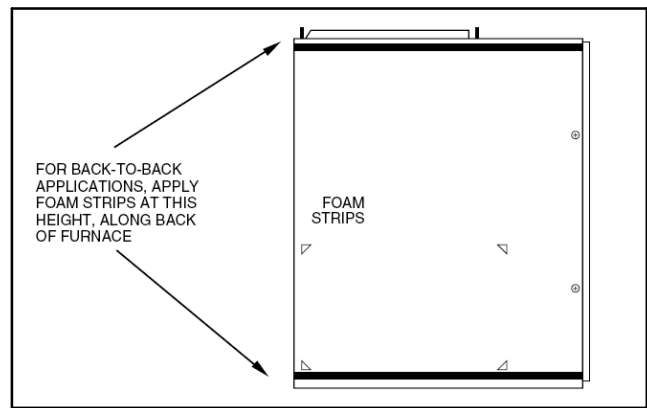

Figure 5 – Location of Foam Strips

4. Remove bottom closure panels from both furnaces. (See Figure 4)
 - a. Lay furnaces on back or sides.
 - b. Remove 2 screws from bottom front panel.
 - c. Pull front panel forward to remove.
 - d. Remove bottom closure panel and discard.
 - e. Reinstall bottom front panel.
 - f. Stand furnaces upright.
5. Apply 2 factory-supplied foam strips to mating side of each furnace. Locate strips equal distance from top and bottom as shown in Figure 5. Trim off excess material.
6. Remove 7/8-in. diameter accessory hole knock-outs in blower compartment from mating sides of furnaces. (See Figure 3)

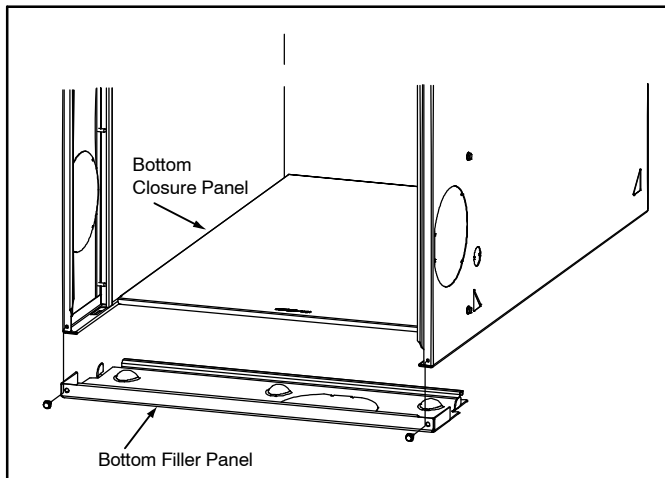

Figure 4 – Removing Bottom Closure Panel

7. Insert a plastic snap bushing through the 7/8-in. knock-out from the outside of the casing.
8. Bend or remove the supply flanges as required for upflow or downflow installation. Refer to the furnace installation instructions for complete details.
9. Position furnaces against each other on return air plenum, supply air plenum or evaporator coil casing. Adjust and shim each furnace to align 7/8-in. diameter holes in both furnaces.
10. Drill two 1/8-in. holes, approximately 1 in. (25 mm) below discharge flange, from inside top of discharge opening and through both furnaces. (See Figure 6) Drill two 1/8-in. holes, approximately 1 in. (25 mm) below return air flange, from inside top of return air opening and through both furnaces. (See Figure 7 as an example.)
11. Drive 1 factory-supplied screw through each hole and tighten until furnaces are secure and foam strips have sealed gap between furnaces.
12. Connect return- and supply-air ducts to furnaces. Seal duct connections to prevent air leakage.
13. Move 115-v junction box JB in RH furnace (as viewed from the upflow position) from left-hand side to right-hand side. Refer to furnace installation instructions for complete details.
14. Go to PROCEDURE 2A for Single Stage Furnaces or PROCEDURE 2B for Two-Stage Furnaces.

B. Upflow/Downflow, Back-to-Back Position

Refer to Figure 3 and Table 2 for appearance and dimensional drawing of twinned furnaces and their connection locations.

1. Select 2 identical heating and airflow furnaces. (See Table 2)
2. Remove outer door and blower access door.
3. Remove bottom closure panels from both furnaces. (See Figure 4)
 - a. Lay furnaces on back or sides.
 - b. Remove 2 screws from bottom front panel.
 - c. Pull front panel forward to remove.
 - d. Remove bottom closure panel and discard.
 - e. Reinstall bottom front panel.
 - f. Stand furnaces upright.
4. Applications

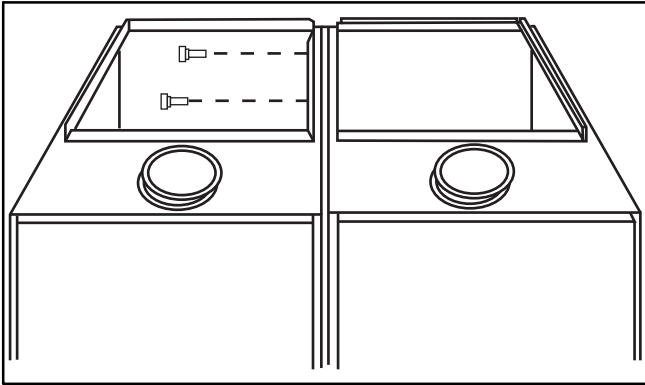

A02232

Figure 6 – Attaching Furnaces Together at Discharge Opening

- a. For upflow applications:
Bottom return air usage is required as part of any upflow return air configuration. If additional return air is to enter 1 side of each furnace, in addition to bottom return air, cut open 1 entire return-air opening in appropriate side of each furnace. (See Figure 2)

WARNING

UNIT DAMAGE AND FIRE HAZARD

Failure to follow this warning could result in unit damage, fire, personal injury or death.

DO NOT use the side of the furnace for return-air duct connections, as limit cycling will occur.

- b. For downflow applications:
Return air can only be connected to bottom opening of furnace. A common return air plenum is required for proper auxiliary limit switch operation. (See Figure 3)
5. Apply 2 factory-supplied foam strips to the back of each furnace. Locate strips equal distance from top and bottom as shown in Figure 5. Trim off excess material.
 6. Determine which side of furnace will be used to route external extension harness. Remove 7/8-in. diameter accessory hole knockouts in blower compartment side selected to attach harness to. (See Figure 3)
 7. Bend or remove the supply flanges as required for upflow or downflow installation. Refer to the furnace installation instructions for complete details.
 8. Position furnaces back-to-back on return-air plenum, supply air plenum or evaporator coil casing. Adjust and shim each furnace to align both furnaces.

NOTE: External extension harness cannot be used on the same side of the furnace that the return air ducts connect to. Locate harness on opposite side of furnace when side return air is used.

9. Drill two 1/8-in. holes, approximately 1 in. (25 mm) below discharge flange, from inside top of discharge opening and through both furnaces. (Similar to Figure 6) Drill two 1/8-in. holes, approximately 1 in. (25 mm) below return air flange, from inside top of return air opening and through both furnaces. (Similar to Figure 7)
10. Drive 1 factory-supplied No. 6 X 3/4-in. LG screw through each hole and tighten until furnaces are secure and foam strips have sealed gap between furnaces.
11. Connect return- and supply-air ducts to furnaces. Seal duct connections to prevent air leakage.

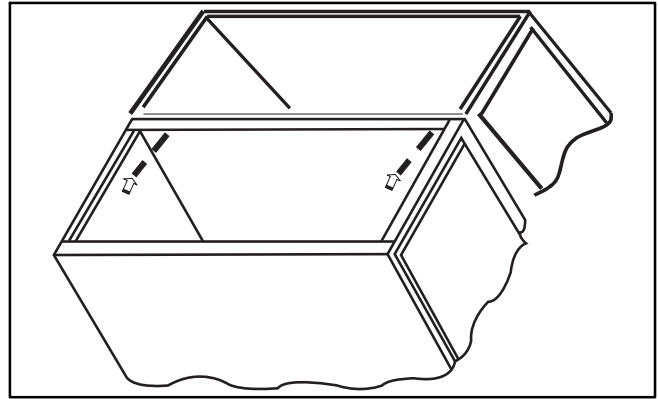

A02219

Figure 7 – Attaching Furnaces Together at Return Air Opening

12. Move 115-v junction box JB in either furnace from left-hand side to right-hand side if required. Refer to furnace installation instructions for complete details.
13. Go to Step 2A for Single Stage Furnaces or Step 2B for Two-Stage Furnaces.

C. Horizontal, Back-to-Back Position

When twinning furnaces in the horizontal position, consideration must be made to the type of building construction. Attic floors should be constructed to support normal live and dead loads of the furnaces and the person(s) servicing them.

Trusses, wood and metal are engineered for specific applications, and may not support the weight of two (2) furnaces suspended from the top chords or the bottom chords of the trusses. Long horizontal spans may flex or sag, resulting in damage to the building. Contact the truss manufacturer for additional design and engineering assistance. Do not suspend furnaces with straps or suspend furnaces from roof decking.

For attic installations on a platform (See Figure 8):

1. Construct a platform from 3/4-in. (76 mm) (nominal plywood), extending out 30 inches (762 mm) from the front of each furnace.
2. Maintain all clearances to combustibles per the furnace Installation, Start-up and Operating Instructions.
3. Follow all additional building codes.
4. Long truss spans may require additional support along the bottom chord of the truss. Consult the truss manufacturer's guidelines for engineering assistance.
5. Long rafter or attic joist spans may require additional support along the bottom of the rafter or joist. Consult local or regional building codes for design and loading requirements.

Figure 8 – Attic Installation of Horizontal Back-to-Back Furnaces

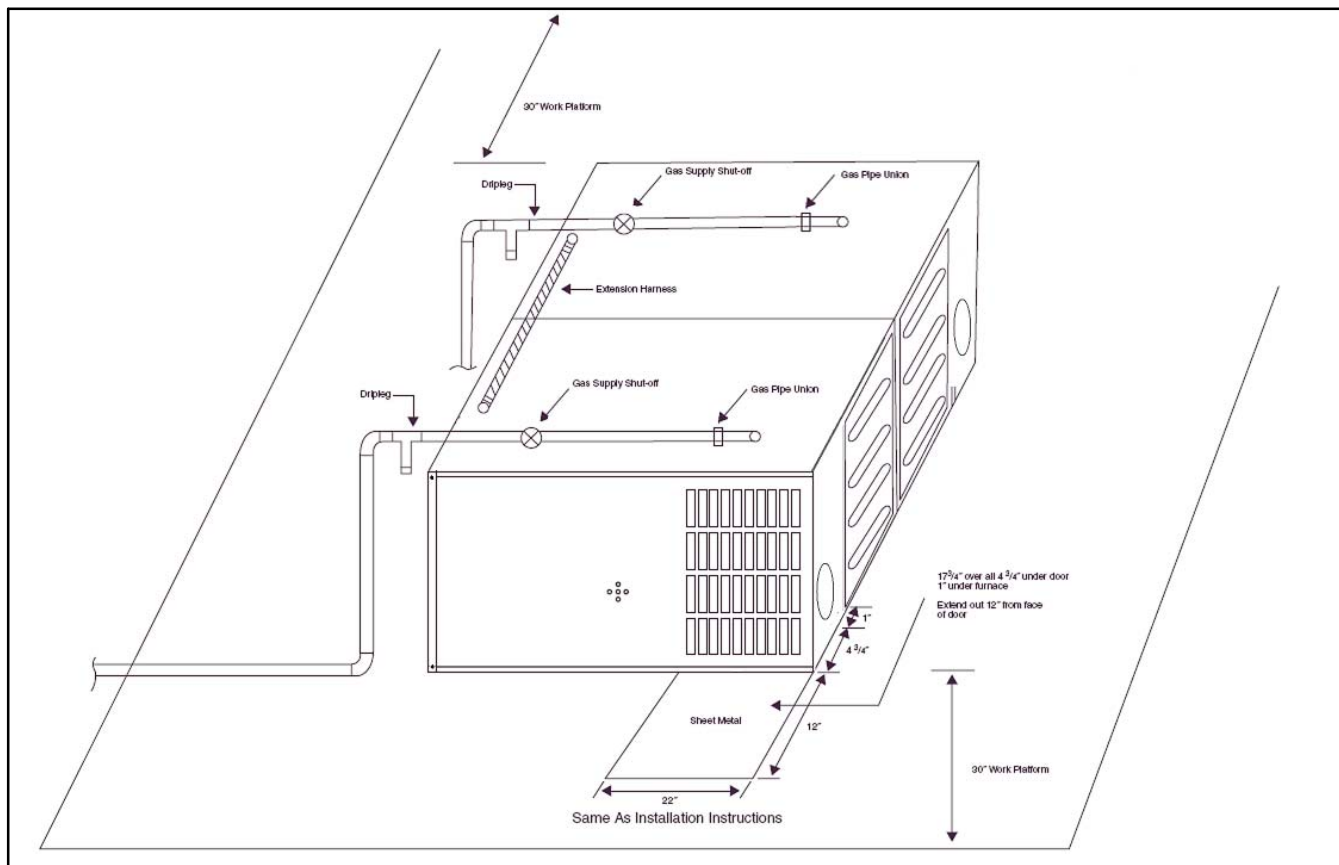

A02241

For suspended installations (See Figure 9) Not recommended for wood trusses unless approved by the truss manufacturer or other approved engineering methods):

1. Furnaces may be suspended using two (2) pieces of 1-1/2-in. x 1-1/4-in x 1/4-in. thick cold rolled angle iron underneath the furnaces and four (4) 3/8-in. diameter threaded rods.
2. Allow for at least 9 inches (229 mm) in front of each door for door removal.
3. Each piece of angle iron must be secured to the bottom of each furnace with at least two (2) #8 x 3/4-in. sheet metal screws.
4. Maintain all clearances to combustibles per the furnace Installation, Start-up and Operating Instructions.
5. Unistrut or similar material may be used, provided that the furnaces do not sag in the middle or bend or twist at the support ends. The support material must be secured to the bottom of each furnace in a manner similar to securing angle iron to the furnace.

Refer to Figure 3 and Table 2 for appearance and dimensional drawing of twinned furnaces and their connection locations.

1. Select 2 identical heating and airflow furnaces. (See Table 2)
2. Remove outer door and blower access door.
3. Remove bottom closure panels from both furnaces. (See Figure 4)
 - a. Lay furnaces on back or sides.
 - b. Remove 2 screws from bottom front panel.

c. Pull front panel forward to remove.

d. Remove bottom closure panel and set aside for possible use as roll-out protection.

e. Reinstall bottom front panel.

f. Stand furnaces upright.

4. For All Horizontal applications:

Return air can only be connected to bottom opening of furnace. (See Figure 2) A common return air plenum is required for proper auxiliary limit switch operation.

⚠ WARNING

UNIT DAMAGE AND FIRE HAZARD

Failure to follow this warning could result in unit damage, fire, personal injury or death.

DO NOT use the side or back of the furnace for return-air duct connections in the horizontal position, as limit cycling will occur.

5. Apply 2 factory-supplied foam strips to the back of each furnace. Locate strips equal distance from top and bottom as shown in Figure 5. Trim off excess material.

6. Determine which side of furnace will be used to route external extension harness. Remove 7/8-in. diameter accessory hole knockouts in blower compartment side selected to attach harness to. (See Figure 3)

Figure 9 – Suspended Installation for Horizontal Furnaces Back-to-Back

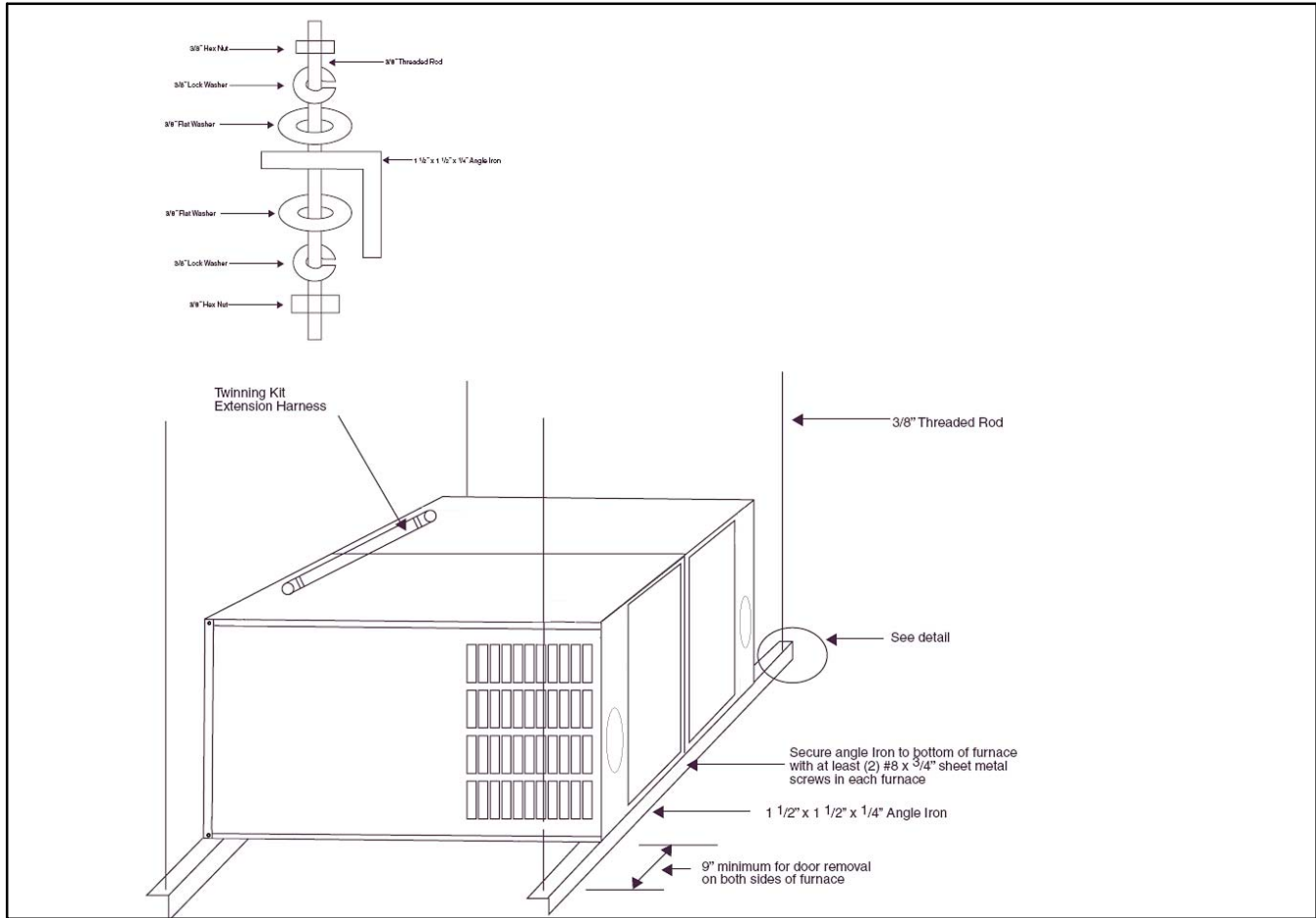

7. Position furnaces back-to-back on attic platform or suspended supports. Adjust and shim each furnace to align both furnaces. Follow all clearance to combustible material.
 8. If furnaces are installed closer than 12 inches above a deck made from combustible material, provide roll-out protection as shown in the furnace installation instructions. The bottom closure pan may be used for this purpose.
- NOTE:** DO NOT lay furnace down flat on the side that external extension harness is installed. Raise furnace up a minimum of 1-1/2 inches (38 mm) above deck so harness does not rub on casing or deck.
9. Drill two 1/8-in. holes, approximately 1 in. (25 mm) below discharge flange, from inside top of discharge opening and through both furnaces. (See Figure 6) Drill two 1/8-in. holes, approximately 1 in. (25 mm) below return air flange, from inside top of return air opening and through both furnaces. (Use Figure 6 as an example).
 10. Drive 1 factory-supplied No. 6 X 3/4-in. LG screw through each hole and tighten until furnaces are secure and foam strips have sealed gap between furnaces.
 11. Connect return- and supply-air ducts to furnaces. Seal duct connections to prevent air leakage.
 12. Move 115-v junction box JB in either furnace from left-hand side to right-hand side if required. Refer to furnace installation instructions for complete details.
 13. Go to PROCEDURE 2A for Single Stage Furnaces or PROCEDURE 2B for Two-Stage Furnaces.

D. Horizontal, Stacked Together

When twinning furnaces in the horizontal position, consideration must be made to the type of building construction. Attic floors should be constructed to support normal live and dead loads of the furnaces and the person(s) servicing them.

Trusses, wood and metal are engineered for specific applications, and may not support the weight of two (2) furnaces suspended from the top chords or the bottom chords of the trusses. Long horizontal spans may flex or sag, resulting in damage to the building. Contact the truss manufacturer for additional design and engineering assistance. Do not suspend furnaces with straps or suspend furnaces from roof decking.

For attic installations on a platform, see Figure 10:

1. Construct a platform from 3/4-in. (nominal plywood), extending out 30 inches (762 mm) from the front of each furnace.
2. Maintain all clearances to combustibles per the furnace Installation, Start-up and Operating Instructions.
3. Follow all additional building codes.
4. Long truss spans may require additional support along the bottom chord of the truss. Consult the truss manufacturer's guidelines for engineering assistance.
5. Long rafter or attic joist spans may require additional support along the bottom of the rafter or joist. Consult local or regional building codes for design and loading requirements.

Figure 10 – Attic Installation of Horizontal Furnace Stacked Together

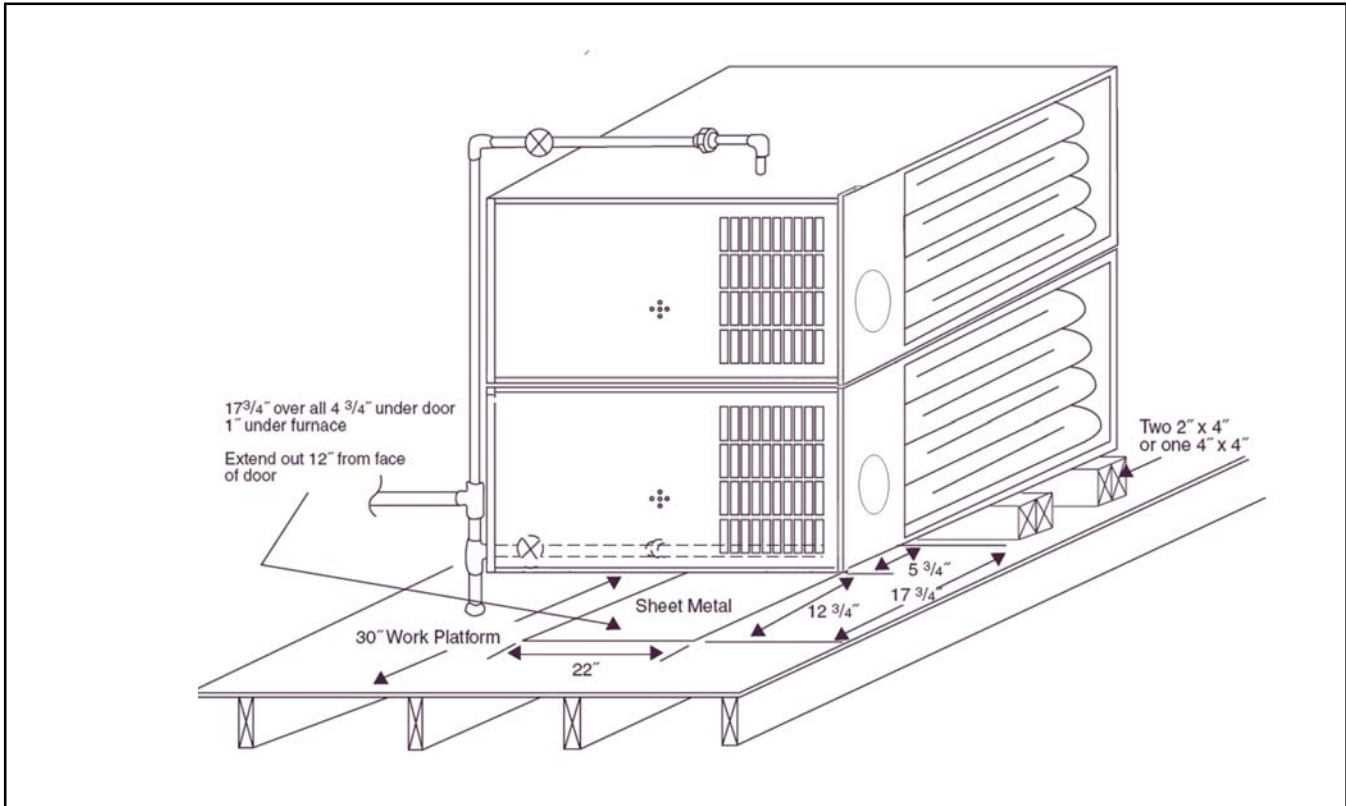
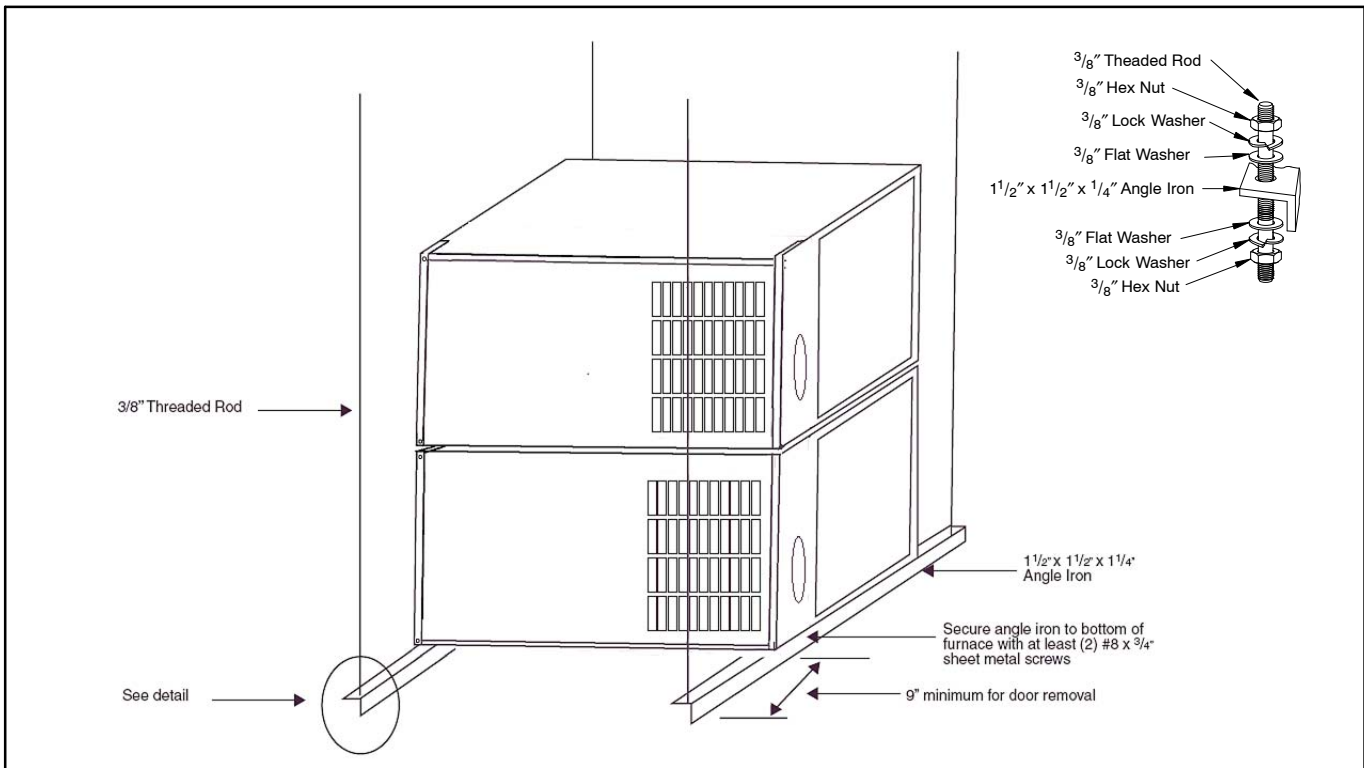

Figure 11 – Suspended Installation for Horizontal Furnaces Stacked Together



For suspended installations, see Figure 11. Not recommended for wood trusses unless approved by the truss manufacturer or other approved engineering methods):

1. Furnaces may be suspended using two (2) pieces of 1-1/2-in. x 1-1/2-in. x 1/4-in. thick cold rolled angle iron underneath the furnaces and four (4) 3/8-in. diameter threaded rods.

2. Allow for at least 9 inches (229 mm) in front of each door for door removal.
3. Each piece of angle iron must be secured to the bottom of each furnace with at least two (2) #8 x 3/4-in. sheet metal screws.
4. Maintain all clearances to combustibles per the furnace Installation, Start-up and Operating Instructions.

5. Unistrut or similar material may be used, provided that the furnaces do not sag in the middle or bend or twist at the support ends. The support material must be secured to the bottom of each furnace in a manner similar to securing angle iron to the furnace.

Refer to Figure 3 and Table 2 for appearance and dimensional drawing of twinned furnaces and their connection locations.

1. Select 2 identical heating and airflow furnaces. (See Table 2)
2. Remove outer door and blower access door.
3. Remove bottom closure panels from both furnaces. (See Figure 4)
 - a. Lay furnaces on back or sides.
 - b. Remove 2 screws from bottom front panel.
 - c. Pull front panel forward to remove.
 - d. Remove bottom closure panel and set aside for possible use as roll-out protection.
 - e. Reinstall bottom front panel.
 - f. Stand furnaces upright.
4. For all horizontal applications: Return air can only be connected to bottom opening of furnace.
5. Apply 2 factory-supplied foam strips to mating side of each furnace. Locate strips equal distance from top and bottom as shown in Figure 5.
6. Remove 7/8-in. diameter accessory hole knockouts in blower compartment from mating sides of furnaces. (See Figure 3)
7. Insert a plastic snap bushing through the 7/8-in. K.O. from the outside of the casing.
8. Position furnaces on top of each other on platform or suspended supports. Adjust and shim each furnace to align 7/8-in. diameter holes in both furnaces.
9. Drill two 1/8-in. holes, approximately 1 in. (25 mm) below discharge flange, from inside top of discharge opening and through both furnaces. (See Figure 6) Drill two 1/8-in. holes, approximately 1 in. (25 mm) above return air opening flange, from inside blower compartment and through both furnaces. (See Figure 7)
10. Drive 1 factory-supplied screw through each hole and tighten until furnaces are secure and foam strips have sealed gap between furnaces.
11. Connect return- and supply-air ducts to furnaces. Seal duct connections to prevent air leakage.
12. Move 115-v junction box JB in RH furnace (as viewed from the upflow position) from left-hand side to right-hand side. Refer to furnace installation instructions for complete details.
13. Go to PROCEDURE 2A for Single Stage Furnaces or PROCEDURE 2B for Two-Stage Furnaces.

PROCEDURE 2 — CONNECT ELECTRICAL COMPONENTS—HEATING

A. All Single-Stage Models N8MSN & N8MSL Multipoise Single-Speed Non-Condensing HSI Furnaces

⚠ WARNING

FIRE HAZARD

Failure to follow this warning could result in fire, personal injury or death.

Make no connections between the R 24-vac connector in 1 furnace and the R 24-vac connector in other furnace.

See Electrostatic Discharge Precaution Section.

The twinning kit can be used for single-stage or two-stage heating operation. There are 3 harness assemblies included in this kit. If the furnaces are side-by-side, only 2 harness assemblies are required. If the furnaces are installed back-to-back, all 3 harness assemblies included in the kit must be used.

1. Remove outer doors and blower access doors from both furnaces.
2. If furnaces are installed back-to-back in any orientation, the external Extension Harness must be used. The harness consists of:
 - a. 54-1/2 inches (1384 mm) of 1/2-in. flexible steel conduit
 - b. (2) 90° conduit connectors
 - c. (1) 4 wire polarized wiring harness
 - d. (1) 2 wire polarized wiring harness
3. Install the Extension Harness as follows:
 - a. Remove lock nuts from the end of each conduit connector.
 - b. Route the end of the harness, labeled "twinning kit harness," that mates to the TRK relay harness from the outside of the furnace through the 7/8-in. knock-out in the casing to the blower compartment.
 - c. Route the end of the harness that mates to the 4-wire harness through the outside of the furnace through the 7/8-in. knockout in the casing to the blower compartment.
 - d. Install the lock nuts on the 90° conduit connectors.
 - e. Install 2 kit-supplied straps approximately 18 inches (457 mm) from each end of harness.

Single-Stage Heat with Single-Stage Gas-Heat Thermostat (Field-Supplied)

NOTE: This application allows both furnaces to operate as 1 furnace in gas heat mode as determined by single-stage thermostat operation. Both furnaces operate in heating mode simultaneously. See furnace Installation, Start-Up, and Operating Instructions for further details on this heating mode.

1. Install harness labeled "Main Furnace" with TKR on L/H Furnace:
The Main Harness includes the TKR relay and Auxiliary Limit switch on the harness. The harness is also tagged "Main Furnace" near the ends of the plug connector.
 - a. Secure relay of TKR harness assembly to LH furnace blower housing using 2 factory-supplied screws. (See Figure 12)

NOTE: See Figure 15 for Single Stage furnace Twinning Kit wiring diagram.

- b. Connect TKR white wire labeled W from TKR to LH furnace control thermostat connection W.
- c. Connect TKR black wire labeled C from TKR to LH furnace control thermostat connection C.
- d. Connect yellow wire labeled TEST to LH furnace control TEST/TWIN terminal.
- e. If Extension Harness was used, connect 4-wire harness to Extension Harness.

NOTE: If Extension Harness will not plug in to L/H and R/H furnaces, extension harness is installed backward. Remove extension harness and re-install in correct orientation.

Figure 12 – TKR Relay Secured with Factory–Supplied Screws

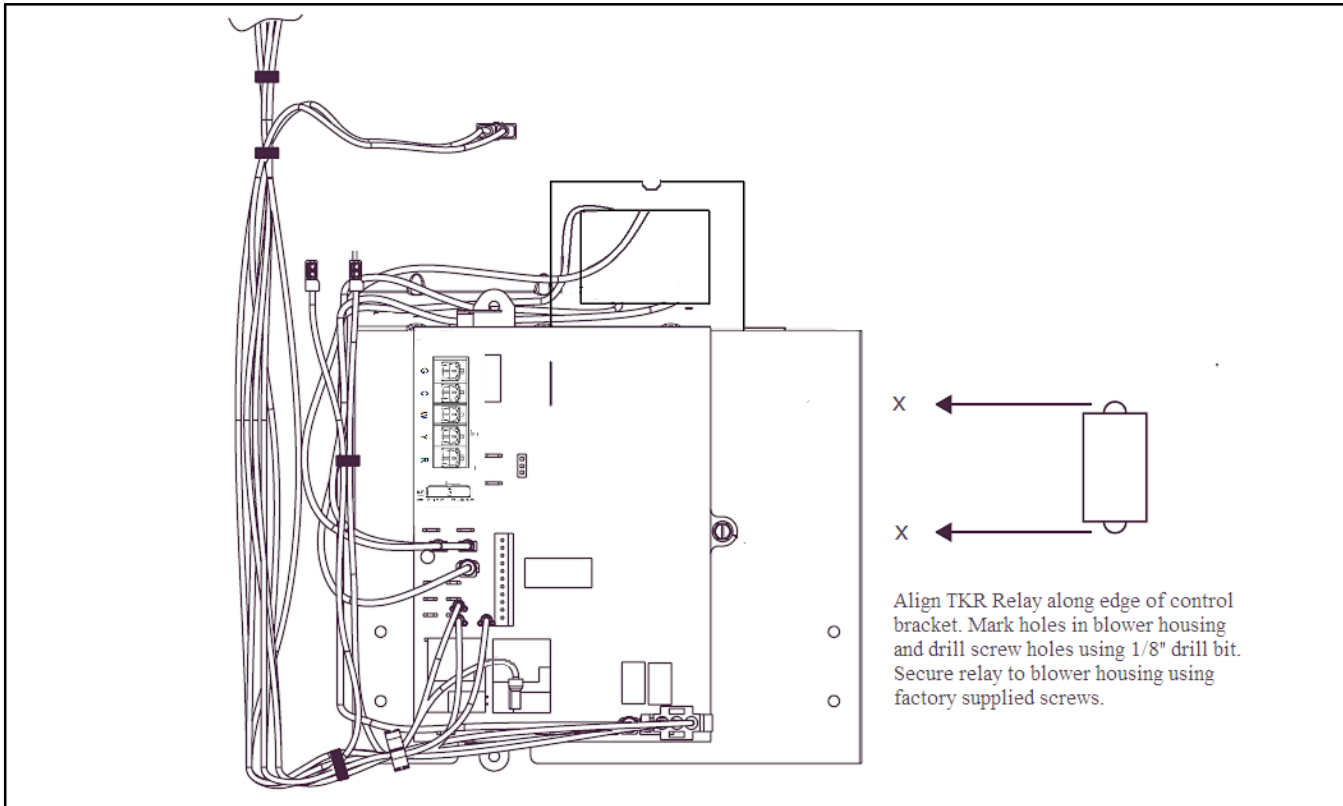

2. Install Auxiliary Limit Switch (ALS–M) on L/H furnace:
 - a. Drill 1/8–in. hole in blower housing 12 in. (305 mm) below blower shelf. (See Figure 13)
 - b. Position ALS–M so reset button faces front of furnace.
 - c. Secure bracket to blower housing using a factory–supplied screw.
 - d. Disconnect red transformer wire from LH furnace control 24 VAC connection.
 - e. Connect red transformer wire connector to ALS–M wire connector PLC labeled TRAN.
 - f. Connect orange ALS–M wire connector labeled SEC 1 to LH furnace control 24 VAC terminal.
 - g. If Extension Harness was used, connect 2–wire harness to Extension Harness
3. Install Secondary 4–wire harness on R/H furnace:

The Secondary Harness includes the Auxiliary Door Switch and Auxiliary Limit Switch. The harness is also tagged “Secondary Furnace” near the plug ends of the harness.

 - a. Connect red wire labeled R–Secondary to RH furnace control thermostat connection R.
 - b. Connect white wire labeled W–Secondary to RH furnace control thermostat connection W.
 - c. Connect black wire labeled C–Secondary to RH furnace control thermostat connection C.
 - d. Connect yellow wire labeled TEST SECONDARY to RH furnace control TEST/TWIN terminal.
 - e. If the furnaces are side–by–side, route loose ends of 4–wire harness from Secondary furnace to Main furnace through snap bushings previously installed between furnaces. (See Figure 4)
 - f. Connect Secondary 4–wire harness into 4–wire Main harness.
 - g. If Extension Harness was installed, connect 4–wire Secondary Harness to the Extension Harness.
4. Install Auxiliary Limit Switch, ALS–S on Secondary furnace:
 - a. Drill 1/8–in. hole in blower housing 12 in. (305 mm) below blower shelf. (See Figure 13)
 - b. Position ALS–S with terminals facing front of furnace.
 - c. Secure bracket to blower housing using factory–supplied screw.

5. Install Auxiliary Blower Door Interlock Switch, (See Figure 13) ILK–1 on Secondary furnace:

NOTE: This kit contains two auxiliary blower door switch brackets. Assure that switch bracket used matches bracket used for factory installed blower door switch.

 - a. Measure along the left edge of the furnace casing, 6 inches (152 mm) down from blower shelf.
 - b. Drill a 3/16–in. clearance hole through front edge of blower door support.
 - c. Insert blower door switch mounting tab behind front edge of blower door support.
 - d. Secure auxiliary door switch ILK–1 using factory–supplied screw.
 - e. Connect 2–Wire Secondary Harness to 2–wire Main Harness that was routed through furnace casings.
 - f. If extension harness was installed, 2–wire Secondary Harness from Secondary to Main Extension Harness.

NOTE: If Extension Harness will not plug in to L/H and R/H furnaces, extension harness is installed backward. Remove extension harness and re–install in correct orientation.

6. Select identical blower motor speed taps at control center connectors in both furnaces.

⚠ CAUTION

UNIT DAMAGE HAZARD

Failure to follow this caution may result equipment damage.

Failure to select identical blower speed taps in both furnaces can result in overheating of furnace components and possible loss of furnace operation and damage to the furnaces.

7. Dress wires to ensure they do not contact sharp or moving parts nor interfere with blower operation, removal of filters, or operation of switches.
8. Make all thermostat connections to LH furnace only. See Figure 15.

Figure 13 – Auxiliary Door Switch

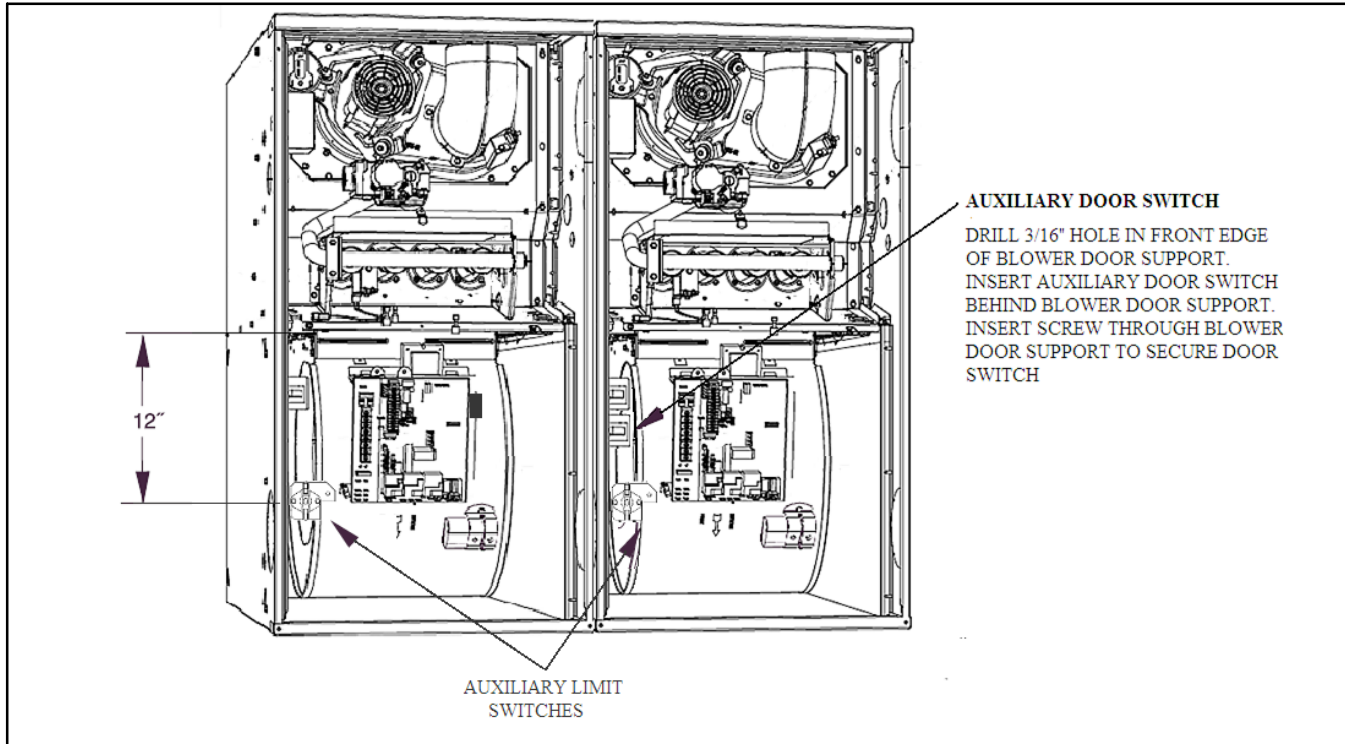

AUXILIARY DOOR SWITCH
 DRILL 3/16" HOLE IN FRONT EDGE
 OF BLOWER DOOR SUPPORT.
 INSERT AUXILIARY DOOR SWITCH
 BEHIND BLOWER DOOR SUPPORT.
 INSERT SCREW THROUGH BLOWER
 DOOR SUPPORT TO SECURE DOOR
 SWITCH

**AUXILIARY LIMIT
 SWITCHES**

Two-Stage Heat with Two-stage Gas-Heat Thermostat (Field Supplied)

NOTE: ALL thermostat connections are to be made to LH furnace control ONLY. (See Figure 16)

NOTE: This application allows only the LH furnace to operate for first-stage heat mode or both furnaces to operate for second-stage heat mode as determined by a two-stage thermostat. See furnace Installation, Start-Up, and Operating Instructions for further details on this heating mode.

To operate furnaces in two-stage heating mode when a two-stage thermostat controls the staging, install twinning kit as described in Single-Stage Heat with Single-Stage Gas Heat Thermostat, then modify TKR wiring as follows:

- a. Disconnect TKR white wire labeled W from the LH furnace control thermostat connection W.
- b. Cut off terminal of TKR white wire labeled W and strip 1/4 in. (6 mm).
- c. Connect two-stage thermostat W2 connection to TKR white wire labeled W.

back-to-back, all 3 harness assemblies included in the kit must be used.

⚠ WARNING

FIRE HAZARD

Failure to follow this warning could result in fire, personal injury or death.

Make no connections between the R 24-vac connector in 1 furnace and the R 24-vac connector in other furnace.

⚠ CAUTION

PERSONAL INJURY HAZARD

Failure to follow this caution could result in intermittent furnace operation and unit damage.

Supply-air temperature will be uneven left-to-right when only main system is operating.

NOTE: ALL other two-stage thermostat connections are to be made to LH furnace control ONLY. (See Figure 16)

B. All Two-Stage Models: F8MTL & G8MTL Two-Speed Non-Condensing HSI Furnaces with PSC Motors

See Electrostatic Discharge Precaution Section.

The twinning kit can be used for single-stage or two-stage heating operation. There are 3 harness assemblies included in this kit. If the furnaces are side-by-side, only 2 harness assemblies are required. If the furnaces are installed

1. Remove outer doors and blower access doors from both furnaces.
2. If furnaces are installed back-to-back in any orientation, the external Extension Harness must be used. The harness consists of:
 - a. 54-1/2-in. of 1/2-in. flexible steel conduit
 - b. (2) 90° conduit connectors
 - c. (2) 4 wire polarized wiring harness
 - d. (2) 2 wire polarized wiring harness
3. Install the Extension Harness as follows:
 - a. Remove lock nuts from the end of each conduit connector.
 - b. Route the end of the harness labeled "Twinning Kit Harness" that mates to the TKR relay harness from the outside of the furnace through the 7/8-in. knock-out in the casing to the blower compartment.
 - c. Route the end of the harness that mates to the 4-wire harness through the outside of the furnace through the 7/8-in. knockout in the casing to the blower compartment.
 - d. Install the lock nuts on the 90° conduit connectors.

Two-Stage Heat with Single-Stage Gas-Heat Thermostat (Field Supplied) (See Figure 17).

NOTE: This application allows both furnaces to operate as 1 furnace in gas heat mode as determined by single-stage thermostat operation. Both furnaces operate in heating mode simultaneously. See furnace Installation, Start-Up, and Operating Instructions for further details on this heating mode.

1. Install harness labeled "Main Furnace" with TKR on L/H Furnace: The Main Harness includes the TKR relay and Auxiliary Limit switch on the harness. The harness is also tagged "Main Furnace" near the ends of the plug connector.
 - a. Secure relay of TKR harness assembly to LH furnace blower housing using 2 factory-supplied screws. Two new screw holes will have to be drilled using a 1/8-inch drill bit. See Figure 12 for location of holes to be drilled.
 - b. Connect TKR white wire labeled W from TKR to LH furnace control thermostat connection W/W1.
 - c. Connect TKR black wire labeled C from TKR to LH furnace control thermostat connection C.
 - d. Connect yellow wire labeled TEST to LH furnace control TEST/TWIN terminal.
 - e. If Extension Harness was used, connect 4-wire harness to Extension Harness.
 - f. Turn TT set-up switch on L/H control board to "OFF." (See Figure 14)
 - g. Turn TT set-up switch on R/H control board to "ON."

NOTE: If Extension Harness will not plug in to L/H and R/H furnaces, extension harness is installed backward. Remove extension harness and re-install in correct orientation.

2. Install Auxiliary Limit Switch (ALS-M) on L/H furnace:
 - a. Drill 1/8-in. hole in blower housing 12 in. (305 mm) below blower shelf. (See Figure 13)
 - b. Position ALS-M so reset button faces front of furnace.
 - c. Secure bracket to blower housing using a factory-supplied screw.
 - d. Disconnect red transformer wire from LH furnace control 24 VAC connection.
 - e. Connect red transformer wire connector to ALS-M wire connector PLC labeled TRAN.
 - f. Connect ALS-M orange wire connector labeled SEC 1 to LH furnace control 24 VAC terminal.
- g. If Extension Harness was used, connect 2-wire harness to Extension Harness

3. Install Secondary 4-wire harness on R/H furnace:

The Secondary Harness includes the Auxiliary Door Switch and Auxiliary Limit Switch. The harness is also tagged "Secondary Furnace" near the plug ends of the harness.

- a. Connect red wire labeled R-Secondary to RH furnace control thermostat connection R.
- b. Connect white wire labeled W-Secondary to RH furnace control thermostat connection W/W1.
- c. Connect black wire labeled C-Secondary to RH furnace control thermostat connection C.
- d. Connect yellow wire labeled TEST SECONDARY to RH furnace control TEST/TWIN terminal.
- e. If the furnaces are side-by-side, route loose ends of 4-wire harness from Secondary furnace to Main furnace through snap bushings previously installed between furnaces.
- f. Connect Secondary 4-wire harness into 4-wire Main harness.

- g. If Extension Harness was installed, connect 4-wire Secondary Harness to the Extension Harness.

4. Install Auxiliary Limit Switch, ALS-S on Secondary furnace:
 - a. Drill 1/8-in. hole in blower housing 12 in. (305 mm) below blower shelf. (See Figure 13)
 - b. Position ALS-S with terminals facing front of furnace.
 - c. Secure bracket to blower housing using factory-supplied screw.
5. Install Auxiliary Blower Door Interlock Switch, ILK-1 on Secondary furnace:

NOTE: This kit contains two auxiliary blower door switch brackets. Assure that switch bracket used matches bracket used for factory installed blower door switch.

- a. Measure along the left edge of the furnace casing, 6 inches (152 mm) down from blower shelf.
- b. Drill a 3/16-in. clearance hole through front of blower door support.
- c. Insert blower door switch mounting tab behind blower door support
- d. Secure auxiliary door switch ILK-1 using factory-supplied shallow head screw.
- e. Connect 2-Wire Secondary Harness to 2-wire Main Harness that was routed from Secondary to Main furnace casings.
- f. If extension harness was installed, 2-wire Secondary Harness to Extension Harness.

NOTE: If Extension Harness will not plug in to L/H and R/H furnaces, extension harness is installed backward. Remove extension harness and re-install in correct orientation.

6. Select identical blower motor speed taps at control motor connectors in both furnaces.



CAUTION

UNIT DAMAGE HAZARD

Failure to follow this caution may result in unit damage.

Failure to select identical blower speed taps in both furnaces can result in overheating of furnace components and possible loss of furnace operation and damage to the furnaces

7. Dress wires to ensure they do not contact sharp or moving parts nor interfere with blower operation, removal of filters, or operation of switches.

8. Make all thermostat connections to LH furnace only.

Two-Stage Heat with Two-stage Gas-Heat Thermostat (Field Supplied)

NOTE: ALL thermostat connections are to be made to LH furnace control ONLY. (See Figure 17)

NOTE: This application allows both furnaces to operate in low heat for first-stage heat mode or both furnaces to operate in high heat for second-stage heat mode as determined by a two-stage thermostat. See furnace Installation, Start-Up, and Operating Instructions for further details on this heating mode.

To operate furnaces in two-stage heating mode when a two-stage thermostat controls the staging, install twinning kit as described in the two-stage heat with single-stage gas heat thermostat:

- a. Turn TT set-up switch on L/H control board to "ON."
- b. Turn TT set-up switch on R/H control board to "ON."

NOTE: ALL other two-stage thermostat connections are to be made to LH furnace control ONLY. (See Figure 17)

Figure 14 – TT Switch Settings

		Thermostat Type	Main (LH) TT Switch 1	Secondary (RH) TT Switch 1
TT		One Stage Thermostat	OFF	ON
OFF DLY				
		Two Stage Thermostat	ON	ON

PROCEDURE 3 — CONNECT ELECTRICAL COMPONENTS—COOLING

WARNING

ELECTRICAL OPERATION HAZARD

Failure to follow this warning could result in fire, personal injury or death.

Failure to follow warning could result in fire, personal injury or death. Make no connections between the R 24-vac connector in one furnace and the R 24-vac connector in other furnace.

When installing twinned outdoor units with twinned gas furnaces, it is necessary to use a field-supplied 24-vac pilot-duty relay and a field-supplied 24/115-vac transformer as shown in Figure 15, Figure 16, or Figure 17 to prevent overloading furnace 24/115-vac transformer.

PROCEDURE 4 — VENTING

Refer to Installation, Start-Up, and Operating Instructions supplied with each furnace for venting information.

CAUTION

UNIT DAMAGE HAZARD

Failure to follow this caution may result in unit damage

When common-venting twinned, Category I (negative-pressure venting), non-condensing furnaces, excessive condensate may occur as a result of oversized vent systems. Dedicated vents and/or proper vent sizing, per the current edition of the National Fuel Gas Code, will reduce the potential for condensation.

PROCEDURE 5 — GAS SUPPLY PIPING

NOTE: All gas connections must be made through exposed outer side of each furnace. Do not common connect any connection other than supply and return-air ducts.

Furnaces are recommended to be provided with a single shutoff valve. However, individual shutoff valves may be required by local codes or jurisdictions. Refer to Installation, Start-Up, and Operating Instructions provided with each furnace for additional gas supply information.

PROCEDURE 6 — ELECTRICAL SUPPLY CONNECTIONS

NOTE: All electrical power connections must be made through exposed outer side of each furnace. Do not common connect any connection other than supply- and return-air ducts.

- Each furnace shall be connected to its own 115-vac power supply. The twinning kit installation interconnects the furnaces, allowing them to operate as a single furnace. The L1 (black) connection to each furnace must be connected to circuit breakers connected to the same service panel 115-vac phase leg.

On single-phase (residential) systems, each furnace circuit breaker should be located directly across from each other in service panel, or each furnace circuit breaker should be located on the same side of service panel, but must skip 1 space to be connected to the same leg of the 1-phase power supply.

On 3-phase (commercial) systems, each furnace circuit breaker should be located directly across from each other in service panel, or each furnace circuit breaker should be located on the same side of service panel, but must skip 2 spaces to be connected to the same leg of the 3-phase power supply.

The proper 115-vac phasing of furnace connections permits 24-vac transformer phasing as described below.

- Phasing of the connected 24-vac transformer secondary circuits can be determined with the LED status of both furnaces. See furnace Installation, Start-Up, and Operating Instructions and status code labels on blower doors. The furnaces' transformers' black leads should be connected to XFMR connectors and white leads to NEUTRAL connectors on controls. If 1 or both LEDs are rapidly flashing, disconnect lead at TEST/TWIN terminal of LH furnace and observe LED at each furnace.
- To verify that the furnaces are in phase, check from Main furnace L1 to Secondary furnace L1 with a voltmeter. If the furnaces are in phase, the voltage between both furnaces will be ZERO.

IF:

- Both LEDs are flashing a heart beat. System phasing is okay.
 - One or both LEDs are flashing status code 10:
 - Line voltage polarity is reversed
 - Reverse 24 VAC and COM in furnace flashing status code 10.
 - One LED is off, 1 LED is flashing a heart beat.
 - The 24 VAC circuit is inoperative on furnace with LED light off.
 - Check transformers, auxiliary limits, and door switches in both furnaces and correct problem.
 - One or both LEDs are dim or flickering. Furnaces are on different phase legs. Disconnect TWIN/TEST lead. If both LEDs are flashing a heart beat when TWIN/TEST is disconnected, furnace line voltage power supply is out of phase.
- Reconnect lead at TWIN/TEST terminal of LH furnace and observe LED at each furnace. The LEDs will flash a heart beat for proper phasing.

PROCEDURE 7 — START-UP AND ADJUSTMENT

Refer to Installation, Start-Up, and Operating Instructions supplied with furnaces for detailed information.

1. Shut off all power and gas to both furnaces.
2. Position blower off delay switches on controls in BOTH furnaces to SAME desired gas heat blower off delay. (See Figure 18 and Figure 19) See furnace Installation, Start-Up, and Operating Instructions for further details.
3. Attach twinning connection wiring label above the existing furnace wiring label on the inside of the L/H furnace blower access door. Use the following labels for the following applications:

Single Stage furnaces with single-stage thermostat, 337070-101 Single Stage furnaces with two-stage thermostat, 337069-101 Two Stage furnaces with single-stage or two-stage thermostat, 337068-101

4. Attach twinning reference label 327956-101 on outside of blower access door of RH furnace blower door.
5. Turn on power and gas to both furnaces.
6. Reinstall blower access doors on both furnaces.

7. Operate furnaces through 2 cycles in each mode to confirm correct operation by operating only thermostat.
 - a. Single-stage gas heating thermostat R-to-W operates both furnaces gas heat mode. First stage of a two-stage thermostat causes LH furnace to operate in gas-heat mode. Second stage of a two-stage thermostat causes both furnaces to operate in gas heat mode.
 - b. Single stage thermostat operates first or second stage of a two stage furnace, based on the furnace control board algorithm. two-stage heating thermostat R-to-W/W1 will operate both furnaces in low heat mode. Thermostat R to W/W1 and -W2 causes both furnaces to operate in high gas-heat mode.
 - c. Thermostat R-to-G for continuous fan or low-cooling blower.
 - d. Cooling thermostat R-to-G-and-Y for single-speed cooling blower.
8. Reinstall control doors on both furnaces.
9. Instruct user in operation of furnace and thermostat.

Figure 15 – Single-Stage Furnace and A/C Single-Stage Thermostat

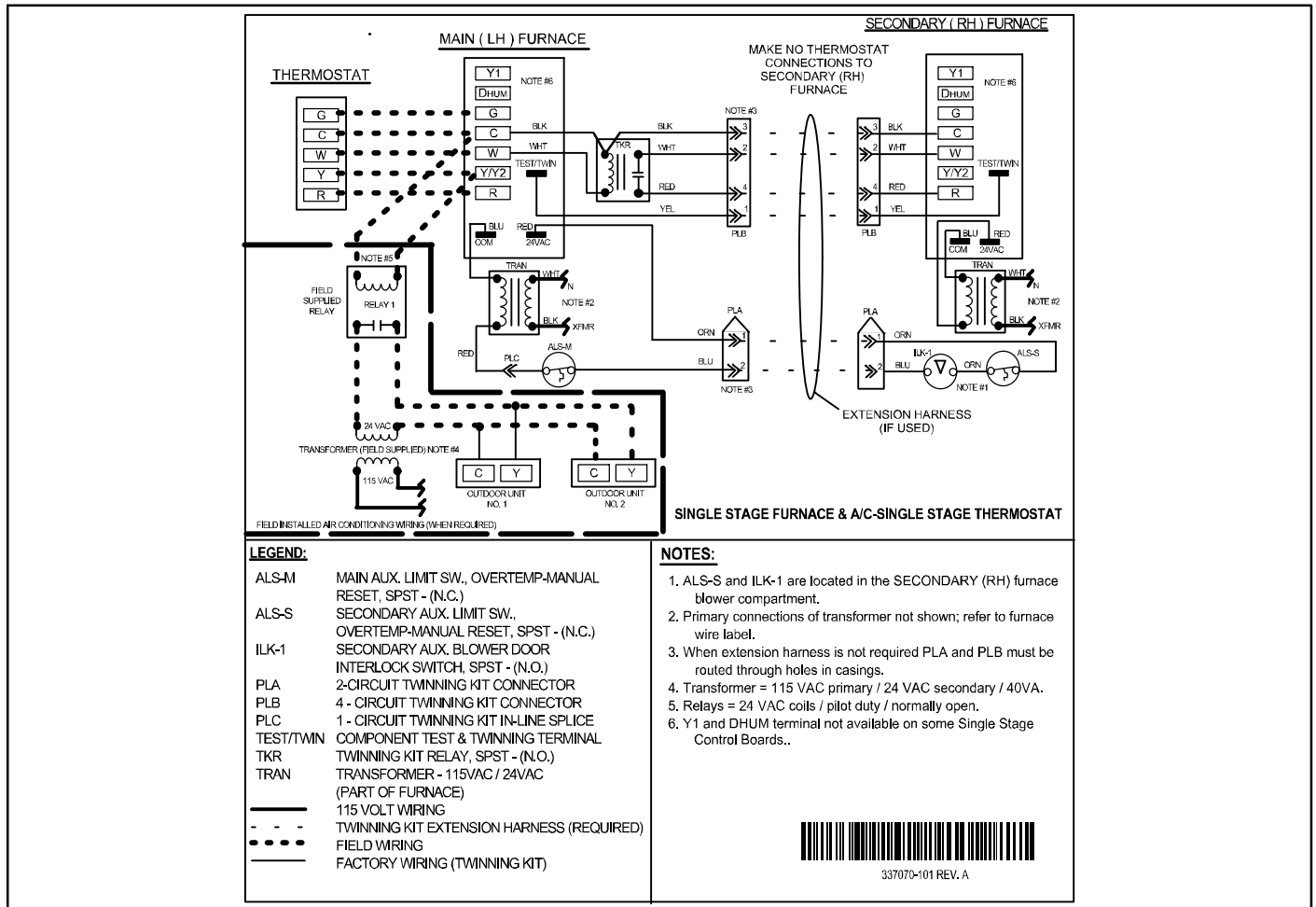

Figure 16 – Single-Stage Furnace and A/C Two-Stage Thermostat

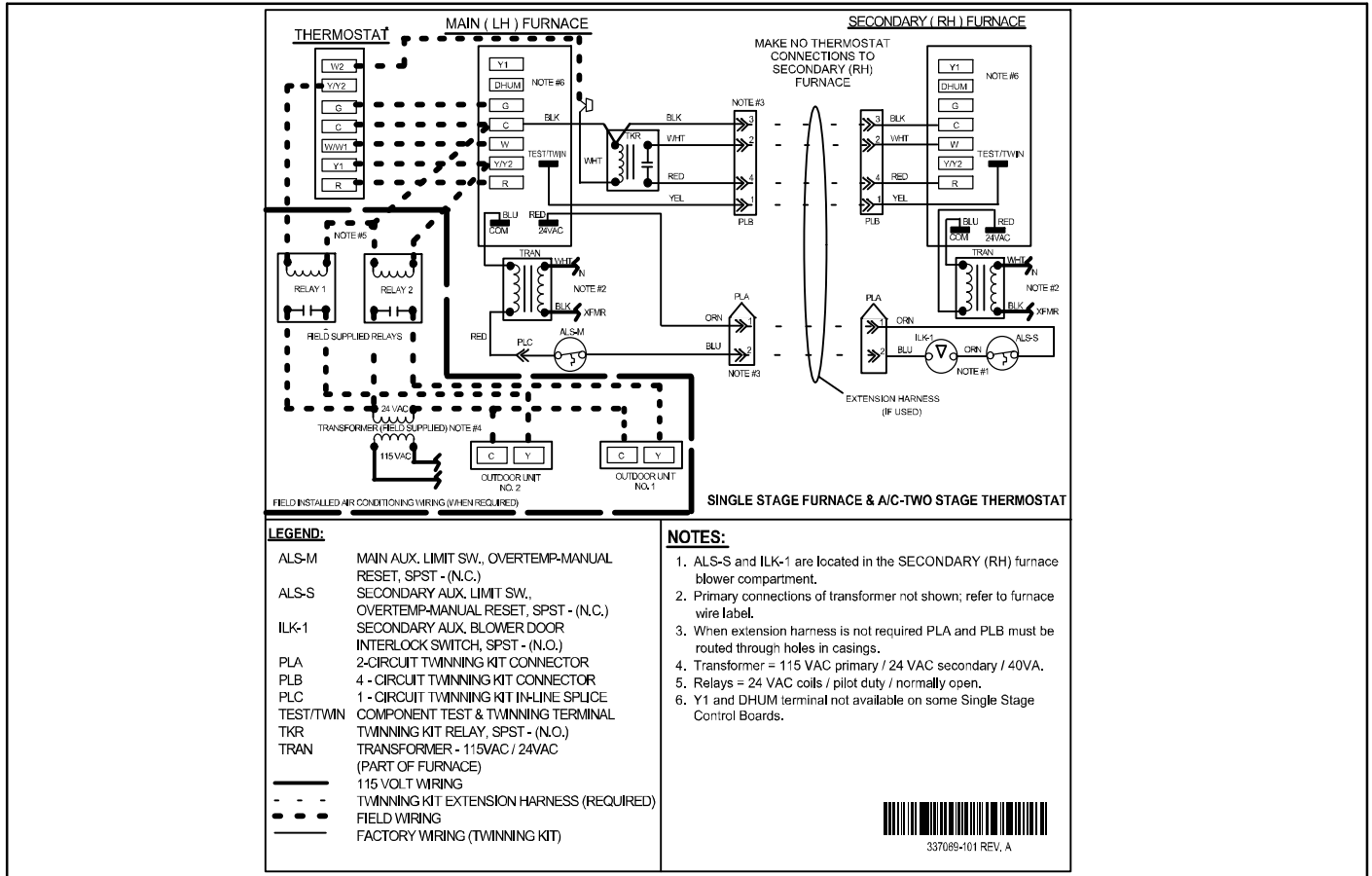

Figure 17 – Two-Stage Furnaces and 1-Stage A/C Unit – One or Two-Stage Thermostat

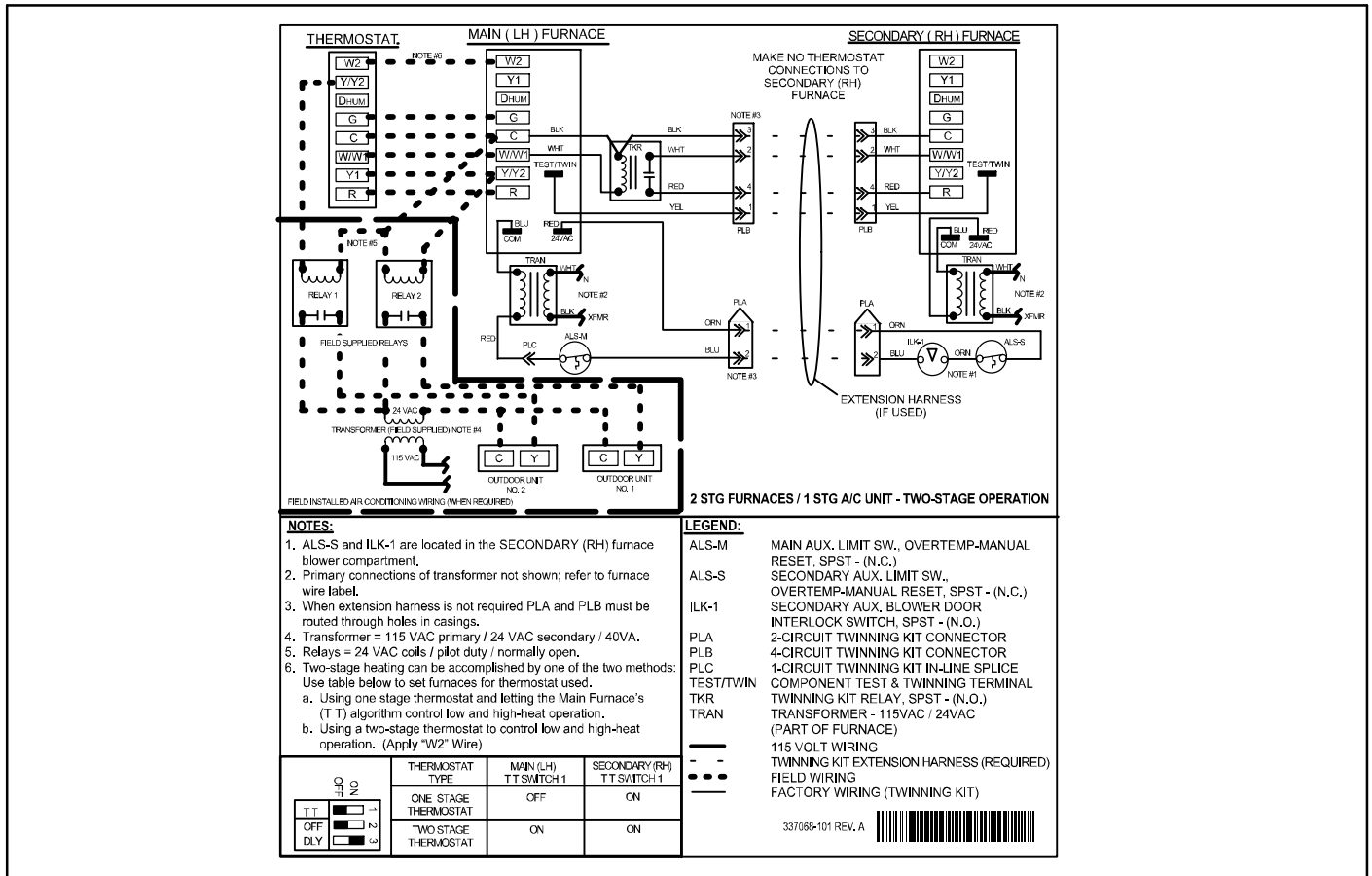

Figure 18 – Single-Stage Furnace Control

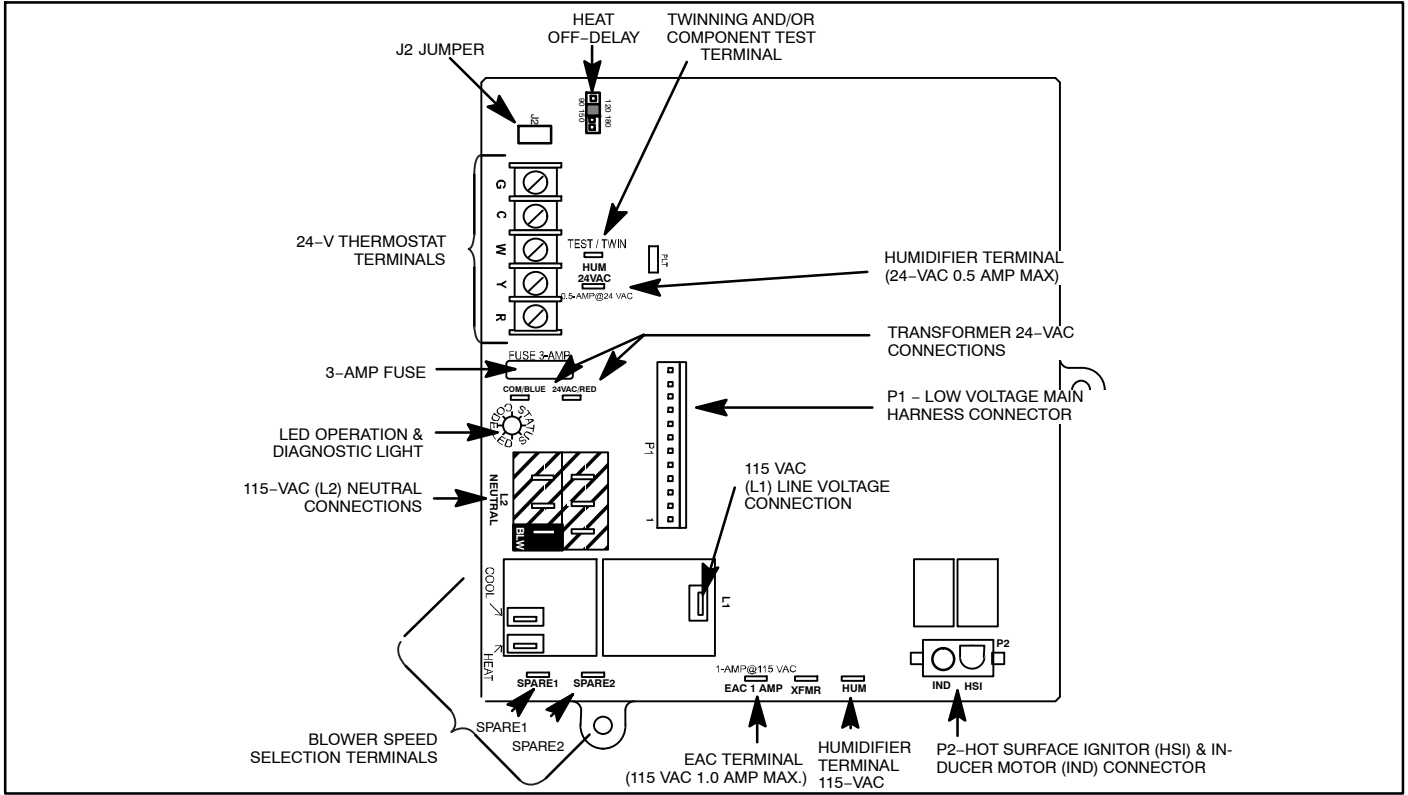
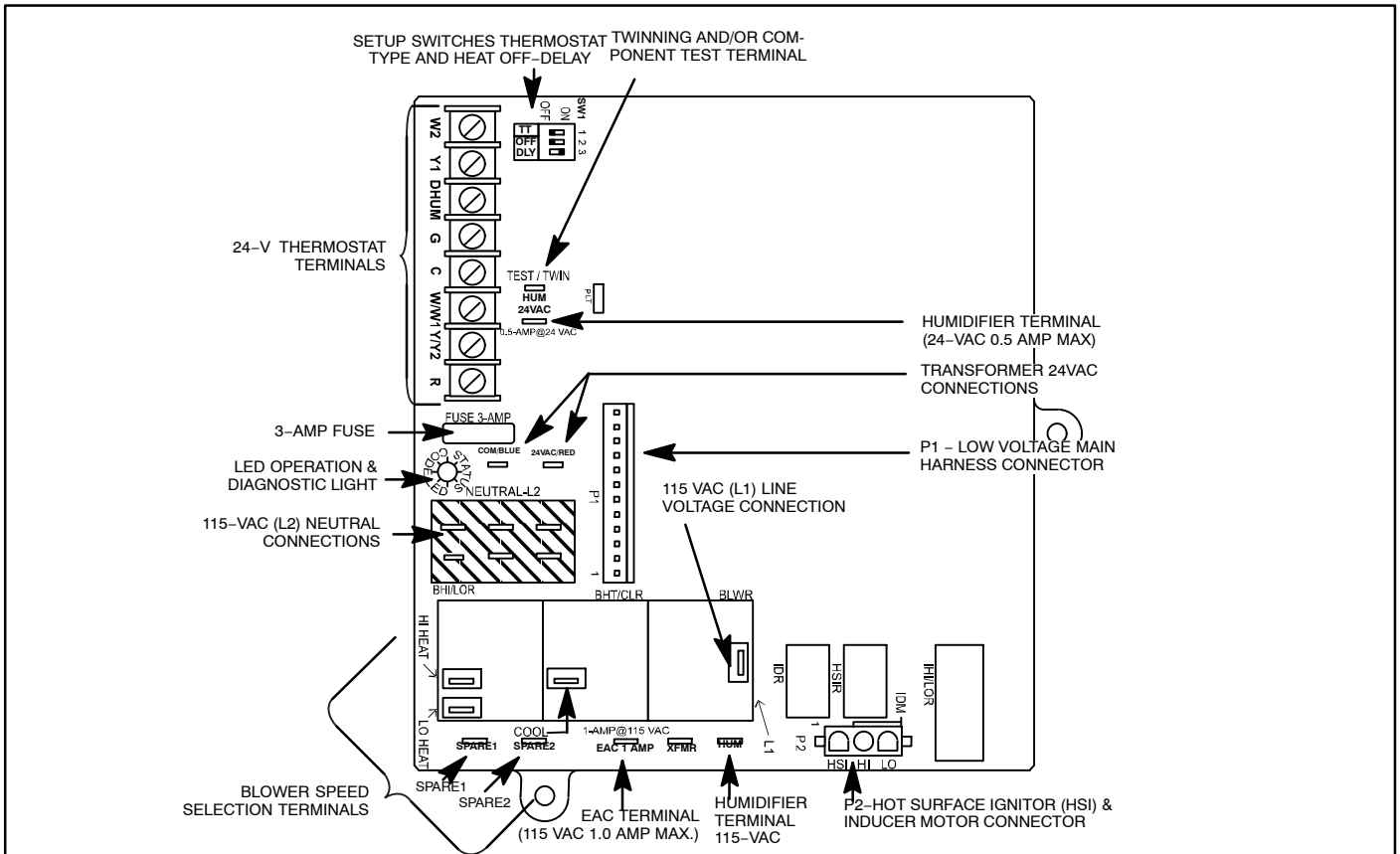

Figure 19 – Two-Stage Furnace Control



PROCEDURE 8 — SEQUENCE OF OPERATION

See Figure 15, Figure 16, or Figure 17 and Figure 20 or Figure 21 for single-speed non-condensing furnace twinning connection and schematic wiring diagrams while reviewing the sequence of operation.

Twinning operation is controlled by LH furnace. The TWIN/TEST and C connection wires ensure the 2 furnaces coordinate their blower operation. When either furnace requires blower operation, both furnaces operate their blowers at the same speed. Both furnaces operate simultaneously in the same mode: heat, cool, or continuous fan. Exceptions can occur if a safety switch on either furnace is activated (such as pressure switch, flame roll-out switch, main limit switch, draft safeguard switch, twinning kit auxiliary limit switch, or flame-proving sensor). In such a case, the other furnace continues to operate unless open switch is the flame roll-out, main limit, or twinning kit auxiliary limit switch, in which case both furnaces respond.

Before performing component test, disconnect TKR yellow wire labeled TEST from LH furnace control TEST/TWIN terminal. After removing yellow wire, component test can be initiated on each furnace individually as stated in Installation, Start-Up, and Operating Instructions.

Single-Stage Heat with Single-Stage Gas-Heat Thermostat

See Section I, Procedure 2 for furnace and kit components used.

1. Single-stage thermostat causes both furnaces to operate in heating mode.
2. Operation in ALL modes is the same for twinned furnaces as for an individual furnace. See furnace Installation, Start-Up, and Operating Instructions for more information on sequence of operation.

Two-Stage Heat with Two-stage Gas-Heat Thermostat

See Section I, Procedure 2 for furnace and kit components used.

1. The two-stage thermostat causes the furnaces to operate in first-stage heat (LH furnace operates in heat while RH furnace blower operates but RH furnace is not heating) or causes the furnaces to operate in second-stage heat (both furnaces operate in heat), depending on whether 1 or 2 thermostat stages are calling for heat.
2. Operation in ALL modes is the same for twinned furnaces as for an individual furnace. See furnace Installation, Start-Up, and Operating Instructions for more information on sequence of operation.

Figure 20 - Wiring Diagram for Single Stage, Non-Condensing Furnaces Models

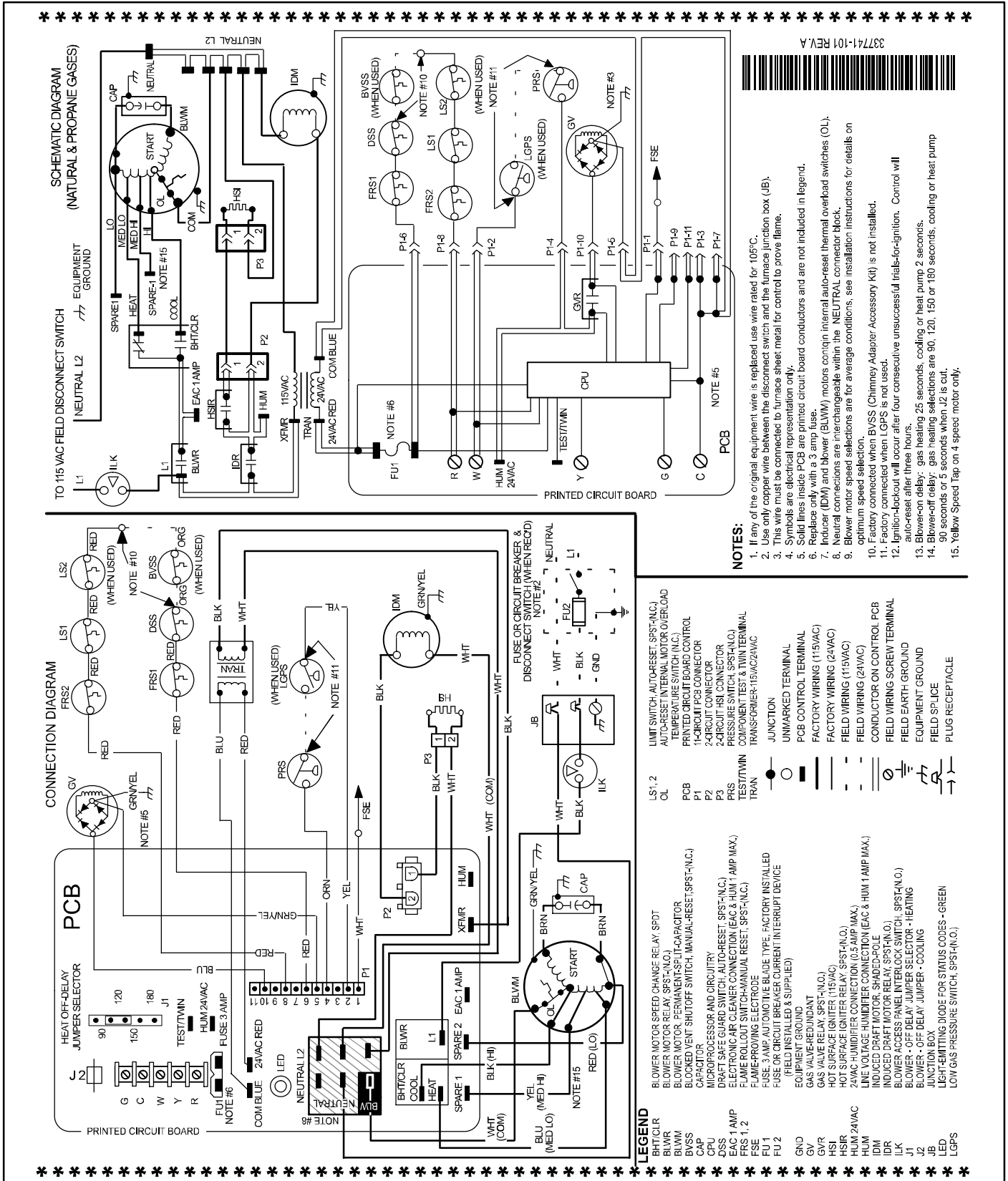

337741-101 REV. A

- NOTES:**
1. If any of the original equipment wire is replaced use wire rated for 105°C.
 2. Use only copper wire between the disconnect switch and the furnace junction box (JB).
 3. This wire must be connected to furnace sheet metal for control to prove flame.
 4. Symbols are electrical representation only.
 5. Solid lines inside PCB are printed circuit board conductors and are not included in legend.
 6. Replace only with a 3 amp fuse.
 7. Inducer (IDM) and blower (BLVM) motors contain internal auto-reset thermal overload switches (OL).
 8. Neutral connections are interchangeable within the NEUTRAL connector block.
 9. Blower motor speed selections are for average conditions, see installation instructions for details on optimum speed selection.
 10. Factory connected when BYSS (Chimney Adapter Accessory Kit) is not installed.
 11. Factory connected when LPS is not used.
 12. Ignition-lockout will occur after four consecutive unsuccessful trials-for-ignition. Control will autor-start after three hours.
 13. Blower-on delay: gas heating 25 seconds, cooling or heat pump 2 seconds.
 14. Blower-off delay: gas heating selections are 90, 120, 150 or 180 seconds, cooling of heat pump 90 seconds or 5 seconds when J2 is cut.
 15. Yellow Speed Tap on 4 speed motor only.

- LEGEND**
- BHTCLR BLWR
 - BLVM
 - BLW
 - BYSS
 - CAP
 - CPU
 - DSS
 - EAC 1 AMP
 - FRS 1, 2
 - FUSE
 - FU 1
 - FU 2
 - GND
 - GV
 - GVR
 - HSI
 - HUM
 - HUM 24VAC
 - IDM
 - IDR
 - J1
 - J2
 - LED
 - LPS
 - LS 1, 2
 - OL
 - PCB
 - P1
 - P2
 - P3
 - PRS
 - TEST/TWIN
 - TRANSFORMER-115VAC/24VAC
 - UNMARKED TERMINAL
 - PCB CONTROL TERMINAL
 - FACTORY WIRING (15VAC)
 - FIELD WIRING (24VAC)
 - FIELD WIRING (115VAC)
 - CONDUCTOR ON CONTROL PCB
 - FIELD WIRING SCREW TERMINAL
 - FIELD EARTH GROUND
 - EQUIPMENT GROUND
 - FIELD SPLICE
 - PLUG RECEPTACLE
 - BLW/MOTOR SPEED CHANGE RELAY (SPDT)
 - BLW/MOTOR RELAY (SPST-N.O.)
 - BLOCKED VENT SHUTOFF SWITCH (MANUAL-RESET) (SPST-N.C.)
 - CAPACITORS
 - MICROPROCESSOR AND CIRCUITRY
 - DRAFT SAFE GUARD SWITCH (AUTO-RESET, SPST-N.C.)
 - ELECTRONIC AIR CLEANER CONNECTION (EAC & HUM 1 AMP MAX.)
 - 24VAC ROLL-OUT SWITCH (MANUAL RESET, SPST-N.C.)
 - FLAME-PROVING ELECTRODE
 - FUSE, 3 AMP, AUTOMATIC BLADE TYPE, FACTORY INSTALLED (FIELD INSTALLED & SUPPLIED)
 - EQUIPMENT GROUND
 - GAS VALVE-REDUNDANT
 - GAS VALVE RELAY (SPST-N.O.)
 - HOT SURFACE IGNITER (115VAC)
 - HOT SURFACE IGNITER RELAY (SPST-N.O.)
 - 24VAC HUMIDIFIER CONNECTION (0.5 AMP MAX.)
 - LINE VOLTAGE HUMIDIFIER CONNECTION (EAC & HUM 1 AMP MAX.)
 - INDUCED DRAFT MOTOR, SHADED-POLE
 - INDUCED DRAFT MOTOR RELAY (SPST-N.O.)
 - BLOWER ACCESS PANEL INTERLOCK SWITCH (SPST-N.O.)
 - BLOWER - OFF DELAY JUMPER - HEATING
 - BLOWER - OFF DELAY JUMPER - COOLING
 - JUNCTION BOX
 - LIGHT-EMITTING DIODE FOR STATUS CODES - GREEN
 - LOW GAS PRESSURE SWITCH (SPST-N.O.)

Figure 21 - Wiring Diagram for Two-Stage, Non-Condensing Furnaces

