



HENRY
TECHNOLOGIES

Product Catalog



DESIGNED FOR PERFORMANCE



henrytech.com

The information contained in this catalog is correct at the time of publication.

Henry Technologies has a policy of continuous product development; we therefore reserve the right to change technical specifications without prior notice.

Extensive changes within our industry have seen products of Henry Technologies being used in a variety of new applications. We have a policy, where possible, to offer research and development assistance to our clients. We readily submit our products for assessment at the development stage, to enable our clients to ascertain product suitability for a given design application.

It remains the responsibility of the system designer to ensure all products used in the system are suitable for the application.

For details of our warranty coverage, please refer to our standard terms and conditions of sale. Copies are available on request.

Date of publication:- April 2016



Introduction	04
Manufacturing, New Product Development & Quality	05
Engineering	06
Notes	07

CONTENTS

FLOW CONTROLS

Ball Valves	08
Check Valves	11
Expansion Valves	14
Flange Unions	15
Packed Shut-Off Valves	17
Packless Valves	25
Rotalock Valves	29
Rotalock Adapters	31

SAFETY DEVICES

By-Pass Valves	32
Pressure Relief Valves	33
Pressure Indicator	36
Rupture Discs	37
Three-Way Dual Shut-Off Valves	39
Transducer Valve	40

COMPRESSOR PROTECTIVE DEVICES

Oil Management Systems	42
Oil Separator Sizing Guidelines	44
Oil Separators	46
Oil Reservoirs	56
Reservoir Pressure Valves	57
Oil Level Regulators	58
Oil Regulator Adapter Kits	60
Oil Level Components	62
Accessories and Replacement Comp	63
Sight Glass Components	64
Oil Filters and Strainers	65
Positive Oil Exchange Valves	67
Discharge Line Mufflers	68
Vibration Eliminators	69

LIQUID MANAGEMENT

Filter Driers	72
Strainers	88
Sight Glasses	90
Liquid Indicators	91
Moisture Indicators	93
Liquid Level Switches	94
Liquid and Oil Level Probes	96
Liquid Refrigerant Receivers	97
Receiver Accessories	111
Suction Line Accumulators	112

INTRODUCTION

Located in America's Heartland, Henry Technologies Inc. manufactures and distributes an extensive range of HVAC/R products for commercial and industrial applications throughout North and South America. Founded in 1914, the company builds on a century of experience to ensure that our customers receive quality components which are reliable, delivered on time, and perform to specification.

With multiple divisions, strategically located throughout the world, the Henry Technologies group continues to grow by developing customer and vendor partnerships that uphold our standards of quality, technical leadership, service, and best overall value for your money. These values have been associated with Henry for the past 100 years, and counting.

In addition to our extensive catalog product offering, Henry Technologies can design and manufacture custom engineered components to meet your specific application. Please contact our sales office at 1-800-96-HENRY to speak with a sales associate, or our technical support hotline at 1-800-627-5148 to consult with an engineer regarding the selection, installation and service of our products.



MANUFACTURING, NEW PRODUCT DEVELOPMENT & QUALITY

MANUFACTURING

The mainstream products of Henry's catalog are manufactured in our US plant located in Chatham, IL. This factory maintains the ability to machine, fabricate, and assemble many of the catalog products. Additional manufacturing support is provided by the other Henry facilities in Scotland, Canada, China, and Australia. A strong outside vendor base has long been established to maintain a high level of ongoing quality expected by our customers.

Henry's manufacturing conviction is to continuously cut cost by reducing waste and routinely investigating new fabrication techniques. These new ideas are welcomed from all employees throughout the organization as it's important to involve all individuals in the growth of a company. While this is a continuing effort we are proud of our achievements and welcome customer visits where ideas may be shared.

NEW PRODUCT DEVELOPMENT

We will be launching a new range of products suitable for transcritical CO₂ systems soon. These products are currently available in Europe and are being developed for the US market. Included in the range are a helical oil separator, helical oil separator-reservoir, oil reservoir and high pressure safety device assemblies (single and dual) all rated to pressures up to 1885PSI/130 Barg. See below images. For more details please contact our sales office at 1-800-96-HENRY.

QUALITY

The Henry brand name is widely known throughout the refrigeration and air conditioning industry. The basis for this relies upon the continuous high quality standards Henry has enforced for all products shipped to its customers. To continuously meet these high standards every process from design to fabrication is regularly assessed with an emphasis on continuous improvement.

Henry maintains various standards that function as a foundation to the quality system, including but not limited to ISO 9001:2008, ASME, Pressure Equipment Directive, and Underwriters Laboratories. Product quality and reliability are the forefront to long lasting customer relationships.



ENGINEERING

ENGINEERING

The Henry Technologies' engineering group provides ongoing technical support for our product while attending to all the technical challenges of manufacturing support and new product development. We believe it is important for our engineers to work directly with our customers' technical teams for new product specifications, installation, and inclusion of our 3D Solid Model parts into their systems.

Our engineering team uses the latest in CAD software for product design and prototype simulation testing, including Finite Element Analysis (FEA) and Computational Fluid Dynamics (CFD).

GENERAL INFORMATION

All products are 100% tested to assure they are leak free and in some cases a functional test is performed to insure high reliability. All pressure vessels are powder coated to provide excellent corrosion protection, surpassing a 500 hour ASTM B117 salt spray test.

Variations to many products in the catalog are available. We're able to accommodate specific OEM designs that are derivatives to our core catalog line. Contact Henry Sales for a custom quotation at: 1-800-96-HENRY.

Technical notes

1. All dimensions stated in catalog are nominal. All product dimensions are subject to manufacturing tolerance.
2. Catalog line drawings only show main dimensions and features. If additional information is required, please contact the factory. 3D solid models and 2D drawings are available on request.
3. Abbreviations:-
 - MWP = Maximum working pressure (allowable)
This is the same as the Product Design Pressure.
 - NPT = American National Standard Taper Pipe Thread
 - SAE = Straight threaded connection, in accordance with SAE J513-92; ASME B1.1-89
 - ODS = Female soldering connection. This size is equal to the outside diameter of the mating pipe.
4. All weights listed in the catalog are net dry weights.

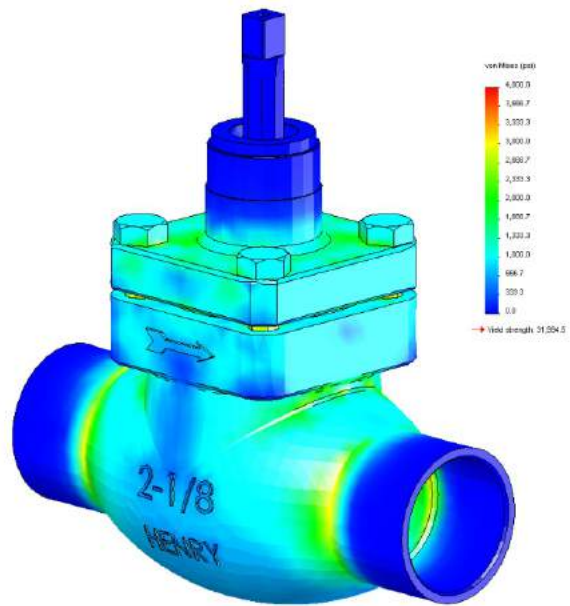

FEA - PACKED GLOBE VALVE BONNET

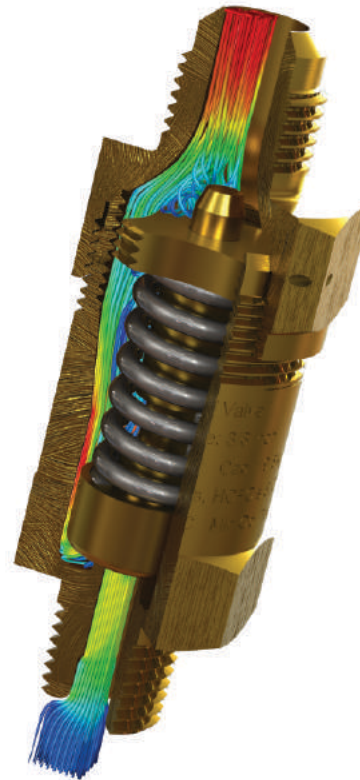

CFD - PRESSURE RELIEF VALVE

NOTES

BALL VALVES

The function of a Ball Valve is to provide isolation in liquid and gas applications with single or bi-directional flow where little restriction is desired.

Applications

Ball valves are used in a wide variety of refrigeration and air conditioning applications. They can be used for both liquid and gas applications. This type of valve is commonly used for isolating purposes. 937 series ball valves are suitable for use with HCFC and HFC refrigerants and their associated oils, as well as other industrial fluids non-corrosive to brass, steel, copper, Teflon and synthetic rubber.

Main Features

Construction features

- Bi-directional flow
- ODS connections
- Indicator on stem shows valve position - open or closed
- Fully opened or closed with quarter turn of stem
- Positive stem stop ensures precise positioning in the open or closed position
- Blow-out proof stem
- Ball cavity vented to prevent over-pressure
- Schrader valve included
- Mounting pad

Sealing integrity features

- Premium quality PTFE ball seals
- Double O-ring stem seal design
- Premium quality neoprene stem O-rings seals
- Neoprene cap seal - acts as a secondary seal

Technical Specifications

Maximum working pressure = 698 PSI (48.0 Bar)

Allowable operating temperature = -40°F to +248°F (-40°C to +120°C)

Henry Technologies' 937 Series Ball Valves are UL and C-UL Listed by Underwriters Laboratories, Inc. Valves 1-3/8 and larger are CE marked in accordance with PED. Additionally, the Ball Valves are designed and registered for use in Canada. Please contact Technical Support at 1-800-627-5148 for CRN details and list of approved provinces and territories.

Materials of Construction

The components: valve body, valve body adaptor, ball and seal cap are made from brass. The stem is made from plated steel. The pipe extensions are made from copper. The ball seals are made from virgin PTFE, stem O-rings and cap seal from neoprene.



CRN



Installation - Notes

1. The valve body must be protected against excessive heat during installation, to prevent damage to the seals.
2. Full instructions are given in the Product Instruction Sheet, included with each valve.

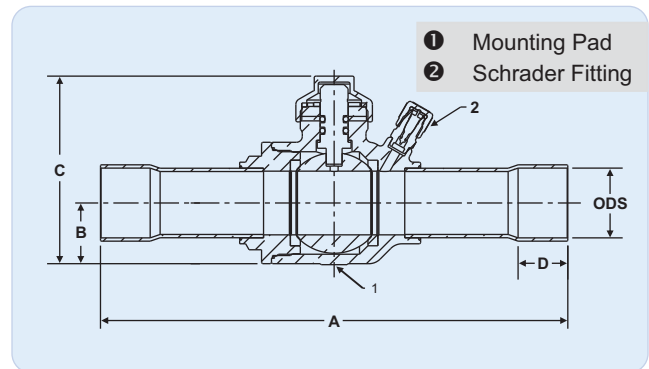

Part No	ODS (inch)	Dimensions (inch)				Port Size (inch)	Cv	Weight (lbs)
		A	B	C	D			
937202	1/4	6.50	0.63	2.13	0.32	0.50	2.09	0.73
937203	3/8	6.50	0.63	2.13	0.32	0.50	4.28	0.73
937204	1/2	6.50	0.63	2.13	0.39	0.50	6.96	0.73
937205	5/8	6.50	0.63	2.13	0.51	0.50	13.82	0.73
937307	7/8	7.24	0.83	2.64	0.75	0.75	30.13	1.41
937409	1 1/8	8.50	0.98	2.99	0.91	1.00	60.96	2.14
937511	1 3/8	9.25	1.22	3.70	0.98	1.25	84.72	3.48
937613	1 5/8	10.00	1.54	4.29	1.10	1.50	210.8	5.56
937617	2 1/8	11.38	1.85	5.20	1.34	2.00	283.39	10.14
937721*	2 5/8	12.87	1.85	5.20	1.56	2.00	236.67	11.11
937725*	3 1/8	14.37	2.36	6.06	1.65	2.50	322.17	19.25

*Reduced Port - Full Port models available upon request

BALL VALVES & BALL VALVES WITH SIGHT GLASS (BVSG)

■ BALL VALVE



■ BALL VALVE WITH SIGHT GLASS



Applications

Ball valves are used in a wide variety of refrigeration and air conditioning applications. They can be used for both liquid and gas applications. This type of valve is commonly used for isolating purposes. All valves are suitable for CO₂, HCFC and HFC refrigerants along with their associated oils.

The new product combines the traditional ball valve with a sight glass and moisture indicator. A typical for this combination product is in the liquid refrigerant line. The ball valve is used for isolating purposes; the sight glass for a visual display inside the line and the moisture indicator monitors the moisture content in the system.

Main Features

Construction features

- Bi-directional flow
- Indicator on stem shows valve position - open or closed
- Positive stem stop ensures precise positioning in the open or closed position
- Blow-out proof stem
- Ball cavity vented to prevent over-pressure
- Vented seal cap
- Schrader valve option
- Mounting pad
- Large sight glass (BVSG only)
- Positive color contrast indicator (BVSG only)
- Plastic protection cap for sight glass supplied as standard (BVSG only)

Sealing integrity features

- Premium quality PTFE ball seals
- Double O-ring stem seal design
- Premium quality neoprene stem O-ring seals
- Neoprene cap seal - acts as a secondary seal
- Hermetically sealed sight glass (BVSG only)

Technical Specifications

Maximum working pressure = 698 PSI (48.0 Bar)

Allowable operating temperature = -40°F to +248°F (-40°C to +120°C)

(Higher pressures available on request)

Materials of Construction

The valve body, valve body adaptor, ball and seal cap are made from brass. The stem is made from plated steel. The pipe extensions are made from copper. The ball seals are made from virgin PTFE, stem O-rings and cap seal from neoprene.

Installation - Notes

- 1 The valve body must be protected against excessive heat during installation, to prevent damage to the seals.
2. Full instructions are given in the Product Instruction Sheet, included with each valve.

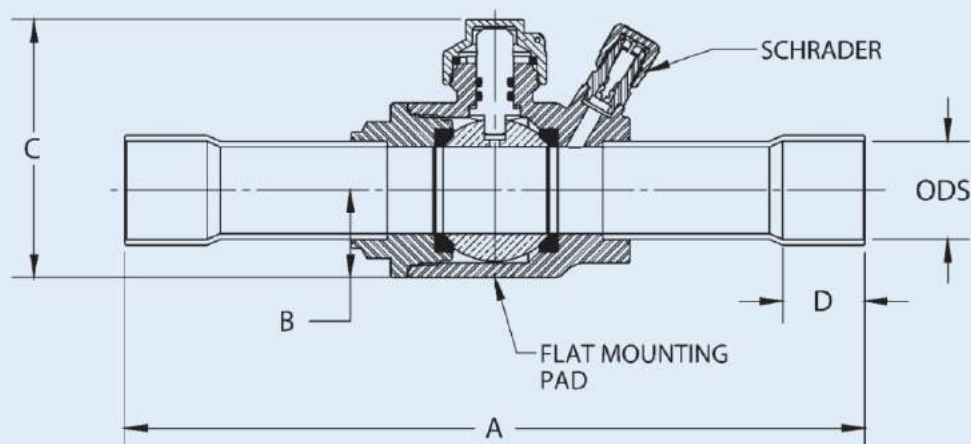

Ball Valves Imperial

Part No		ODS (inch)	Dimensions (inch)				Mounting pad hole thread details - 2 off	Port Size (inch)	Weight (lbs)	MWP (PSI)	Cv	CE Cat
Standard	Schrader Valve		A	B	C	D						
907202	937202	1/4	6.50	0.63	2.13	0.32	8-36 UNF-2B x 0.79 pitch	0.50	0.73	700	2.09	SEP
907203	937203	3/8	6.50	0.63	2.13	0.32	8-36 UNF-2B x 0.79 pitch	0.50	0.73	700	4.28	SEP
907204	937204	1/2	6.50	0.63	2.13	0.39	8-36 UNF-2B x 0.79 pitch	0.50	0.73	700	6.96	SEP
907205	937205	5/8	6.50	0.63	2.13	0.51	8-36 UNF-2B x 0.79 pitch	0.50	0.73	700	13.82	SEP
907306	937306	3/4	7.24	0.83	2.64	0.51	8-36 UNF-2B x 1.26 pitch	0.75	1.37	700	20.89	SEP
907307	937307	7/8	7.24	0.83	2.64	0.75	8-36 UNF-2B x 1.26 pitch	0.75	1.41	700	30.14	SEP
907409	937409	1 1/8	8.50	0.98	2.99	0.91	10-32 UNF-2B x 1.58 pitch	1	2.09	700	60.98	SEP
907511	937511	1 3/8	9.25	1.22	3.70	0.98	10-32 UNF-2B x 1.89 pitch	1.25	3.35	700	84.74	Cat I
907613	937613	1 5/8	10.00	1.54	4.29	1.10	1/4"-28 UNF-2B x 2.37	1.5	5.38	700	210.87	Cat I
907617	937617	2 1/8	11.38	1.85	5.20	1.34	1/4"-28 UNF-2B x 2.96	2	10.10	700	283.48	Cat I
907721	937721	2 5/8	12.87	1.85	5.20	1.46	1/4"-28 UNF-2B x 2.96	2	11.11	700	236.73	Cat I
907721FP	937721FP	2 5/8	14.37	2.36	6.06	1.46	1/4"-28 UNF-2B x 2.96	2.50	19.25	700	299.40	Cat I
907725	937725	3 1/8	14.37	2.36	6.06	1.65	1/4"-28 UNF-2B x 2.96	2.50	19.25	700	322.28	Cat I
907825FP	-	3 1/8	16.54	2.83	7.01	1.69	5/16-24 UNF-2B x 4.10	3.15	40.12	700	417.76	Cat I
907829	-	3-5/8	16.54	2.83	7.01	1.69	5/16-24 UNF-2B x 4.10	3.15	40.12	700	508.28	Cat I
937833	-	4-1/8	16.54	2.83	7.01	2.20	5/16-24 UNF-2B x 4.10	3.15	40.12	700	517.23	Cat I

Ball Valves with Sight Glass

Part No		ODS (inch)	Dimensions (inch)				Mounting pad hole thread details - 2 off	Port Size (inch)	Weight (lbs)	MWP (PSI)	Cv	CE Cat
Standard	Schrader Valve		A	B	C	D						
907202SG	937202SG	1/4	6.50	0.63	2.15	0.31	8-36 UNF-2B x 0.79 pitch	0.50	0.93	700	2.09	SEP
907203SG	937203SG	3/8	6.50	0.63	2.15	0.31	8-36 UNF-2B x 0.79 pitch	0.50	0.93	700	4.28	SEP
907204SG	937204SG	1/2	6.50	0.63	2.15	0.39	8-36 UNF-2B x 0.79 pitch	0.50	0.93	700	6.96	SEP
907205SG	937205SG	5/8	6.50	0.63	2.15	0.51	8-36 UNF-2B x 0.79 pitch	0.50	0.93	700	13.82	SEP
907206SG	937206SG	3/4	7.24	0.83	2.63	0.79	8-36 UNF-2B x 1.26 pitch	0.75	1.76	700	20.89	SEP
907207SG	937207SG	7/8	8.50	1.00	2.97	0.94	8-36 UNF-2B x 1.26 pitch	0.75	1.76	700	30.14	SEP
907409SG	937409SG	1 1/8	9.25	1.22	3.73	0.98	10-32 UNF-2B x 1.58 pitch	1	2.65	700	60.98	SEP

Moisture Colour Table

Refrigerant	Moisture content (parts per million)			
	Temp (°F)	Indicator Colour		
		Green	Chartreuse	Yellow
R404A	75	below 20	20-100	above 100
	100	below 35	35-130	above 130
	125	below 45	45-200	above 200
R410A	75	below 20	20-100	above 100
	100	below 30	30-120	above 120
	125	below 50	50-150	above 150
R134a	75	below 30	30-90	above 90
	100	below 50	50-120	above 120
	125	below 70	70-150	above 150
R22	75	below 20	20-85	above 85
	100	below 30	30-90	above 90
	125	below 45	45-110	above 110
R744	75	below 15	15-80	above 80
	100	below 20	20-90	above 90
	125	below 35	35-110	above 110

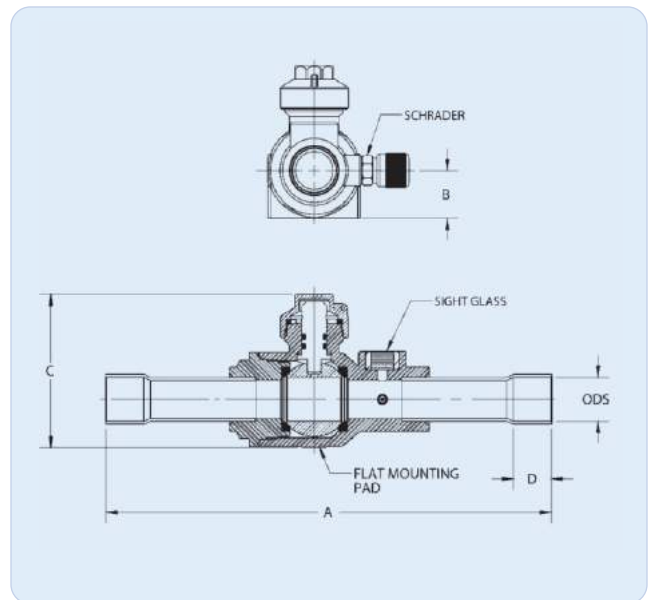

CHECK VALVES MAGNI-CHEK

The function of a Check Valve is to allow fluid flow in one direction only.

Applications

Henry Technologies' Magni-Chek Valves are used in discharge lines to prevent flow from the Condenser to the Compressor during the "off" cycle, or to prevent flow from an operating Compressor to one that is idle. They are also used in liquid lines to prevent reverse flow through the unused expansion device on heat pump systems, or to prevent backup into the low pressure liquid line of a recirculating system during a defrost period. Henry Technologies' Magni-Chek Valves are suitable for use with HFC and HCFC refrigerants and their associated oils, as well as other industrial fluids non-corrosive to copper, brass, steel, and aluminum.

Main Features

- Designed for maximum flow and minimal pressure drop
- ODS connections
- Negligible loss in system efficiency
- Hermetically sealed copper body
- Stable platform with no chance of a leak
- Efficient sealing with a negligible leak rate
- Able to be installed in any position
- Built in 30 mesh strainer to remove debris from the system and extend the valve service life
- Suitable for a wide range of applications

Technical Specifications

Maximum working pressure = 650 to 800 PSI (45 Bar to 55 Bar)

See table below

Allowable operating temperature = -20°F to +250°F (-29°C to +121°C)

Magni-chek Valves are USR and CNR recognized by Underwriters Laboratories, Inc.

Valves 1-3/8 ODS and larger are CE marked in accordance with PED.



Materials of Construction

The valve body is made from solid copper. The seat is made from brass. The retainer is made from aluminum. The flapper and screen are made from stainless steel.

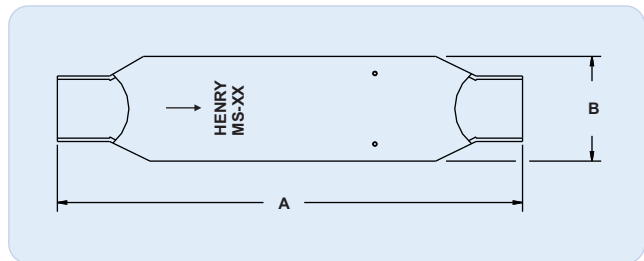

Part No	Description	MWP (PSI)	ODS (inch)	Dimensions (inch)		Capacity - Suction Kw			Capacity - Liquid Kw		
				A	B	R22	R134a	R404A	R22	R134a	R404A
F6306	MS-4	800	1/4	4.00	7/8	1.10	0.80	0.90	9.50	8.80	6.80
F6307	MS-6	800	3/8	4.00	7/8	2.20	1.60	2.00	19.90	18.30	14.20
F6308	MS-8	700	1/2	5.00	1 1/8	6.00	4.40	5.30	53.80	49.40	38.20
F6309	MS-10	700	5/8	5.00	1 1/8	6.70	4.90	5.90	60.00	55.10	42.60
F6310	MS-12	700	3/4	7.00	1 5/8	12.50	9.20	11.00	112.20	103.10	79.70
F6311	MS-14	700	7/8	7.00	1 5/8	17.00	12.50	15.00	152.80	140.40	108.50
F6312	MS-18	700	1 1/8	8.38	2 1/8	29.60	21.70	26.10	265.90	244.30	188.80
F6313	MS-22	700	1 3/8	9.38	2 5/8	36.50	26.80	32.20	327.90	301.30	232.50
F6314	MS-26	700	1 5/8	10.50	3 1/8	62.30	45.80	54.90	560.10	514.60	397.70
F6315	MS-34	700	2 1/8	12.00	3 5/8	108.20	79.50	95.50	973.30	894.30	691.10
F6316	MS-42	650	2 5/8	13.00	4 1/8	145.20	106.70	128.10	1,305.90	1,200.00	927.30
F6085	MS-50	650	3 1/8	13.00	4 1/8	145.20	106.70	128.10	1,305.90	1,200.00	927.30

CHECK VALVES

Straight Through Design

The function of a Check Valve is to allow fluid flow in one direction only.

Applications

Henry Technologies' Check Valves are suitable for use with HCFC and HFC refrigerants and their associated oils, as well as other industrial fluids non-corrosive to brass, steel, copper, Teflon and synthetic rubber.

A typical application is to install a Check Valve downstream of an Oil Separator. This prevents condensed liquid refrigerant returning down the Discharge Line and into the Separator.

The 119 and 120 series Check Valves are not suitable for discharge lines of reciprocating compressors.

Main Features

- Robust design
- Flow direction arrow
- Quiet and efficient operation
- Minimal opening pressure
- Copper extensions on 120 series

Technical Specifications

Maximum working pressure = 500 PSI (34.5 Bar)

Allowable operating temperature = -20°F to +200°F (-29°C to +93°C)

Using the standard spring, Henry Technologies' Check Valves will start to open at 0.5 PSI and be fully open at 5 PSI pressure differential. Contact Technical Support at 1(800) 627-5148 for alternative spring options.

Series 119 and 120 Check Valves are UR and CNR recognized by Underwriters Laboratories, Inc.

Materials of Construction

The valve body and piston are made from brass. The spring is made from stainless steel. The seat is made from neoprene. The extensions on the 120 series are made from copper.



Installation - Notes

1. Valves must be installed in accordance with the flow direction arrow.
2. The valve bodies and valve internals of series 120 valves must be protected against damage during brazing. Series 120 valves should not be disassembled for brazing. Full instructions are given in the Product Instruction Sheet, included with each valve.
3. Discharge Check Valves should be positioned as far from the compressor as possible.

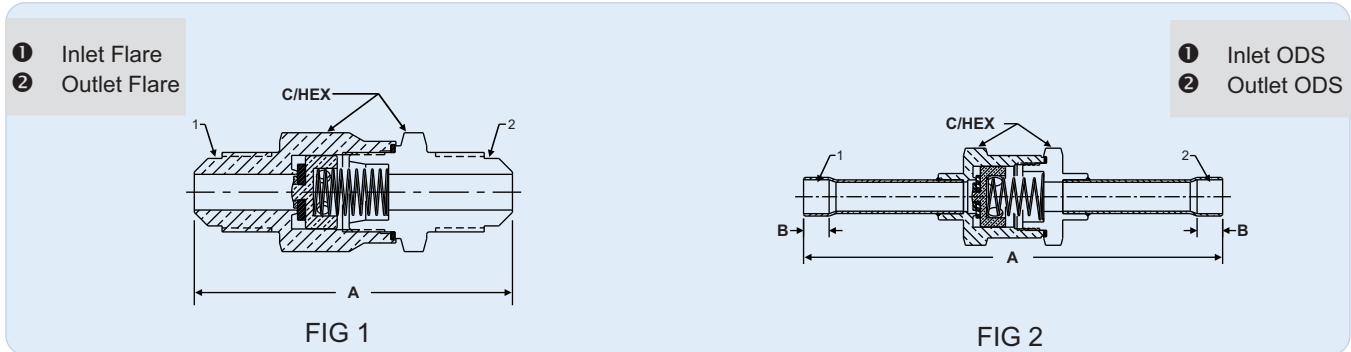

Part No	Fig No	Conn Size (inch)	Dimensions (inch)			Cv	Weight (lbs)
			A	B	C/HEX		
119-1/4	1	1/4 SAE Flare	2.26	-	13/16	0.44	0.22
119-3/8	1	3/8 SAE Flare	2.51	-	13/16	0.94	0.26
119-1/2	1	1/2 SAE Flare	3.00	-	1-1/4	2.80	0.28
120-3/8	2	3/8 ODS	6.04	0.31	13/16	0.85	0.28
120-1/2	2	1/2 ODS	6.23	0.38	1-1/4	1.99	0.57
120-5/8	2	5/8 ODS	6.41	0.50	1-1/4	3.05	0.64
120-7/8	2	7/8 ODS	7.44	0.75	1-1/2	5.80	1.06

CHECK VALVES

Globe Design

The function of a Check Valve is to allow fluid flow in one direction only.

Applications

A typical application is to install a Check Valve downstream of an Oil Separator. This prevents condensed liquid refrigerant from returning down the discharge line and into the Separator. Henry Technologies' Check Valves are suitable for use with HCFC and HFC refrigerants and their associated oils, as well as other industrial fluids non-corrosive to brass, steel, copper, Teflon and synthetic rubber.

Main Features

- Robust design
- ODS connections
- Flow direction arrow
- Quiet and efficient operation
- Minimal opening pressure

Technical Specifications

Maximum working pressure = 500 PSI (34.5 Bar)

Allowable operating temperature = -20°F to +300°F (-29°C to +149°C)

Typically, Henry Technologies' Check Valves will start to open at 0.5 PSI and be fully open at 5 PSI pressure differential.

Series 116 and 205 Check Valves are UR and CNR recognized by Underwriters Laboratories, Inc.

Materials of Construction

The valve body on the 116 series is made from brass and the valve body on the 205 series is made from cast bronze. The piston is made from brass. The spring is made from stainless steel. The seat is made from PTFE.



- 1 Inlet ODS
- 2 Outlet ODS

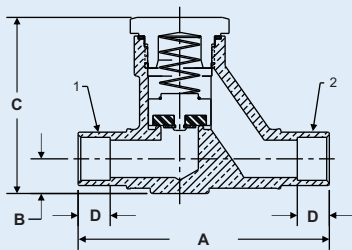

FIG 1

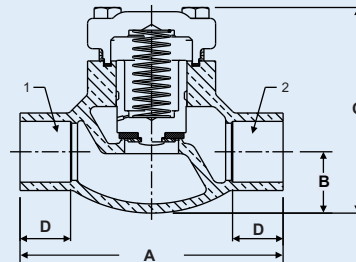

FIG 2

Part No	Fig No	ODS (inch)	Dimensions (inch)				Cv	Weight (lbs)
			A	B	C	D		
116003	1	3/8	2.94	0.41	2.06	0.31	1.5	0.53
116004	1	1/2	2.94	0.41	2.06	0.38	3.1	0.51
116005	1	5/8	2.94	0.41	2.06	0.50	3.9	0.48
116007	1	7/8	3.88	0.63	3.15	0.88	8.3	2.04
205-7/8	2	7/8	4.25	0.97	3.16	0.75	5.2	2.73
205-1-1/8	2	1 1/8	4.88	1.16	3.85	0.94	7.2	4.41
205-1-3/8	2	1 3/8	5.38	1.25	4.25	1.00	10.1	6.04
205-1-5/8	2	1 5/8	6.50	1.50	5.08	1.13	13.0	9.32
205-2-1/8	2	2 1/8	8.50	2.00	6.17	1.50	21.5	17.10
205-2-5/8	2	2 5/8	11.00	2.25	7.20	1.69	35.7	27.43

Installation - Notes

- Valves must be installed in accordance with the flow direction arrow.
- The valve bodies and valve internals must be protected against damage during brazing. Piston must be removed for brazing. Full instructions are given in the Product Instruction Sheet, included with each valve.
- Series 116 valves can be installed in any position except bonnet down. Series 205 valves sizes 7/8" - 1-3/8" can be installed in any position except bonnet down, however, 205 valves sizes 1-3/8" - 2-5/8" MUST be installed with bonnet positioned upwards. For all models, the recommended bonnet position is upwards.
- Discharge Check Valves should be positioned as far from the compressor as possible.

EXPANSION VALVES

The function of an Expansion Valve is to meter liquid refrigerant and induce a large pressure drop causing the refrigerant to cool rapidly.

Applications

Expansion Valves are used immediately prior to the evaporator in a refrigeration or air conditioning system. These valves are suitable for use with ammonia, HCFC and HFC refrigerants and their associated oils, as well as other industrial fluids non-corrosive to steel and ductile iron.

Main Features

- Backseating stem to allow for replacing stem packing while under pressure
- Four bolt bonnet flange design
- Internal replacement parts available
- NPT connections

Technical Specifications

Maximum working pressure = 400 PSI (27.6 Bar)

Allowable operating temperature = -20°F to +275°F (-29°C to +135°C)

Materials of Construction

The body and bonnet are made from ductile iron. The stem is made from stainless steel. The seat insert is made from cold rolled steel. The bonnet gasket is made from Garlock 2930.

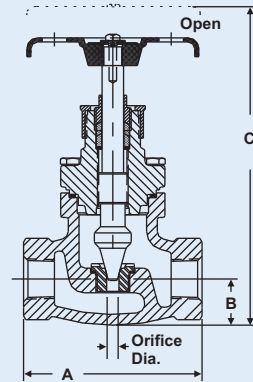

Stem Turns From Closed	*Cv Value						
	1/4	1/2	3/4	1	2	3	Full Open
Valve P/N							
320F-E	0.09	0.22	0.40	0.56	1.00	1.28	1.58
330F-E	0.20	0.42	0.71	0.95	1.50	2.09	2.60
340F-E	0.34	0.81	1.21	1.62	2.89	3.80	4.51

*Water GPM at 1 psi pressure drop at +86°F

Part No	NPT Conn (inch)	Dimensions (inch)			Orifice Diameter (inch)	Weight (lbs.)
		A	B	C		
320F-E	1/2	3.63	0.94	6.17	0.25	2.5
330F-E	3/4	3.63	0.94	6.17	0.38	2.5
340F-E	1	4.13	1.10	6.30	0.50	3.5

FLANGE UNIONS

Flange Unions offer a convenient method for connecting pipe and installing shut-off valves with identical groove patterns.

Applications

Flange Unions are a practical alternative to weld or screw end connections. Where shut-off valves are used in conjunction with the flanges the valves may be replaced without performing any cutting operations. NPT and Socket Weld Flanges are suitable for use with ammonia, HCFC and HFC refrigerants and their associated oils, as well as other industrial fluids non-corrosive to steel and Garlock #2930. Lead gaskets are also available for two bolt NPT and Socket Weld Flanges for chlorine service.

ODS Flanges are suitable for use with HCFC and HFC refrigerants and their associated oils, as well as other industrial fluids non-corrosive to steel, copper and Garlock #2930.

Main Features

- Two bolt flange design, connection sizes 1/2" to 1" nominal
- Four bolt flange design, connection sizes 1" to 4" nominal
- Connection types available: NPT, Socket Weld and ODS
- All flanges with the same nominal connection size and number of bolts are interchangeable
- All flange dimensions of the same type and nominal size are identical to those used on Henry Valve flanged handwheels and seal cap valves

Technical Specifications

NPT and Socket Weld Series

Maximum working pressure sizes 1/2" to 2" = 1500 PSI (103.4 Bar)

Maximum working pressure sizes 2-1/2" to 4" = 500 PSI (34.5 Bar)

Allowable operating temperature = -20°F to +275°F (-29°C to +135°C)

ODS Series

Maximum working pressure = 500 PSI (34.5 Bar)

Allowable operating temperature = -20°F to +275°F (-29°C to +135°C)

Materials of Construction

NPT and Socket Weld Series

The flange body is made from ASTM A105 forged steel. The bolts are made from SAE Grade 5 steel. The gasket is made from Garlock #2930.

ODS Series

The flange body is made from ASTM A105 forged steel. The connections are made from solid copper. The gasket is made from Garlock #2930.



Additional Information

1. For single flanges only, add the suffix letter "F" (female) or "M" (male) to the flanges union catalog number.
2. Hardware kits are available separately; includes nuts, cap screws, and gasket.
3. Flanges for installation onto Henry valves up to 4" nominal should order the flanged union catalog number. The appropriate number of additional bolts and nuts are provided with all flanged valves.
4. Flange kits include two gaskets.
5. Flanges designated for chlorine service order lead gaskets, available only on 2-bolt designs. Lead Gasket part number is 5-023-097.

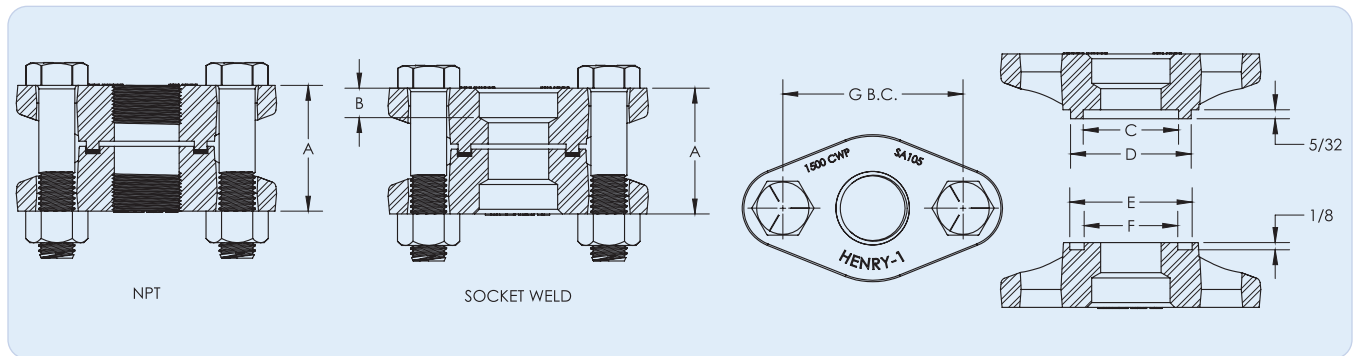

OVAL TYPE WITH FEMALE PIPE THREAD & SOCKET WELD DESIGN

Part No		Conn Size (inch)	Dimensions (inch)							Weight (lbs)	
NPT	Socket Weld		A	B	C	D	E	F	G	NPT	Socket Weld
O2PT-1X1/2	O2SW-1X1/2	1/2	2.19	0.38	1.66	2.09	2.13	1.63	3.13	3.75	3.75
O2PT-1X3/4	O2SW-1X3/4	3/4	2.19	0.51	1.66	2.09	2.13	1.63	3.13	4.00	4.00
O2PT-1	O2SW-1	1	2.19	0.51	1.66	2.09	2.13	1.63	3.13	3.50	3.50

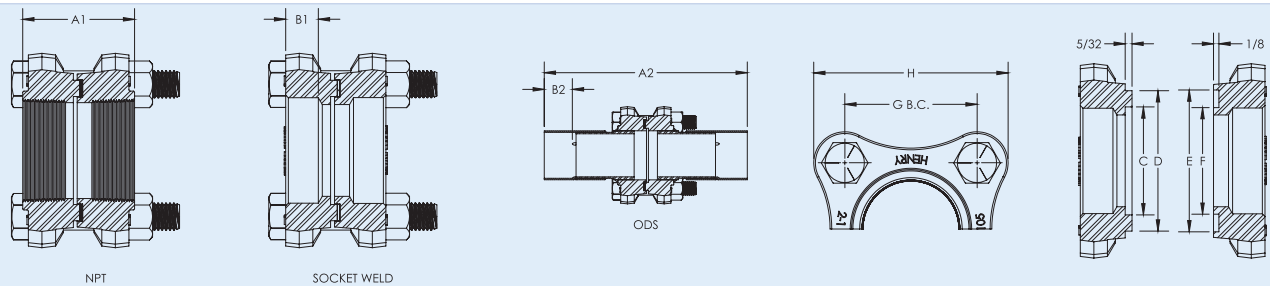

SQUARE TYPE WITH NPT & SOCKET WELD CONNECTIONS

Part No		Conn Size (inch)	Dimensions (inch)								Weight (lbs)	
NPT	Socket Weld		A1	B1	C	D	E	F	G	H	NPT	Socket Weld
S2PT-1 1/4X1	S2SW-1 1/4X1	1	2.20	0.50	1.85	2.28	2.31	1.81	2.38	3.75	5.25	5.25
S2PT-1 1/4	S2SW-1 1/4	1 1/4	2.20	0.75	1.85	2.28	2.31	1.81	2.38	3.75	5.25	5.25
S2PT-2X1-1/2	S2SW-2X1-1/2	1 1/2	2.59	0.75	2.50	3.25	3.28	2.47	3.06	4.50	9.00	8.75
S2PT-2	S2SW-2	2	2.59	0.75	2.50	3.25	3.28	2.47	3.06	4.50	7.75	7.50
N/A	S2SW-2-1/2	2 1/2	2.97	1.00	3.00	3.75	3.78	2.97	4.00	5.63	N/A	13.25
N/A	S2SW-3	3	3.19	1.13	3.63	4.38	4.41	3.59	4.13	6.00	N/A	15.75
N/A	S2SW-4	4	3.19	1.13	4.75	5.50	5.53	4.72	5.00	7.00	N/A	22.00

SQUARE TYPE WITH ODS CONNECTIONS

Part No	Conn Size (inch)	Dimensions (inch)								Weight (lbs)
ODS		A2	B2	C	D	E	F	G	H	ODS
S2OD-1-3/8	1 3/8	7.44	0.97	1.85	2.28	2.31	1.81	2.38	3.75	5.75
S2OD-2X1-5/8	1 5/8	8.40	1.09	2.50	3.25	3.28	2.47	3.06	4.50	9.75
S2OD-2-1/8	2 1/8	9.40	1.34	2.50	3.25	3.28	2.47	3.06	4.50	8.75
S2OD-2-5/8	2 5/8	10.40	1.47	3.00	3.75	3.78	2.97	4.00	5.63	15.00
S2OD-3-1/8	3 1/8	11.34	1.66	3.63	4.38	4.41	3.59	4.13	6.00	18.50
S2OD-4-1/8	4 1/8	13.50	2.16	4.75	5.50	5.53	4.72	5.00	7.00	28.00

*O.D. Solder connections are suitable for halocarbon refrigerants only

Hardware Kits

Flange Union	Kit (Nuts, Cap Screws, Gasket)
O2PT-1X1/2	8-006-033
O2PT-1X3/4	8-006-033
O2PT-1	8-006-033
O2SW-1X1/2	8-006-033
O2SW-1X3/4	8-006-033
O2SW-1	8-006-033
S2PT-1-1/4X1	8-006-034
S2PT-1-1/4	8-006-034
S2PT-2X1-1/2	8-006-035
S2PT-2	8-006-035
S2OD-1-3/8	8-006-034
S2OD-2X1-5/8	8-006-035
S2OD-2-1/8	8-006-035
S2OD-2-5/8	8-006-036
S2OD-3-1/8	8-006-037
S2OD-4-1/8	8-006-037
S2SW-1-1/4X1	8-006-034
S2SW-1-1/4	8-006-034
S2SW-2X1-1/2	8-006-035
S2SW-2	8-006-035
S2SW-2-1/2	8-006-036
S2SW-3	8-006-037
S2SW-4	8-006-037

PACKED SHUT-OFF VALVES

Packed, Globe, Back-Seating Design

The function of a Globe Valve is to control flow or provide isolation in liquid or gas applications that may require frequent use.

Applications

Henry Technologies' Packed Valves are used in a variety of air conditioning and refrigeration applications for isolating, flow control, charging and purging. The 203 series Globe Valves are suitable for use with HCFC and HFC refrigerants and their associated oils, as well as other industrial fluids non-corrosive to brass, steel, Teflon and synthetic rubber.

Main Features

- Brass construction
- ODS connections
- Compact design
- Backseating stem to allow for replacing stem packing while under pressure
- Non-rotating self-aligning swivel seat disc with fully retained Teflon seat ring

Technical Specifications

Maximum working pressure = 450 PSI (31 Bar)

Allowable operating temperature = -40°F to +275°F (-40°C to +135°C)

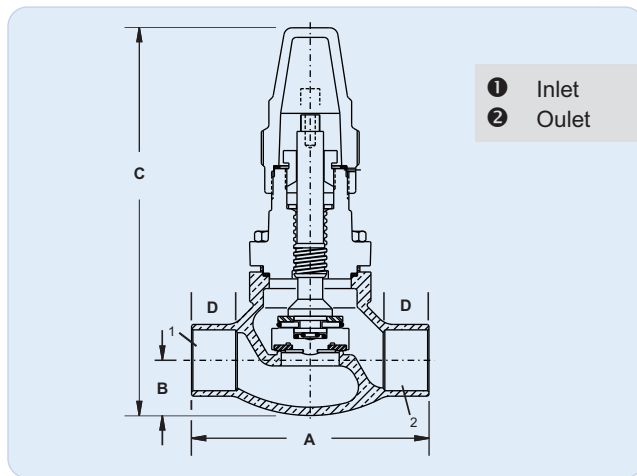

Materials of Construction

The valve body and bonnet are made from bronze and brass respectively. The stem is made from stainless steel. The seat seal material is PTFE. A graphite compound is used for the packing gland. The seal cap is made from molded plastic.

Installation - Notes

Valves must be protected from heat damage during installation. Full instructions are given in the Product Instruction Sheet, included with each valve.

	Part No	ODS (inch)	Dimensions (inch)				Weight (lbs)
			A	B	C	D	
Backseating	2030-AA	7/8	4.25	0.98	5.59	0.75	3.00
	2030-BA	1 1/8	4.88	1.14	5.87	0.94	4.70
	2031	1 3/8	5.38	1.26	8.76	1.00	7.36
	2032	1 5/8	6.50	1.50	9.94	1.13	10.43
	2033	2 1/8	8.50	2.00	10.63	1.50	16.73
	2034	2 5/8	11.00	2.25	11.94	1.69	28.18
	2035	3 1/8	112.00	2.63	13.25	1.75	44.09

PACKED SHUT-OFF VALVES

Packed, Globe, Back-Seating Design

The function of a Globe Valve is to control flow or provide isolation in liquid or gas applications that may require frequent use.

Applications

Henry Technologies' Packed Valves are used in a variety of air conditioning and refrigeration applications for isolating, flow control, charging and purging. The 926 series Globe Valves are suitable for use with HCFC and HFC refrigerants and their associated oils, as well as other industrial fluids non-corrosive to brass, steel, and synthetic rubber.

Main Features

- Brass construction
- ODS connections
- Compact design
- Backseating stem to allow for replacing stem packing while under pressure

Technical Specifications

Maximum working pressure = 500 PSI (34.5 Bar)

Allowable operating temperature = -20°F to +300°F (-29°C to +149°C)

Henry Technologies' 926 series Packed Globe Valves are designed and registered for use in Canada. Please contact Technical Support at 1-800-627-5148 for CRN details and list of approved provinces and territories.

Materials of Construction

The valve body is made from brass. The stem is made from plated steel. A metal-to-metal seat seal is used. A graphite compound is used for the packing gland. The seal cap is made from molded plastic.

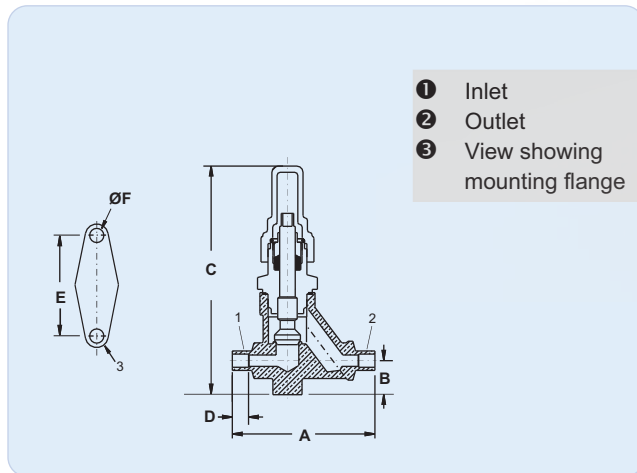

CRN

	Part No	ODS (inch)	Dimensions (inch)					ØF	Weight (lbs)
			A	B	C	D	E		
Backseating	9261	1/4	2.75	0.66	4.41	0.31	1.63	0.28	0.79
	9263	3/8	3.00	0.66	4.41	0.38	1.63	0.28	0.79
	9264	1/2	3.19	0.66	4.41	0.44	1.63	0.28	0.79
	9265	5/8	3.38	0.72	4.47	0.69	1.63	0.28	0.79

RECEIVER VALVES

Packed, Angle, Back-Seating Design

The function of a Receiver Valve is to isolate the inlet and outlet of the Liquid Receiver, or other system component, to allow service or maintenance. Additionally, the Back-Seating design allows the stem packing to be replaced while under pressure.

Applications

Henry Technologies' Receiver Valves are used in a variety of air conditioning and refrigeration applications for isolating, flow control, charging and purging. The 779-B & 783 series Angle Receiver Valves are suitable for use with HCFC and HFC refrigerants and their associated oils, as well as other industrial fluids non-corrosive to brass, steel, and synthetic rubber.

Main Features

779-B series

- Brass construction
- NPT and SAE Flare connections
- Compact design
- Backseating stem to allow for replacing stem packing while under pressure
- Molded plastic seal cap

783 series

- Brass construction
- ODS connections
- Compact design
- 1/4" SAE Flare port
- Backseating stem to allow for replacing stem packing while under pressure
- Molded plastic seal cap



CRN

Technical Specifications

Maximum working pressure = 500 PSI (34.5 Bar)

Allowable operating temperature = -20°F to +300°F (-29°C to +149°C)

Henry Technologies' 779-B and 783 series Packed Receiver Valves are designed and registered for use in Canada. Please contact Technical Support at 1-800-627-5148 for CRN details and list of approved provinces and territories.

Materials of Construction 779-B and 783 series

The valve body is made from brass. The stem is made from plated steel. A metal-to-metal seat seal is used. A graphite compound is used for the packing gland. The seal cap is made from molded plastic.

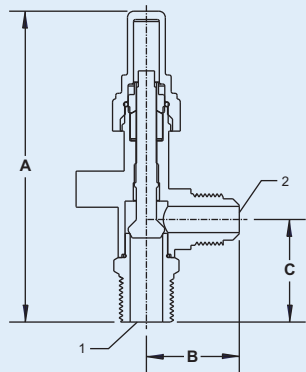

FIG 1

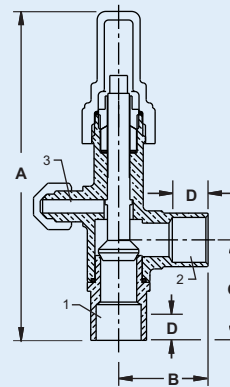

FIG 2

- ❶ Bottom Connection
- ❷ Side Connection
- ❸ 1/4 SAE Flare

	Part No	Fig No	Conn Size (inch)		Dimensions (inch)				Weight (lbs)
			Bottom	Side	A	B	C	D	
Backseating	7792-B	1	1/2 NPTF	1/2 SAE Flare	4.79	1.44	1.59	N/A	0.62
	7793-B	1	1/2 NPTF	5/8 SAE Flare	4.91	1.53	1.69	N/A	0.69
	7830	2	3/8 ODS	3/8 ODS	4.35	1.28	1.16	0.31	0.54
	7831	2	1/2 ODS	1/2 ODS	4.48	1.28	1.28	0.38	0.54
	7832	2	5/8 ODS	5/8 ODS	4.60	1.25	1.41	0.50	0.54
	7833	2	7/8 ODS	7/8 ODS	5.44	1.75	1.69	0.75	1.06
	7834	2	1 1/8 ODS	1 1/8 ODS	7.10	1.75	2.00	0.94	1.83
	7835	2	1 3/8 ODS	1 3/8 ODS	7.42	2.00	2.25	1.00	2.40
	7836	2	1 5/8 ODS	1 5/8 ODS	9.14	2.13	2.44	1.09	3.53

RECEIVER VALVES

Packed, Globe, Non Back-Seating Design

The function of a Receiver Valve is to isolate the inlet and outlet of the Liquid Receiver, or other system component, to allow service or maintenance.

Applications

Henry Technologies' Packed Receiver Valves are used in a variety of air conditioning and refrigeration applications for isolating, flow control, charging and purging. The 927 series Angle Receiver Valves are suitable for use with HCFC and HFC refrigerants and their associated oils, as well as other industrial fluids non-corrosive to brass, steel, and synthetic rubber.

Main Features

- Brass construction
- ODS bottom connections
- SAE flare side connections
- Compact design
- Molded plastic seal cap

Technical Specifications

Maximum working pressure = 700 PSI (48.2 Bar)

Allowable operating temperature = -20°F to +300°F (-29°C to +149°C)

Henry Technologies' 927 Series Receiver Valves are UL and C-UL Listed by Underwriters Laboratories, Inc. Additionally, the valves are designed and registered for use in Canada. Please contact Technical Support at 1-800-627-5148 for CRN details and list of approved provinces and territories.

Materials of Construction

The valve body is made from brass. The stem is made from plated steel. A metal-to-metal seat seal is used. A graphite compound is used for the packing gland. The seal cap is made from molded plastic.

Installation - Notes

1. Valves ship unassembled. Stem and packing must be assembled after brazing ODS connection.
2. Full assembly instructions are given in the Product Instruction Sheet, included with each valve.

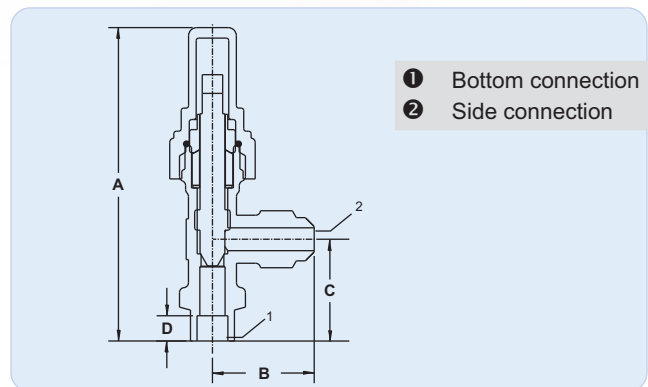

	Part No	Conn Size (inch)		Dimensions (inch)				Weight (lbs)
		Bottom	Side	A	B	C	D	
Non-backseating	9270	1/4 ODS	1/4 SAE Flare	3.85	1.25	1.25	0.31	0.33
	9271	3/8 ODS	1/4 SAE Flare	3.85	1.25	1.25	0.31	0.33
	9272	3/8 ODS	3/8 SAE Flare	3.85	1.25	1.25	0.31	0.46
	9273	1/2 ODS	1/4 SAE Flare	3.85	1.25	1.25	0.38	0.33
	9274	1/2 ODS	3/8 SAE Flare	3.85	1.25	1.25	0.38	0.46

RECEIVER VALVES

Packed, Globe, Non Back-Seating Design

The function of a Receiver Valve is to isolate the inlet and outlet of the Liquid Receiver, or other system component, to allow service or maintenance.

Applications

Henry Technologies' Packed Receiver Valves are used in a variety of air conditioning and refrigeration applications for isolating, flow control, charging and purging. The 776-B and 777-B series Angle Receiver Valves are suitable for use with HCFC and HFC refrigerants and their associated oils, as well as other industrial fluids non-corrosive to brass, steel, and synthetic rubber.

Main Features

- Brass construction
- ODS and NPT bottom connections
- SAE Flare or NPT side connections
- Compact design
- Molded plastic seal cap

Technical Specifications

Maximum working pressure = 500 PSI (34.5 Bar)

Allowable operating temperature = -20°F to +300°F (-29°C to +149°C)

Henry Technologies' Packed Receiver Valves are designed and registered for use in Canada. Please contact Technical Support at 1-800-627-5148 for CRN details and list of approved provinces and territories.

Materials of Construction

The valve body is made from brass. The stem is made from plated steel. A metal-to-metal seat seal is used. A graphite compound is used for the packing gland. The seal cap is made from molded plastic.



CRN

- 1 Bottom Connection
- 2 Side Connection

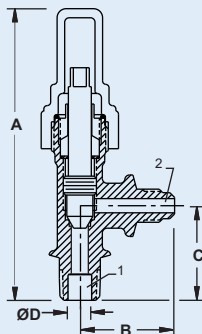

FIG 1

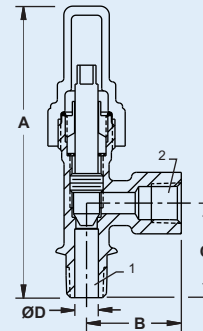

FIG 2

	Part No	Fig No	Conn Size (inch)		Dimensions (inch)				Weight (lbs)
			Bottom	Side	A	B	C	ØD	
Non-backseating	7761-B	1	1/4 NPTF / 1/4 ODS	1/4 SAE Flare	3.85	1.25	1.25	0.31	0.35
	7771-B	2	1/4 NPTF / 5/16 ODS	1/4 NPTF	3.85	1.25	1.25	0.31	0.35
	7763-B	1	1/4 NPTF / 5/16 ODS	3/8 SAE Flare	3.85	1.25	1.25	0.31	0.35
	7764-B	1	3/8 NPTF / 3/8 ODS	1/4 SAE Flare	3.85	1.25	1.25	0.31	0.35
	7766-B	1	3/8 NPTF / 3/8 ODS	3/8 SAE Flare	3.85	1.25	1.25	0.31	0.35
	7767-B	1	3/8 NPTF / 3/8 ODS	1/2 SAE Flare	3.85	1.25	1.25	0.31	0.40
	7768-AB	1	1/2 NPTF / 1/2 ODS	3/8 SAE Flare	3.88	1.31	1.38	0.38	0.59
	7768-B	1	1/2 NPTF / 1/2 ODS	5/8 SAE Flare	3.88	1.63	1.38	0.38	0.91

SWIVEL VALVES

Angle Type

The function of a Swivel Valve is to provide a point of isolation for servicing within a refrigeration or oil circuit.

Applications

This valve type mounts to a male flare by means of a swivel nut. The valve can be orientated in any direction for easy connection. Henry Technologies' Swivel Valves are suitable for use with HCFC and HFC refrigerants and their associated oils, as well as other industrial fluids non-corrosive to brass, copper and synthetic rubber.

Main Features

- Swivel base connection allows for 360° swivel of side flare connection
- SAE flare connections
- Seal cap design

Technical Specifications

Maximum allowable working pressure = 500 PSI (34.5 Bar)

Allowable operating temperature = -20°F to +300°F (-29°C to +149°C)

Materials of Construction

The valve body is made from forged brass. The stem is made from plated steel. The cap is made from molded plastic. The swivel flare is brass and the inlet swivel tube is copper.

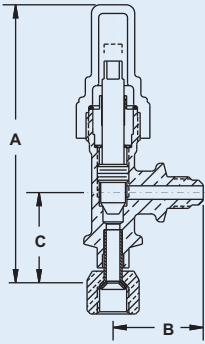

Part No	Conn Size (inch)		Dimensions (inch)			Weight (lbs)
	Side	Bottom	A	B	C	
9240	1/4 SAE Male Flare	1/4 SAE Female Flare	3.85	1.25	1.25	0.30
9241	3/8 SAE Male Flare	3/8 SAE Female Flare	3.85	1.25	1.25	0.44

SHUT-OFF VALVES

Forged Steel, Non Back-Seating Design

The function of a Forged Steel Shut-Off valve is to provide an isolation or connection point in liquid and gas applications where brass valves are not compatible or do not meet the pressure requirements.

Applications

Henry Technologies' Shut-Off Valves are used in a variety of air conditioning and refrigeration applications for isolating, flow control, charging and purging. The 776 and 777 series Shut-Off Valves are suitable for use with ammonia, HCFC and HFC refrigerants and their associated oils, as well as other industrial fluids non-corrosive to steel and synthetic rubber.

Main Features

- Forged steel construction
- NPT bottom connections
- SAE Flare and NPT side connections
- Compact design
- Molded plastic seal cap

Technical Specifications

Maximum working pressure = 1000 PSI (68.9 Bar)

Allowable operating temperature = -20°F to +300°F (-29°C to +149°C)

Materials of Construction

The valve body is made from forged steel. The stem is made from plated steel. A metal-to-metal seat seal is used. A graphite compound is used for the packing gland. The seal cap is made from molded plastic.

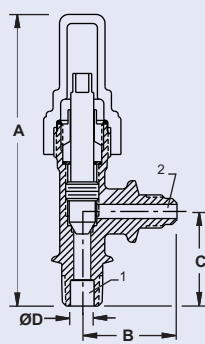

FIG 1

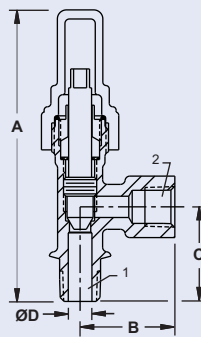

FIG 2

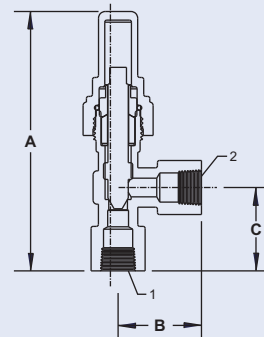

FIG 3

- ❶ Bottom Connection
- ❷ Side Connection

	Part No	Figure No	Conn Size (inch)		Dimensions (inch)				Weight (lbs)
			Bottom	Side	A	B	C	Ø D	
Non-backseating	7761	1	1/4 NPTF	1/4 SAE Flare	3.85	1.25	1.25	0.31	0.31
	7771	2	1/4 NPTF	1/4 NPTF	3.85	1.25	1.25	0.31	0.33
	7771E	2	1/4 NPTF	1/4 NPTF	7.48	1.25	4.88	0.31	0.36
	7772	3	1/4 NPTF	1/4 NPTF	3.85	1.25	1.25	N/A	0.33
	7773	2	3/8 NPTF	3/8 NPTF	4.29	1.50	1.73	0.41	0.84
	7774	3	3/8 NPTF	1/2 NPTF	4.29	1.50	1.73	N/A	0.84
	7775	2	1/2 NPTF	1/2 NPTF	4.29	1.50	1.73	0.47	0.86

INDUSTRIAL SHUT-OFF VALVES

Screw-End Threaded Valve

The main functions of the Shut-Off Valve are to start or stop fluid within the particular circuit it is installed.

Applications

The Henry Technologies' range of Globe and Angle Shut-Off Valves is used for isolation purposes, primarily within ammonia refrigeration systems. The threaded end series are a lower cost option to manually control flow in a pipe. Henry Technologies' Shut-Off Valves are suitable for use with ammonia, HCFC and HFC refrigerants and their associated oils, as well as other industrial fluids non-corrosive to ductile iron, steel, Teflon and synthetic rubber.

Main Features

- Non-rotating self aligning swivel seat disc with fully retained Teflon seat ring
- Lower cost than flanged designs
- Backseating stem to allow for replacing stem packing while under pressure
- Protective painted finish
- Valve bonnets threaded to accept Henry Seal Cap

Technical Specifications

Maximum cold working pressure = 400 PSI (27.6 Bar)

Allowable operating temperature = -20°F to +275°F (-29°C to +135°C)

Materials of Construction

The valve body is made from ductile iron. The valve bonnet is made from ductile iron. The seal caps are molded plastic. The stem is made from stainless steel and is adaptive for hand-wheel mounting.

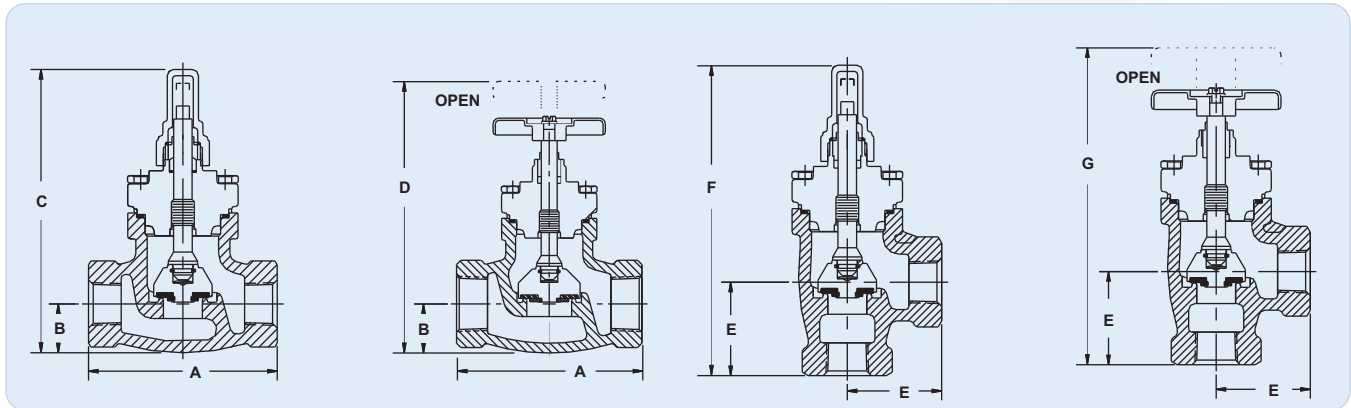

FPT (inch)	Part No				Dimensions (inch)								Weight (lbs)	
	Globe Seal Cap	Angle Seal Cap	Globe Hand Wheel	Angle Hand Wheel	A	B	C	D	E	F	G	Globe	Angle	
3/8	N/A	N/A	310G	N/A	3.63	0.94	N/A	5.44	N/A	N/A	N/A	2.0	N/A	
1/2	C320G	C370G	320G	370G	3.63	0.94	5.46	5.44	1.81	5.94	5.97	2.5	2.0	
3/4	C330G	C380G	330G	380G	3.63	0.94	5.46	5.44	1.81	5.94	5.97	2.5	2.0	
1	C340G	C390G	340G	390G	4.13	1.09	5.76	5.74	1.81	6.02	6.05	3.5	2.5	

PACKLESS VALVES

Golden Bantam Series

The function of a Packless Valve is to control flow or provide isolation in liquid or gas applications. Packless Valves are also suitable for use in vacuum applications.

Applications

Henry Technologies' Packless Valves are used in a variety of air conditioning and refrigeration applications for isolating, flow control, charging and purging purposes. The Golden Bantam Series Packless Valves are suitable for use with HCFC and HFC refrigerants, and their associated oils, as well as other industrial fluids non-corrosive to brass, phosphor bronze, copper, stainless steel and nylon.

Main Features

- Robust Design
- Compact
- Heat stabilized nylon seat ring for positive shut-off
- Positive back-seating with valve in open position
- Raised seat reduces debris induced sealing issues
- Large diameter diaphragm for greater lift, better flow and longer life
- Hermetic seal between bonnet, diaphragms and body
- Suitable for vacuum applications

Technical Specifications

Maximum working pressure = 500 PSI (34.5 Bar)

Allowable operating temperature = -20°F to +275°F (-29°C to +135°C)

Henry Technologies' Golden Bantam Series Packless Valves are UL and C-UL Listed by Underwriters Laboratories, Inc.



Materials of Construction

The valve body, upper stem and bonnet are made from brass. The lower stem/seat ring is made from nylon and the diaphragm set is composed of both phosphor bronze and stainless steel. The valve spring is made from stainless steel. The hand-wheel is made from die cast zinc.

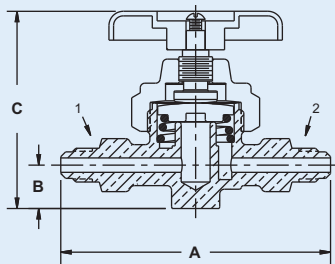

FIG 1

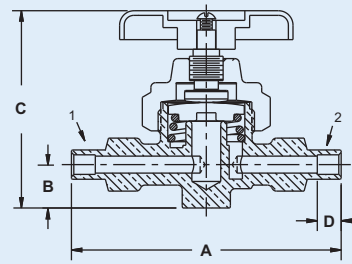
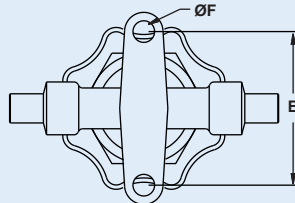

FIG 2

- ① Inlet
- ② Outlet

Golden Bantam Valves

Part No	Fig No	Conn Size (inch)	Dimensions (inch)						Weight (lbs)	Cv
			A	B	C (Open)	D	E	Ø F		
5151	1	1/4 SAE Flare	3.50	0.56	2.56	N/A	2.00	0.28	0.62	0.45
5153	1	3/8 SAE Flare	3.50	0.56	2.56	N/A	2.00	0.28	0.64	0.86
5161	2	1/4 ODS	3.50	0.56	2.56	0.31	2.00	0.28	0.64	0.66
5163	2	3/8 ODS	3.50	0.56	2.56	0.31	2.00	0.28	0.64	0.88
5164	2	1/2 ODS	3.88	0.62	2.94	0.38	2.00	0.28	0.99	1.49
5165	2	5/8 ODS	4.13	0.75	3.00	0.56	2.00	0.28	1.12	2.56

PACKLESS VALVES

Standard Series

The function of a Packless Valve is to control flow or provide isolation in liquid or gas applications. Packless Valves are also suitable for use in vacuum applications.

Applications

Henry Technologies' Packless Valves are used in a variety of air conditioning and refrigeration applications for isolating, flow control, charging and purging purposes. The standard series Packless Valves are suitable for use with HCFC and HFC refrigerants, and their associated oils, as well as other industrial fluids non-corrosive to brass, phosphor bronze, copper, stainless steel, nylon and monel.

Main Features

- Robust Design
- Compact
- Heat stabilized nylon seat ring for positive shut-off
- Positive back-seating with valve in open position
- Raised seat reduces debris induced sealing issues
- Large diameter diaphragm for greater lift, better flow and longer life
- Hermetic seal between bonnet, diaphragms and body
- Suitable for vacuum applications
- Diaphragms are changeable under line pressure
- Bi-directional flow (see additional information)

Technical Specifications

Maximum working pressure = 500 PSI (34.5 Bar)

Allowable working temperature = -20°F to +275°F (-29°C to +135°C)

The standard series globe and angle Packless Valves are designed in conformance with MIL-V-20064E and Military Standards MS-35880, MS-35881 and MS-35883.

Materials of Construction - Standard series

The valve body and bonnet are made from brass. The lower stem is made from brass for all models except the 629 series, where the material is monel. The upper stem, stem cap and valve springs are made from stainless steel. The seat ring is made from nylon for all models except the 629 series. These models use a stainless steel seat ring. The diaphragm set is composed of both phosphor bronze and stainless steel. The hand-wheel is made from die cast zinc.

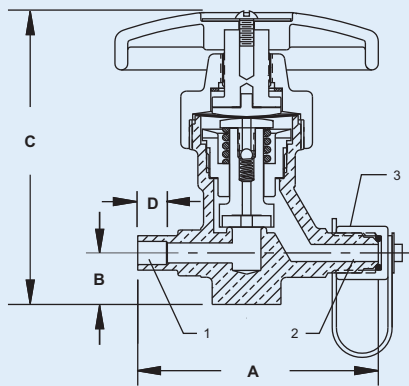
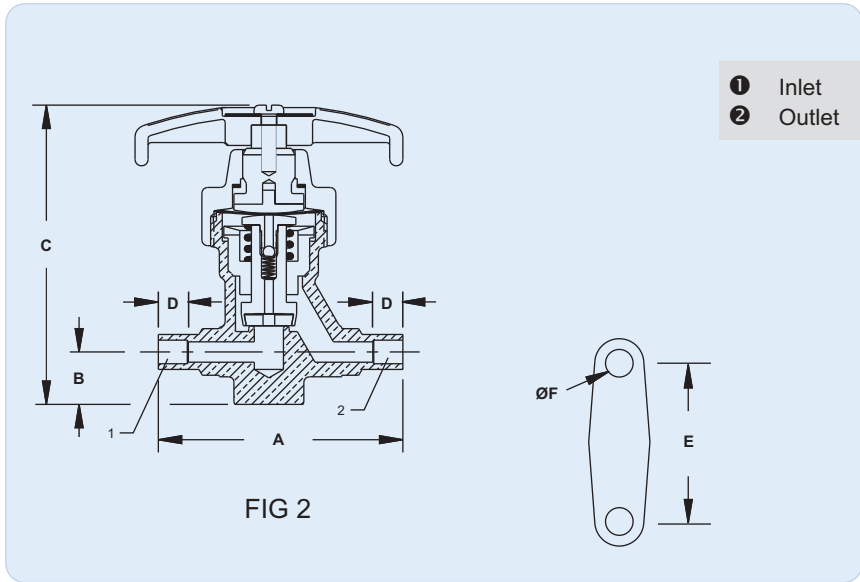

FIG 1

- 1 Inlet ODS Connection
- 2 Outlet SAE Flare Connection
- 3 Integral Seal Cap
- 4 Mounting Flange Detail

Part No	Fig No	Conn Size (inch)	Dimensions (inch)						Weight (lbs)
			A	B	C	D	E	Ø F	
6231N	1	1/4 ODS x 1/4 SAE Flare	2.63	0.56	3.38	0.31	1.63	0.27	1.04
6232N	1	3/8 ODS x 3/8 SAE Flare	2.63	0.56	3.38	0.44	1.63	0.27	1.21
6233N	1	1/2 ODS x 1/2 SAE Flare	3.25	0.63	3.56	0.56	1.75	0.28	1.37
6234N	1	5/8 ODS x 5/8 SAE Flare	5.79	1.18	3.75	1.08	3.14	0.44	1.43



Part No	Fig No	ODS (inch)	Dimensions (inch)						Weight (lbs)	Cv
			A	B	C	D	E	Ø F		
6261N	2	1/4	2.63	0.56	3.38	0.31	1.63	0.27	1.04	0.69
6263N	2	3/8	2.63	0.55	3.38	0.44	1.63	0.27	1.12	0.78
6264N	2	1/2	3.13	0.63	3.56	0.56	1.75	0.28	1.26	1.44
6265N	2	5/8	3.50	0.69	3.75	0.69	2.00	0.28	1.43	2.48
6266N	2	3/4	4.38	0.71	5.00	0.75	2.25	0.34	3.13	3.70
6267N	2	7/8	4.81	0.75	5.38	0.88	2.50	0.41	3.53	5.31
6268N	2	1 1/8	5.94	0.94	6.50	1.00	3.25	0.41	5.80	8.41

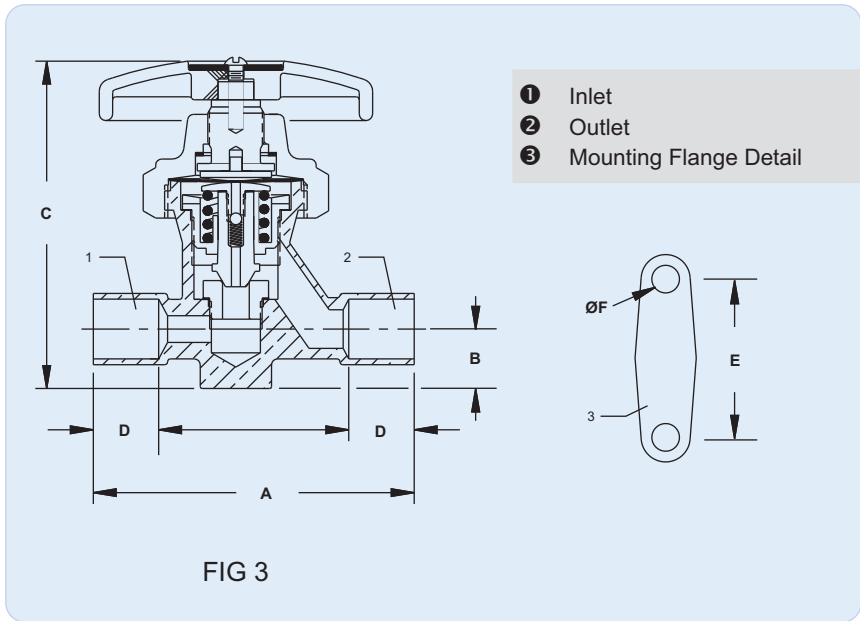

HAND EXPANSION/THROTTLING DATA						
Cv (turns open)						
.25	.50	.75	1.00	1.25	1.50*	
0.123	0.209	0.325	0.401	0.457	0.496	
0.173	0.310	0.395	0.475	0.504	0.518	
0.098	0.263	0.354	0.388	0.475	0.497	
0.232	0.389	0.581	0.663	0.786	0.860	
0.317	0.546	0.877	1.036	1.189	1.428	
0.896	1.355	1.648	2.247	2.274	2.554	

*Full Open

Part No	Fig No	ODS (inch)	Dimensions (inch)						Weight (lbs)
			A	B	C	D	E	Ø F	
6291N	3	1/4	2.63	0.56	3.38	0.31	1.63	0.27	1.04
6293N	3	3/8	2.63	0.56	3.38	0.44	1.63	0.27	1.04
6294N	3	1/2	2.63	0.56	3.38	0.56	1.63	0.27	1.04
6295N	3	5/8	3.38	0.63	3.56	0.69	1.75	0.28	1.28
6297N	3	7/8	4.49	0.69	5.00	0.75	2.25	0.34	2.76
6298N	3	1 1/8	4.81	0.75	5.38	0.81	2.50	0.41	3.26

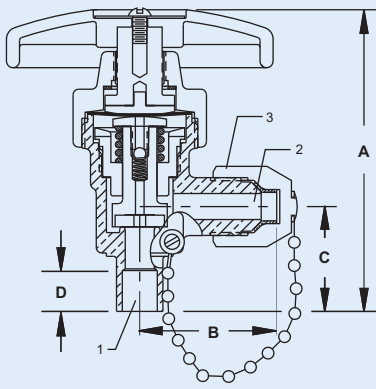

- ❶ Bottom ODS Connection
- ❷ Side SAE Flare Connection
- ❸ Integral Seal Cap

FIG 4

Part No	Fig No	Conn Size (inch)	Dimensions (inch)				Weight (lbs)
			A	B	C	D	
6432N	4	3/8 ODS x 3/8 SAE Flare	3.39	1.31	1.13	0.44	0.97
6433N	4	1/2 ODS x 1/2 SAE Flare	3.50	1.63	1.19	0.56	1.32
6434N	4	5/8 ODS x 5/8 SAE Flare	3.82	1.75	1.38	0.69	1.76

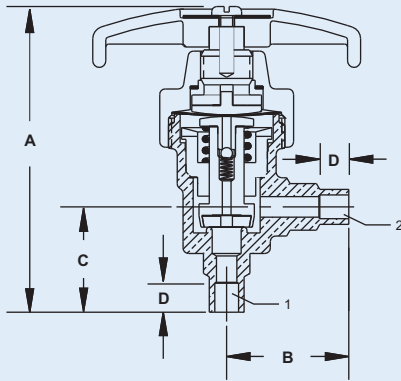

- ❶ Bottom Connection
- ❷ Side Connection

FIG 5

Part No	Fig No	ODS (inch)	Dimensions (inch)				Cv	Weight (lbs)
			A	B	C	D		
6471N	5	1/4	3.44	1.31	1.13	0.31	0.86	
6473N	5	3/8	3.44	1.31	1.13	0.44	0.88	
6474N	5	1/2	3.50	1.50	1.19	0.56	2.21	
6475N	5	5/8	3.81	1.50	1.38	0.69	4.11	
6476N	5	3/4	4.88	1.88	1.41	0.75	6.55	
6477N	5	7/8	5.38	2.09	1.78	0.88	8.54	
6478N	5	1 1/8	6.50	2.50	2.25	1.00	11.06	

Additional Information

1. For series 623*, 626*, 643* and 647*: Valves are bi-directional up to 350 PSI (24.1 Bar). Above this pressure, the direction of flow should be with the inlet under the valve seat.
2. For series 629*: For hand expansion or throttling service, the direction of flow should be with the inlet under the valve seat.
3. All Cv Values are based on flow inlet under the valve seat.

Installation - Notes

1. Valves must be protected against excessive heat when installing to prevent damage to the seals. Full instructions are given in the Product Instruction Sheet, included with each valve.

ROTALOCK VALVES

The function of a Rotalock Valve is to provide a convenient removable access and isolation point for service.

Applications

Rotalock Valves are widely used throughout the refrigeration and air-conditioning industry and are typically installed on Compressors and Pressure Vessels. Henry Technologies' Rotalock Valves are suitable for use with HCFC and HFC refrigerants and their associated oils, as well as other industrial fluids non-corrosive to steel, copper and Teflon.

Main Features

- Industry standard Rotalock thread sizes
- ODS and SAE flare connections
- 1/4" SAE Flare access ports
- Minimal pressure drop
- Removable
- Bi-directional flow
- Seal cap design

Technical Specifications

Maximum working pressure = 500 PSI (34.5 Bar)

Allowable operating temperature = -20°F to +250°F (-29°C to +121°C)

Materials of Construction

The valve and connections are made from plated steel. The connection gasket is made from Teflon. The seal caps are made of plated steel and use a copper gasket.

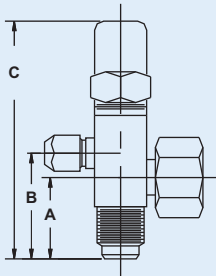

FIG 1

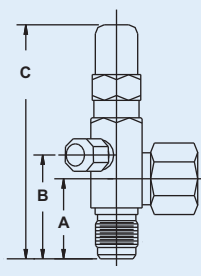

FIG 2

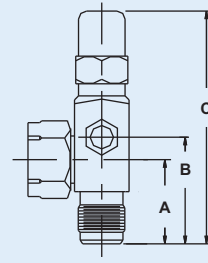

FIG 3

FLARE CONNECTIONS

Part No (with gasket)	Fig No	SAE Flare (inch)	Rotalock Thread Size (inch)	Dimensions (inch)		
				A	B	C
3-030-131	2	1/4	3/4 -16	1.17	1.52	3.42
3-030-122	1	3/8	3/4 -16	1.17	1.52	3.42
3-030-123	2	3/8	3/4 -16	1.17	1.52	3.72
3-030-130	2	3/8	3/4 -16	1.17	1.52	3.42
3-030-108	1	1/2	1 - 14	1.30	1.72	3.75
3-030-135	3	1/2	1 - 14	1.30	1.72	3.75
3-030-112	1	5/8	1 - 14	1.55	1.97	4.00

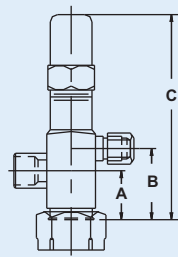

FIG 4

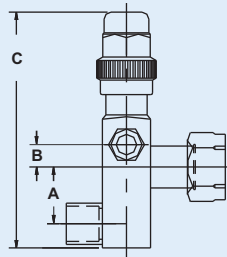

FIG 5

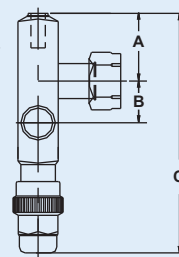

FIG 6

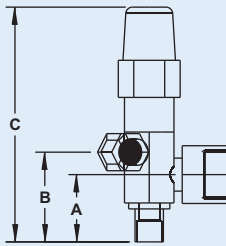

FIG 7

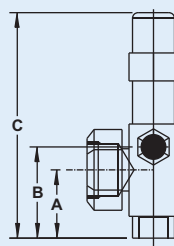

FIG 8

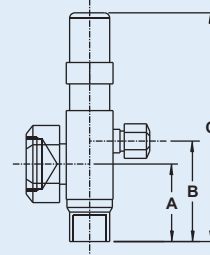

FIG 9

ODS CONNECTIONS

Part No (with gasket)	Fig No	ODS (inch)	Rotalock Thread Size (inch)	Dimensions (inch)		
				A	B	C
3-030-139	7	3/8	3/4 - 16	1.02	1.36	3.56
3-030-133	8	1/2	1 - 14	1.22	1.63	4.06
3-030-140	4	1/2	1 - 14	0.88	1.28	3.69
3-030-127	9	5/8	1 - 14	1.45	1.88	4.28
3-030-150	4	5/8	1 - 14	0.85	1.27	3.63
3-030-152	9	5/8	1 - 14	1.45	1.88	4.36
3-030-163	5	5/8	1 - 14	1.03	0.41	4.28
3-030-164	5	5/8	1 - 14	2.64	0.41	5.89
3-030-167	6	5/8	1 - 14	1.47	2.38	5.20
3-030-186	9	5/8	1 1/4 - 12	1.67	2.34	5.05
3-030-136	9	7/8	1 1/4 - 12	1.69	2.34	5.38
3-030-141	4	7/8	1 1/4 - 12	1.08	1.74	4.77
3-030-142	4	1 1/8	1 1/4 - 12	1.09	1.75	4.78
3-030-143	4	1 3/8	1 3/4 - 12	1.47	2.31	6.19
3-030-160	7	1 3/8	1 3/4 - 12	2.82	3.26	7.16
3-030-162	7	1 5/8	1 3/4 - 12	2.47	3.31	7.16

REPLACEMENT GASKET

Part No	Rotalock Thread Size (inch)
2-023-018	3/4 - 16
2-023-013	1 - 14
2-023-015	1 1/4 - 12
2-023-016	1 3/4 - 12

ROTALOCK ADAPTERS

The function of a Rotalock Adapter is to provide a convenient removable piping connection to system components.

Applications

Rotalock Adapters are used to connect piping to compressors, pressure vessels and other components when an access or isolation point is unneeded. Henry Technologies' Rotalock Adapters are suitable for use with HCFC and HFC refrigerants and their associated oils, as well as other industrial fluids non-corrosive to steel, and Teflon.

Main Features

- Industry standard Rotalock thread sizes
- ODS connections
- Straight-thru and angle designs
- Removable

Technical Specifications

Maximum working pressure = 500 PSI (34.5 Bar)

Allowable operating temperature = -20°F to +250°F (-29°C to +121°C)

Materials of Construction

The adapter body and connections are made from plated steel. The connection gasket is made of Teflon.

Part No	Part No (with gasket)	Connection Size (inch)	Rotalock Thread Size (inch)	Description
2-030-153	N/A	3/8 ODS	3/4 - 16 Female	Straight thru adapter
2-030-159	3-030-001	1 - 14 Male Rotalock	3/4 - 16 Female	Straight thru adapter
2-030-171	3-030-002	3/4 - 16 Male Rotalock	1 - 14 Female	Straight thru adapter
2-030-166	N/A	5/8 ODS	1 - 14 Female	Straight thru adapter
2-030-128	N/A	5/8 ODS	1 - 14 Female	Angle adapter
2-030-137	N/A	7/8 ODS	1 1/4 - 12 Female	Angle adapter

REPLACEMENT GASKET	
Part No	Rotalock Thread Size (inch)
2-023-018	3/4 - 16
2-023-013	1 - 14
2-023-015	1 1/4 - 12
2-023-016	1 3/4 - 12

BY-PASS VALVES

The function of a By-Pass Valve is to handle momentary instances of over pressure (not due to fire) to prevent Pressure Relief Valve discharge.

Applications

The Henry Technologies' 5467 By-Pass Valve is positioned between the pressure vessel and the Three-Way Valve before the Pressure Relief Valve as shown in Figure 2 below. In the event of a high pressure spike, the valve bypasses excess pressure to the low side of the system thus preventing the Pressure Relief Valve from discharging refrigerant into the atmosphere. If the over pressure increases then the Pressure Relief Valve will be activated.

The valve is designed to bypass only enough gas to reduce the effects of high pressure spikes. The valve has relatively low flow rates, thus high flow rates would adversely affect system performance. Continuous bypassing of refrigerant for extended periods of time can lead to loss of system capacity, excessively high compressor temperatures, and possible compressor failure. We recommend a sensor be put in the By-Pass Valve discharge line to monitor if the valve is relieving from high to low side. All By-Pass Valves are suitable for use with HFC and HCFC refrigerants and their associated oils, as well as other industrial fluids non-corrosive to brass, steel, copper and Teflon.

Main Features

- Brass construction
- Extended ODS connections
- Positive pressure relief during high pressure spikes
- Consistent operation and reseating
- Flow direction arrow

Technical Specifications

Set pressure range: 150 to 450 PSI

Standard set pressures: 250, 290, 330, 350 and 375 PSI

Allowable operating temperature: -20°F to +200°F (-29°C to +93°C)

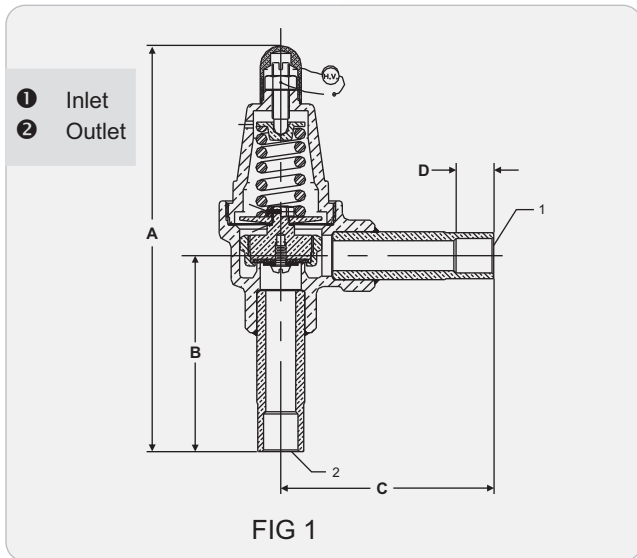

Selection Guidelines

Henry Technologies By-Pass Valves are to be set approximately 80-85% of relief valve setting. See the Relief Valve Selection Guidelines located in this catalog for more information.

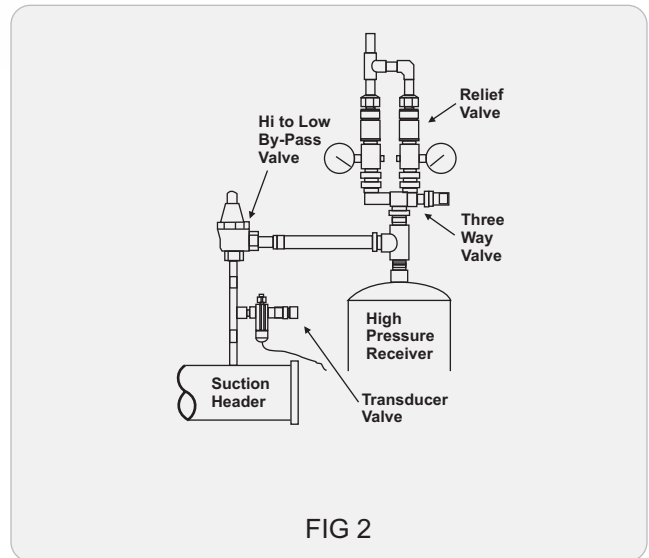

Part No	By-Pass Valve Setting (PSI)	Capacity (#Air/Min)	Relief Valve Setting (PSI)	ODS (Inch)	Dimensions (inch)				Weight (lbs)
					A	B	C	D	
5467-250	250	3.5	300	5/8	7.43	3.60	3.88	0.69	2.60
5467-290	290	4.0	350	5/8	7.43	3.60	3.88	0.69	2.60
5467-330	330	4.5	400	5/8	7.43	3.60	3.88	0.69	2.60
5467-350	350	4.8	425	5/8	7.43	3.60	3.88	0.69	2.60
5467-375	375	5.1	450	5/8	7.43	3.60	3.88	0.69	2.60

PRESSURE RELIEF VALVES

The main function of a Pressure Relief Valve is to protect against accidental over-pressure of a pressure vessel due to system malfunction or fire.

Applications

Henry Technologies' Relief Valves are designed to be used in refrigeration systems to prevent over-pressure due to system malfunction or excessive external heat. They are to be used only with refrigerant vapor or gas, where they are typically installed on the top section of a pressure vessel, i.e. liquid receiver or suction accumulator.

Most states and municipalities which have refrigeration safety codes conform to the "American Standard Safety Code for Mechanical Refrigeration (ANSI/ASHRAE 15)". This code and ASME states that the Relief Valve setting is not to exceed the design working pressure of the vessel on which the Relief Valve is installed. The discharge capacity of relief valves varies with pressure setting. The discharge capacity required is based on the size of the vessel and the refrigerant used. See "Determining Minimum Required Discharge Capacity" section for more information, or contact Technical Support at 1-800-627-5148.

Whenever conditions permit, it is highly advisable to have the Relief Valve pressure setting (which must not exceed the design working pressure of the vessel) at least 25% higher than the normal operating pressure for the refrigerant used.

52 series Pressure Relief Valves are suitable for use with HCFC and HFC refrigerants and their associated oils, as well as other industrial fluids non-corrosive to brass, steel and Teflon.

53 and 56 series Pressure Relief Valves are suitable for use with ammonia, HCFC and HFC refrigerants and their associated oils, as well as other industrial fluids non-corrosive to steel, iron and Teflon.

How it works

All Henry Technology Relief Valves are 100% tested and manufactured to guidelines as indicated in ASME Section VIII Division I. Every Relief Valve is calibrated to indicate a pre-determined set pressure, where the valve begins to allow gas or vapor to pass through. The valve will open to a full discharge within 10% over set pressure. After discharge Pressure Relief Valves will blow down and reset once the pressure falls below the valves set pressure.

Main Features

- NPT and SAE flare connections
- High pressure line available (500-675 PSI) suitable for R410A & CO₂. See model numbers 5233AX, 5234AX and 5235AX
- Valves fully open before 10% overpressure when taken from the average set pressure
- Reset pressure ranges typically 10-40% (blowdown) from pop pressure
- Valves bear individual serial numbers
- UV-1 pressure test reports available upon request

Technical Specifications

All Henry Technologies PRV's have a set pressure range +/- 3% of the stamped pressure.

Set pressure range = see tables

Allowable operating temperature = -20°F to +225°F (-29°C to +107°C)

Henry Technologies' Relief Valves are stamped with the ASME UV symbol and NB to indicate National Board certification as to capacities. Additionally, Pressure Relief Valves are designed and registered for use in Canada. Please contact Technical Support at 1-800-627-5148 for CRN details and list of approved provinces and territories.

Materials of Construction

The 52 series Relief Valves have brass valve bodies. The internal parts are made of brass and carbon steel. The 53 series valves have stainless steel valve bodies. Internal parts are made from stainless steel and carbon steel. The 56 series valves have cast or ductile iron valve bodies. The internal parts are made from stainless steel and carbon steel. All valves have Teflon valve seats.



Relief Valve Capacity Ratings

Henry Technology Relief Valves are marked with a discharge capacity in unit lbs-air/min, and marked in accordance with the requirements of the ASME (Boiler and Pressure Vessel Code Section VIII, Division 1). These valves are also approved by many local refrigeration and air conditioning codes in the USA and Canada for relief of excess pressure.

Angle Relief Valve - Brass							
Part No	Fig No	Conn Size (inch)		Dimensions (inch)		Orifice Diameter (inch)	Weight (lbs)
		Inlet	Outlet	A	B		
526E-XXX	1	3/8 MPT	3/8 SAE Flare	2.99	1.41	0.250	0.40

Angle Relief Valve - Steel							
Part No	Fig No	Conn Size (inch)		Dimensions (inch)		Orifice Diameter (inch)	Weight (lbs)
		Inlet	Outlet	A	B		
5600-XXX	2	1/2 FPT	3/4 FPT	2.69	1.63	0.703	3.60
5601-XXX	2	1/2 FPT	1 FPT	2.69	1.63	0.703	3.44
5602-XXX	2	3/4 FPT	1 FPT	2.69	1.63	0.921	3.40
5603-XXX	2	1 FPT	1 1/4 FPT	2.88	2.00	1.000	4.75
5604-XXX	2	1 1/4 FPT	1 1/2 FPT	4.13	2.31	1.125	6.50

Straight-through Relief Valves - Brass							
Part No	Fig No	Conn Size (inch)		Dimensions (inch)	Orifice Diameter (inch)	Weight (lbs)	
		Inlet	Outlet	A			
5230-XXX	3	1/4 MPT	3/8 SAE Flare	3.16	0.250	0.38	
5231-XXX	3	3/8 MPT	3/8 SAE Flare	3.16	0.250	0.39	
5250A-1/2-XXX	4	1/2 MPT	1/2 FPT	4.26	0.375	0.85	
5250-1/2-XXX	4	1/2 MPT	3/4 FPT	4.04	0.375	0.97	
5252-3/4-XXX	4	3/4 MPT	3/4 FPT	4.05	0.375	0.95	
5244-3/4-XXX	4	3/4 MPT	1 FPT	4.16	0.500	1.46	
5244-1-XXX	4	1 MPT	1 FPT	4.16	0.500	1.46	
5246A-1-XXX	4	1 MPT	1 1/4 FPT	5.82	0.719	2.50	
5246A-1-1/4-XXX	4	1 1/4 MPT	1 1/4 FPT	5.82	0.719	2.60	
5233AX-XXX	3	3/8 NPT	7/8 SAE Flare	4.18	0.276	1.02	
5234AX-XXX	4	3/8 NPT	3/4 FPT	4.22	0.276	1.12	
5235AX-XXX	4	1/2 NPT	3/4 FPT	4.50	0.276	1.21	

Straight-through Relief Valves - Stainless Steel							
Part No	Fig No	Conn Size (inch)		Dimensions (inch)	Orifice Diameter (inch)	Weight (lbs)	
		Inlet	Outlet	A			
5350-1/2-XXX	4	1/2 MPT	3/4 FPT	4.00	0.375	0.95	
5352-3/4-XXX	4	3/4 MPT	3/4 FPT	4.00	0.375	1.03	
5344-3/4-XXX	4	3/4 MPT	1 FPT	4.18	0.500	1.46	
5344-1-XXX	4	1 MPT	1 FPT	4.19	0.500	1.46	
5345A-XXX	4	1 MPT	1 1/4 FPT	5.81	0.719	2.50	
5346A-1-1/4-XXX	4	1 1/4 MPT	1 1/4 FPT	5.81	0.719	2.60	

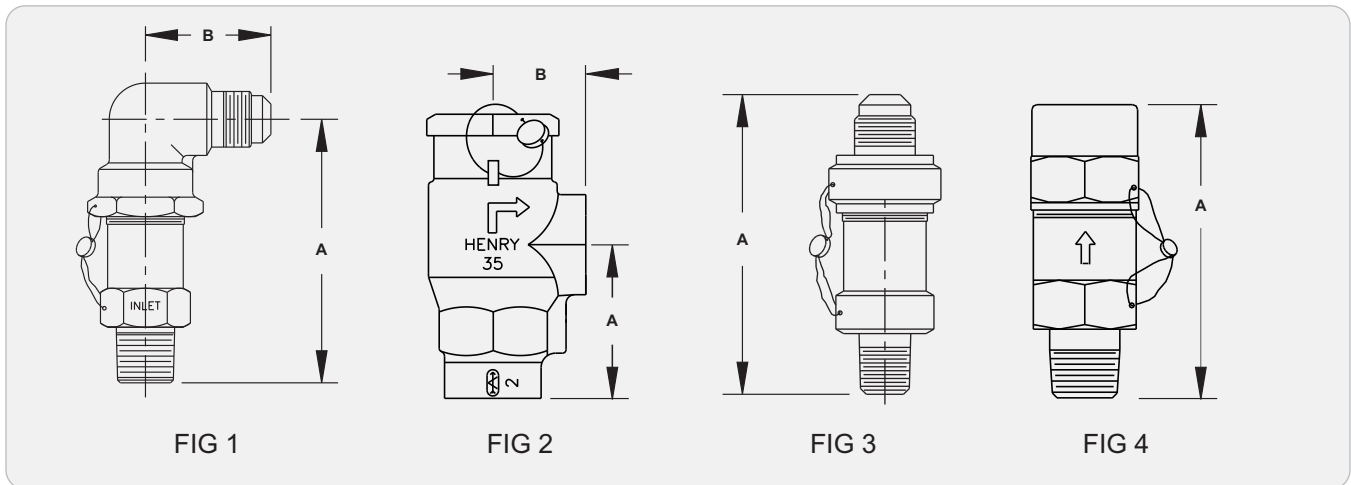

Order Information

- To order, add desired pressure setting to Pressure Relief Valve part number suffix (i.e. 5230-300)
- Pressure certificates (ASME UV-1) are available with each order for an extra charge. Specify a "-C" suffix on the part number.
- Pressure settings outside the range stated for each model are not available. Henry only supplies relief valves bearing the NV-NB stamps.

Part No	Certified Pressure Range (PSI)	Valve Capacity Ratings (lbs. Air/min) for Brass						
		Standard Pressure Setting (PSI)						
		150	235	300	350	400	450	500
5230	150-450	5.0	7.6	9.6	11.2	12.7	14.3	N/A
5231	150-450	5.0	7.6	9.6	11.2	12.7	14.3	N/A
526E	150-450	5.0	7.6	9.6	11.2	12.7	14.3	N/A
5250A-1/2	200-500	N/A	29.0	36.5	42.4	48.2	54.0	59.9
5250-1/2	200-500	N/A	29.0	36.5	42.4	48.2	54.0	59.9
5252-3/4	200-500	N/A	29.0	36.5	42.4	48.2	54.0	59.9
*5350-1/2	200-500	N/A	29.0	36.5	42.4	48.2	54.0	59.9
*5352-3/4	200-500	N/A	29.0	36.5	42.4	48.2	54.0	59.9
5244-3/4	150-450	33.2	50.5	63.8	73.9	84.1	94.3	N/A
5244-1	150-450	33.2	50.5	63.8	73.9	84.1	94.3	N/A
*5344-3/4	150-450	33.2	50.5	63.8	73.9	84.1	94.3	N/A
*5344-1	150-450	33.2	50.5	63.8	73.9	84.1	94.3	N/A
5246A-1	150-400	70.5	107.2	135.2	156.8	178.4	N/A	N/A
5246A-1-1/4	150-400	70.5	107.2	135.2	156.8	178.4	N/A	N/A
*5345A	150-400	70.5	107.2	135.2	156.8	178.4	N/A	N/A
*5346A-1-1/4	150-400	70.5	107.2	135.2	156.8	178.4	N/A	N/A

Part No	Certified Pressure Range (PSI)	Valve Capacity Ratings (lbs. Air/min) for High Pressure Brass				
		Standard Pressure Setting (PSI)				
		500	550	600	650	675
5233AX	500-675	36.0	39.5	43.0	46.5	48.2
5234AX	500-675	36.0	39.5	43.0	46.5	48.2
5235AX	500-675	36.0	39.5	43.0	46.5	48.2

Part No	Certified Pressure Range (PSI)	Valve Capacity Ratings (lbs. Air/min) for Steel (Stainless and Cast)		
		Standard Pressure Setting (PSI)		
		150	250	300
5600	150-450	30.9	49.9	59.4
5601	150-450	35.8	57.7	68.7
5602	150-450	35.8	57.7	68.7
5603	150-450	37.5	60.4	71.9
5604	150-450	72.0	116.1	138.1

Determining Minimum Required Discharge Capacity

ASHRAE has a guideline to determine the minimum required discharge capacity for refrigeration relief valves. Reference ASHRAE 15-2001 Section 9.7.5. Use the following equation and refrigerant factors given to determine the minimum required capacity.

C = Min. Required Capacity (lbs-air/min)

D = Outside Diameter of Vessel, ft

L = Length of Vessel, ft

f = refrigerant factor, see chart.

$$C = f * D * L$$

Refrigerant	f	Refrigerant	f
R-11	1.00	R-401A (MP-39)	1.60
R-12	1.60	R-402A (HP-80)	2.50
R-13, R-13B1	2.00	R-404A (HP-62)	2.50
R-14	2.50	R-406A	1.60
R-22	1.60	R-407C	1.60
R-113	1.00	R-408A	2.00
R-114	1.60	R-409A (FX-56)	1.60
R-115	2.50	R-410A (AZ-20)	2.50
R-123	1.00	R-500	1.60
R-134a	1.60	R-502	2.50
R-142b	1.00	R-600 (n-Butane)	1.00
R-152a	1.00	R-600a (Isobutane)	1.00
R-170 (Ethane)	1.00	R-717 (Ammonia)	0.50
R-290 (Propane)	1.00	R-744 (CO2)	1.00
R-1150 (Ethylene)	1.00	R764	1.00

Installation Notes

1. The installation location of the Pressure Relief Valve shall be above the liquid line, where the inlet to the relief valve should only be exposed to vapor or gas.
2. The Pressure Relief Valve should not be discharged prior to installation or when pressure testing the system.
3. Pressure Relief Valves should be mounted vertically.
4. Henry Technologies' Pressure Relief Valves are designed to be replaced after opening to full discharge. The set pressure after a discharge will most often be 5-15% lower than the original setting. This can be due to debris exiting the system through the valve which had deposited upon the seat disc, and altering the alignment of the internal parts.
5. Additional installation notes are shown on the instruction sheet accompanying the Pressure Relief Valve, instruction sheet drawing number 5-025-002.
6. Pressure Relief Valves should not be installed on discharge lines, as the continuous high temperatures may have adverse effects on the relief valve's performance.
7. Henry Technologies follows the recommendation provided by the International Institute of Ammonia Refrigeration (IIAR) in their Bulletin 109 "IIAR Minimum Safety Criteria For a Safe Ammonia Refrigeration System" recommends to replace Pressure Relief Valves on a five year interval. If a Pressure Relief Valve opens to full discharge it should be replaced immediately.

PRESSURE INDICATOR

The function of the Pressure Indicator is to provide visual indication in the event of a rupture disc burst. If the disc has ruptured, the Pressure Relief Valve will have discharged and must be replaced.

Applications

The G15 Pressure Indicator is intended to be used as part of the Henry Sentry Safety Device Assembly. The indicator is suitable for use with ammonia, HCFC and HFC refrigerants.

Main Features

- NPT connection
- Easy to read large indicator dial
- Stainless steel movement

Technical Specifications

Maximum working pressure = 800 PSI (55.2 Bar)

Allowable operating temperature = -40°F to +150°F (-40°C to +65°C)

Materials of Construction

The case and movement are made from stainless steel. The dial window is made from plexiglass.



Part No	Weight (oz)
G15	0.95

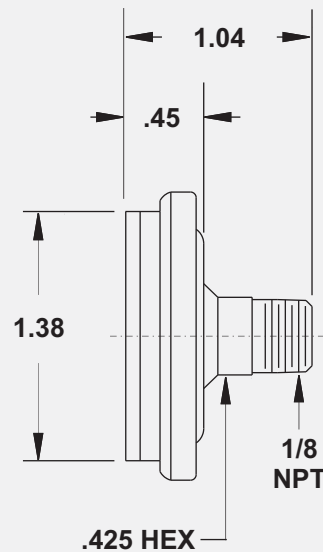
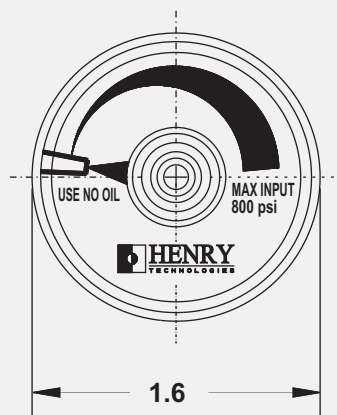

RUPTURE DISCS

The function of a Rupture Disc is to protect against accidental over-pressure of a pressure vessel due to system malfunction or fire. A Rupture Disc is generally used in combination with a Henry Technologies' Pressure Relief Valve.

Applications

A Rupture Disc protects against any leakage or weeping of refrigerant through a relief valve. A rupture disc can also be used in combination with a pressure gauge and/or pressure switch to detect if a relief valve has discharged.

Henry Technologies' Rupture Discs are designed to operate with gases and should not be used to prevent liquid over-pressure.

The 55 Series brass Rupture Discs are suitable for use with HCFC and HFC refrigerants and their associated oils, as well as other industrial fluids non-corrosive to brass, silver and nickel.

The 56 Series stainless steel Rupture Discs are suitable for use with Ammonia, HCFC and HFC refrigerants and their associated oils, as well as other industrial fluids non-corrosive to steel, silver and nickel.

It is recommended that all high side Rupture Discs should be replaced at least every 2 years. All low side discs should be replaced at least every 5 years. These intervals may have to be reduced if other regulations apply.

How it works

A foil disc is clamped in a holder. The disc is designed to burst at a pre-determined pressure - the set pressure. A reverse acting disc is used. This means that the disc is domed against the direction of the fluid pressure and designed to buckle due to compression forces, prior to bursting. Advantages of a reverse acting disc include being less sensitive to temperature, high operating pressures and improved fatigue life. Each disc is manufactured with a precision score mark. This score mark in combination with the buckling action causes the disc to burst. At burst, the disc is designed to hinge resulting in a large available flow area. The disc is designed to be non-fragmenting after rupturing.

Main Features

- Proven safe design
- High flow capacity
- Compact
- Reverse acting, non-fragmenting disc
- 2X 1/8 NPT gauge ports
- Helium leak tested
- Non-standard pressure settings available on request

Technical Specifications

Set pressure range (Brass) = 150 to 675 PSI (10.3 Bar to 46.5 Bar)

Set pressure range (Steel) = 150 to 450 PSI (10.3 Bar to 31.0 Bar)

Allowable operating temperature = -40°F to +225°F (-40°C to +107°C)

Henry Technologies' Rupture Discs are CE marked in accordance with PED. Additionally, all Rupture Discs are tested, certified and "UD" stamped to ASME Section VIII Div I.

Materials of Construction

For 55 and 56 series, the main bodies are made from brass and stainless steel respectively. For both series, the foil disc is made from either silver or nickel depending on pressure setting.

Installation - Notes

1. Connect the Rupture Disc either directly to the pressure vessel or to a three-way valve above the liquid refrigerant level in the vapor space.
2. The Rupture Disc is comprised of a two-piece body design. To avoid damage during assembly or removal, the product Installation Instructions must be followed.
3. The pipework must not impose loads on the rupture disc. Loads can occur due to misalignment, thermal expansion, discharge gas thrust, etc.



- ① Inlet
- ② Outlet
- ③ Gauge port, 1/8 NPT
- ④ Rupture disc

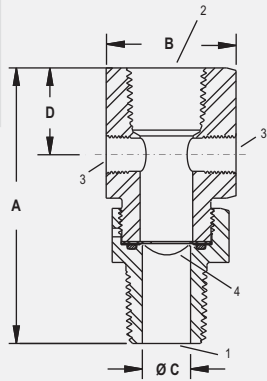

Part No	Type	NPT (inch)		Dimensions (inch)				STD Rupture Disc setting at 72°F (PSI)	Capacity lbs. Air/min	Weight (lbs)
		Inlet	Outlet	A	B	ØC	D			
5525-235-CE	Brass	3/8	3/8	2.94	1-1/4 Hex	0.375	0.79	235	25.5	0.69
5525-300-CE								300	32.2	
5525-350-CE								350	37.3	
5525-400-CE								400	42.5	
5525-450-CE								450	47.6	
5525-600-CE								600	63.0	
5525-650-CE								650	68.1	
5526-235-CE	Brass	1/2	1/2	2.62	1-1/4 Hex	0.500	0.79	235	45.3	0.68
5526-300-CE								300	57.2	
5526-350-CE								350	66.3	
5526-400-CE								400	75.5	
5526-450-CE								450	84.6	
5526-600-CE								600	110.8	
5526-650-CE								650	119.8	
5626-150-CE	Stainless Steel	1/2	1/2	2.96	Ø1.13	0.500	0.92	150	29.8	0.62
5626-250-CE								250	52.1	
5626-300-CE								300	57.2	
5627-150-CE	Stainless Steel	3/4	3/4	3.29	Ø1.50	0.750	0.92	150	35.8	1.44
5627-250-CE								250	57.7	
5627-300-CE								300	68.7	
5628-150-CE	Stainless Steel	1	1	3.73	Ø1.72	1.000	1.27	150	67.1	1.36
5628-250-CE								250	108.2	
5628-300-CE								300	128.7	
5629-150-CE	Stainless Steel	1-1/4	1-1/4	3.84	Ø1.98	1.312	1.27	150	91.4	1.56
5629-250-CE								250	147.2	
5629-300-CE								300	175.2	

Selection Guidelines

- The Rupture Disc pressure setting should be the same as the Henry Technologies' Pressure Relief Valve setting.
- The stamped capacity of a spring loaded Pressure Relief Valve when installed with a Rupture Disc between the inlet of the valve and the vessel shall be multiplied by a factor 0.90 of the rated relieving capacity of the Pressure Relief Valve alone.
- The stamped burst pressure is subject to a manufacturing tolerance of +/- 5%. This tolerance should be taken into account when specifying a Rupture Disc setting (refer to table).
- It is recommended that the maximum operating pressure of the system is no more than 70% of the stamped burst pressure, in order to minimize the risk of premature fatigue failure of the disc. If operating pressures exceed 90% of the stamped burst pressure, the Rupture Disc should be replaced immediately.
- The design fatigue strength of each Rupture Disc is 100,000 pressure cycles. Fatigue life will be reduced by excessive pressures or temperatures, corrosion, damage, etc.

Rupture Disc manufacturing tolerance

Pressure setting (PSI)	Pressure range (PSI)
150	143 - 158
200	190 - 210
235	223 - 247
250	238 - 263
300	285 - 315
350	333 - 368
360	342 - 378
400	380 - 420
450	428 - 473
600	570 - 630
650	618 - 683

THREE-WAY DUAL SHUT-OFF VALVES

The function of a Three-Way Valve is to permit replacement of one of the Pressure Relief Devices, while the other is protecting the pressure vessel. In this way, a vessel is protected from over-pressure during servicing and removal of the Pressure Relief Valve. The system refrigerant charge is not required to replace a Pressure Relief Device.

Applications

The 92 Series Three-Way Valves are suitable for use with HCFC and HFC refrigerants and their associated oils, as well as other industrial fluids non-corrosive to brass and steel.

The 802 Series Three-Way Valves are suitable for use with ammonia, HCFC and HFC refrigerants and their associated oils, as well as other industrial fluids non-corrosive to steel.

Main Features

- NPT Connections
- Proven robust design
- Compact

Technical Specifications

92 Series

Maximum working pressure = 675 PSI (46.6 Bar)

Allowable operating temperature = -20°F to +300°F (-29°C to +149°C)

802 Series

Maximum working pressure = 450 PSI (31.0 Bar)

Allowable operating temperature = -20°F to +300°F (-29°C to +149°C)

Materials of Construction

The 92 and 802 series valve bodies are made from forged brass and forged steel respectively. The stem is made from hardened steel. The stem seal packing is made from graphite based material. The seal cap is made from molded plastic.

Installation - Notes

1. Assemble the Three-Way Valve to a vessel using a high strength pipe nipple.
2. The pipework must not impose loads on the valve. Loads can occur due to misalignment, thermal expansion, discharge gas thrust, etc.

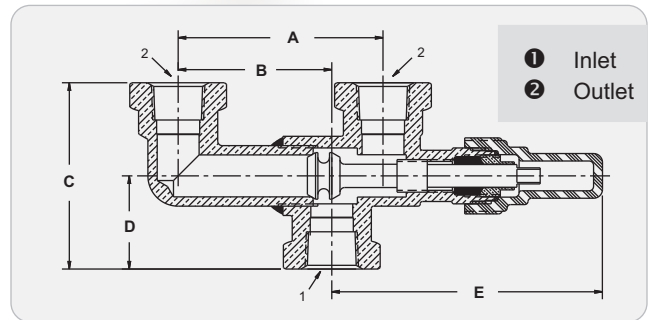

92 SERIES							
Part No	NPT (inch)	Dimensions (inch)					Weight (lbs)
		A	B	C	D	E	
923	3/8	2.75	2.06	2.50	1.25	3.60	1.15
925	1/2	2.75	2.06	2.50	1.25	3.60	1.05
927	3/4	2.75	2.06	2.75	1.38	3.92	1.67

802 SERIES*							
Part No	NPT (inch)	Dimensions (inch)					Weight (lbs)
		A	B	C	D	E	
8021A	1/2	3.63	2.32	3.38	1.75	5.75	3.21
8022A	3/4	3.63	2.32	3.38	1.75	5.75	3.00
8024	1	5.82	3.70	3.88	2.00	7.68	7.87
8025	1 1/4	5.82	3.70	3.88	2.00	7.68	6.92

*Suitable for ammonia

TRANSDUCER VALVE

The function of a Transducer Valve is to facilitate the mounting and isolation of a transducer.

Applications

Provides access to systems and mounting of a transducer to monitor systems performance. Henry Technologies' Transducer Valves are available in brass construction.

The 9290 valve is suitable for use with HCFC and HFC refrigerants and their associated oils, as well as other industrial fluids non-corrosive to brass and steel.

Main Features

- NPT and ODS connections
- 1/4" SAE Flare port with schrader fitting for checking transducer with gauge
- Provides isolation from system for replacing transducer
- Compact robust design

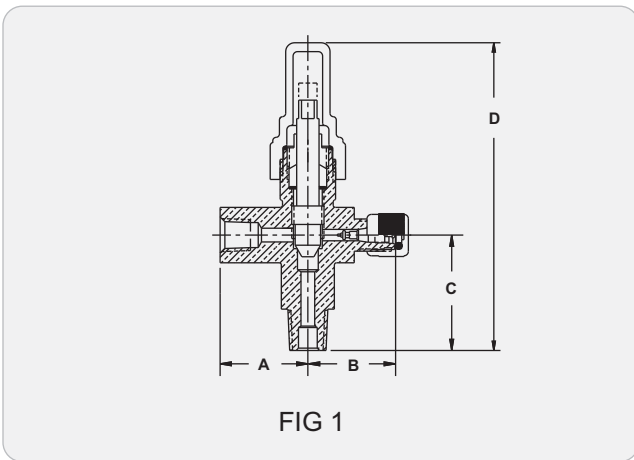

Technical Specifications

Maximum working pressure = 500 PSI (34.5 Bar)

Allowable operating temperature = -20°F to +300°F (-29°C to +149°C)

Materials of Construction

The valve bodies are made from forged brass. The stem is made from plated steel. The cap is made from molded plastic.

Part No	Fig No	Conn Size (inch)		Dimensions (inch)				Weight (lbs)
		Side	Bottom	A	B	C	D	
9290	1	1/8 FPT - 1/4 FL	1/4 MPT/1/4	1.19	1.19	1.56	4.16	0.52

NOTES

OIL MANAGEMENT SYSTEMS

This guide is intended for Oil Management Systems installed with scroll or reciprocating compressors using HCFC or HFC refrigerants. For other systems, please contact Henry Technologies Technical Support at 1-800-627-5148 for guidance.

A proper Oil Management System is essential to ensure compressor lubrication and energy efficient cooling.

An Oil Management System is a cost effective alternative to replacing expensive compressors due to incorrect lubrication. If selected and installed correctly, an Oil Management System will give years of trouble free operation, protecting the compressors from both low and excess oil levels, with little or no maintenance. Excessive oil within the system can lead to a slug of oil returning to the compressor. A slug of oil can be as damaging to a compressor as a slug of liquid refrigerant.

By removing oil from the discharge gas, the system efficiency is increased. Oil in a refrigeration or air conditioning system reduces the efficiency of the system by:

1. A reduction in heat transfer due to oil coating of the condenser and evaporator walls.
2. Displacing refrigerant volume resulting in a decrease in system mass flow.

Oil does not change phase from liquid to gas and is therefore a very poor refrigerant. A minimal amount of oil flowing through the system is necessary to provide lubrication to valves, but a very small amount is needed.

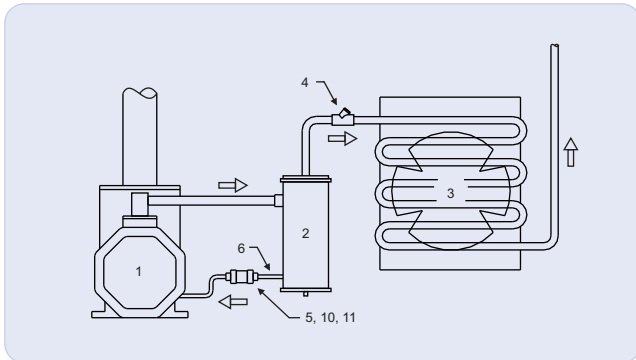

SINGLE COMPRESSOR SYSTEM

Single Compressor System

A single Compressor has the most basic oil system. The Compressor (1) discharge is piped to the inlet of an Oil Separator (2) and the outlet of the Oil Separator is piped to the Condenser (3). A Discharge Check Valve (4) should be fitted between the Separator and Condenser to ensure condensed liquid refrigerant is not returned to the separator during off cycles. An Oil Return Line (6) is connected from the Oil Separator through an Oil Strainer (5), Oil Filter (10) or Oil Filter-Drier (11), to the compressor crankcase.

As oil collects in the separator, the float valve will open to return oil, under discharge pressure, to the compressor crankcase. The float valve prevents hot gas from bypassing to the crankcase by closing when the oil level falls.

It is recognized best practice to fit a solenoid valve, sight glass, and shut-off valve in the oil return line. These components are not shown in the diagram.

Refer to equipment list for further details on each component in the oil system

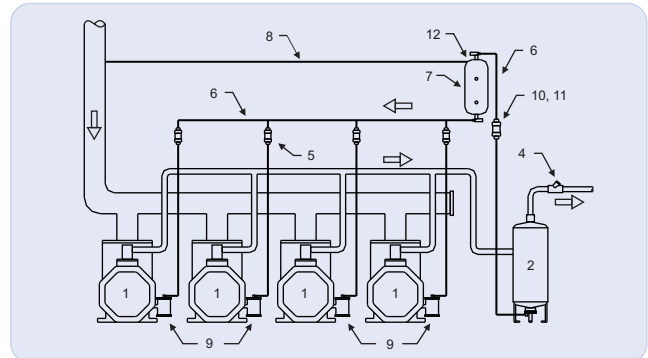

LOW PRESSURE OIL MANAGEMENT SYSTEM

Low Pressure Oil Management System

This system is normally used for parallel compressors and uses three main components; Oil Separator (2), Oil Reservoir (7) and Mechanical Oil Level Regulators (9). The common discharge is piped to the inlet of the Oil Separator and the outlet of the Oil Separator is piped to the Condenser. A Discharge Check Valve (4) should be fitted between the Separator and Condenser to ensure condensed liquid refrigerant is not returned to the separator. An Oil Return Line is (6) connected from the Oil Separator to the top valve of the Oil Reservoir (7). A Vent Line (8) is installed to the suction line, using a Reservoir Pressure Valve (12), to reduce the pressure in the Reservoir. This makes a low pressure system. The Reservoir Pressure Valve will maintain the Reservoir at a set pressure above suction. Although Mechanical Oil Level Regulators (9) are shown in the diagram, Electro-mechanical and Optronic Oil Level Regulators can also be used.

The bottom valve of the Oil Reservoir is piped to the Oil Level Regulators mounted on the compressor crankcases. These regulators open to feed oil as the oil level drops and close as the oil level rises to the set level. In this way, the oil level in each compressor is controlled. An Oil Strainer (5) should be used on each Regulator to remove debris from the oil. Alternatively, the Oil Strainers may be replaced by one Oil Filter (10) or Oil Filter-Drier (11) installed between the Separator and Oil Reservoir. Due to the scavenging nature of POE oil, it is recommended to install either an Oil Filter or Oil Filter-Drier on a HFC/POE system instead of individual Oil Strainers.

On dual temperature and satellite systems, ensure that all regulators see positive oil differential pressures within their allowable operating range.

It is recognized best practice to fit a solenoid valve, sight glass, and shut-off valve in the oil return line. These components are not shown in the diagram.

Refer to equipment list for further details on each component in the oil system

High Pressure Oil Management System

High Pressure Oil Management Systems remove the need for a separate Oil Reservoir. This type of system also reduces the amount of pipework and fittings.

A High Pressure Oil Management System relies on the Oil Level Regulators being able to operate with a high pressure differential. Mechanical Oil Level Regulators cannot be used on this type of system. The Electronic Oil Level Regulator (14) is recommended for this application. Electro-Mechanical Regulators can also be used. A High Pressure Oil Management System is not recommended for HCFC/mineral oil systems due to potential foaming problems.

The common discharge is piped to the inlet of the Oil Separator-Reservoir (13) and the outlet of the Separator-Reservoir is piped to the condenser. A Discharge Check Valve (4) should be fitted between the Separator and Condenser to ensure condensed liquid refrigerant is not returned to the Separator. The oil return connection, positioned at the bottom of the vessel, is piped to the Oil Level Regulators. An Oil Filter (10) or Oil Filter-Drier (11) should be installed between the Oil Separator-Reservoir and the Electronic Oil Level Regulators (14).

It is recognized best practice to fit a solenoid valve, sight glass, and shut-off valve in the oil return line. These components are not shown in the diagram.

Refer to equipment list for further details on each component in the oil system

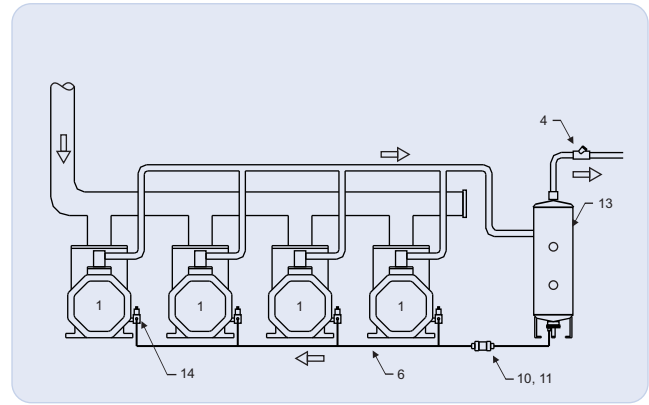

HIGH PRESSURE OIL MANAGEMENT SYSTEM

EQUIPMENT LIST FOR OIL LEVEL CONTROL

- 1. Compressor.**
- 2. Oil Separator** – The function of an Oil Separator is to remove oil from the discharge gas and return it to the compressor, either directly or indirectly. This helps maintain the compressor crankcase oil level and raises the efficiency of the system by preventing excessive oil circulation. Oil Separators are not 100% efficient, so installing an Oil Separator should not be viewed as a replacement for oil traps, accumulators, or good oil return piping practices. Henry Technologies' manufactures two different types of Oil Separators, Helical and Conventional.
- 3. Condenser.**
- 4. Discharge Check Valve** – The function of a Check Valve is to allow fluid flow in one direction only. This prevents condensed liquid refrigerant returning down the discharge line into the Separator. If this Check Valve is not installed the Separator can feed excessive liquid refrigerant to the Compressor on start up. This can cause oil dilution, excessive foaming, erratic oil pressures and possible compressor damage. The Check Valve must be installed after the Oil Separator, before the Condenser.
- 5. Oil Strainer** – The function of an Oil Strainer is to remove system debris from the refrigerant oil. Their purpose is to protect compressors and Oil Level Regulators from damage. For recommendations on HFC/POE systems, refer to section on oil filters and oil filter-driers.
- 6. Oil Return Line.**
- 7. Oil Reservoir** – The function of an Oil Reservoir is to provide a holding charge of oil, as part of a Low Pressure Oil Management System. The amount of oil circulating in a system varies depending on the operating conditions. The Oil Reservoir caters to these fluctuations by providing additional storage capacity.
- 8. Vent Line.**
- 9. Mechanical Oil Level Regulators** – The function of a Mechanical Oil Level Regulator is to control the oil level in the compressor crankcase. This protects the compressors from damage. There are two main types of Oil Level Regulators, fixed level and adjustable level. The fixed level regulators have an allowable oil pressure differential range of 5 to 30 PSI (0.35 to 2.1 Bar). The adjustable level regulators have an allowable oil pressure differential range of 5 to 90 PSI (0.35 to 6.2 Bar). Oil pressure differential is the difference between the crankcase pressure and the pressure in the Oil Reservoir. Gravity pressure head should be included also, if applicable. Some regulator models are fitted with an equalization connection that enables the oil levels between several compressors to be balanced.
- 10. Oil Filter** – The function of an Oil Filter is to remove system debris from the refrigerant oil. An Oil Filter is recommended for HFC/POE systems instead of individual Oil Strainers, where filtration only is required.
- 11. Oil Filter-Drier** – The function of an Oil Filter-Drier is to remove both system debris and moisture from the refrigerant oil. An Oil Filter-Drier is recommended for HFC/POE systems instead of individual Oil Strainers, where both filtration and moisture removal is required.
- 12. Reservoir Pressure Valve** – The function of a Reservoir Pressure Valve is to maintain a positive pressure in the Oil Reservoir above the compressor crankcase pressure. Two different pressure settings are available; 5 psi (0.34 Bar) and 20 psi (1.38 Bar). A higher pressure differential will increase the oil flow rate from the oil reservoir back to the compressors. The pressure setting should be selected taking into account the allowable oil pressure differential of the Oil Level Regulator type.
- 13. Oil Separator-Reservoir** – The function of an Oil Separator-Reservoir is to provide a Oil Separator and Oil Reservoir in one unit. It is designed for High Pressure Oil Management Systems and used with Electro-Mechanical or Electronic Regulators.
- 14. Electronic Oil Level Regulator** – The function of the Electronic Oil Level Regulator is to control the oil level in the Compressor crankcase. This protects the Compressors from damage. This regulator can be used on Low or High Pressure Oil Management Systems.

OIL SEPARATOR SIZING GUIDELINES

Determining Oil Separator Gas DCFM

Correct Oil Separator sizing is essential for proper oil separation and minimal pressure drop across the separator. The following example will demonstrate how to select an Oil Separator based on a discharge cubic feet per minute (DCFM) value that has been calculated using four primary system parameters.

It is important to determine the DCFM value of the hot gas flow approaching the Oil Separator. The DCFM values entering the Oil Separator are shown as a minimum and maximum allowed. The minimum DCFM rating is based on the minimum allowed gas velocity for oil separation to occur, while the maximum DCFM rating is when a 0.75-1.0 psi pressure drop will develop across the Oil Separator.

Selection Method

To determine DCFM for Oil Separator sizing the following parameters are needed:

- Evaporating Temperature
- Condensing Temperature
- Cooling Capacity (in Tons)
- Refrigerant Type

Use the following method to determine the DCFM needed for Oil Separator Selection

1. Find the corresponding DCFM/Ton factor by locating the appropriate evaporating and condensing temperatures and refrigerant type on the DCFM/Ton Factor table.
2. Multiply the DCFM/Ton factor by the Cooling Capacity to determine the resulting DCFM for Separator sizing.
3. Use the associated Oil Separator DCFM Capacity table in each Oil Separator section to determine Oil Separator models where the calculated system DCFM falls between the minimum and maximum DCFM rating.
4. From the selected models, choose appropriate Oil Separator by taking into account connection size and serviceable/non-serviceable choices.

If the refrigerant type required is not listed or if there are any questions about proper separator sizing please contact Technical Support at 1-800-627-5148.

Selection Example

The following system parameters will be used for the sizing example:

- Evaporating Temperature = -40°F
- Condensing Temperature = 105°F
- Cooling Capacity (in Tons) = 20 Tons
- Refrigerant Type = R-404A
- Line Size = 1-5/8"
- Oil Separator type desired = Serviceable Helical Oil Separator

1. The DCFM/Ton table shows a DCFM/Ton factor of 0.790 for the chosen system parameters
2. System DCFM = DCFM/Ton factor x Cooling capacity

$$0.790 \times 20 = 15.8 \text{ DCFM}$$

3. The Helical Oil Separator DCFM Capacity table lists the following separators that meet the DCFM requirements:

S-5190, S-5192, S-5194, S-5290, S-5292, and S-5294

4. Based on the line size and desired type, the S-5292 would be the best choice*.

*Selecting a Helical Oil Separator with a connection size smaller than the line size will help keep the velocity high needed for separation, if the system experiences frequent unloading, but may lead to a slightly higher pressure drop across the Oil Separator at full capacity. Selecting a Helical Oil Separator with a connection size larger than the line size is not recommended due to the loss of velocity as the discharge gas enters the Oil Separator. Please contact Technical Support at 1-800-627-5148 for assistance or recommendations when selecting Oil Separators.

OIL SEPARATOR DCFM / TON FACTOR

Evaporating Temperature (°F)	Condensing Temperature (°F)	Refrigerant Type					
		R134a	R22	R404A	R507	R407A	R407C
-40	80	1.547	1.012	0.977	0.956	0.953	1.050
	85	1.443	0.947	0.923	0.899	0.867	0.981
	90	1.363	0.894	0.902	0.859	0.839	0.946
	95	1.291	0.845	0.865	0.822	0.792	0.893
	100	1.261	0.822	0.821	0.812	0.771	0.838
	105	1.198	0.779	0.790	0.781	0.735	0.795
	110	1.128	0.733	0.781	0.740	0.688	0.772
	115	1.078	0.696	0.757	0.715	0.662	0.734
-20	80	1.476	0.981	0.922	0.905	0.910	1.007
	85	1.377	0.917	0.870	0.849	0.827	0.940
	90	1.298	0.865	0.848	0.809	0.800	0.905
	95	1.228	0.817	0.811	0.772	0.753	0.854
	100	1.197	0.794	0.768	0.761	0.732	0.801
	105	1.135	0.752	0.737	0.730	0.696	0.758
	110	1.068	0.707	0.726	0.689	0.651	0.734
	115	1.018	0.671	0.700	0.663	0.625	0.698
0	80	1.413	0.953	0.875	0.860	0.878	0.969
	85	1.317	0.891	0.824	0.806	0.797	0.904
	90	1.240	0.840	0.801	0.766	0.770	0.869
	95	1.171	0.793	0.765	0.730	0.724	0.819
	100	1.140	0.770	0.722	0.717	0.704	0.767
	105	1.080	0.729	0.691	0.686	0.668	0.725
	110	1.014	0.685	0.679	0.647	0.624	0.702
	115	0.965	0.650	0.652	0.620	0.598	0.666
20	80	1.357	0.929	0.834	0.821	0.845	0.936
	85	1.263	0.868	0.785	0.769	0.767	0.872
	90	1.189	0.818	0.762	0.730	0.741	0.838
	95	1.121	0.772	0.725	0.693	0.695	0.789
	100	1.089	0.749	0.684	0.680	0.675	0.738
	105	1.031	0.708	0.653	0.649	0.639	0.697
	110	0.967	0.666	0.640	0.611	0.597	0.674
	115	0.919	0.631	0.613	0.584	0.571	0.638
40	80	1.306	0.909	0.802	0.787	0.814	0.909
	85	1.215	0.849	0.754	0.737	0.738	0.847
	90	1.142	0.800	0.730	0.698	0.713	0.813
	95	1.076	0.754	0.695	0.663	0.668	0.765
	100	1.045	0.731	0.654	0.649	0.648	0.715
	105	0.987	0.691	0.624	0.618	0.613	0.675
	110	0.925	0.649	0.609	0.580	0.572	0.652
	115	0.878	0.615	0.582	0.554	0.546	0.616

OIL SEPARATOR-RESERVOIRS

The function of a Helical Oil Separator-Reservoir is to remove and store oil from the discharge gas so that it can be returned to the Compressor.

Applications

Helical Oil Separator-Reservoirs can be used in a variety of applications. Common applications include multi-compressor racks. Helical Oil Separator-Reservoirs are intended for High Pressure Oil Management Systems.

These products are designed for use with scroll and reciprocating type compressors. They are not recommended for screw or rotary vane compressors. Henry Technologies' Oil Separators are suitable for use with HCFC and HFC refrigerants, and their associated oils, as well as other industrial fluids non-corrosive to steel, copper and Teflon.

How it works

The Helical Separator does not rely on any moving parts for oil separation. As the oil laden hot gas enters the separator it is directed in a spiral motion around a helical flighting. The centrifugal forces act on the gas/oil mixture causing heavier oil particles to spin to the perimeter where they impact an internal screen. The screen layer functions as both an oil stripping and draining medium. Separated oil flows downward along the boundary of the shell through a baffle and into an oil collection chamber. The specially engineered baffle isolates the oil collection chamber and eliminates oil re-entrainment by preventing turbulence. The virtually oil free refrigerant gas then exits through a screen fitting just below the lower edge of the helical flighting. Oil Separator-Reservoirs do not have an oil float assembly. Instead, a dip tube is located in the oil chamber that feeds oil to the compressor through a High Pressure Oil Management System.

Main Features

- *Patented Henry Technologies Design
- ODS refrigerant connections
- SAE flare Rotalock valve oil connection
- High oil separation efficiency - up to 99%
- Low pressure drop
- Integrated oil reservoir

Technical Specifications

Maximum working pressure = 450 PSI (31 Bar)

Allowable operating temperature = +15°F to +300°F (-10°C to +149°C)

Oil Separators are UL and C-UL Listed by Underwriters Laboratories, Inc. Henry Technologies' Oil Separators are designed and registered for use in Canada. Please contact Technical Support at 1-800-627-5148 for CRN details and list of approved provinces and territories.

Materials of Construction

The main components; shell, end caps and connections are made from carbon steel.

Installation - Notes

Full instructions are given in the Product Instruction Sheet, included with each Oil Separator-Reservoir.

Selection Guidelines

Henry Technologies' Oil Separator-Reservoirs rely on adequate gas velocities to allow for oil extraction from the hot gas so sizing according to the DCFM rating is important. The Oil Separator-Reservoir DCFM Rating table shows the min/max ratings allowed for sufficient separation and low pressure drop. When sized correctly the Oil Separator-Reservoir models will separate up to 99% of the oil from the hot gas. Please contact Technical Support at 1-800-627-5148 for assistance or recommendations when selecting Oil Separators.



- ❶ Inlet ODS
- ❷ Outlet ODS
- ❸ Oil Return
- ❹ Sight Glass
- ❺ 1/2" NPT Fitting

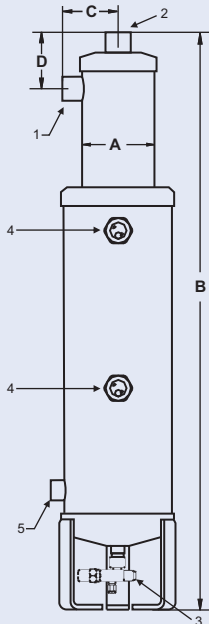

FIG 1

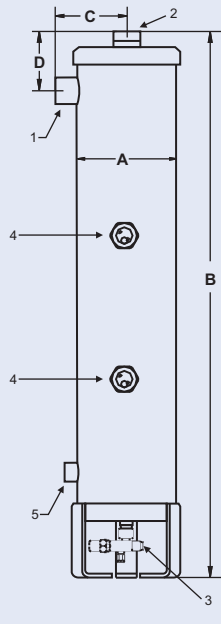

FIG 2

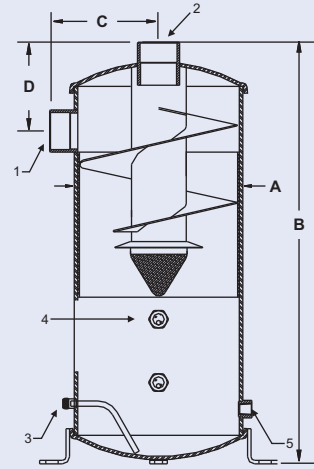

FIG 3

Part No	Fig No	ODS (inch)	Dimensions (inch)				Pre-charge Amount (gal*)	Weight (lbs)
			A	B	C	D		
S-5388	1	1 1/8	4.0	32.0	3.00	2.97	2	35.0
S-5390	2	1 3/8	6.0	33.5	4.25	3.69	2	36.0
S-5392	2	1 5/8	6.0	35.5	4.25	3.95	2	37.0
S-5394	2	2 1/8	6.0	35.5	4.38	4.19	2	37.0
S-5302	3	2 1/8	8.0	25.5	5.38	5.07	2	43.0
S-5303	3	2 5/8	10.0	30.0	6.50	5.63	2	64.0
S-5304	3	3 1/8	12.0	30.0	7.75	6.32	2	106.0

*on existing installation pre-charge with 1 Gallon

Part No	Oil Separator-Reservoir DCFM Capacity											
	R-507		R-404A		R22		R134a		R407A		R407C	
	Min DCFM	Max DCFM	Min DCFM	Max DCFM	Min DCFM	Max DCFM	Min DCFM	Max DCFM	Min DCFM	Max DCFM	Min DCFM	Max DCFM
S-5388	6.8	14.9	6.8	14.9	6.8	18.3	6.9	21.2	6.8	16.3	6.8	17.0
S-5390	12.6	26.4	12.6	26.4	12.7	32.0	12.6	37.2	12.6	28.9	12.7	30.1
S-5392	13.6	34.7	13.6	34.8	13.6	41.9	13.8	48.6	13.5	37.9	13.6	39.3
S-5394	14.6	44.3	14.8	44.4	14.7	53.4	14.9	62.3	14.7	48.4	14.6	50.2
S-5302	26.9	60.3	26.5	60.5	26.7	72.9	26.6	84.8	26.8	66.1	26.8	68.7
S-5303	51.9	88.8	52.0	88.8	52.0	107.0	52.0	124.8	51.8	96.7	52.0	100.7
S-5304	74.7	130.1	74.6	130.3	74.7	157.1	74.7	182.7	74.5	141.8	74.7	147.9

OIL SEPARATORS

Helical

The function of a Helical Oil Separator is to remove oil from the discharge gas and return it to the Compressor either directly or through an Oil Management System.

Applications

Helical Oil Separators are typically used on multi-compressor refrigeration racks or air conditioning units. They are primarily intended for use with scroll and reciprocating type compressors, and not intended to be used with screw or rotary vane compressors. Helical Oil Separators are intended for Low Pressure Oil Management Systems. Helical Oil Separators are suitable for use with HCFC and HFC refrigerants, and their associated oils, as well as other industrial fluids non-corrosive to steel, copper and brass.

Main Features

- *Patented Henry Technologies' Design
- ODS refrigerant connections
- SAE flare or ODS oil connection
- High oil removal efficiency - up to 99%
- Low pressure drop
- No moving parts within oil separation zone
- Serviceable models available, S-52** series
- 1/8 NPT oil drain
- Magnet on oil float to collect debris
- Replacement parts available

Standard 3/8" flare oil return connection; 3/8" ODS oil return connection available by ordering an "X" suffix (i.e. S-5292X).

How it Works

The Helical Separator does not rely on any moving parts for oil separation. As the oil laden hot gas enters the separator it is directed in a spiral motion around a helical fighting. The centrifugal forces act on the gas/oil mixture causing heavier oil particles to spin to the perimeter where they impact an internal screen. The screen layer functions as both an oil stripping and draining medium. Separated oil flows downward along the boundary of the shell through a baffle and into an oil collection chamber. The specially engineered baffle isolates the oil collection chamber and eliminates oil re-entrainment by preventing turbulence. The virtually oil free refrigerant gas then exits through a screen fitting just below the lower edge of the helical fighting. Oil flow out of the separator is controlled by an oil float assembly in the bottom of the collection chamber. The oil may be returned directly to the compressor or to an Oil Management System.

Technical Specifications

Maximum working pressure = 450 PSI (31 Bar)

Allowable operating temperature = +15°F to +300°F (-10°C to +149°C)

Henry Technologies' Helical Oil Separators are UL and C-UL Listed by Underwriters Laboratories, Inc. Additionally, Helical Oil Separators are designed and registered for use in Canada. Please contact Technical Support at 1-800-627-5148 for CRN details and list of approved provinces and territories.

Materials of Construction

The main components; shell, end caps and connections are made from carbon steel. The float assemblies are made from stainless steel, brass and copper.

Installation - Notes

Full instructions are given in the Oil Level Control Manual, included with each separator.

Selection Guidelines

Henry Technologies' Helical Oil Separators rely on adequate gas velocities to allow for oil extraction from the hot gas so sizing according to the DCFM rating is important. The Helical Oil Separator DCFM Rating table shows the min/max ratings allowed for sufficient separation and low pressure drop. When sized correctly the helical models will separate up to 99% of the oil from the hot gas. Please contact Technical Support at 1-800-627-5148 for assistance or recommendations when selecting Oil Separators.



- ❶ Inlet ODS
- ❷ Outlet ODS
- ❸ 3/8" SAE Flare Oil Return
- ❹ 3/8"-16 Stud

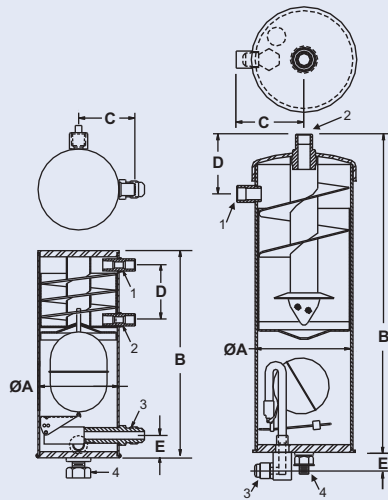

FIG 1

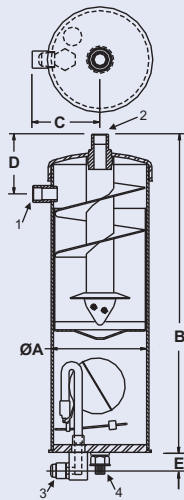

FIG 2

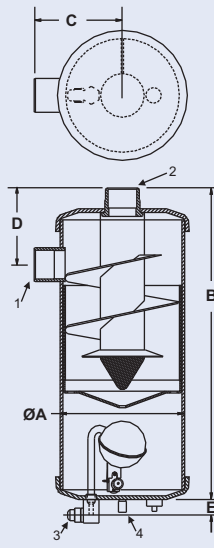

FIG 3

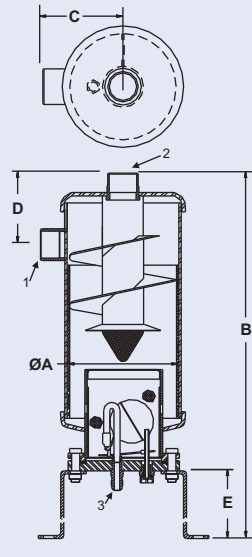

FIG 4

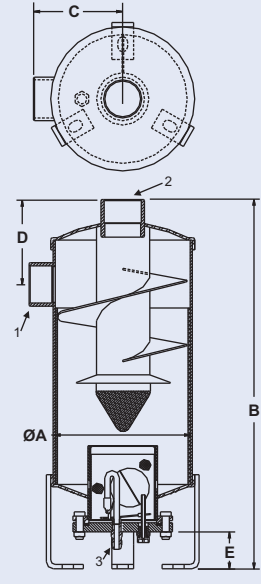

FIG 5

NON-SERVICEABLE OIL SEPARATORS

Part No	ODS (inch)	Fig No	Dimensions (inch)					Pre-charge Oil (oz)	Weight (lbs)
			ØA	B	C	D	E		
S-5180	1/4	1	2.5	6.38	1.75	1.69	0.69	14	2.65
S-5181	3/8	1	2.5	7.50	1.75	3.71	0.65	14	3.09
S-5182	1/2	2	4.0	13.00	2.75	2.44	0.75	14	7.50
S-5185	5/8	2	4.0	15.00	2.75	2.50	0.75	14	8.60
S-5187	7/8	2	4.0	17.00	3.00	2.94	0.75	14	10.14
S-5188	1 1/8	2	4.0	19.00	3.00	3.06	0.75	14	10.14
S-5190	1 3/8	3	6.0	15.00	4.25	3.69	0.75	40	19.62
S-5192	1 5/8	3	6.0	17.00	4.25	3.95	0.75	40	20.94
S-5194	2 1/8	3	6.0	17.00	4.38	4.19	0.75	40	21.38

Notes: Standard 3/8" flare oil return connection. 3/8" O.D.S. oil return connection available by ordering an "X" suffix (i.e. S-5292X). See Selection Guidelines for sizing instructions.

SERVICEABLE OIL SEPARATORS

Part No	ODS (inch)	Fig No	Dimensions (inch)					Pre-charge Oil (oz)	Weight (lbs)
			ØA	B	C	D	E		
S-5290	1 3/8	4	6.0	20.19	4.25	3.69	4.94	25	25.0
S-5292	1 5/8	4	6.0	22.00	4.25	3.95	4.94	25	25.0
S-5294	2 1/8	4	6.0	22.25	4.38	4.19	4.94	25	25.0
S-5202	2 1/8	5	8.0	24.00	5.38	4.88	4.94	25	39.0
S-5203	2 5/8	5	10.0	27.29	6.50	5.63	4.94	25	58.0
S-5204	3 1/8	5	12.0	29.31	7.75	6.45	4.94	25	94.0

Notes: Standard 3/8" flare oil return connection. 3/8" O.D.S. oil return connection available by ordering an "X" suffix (i.e. S-5292X). See Selection Guidelines for sizing instructions.

Part No	Helical Oil Separator DCFM Capacity											
	R-507		R-404A		R22		R134a		R407A		R407C	
	Min DCFM	Max DCFM	Min DCFM	Max DCFM	Min DCFM	Max DCFM	Min DCFM	Max DCFM	Min DCFM	Max DCFM	Min DCFM	Max DCFM
S-5180	0.29	0.45	0.29	0.45	0.29	0.54	0.29	0.63	0.29	0.49	0.29	0.51
S-5181	0.43	1.42	0.44	1.42	0.44	1.71	0.44	2.00	0.42	1.54	0.42	1.61
S-5182	1.6	3.1	1.6	3.1	1.6	3.7	1.6	4.3	1.6	3.3	1.6	3.5
S-5185	1.9	4.1	1.9	4.1	1.9	5.0	1.9	5.8	1.9	4.5	1.9	4.7
S-5187	4.8	11.2	4.8	11.2	4.8	13.5	4.9	15.7	4.8	12.2	4.8	12.7
S-5188	6.8	14.9	6.8	14.9	6.8	18.3	6.9	21.2	6.8	16.3	6.8	17.0
S-5190	12.5	26.4	12.5	26.4	12.5	31.8	12.6	37.1	12.5	28.8	12.5	30.0
S-5192	13.5	34.6	13.5	34.6	13.6	41.8	13.6	48.6	13.5	37.8	13.5	39.3
S-5194	14.7	44.2	14.7	44.2	14.7	53.3	14.7	62.1	14.7	48.2	14.7	50.1
S-5290	12.6	26.4	12.6	26.4	12.7	32.0	12.6	37.2	12.6	28.9	12.7	30.1
S-5292	13.6	34.7	13.6	34.8	13.6	41.9	13.8	48.6	13.5	37.9	13.6	39.3
S-5294	14.6	44.3	14.8	44.4	14.7	53.4	14.9	62.3	14.7	48.4	14.6	50.2
S-5202	26.9	60.3	26.5	60.5	26.7	72.9	26.6	84.8	26.8	66.1	26.8	68.7
S-5203	51.9	88.8	52.0	88.8	52.0	107.0	52.0	124.8	51.8	96.7	52.0	100.7
S-5204	74.7	130.1	74.6	130.3	74.7	157.1	74.7	182.7	74.5	141.8	74.7	147.9

OIL SEPARATORS

Conventional

The function of an Oil Separator is to remove oil from the discharge gas and return it to the Compressor either directly or through an Oil Management System.

Applications

Conventional Oil Separators can be used in a wide variety of applications. Common applications include multi-compressor racks and remote condensing units. These separators are designed for use with scroll and reciprocating type compressors. They are not recommended for screw or rotary vane compressors. Conventional oil separators are intended for Low Pressure Oil Management Systems.

Conventional Oil Separators are suitable for use with HCFC and HFC refrigerants, and their associated oils, as well as other industrial fluids non-corrosive to steel, copper and brass.

Main Features

- ODS refrigerant connection
- SAE flare oil connections
- Low pressure drop
- No moving parts within oil separation zone
- Serviceable models available, S-19** series
- 1/8" NPT oil drain
- Magnet on oil float to collect debris
- Replacement parts available

Technical Specifications

Maximum working pressure = 450 PSI (31 Bar)

Allowable operating temperature = +15°F to +300°F (-10°C to +149°C)

Henry Technologies' Conventional Oil Separators are UL and C-UL Listed by Underwriters Laboratories, Inc. Additionally, Conventional Oil Separators are designed and registered for use in Canada. Please contact Technical Support at 1-800-627-5148 for CRN details and list of approved provinces and territories.

Materials of Construction

The main components; shell, end caps and connections are made from carbon steel. The separation screens are made from brass. The float assemblies are made from stainless steel, brass and copper.

Installation - Notes

Full instructions are given in the Oil Level Control Manual, included with each separator.

Selection Guidelines

Henry Technologies' Conventional Oil Separators should not be undersized (calculated DCFM greater than 125% of nominal), which would cause higher gas velocities to pass through the inlet/outlet screens. Higher flow velocities may cause pre-mature failure of the screens. Please contact Technical Support at 1-800-627-5148 for assistance or recommendations when selecting Oil Separators.



- ❶ Inlet ODS
- ❷ Outlet ODS
- ❸ 3/8" SAE Flare Oil Return
- ❹ 3/8" X 16 Stud

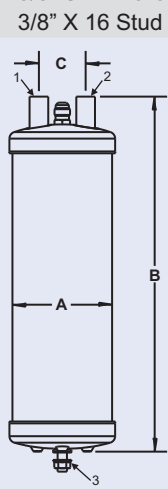

FIG 1

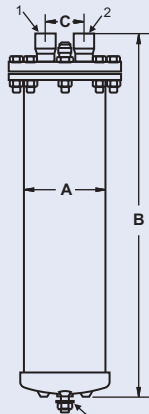

FIG 2

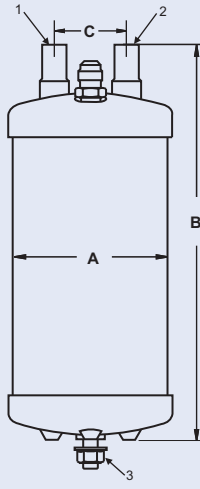

FIG 3

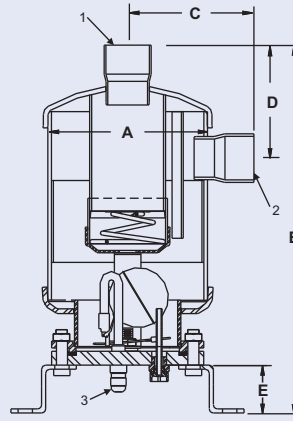

FIG 4

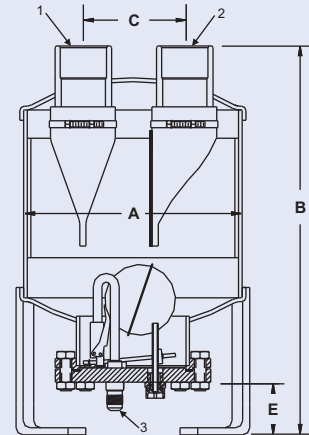

FIG 5

NON-SERVICABLE OIL SEPARATORS

Part No	ODS (inch)	Fig No	Dimensions (inch)			Min Discharge CFM	Max Discharge CFM	Pre-charge Amount	Weight (lbs)
			ØA	B	C				
S-5580	1/4	1	4.0	8.25	1.88	0.25	0.75	12	4.2
S-5581	3/8	1	4.0	8.25	1.88	0.33	1.0	12	4.2
S-5582	1/2	1	4.0	10.25	1.88	0.50	1.5	12	5.1
S-5585	5/8	1	4.0	14.25	1.88	1.32	4.0	12	7.1
S-5587	7/8	1	4.0	17.75	1.88	2.15	6.5	12	7.9
S-5588	1 1/8	1	4.0	21.00	1.88	2.64	8.0	12	9.0
S-5590	1 3/8	1	4.0	21.25	1.88	3.30	10.0	12	9.9
S-5687	7/8	3	6.0	11.13	3.00	2.48	7.5	30	12.1
S-5688	1 1/8	3	6.0	15.38	3.00	2.97	9.0	30	15.0
S-5690	1 3/8	3	6.0	15.63	3.00	3.63	11.0	30	15.0
S-5692	1 5/8	3	6.0	18.63	3.00	4.62	14.0	30	18.1
S-5694	2 1/8	3	6.0	19.13	3.00	7.43	22.5	30	19.0

SERVICABLE OIL SEPARATORS

Part No	ODS (inch)	Fig No	Dimensions (inch)				Min Discharge CFM	Max Discharge CFM	Pre-charge Amount	Weight (lbs)
			ØA	B	C	D				
S-5882	1/2	2	4.0	10.25	1.88	N/A	.50	1.5	12	9.0
S-5885	5/8	2	4.0	14.25	1.88	N/A	1.32	4.0	12	11.0
S-5887	7/8	2	4.0	17.75	1.88	N/A	1.98	6.0	12	12.1
S-5888	1 1/8	2	4.0	12.00	1.88	N/A	2.64	8.0	12	13.0
S-5890	1 3/8	2	4.0	21.25	1.88	N/A	3.30	10.0	12	13.0
S-5792	1 5/8	4	6.0	29.25	4.75	5.00	4.62	14.0	20	27.1
S-5794	2 1/8	4	6.0	29.56	4.60	5.25	7.43	22.5	20	27.1
S-1901	1 5/8	5	8.0	21.00	3.50	N/A	5.94	18.0	20	31.1
S-1902	2 1/8	5	8.0	21.00	3.50	N/A	8.91	27.0	20	32.0
S-1903	2 5/8	5	10.0	21.50	4.63	N/A	16.17	49.0	20	44.1
S-1904	3 1/8	5	12.0	25.75	5.56	N/A	22.44	68.0	20	75.0

OIL SEPARATORS

Coalescing - All-Welded

The function of a Coalescing Oil Separator is to remove oil from the discharge gas and return it to the Compressor either directly or through an Oil Management System.

Applications

The Coalescing Oil Separators are typically used on larger industrial refrigeration systems and rely on a coalescing element to remove oil from the hot gas. Once the filtering element becomes saturated with oil it will begin accumulating within the vessel. An optional float valve can be attached to control oil flow to an Oil Management System or straight to a compressor crankcase.

Henry Technologies' Coalescing Oil Separators are suitable for use with Ammonia, HCFC and HFC refrigerants, and their associated oils, as well as other industrial fluids non-corrosive to steel.

Main Features

- ODS and Butt Weld refrigerant connections
- NPT oil connections
- All welded steel design
- Designed specifically for reciprocating refrigeration compressors
- Five models available covering entire range of single stage and booster compressors
- Oil float valve assembly and shut off valves available as optional accessories.
- Can be mounted horizontal or vertical



CRN

Technical Specifications

Maximum working pressure = 400 PSI (27.5 Bar)

Allowable operating temperature = -20°F to +230°F (-29°C to +110°C)

Henry Technologies' Coalescing Oil Separators are constructed in accordance with ASME Section VIII. Additionally, Coalescing Oil Separators are designed and registered for use in Canada. Please contact Technical Support at 1-800-627-5148 for CRN details and list of approved provinces and territories.

Materials of Construction

All pressure bearing components and connections are made of steel.

- 1 Inlet 2 Outlet 3 3/4" NPT Drain 4 1/2" NPT Relief Port 5 Horizontal Mount 6 Vertical Mount

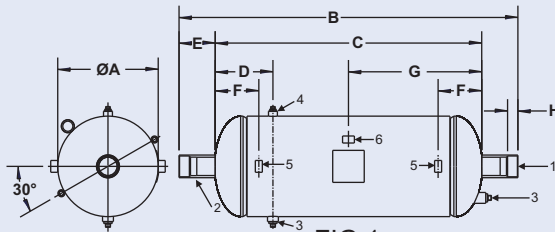

FIG 1

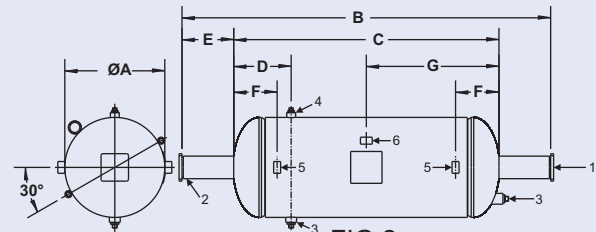

FIG 2

ODS CONNECTIONS*

Part No	ODS (inch)	Fig No	Dimensions (inch)								Weight (lbs)
			ØA	B	C	D	E	F	G	H	
COS-030F	2 1/8	1	8.63	33.13	23.31	4.93	4.91	4.93	11.74	1.37	78.0
COS-070F	2 5/8	1	12.75	43.00	33.82	7.33	4.59	5.54	16.91	1.31	238.0
COS-140F	3 1/8	1	16.00	51.00	41.80	7.53	4.60	6.66	20.93	1.69	333.0

*All ODS connection separators can be cut back to BW connections

BUTT WELD CONNECTIONS

Part No	BW (inch)	Fig No	Dimensions (inch)								Weight (lbs)
			ØA	B	C	D	E	F	G		
COS-030	2	2	8.63	37.03	23.31	4.93	6.86	4.93	11.73	78.0	
COS-070	2 1/2	2	12.75	47.00	33.82	7.33	6.59	5.54	16.91	238.0	
COS-140	3	2	16.00	55.06	41.86	7.53	6.60	6.66	20.93	333.0	
COS-205	4	2	18.00	65.00	51.70	9.04	6.65	8.04	25.85	462.0	
COS-250	5	2	20.00	69.00	52.60	9.49	8.20	8.55	26.30	536.0	

Nominal D.C.F.M. Capacity Rating

Refrigerant		COS-030	COS-070	COS-140	COS-205	COS-250
Group 1	R-717 (Ammonia), Natural Gas	30	70	140	205	250
Group 2	R-290 (Propane), R744 (Carbon Dioxide)	25	65	135	200	225
Group 3	R-22, R-23, R-407C, R-410A, R508B	20	50	105	150	180
Group 4	R-134A, R-404A, R507A, R-417A, R422D, R434A	19	45	95	140	160

For additional refrigerants or sizing information contact Technical Support at 1(800)-627-5148

OIL SEPARATORS

Coalescing - Replaceable Cartridges

The function of a Coalescing Oil Separator is to remove oil from the discharge gas and return it to the Compressor either directly or through an Oil Management System.

Applications

The Coalescing Oil Separators are typically used on larger industrial refrigeration systems and rely on a coalescing element to remove oil from the hot gas. Once the filtering element becomes saturated with oil it will begin accumulating within the vessel. An optional float valve can be attached to control oil flow to an Oil Management System or straight to a compressor crankcase.

Henry Technologies' Coalescing Oil Separators are suitable for use with Ammonia, HCFC and HFC refrigerants, and their associated oils, as well as other industrial fluids non-corrosive to steel.

Main Features

- ODS and Butt Weld refrigerant connections
- NPT oil connections
- Easily replaceable coalescing cartridge
- Designed specifically for reciprocating refrigeration compressors
- Five models available covering entire range of single stage and booster compressors
- Oil float valve assembly and shut off valves available as optional accessories
- Can be mounted horizontal or vertical



Technical Specifications

Maximum working pressure = 400 PSI (27.5 Bar)

Allowable operating temperature = -20°F to +230°F (-29°C to +110°C)

Henry Technologies' Coalescing Oil Separators are constructed in accordance with ASME Section VIII. Additionally, Coalescing Oil Separators are designed and registered for use in Canada. Please contact Technical Support at 1-800-627-5148 for CRN details and list of approved provinces and territories.

Materials of Construction

All pressure bearing components and connections are made of steel.

- 1 Inlet 2 Outlet 3 3/4" NPT Drain 4 1/2" NPT Relief Port 5 Horizontal Mount 6 Vertical Mount

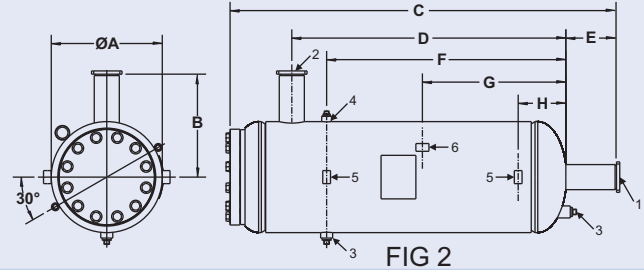
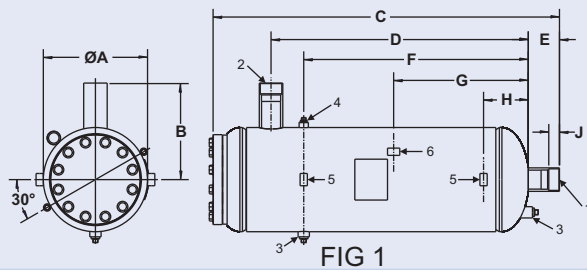

ODS CONNECTIONS

Part No	ODS (inch)	Fig No	Dimensions (inch)										Weight (lbs)
			ØA	B	C	D	E	F	G	H	J		
COSM-030F	2 1/8	1	8.63	9.81	32.07	22.87	4.82	19.71	14.46	6.21	1.37	138.0	
COSM-070F	2 5/8	1	12.75	11.75	42.35	31.47	3.82	27.47	16.47	5.47	1.31	379.0	
COSM-140F	3 1/8	1	16.00	14.00	52.56	38.04	5.46	30.54	20.10	6.66	1.69	566.0	

All ODS connection separators can be cut back to BW connections

BUTT WELD CONNECTIONS

Part No	BW (inch)	Fig No	Dimensions (inch)										Weight (lbs)
			ØA	B	C	D	E	F	G	H			
COSM-030	2	2	8.63	10.31	33.76	22.87	6.51	19.71	14.46	6.21	138.0		
COSM-070	2 1/2	2	12.75	11.82	44.38	31.47	5.82	27.47	16.47	5.47	379.0		
COSM-140	3	2	16.00	14.00	52.56	38.04	5.46	30.54	20.10	6.66	566.0		
COSM-205	4	2	18.00	16.00	70.06	49.91	8.27	44.41	27.54	8.04	773.0		
COSM-250	5	2	20.00	16.00	71.49	50.79	7.32	44.29	32.73	8.54	896.0		

Nominal D.C.F.M. Capacity Rating

Refrigerant		COSM-030	COSM-070	COSM-140	COSM-205	COSM-250
Group 1	R-717 (Ammonia), Natural Gas	30	70	140	205	250
Group 2	R-290 (Propane), R744 (Carbon Dioxide)	25	65	135	200	225
Group 3	R-22, R-23, R-407C, R-410A, R508B	20	50	105	150	180
Group 4	R-134A, R-404A, R507A, R-417A, R422D, R434A	19	45	95	140	160

For additional refrigerants or sizing information contact Technical Support at 1(800)-627-5148

OIL SEPARATORS

Screen Type

The function of a Screen Type Oil Separator is to remove oil from the discharge gas and return it to the Compressor either directly or through an Oil Management System.

Applications

Similar to the Coalescing Separators, Screen Type Oil Separators are typically used on larger industrial refrigeration systems. The stainless steel screen element offers a lower pressure drop compared to coalescing filters. Oil droplets are removed from the hot gas discharge by the stainless steel screen. The oil then drains and collects in the separator before being returned to the compressor. Henry Technologies' Screen Type Oil Separators are suitable for use with ammonia, HCFC and HFC refrigerants, and their associated oils, as well as other industrial fluids non-corrosive to steel.

Main Features

- ODS and Butt Weld refrigerant connections
- NPT oil connections
- Stainless steel 303 screen mesh filter media
- Oil float valve assembly and shut off valves available as optional accessories
- All welded design
- Lower pressure drop than coalescing models

Technical Specifications

Maximum working pressure = 400 PSI (27.5 Bar)

Allowable operating temperature = -20°F to +300°F (-29°C to +149°C)

Henry Technologies' Screen Type Oil Separators are constructed to ASME Section VIII. Additionally, Screen Type Oil Separators are designed and registered for use in Canada. Please contact Technical Support at 1-800-627-5148 for CRN details and list of approved provinces and territories.



CRN

Materials of Construction

All pressure bearing components and connections are made of steel. Filter element is made of stainless steel mesh.

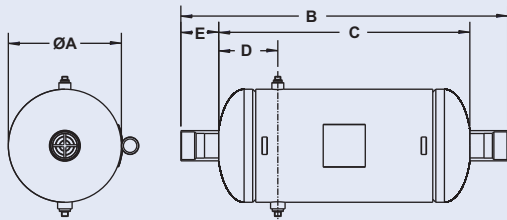

FIG 1

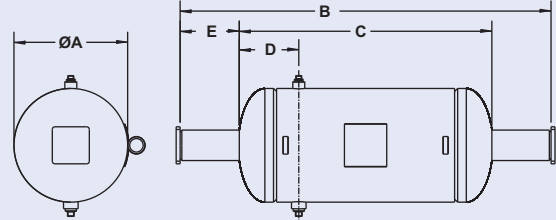

FIG 2

ODS CONNECTIONS*

Part No	ODS (inch)	Fig No	Rating in CFM**		Dimensions (inch)					Weight (lbs)
			Max	Min	ØA	B	C	D	E	
O-100F	2 1/8	1	100	20	6.63	31.0	23.75	5.06	3.62	38.0
O-175F	2 5/8	1	175	30	8.63	30.95	23.23	4.89	3.86	48.0
O-250F	2 5/8	1	250	50	10.75	31.08	23.88	5.62	3.60	76.0
O-350F	3 1/8	1	350	75	12.75	40.00	31.26	9.01	4.37	120.0

*All ODS connection separators can be cut back to BW connections

**Compressor Displacement in cubic feet per minute

BUTT WELD CONNECTIONS

Part No	BW (inch)	Fig No	Rating in CFM*		Dimensions (inch)					Weight (lbs)
			Max	Min	ØA	B	C	D	E	
O-100	2	2	100	20	6.63	35.0	23.75	5.06	5.62	40.0
O-175	2 1/2	2	175	30	8.63	32.75	23.25	4.89	4.75	54.0
O-250	2 1/2	2	250	50	10.75	35.08	23.88	5.62	5.60	81.0
O-350	3	2	350	75	12.75	42.00	31.26	9.01	5.37	124.0
O-650	4	2	650	100	14.0	44.61	31.89	9.47	6.36	162.0
O-900	4	2	900	150	16.0	52.00	44.00	15.5	4.00	218.0

*Compressor Displacement in cubic feet per minute

OIL RESERVOIRS

The function of an Oil Reservoir is to provide a holding charge of oil, as part of a Low Pressure Oil Management System.

Applications

The amount of oil circulating in a system varies depending on the operating conditions. The Oil Reservoir caters to these fluctuations by providing additional storage capacity. Rotalock Valves are supplied with each reservoir to facilitate easy oil fill and drain. A connection is provided at the top of the unit for fitting a Reservoir Pressure Valve. Depending on size, models are provided with either two or three sight glasses for visual indication of oil level. The standard range of reservoirs is suitable for use with HCFC and HFC refrigerants, and their associated oils, as well as other industrial fluids non-corrosive to steel, copper and Teflon.

Main Features

- SAE flare Rotalock valve connections
- Robust construction
- SAE flare connection for Reservoir Pressure Valve
- Sight glass with floating ball
- Supplied with mounting brackets

Technical Specifications

Maximum working pressure = 450 PSI (31 Bar)

Allowable operating temperature = +15°F to +250°F (-10°C to +121°C)

Henry Technologies' Oil Reservoirs are UL and C-UL Listed by Underwriters Laboratories, Inc. Additionally, Oil Reservoirs are designed and registered for use in Canada. Please contact Technical Support at 1-800-627-5148 for CRN details and list of approved provinces and territories.

Materials of Construction

The shell, end caps and fitting connections are made from carbon steel.



Selection Guidelines

Larger systems or compressors that discharge more oil should use a 4 gallon reservoir. It is possible to pipe two identical reservoirs in parallel to increase the holding capacity. The oil lines attach to the valves at the top and bottom should be feed together. Selecting a size depends on customer preference.

Installation - Notes

Full instructions are given in the Oil Level Control Manual, included with each reservoir.

- ❶ 3/8 SAE Flare Inlet
- ❷ 3/8 SAE Flare Outlet
- ❸ 3/8 SAE Flare Reservoir Pressure Valve Connection

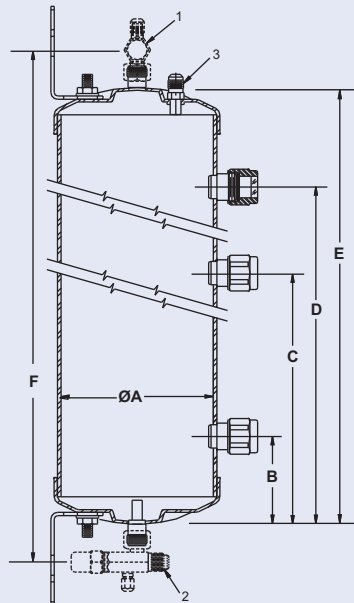

FIG 1

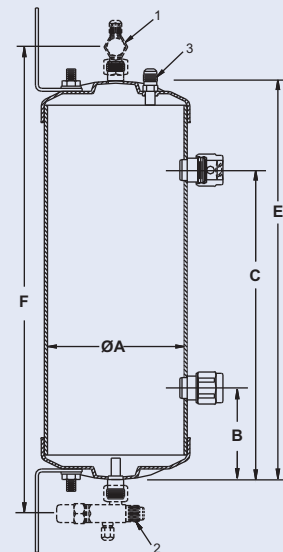

FIG 2

Part No	Fig No	Capacity (gallons)	Dimensions (inch)						Weight (lbs)
			ØA	B	C	D	E	F	
S-9108	1	4	6.0	6.51	18.76	31.01	34.76	37.98	19.84
S-9108U	2	3	6.0	6.50	22.00	N/A	25.75	28.98	27.56
S-9109	2	2	6.0	6.59	13.09	N/A	16.93	19.98	33.07

RESERVOIR PRESSURE VALVES

The function of a Reservoir Pressure Valve is to vent excess pressure to the suction line in order to maintain a positive pressure differential between the Oil Reservoir and Compressor.

Applications

A Reservoir Pressure Valve is used in a Low Pressure Oil Management System. It is used to vent pressure in the Oil Reservoir while still maintaining a positive pressure differential between the Oil Reservoir and the compressor crankcase. This positive pressure ensures an adequate oil supply to the Oil Level Regulators. The inlet of the valve should be connected directly to the Oil Reservoir and the outlet should be piped to suction pressure.

Reservoir Pressure Valves are suitable for use with HCFC and HFC refrigerants, and their associated oils, as well as other industrial fluids non-corrosive to brass, steel and Teflon.

Main Features

- Proven design
- SAE flare connections
- Two different pressure settings
- Premium quality Teflon seal

Technical Specifications

Maximum working pressure = 500 PSI (34.5 Bar)

Allowable operating temperature = +15°F to +250°F (-10°C to +121°C)

The Reservoir Pressure Valves are USR and CNR recognized by Underwriters Laboratories, Inc.

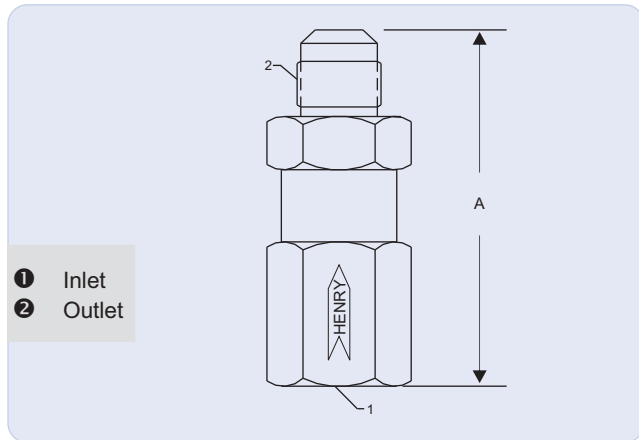

Materials of Construction

The valve body components are made from brass, the spring from stainless steel and the seal from Teflon.

Selection guidelines

The S-9104 and S-9104H models provide 5 lbs. and 20 lbs. pressure differential respectively

A higher pressure differential will increase the oil flow rate from the Oil Reservoir back to the compressors.

The user should select a model taking into account individual compressor crankcase pressures along with the differential pressure range of the Oil Regulators.

Multiple Reservoir Pressure Valves may be installed in series for additional pressure requirements. Example: Installing (2) S-9104 Reservoir Pressure Valves would create a 10 PSI (0.7 Bar) differential.

Part No	Pressure Setting (lbs)	Conn Size (Inch)		Dimensions (inch)	Weight (lbs)
		Inlet	Outlet	A	
S-9104	5	3/8 SAE Flare Female	3/8 SAE Flare Male	2.51	0.29
S-9104H	20	3/8 SAE Flare Female	3/8 SAE Flare Male	2.51	0.29

INFRA-RED OIL CONTROLLER I-ROC-LV

The function of the Infra-Red Oil Controller is to control the oil level in the compressor crankcase using proven optical sensor technology.

Applications

The I-ROC-LV Oil Regulator can be used with Low and High Pressure Oil Management Systems on a single compressor or on multi-compressor racks. The I-ROC-LV Oil Regulator is fitted to the sight glass housing of the compressor and has an integral sight glass that allows visual inspection of the crankcase oil level. The regulator comes ready to mount to several popular compressors using the 3 or 4 bolt, 1-7/8" BC, universal flange. Oil Level Regulator Adapter Kits are available for additional applications. The I-ROC-LV Oil Regulators are suitable for use with ASHRAE 34 Class A1 refrigerants and their associated oils, as well as other industrial fluids non-corrosive to aluminum, steel, brass, and synthetic rubber.

Main Features

- Patented optical sensor technology*
- Universal flange compressor connection
- SAE flare oil connection
- Fixed oil level control at 1/2 sight glass
- Low level alarm circuit
- Replacement parts available
- Adapters available for most popular compressor models

How it works

The oil is regulated at 1/2 Sight Glass using variable pulse timing. When a low oil condition is detected, oil begins to pulse into the compressor at the time intervals shown in the Operation Table. As the duration of oil filling increases, the oil pulse time increases to better meet the oil demand. If demand is not satisfied after 2 minutes of continuous oil feed, a low level alarm is initiated by means of a fail-safe electrical contact. During the alarm condition the regulator will continue to pulse feed oil. The alarm will reset automatically if the oil returns to 1/2 glass. The alarm contact may be used to shut down the compressor in the event of a low level condition.

Technical Specifications

Max working pressure: 650 PSI (45 Bar)
 Max differential pressure: 350 PSI (24 Bar)
 Max ambient temp: 140°F (60°C)
 Max fluid temp: 176°F (80°C)
 Supply voltage: 24V, 60HZ
 Operating current: 0.6 Amps@24V
 Alarm contact rating: 5A@240VAC, SPDT

Henry Technologies' I-ROC-LV Oil Level Controller meets the requirements of UL 429 and is USR and CNR recognized by Underwriters Laboratories, Inc.

Materials of Construction

The valve body is made of aluminum. The inlet connection is made of brass. The outlet adapter is made of plated steel and the electronics enclosure is made of molded plastic.

Installation - Notes

1. To protect the Oil Level Regulator from system debris, an Oil Strainer, Oil Filter or Oil Filter Drier is recommended.
2. The operating differential oil pressure should be within the range of the Regulator's specification.
3. The 1/2 sight glass oil level must be in line with the compressor manufacturer's guidelines.
4. If the alarm output is used to shut down a compressor, an external time delay should be fitted into the circuit.
5. The electronic module will be damaged if the 24V supply voltage is exceeded.
6. Power to the unit should be maintained during compressor running, stand-by and shutdown modes.
7. Full instructions are given in the Product Instruction Sheet included with each Regulator.

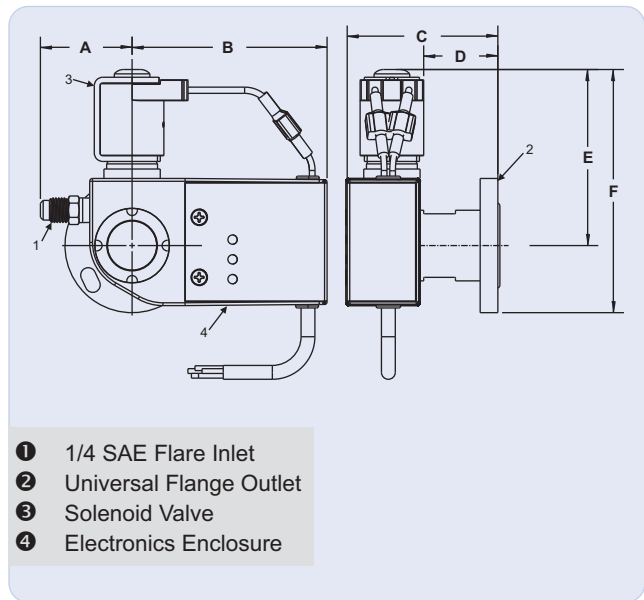

- 1 1/4 SAE Flare Inlet
- 2 Universal Flange Outlet
- 3 Solenoid Valve
- 4 Electronics Enclosure

Part No	Dimensions (inch)						Weight (lbs)
	A	B	C	D	E	F	
OP-03-1/2	1.62	3.45	2.69	1.31	3.12	4.30	1.3

OPERATION TABLE				
Oil Level	Oil Fill Duration	Oil Fill Pulse Timing	Oil LED	Alarm
Good	N/A	No oil flow	Solid	No
Low	0 - 60 seconds	1.0 sec ON/1.8 sec OFF	Blinking	No
Low	61 - 120 seconds	2.0 sec ON/2.0 sec OFF	Blinking	No
Low	120+ seconds	3.0 sec ON/3.0 sec OFF	Blinking	Yes

ELECTRO-MECHANICAL OIL LEVEL REGULATOR

The function of an Electro-Mechanical Oil Level Regulator is to control the oil level in the compressor crankcase when used as part of a Low or High Pressure Oil Management System.

Applications

Electro-Mechanical Oil Level Regulators can be used with Low and High Pressure Oil Management Systems on a single compressor or on multi-compressor racks. The S-9030 Regulators is designed to bolt directly to the sight glass housing on the compressor crankcase. Henry Technologies offers a wide variety of Adapters to allow use on most popular compressor models.

The S-9030 Electro-Mechanical Oil Level Regulator can be adjusted to maintain an oil level between 1/4 and 1/2 sight glass. The S-9030 maintains the oil level at any pressure differential between 5 and 300 PSI (0.35 and 20.7 Bar).

The Henry Technologies' Electro-Mechanical Oil Level Regulator is suitable for use with HFC and HCFC refrigerants and their associated oils, as well as other industrial fluids non-corrosive to steel, brass, copper, and Teflon.

Main Features

- Patented Henry Technologies' Design*
- 3 Bolt, 1-7/8" BC Compressor Connections
- SAE flare oil and equalization connections
- Supply = 24 VAC, 6 Watt
- Adjustable oil level between 1/4 and 1/2 sight glass
- Low level alarm circuit
- Replacement parts available for all major components
- Pressure equalization ports for multi compressor applications
- Adapters available for most popular compress models

Technical Specifications

Maximum Working Pressure = 450 PSI (31 Bar)

Allowable Pressure Differential = 5 to 300 PSI (0.35 to 20.7 Bar)

Allowable Operating Temperature = -14°F to +212°F (-10°C to +100°C)

Henry Technologies' Electro-Mechanical Oil Level Regulator is UL and C-UL Listed by Underwriters Laboratories, Inc.

Materials of Construction

The shell and caps are made of steel. All connections are made of plated steel, and the protective cap is made of vinyl.

Installation - Notes

1. To protect the Oil Level Regulator from system debris, an Oil Strainer, Oil Filter or Oil Filter Drier is recommended.
2. The Oil Level Regulator should not be subjected to excessive vibration.
3. The operating differential oil pressure should be within the range of the Regulator's specification.
4. The oil level must be set and controlled in line with the compressor manufacturer's guidelines.
5. If the alarm output is used to shut down a compressor, an external time delay should be fitted into the circuit.
6. Full instructions are given in the Product Instruction Sheet included with each Regulator.

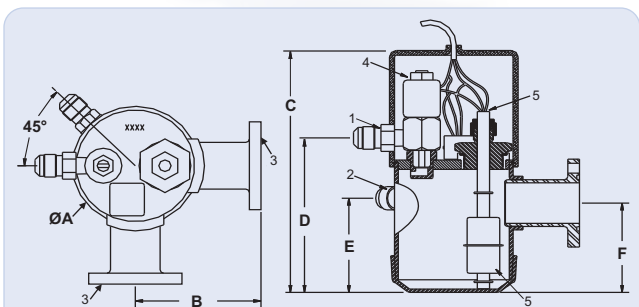

- 1 3/8 SAE Flare Inlet
- 2 3/8 SAE Equalization Port
- 3 3-Bolt Flange
- 4 Solenoid Valve
- 5 Float Switch

Part No	Dimensions (inch)						Weight (lbs)
	ØA	B	C	D	E	F	
S-9030	3.0	3.18	6.5	4.15	2.53	2.4	4.0

REPLACEMENT PART TABLE	
Part No	Description
3-044-016	Float Switch
3-047-017	Solenoid Valve Kit

MECHANICAL OIL LEVEL REGULATORS

The function of a Mechanical Oil Level Regulator is to control the oil level in the compressor crankcase when used as part of a Low Pressure Oil Management System.

Applications

Oil Level Regulators are typically used as part of a Low Pressure Oil Management System on parallel compressor racks. Mechanical Oil Level Regulators are designed to bolt directly to the sight glass housing on the compressor crankcase. Henry Technologies offers fixed level and adjustable level Oil Level Regulators, as well as a wide variety of Adapters to allow use on most popular compressor models.

The S-9010 Mechanical Oil Level Regulator maintains a fixed oil level at 1/2 sight glass. The S-9010 maintains the oil level at any pressure differential between 5 and 30 PSI (0.35 to 2.0 Bar)

The S-9090 Mechanical Oil Level Regulator can be adjusted to maintain an oil level between 1/4 and 5/8 sight glass. The S-9090 maintains the oil level at any pressure differential between 5 and 90 PSI (0.35 and 6.2 Bar). Henry Technologies' exclusive design allows for oil level adjustment while the system is in operation eliminating the need of system shut down or disconnection of oil supply lines.

The S-9130 Mechanical Oil Level Regulator can be adjusted to maintain an oil level between 1/4 and 5/8 sight glass. The S-9130 maintains the oil level at any pressure differential between 5 and 90 PSI (0.35 and 6.2 Bar). Henry Technologies' exclusive design allows for oil level adjustment while the system is in operation eliminating the need of system shut down or disconnection of oil supply lines.

All Henry Technologies' Mechanical Oil Level Regulators are suitable for use with HFC and HCFC refrigerants and their associated oils, as well as other industrial fluids non-corrosive to steel, brass, copper, nylon and synthetic rubber.

Main Features

- 3 bolt on 1-7/8" or universal flange compressor connections
- SAE flare oil and equalization connections
- Adjustable oil level on select models
- Pressure equalization ports for multi compressor applications
- Adapters available for most popular compress models

Technical Specifications

Maximum working pressure = 450 PSI (31 Bar)

Allowable pressure differential S-9010 = 5 to 30 PSI (0.35 to 2.0 Bar)

Allowable pressure differential S-9090 & S-9130 = 5 to 90 PSI (0.35 to 6.2 Bar)

Allowable operating temperature = +32°F to +266°F (0°C to +130°C)

Henry Technologies' Mechanical Oil Level Regulators are UL and C-UL Listed by Underwriters Laboratories, Inc.



Materials of Construction

The shell and caps are made of steel. The float valve is made of brass with a stainless steel needle. The float ball is made of stainless steel and all connections are made of plated steel.

Installation - Notes

1. To protect the Oil Level Regulator from system debris, an Oil Strainer, Oil Filter or Oil Filter Drier is recommended.
2. The Oil Level Regulator can be fitted directly to 2, 3 and 4 cylinder compressors and to most 6-cylinder compressors that use a standard 3 or 4 bolt sight glass. For other compressor configurations, an adaptor will be required.
3. The Oil Level Regulator should not be subjected to excessive vibration. The operating differential oil pressure should be within the range of the Regulator's specification.
4. The oil level must be set and controlled in line with the compressor manufacturer's guidelines.
5. Full instructions are given in the Product Instruction Sheet included with each Regulator.

- ❶ 3/8 SAE Flare Inlet ❸ Compressor Connection Flange
❷ 3/8 SAE Equalization Port ❹ Adjustment Screw

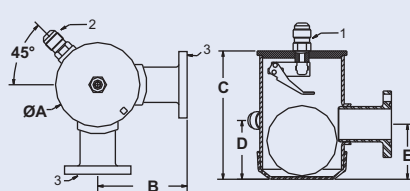

FIG 1

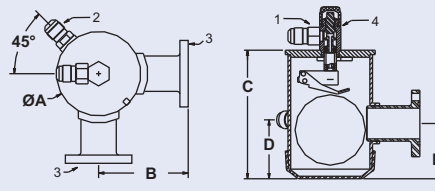

FIG 2

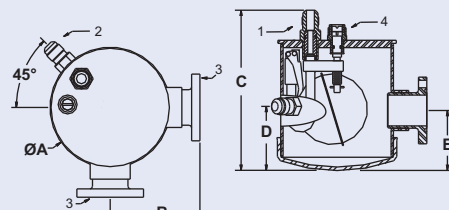

FIG 3

Part No	Fig No	Dimensions (inch)					Flange Type	Weight (lbs)
		ØA	B	C	D	E		
S-9010	1	3.0	3.18	4.56	2.09	1.96	3 on 1-7/8"	3.2
S-9090	2	3.0	3.18	4.56	2.09	1.96	3 on 1-7/8"	3.3
S-9130	3	4.0	3.18	4.55	2.25	2.12	Universal Flange	3.9

OIL REGULATOR ADAPTER KITS

The function of an Oil Regulator Adapter Kit is to allow Mechanical, Electro-Mechanical, and Optronic Oil Level Regulators to be installed on most popular compressor models.

Applications

Due to various compressor sight glass configurations, Henry Technologies offers several adapter kits to install Oil Level Regulators. The Standard Adapter Kit (3-033-201) is included with all Mechanical and Electro-Mechanical Oil Level Regulators. Included in the 3-033-201 kit is (2) O-Rings, one Quad Ring, Bolts, and Nuts. All adapters with sight glass patterns different from 3 Bolt 1-7/8" BC also include the standard adapter kit. Oil Regulators Adapter Kits are suitable for use with HFC and HCFC refrigerants and their associated oils, as well as other industrial fluids non-corrosive to steel, copper, and synthetic rubber.

Materials of Construction

Although construction varies, all adapters are made from carbon steel. The O-Rings are made of Neoprene and hardware is made from Grade 5 Steel.

Installation - Notes

1. Do NOT operate ANY Oil Level Regulator at 1/4 sight glass when using an adapter with an inside diameter smaller than the Oil Level Regulator flange port.
2. Oil Level Regulator installation should follow requirements of compressor manufacturers where applicable.
3. Full Instructions are provided in the Product Instruction Sheet included with each Adapter Kit.

Compressor Manufacturer	Model Number	Recommended Oil	Sight Glass Configuration	Henry Technologies Kit Number
Bitzer	-	1/2 Glass	4 bolt 50mm BC	3-033-253
Bock	AM,F	1/2 Glass	4 bolt 1 31/32" BC	3-033-244
Bristol	-	1/2 Glass	15/16" -20 Thread	3-033-242
Carrier Carlyle	10 hp & under: DA, DR, 5F, 06D, 06CC	1/4 Glass	1 1/2" -18 Thread	3-033-204
Carrier Carlyle	15 hp & over: EA, ER, 06E, 06CC	1/4 Glass	3 bolt 1 7/8" BC	3-033-201
Copeland	Under 5 tons: Copelametic HA,KA,EA,3A,LA,ER,3R	1/2 Glass	1 1/8" -12 Thread	3-033-202
Copeland	Discus,2D,3D,4D,6D,9D,4R,6R,9D,9R,MD,MR,NR	1/4 Glass	3 bolt 1 7/8" BC	3-033-201
Copeland	Older Model	1/4 Glass	4 bolt 2 1/8" BC	3-033-207
Copeland	8R,8D	1/4 Glass	3 bolt 1 7/8" BC	3-033-212
Copeland	8DP3	1/4 Glass	3 bolt 1 7/8" BC	3-033-254
Copeland	Scroll	1/2 Glass	3/4" NPT	3-033-218
Dunham-Bush	Big 4	1/2 Glass	3 bolt 1 7/8" BC	3-033-201
Dunham-Bush	D	1/2 Glass	4 bolt 2 1/8" BC	3-033-203
Frascold	All models	1/2 Glass	3 bolt 1 7/8" BC	3-033-201
Grasso Thermtrol	-	1/2 Glass	1" NPT	3-033-228
Maneurop	All models	1/2 Glass	1 1/8" -18 Thread	3-033-246
Prestcold	K	1/2 Glass	1 1/8" -12 Thread	3-033-202
Prestcold	C,E,R,L,LG	1/2 Glass	42mm Thread	3-033-216
Schnacke-Grasso	-	1/2 Glass	2" -16 Thread	3-033-205
Schnacke-Grasso	-	1/2 Glass	1 1/4" NPT	3-033-219
Tecumseh	P,R,S,PA,RA,SA,CK,CM,CH,CG	1/2 Glass	1 1/8" -12 Thread	3-033-202
Trane	M,R	1/2 Glass	3 bolt 1 7/8 BC	3-033-201
Trane	-	1/2 Glass	5 bolt 2 1/8 BC	3-033-206
Trane	K	1/2 Glass	3/4" NPT	3-033-218
Vilter	-	1/2 Glass	1 1/2" NPT	3-033-208
Vilter	-	1/2 Glass	2" NPT	3-033-209
York	GC,GS,JS	1/2 Glass	3 bolt 1 7/8 BC	3-033-201
York	-	1/2 Glass	1" NPT	3-033-228

OIL LEVEL COMPONENTS

Universal Adaptor Kits and Valves

UNIVERSAL ADAPTER KITS

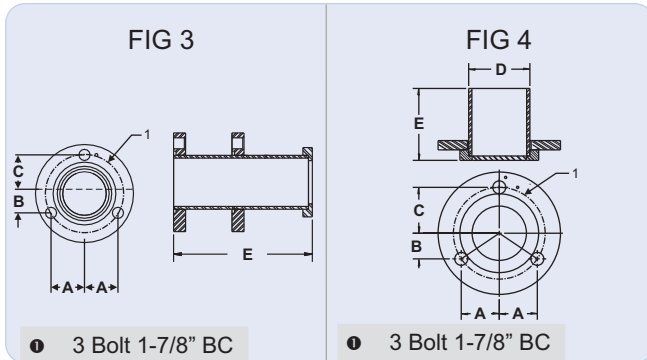
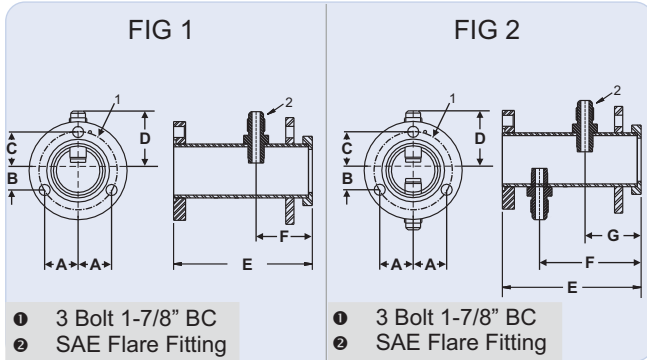

Part No	Description	Fig No	Dimensions (inch)						
			A	B	C	D	E	F	G
3-033-226	Equalization	1	0.777	0.524	0.937	1.38	3.22	1.31	N/A
3-033-221	Double 1/4 SAE Flare Equalization	2	0.777	0.524	0.937	1.38	3.22	2.00	1.31
3-033-227	Double 3/8 SAE Flare Equalization	2	0.777	0.524	0.937	1.75	3.23	2.00	1.31
3-033-212	Short Extension	3	0.777	0.524	0.937	N/A	2.59	N/A	N/A
3-033-254	Long Extension	3	0.777	0.524	0.937	N/A	3.25	N/A	N/A
3-033-217	Universal Adapter	4	0.777	0.524	0.937	1.25	1.91	N/A	N/A

Applications

Henry Technologies offers a number of universal Equalization and Extension Adapter Kits for use in applications where Standard Adapter Kits will not work. The Equalization Adapter Kits include SAE flare fittings to allow non-equalized Oil Level Regulators to be interconnected (equalized). Extension Adapters are available if extra clearance is needed between the Oil Level Regulator and Compressor. All Universal Adapter Kits are suitable for use with HFC and HCFC refrigerants and their associated oils, as well as other industrial fluids non-corrosive to steel, copper, and synthetic rubber.

Technical Specifications

Maximum working pressure = 450 PSI (31 Bar)
Allowable operating temperature = 14°F to +212°F (-10°C to +100°C)

Materials of Construction

All adapters are made from carbon steel. The O-Rings are made of Neoprene and hardware is made from Grade 5 Steel.

Installation - Notes

- Do NOT operate ANY Oil Level Regulator at 1/4 sight glass when using an adapter with an inside diameter smaller than the Oil Level Regulator flange port.
- Oil Level Regulator installation should follow requirements of compressor manufacturers where applicable.
- Full Instructions are provided in the Product Instruction Sheet included with each Adapter Kit.

SHUT-OFF BRASS VALVES

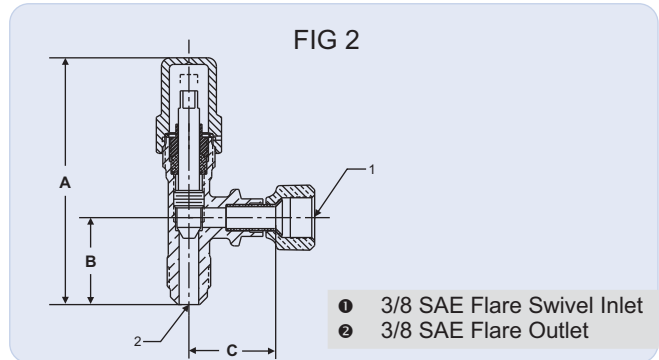
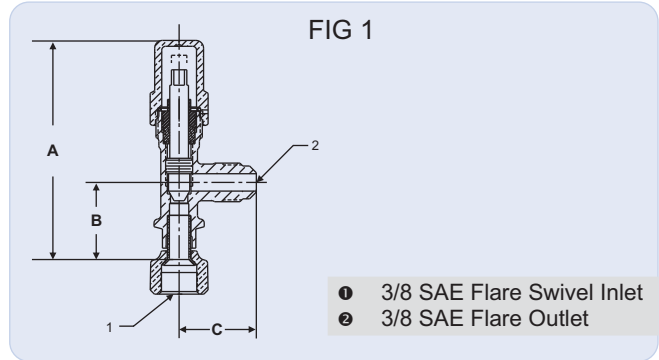

Part No	Fig No	Dimensions (inch)			Weight (lbs)
		A	B	C	
S-9106V	1	3.55	1.25	1.25	0.45
S-9106H	2	3.55	1.25	1.25	0.45

Applications

Henry Technologies' Brass Shut-off Valves are offered in vertical and horizontal configurations. Both configurations are designed to mount on oil inlet connections and equalization line connections of Oil Level Regulators and Oil Separator return fittings. The valves allow each Oil Level Regulator to be isolated if service is required on a Compressor, Oil Level Regulator, Oil Filter, Oil Filter-Drier, or Oil Strainer. The inlet of each valve has a female swivel SAE flare connection which allows 360° positioning of the male SAE flare connection for most convenient mounting of oil or equalization lines. Henry Technologies' Brass Shut-off Valves are suitable for use with HFC and HCFC refrigerants and their associated oils, as well as other industrial fluids non-corrosive to steel, brass, copper and nylon.

Technical Specifications

Maximum working pressure = 450 PSI (31 Bar)
Allowable operating temperature = 14°F to +212°F (-10°C to +100°C)

Materials of Construction

The valve body is made of brass. The stem is made from steel. The swivel connection is made from brass and copper and the seal cap is made from brass.

ACCESSORIES AND REPLACEMENT COMPONENTS

OIL SEPARATOR COMPONENTS

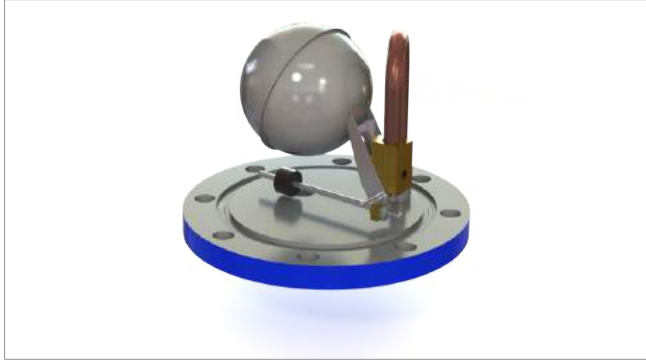

Henry Technologies offers various replacement components for the oil separators. After an extended service life, they may need to be replaced due to wear and the collection of system debris with the small flow orifices.

The below chart shows all the available replacement parts for Henry Technologies' Oil Separators.

Vessel Part No	Float Assembly*	Gasket**	Brass Screens***	Filter Cartridge
S-5290	A-1900-30	2-023-001	N/A	N/A
S-5292				
S-5294				
S-5202				
S-5203				
S-5204				
S-1901	A-5700-30	2-023-001	3-010-306	3-010-301
S-1902			3-010-307	
S-1903			3-010-308	
S-1904			3-010-309	
S-5792	A-5700-30	2-023-001	N/A	3-010-301
S-5794				
S-5882	A-5000-30	2-023-001	N/A	N/A
S-5885				
S-5887				
S-5888				
S-5890				
COSM-030	N/A	2-023-087	N/A	2-043-056
COSM-070		2-023-088		2-043-055
COSM-140		2-023-089		2-043-054
COSM-205		2-023-089		2-043-070
COSM-250		2-023-119		2-043-071

*Float assemblies available with optional 3/8" ODS oil return connection by ordering with and "x" suffix (i.e. A-1900-30X)

**Gasket included with replacement float assembly

***Replacement screens are difficult to replace

EXTERNAL OIL FLOAT



Henry Technologies offers the SN-9142 External Oil Float as an optional accessory for Oil Management Systems. The SN-9142 is suitable for use with ammonia, HCFC and HFC refrigerants and their associated oils, as well as other industrial fluids non-corrosive to steel. The 7771 Shut-Off Valve can be used on the float outlet to allow oil return line isolation.

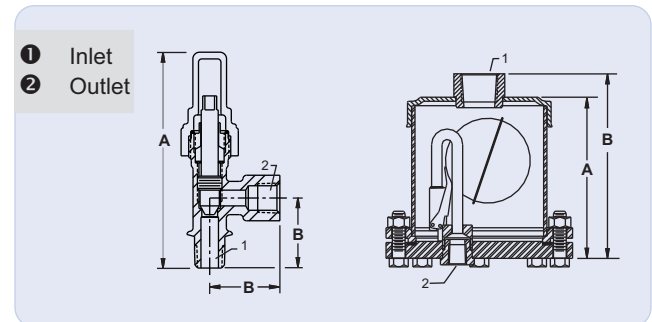

Part No	Description	Inlet NPT (inch)	Outlet NPT (inch)	Dimensions (inch)	
				A	B
SN-9142	Oil Float Valve	3/4	1/4	4.75	5.44
SN-9140-30	Replacement Float	N/A	1/4	N/A	N/A
7771	Shut-Off Valve	1/4	1/4	3.85	1.25

SIGHT GLASS COMPONENTS

3-BOLT SIGHT GLASSES

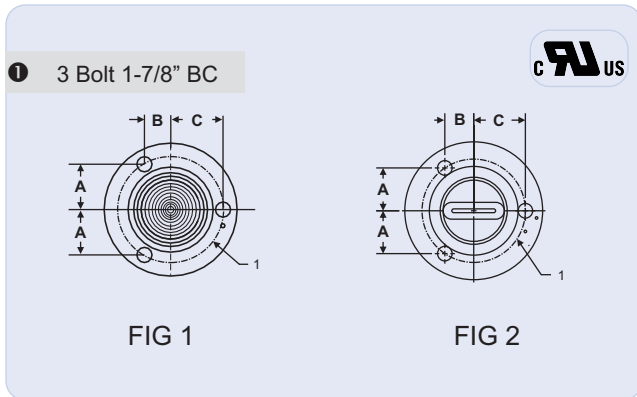

Part No	Fig No	Dimensions (inch)		
		A	B	C
2-020-006	1	0.777	0.524	0.937
SG-1300	2	0.777	0.524	0.937

Applications

Henry Technologies offers two styles of 3-bolt Sight Glasses for use on compressor crankcases or Mechanical and Electro-Mechanical Oil Level Regulators. The Sight Glasses are available with a Reflex Lens or a Prism Lens. The Reflex Lens is designed to allow easier fluid level inspection by appearing dark when liquid is present and light when liquid is absent. Similarly, the Prism Lens will appear as a bright double line under partial fluid level and completely disappear under full fluid contact.

Henry Technologies' replacement Sight Glasses are suitable for use with ammonia, HFC and HCFC refrigerants and their associated oils, as well as other industrial fluids non-corrosive to steel, glass and synthetic rubber.

Technical Specifications

Maximum working pressure = 500 PSI (34.4 Bar)
Allowable operating temperature = -20°F to +300°F (-29°C to +149°C)

Henry Technologies' Sight Glasses are USR and CNR recognized by Underwriters Laboratories, Inc.

Materials of Construction

All Sight Glasses feature a plated steel body with hermetically sealed soda lime glass lens.

Installation - Notes

1. Full instructions are given in the Product Instruction Sheet, included with each Sight Glass.

THREADED SIGHT GLASSES

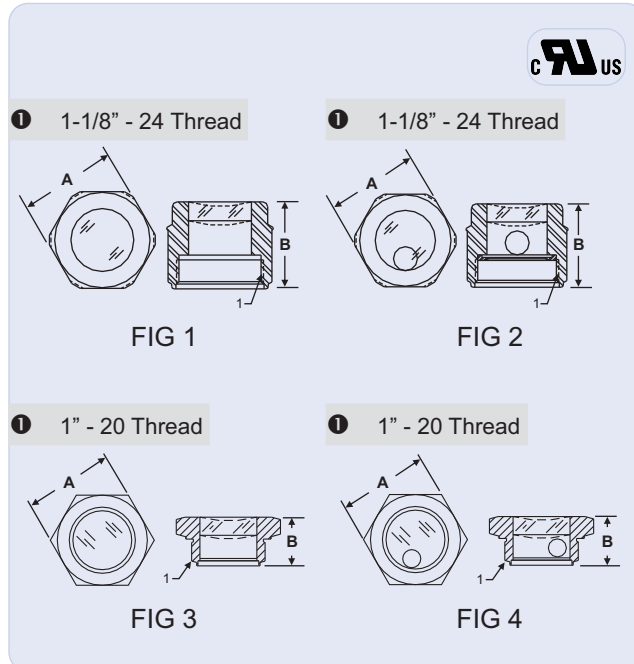

Part No	Fig No	Gasket Part No	Dimensions (inch)	
			A (hex)	B
3-020-052	1	2-023-019	1.25	1.13
3-020-053	2	2-023-019	1.25	1.13
3-020-010	3	2-023-005	1.25	0.67
3-020-011	4	2-023-005	1.25	0.67

Applications

Henry Technologies offers two styles of threaded Sight Glasses for replacement components on Oil Reservoirs and Oil Separator-Reservoirs. The male threaded design was used until May 1988 and the Female threaded design has been used from May 1988 to present. Both designs are currently available as replacement parts.

The Sight Glasses are available with a Clear Lens or Clear Lens with Float Ball. The Clear Lens design allows for unobstructed visual inspection of fluid level. The Float Ball series is designed to provide easier inspection of fluid level. The standard Float Ball is made of TPX plastic and will float in an fluid with a specific gravity greater than 0.85.

Henry Technologies' replacement Sight Glasses are suitable for use with HFC and HCFC refrigerants and their associated oils, as well as other industrial fluids non-corrosive to steel, glass and TPX Plastic.

Technical Specifications

Maximum working pressure = 500 PSI (34.4 Bar)
Allowable operating temperature = -20°F to +300°F (-29°C to +149°C)

Henry Technologies' Sight Glasses are USR and CNR recognized by Underwriters Laboratories, Inc..

Materials of Construction

All Sight Glasses feature a plated steel body with hermetically sealed soda lime glass lens. The Float Balls are made of TPX plastic.

OIL FILTERS AND OIL FILTER-DRIERS

The function of an Oil Filter is to remove system debris from the refrigerant oil to protect the Compressor and other Oil Management System components from damage. In addition to removing debris, the Oil Filter-Drier also removes moisture from the refrigerant oil.

Applications

Henry Technologies' Oil Filters and Oil Filter-Driers can be used in both Low and High Pressure Oil Management Systems. The unique drying features of the S-4005 model are particularly suited for systems using POE oil. This type of oil is more hydroscopic than mineral oil. This means that POE oil absorbs moisture at a much higher rate. Moisture in a refrigeration system can produce problems and/or harmful conditions. One S-4004 or S-4005 model can be fitted in the oil return line between the Oil Separator and Oil Reservoir, instead of fitting one Oil Strainer per Oil Level Regulator. These models will also remove more debris than traditional oil strainers. Henry Technologies' Oil Filters and Oil Filter-Driers are suitable for use with HFC and HCFC refrigerants and their associated oils, as well as other industrial fluids non-corrosive to steel and copper.

Main Features

S-4004 model

- High flow capacity with low pressure drop
- 475 in² filter area
- Particle retention down to 10 microns
- Suitable replacement for individual Oil Strainers on oil return lines capacity with low pressure drop

S-4005 model

- High flow capacity with low pressure drop
- 465 in² filter area
- Particle retention down to 6 microns
- High level of drying with 8in³ XH-9 desiccant
- Suitable replacement for individual Oil Strainers on oil return line

Technical Specifications

Maximum working pressure = 450 PSI (31 Bar)

Allowable operating temperature = 14°F to +212°F (-10°C to +100°C)

Materials of Construction

All pressure bearing components including shell, caps, and connection fittings are made of carbon steel. The internal spring is made of steel and the O-ring is made of synthetic rubber.

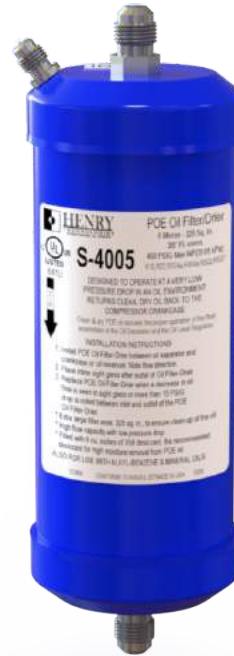

Installation - Notes

1. The Oil Filters and Oil Filter-Driers must be installed in accordance with the flow direction arrow.
2. Units should be replaced after a 15 PSI (1 Bar) pressure drop has been detected. It is recommended to install valves on either side of the filter to ease replacement.
3. For Low Pressure Oil Management Systems, Oil Filters and Oil Filter-Driers should be located between the Oil Separator and Oil Reservoir not between the Oil Reservoir and the Oil Level Regulator.

- ① 3/8 SAE Flare Inlet
- ② 3/8 SAE Flare Outlet
- ③ 1/4 SAE Flare Schrader Fitting

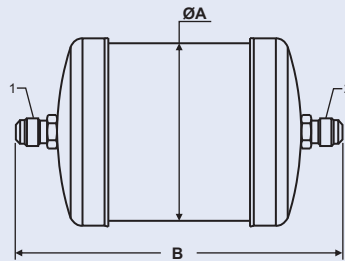

FIG 1

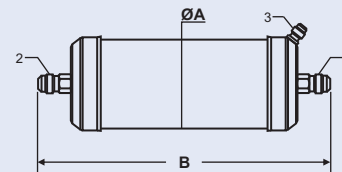

FIG 2

Part No	Fig No	Dimensions (inch)		Weight (lbs)
		ØA	B	
S-4004	1	4.0	7.39	3.45
S-4005	2	3.0	9.80	3.45

OIL STRAINER

The function of an Oil Strainer is to remove system debris from the refrigerant oil to protect the Compressor and other Oil Management System components from damage.

Applications

Henry Technologies' Oil Strainers can be used in both Low and High Pressure Oil Management Systems. Oil Strainers should be fitted in the oil return line between the Oil Reservoir and Oil Level Regulator. Henry Technologies' Oil Strainers are suitable for use with HFC and HCFC refrigerants and their associated oils, as well as other industrial fluids non-corrosive to steel and copper.

Main Features

- SAE Flare connections
- High flow capacity with low pressure drop
- 11 in² filter area
- Particle retention down to 150 microns

Technical Specifications

Maximum working pressure = 500 PSI (34.4 Bar)

Allowable operating temperature = -20°F to +300°F (-29°C to +149°C)

Henry Technologies' Oil Strainers are UL and C-UL Listed by Underwriters Laboratories, Inc.

Materials of Construction

The shell and caps are made of steel. The SAE flare connections are made of plated steel and the 100 mesh strainer cartridge is made of stainless steel.

Installation - Notes

1. The Oil Strainers must be installed in accordance with the flow direction arrow.
2. It is recommended to install valves on either side of the filter to ease replacement.

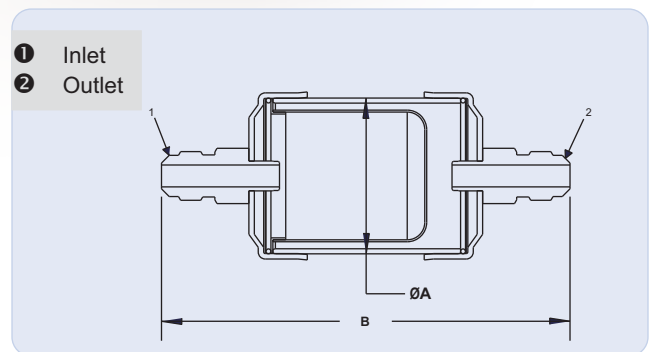

Part No	SAE Flare (inch)	Dimensions (inch)		Screen Area (in ²)	Weight (lbs)
		ØA	B		
S-9105	3/8	2.00	5.25	11.0	0.82

POSITIVE OIL EXCHANGE VALVES

The Positive Oil Exchange Valve is an efficient and timesaving servicing tool for the removal and replacement of compressor crankcase oil.

Applications

The valves are primarily intended for semi-hermetic type compressors. Positive Oil Exchange Valves are suitable for use with HCFC and HFC refrigerants, and their associated oils, as well as other industrial fluids non-corrosive to brass, steel, Teflon and nylon.

Main Features

- NPT compressor connections
- SAE flare oil connections
- SAE flare gauge connection with Schrader valve
- Easy to install
- Reduces service time and cost
- Designed for oil charge and drain
- Full port valve for fast charging and draining
- Designed to be permanently fitted to the compressor, for future servicing

Technical Specifications

Maximum working pressure = 500 PSI (34.5 Bar)

Allowable operating temperature = -20°F to +250°F (-29°C to +121°C)

Materials of Construction

The valve body is made from brass and the stem from plated steel. The stem seal cap is made from brass or nylon. The SAE Flare and Schrader port seal caps are made from nylon. The draw pipe is made from Teflon.

Installation - Notes

1. For safety reasons, the SAE Flare seal cap, complete with strap, should not be pressurized.
2. Full instructions are given in the Product Installation Sheet, included with each valve.

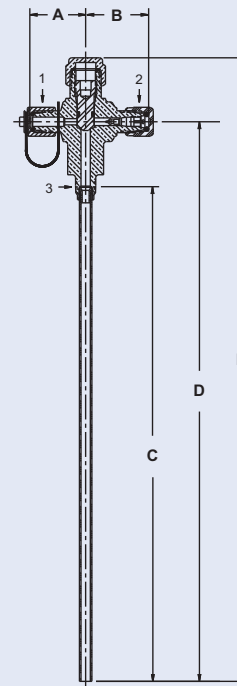

- ❶ Oil Inlet/Outlet
- ❷ Gauge Port
- ❸ Compressor Connection

Part No	Conn Size (inch)		Dimensions (inch)					Weight (lbs)
	Side	Bottom	A	B	C	D	E	
9297	1/4 SAE Flare	1/8 MPT	1.06	1.19	10.01	11.21	12.49	0.45
9298	1/4 SAE Flare	1/4 MPT	1.06	1.19	10.13	11.19	13.79	0.55

DISCHARGE LINE MUFFLERS

The function of a Discharge Line Muffler is to reduce pressure pulsations downstream of the Compressor.

Applications

The Muffler is designed to be installed directly after the compressor. Henry Technologies' Discharge Line Mufflers are suitable for use with HCFC and HFC refrigerants, and their associated oils, as well as other industrial fluids non-corrosive to steel and copper.

How it works

The Muffler reduces noise, due to gas pulsations, by allowing the gas to expand inside muffler chambers. Mufflers have internal baffles which are designed to dampen and smooth out low and high frequency compressor gas sound waves.

Main Features

- ODS connections
- Sound reduction
- Robust design
- Bi-directional flow

Technical Specifications

Maximum working pressure = 450 PSI (31 Bar)

Allowable operating temperature = +32°F to +250°F (0°C to +121°C)

Discharge Line Mufflers are UL and C-UL Listed by Underwriters Laboratories, Inc. Additionally, larger sized Discharge Line Mufflers can be CE marked in accordance with PED. See table below.

Materials of Construction

The main body and internal baffles are made from carbon steel. The connections are made from plated carbon steel.

Selection Guidelines

Select a muffler with a connection size that matches or exceeds the discharge line size. Larger mufflers will tend to remove more pulsations due to the larger internal volume.

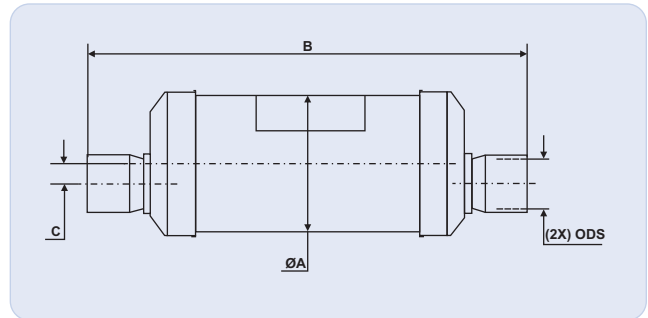

Part No	ODS (inch)	Dimensions (inch)			CE Cat*	Weight (lbs)
		ØA	B	C		
S-6304	1/2	3.0	7.75	0.75	SEP	2.34
S-6305	5/8	3.0	7.75	0.75	SEP	2.38
S-6307	7/8	3.0	9.69	0.44	SEP	2.76
S-6311	1 1/8	3.0	9.69	0.44	SEP	2.91
S-6405	5/8	4.0	6.75	0.94	SEP	3.57
S-6407	7/8	4.0	7.00	0.94	SEP	3.57
S-6411	1 1/8	4.0	12.75	0.94	CAT I	5.07
S-6413	1 3/8	4.0	13.75	0.94	CAT I	5.78
S-6415	1 5/8	4.0	18.25	0.75	CAT I	7.39
S-6621	2 1/8	6.0	21.00	1.25	CAT II	18.08
S-6625	2 5/8	6.0	21.00	1.00	CAT II	19.84
S-6631	3 1/8	6.0	22.38	0.75	CAT II	19.84

*Cat I and II CE models available by adding "-CE" suffix to the part number (i.e. S-6411-CE)

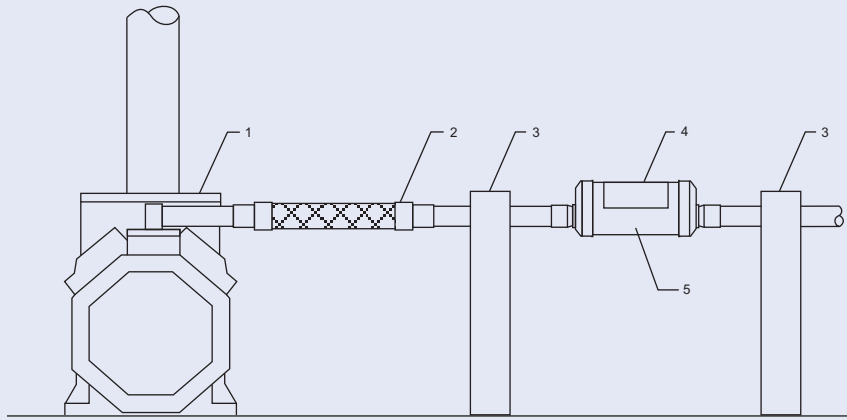

- ❶ Compressor
- ❷ Outlet ODS
- ❸ Support
- ❹ Muffler direction/orientation label
- ❺ Muffler

CORRECT MUFFLER SUPPORT

Installation - Notes

1. Install the Muffler as close as possible to the compressor and before the oil separator.
2. When mounted in a horizontal or angled position, the side with the label must be top center to help prevent oil collection inside the Muffler. Oil inside the Muffler will reduce the performance along with causing a loss of oil in the compressor crankcase. Positioning the Muffler at a slight angle so that the outlet port is below the inlet will also help prevent oil collection. Mufflers that are mounted vertically will not collect oil.
3. A Vibration Eliminator should be installed between the compressor and the Muffler to prevent transmitted vibration. The Muffler should be supported at each side to prevent discharge pipe vibration, due to the weight of the Muffler.
4. Mufflers will only remove noise due to discharge gas pulsations. If the noise is due to vibration, Vibration Eliminators should be added to the discharge line and possibly the suction line.
5. A single Muffler may be installed on a common discharge line. However, it is also acceptable to install one Muffler per compressor on parallel racks.

VIBRATION ELIMINATORS

The function of a Vibration Eliminator is to absorb compressor vibration to reduce the risk of damage to system equipment and pipework.

Applications

A Vibration Eliminator can be installed in both the suction and discharge lines of air-conditioning and refrigeration systems. Each unit is constructed of a deep pitch corrugated hose covered with a stainless steel braid. The hose and braid are reinforced by ferrules at each end and connected to copper tube ends by a high temperature braze alloy.

Vibration Eliminators are suitable for use with HCFC and HFC refrigerants and their associated oils, as well as other industrial fluids non-corrosive to stainless steel and copper.

Main Features

- ODS Connections
- Proven Design
- Large hose ID
- Stainless steel hose and braid
- Stainless steel ferrules for superior strength

Technical Specifications

Maximum working pressure = see table below

Allowable operating temperature = -40°F to +212°F (-40°C to +100°C)

Vibration Eliminators are USR and CNR recognized by Underwriters Laboratories, Inc. Additionally, Vibration Eliminators 1-3/8" and larger are CE marked in accordance with PED.



Materials of Construction

Each model consists of a stainless steel corrugated hose covered with a stainless steel braid. The ferrules are stainless steel and the tube ends are made from copper.

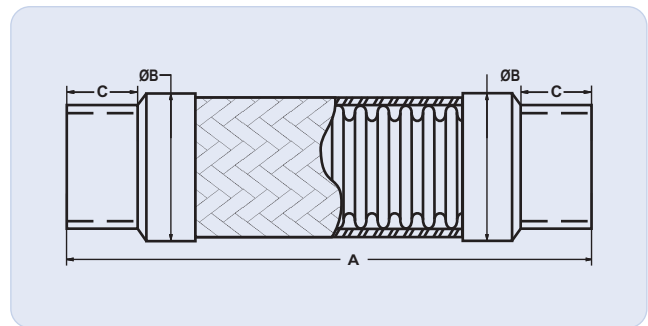

Part No	ODS (inch)	Dimensions (inch)			MWP (PSI/Bar)	Weight (lbs.)	CE Category
		A	ØB	C			
V-1/4	1/4	8.0	0.6	0.7	500/34.5	0.15	SEP
V-3/8	3/8	8.6	0.7	0.7	500/34.5	0.26	SEP
V-1/2	1/2	9.0	0.9	0.7	500/34.5	0.31	SEP
V-5/8	5/8	9.9	1.0	0.9	500/34.5	0.44	SEP
V-3/4	3/4	10.6	1.1	1.1	500/34.5	0.51	SEP
V-7/8	7/8	12.0	1.3	1.2	500/34.5	0.62	SEP
V-1-1/8	1-1/8	13.1	1.5	1.5	500/34.5	0.88	SEP
V-1-3/8	1-3/8	15.6	1.8	1.6	500/34.5	1.39	Cat I
V-1-5/8	1-5/8	16.9	2.2	2.0	500/34.5	1.98	Cat I
V-2-1/8	2-1/8	20.6	2.7	2.4	390/26.9	2.76	Cat I
V-2-5/8	2-5/8	24.3	3.4	3.0	339/23.4	5.29	Cat I
V-3-1/8	3-1/8	26.9	4.2	3.3	300/20.7	8.71	Cat I
V-3-5/8	3-5/8	32.2	5.2	3.9	175/12.0	13.23	Cat I
V-4-1/8	4-1/8	33.0	5.2	4.3	175/12.0	14.77	Cat I

Installation - Notes

1. The Vibration Eliminator should be fitted as close to the compressor as possible and must be installed in a straight line. Vibration Eliminators are not designed to compensate for pipework misalignment.
2. Care should be taken to allow sufficient space for the Vibration Eliminator to avoid static compression or tension, after brazing in place. Vibration Eliminators are not designed to absorb axial or torsional stress.
3. Vibration Eliminators should be installed perpendicular to the direction of vibration. When vibration exists in two planes, two Vibration Eliminators should be used. Refer to Fig 1 and 2.
4. For optimum absorption of vibration, the refrigerant line should be anchored at the end of the Vibration Eliminator furthest from the vibration source.
5. Take special care to install Vibration Eliminators horizontally when used in suction lines or where operating temperatures are below freezing point. Condensation may form on the outside of the unit and if installed vertically this may accumulate in the lower braid collar. In subsequent freezing this may deform and destroy the unit. If vertical installation is the only option, or indeed if condensation is possible with horizontal mounting, the entire flexible section, ferrules and braided hose, must be covered with a watertight synthetic material e.g. a heat shrinkable PVC sleeve.

6. The ferrule and start of braid must be wet-ragged for brazing, to prevent overheating and subsequent damage. All excess flux must be removed to prevent corrosion and premature failure.

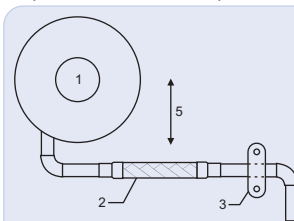

FIG 1 - SINGLE SYSTEM

- 1 Compressor
- 2 Vibration Eliminator
- 3 Secure to solid member
- 4 Horizontal motion
- 5 Vertical motion

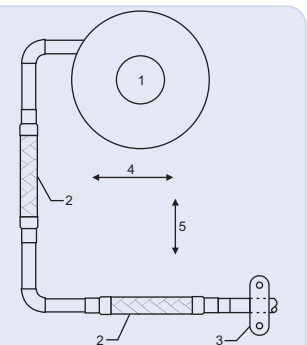

FIG 2 - DOUBLE SYSTEM

NOTES

SEALED FILTER DRIERS

Liquid Line Filter Driers

The function of a Liquid Line Filter Drier is to capture and retain system contaminants and moisture in order to protect system components and prevent harmful acids formation.

Applications

Henry Technologies' Liquid Line Filter Driers offer a high level of protection for refrigeration and air-conditioning systems. They are specifically designed to capture and retain moisture and solid particles from circulating throughout the system, which can create acid that causes damage to the compressor and other components piped within the circuit. Liquid line filter driers are suitable for HCFC, HFC and CO₂ refrigerants including R-410A, and their associated oils.

Main Features

- Solid copper ODS connections
- Plated Steel SAE flare connections
- Solid core construction of 100% Molecular Sieve desiccant
- Increased drying capacity over 80% Molecular Sieve and 20% Activated Alumina and cores
- Solid particle filtration down to 150 microns
- Powder coat finish suitable for UV rays and harsh environments
- 1000 hour salt spray tested to ASTM B117

Materials of Construction

The shell is constructed from carbon steel and powder coated for corrosion resistance. ODS connections are made from solid copper and SAE flare connections are made from plated steel. The spring is made from steel. The perforated plate is made from galvanized steel. The core is made from 100% molecular sieve. The filter pad is made from non-woven polyester. The filter mesh is made from stainless steel.

Technical Specifications

Maximum working pressure = 650 PSI (45 Bar)

Allowable operating temperature = -40°F to +212°F (-40°C to +100°C)

Liquid Line Filter Driers are UL and C-UL Listed by Underwriters Laboratories, Inc. Additionally, Liquid Line Filter Driers are CE marked in accordance with PED.



Selection Guidelines

Sealed Filter Driers should be selected for a particular application based on a number of factors. Full dimensional specifications are provided to ensure easy installation. Models should be selected based both on drying capacity and liquid capacity to ensure adequate drying and minimal pressure drop.

Installation - Notes

1. A moisture indicator should be installed in conjunction with each filter drier in order to monitor drying effectiveness.
2. Ensure the indicated flow direction is complied with.
3. Full instructions are given in the Product Instruction Sheet, included with each filter drier.

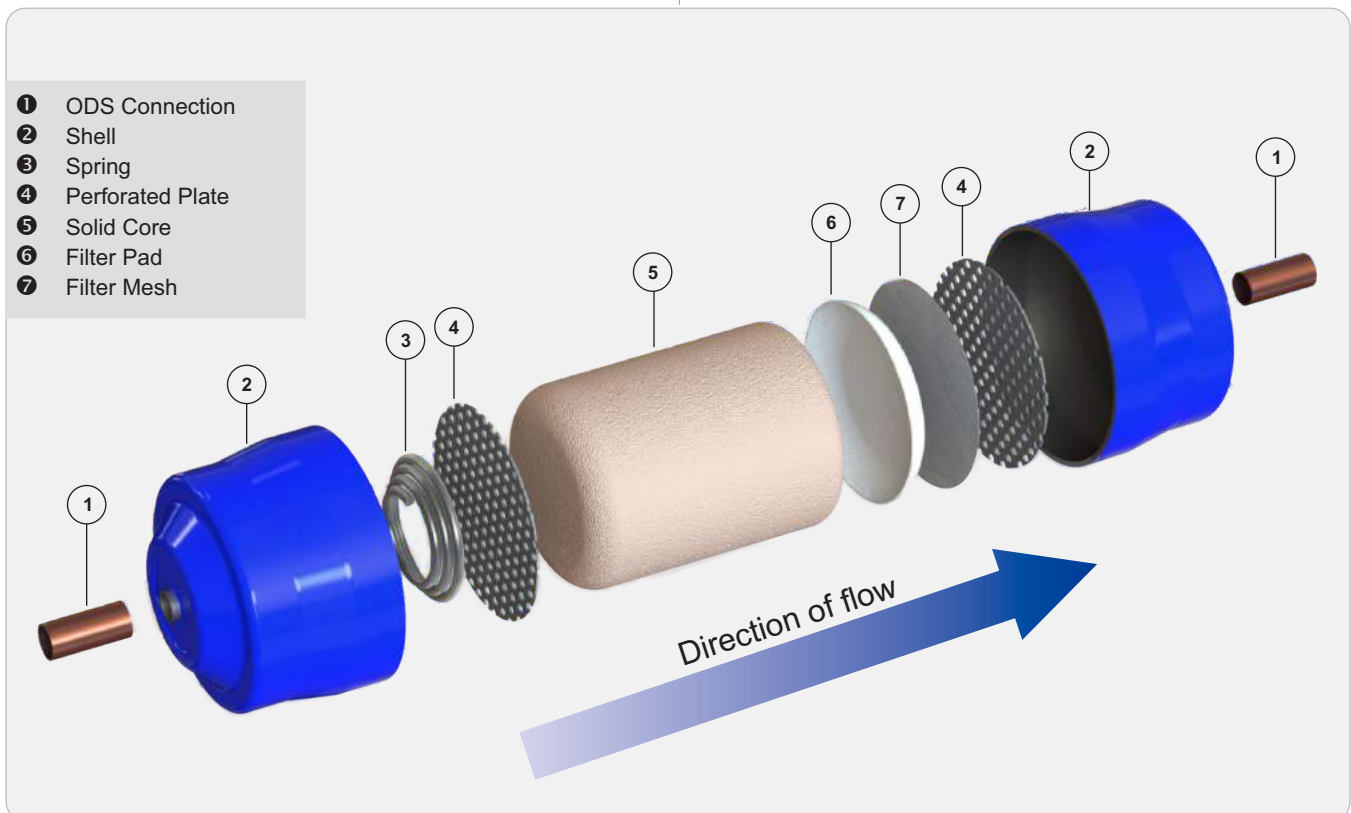

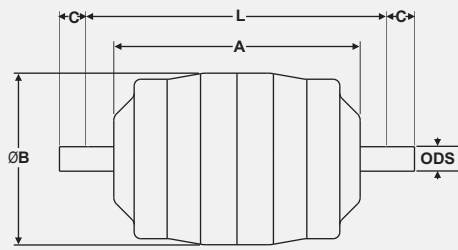

FIG 1

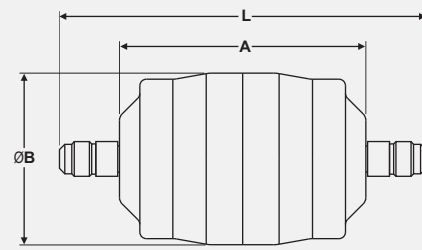

FIG 2

Part No	Fig No	ODS (inch)	Dimensions (inch)				CE Cat	Weight (lbs)
			L	A	ØB	C		
SDM-032S	1	1/4	3.19	2.48	1.81	0.51	SEP	0.51
SDM-033S	1	3/8	3.35	2.48	1.81	0.51	SEP	0.57
SDM-052S	1	1/4	3.54	2.83	2.56	0.51	SEP	0.79
SDM-053S	1	3/8	3.70	2.83	2.56	0.51	SEP	0.84
SDM-082S	1	1/4	4.57	3.86	2.56	0.51	SEP	1.06
SDM-083S	1	3/8	4.72	3.86	2.56	0.51	SEP	1.08
SDM-084S	1	1/2	4.80	3.86	2.56	0.51	SEP	1.10
SDM-162S	1	1/4	5.12	4.41	3.07	0.51	SEP	1.68
SDM-163S	1	3/8	5.28	4.41	3.07	0.51	SEP	1.79
SDM-164S	1	1/2	5.35	4.41	3.07	0.51	SEP	1.81
SDM-165S	1	5/8	5.28	4.41	3.07	0.51	SEP	1.98
SDM-303S	1	3/8	8.15	7.28	3.07	0.51	SEP	2.67
SDM-304S	1	1/2	8.23	7.28	3.07	0.51	SEP	2.76
SDM-305S	1	5/8	8.66	7.28	3.07	0.51	SEP	2.80
SDM-306S	1	3/4	8.23	7.28	3.07	0.59	SEP	2.84
SDM-307S	1	7/8	8.46	7.28	3.07	0.59	SEP	2.85
SDM-413S	1	3/8	8.43	7.56	3.62	0.51	CAT I	3.99
SDM-414S	1	1/2	8.50	7.56	3.62	0.51	CAT I	4.01
SDM-415S	1	5/8	8.43	7.56	3.62	0.51	CAT I	4.03
SDM-416S	1	3/4	8.50	7.56	3.62	0.59	CAT I	4.06

Part No	Fig No	SAE Flare (inch)	Dimensions (inch)			CE Cat	Weight (lbs)
			L	A	ØB		
SDM-032	2	1/4	4.33	2.48	1.81	SEP	0.57
SDM-033	2	3/8	4.72	2.48	1.81	SEP	0.68
SDM-052	2	1/4	4.69	2.83	2.56	SEP	0.88
SDM-053	2	3/8	5.08	2.83	2.56	SEP	0.97
SDM-082	2	1/4	5.71	3.86	2.56	SEP	1.15
SDM-083	2	3/8	6.10	3.86	2.56	SEP	1.21
SDM-084	2	1/2	6.42	3.86	2.56	SEP	1.28
SDM-162	2	1/4	6.26	4.41	3.07	SEP	1.65
SDM-163	2	3/8	6.65	4.41	3.07	SEP	1.74
SDM-164	2	1/2	6.97	4.41	3.07	SEP	1.83
SDM-165	2	5/8	7.28	4.41	3.07	SEP	1.98
SDM-303	2	3/8	9.53	7.28	3.07	SEP	2.73
SDM-304	2	1/2	9.84	7.28	3.07	SEP	2.84
SDM-305	2	5/8	10.16	7.28	3.07	SEP	2.98
SDM-306	2	3/4	10.39	7.28	3.07	SEP	3.02
SDM-413	2	3/8	9.80	7.56	3.62	CAT I	4.12
SDM-414	2	1/2	10.12	7.56	3.62	CAT I	4.17
SDM-415	2	5/8	10.43	7.56	3.62	CAT I	4.28
SDM-416	2	3/4	10.67	7.56	3.62	CAT I	4.34

DRYING CAPACITY RATINGS

Model Details Part No	Drying Capacity** (kg of refrigerant)							
	R22		R134a		R404A/R507		R407C/R410A	
	75°F (24°C)	125°F (52°C)	75°F (24°C)	125°F (52°C)	75°F (24°C)	125°F (52°C)	75°F (24°C)	125°F (52°C)
SDM-032S	4.9	4.6	5.3	5.0	7.8	4.8	5.3	4.6
SDM-033S	4.9	4.6	5.3	5.0	7.8	4.8	5.3	4.6
SDM-052S	9.8	9.1	10.6	10.1	15.6	9.6	10.6	9.1
SDM-053S	9.8	9.1	10.6	10.1	15.6	9.6	10.6	9.1
SDM-082S	15.8	14.6	16.9	16.1	24.9	15.4	17.0	14.6
SDM-083S	15.8	14.6	16.9	16.1	24.9	15.4	17.0	14.6
SDM-084S	15.8	14.6	16.9	16.1	24.9	15.4	17.0	14.6
SDM-162S	24.6	22.8	26.4	25.2	38.9	24.1	26.6	22.8
SDM-163S	24.6	22.8	26.4	25.2	38.9	24.1	26.6	22.8
SDM-164S	24.6	22.8	26.4	25.2	38.9	24.1	26.6	22.8
SDM-165S	24.6	22.8	26.4	25.2	38.9	24.1	26.6	22.8
SDM-303S	51.2	47.4	55.0	52.3	81.0	50.0	55.3	47.4
SDM-304S	51.2	47.4	55.0	52.3	81.0	50.0	55.3	47.4
SDM-305S	51.2	47.4	55.0	52.3	81.0	50.0	55.3	47.4
SDM-306S	51.2	47.4	55.0	52.3	81.0	55.0	55.3	47.4
SDM-307S*	51.2	47.4	55.0	52.3	81.0	55.0	55.3	47.4
SDM-413S	76.8	71.2	82.4	78.5	121.4	75.0	82.9	71.1
SDM-414S	76.8	71.2	82.4	78.5	121.4	75.0	82.9	71.1
SDM-415S	76.8	71.2	82.4	78.5	121.4	75.0	82.9	71.1
SDM-416S	76.8	71.2	82.4	78.5	121.4	75.0	82.9	71.1

Model Details Part No	Drying Capacity*** (drops of water)											
	R22		R134a		R507		R404A		R407C		R410A	
	75°F (24°C)	125°F (52°C)	75°F (24°C)	125°F (52°C)	75°F (24°C)	125°F (52°C)	75°F (24°C)	125°F (52°C)	75°F (24°C)	125°F (52°C)	75°F (24°C)	125°F (52°C)
SDM-032S	88.2	82.8	94.0	88.6	140.4	86.4	140.4	86.4	95.4	82.8	95.4	82.8
SDM-033S	88.2	82.8	94.0	88.6	140.4	86.4	140.4	86.4	95.4	82.8	95.4	82.8
SDM-052S	176.4	163.8	187.9	179.0	280.8	172.8	280.8	172.8	190.8	163.8	190.8	163.8
SDM-053S	176.4	163.8	187.9	179.0	280.8	172.8	280.8	172.8	190.8	163.8	190.8	163.8
SDM-082S	284.4	262.8	299.6	285.4	448.2	277.2	448.2	277.2	306.0	262.8	306.0	262.8
SDM-083S	284.4	262.8	299.6	285.4	448.2	277.2	448.2	277.2	306.0	262.8	306.0	262.8
SDM-084S	284.4	262.8	299.6	285.4	448.2	277.2	448.2	277.2	306.0	262.8	306.0	262.8
SDM-162S	442.8	410.4	468.0	446.7	700.2	433.8	700.2	433.8	478.8	410.4	478.8	410.4
SDM-163S	442.8	410.4	468.0	446.7	700.2	433.8	700.2	433.8	478.8	410.4	478.8	410.4
SDM-164S	442.8	410.4	468.0	446.7	700.2	433.8	700.2	433.8	478.8	410.4	478.8	410.4
SDM-165S	442.8	410.4	468.0	446.7	700.2	433.8	700.2	433.8	478.8	410.4	478.8	410.4
SDM-303S	921.6	853.2	975.0	927.1	1458.0	900.0	1458.0	900.0	995.4	853.2	995.4	853.2
SDM-304S	921.6	853.2	975.0	927.1	1458.0	900.0	1458.0	900.0	995.4	853.2	995.4	853.2
SDM-305S	921.6	853.2	975.0	927.1	1458.0	900.0	1458.0	900.0	995.4	853.2	995.4	853.2
SDM-306S	921.6	853.2	975.0	927.1	1458.0	900.0	1458.0	900.0	995.4	853.2	995.4	853.2
SDM-307S*	921.6	853.2	975.0	927.1	1458.0	900.0	1458.0	900.0	995.4	853.2	995.4	853.2
SDM-413S	1382.4	1281.6	1460.7	1391.6	2185.2	1350.0	2185.2	1350.0	1492.2	1279.8	1492.2	1279.8
SDM-414S	1382.4	1281.6	1460.7	1391.6	2185.2	1350.0	2185.2	1350.0	1492.2	1279.8	1492.2	1279.8
SDM-415S	1382.4	1281.6	1460.7	1391.6	2185.2	1350.0	2185.2	1350.0	1492.2	1279.8	1492.2	1279.8
SDM-416S	1382.4	1281.6	1460.7	1391.6	2185.2	1350.0	2185.2	1350.0	1492.2	1279.8	1492.2	1279.8

*Drying capacity is identical for ODS and SAE Flare models. Noted size is only available in ODS connections

**Drying Capacity is based on the following moisture content before and after drying:

R22: From 1050 ppm W to 60 ppm W in accordance with ARI 710-86

R134a: From 1050 ppm W to 75 ppm W. If refrigerant is to be dried to 50 ppm W, reduce the stated capacities by 15%

R404A, R407C, R507: From 1020 ppm W to 30 ppm W

R410A: From 1050 ppm W to 60 ppm W

***20 drops = 1 gram in accordance with ARI 710-86

LIQUID CAPACITY RATINGS

Model Details Part No	Liquid Capacity**											
	R22		R134a		R404A		R407C		R410A		CO ₂	
	Tons	kW	Tons	kW	Tons	kW	Tons	kW	Tons	kW	Tons	kW
SDM-032S	1.7	6.1	1.6	5.8	0.9	3.2	1.7	6.1	1.8	6.5	2.5	8.9
SDM-033S	5.9	20.8	5.0	17.7	2.9	10.3	5.9	20.8	6.3	22.1	7.7	27.1
SDM-052S	2.2	7.7	1.8	6.4	1.0	3.5	2.2	7.7	2.3	8.2	2.8	9.8
SDM-053S	5.4	19.0	4.9	17.2	2.9	10.2	5.4	19.0	5.7	20.2	7.5	26.3
SDM-082S	2.2	7.9	1.9	6.6	1.0	3.6	2.2	7.9	2.4	8.5	2.9	10.1
SDM-083S	6.2	21.7	5.3	18.7	3.0	10.5	6.2	21.7	6.6	23.1	8.2	28.7
SDM-084S	8.8	31.1	7.6	26.7	4.4	15.6	8.8	31.1	9.4	33.2	11.6	40.8
SDM-162S	2.4	8.6	2.0	7.2	1.1	3.9	2.4	8.6	2.6	9.2	3.1	11.0
SDM-163S	6.5	23.0	5.7	20.1	3.2	11.1	6.5	23.0	7.0	24.5	8.8	30.8
SDM-164S	9.9	34.9	8.6	30.3	4.8	16.9	9.9	34.9	10.6	37.3	13.2	46.4
SDM-165S	9.8	34.4	8.6	30.1	4.5	16.0	9.8	34.4	10.4	36.7	13.1	46.1
SDM-303S	6.6	23.2	5.7	20.2	3.1	11.0	6.6	23.2	6.9	24.1	8.8	31.0
SDM-304S	10.1	35.7	8.8	31.1	4.8	16.8	10.1	35.7	10.8	38.1	13.5	47.6
SDM-305S	12.4	43.5	10.9	38.2	6.1	21.3	12.4	43.5	13.2	46.4	16.6	58.4
SDM-306S	18.3	64.3	15.9	56.0	8.8	30.9	18.3	64.3	19.5	68.5	24.3	85.6
SDM-307S*	19.9	70.1	17.4	61.2	9.6	33.8	19.9	70.1	21.3	74.8	26.6	93.6
SDM-413S	7.5	26.3	6.6	23.2	3.6	12.7	7.5	26.3	8.0	28.0	10.1	35.5
SDM-414S	11.8	41.6	10.3	36.4	5.7	19.9	11.8	41.6	12.6	44.4	15.8	55.6
SDM-415S	16.6	58.3	14.5	50.9	7.7	27.1	16.6	58.3	17.7	62.2	22.1	77.9
SDM-416S	19.2	67.7	16.8	59.1	8.9	31.4	19.2	67.7	20.5	72.2	25.7	90.4

*Liquid capacity is identical for ODS and SAE Flare models. Noted size is only available in ODS connections

**Liquid capacity is based on the following conditions:

Evaporating temperature of $t_e = +5^\circ\text{F} (-15^\circ\text{C})$ ($-22^\circ\text{F} (-30^\circ\text{C})$ for CO₂)

Condensing temperature of $t_c = +86^\circ\text{F} (+30^\circ\text{C})$ ($+23^\circ\text{F} (-5^\circ\text{C})$ for CO₂)

Pressure drop across filter drier of $\Delta p = 1 \text{ PSI} (0.07 \text{ bar})$

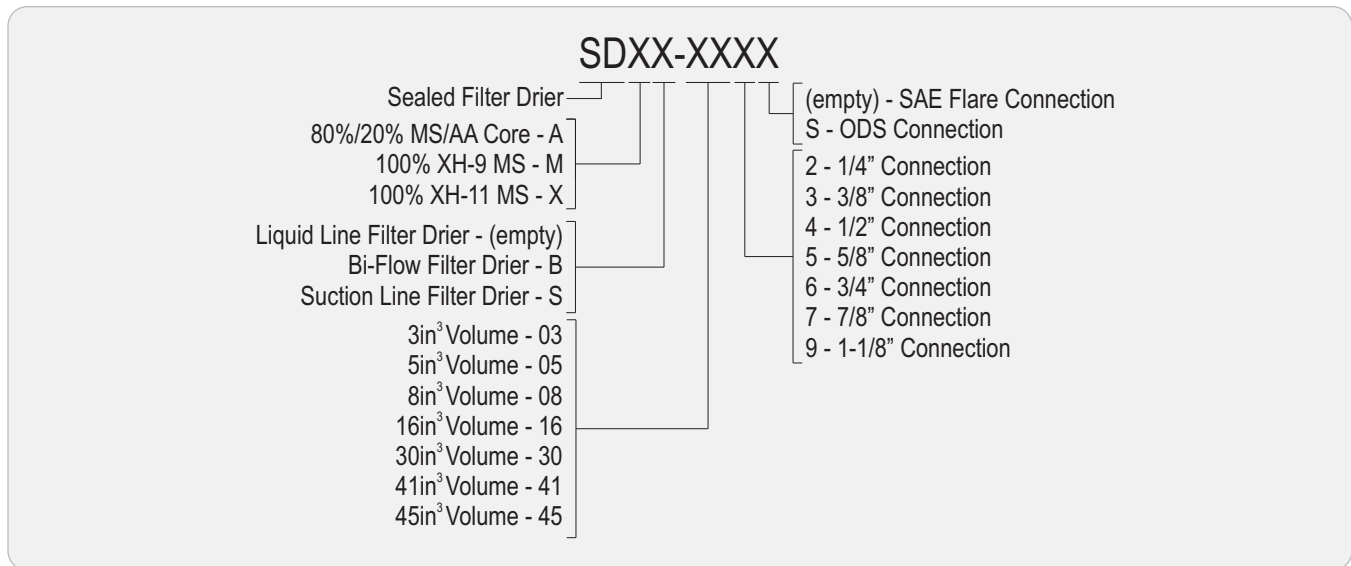

SEALED FILTER DRIERS

Bi-Flow Filter Driers

The function of a Bi-Flow Filter Drier is to capture and retain system contaminants and moisture in order to protect system components and prevent harmful acids formation in refrigerant systems requiring bi-directional flow.

Applications

Henry Technologies' Bi-Flow Filter Driers offer a high level of protection for refrigeration and air-conditioning systems. They are specifically designed to capture and retain moisture and solid particles from circulating throughout the system, which can create acid that causes damage to the compressor and other components piped within the circuit. Bi-flow filter driers are suitable for HCFC, HFC and CO₂ refrigerants including R-410A, and their associated oils.

Main Features

- Solid copper ODS connections
- Solid core construction of 100% Molecular Sieve desiccant
- Increased drying capacity over 80% Molecular Sieve and 20% Activated Alumina and cores
- Solid particle filtration down to 150 microns
- Powder coat finish suitable for UV rays and harsh environments
- 1000 hour salt spray tested to ASTM B117

Materials of Construction

The shell is constructed from carbon steel and powder coated for corrosion resistance. The connection is ODS and made from solid copper. The valve plate assembly and perforated plate are made from galvanized steel. The core is made from 100% molecular sieve. The filter pad is made from non-woven polyester. The filter mesh is made from stainless steel.

Technical Specifications

Maximum working pressure = 650 PSI (45 Bar)

Allowable operating temperature = -40°F to +212°F (-40°C to +100°C)

Bi-Flow Filter Driers are UL and C-UL Listed by Underwriters Laboratories, Inc. Additionally, Bi-Flow Filter Driers are CE marked in accordance with PED.



Selection Guidelines

Sealed Filter Driers should be selected for a particular application based on a number of factors. Full dimensional specifications are provided to ensure easy installation. Models should be selected based both on drying capacity and liquid capacity to ensure adequate drying and minimal pressure drop.

Installation - Notes

1. A moisture indicator should be installed in conjunction with each filter drier in order to monitor drying effectiveness.
2. Full instructions are given in the Product Instruction Sheet, included with each filter drier.

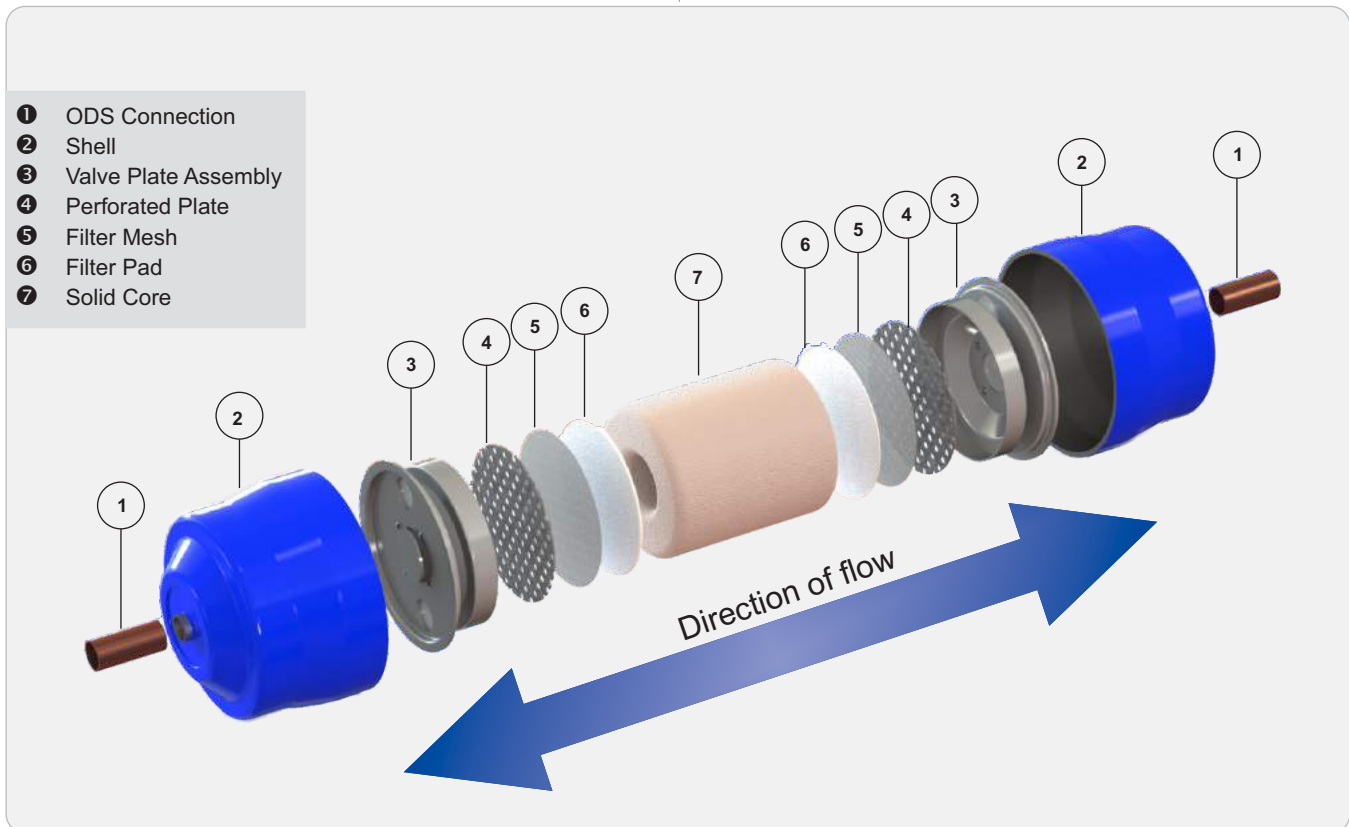

SDXX-XXXX

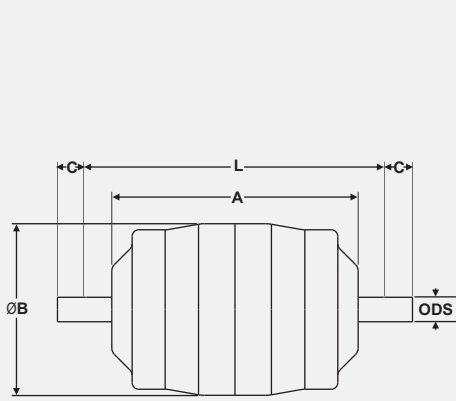

- Sealed Filter Drier
 - 80%/20% MS/AA Core - A
 - 100% XH-9 MS - M
 - 100% XH-11 MS - X
 - Liquid Line Filter Drier - (empty)
 - Bi-Flow Filter Drier - B
 - Suction Line Filter Drier - S
 - 3in³ Volume - 03
 - 5in³ Volume - 05
 - 8in³ Volume - 08
 - 16in³ Volume - 16
 - 30in³ Volume - 30
 - 41in³ Volume - 41
 - 45in³ Volume - 45
- (empty) - SAE Flare Connection
 S - ODS Connection
 2 - 1/4" Connection
 3 - 3/8" Connection
 4 - 1/2" Connection
 5 - 5/8" Connection
 6 - 3/4" Connection
 7 - 7/8" Connection
 9 - 1-1/8" Connection

Part No	ODS (inch)	Dimensions (inch)				CE Cat	Weight (lbs)
		L	A	ØB	C		
SDXB-083S	3/8	4.72	3.86	2.60	0.51	SEP	0.95
SDXB-163S	3/8	5.28	4.41	3.07	0.51	SEP	1.40
SDXB-164S	1/2	5.35	4.41	3.07	0.51	SEP	1.40
SDXB-305S	5/8	8.66	7.28	3.07	0.51	SEP	2.85
SDXB-456S	3/4	9.06	8.03	3.62	0.59	CAT I	3.85

DRYING AND LIQUID CAPACITY RATINGS

Model Details	Drying Capacity* (kg of refrigerant)							
	R22		R134a		R404A/R507		R407C/R410A	
	75°F (24°C)	125°F (52°C)	75°F (24°C)	125°F (52°C)	75°F (24°C)	125°F (52°C)	75°F (24°C)	125°F (52°C)
SDXB-083S	8.9	8.2	9.5	9.1	14.0	8.7	9.6	8.2
SDXB-163S	14.8	13.7	15.9	15.1	23.4	14.4	15.9	13.7
SDXB-164S	14.8	13.7	5.9	15.1	23.4	14.4	15.9	13.7
SDXB-305S	30.5	28.3	32.8	31.2	48.3	29.8	33.0	28.3
SDXB-456S	58.1	53.8	62.4	59.4	91.9	56.8	62.7	53.8

Model Details	Drying Capacity** (drops of water)											
	R22		R134a		R507		R404A		R407C		R410A	
	75°F (24°C)	125°F (52°C)	75°F (24°C)	125°F (52°C)	75°F (24°C)	125°F (52°C)	75°F (24°C)	125°F (52°C)	75°F (24°C)	125°F (52°C)	75°F (24°C)	125°F (52°C)
SDXB-083S	159.5	147.8	168.6	160.6	252.2	155.8	252.2	155.8	172.3	147.6	172.3	147.6
SDXB-163S	265.8	246.3	281.1	267.6	420.4	259.7	420.4	259.7	287.1	246.1	287.1	246.1
SDXB-164S	265.8	246.3	281.1	267.6	420.4	259.7	420.4	259.7	287.1	246.1	287.1	246.1
SDXB-305S	549.4	509.0	580.8	553.0	868.8	536.8	868.8	536.8	593.3	508.6	593.3	508.6
SDXB-456S	1045.6	968.8	1105.5	1052.5	1653.5	1021.7	1653.5	1021.7	1129.2	967.9	1129.2	967.9

*Drying Capacity is based on the following moisture content before and after drying:

- R22:** From 1050 ppm W to 60 ppm W in accordance with ARI 710-86
- R134a:** From 1050 ppm W to 75 ppm W. If refrigerant is to be dried to 50 ppm W, reduce the stated capacities by 15%
- R404A, R407C, R507:** From 1020 ppm W to 30 ppm W
- R410A:** From 1050 ppm W to 60 ppm W

**20 drops = 1 gram in accordance with ARI 710-86

Model Details	Liquid Capacity*											
	R22		R134a		R404A		R407C		R410A		CO ₂	
	Tons	KW	Tons	KW	Tons	KW	Tons	KW	Tons	KW	Tons	KW
SDXB-083S	2.3	8.0	2.1	7.4	1.2	4.1	2.3	8.0	2.3	8.0	2.8	10.0
SDXB-163S	5.4	18.9	4.8	17.0	2.7	9.4	5.4	18.9	5.4	18.9	6.7	23.7
SDXB-164S	8.5	30.0	7.7	27.0	4.3	15.0	8.5	30.0	8.5	30.0	10.7	37.6
SDXB-305S	10.2	35.8	9.2	32.3	5.1	18.0	10.2	35.8	10.2	35.8	12.8	44.9
SDXB-456S	15.9	56.1	13.9	48.9	7.7	27.1	15.9	56.1	17.0	59.8	21.3	74.9

*Liquid capacity is based on the following conditions:
 Evaporating temperature of t_e = +5°F (-15°C) (-22°F (-30°C) for CO₂)
 Condensing temperature of t_c = +86°F (+30°C) (+23°F (-5°C) for CO₂)
 Pressure drop across filter drier of Δp = 1 PSI (0.07 bar)

SEALED FILTER DRIERS

Suction Line Filter Driers

The function of a Suction Line Filter Drier is to capture and retain system contaminants, moisture and harmful acids in order to protect system components.

Applications

Henry Technologies' Suction Line Filter Driers offer a high level of protection for refrigeration and air-conditioning systems. They are specifically designed to capture and retain moisture and solid particles from circulating throughout the system, which can create acid that causes damage to the compressor and other components piped within the circuit. Suction line filter driers are suitable for HCFC, HFC and CO₂ refrigerants including R-410A, and their associated oils. Suction line filter driers are not recommended for use with oils that contain additives.

Main Features

- Solid copper ODS connections
- Solid core construction of 80% Molecular Sieve and 20% Activated Alumina
- High moisture absorption with added acid absorption over 100% Molecular Sieve desiccant
- Stainless steel mesh and post core non-woven polyester filter provide increased filtration efficiency
- Double 1/4" SAE flare connections with Schrader valves for easy pressure drop monitoring
- Solid particle filtration down to 150 microns
- Powder coat finish suitable for UV rays and harsh environments
- 1000 hour salt spray tested to ASTM B117

Materials of Construction

The shell is constructed from carbon steel and powder coated for corrosion resistance. The connection is ODS and made from solid copper. The spring is made from steel. The schrader fitting is 1/4" SAE Fl. steel. The perforated plate are made from galvanized steel. The core is made from 80% Molecular Sieve and 20% Activated Alumina. The filter pad is made from non-woven polyester. The filter mesh is made from stainless steel.

Technical Specifications

Maximum working pressure = 650 PSI (45 Bar)

Allowable operating temperature = -40°F to +212°F (-40°C to +100°C)

Suction Line Filter driers are UL and C-UL Listed by Underwriters Laboratories, Inc. Additionally, Suction Line Filter driers are CE marked in accordance with PED.



Selection Guidelines

Sealed Filter Driers should be selected for a particular application based on a number of factors. Full dimensional specifications are provided to ensure easy installation. Models should be selected based both on drying capacity and Flow capacity to ensure adequate drying and minimal pressure drop.

Installation - Notes

1. A moisture indicator should be installed in conjunction with each filter drier in order to monitor drying effectiveness.
2. Ensure the indicated flow direction is complied with.
3. Full instructions are given in the Product Instruction Sheet, included with each filter drier.

- | | |
|--------------------|--------------------|
| ① ODS Connection | ⑥ Solid Core |
| ② Shell | ⑦ Filter Pad |
| ③ Schrader Fitting | ⑧ Filter Mesh |
| ④ Valve Core | ⑨ Perforated Plate |
| ⑤ Spring | |

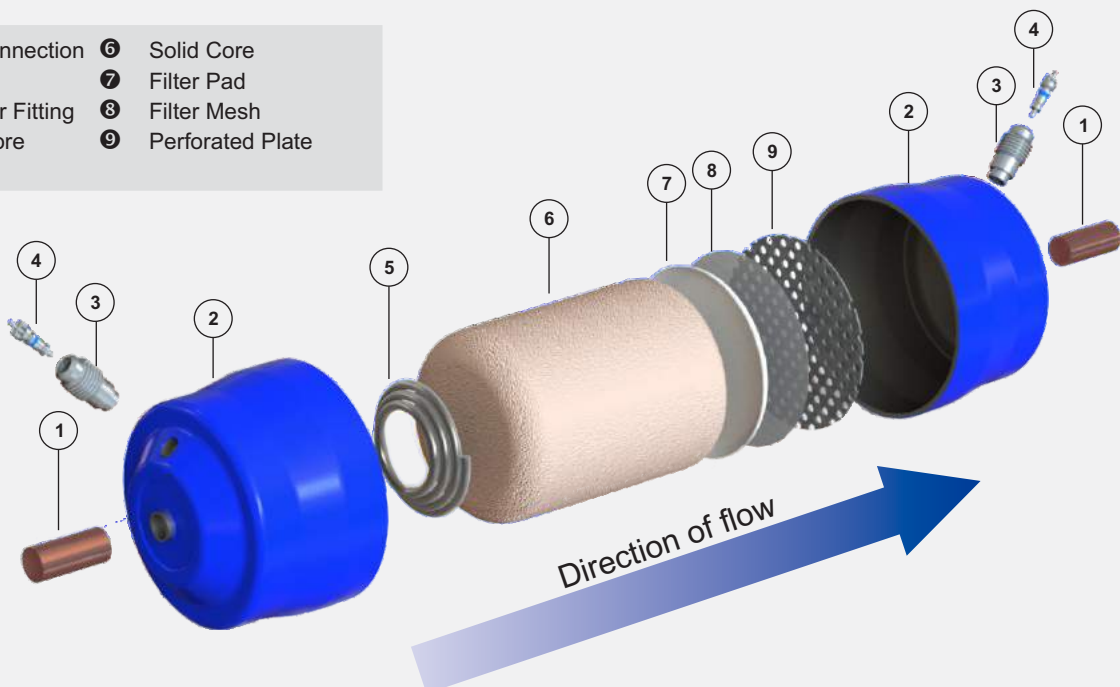

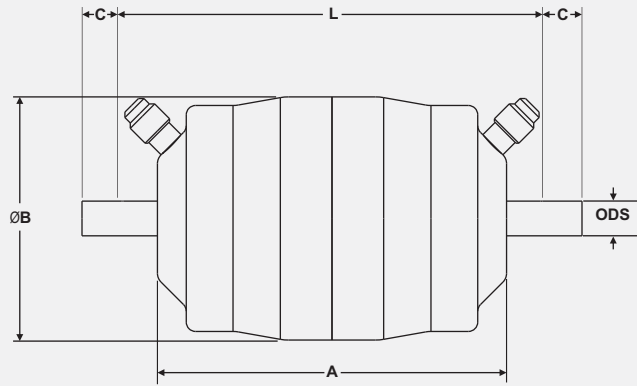

Part No	ODS (inch)	Dimensions (inch)				CE Cat	Weight (lbs)
		L	A	ØB	C		
SDAS-165S	5/8	5.28	4.41	3.07	0.51	SEP	1.50
SDAS-166S	3/4	5.35	4.41	3.07	0.59	SEP	1.55
SDAS-167S	7/8	5.59	4.41	3.07	0.59	SEP	1.60
SDAS-305S	5/8	8.66	7.28	3.07	0.51	SEP	2.75
SDAS-306S	3/4	8.23	7.28	3.07	0.59	SEP	2.80
SDAS-307S	7/8	8.46	7.28	3.07	0.59	SEP	2.85
SDAS-309S	1-1/8	8.46	7.28	3.07	0.59	SEP	2.90

DRYING CAPACITY RATINGS

Model Details Part No	Drying Capacity* (kg of refrigerant)							
	R22		R134a		R404A/R507		R407C/R410A	
	75°F (24°C)	125°F (52°C)	75°F (24°C)	125°F (52°C)	75°F (24°C)	125°F (52°C)	75°F (24°C)	125°F (52°C)
SDAS-165S	21.5	19.9	23.1	22.0	37.0	19.9	22.6	19.3
SDAS-166S	21.5	19.9	23.1	22.0	37.0	19.9	22.6	19.3
SDAS-167S	21.5	19.9	23.1	22.0	37.0	19.9	22.6	19.3
SDAS-305S	44.8	41.5	48.1	45.7	77.0	41.5	47.1	40.2
SDAS-306S	44.8	41.5	48.1	45.7	77.0	41.5	47.1	40.2
SDAS-307S	44.8	41.5	48.1	45.7	77.0	41.5	47.1	40.2
SDAS-309S	44.8	41.5	48.1	45.7	77.0	41.5	47.1	40.2

Model Details Part No	Drying Capacity** (drops of water)											
	R22		R134a		R507		R404A		R407C		R410A	
	75°F (24°C)	125°F (52°C)	75°F (24°C)	125°F (52°C)	75°F (24°C)	125°F (52°C)	75°F (24°C)	125°F (52°C)	75°F (24°C)	125°F (52°C)	75°F (24°C)	125°F (52°C)
SDAS-165S	387.0	358.2	409.5	390.0	415.8	396.0	666.0	358.2	406.8	347.4	406.8	347.4
SDAS-166S	387.0	358.2	409.5	390.0	415.8	396.0	666.0	358.2	406.8	347.4	406.8	347.4
SDAS-167S	387.0	358.2	409.5	390.0	415.8	396.0	666.0	358.2	406.8	347.4	406.8	347.4
SDAS-305S	806.4	747.0	852.7	810.1	865.8	822.6	1386.0	747.0	847.8	723.6	847.8	723.6
SDAS-306S	806.4	747.0	852.7	810.1	865.8	822.6	1386.0	747.0	847.8	723.6	847.8	723.6
SDAS-307S	806.4	747.0	852.7	810.1	865.8	822.6	1386.0	747.0	847.8	723.6	847.8	723.6
SDAS-309S	806.4	747.0	852.7	810.1	865.8	822.6	1386.0	747.0	847.8	723.6	847.8	723.6

*Drying Capacity is based on the following moisture content before and after drying:

R22: From 1050 ppm W to 60 ppm W in accordance with ARI 710-86

R134a: From 1050 ppm W to 75 ppm W. If refrigerant is to be dried to 50 ppm W, reduce the stated capacities by 15%

R404A, R407C, R507: From 1020 ppm W to 30 ppm W

R410A: From 1050 ppm W to 60 ppm W

**20 drops = 1 gram in accordance with ARI 710-86

LIQUID CAPACITY RATINGS

Model Details Part No	Liquid Capacity*												Acid Capacity** (g)
	R22		R134a		R404A		R407C		R410A		CO ₂		
	Tons	kW	Tons	kW	Tons	kW	Tons	kW	Tons	kW	Tons	kW	
SDAS-165S	12.0	42.2	10.5	36.8	5.8	20.4	12.0	42.2	12.8	45.0	16.0	56.3	4.0
SDAS-166S	15.0	52.6	13.0	45.9	7.2	25.4	15.0	52.6	15.9	56.1	20.0	70.2	4.0
SDAS-167S	17.7	62.2	15.4	54.3	8.5	30.0	17.7	62.2	18.9	66.3	23.6	83.0	4.0
SDAS-305S	12.4	43.5	10.9	38.2	6.1	21.3	12.4	43.5	13.2	46.4	16.6	58.4	8.3
SDAS-306S	18.3	64.3	15.9	56.0	8.8	30.9	18.3	64.3	19.5	68.5	24.3	85.6	8.3
SDAS-307S	18.3	64.3	15.9	56.0	8.8	30.9	18.3	64.3	19.5	68.5	24.3	85.6	8.3
SDAS-309S	25.1	88.3	21.9	77.1	12.1	42.6	25.1	88.3	26.8	94.2	33.5	117.9	8.3

*Liquid capacity is based on the following conditions:
 Evaporating temperature of $t_e = +5^\circ\text{F} (-15^\circ\text{C})$ ($-22^\circ\text{F} (-30^\circ\text{C})$ for CO₂)
 Condensing temperature of $t_c = +86^\circ\text{F} (+30^\circ\text{C})$ ($+23^\circ\text{F} (-5^\circ\text{C})$ for CO₂)
 Pressure drop across filter drier of $\Delta p = 1 \text{ PSI} (0.07 \text{ bar})$
 ** Acid capacity is based on absorption capacity of oleic acid at 0.05TAN (Total Acid Number)

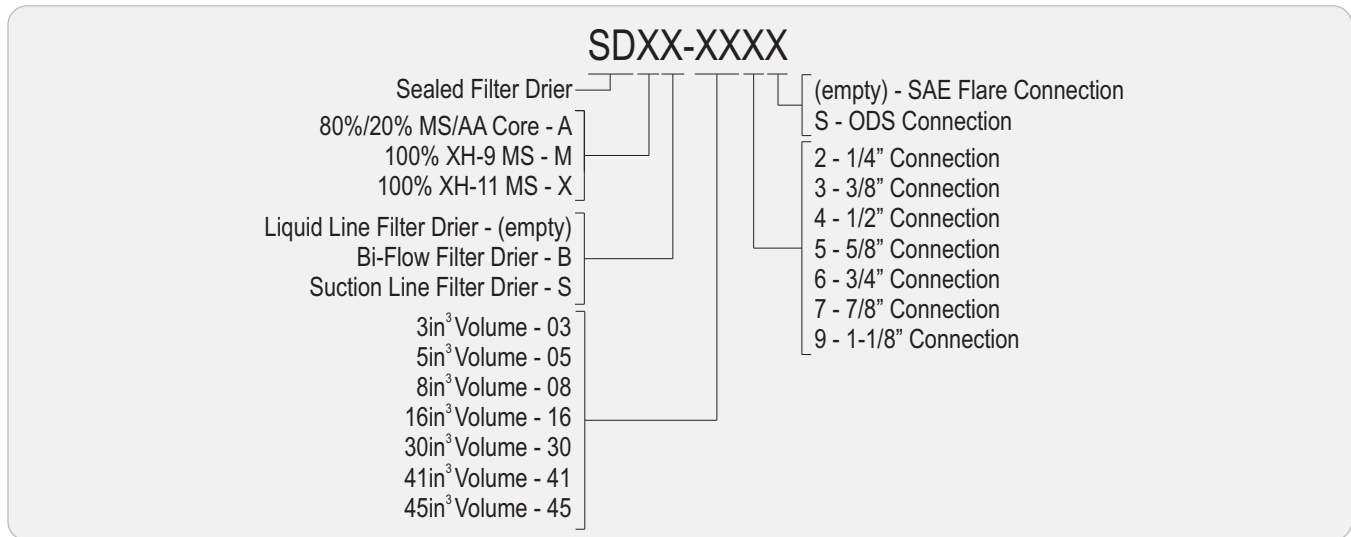

Replaceable Core Filter Driers

The function of a filter drier is to remove system contaminants, acid and moisture.

Applications

The Henry Technologies range of replaceable core filter driers are designed to be used in both the liquid and suction lines of refrigeration and air-conditioning systems. The product range is suitable for use with HCFC, HFC and CO₂ refrigerants (see core data).

Main Features

- Proven system protector
- High filtering capability
- High moisture absorption and acid removal
- Stainless steel mesh screen
- Solid copper full flow connections
- Interchangeable cores
- Corrosion-resistant, powder coated shells
- 1/4 NPT Pressure Tapping
- Nickel Plated Steel Cover Plate

Cores

S-848-CM

- 100% molecular sieve
- High drying capacity
- Suitable for HCFC, HFC and CO₂ refrigerants

S-848-C

- 80% molecular sieve and 20% activated alumina
- Absorbs moisture and acid in the system
- Suitable for HCFC, HFC and CO₂ refrigerants
- Not suitable for oils containing additives

S-848-CC

- 47/48/5% molecular sieve/activated alumina/activated carbon
- High acid absorption
- Suitable for use after compressor burnout
- Suitable for HCFC, HFC and CO₂ refrigerants
- Not suitable for oils containing additives

S-848-SC

- 100% molecular sieve
- Low pressure drop
- Suitable for HCFC, HFC and CO₂ refrigerants

S-848-F

- Filter element
- Low pressure drop
- Use when moisture removal is not required

Note: Cores not included with drier shells - to be ordered separately



Materials of Construction

Drier Shells

The main shell and fixed end caps are constructed from carbon steel and are powder coated for corrosion resistance. The cover plate is constructed from nickel plated steel. The ODS connections are copper.

Cores

Each core is constructed from a molded composite of desiccant material(s) bonded to provide very high mechanical strength, micron filtration, high moisture absorption and acid removal where applicable. Each core is fully activated and placed in a hermetically sealed container.

Technical Specifications

Maximum working pressure = 609 PSI (42 Bar)

Allowable operating temperature = -40°F to +158°F (-40°C to +70°C)

Selection Guidelines

The user should select a model based on refrigerant type, refrigeration capacity and the preferred degree of moisture/acid removal required. The preferred connection size can then be matched to the system requirements to establish which model is best. Alternatively, the user may select a connection size first and then check that the application is within the refrigeration capacity limits of the selected model.

Note: The user may decide to oversize the filter-drier based on experience or if the system contamination level is likely to be higher than normal.

Installation - Notes

1. Install the filter drier upstream of the liquid line controls to give the maximum protection. Locate upstream of moisture indicator so that drying effectiveness can be measured.
2. Ensure dimension 'F' is complied with in order to remove cores.
3. It is recommended to install the unit horizontally for easier core replacement.

Replaceable Core Filter Drier Shells

Model Details			Core Data		Dimensions (inch)						CE Cat	Weight (lbs)
Part No	ODS (inch)	Cores	Surface Area (inch ²)	Volume (inch ³)	A	B	C	D	E	F*		
SRC-485	5/8	1	105.9	43.7	6.8	4.5	2.3	10.8	4.5	6.8	CAT I	10.54
SRC-487	7/8	1	105.9	43.7	6.8	4.5	2.3	10.8	4.5	6.8	CAT I	10.60
SRC-967	7/8	2	211.7	87.4	12.3	4.5	2.3	16.3	4.5	12.3	CAT I	13.56
SRC-1447	7/8	3	317.6	131.1	18.0	4.5	2.3	22.0	4.5	18.0	CAT II	16.58
SRC-1927	7/8	4	423.5	174.8	23.6	4.5	2.3	27.6	4.5	23.6	CAT II	19.89
SRC-489	1 1/8	1	105.9	43.7	6.8	4.5	2.3	10.8	4.5	6.8	CAT I	10.65
SRC-969	1 1/8	2	211.7	87.4	12.3	4.5	2.3	16.3	4.5	12.3	CAT I	13.74
SRC-1449	1 1/8	3	317.6	131.1	18.0	4.5	2.3	22.0	4.5	18.0	CAT II	16.84
SRC-1929	1 1/8	4	423.5	174.8	23.6	4.5	2.3	27.6	4.5	23.6	CAT II	20.06
SRC-4811	1 3/8	1	105.9	43.7	6.8	4.5	2.3	10.8	4.5	6.8	CAT I	10.87
SRC-9611	1 3/8	2	211.7	87.4	12.3	4.5	2.3	16.3	4.5	12.3	CAT I	13.89
SRC-14411	1 3/8	3	317.6	131.1	18.0	4.5	2.3	22.0	4.5	18.0	CAT II	16.93
SRC-19211	1 3/8	4	423.5	174.8	23.6	4.5	2.3	27.6	4.5	23.6	CAT II	20.11
SRC-4813	1 5/8	1	105.9	43.7	6.8	4.5	2.3	10.8	4.5	6.8	CAT I	11.00
SRC-9613	1 5/8	2	211.7	87.4	12.3	4.5	2.3	16.3	4.5	12.3	CAT I	13.93
SRC-14413	1 5/8	3	317.6	131.1	18.0	4.5	2.3	22.0	4.5	18.0	CAT II	17.66
SRC-19213	1 5/8	4	423.5	174.8	23.6	4.5	2.3	27.6	4.5	23.6	CAT II	20.19
SRC-4817	2 1/8	1	105.9	43.7	6.8	4.5	2.3	10.8	4.5	6.8	CAT I	11.09
SRC-9617	2 1/8	2	211.7	87.4	12.3	4.5	2.3	16.3	4.5	12.3	CAT I	14.26
SRC-14417	2 1/8	3	317.6	131.1	18.0	4.5	2.3	22.0	4.5	18.0	CAT II	17.26
SRC-19217	2 1/8	4	423.5	174.8	23.6	4.5	2.3	27.6	4.5	23.6	CAT II	20.42
SRC-4821	2 5/8	1	105.9	43.7	6.8	4.5	2.3	10.8	4.5	6.8	CAT I	11.77
SRC-9621	2 5/8	2	211.7	87.4	12.3	4.5	2.3	16.3	4.5	12.3	CAT I	14.79
SRC-14421	2 5/8	3	317.6	131.1	18.0	4.5	2.3	22.0	4.5	18.0	CAT II	17.68
SRC-19221	2 5/8	4	423.5	174.8	23.6	4.5	2.3	27.6	4.5	23.6	CAT II	21.12

* 'F' is the minimum space required to remove the filter drier cores from the shell.

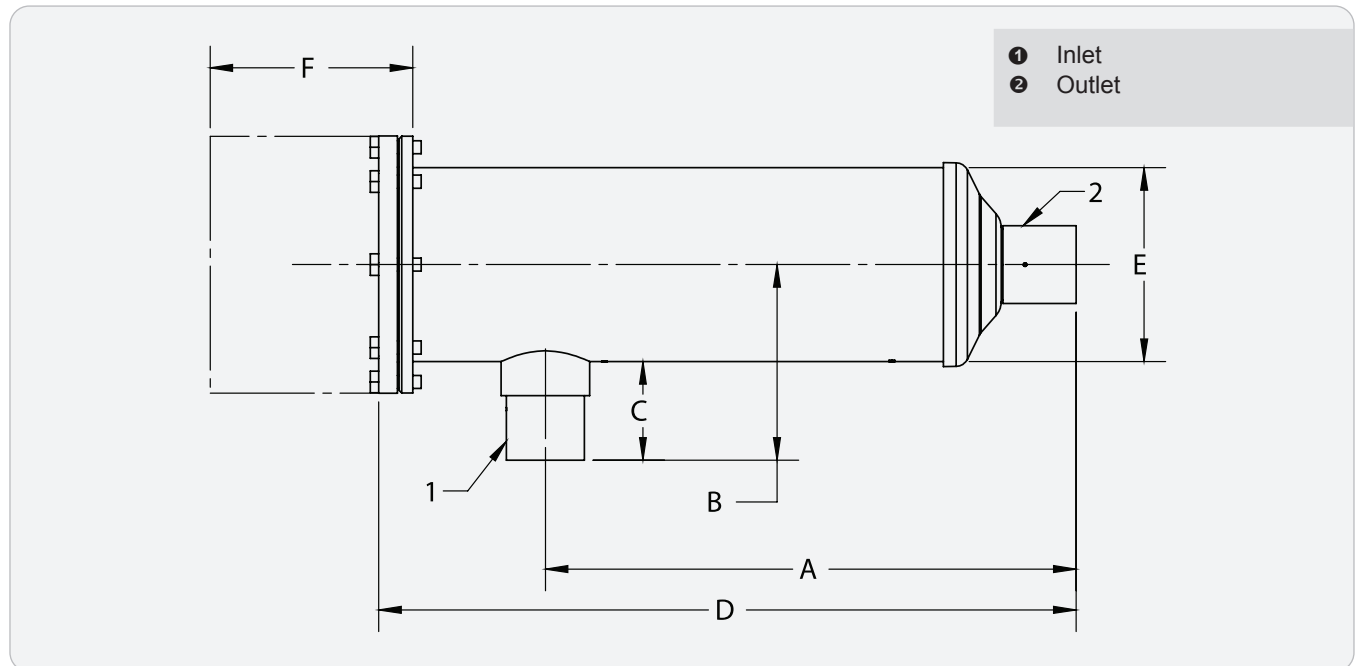

S-848-CM Core

Model Details			Drying Capacity (lbs of refrigerant)						Liquid Capacity (tons)					
Part No	ODS (inch)	Cores	R134a		R404A/R507		R407C/R410A		R134a	R404A	R507	R407C	R410A	CO ₂
			75°F	126°F	75°F	126°F	75°F	126°F						
SRC-485	5/8	1	184.1	175.3	271.2	167.6	185.2	158.7	22.2	16.4	15.9	23.3	24.3	35.8
SRC-487	7/8	1	184.1	175.3	271.2	167.6	185.2	158.7	35.3	25.5	24.7	36.6	37.7	56.0
SRC-967	7/8	2	368.2	350.5	542.3	335.1	370.4	317.5	33.0	23.6	22.9	34.0	34.9	52.4
SRC-1447	7/8	3	552.3	525.8	813.5	502.7	555.6	476.2	33.0	23.6	22.9	34.0	34.9	52.4
SRC-1927	7/8	4	736.3	701.1	1084.7	670.2	740.8	634.9	33.0	23.6	22.9	34.0	34.9	52.4
SRC-489	1-1/8	1	184.1	175.3	271.2	167.6	185.2	158.7	50.8	36.6	35.4	52.5	54.0	80.7
SRC-969	1-1/8	2	368.2	350.5	542.3	335.1	370.4	317.5	50.6	36.5	35.3	52.3	53.8	80.4
SRC-1449	1-1/8	3	552.3	525.8	813.5	502.7	555.6	476.2	49.3	35.5	34.4	50.9	52.4	78.2
SRC-1929	1-1/8	4	736.3	701.1	1084.7	670.2	740.8	634.9	49.3	35.5	34.4	50.9	52.4	78.2
SRC-4811	1-3/8	1	184.1	175.3	271.2	167.6	185.2	158.7	67.3	48.8	47.2	69.8	72.1	106.9
SRC-9611	1-3/8	2	368.2	350.5	542.3	335.1	370.4	317.5	68.7	49.5	48.0	71.0	73.2	109.0
SRC-14411	1-3/8	3	552.3	525.8	813.5	502.7	555.6	476.2	72.1	52.1	50.4	74.6	76.9	114.4
SRC-19211	1-3/8	4	736.3	701.1	1084.7	670.2	740.8	634.9	75.0	54.8	53.1	78.2	81.0	119.1
SRC-4813	1-5/8	1	184.1	175.3	271.2	167.6	185.2	158.7	77.8	56.8	55.1	81.2	84.1	123.5
SRC-9613	1-5/8	2	368.2	350.5	542.3	335.1	370.4	317.5	84.9	61.6	59.7	88.2	91.1	134.8
SRC-14413	1-5/8	3	552.3	525.8	813.5	502.7	555.6	476.2	85.1	61.8	59.8	88.4	91.3	135.1
SRC-19213	1-5/8	4	736.3	701.1	1084.7	670.2	740.8	634.9	88.0	64.0	62.0	91.5	94.6	139.6
SRC-4817	2-1/8	1	184.1	175.3	271.2	167.6	185.2	158.7	113.6	84.8	82.2	120.2	125.7	180.3
SRC-9617	2-1/8	2	368.2	350.5	542.3	335.1	370.4	317.5	119.4	87.4	84.7	124.7	129.3	189.5
SRC-14417	2-1/8	3	552.3	525.8	813.5	502.7	555.6	476.2	104.4	76.2	73.9	108.9	112.8	165.7
SRC-19217	2-1/8	4	736.3	701.1	1084.7	670.2	740.8	634.9	122.2	88.5	85.7	126.7	130.8	193.9
SRC-4821	2-5/8	1	184.1	175.3	271.2	167.6	185.2	158.7	83.9	61.3	59.5	87.5	90.7	130.9
SRC-9621	2-5/8	2	368.2	350.5	542.3	335.1	370.4	317.5	90.0	67.7	65.6	97.0	100.0	147.2
SRC-14421	2-5/8	3	552.3	525.8	813.5	502.7	555.6	476.2	80.3	63.0	61.1	90.1	93.2	137.1
SRC-19221	2-5/8	4	736.3	701.1	1084.7	670.2	740.8	634.9	95.9	77.8	75.3	111.3	114.9	170.3

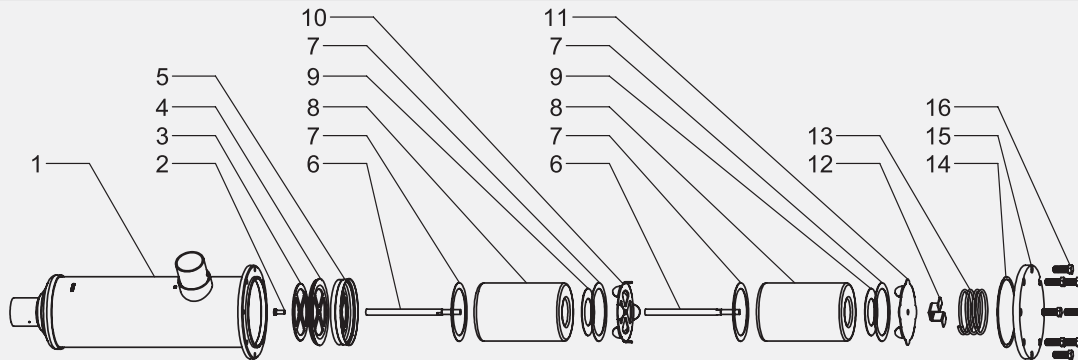

- ① Filter Drier Shell
- ② Retaining Bolt
- ③ End Plate
- ④ Mesh Screen & Rubber Seal
- ⑤ Core Holder
- ⑥ Central Rod
- ⑦ Large Gasket
- ⑧ Drier Core
- ⑨ Small Gasket
- ⑩ Core Plate
- ⑪ Cover End Plate
- ⑫ Wing Nut
- ⑬ Spring
- ⑭ Cover Gasket
- ⑮ Cover Plate
- ⑯ Cover Plate Bolts

S-848-C

Model Details			Drying Capacity (lbs of refrigerant)								Liquid Capacity (tons)					
Part No	ODS (inch)	Cores	R22		R134a		R404A/R507		R407C/R410A		R134a	R404A	R507	R22/ R407C	R410A	CO ₂
			75°F	126°F	75°F	126°F	75°F	126°F	75°F	126°F						
SRC-485	5/8	1	149.9	138.9	160.9	153.2	257.9	138.9	157.6	134.5	22.2	16.4	15.9	23.3	24.3	35.8
SRC-487	7/8	1	149.9	138.9	160.9	153.2	257.9	138.9	157.6	134.5	35.3	25.5	24.7	36.6	37.7	56.0
SRC-967	7/8	2	299.8	277.8	321.9	306.4	515.9	277.8	315.3	269.0	33.0	23.6	22.9	34.0	34.9	52.4
SRC-1447	7/8	3	449.7	416.7	482.8	459.7	773.8	416.7	472.9	403.5	33.0	23.6	22.9	34.0	34.9	52.4
SRC-1927	7/8	4	599.7	555.6	643.8	612.9	1031.8	555.6	630.5	537.9	33.0	23.6	22.9	34.0	34.9	52.4
SRC-489	1-1/8	1	149.9	138.9	160.9	153.2	257.9	138.9	157.6	134.5	50.8	36.6	35.4	52.5	54.0	80.7
SRC-969	1-1/8	2	299.8	277.8	321.9	306.4	515.9	277.8	315.3	269.0	50.6	36.5	35.3	52.3	53.8	80.4
SRC-1449	1-1/8	3	449.7	416.7	482.8	459.7	773.8	416.7	472.9	403.5	49.3	35.5	34.4	50.9	52.4	78.2
SRC-1929	1-1/8	4	599.7	555.6	643.8	612.9	1031.8	555.6	630.5	537.9	49.3	35.5	34.4	50.9	52.4	78.2
SRC-4811	1-3/8	1	149.9	138.9	160.9	153.2	257.9	138.9	157.6	134.5	67.3	48.8	47.2	69.8	72.1	106.9
SRC-9611	1-3/8	2	299.8	277.8	321.9	306.4	515.9	277.8	315.3	269.0	68.7	49.5	48.0	71.0	73.2	109.0
SRC-14411	1-3/8	3	449.7	416.7	482.8	459.7	773.8	416.7	472.9	403.5	72.1	52.1	50.4	74.6	76.9	114.4
SRC-19211	1-3/8	4	599.7	555.6	643.8	612.9	1031.8	555.6	630.5	537.9	75.0	54.8	53.1	78.2	81.0	119.1
SRC-4813	1-5/8	1	149.9	138.9	160.9	153.2	257.9	138.9	157.6	134.5	77.8	56.8	55.1	81.2	84.1	123.5
SRC-9613	1-5/8	2	299.8	277.8	321.9	306.4	515.9	277.8	315.3	269.0	84.9	61.6	59.7	88.2	91.1	134.8
SRC-14413	1-5/8	3	449.7	416.7	482.8	459.7	773.8	416.7	472.9	403.5	85.1	61.8	59.8	88.4	91.3	135.1
SRC-19213	1-5/8	4	599.7	555.6	643.8	612.9	1031.8	555.6	630.5	537.9	88.0	64.0	62.0	91.5	94.6	139.6
SRC-4817	2-1/8	1	149.9	138.9	160.9	153.2	257.9	138.9	157.6	134.5	113.6	84.8	82.2	120.2	125.7	180.3
SRC-9617	2-1/8	2	299.8	277.8	321.9	306.4	515.9	277.8	315.3	269.0	119.4	87.4	84.7	124.7	129.3	189.5
SRC-14417	2-1/8	3	449.7	416.7	482.8	459.7	773.8	416.7	472.9	403.5	104.4	76.2	73.9	108.9	112.8	165.7
SRC-19217	2-1/8	4	599.7	555.6	643.8	612.9	1031.8	555.6	630.5	537.9	122.2	88.5	85.7	126.7	130.8	193.9
SRC-4821	2-5/8	1	149.9	138.9	160.9	153.2	257.9	138.9	157.6	134.5	83.9	61.3	59.5	87.5	90.7	130.9
SRC-9621	2-5/8	2	299.8	277.8	321.9	306.4	515.9	277.8	315.3	269.0	90.0	67.7	65.6	97.0	100.0	147.2
SRC-14421	2-5/8	3	449.7	416.7	482.8	459.7	773.8	416.7	472.9	403.5	80.3	63.0	61.1	90.1	93.2	137.1
SRC-19221	2-5/8	4	599.7	555.6	643.8	612.9	1031.8	555.6	630.5	537.9	95.9	77.8	75.3	111.3	114.9	170.3

Drying capacity is based on the following moisture contents before and after drying:

- R22: From 1050 ppm W to 60 ppm W according to ARI 710-86
- R134a: From 1050 ppm W to 75 ppm W
- R404A, R407C, R507: From 1020 ppm W to 30 ppm W
- R410A: From 1050 ppm W to 60 ppm W

Liquid Capacity is based on:

- Evaporating temperature of $t_e = +5^\circ\text{F}$ (-22°F for CO₂)
- Condensing temperature of $t_c = +86^\circ\text{F}$ (23°F for CO₂)
- Pressure drop across filter drier of $p = 1.015$ PSI

S-848-CC

Cores	Drying Capacity (lbs of refrigerant)											
	Evaporating Temperature t_e °F											
	-40	0	40	-20	0	40	-40	0	40	-40	0	40
	R22			R134a			R404A/R507			R407C/R410A		
1	63.9	44.1	28.7	101.4	86.0	59.5	103.6	68.3	41.9	94.8	77.2	55.1
2	127.9	88.2	57.3	202.8	172.0	119.1	207.2	136.7	83.8	189.6	154.3	110.2
3	191.8	132.3	86.0	304.2	257.9	178.6	310.9	205.0	125.7	284.4	231.5	165.4
4	255.7	176.4	114.6	405.7	343.9	238.1	414.5	273.4	167.6	379.2	308.7	220.5

Drying Capacity is expressed during drying in:

- R22: EDP = 10 ppm W, corresponding to a dew point temperature of -58°F
- R134a: EDP = 50 ppm W, corresponding to a dew point temperature of -34.6°F
- R404A: EDP = 10 ppm W, corresponding to a dew point temperature of -40°F
- R407C: EDP = 10 ppm W, corresponding to a dew point temperature of -40°F

Model	Refrigerant	Acid adsorb capacity (drops)	Acid capacity (grams)
S-848-C (80%/20% MS/AA)	R134a	196	10.24
	R410A	232	12.12
S-848-CC (47%/48%/5% MS/AA/C)	R134a	465	24.30
	R410A	523	27.33

Test Condition: T = 77°F, TAN = 0.3mgKOH/g of oil, Humidity = 2%

Recommended Plant Capacity in suction line (tons) S-848-CC (Burn Out)

Model Details			Evaporating Temperature t _e °F											
Part No	ODS(inch)	Cores	-40	-4	39.92	-22	-4	39.92	-40	-4	39.92	-40	-4	39.92
			R22			R134a			R404A/R507			R407C/R410A		
SRC-485	5/8	1	0.85	2.45	5.80	0.83	1.48	3.58	0.65	1.96	4.83	0.85	2.45	5.80
SRC-487	7/8	1	1.59	4.44	10.44	1.54	2.73	6.46	1.25	3.55	8.62	1.59	4.44	10.44
SRC-967	7/8	2	1.59	4.46	10.52	1.54	2.73	6.51	1.25	3.55	8.67	1.59	4.46	10.52
SRC-1447	7/8	3	1.82	5.20	11.83	1.74	3.10	7.28	1.39	4.01	9.81	1.82	5.20	11.83
SRC-1927	7/8	4	2.19	5.97	14.19	2.10	3.70	8.73	1.68	4.81	11.77	2.19	5.97	14.19
SRC-489	1 1/8	1	2.16	5.97	13.99	2.08	3.67	8.70	1.65	4.75	11.52	2.16	5.97	13.99
SRC-969	1 1/8	2	2.33	6.57	15.58	2.25	4.01	9.58	1.82	5.26	12.85	2.33	6.57	15.58
SRC-1449	1 1/8	3	2.36	6.71	15.30	2.25	4.01	9.41	1.82	5.18	12.71	2.36	6.71	15.30
SRC-1929	1 1/8	4	2.84	7.73	18.43	2.73	4.81	11.26	2.19	6.23	15.30	2.84	7.73	18.43
SRC-4811	1 3/8	1	2.70	7.36	17.09	2.59	4.55	10.66	2.08	5.89	14.02	2.70	7.37	17.09
SRC-9611	1 3/8	2	3.16	8.84	20.96	3.01	5.40	12.94	2.45	7.08	17.29	3.16	8.84	20.96
SRC-14411	1 3/8	3	3.50	10.07	24.37	3.36	6.09	14.87	2.73	8.13	20.25	3.50	10.07	24.37
SRC-19211	1 3/8	4	3.84	10.81	25.73	3.70	6.60	15.84	3.01	8.70	21.27	3.84	10.81	25.73
SRC-4813	1 5/8	1	2.56	6.99	16.21	2.45	4.29	10.12	1.96	5.57	13.28	2.56	7.00	16.21
SRC-9613	1 5/8	2	3.61	10.21	24.37	3.47	6.23	14.99	2.82	8.19	20.13	3.61	10.21	24.37
SRC-14413	1 5/8	3	3.30	9.53	23.06	3.19	5.74	14.08	2.59	7.68	19.16	3.30	9.53	23.06
SRC-19213	1 5/8	4	4.41	12.48	29.86	4.27	7.59	18.34	3.44	10.04	24.71	4.41	12.48	29.86
SRC-4817	2 1/8	1	2.62	7.14	16.55	2.50	4.41	10.32	2.02	5.72	13.56	2.62	7.14	16.55
SRC-9617	2 1/8	2	3.53	9.98	23.83	3.41	6.09	14.64	2.76	8.02	19.71	3.53	9.98	23.83
SRC-14417	2 1/8	3	3.13	8.99	21.75	2.99	5.43	13.25	2.42	7.25	18.08	3.13	8.99	21.75
SRC-19217	2 1/8	4	4.35	12.34	29.52	4.21	7.51	18.14	3.41	9.92	24.43	4.35	12.34	29.52
SRC-4821	2 5/8	1	2.62	7.17	16.61	2.53	4.41	10.38	2.02	5.72	13.62	2.62	7.17	16.61
SRC-9621	2 5/8	2	3.44	9.67	23.06	3.30	5.89	14.19	2.67	7.76	19.05	3.44	9.67	23.06
SRC-14421	2 5/8	3	3.30	9.53	23.06	3.19	5.74	14.08	2.59	7.68	19.17	3.30	9.53	23.06
SRC-19221	2 5/8	4	4.18	11.89	28.35	4.07	7.25	17.43	3.30	9.55	23.46	4.18	11.89	28.35

Recommended plant capacity is based on:
 Evaporating temperature of t_e = +39.92°F
 Condensing temperature of t_c = +89.96°F

Drier Cores

Part No	Material	Description	Suitability
S-848-CM	100% MS	High Drying Capacity	HCFC, HFC & CO ₂ Refrigerants
S-848-C	80%/20% MS/AA	Moisture & Acid Absorption	Not suitable for oils containing additives
S-848-CC	47%/48%/5% MS/AA/C	Burn-Out Core	Not suitable for oils containing additives
S-848-SC	100% MS	Low Pressure Drop	HCFC, HFC & CO ₂ Refrigerants
S-848-F	Filter Element	Low Pressure Drop	All applications

REPLACEABLE CARTRIDGE FILTER-DRIER

Tee-Flow Type

The function of a Tee Flow Filter-Drier is to remove moisture and debris from a refrigerant system. A built in Dri-Vue Moisture Indicator provides visual indication of moisture level in the system.

Applications

Henry Technologies' Replaceable Cartridge Tee Flow Filter-Driers are designed for use on refrigeration and air conditioning systems where filtration and drying is desired. The all-in-one unit is composed of a forged brass Tee flow body with ODS/IDS connections, a replaceable Dri-Vue moisture indicating cap, and a screw-on replaceable Filter-Drier Cartridge.

Henry Technologies' Tee-Flow Filter-Driers are suitable for use with HFC and HCFC refrigerants and their associated oils. The Dri-Vue Moisture indicator is designed for use with specific HFC and HCFC refrigerants and their associated oils as listed in the Dri-Vue Color Table.

Main Features

- Patented Henry Technologies' Design*
- ODS/IDS connections
- Positive color contrast: Yellow = Wet, Green = Dry
- Replaceable cap with built-in Moisture Indicator. Part Number MI-3
- Replaceable Filter-Drier Cartridge. Part number 815030
- XH-9 drier desiccant

Technical Specifications

Maximum working pressure = 500 PSI (34.4 Bar)
Allowable operating temperature = +15°F to +200°F (-10°C to +93°C)

*US Patent # 5,852,937



Materials of Construction

The Tee flow body is made of forged brass. The Dri-Vue moisture indicating cap is made of plated steel with a hermetically sealed soda lime glass lens. The cap seal is made of Teflon. The Filter-Drier Cartridge is made of steel, Nylon, Teflon, XH-9 desiccant, and synthetic rubber.

Installation - Notes

1. The brass body must be installed in accordance with the flow direction arrow.
2. Moisture indicating cap must be removed for brazing.
3. Full instructions are given in the Product Instruction Sheet, included with each unit.

- ☐ Inlet
- ⊙ Outlet

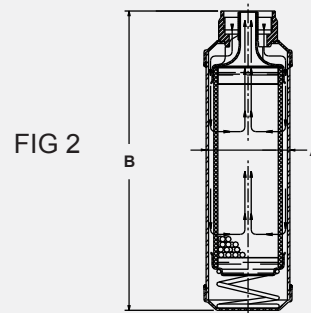
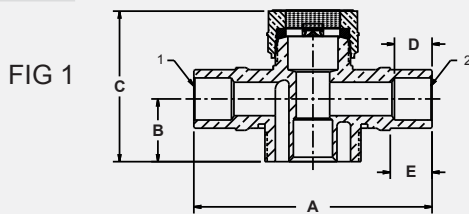

Part No	Fig No	ODS (inch)	IDS (inch)	Dimensions (inch)					Weight (lbs)
				A	B	C	D	E	
850005	1	5/8	7/8	3.56	0.94	2.25	0.56	0.63	0.90

Part No	Fig No	Dimensions (inch)		Filter Area (in ²)	Filter Volume (in ³)	Recommended Drying Capacity (Tons)		Maximum Flow Capacity* (Tons)		Acid Capacity Rating** (drops of water)				Weight (lbs)
		A	B			R22	R502	R22	R502	R22		R502		
										75°F	125°F	75°F	125°F	
815030	2	2.50	8.91	38.50	15.60	12.50	7.50	14.4	10.0	395.0	303.0	410.0	310.0	2.4

*Maximum Flow capacity based on 2 PSI pressure drop

**Acid capacity rating according to ARI standard 710

Dri-Vue Color Table				
Refrigerant Type	Temp (°F)	Moisture PPM - Indicator color		
		Green	Chartreuse	Yellow
R502	75	below 15	15-50	above 50
	100	below 25	25-90	above 90
	125	below 30	30-120	above 120
R22/R134a	75	below 30	30-120	above 120
	100	below 45	45-180	above 180
	125	below 60	60-240	above 240

FILTER-DRIER CORES

Replaceable Type

Filter-Drier cores are used in Henry Technologies' Replaceable Core Filter-Drier shells to filter debris and remove moisture from refrigeration and air conditions systems.

Applications

Henry Technologies offers three types of cores for use in a variety of refrigeration and air conditioning applications. Drier, Filter, and Strainer cores are available in many sizes to fit current and discontinued Drier Shells.

Henry Technologies' Replaceable cores are suitable for use with HFC and HCFC refrigerants and their associated oils.

Main Features

DRI-COR - Standard

- 80% molecular sieve and 20% activated alumina
- Absorbs moisture and acid in the system
- Not suitable for oils containing additives

DRI-COR – High Capacity

- 100% molecular sieve
- High drying capacity absorbs moisture in the system

• Burn-Out

- 47% molecular sieve, 48% activated alumina and 5% activated carbon
- High acid absorption
- Suitable for use after Compressor burnout

FIL-COR

- Filter core
- Filtration down to 5 microns
- Used when drying is not needed

Strainer

- 100 Mesh stainless steel core
- Filtration down to 150 microns
- Used when drying is not needed
- Suitable for ammonia



Part No	Type	Drier Shell Dia (inch)	Core Dimensions			Drying Capacity Rating* (drops of water)**		Weight (lbs)
			Length (inch)	Area (in ²)	Volume (in ³)	R22 Liquid Line Temperature		
						75°F	125°F	
S-848-C	Standard DRI-COR	4.75	5.50	N/A	48	460	288	2.00
S-824-CM	High Cap. DRI-COR	3.00	5.81	N/A	24	288	183	1.40
S-848-CM	High Cap. DRI-COR	4.75	5.50	N/A	48	576	365	2.50
S-810-CM	High Cap. DRI-COR	6.00	6.50	N/A	100	1200	760	5.30
S-848-CC	Burn-Out	4.75	5.50	N/A	48	Not for Liquid Line Use***		2.50
S-848-F	FIL-COR	4.75	5.50	64	N/A	Not for Drying Use		0.51
S-810-CF	FIL-COR	6.00	6.50	150	N/A			1.10
S-848-ST	Strainer	4.75	5.50	65	N/A			0.44

*Drying Capacity is based on the following moisture content before and after drying: From 1050 ppm W to 60 ppm W in accordance with ARI 710-86

**20 drops = 1 gram in accordance with ARI 710-86

***S-848-CC is designed for low side use. Drying capacity* is 580 drops of water** at -40°F to 260 drops of water** at +40°F

DRIER CARTRIDGES FOR DISCONTINUED BRASS DRIER SHELLS							
Part No	Type	Drier Shell Dia (inch)	Core Dimensions		Drying Capacity Rating* (drops of water)**		Weight (lbs)
			Length (inch)	Volume (in ³)	R22 Liquid Line Temperature		
					75°F	125°F	
872-NMS	Standard DRI-COR	2.00	5.00	10	117	83	0.67
873-NMS	Standard DRI-COR	3.00	9.00	45	441	314	2.12
876-NMS	Standard DRI-COR	4.50	10.50	109	1069	760	4.81
875-NMS	Standard DRI-COR	5.00	5.00	50	1038	733	3.31

*Drying Capacity is based on the following moisture content before and after drying: From 1050 ppm W to 60 ppm W in accordance with ARI 710-86

**20 drops = 1 gram in accordance with ARI 710-86

STRAINERS

Straight Through

The function of a Strainer is to remove debris from a refrigerant or oil line in order to protect the compressor and other components from damage.

Applications

Henry Technologies offers Straight Through Strainers in ODS and SAE Flare connections for use on air conditioning and refrigeration systems. The Strainers can be used in refrigerant and oil lines to remove large debris. If greater protection is desired, Henry Technologies also offers Filters and Filter-Driers.

Henry Technologies' Strainers are suitable for use with HFC and HCFC refrigerants and their associated oils, as well as other industrial fluids non-corrosive to steel and copper.

Main Features

- 5/8 ODS connections
- 1/4 SAE Flare connections
- Compact design
- Particle retention down to 150 microns
- 100 Mesh stainless steel screen

Technical Specifications

Maximum working pressure = 500 PSI (34.4 Bar)

Allowable operating temperature = -20°F to +300°F (-29°C to +149°C)

Henry Technologies' Straight Through Strainers are UL and C-UL Listed by Underwriters Laboratories, Inc.

Materials of Construction

The shell and caps are made of steel. The ODS or SAE Flare connections are made of plated steel, and the 100 mesh strainer cartridge is made of stainless steel.

Installation - Notes

1. The Strainers must be installed in accordance with the flow direction arrow.
2. Care should be taken to avoid excess heat while brazing the ODS series Strainers.
3. Units should be replaced after a 15 PSI (1 Bar) pressure drop has been detected. It is recommended to install valves on either side of the strainer to ease replacement.



- ❶ Inlet
- ❷ Outlet

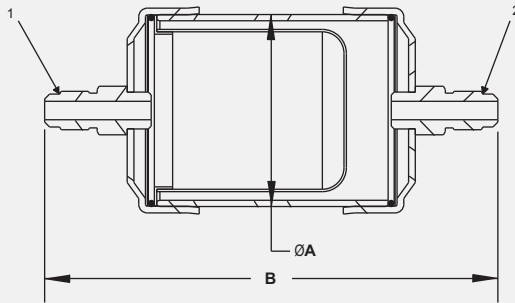

FIG 1

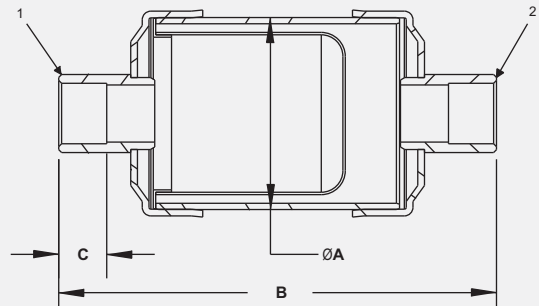

FIG 2

Part No	Fig No	Conn Size (inch)	Dimensions (inch)			Screen Area (in ²)	Weight (lbs)
			ØA	B	C		
891S-1/4	1	1/4 SAE	2.00	4.72	N/A	11.0	0.48
891S-5/8S	2	5/8 ODS	2.00	4.56	0.50	11.0	0.72

STRAINERS

Y-Type

The function of a Strainer is to remove debris from a refrigerant or oil line in order to protect the Compressor and other components from damage.

Applications

Henry Technologies' offers Y-Type Strainers in NPT and ODS connections for use on air conditioning and refrigeration systems. The Strainers can be used in refrigerant and oil lines to remove large debris. If greater protection is desired, Henry Technologies also offers Filters and Filter-Driers.

Henry Technologies' Strainers are suitable for use with HFC and HCFC refrigerants and their associated oils, as well as other industrial fluids non-corrosive to brass, steel and synthetic rubber.

Main Features

- NPT connections
- ODS connections
- Compact design
- Particle retention down to 150 microns
- Replaceable 100 Mesh stainless steel screen

Technical Specifications

Maximum working pressure = 500 PSI (34.4 Bar)

Allowable operating temperature= -20°F to +200°F (-29°C to +93°C)

Henry Technologies' Y-Type Strainers are UL Listed by Underwriters Laboratories, Inc. Additionally, Y-Type Strainers are designed and registered for use in Canada. Please contact Technical Support at 1-800-627-5148 for CRN details and list of approved provinces and territories.

Materials of Construction

The Strainer bodies are made of forged brass and the 100 Mesh strainer cartridge is made of stainless steel. The Strainer Plug is made of brass and uses a synthetic rubber seal.



Installation - Notes

1. The Strainers must be installed in accordance with the flow direction arrow.
2. ODS series Strainers must be taken apart for brazing.
3. Screen Cartridges should be replaced after a 15 PSI (1 Bar) pressure drop has been detected.
4. Full instructions are given in the Product Instruction Sheet, included with each Strainer.

- ❶ Inlet
- ❷ Outlet
- ❸ Strainer Plug

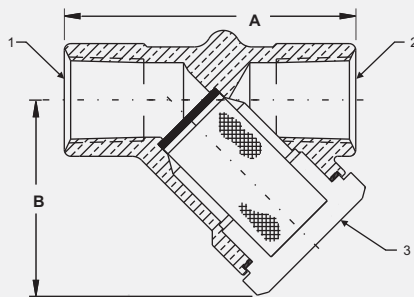

FIG 1

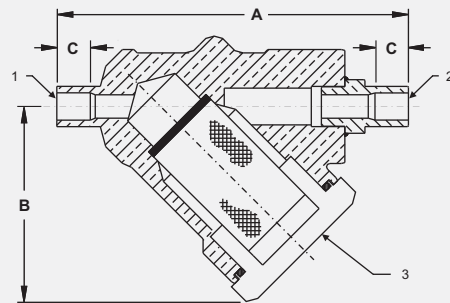

FIG 2

Part No	Fig No	Conn Size (inch)	Dimensions (inch)			Screen Area (in ²)	Weight (lbs)
			A	B	C		
896-1/4PT	1	1/4NPT	2.12	1.62	N/A	2.0	0.55
896-3/8PT	1	3/8 NPT	2.12	1.62	N/A	2.0	0.51
896A-3/8S	2	3/8 ODS	3.38	1.82	0.44	3.0	0.84
896A-1/2S	2	1/2 ODS	3.44	1.82	0.56	3.0	0.82
896A-5/8S	2	5/8 ODS	3.56	1.82	0.63	3.0	0.80
896B-5/8S	2	5/8 ODS	4.50	2.55	0.63	7.0	2.50

SIGHT GLASSES

The function of a Sight Glass is to provide visual indication of fluid level or flow within a vessel or piping system.

Applications

Henry Technologies offers three series of NPT Sight Glasses for use in a variety of refrigeration and industrial applications. The Sight Glasses are available with Clear Lens, Reflex Lens, and Clear Lens with Floating Ball. The Clear Lens design allows for unobstructed visual inspection of fluid level or flow. The Reflex Lens is designed to allow easier fluid level inspection by appearing dark when liquid is present and light when liquid is absent. The Float Ball series is also designed to provide easier inspection of fluid level. The standard Float Ball is made of TPX plastic and will float in an fluid with a specific gravity greater than 0.85.

Henry Technologies' SG-1000 and SG-1100 series Sight Glasses are suitable for use with ammonia, HFC and HCFC refrigerants and their associated oils, as well as other industrial fluids non-corrosive to steel and glass. SG-1200 series Sight Glasses are suitable for use with HFC and HCFC refrigerants and their associated oils, as well as other industrial fluids non-corrosive to steel, glass and TPX plastic.

Main Features

- NPT connection
- Hermetically sealed viewing lens
- High pressure rating
- Plated steel housing
- Three lens configurations for a variety of applications

Technical Specifications

Maximum working pressure = 1000 PSI (68.9 Bar)
 Allowable operating temperature SG-1000, SG-1100 =
 -20°F to +500°F (-29°C to +260°C)
 Allowable operating temperature SG-1200 =
 -20°F to +300°F (-29°C to +149°C)

Henry Technologies' Sight Glasses are USR and CNR recognized by Underwriters Laboratories, Inc. Additionally, all Sight Glasses are designed and registered for use in Canada. Please contact Technical Support at 1-800-627-5148 for CRN details and list of approved provinces and territories. Sight Glasses can be CE marked in accordance with PED by adding a "-CE" suffix to the part number. (i.e. SG-1008-CE)

Materials of Construction

All Sight Glasses feature a plated steel body with hermetically sealed soda lime glass lens. The SG-1200 series Sight Glasses come standard with a TPX plastic Float Ball but are available with an aluminum Float Ball by adding a "C" suffix. (i.e. SG-1208C)

Installation - Notes

1. Install with socket wrench to avoid glass cracking. An open-end wrench should not be used.
2. The user must ensure the Sight Glass is installed with appropriate thread sealant for the application.
3. Full instructions are given in the Product Instruction Sheet, included with each Sight Glass.

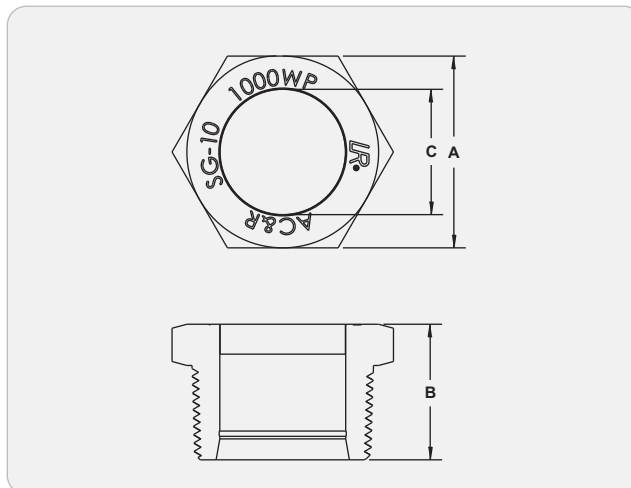
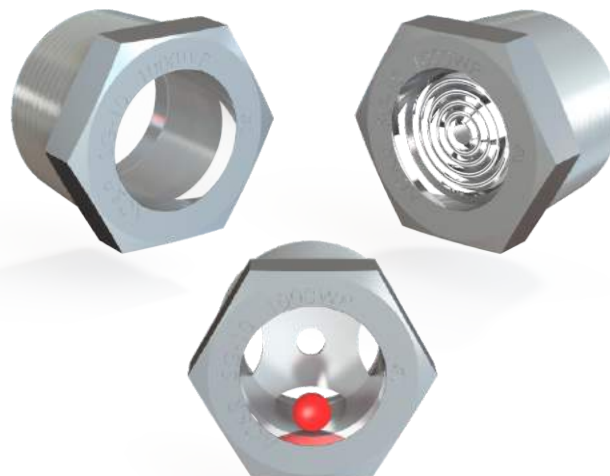

	Part No		NPT (inch)	Dimensions (inch)			CE Cat*	CE Cat Ammonia*	Weight (lbs)	
	Clear	Reflex		Clear with Ball	A (hex)	B				C
	SG-1004	SG-1104	SG-1204	1/2	0.94	0.96	0.56	SEP	SEP	0.13
	SG-1006	SG-1106	SG-1206	3/4	1.12	1.06	0.75	SEP	SEP	0.25
	SG-1008	SG-1108	SG-1208	1	1.38	1.32	0.94	SEP	SEP	0.25
	SG-1010	SG-1110	SG-1210	1-1/4	1.75	1.38	1.19	SEP	CAT II	0.50
	SG-1012	SG-1112	SG-1212	1-1/2	2.00	1.41	1.31	CAT I	CAT II	0.50
	SG-1016	SG-1116	SG-1216	2	2.50	1.42	1.63	CAT I	CAT II	1.00

*Optional Cat I and II CE models available by adding "-CE" suffix to part number. (i.e. SG-1112-CE)

MOISTURE INDICATORS

Dri-Vue, Single and Double Port

The function of a Moisture Indicator is to provide visual indication of moisture level in a refrigerant system.

Applications

Henry Technologies' offers Dri-Vue Moisture Indicators with ODS and SAE Flare connections for use on air conditioning and refrigeration systems. The moisture level in the refrigerant system needs to be monitored to ensure excessive moisture, which could allow harmful acid formation, is not present.

Henry Technologies' Dri-Vue Moisture indicators designed for use with specific HFC and HCFC refrigerants and their associated oils as listed in the Dri-Vue Color Table.

Main Features

- Patented Henry Technologies' Design*
- SAE Flare connections
- ODS connections
- Positive color contrast: Yellow = Wet, Green = Dry
- Replaceable cap with built-in moisture indicator. Part Number MI-3

Technical Specifications

Maximum working pressure = 500 PSI (34.4 Bar)

Allowable operating temperature = +15°F to +200°F (-10°C to +93°C)

Henry Technologies' Moisture Indicators are UL and C-UL Listed by Underwriters Laboratories, Inc.



Materials of Construction

The Moisture Indicator bodies are made of forged brass. The Dri-Vue moisture indicating cap is made of plated steel with a hermetically sealed soda lime glass lens. The cap seal is made of Teflon.

Installation - Notes

1. ODS series Moisture Indicators must be taken apart for brazing.
2. Full instructions are given in the Product Instruction Sheet, included with each Indicator.

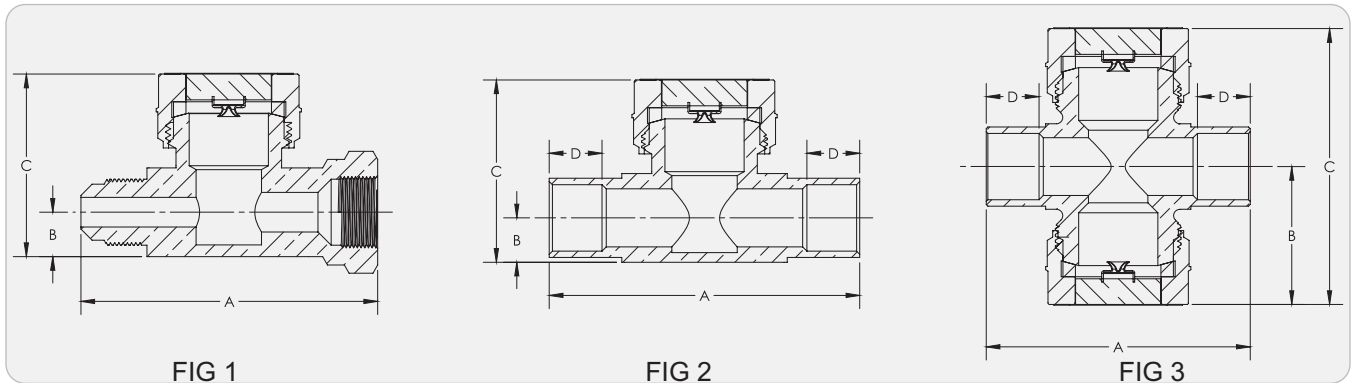

FIG 1

FIG 2

FIG 3

Type	Part No	Fig No	Conn Size (inch)	Dimensions (inch)				Weight (lbs)
				A	B	C	D	
MI-30-F	MI-30-1/4F	1	1/4 SAE Flare	2.63	0.34	1.51	N/A	0.43
	MI-30-3/8F	1	3/8 SAE Flare	2.81	0.45	1.71	N/A	0.57
	MI-30-1/2F	1	1/2 SAE Flare	3.13	0.41	1.65	N/A	0.59
MI-30-S	MI-30-1/4S	2	1/4 ODS	2.63	0.34	1.51	0.31	0.40
	MI-30-3/8S	2	3/8 ODS	2.63	0.34	1.51	0.31	0.41
	MI-30-1/2S	2	1/2 ODS	2.63	0.34	1.51	0.38	0.41
	MI-30-5/8S	2	5/8 ODS	2.94	0.45	1.71	0.50	0.46
MI-31-S	MI-31-5/8S	3	5/8 ODS	2.50	1.30	2.60	0.50	0.69

Dri-Vue Color Table				
Refrigerant Type	Temp (°F)	Moisture PPM - Indicator color		
		Green	Chartreuse	Yellow
R404A	75	below 15	15-90	above 90
	100	below 25	25-115	above 115
	125	below 30	30-140	above 140
R22/R134a	75	below 30	30-120	above 120
	100	below 45	45-180	above 180
	125	below 60	60-240	above 240

LIQUID INDICATORS

Weld-in

The function of a Liquid Indicator is to provide visual indication of fluid level or flow within a vessel or piping system.

Applications

Henry Technologies' Liquid Indicators are used in a variety of refrigeration and industrial applications. The Liquid Indicators feature weld-in housings with a replaceable Sight Glass in clear or Reflex lens. The Clear Lens design allows for unobstructed visual inspection of fluid level or flow while the Reflex lens is designed to allow easier fluid level inspection by appearing dark when liquid is present and light when liquid is absent. The optional Frost Shield allows easy view of the Sight Glass when installed in an application where insulation is used.

Henry Technologies' Liquid Indicators are suitable for use with ammonia, HFC and HCFC refrigerants and their associated oils, as well as other industrial fluids non-corrosive to steel, glass and Teflon.

Main Features

- Patented Henry Technologies' Design*
- Weld-in connection
- Replaceable, hermetically sealed clear or Reflex lens Sight Glass
- Frost shield available for insulated applications
- Plated steel housing

Technical Specifications

Maximum working pressure = 500 PSI (34.4 Bar)

Allowable operating temperature = -40°F to +250°F (-40°C to +121°C)

Henry Technologies' Liquid Indicators are constructed to ASME Section VIII, Division 1 UG-11 (a) (1). Additionally, Liquid Indicators can be CE marked in accordance with PED by adding a "-CE" suffix to the part number. (i.e. LI-50-4W-CE.)



- ① Teflon Seal
- ② Sight Glass
- ③ Optional Frost Shield

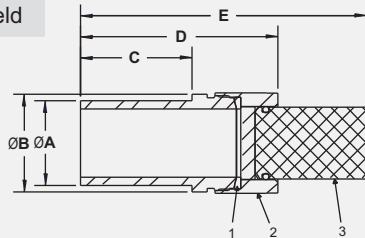

Materials of Construction

The Liquid Indicators body is made of plated steel. The Sight Glass body is plated steel with hermetically sealed soda lime glass lens. The Sight Glass seal is made of Teflon.

Installation - Notes

1. Sight Glass assembly must be removed before welding Liquid Indicator body.
2. A metal protector is supplied to cover the threads on the body to avoid damage by welding spatter.
3. Ensure Liquid Indicator body is cool and clean before installing Sight Glass.
4. Full instructions are given in the Product Instruction Sheet, included with each Liquid Indicator.

Part No	Dimensions (inch)					CE Cat**	Weight (lbs)
	ØA	ØB	C	D	E*		
LI-49-2W	1.90	2.19	0.85	2.67	4.67	CAT I	1.5
LI-49-4W	1.90	2.19	2.50	4.42	6.42	CAT I	2.0
LI-50-2W	1.90	2.19	0.85	2.67	4.67	CAT I	1.5
LI-50-4W	1.90	2.19	2.50	4.42	6.42	CAT I	2.0

*Dimension includes Frost Shield sold separately

**Optional Cat I CE models available by adding "-CE" suffix to part number. (i.e. LI-50-4W-CE)

Accessories and Replacement Parts

Part No	Description
FS-2-1/2	Frost Shield
LI-49A-3AR	Clear Sight Glass
LI-50A-3AR	Reflex Sight Glass
2-023-053	Teflon Seal

LIQUID INDICATORS

Double Port, Cap Type

The function of a Liquid Indicator is to provide visual indication of fluid presence or flow within a piping system.

Applications

Henry Technologies' Liquid Indicators are used in a variety of refrigeration and industrial applications. The LI48 Series Liquid Indicators feature plated iron housings with NPT connections and dual replaceable Sight Glass Caps. The Sight Glass Caps feature hermetically sealed clear glass lenses for easy viewing.

Henry Technologies' LI48 series Liquid Indicators are suitable for use with ammonia, HFC and HCFC refrigerants and their associated oils, as well as other industrial fluids non-corrosive to steel, glass and Teflon.

Main Features

- NPT connections
- Dual replaceable Sight Glasses. Part number LI-3
- Interchangeable with Moisture Indicator Sight Glasses. Part number MI-3
- Plated iron housing

Technical Specifications

Maximum working pressure = 500 PSI (34.4 Bar)

Allowable operating temperature = -20°F to +250°F (-29°C to +121°C)

Materials of Construction

The Liquid Indicators body is made of plated iron. The Sight Glass body is plated steel with hermetically sealed soda lime glass lens. The Sight Glass seal is made of Teflon.

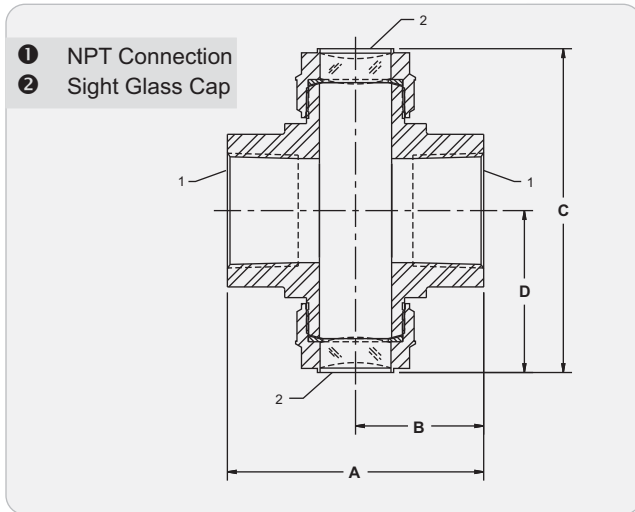

Part No	NPT (inch)	Dimensions (inch)				Weight (lbs)
		A	B	C	D	
LI48A-1/2	1/2	2.94	1.47	3.71	1.86	2.0
LI48A-3/4	3/4	2.94	1.47	3.71	1.86	2.0
LI48A-1	1	2.94	1.47	3.71	1.86	2.0

LIQUID LEVEL SWITCHES

NPT Type

The function of a Liquid Level Switch is to detect and monitor liquid level in a vessel.

Applications

Henry Technologies' Liquid Level Switches are designed for use in a variety of refrigeration and industrial applications. Liquid Level Switches can be installed in Liquid Receivers, Suction Line Accumulators, compressor crankcases, or a variety of other applications, to detect and monitor fluid levels.

Henry Technologies' Liquid Level Switches are suitable for use with ammonia, HFC and HCFC refrigerants and their associated oils, as well as other industrial fluids non-corrosive to steel and glass.

Main Features

- Patented optical sensor technology*
- NPT connection to liquid
- 1/2" conduit connection for wiring
- High and Low Voltage models
- Serviceable without refrigerant loss
- NEMA 4 and 4X approved
- Replacement parts available

How it Works

The Liquid Level Switches use light reflecting from a conical glass prism as a means of detecting the absence of a fluid at the level of the glass cone. When no fluid covers the lower half of the cone, infrared light from the module reflects from the mirror-like inner surface of the cone back to a light detector signaling the electric module to switch. When fluid covers the lower half of the glass cone, the light from the module passes into the fluid. This absence of light is detected by the module which switches into the opposite direction.

Technical Specifications

Maximum working pressure = 1200 PSI (82.7 Bar)

Allowable operating temperature = -40°F to +200°F (-40°C to +93.3°C)

Switch Inductive Rating = 36 VA Pilot Duty Rated

Power for Operation = 3.5 mA AC, 5.5 mA DC

Minimum Load = 2 mA (without bleed resistor)

Henry Technologies' Liquid Level Switches meet the requirements of UL 873 and UL 207 and are USR and CNR recognized by Underwriters Laboratories, Inc. Additionally, Liquid Level Switches are CE marked in accordance with PED.

Materials of Construction

The Level Switch Housing is made of plated steel with hermetically sealed soda lime glass prism. The Level Switch is secured in the housing with a plated steel retainer and sealed with a silicon O-ring.



Installation - Notes

1. Liquid Level Switches must be installed horizontally. Switches cannot be mounted at an angle or vertically.
2. When installed, no objects are to be within 2" of the glass prism.
3. Install Level Switches with a socket wrench to avoid glass cracking. An open-end wrench should not be used.
4. The user must ensure the Liquid Level Switch is installed with appropriate thread sealant for the application.
5. Wiring diagrams are included with the full instructions given in the Product Instruction Sheet, included with each unit.

1 NPT Connection

2 1/2" Conduit Connection

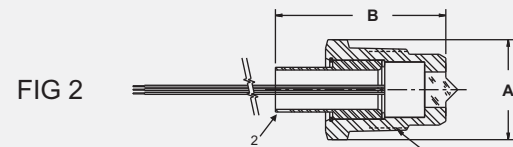
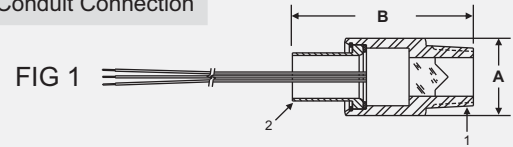

Part No	NPT (inch)	Fig No	Dimensions (inch)	
			A (hex)	B
S-9400 Series	1/2	1	1-1/8	2.55
S-9400-1 Series	1	2	1-3/8	2.73

Part No	Voltage	Resistive Rating (Amp)	Contacts with Liquid Present	Wire color Code	Replacement Module
S-9400	120VAC 50/60 Hz	0.5	Closed	Yellow & White	2-044-012
S-9400-1	120VAC 50/60 Hz	0.5	Closed	Yellow & White	2-044-012
S-9400A	120VAC 50/60 Hz	0.5	Open	Yellow & White/Stripe	2-044-017
S-9400A-1	120VAC 50/60 Hz	0.5	Open	Yellow & White/Stripe	2-044-017
S-9420	208/240VAC 50/60 Hz	0.25	Closed	Red & White	2-044-015
S-9420-1	208/240VAC 50/60 Hz	0.25	Closed	Red & White	2-044-015
S-9420A	208/240VAC 50/60 Hz	0.25	Open	Red & White/Stripe	2-044-018
S-9420A-1	208/240VAC 50/60 Hz	0.25	Open	Red & White/Stripe	2-044-018
S-9424	24 V AC/DC	0.5	Closed	Orange & White	2-044-013
S-9424-1	24 V AC/DC	0.5	Closed	Orange & White	2-044-013
S-9424A	24 V AC/DC	0.5	Open	Orange & White/Stripe	2-044-020
S-9424A-1	24 V AC/DC	0.5	Open	Orange & White/Stripe	2-044-020

LIQUID LEVEL SWITCHES

Sight Glass Type

The function of a Liquid Level Switch is to detect and monitor liquid level in a vessel.

Applications

Henry Technologies' Liquid Level Switches are designed for use in a variety of refrigeration and industrial applications. The E-Series Liquid Level Switches are designed to be used with the Henry Technologies' LI-50 Series Sight Glass. The Sight Glasses and Liquid Level Switches can be installed on Liquid Receivers, Suction Line Accumulators, compressor crankcases, or a variety of other applications, to detect and monitor fluid levels.

Henry Technologies' Liquid Level Switches do not come in contact with the fluid being monitored. However, the LI-50 Series Sight Glasses are suitable for use with ammonia, HFC and HCFC refrigerants and their associated oils, as well as other industrial fluids non-corrosive to steel and glass.

Main Features

- Patented optical sensor technology*
- Installed on existing Sight Glasses
- 1/2" conduit connection for wiring
- High and Low Voltage models
- Serviceable without refrigerant loss
- Replacement parts available

How it Works

The Liquid Level Switches use light reflecting from a conical glass prism as a means of detecting the absence of a fluid at the level of the glass cone. When no fluid covers the lower half of the cone, infrared light from the module reflects from the mirror-like inner surface of the cone back to a light detector signaling the electric module to switch. When fluid covers the lower half of the glass cone, the light from the module passes into the fluid. This absence of light is detected by the module which switches into the opposite direction.

Technical Specifications

Maximum working pressure LI-50 = 500 PSI (34.4 Bar)

Allowable operating temperature = -40°F to +200°F (-40°C to +93.3°C)

Switch Inductive Rating = 36 VA Pilot Duty Rated

Power for Operation = 3.5 mA AC, 5.5 mA DC

Minimum Load = 2 mA (without bleed resistor)

Henry Technologies' Liquid Level Switches meet the requirements of UL 873 and UL 207 and are USR and CNR recognized by Underwriters Laboratories, Inc. Additionally, Liquid Level Switches are CE marked in accordance with PED.

Materials of Construction

The Level Switch Housing is made of Lucite and is sealed with a synthetic rubber O-ring.



Installation - Notes

1. E-9400 Series Liquid Level Switches are installed using and existing LI-50 Series Sight Glass.
2. The Liquid Level Switch must be installed so that the module is touching the Sight Glass face.
3. The Sight Glass and Liquid Level Switch must be installed horizontally. Switches cannot be mounted at an angle or vertically.
4. Wiring diagrams are included with the full instructions given in the Product Instruction Sheet, included with each unit.

- 1 Lucite Body
- 2 1/2" Conduit Connection

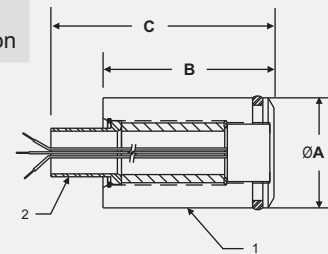

Part No	Connection	Dimensions (inch)		
		ØA	B	C
E-9400 Series	LI-50-3AR	1.61	2.5	3.26

Part No	Voltage	Resistive Rating (Amp)	Contacts with Liquid Present	Wire color Code	Replacement Module
E-9400	120VAC 50/60 Hz	0.5	Closed	Yellow & White	2-044-012
E-9400A	120VAC 50/60 Hz	0.5	Open	Yellow & White/Stripe	2-044-017
E-9420	208/240VAC 50/60 Hz	0.25	Closed	Red & White	2-044-015
E-9420A	208/240VAC 50/60 Hz	0.25	Open	Red & White/Stripe	2-044-018
E-9424	24 V AC/DC	0.5	Closed	Orange & White	2-044-013
E-9424A	24 V AC/DC	0.5	Open	Orange & White/Stripe	2-044-020

LIQUID AND OIL LEVEL PROBES

The function of a Liquid Level Probe is to measure and display refrigerant or oil level in a vessel.

Applications

Henry Technologies' Liquid Level Probes are designed for use in a variety of refrigeration and air conditioning applications. The Liquid Level Probes use a 3/4" MPT or a 1-1/4"-12 Rotalock fitting to mount to Liquid Receivers or Oil Reservoirs and provide a 0-5V output of fluid level. Probes are custom ordered based on specific application and desired features.

Henry Technologies' Liquid Level Probes are suitable for use with HFC, HCFC and CO₂ refrigerants, as well as their associated oils. Each Probe should be ordered based on specific application to ensure proper calibration.

Main Features

- 3/4" MPT or 1-1/4"-12 Rotalock connection
- Continuous accurate measurement
- DIN cable connector
- 6ft, 3-wire 20 AWG cable
- Options Include:
 - LCD Display
 - Stand tube (essential for horizontal vessels or vertical vessels with internal elements such as dip tubes or heater coils)
 - Remote probe head
 - 0-5V or 1-6V output
 - 12ft cable

How it Works

The Liquid Level Probe measures refrigerant or oil level by sensing a change in capacitance between the LLP probe rod and the receiver/reservoir wall. As the fluid changes in level, the output voltage changes between 0 and 5 volts. For example, at the 0% set level the output would read 0V, at the 50% set level the output would read 2.5V, and at the 100% mark (Typically set at 90% of vessel capacity) the output would read 5V. All Liquid Level Probes come factory calibrated based on the order specification but are easily recalibrated in the field if needed.

Technical Specifications

Maximum working pressure = 1305 PSI (90 Bar)
 Allowable ambient temperature = -40°F to +158°F (-40°C to +70°C)
 Supply Voltage = 12-32 VDC
 Maximum Load = up to 2 K ohms with less than a 5% shift

Henry Technologies' Liquid Level Probes are CE marked in accordance with PED.

*Please contact Henry Technologies' Sales Department at 1-800-964-3679 for custom applications.

Materials of Construction

The probe rod is made of stainless steel and the stand tube is made of aluminum. The Rotalock connection is made of plated steel, and the probe head is cast aluminum.

Installation - Notes

1. Liquid Level Probes are factory calibrated based on order specifications.
2. Re-calibration procedure and wiring diagrams are included with the full instructions given in the Product Instruction Sheet, supplied with each unit.



- 1 3-Wire Cable
- 2 DIN Cable Connector
- 3 Backlit LCD Display (optional)
- 4 Mounting Connection
- 5 Probe Rod & Stand Tube (optional)

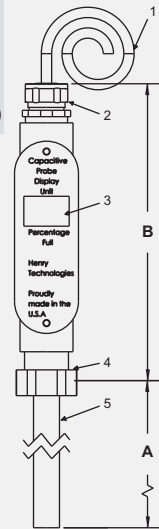

Part No	Conn Size (inch)	Dimensions (inch)		Weight (lbs)
		A	B	
LLP Series	3/4" MPT or 1-1/4"-12 Rotalock	10-60	7.75	2.5

LIQUID REFRIGERANT RECEIVERS

Vertical, UL

The function of a Liquid Refrigerant Receiver is to store liquid refrigerant to provide continuous flow of liquid refrigerant to the expansion device and to provide storage for the refrigerant charge during system service or maintenance.

Applications

Liquid Refrigerant Receivers are installed in air conditioning and refrigeration systems. The Receiver is installed after the Condenser in order to collect the condensed refrigerant to allow a continuous liquid supply to the expansion device. Liquid Receivers are also used to store the refrigerant charge while the system is pumped down for service or maintenance.

Henry Technologies' Liquid Refrigerant Receivers are suitable for use with HFC and HCFC refrigerants and their associated oils, as well as other industrial fluids non-corrosive to steel, copper and Teflon.

Main Features

- SAE flare inlet connections
- SAE flare Rotalock Valve outlet connection
- Integral fusible rivet or fusible plug on select models
- Mounting stud or legs on all models
- Custom models available upon request

Technical Specifications

Maximum working pressure = 450 PSI (31 Bar)

Allowable operating temperature = 0°F to +250°F (-18°C to +121°C)

Henry Technologies' Liquid Refrigerant Receivers are UL and C-UL Listed by Underwriters Laboratories, Inc. Additionally, Liquid Receivers are designed and registered for use in Canada. Please contact Technical Support at 1-800-627-5148 for CRN details and list of approved provinces and territories.

Materials of Construction

The shell and caps are made of steel. The flare connection, Rotalock Valve and mounting stud are made of plated steel.

Selection Guidelines

Receiver storage capacities are based on the liquid occupying no more than 90% of the internal volume when the temperature of the refrigerant is 90°F (32°C) per ASHRAE Standard 15-78. Receivers should be selected based on the operating charge for all system components, including the liquid lines. It is usual to add a small percentage to cover the refrigerant in long runs of suction and discharge lines, etc. It is essential that the maximum operating charge be determined, e.g., winter charge in air cooled condenser having flooded head pressure control, this being much greater than the normal summer charge.

Installation - Notes

1. Install the Liquid Refrigerant Receiver after the Condenser and before the Liquid Line Filter-Drier.
2. An integral Fusible Rivet is included on select models to protect the vessel from over-pressure due to excessive heat. Replace the Receiver immediately if the stamped temperature rating is exceeded.
3. An 1/8 NPT Fusible Plug is included on select models to protect the vessel from over-pressure due to excessive heat. Replace the Fusible Plug immediately if the stamped temperature rating is exceeded.



- ❶ SAE Flare Inlet
- ❷ Rotalock Valve SAE Flare Outlet
- ❸ 3/8" - 16 Mounting Stud
- ❹ Ø 0.38"x 0.63" Mounting Slot

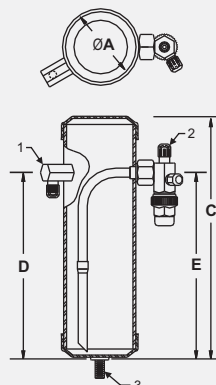

FIG 1

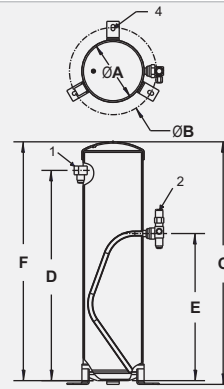

FIG 2

Part No	Fig No	Conn SAE Flare		Dimensions (inch)						Pump Down Capacity* (lbs)			Weight (lbs)
		Inlet	Outlet	ØA	ØB**	C	D	E	F	R134a	R22	R404A/R507	
S-8060	1	1/4	1/4	3.0	N/A	10.0	7.63	7.63	N/A	2.4	2.4	2.0	2.0
S-8061	1	1/4	1/4	3.5	N/A	7.5	5.13	5.13	N/A	2.4	2.4	2.1	2.0
S-8062	1	1/4	1/4	3.5	N/A	10.0	7.63	7.63	N/A	3.3	3.3	2.8	3.0
S-8063	1	1/4	1/4	4.0	N/A	10.0	7.63	7.63	N/A	4.3	4.2	3.7	4.0
S-8064	1	1/4	1/4	5.0	N/A	10.0	6.75	6.75	N/A	6.7	6.6	5.7	6.0
S-8065	1	3/8	3/8	6.0	N/A	12.0	8.00	8.00	N/A	11.6	11.5	10.0	10.0
S-8066	1	3/8	1/2	6.0	N/A	18.0	15.00	14.50	N/A	17.6	17.3	15.0	16.0
S-8067	2	1/2	1/2	6.0	8.75	24.0	21.25	14.88	23.60	23.5	23.2	20.1	21.0
S-8068	2	5/8	5/8	6.0	8.75	30.0	27.25	14.88	29.63	29.4	29.1	25.2	26.0

*All Pump Down Capacities calculated at 90% of receiver volume at 90°F (32°C)

** (3) Ø 0.38" X 0.63" Mounting slots equally spaced on bolt circle.

LIQUID REFRIGERANT RECEIVERS

Horizontal, UL



The function of a Liquid Refrigerant Receiver is to store liquid refrigerant to provide continuous flow of liquid refrigerant to the expansion device and to provide storage for the refrigerant charge during system service or maintenance.

Applications

Liquid Refrigerant Receivers are installed in air conditioning and refrigeration systems. The Receiver is installed after the Condenser in order to collect the condensed refrigerant to allow a continuous liquid supply to the expansion device. Liquid Receivers are also used to store the refrigerant charge while the system is pumped down for service or maintenance.

Henry Technologies' Liquid Refrigerant Receivers are suitable for use with HFC and HCFC refrigerants and their associated oils, as well as other industrial fluids non-corrosive to steel, copper and Teflon.

Main Features

Standard Series

- ODS connections
- 3/8 NPT relief device fitting
- Custom models available upon request

V-Series

- ODS Rotalock Valve connections
- Horizontal mounting brackets
- 3/8 NPT relief device fitting
- Custom models available upon request

Technical Specifications

Maximum working pressure = 450 PSI (31 Bar)

Allowable operating temperature = 0°F to +250°F (-18°C to +121°C)

Henry Technologies' Liquid Refrigerant Receivers are UL and C-UL Listed by Underwriters Laboratories, Inc. Additionally, Liquid Receivers are designed and registered for use in Canada. Please contact Technical Support at 1-800-627-5148 for CRN details and list of approved provinces and territories.

Materials of Construction

The shell and caps are made of steel. The ODS connections and ODS Rotalock Valve are made of plated steel.

Selection Guidelines

Receiver storage capacities are based on the liquid occupying no more than 90% of the internal volume when the temperature of the refrigerant is 90°F (32°C) per ASHRAE Standard 15-78. Receivers should be selected based on the operating charge for all system components, including the liquid lines. It is usual to add a small percentage to cover the refrigerant in long runs of suction and discharge lines, etc. It is essential that the maximum operating charge be determined, e.g., winter charge in air cooled condenser having flooded head pressure control, this being much greater than the normal summer charge.

Installation - Notes

1. Install the Liquid Refrigerant Receiver after the Condenser and before the Liquid Line Filter-Drier.
2. An NPT fitting is provided at the top of the vessel for installation of a pressure relief device. The user must ensure the vessel is protected from over-pressure.

- ❶ Inlet
- ❷ Outlet
- ❸ 3/8" NPT Relief Device Fitting
- ❹ 0.44" Mounting Holes

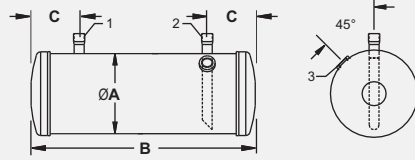

FIG 1

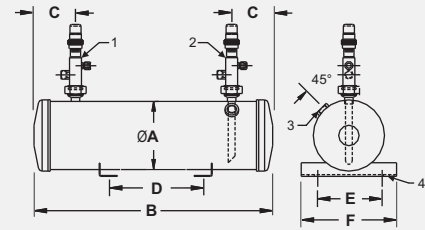

FIG 2

STANDARD SERIES

Part No	Fig No	ODS (inch)		Dimensions (inch)			Pump Down Capacity* (lbs)			Weight (lbs)
		Inlet	Outlet	ØA	B	C	R134a	R22	R404A/R507	
S-8600	1	5/8	5/8	5.0	28.0	3.00	18.8	18.6	16.2	19.0
S-8610	1	5/8	5/8	5.0	36.0	3.00	24.3	24.0	20.9	25.0
S-8620	1	5/8	5/8	6.0	30.0	3.63	29.2	28.8	25.0	24.0
S-8630	1	5/8	5/8	6.0	36.0	3.63	35.0	34.6	30.1	28.0

*All Pump Down Capacities calculated at 90% of receiver volume at 90°F (32°C)

V-SERIES

Part No	Fig No	ODS (inch)		Dimensions (inch)						Pump Down Capacity* (lbs)			Weight (lbs)
		Inlet	Outlet	ØA	B	C	D	E	F	R134a	R22	R404A/R507	
S-8600V	2	1/2	1/2	5.0	28.0	3.00	14.00	5.50	7.00	2.4	2.4	2.0	19.0
S-8630V	2	1/2	1/2	6.0	36.0	3.63	18.00	5.50	7.00	2.4	2.4	2.1	28.0

*All Pump Down Capacities calculated at 90% of receiver volume at 90°F (32°C)

LIQUID REFRIGERANT RECEIVERS

Vertical, ASME

The function of a Liquid Refrigerant Receiver is to store liquid refrigerant to provide continuous flow of liquid refrigerant to the expansion device and to provide storage for the refrigerant charge during system service or maintenance.

Applications

Liquid Refrigerant Receivers are installed in air conditioning and refrigeration systems. The Receiver is installed after the Condenser in order to collect the condensed refrigerant to allow a continuous liquid supply to the expansion device. Liquid Receivers are also used to store the refrigerant charge while the system is pumped down for service or maintenance.

Henry Technologies' Liquid Refrigerant Receivers are suitable for use with ammonia, HFC and HCFC refrigerants and their associated oils, as well as other industrial fluids non-corrosive to steel.

Main Features

- ODS refrigerant connections
- NPT relief device fitting
- (3) 1/2 NPT fittings for sight glasses or level switches on 14" diameter and larger
- Mounting legs on all models
- Custom models available upon request

Technical Specifications

Maximum working pressure = 450 PSI (31 Bar)

Allowable operating temperature = -20°F to +250°F (-29°C to +121°C)

Henry Technologies' Liquid Refrigerant Receivers are constructed to ASME Section VIII. Additionally, Liquid Receivers are designed and registered for use in Canada. Please contact Technical Support at 1-800-627-5148 for CRN details and list of approved provinces and territories.

Materials of Construction

The shell and caps are made of steel. The ODS connections are made of plated steel and the mounting legs are made of carbon steel.

Selection Guidelines

Receiver storage capacities are based on the liquid occupying no more than 90% of the internal volume when the temperature of the refrigerant is 90°F (32°C) per ASHRAE Standard 15-78. Receivers should be selected based on the operating charge for all system components, including the liquid lines. It is usual to add a small percentage to cover the refrigerant in long runs of suction and discharge lines, etc. It is essential that the maximum operating charge be determined, e.g., winter charge in air cooled condenser having flooded head pressure control, this being much greater than the normal summer charge.

Installation - Notes

1. Install the Liquid Refrigerant Receiver after the Condenser and before the Liquid Line Filter-Drier.
2. An NPT fitting is provided at the top of the vessel for installation of a pressure relief device. The user must ensure the vessel is protected from over-pressure.



- ❶ ODS Inlet
- ❷ ODS Outlet
- ❸ NPT Relief Device Fitting
- ❹ Ø 0.56" X 0.88" Mounting Slot
- ❺ 1/2" NPT Fitting

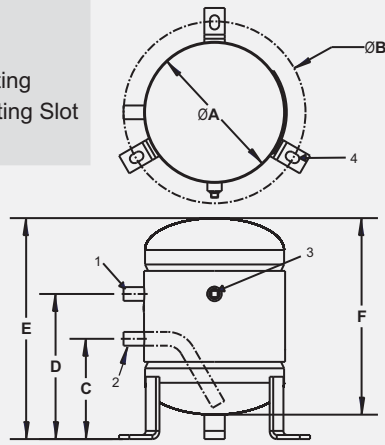

FIG 1

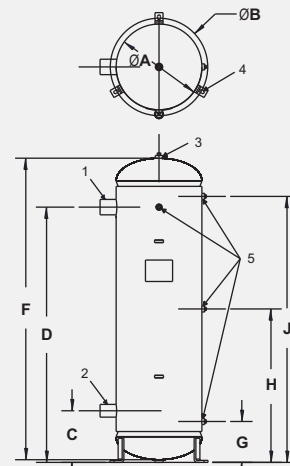

FIG 2

Part No	Fig No	ODS (inch)		NPT Relief	Dimensions (inch)									Weight (lbs)
		Inlet	Outlet		ØA	ØB*	C	D	E	F	G	H	J	
S-8490	1	5/8	5/8	3/8	6.625	9.12	6.13	11.88	16.50	15.00	N/A	N/A	N/A	20.0
S-8500	1	5/8	5/8	3/8	8.625	11.12	6.13	8.87	13.51	12.02	N/A	N/A	N/A	29.0
S-8510	1	5/8	5/8	1/2	8.625	11.12	5.86	12.65	16.96	15.46	N/A	N/A	N/A	35.0
S-8520	1	1-1/8	7/8	1/2	10.75	13.25	7.25	12.25	18.75	18.00	N/A	N/A	N/A	60.0
S-8530	1	1-1/8	1-1/8	1/2	12.75	15.25	7.31	12.31	18.88	18.13	N/A	N/A	N/A	86.0
S-8540	1	1-1/8	1-1/8	1/2	12.75	15.25	7.31	14.31	20.88	20.13	N/A	N/A	N/A	96.0
S-8550	1	1-1/8	1-1/8	1/2	12.75	15.25	7.31	18.31	24.88	24.13	N/A	N/A	N/A	113.0
S-8551	1	1-3/8	1-3/8	1/2	12.75	15.25	7.51	30.51	37.27	36.52	N/A	N/A	N/A	163.0
S-8552	1	1-5/8	1-5/8	1/2	12.75	15.25	7.25	42.25	48.75	48.00	N/A	N/A	N/A	211.0
S-8561	2	1-5/8	1-5/8	3/4	14.0	16.50	9.50	39.50	49.00	48.00	13.29	24.12	34.95	195.0
S-8562	2	2-1/8	1-5/8	3/4	14.0	16.50	9.50	51.50	61.00	60.00	9.50	30.50	51.50	241.0
S-8571	2	2-5/8	2-1/8	3/4	16.0	18.50	9.50	47.50	57.00	56.00	7.50	28.50	49.50	330.0
S-8572	2	2-5/8	2-1/8	3/4	16.0	18.50	9.50	52.50	61.00	60.00	9.50	30.50	52.50	351.0
S-8573	2	2-5/8	2-1/8	3/4	16.0	18.50	9.50	59.50	69.00	68.00	13.50	34.50	55.50	393.0
S-8582	2	2-5/8	2-1/8	3/4	18.0	20.50	9.50	41.50	61.00	60.00	9.50	30.00	41.50	398.0

*(3) Ø 0.56" X 0.88" Mounting slots equally spaced on bolt circle

Part No	Internal Volume (ft ³) at 90%	Pump Down Capacity* (lbs)			
		R134a	R22	R404A	R407C
S-8490	0.22	16.20	16.00	13.90	15.50
S-8500	0.29	21.20	20.90	18.10	20.30
S-8510	0.40	29.30	28.90	25.10	28.10
S-8520	0.69	50.60	49.90	43.20	48.50
S-8530	0.96	70.90	69.80	60.50	67.90
S-8540	1.09	79.90	78.70	68.20	76.50
S-8550	1.33	97.90	96.50	83.70	93.90
S-8551	2.07	152.10	19.90	130.00	145.80
S-8552	2.80	206.30	203.40	176.30	197.70
S-8561	3.33	244.80	241.20	209.10	234.50
S-8562	4.20	309.40	304.90	264.40	296.50
S-8571	5.16	379.60	374.10	324.30	363.70
S-8572	5.54	408.00	402.10	348.60	391.00
S-8573	6.32	464.90	458.20	397.30	445.50
S-8582	6.91	508.40	501.10	434.40	487.20

*All Pump Down Capacities calculated at 90% of receiver volume at 90°F (32°C)

LIQUID REFRIGERANT RECEIVERS

Horizontal, ASME



The function of a Liquid Refrigerant Receiver is to store liquid refrigerant to provide continuous flow of liquid refrigerant to the expansion device and to provide storage for the refrigerant charge during system service or maintenance.

Applications

Liquid Refrigerant Receivers are installed in air conditioning and refrigeration systems. The Receiver is installed after the Condenser in order to collect the condensed refrigerant to allow a continuous liquid supply to the expansion device. Liquid Receivers are also used to store the refrigerant charge while the system is pumped down for service or maintenance.

Henry Technologies' Liquid Refrigerant Receivers are suitable for use with ammonia, HFC and HCFC refrigerants and their associated oils, as well as other industrial fluids non-corrosive to steel.

Main Features

- ODS refrigerant connections
- NPT relief device fitting
- Bare receiver without mounting brackets
- Custom models available upon request

Technical Specifications

Maximum working pressure = 450 PSI (31 Bar)

Allowable operating temperature = -20°F to +250°F (-29°C to +121°C)

Henry Technologies' Liquid Refrigerant Receivers are constructed to ASME Section VIII. Additionally, Liquid Receivers are designed and registered for use in Canada. Please contact Technical Support at 1-800-627-5148 for CRN details and list of approved provinces and territories.

Materials of Construction

The shell and caps are made of steel and the ODS connections are made of plated steel.

Selection Guidelines

Receiver storage capacities are based on the liquid occupying no more than 90% of the internal volume when the temperature of the refrigerant is 90°F (32°C) per ASHRAE Standard 15-78. Receivers should be selected based on the operating charge for all system components, including the liquid lines. It is usual to add a small percentage to cover the refrigerant in long runs of suction and discharge lines, etc. It is essential that the maximum operating charge be determined, e.g., winter charge in air cooled condenser having flooded head pressure control, this being much greater than the normal summer charge.

Installation - Notes

1. Install the Liquid Refrigerant Receiver after the Condenser and before the Liquid Line Filter-Drier.
2. An NPT fitting is provided at the top of the vessel for installation of a pressure relief device. The user must ensure the vessel is protected from over-pressure.

- ❶ ODS Inlet
- ❷ ODS Outlet
- ❸ NPT Relief Device Fitting

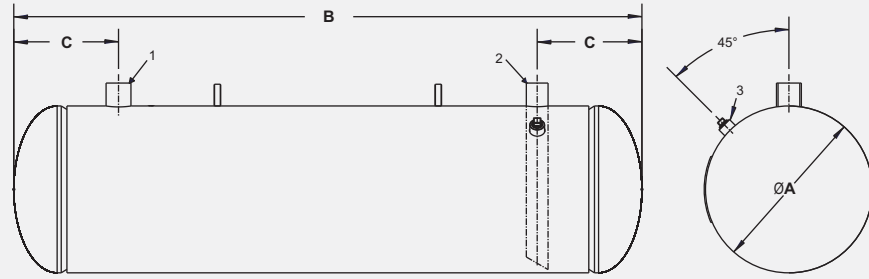

Part No	ODS (inch)		Dimensions (inch)			Pump Down Capacity* (lbs)				Internal Volume (ft ³) at 90%	Weight (lbs)
	Inlet	Outlet	ØA	B	C	R134a	R22	R404A	R407		
S-8639	7/8	7/8	6.63	36.0	4.63	40.9	40.3	34.9	39.2	0.56	44
S-8640	1-1/8	7/8	8.63	36.0	4.63	70	69	59.8	37.1	0.95	65
S-8650	1-1/8	7/8	8.63	42.0	4.63	82.2	81.1	70.3	78.8	1.12	71
S-8660	1-1/8	1-1/8	8.63	48.0	4.63	94.4	93.1	80.7	90.5	1.28	77
S-8670	1-1/8	1-1/8	8.63	60.0	4.63	118.8	117.1	101.5	113.8	1.61	108
S-8680	1-1/8	1-1/8	8.63	72.0	4.63	142.9	140.8	122.1	136.9	1.94	127
S-8690	1-3/8	1-3/8	10.75	36.0	6.50	106.9	105.3	91.3	102.4	1.45	115
S-8700	1-3/8	1-3/8	10.75	48.0	6.50	144.8	142.7	123.7	138.8	1.97	138
S-8710	1-3/8	1-3/8	10.75	60.0	6.50	182.8	180.1	156.2	175.1	2.48	166
S-8720	1-3/8	1-3/8	10.75	72.0	6.50	220.7	217.5	188.6	211.5	3.00	196
S-8730	1-5/8	1-3/8	10.75	84.0	6.50	258.7	254.9	221	247.9	3.52	255
S-8740	1-5/8	1-3/8	10.75	96.0	6.50	296.6	292.3	253.4	284.2	4.03	288
S-8750	1-5/8	1-3/8	12.75	48.0	8.00	205.4	202.4	175.5	196.8	2.79	128
S-8760	1-5/8	1-3/8	12.75	60.0	8.00	259.5	255.8	221.7	248.7	3.53	218
S-8770	2-1/8	1-3/8	12.75	72.0	8.00	313.7	309.2	268.0	300.6	4.26	260
S-8780	2-1/8	1-3/8	12.75	96.0	8.00	422.1	416.0	360.7	404.5	5.74	360

*All Pump Down Capacities calculated at 90% of receiver volume at 90°F (32°C)

LIQUID REFRIGERANT RECEIVERS

Horizontal, ASME



The function of a Liquid Refrigerant Receiver is to store liquid refrigerant to provide continuous flow of liquid refrigerant to the expansion device and to provide storage for the refrigerant charge during system service or maintenance.

Applications

Liquid Refrigerant Receivers are installed in air conditioning and refrigeration systems. The Receiver is installed after the Condenser in order to collect the condensed refrigerant to allow a continuous liquid supply to the expansion device. Liquid Receivers are also used to store the refrigerant charge while the system is pumped down for service or maintenance.

Henry Technologies' Liquid Refrigerant Receivers are suitable for use with ammonia, HFC and HCFC refrigerants and their associated oils, as well as other industrial fluids non-corrosive to steel and Teflon.

Main Features

Standard Series

- ODS refrigerant connections
- NPT relief device fitting
- Mounting brackets on all models
- Custom models available upon request

V-Series

- ODS Rotalock Valve connections
- NPT relief device fitting
- Mounting brackets on all models
- Custom models available upon request

Technical Specifications

Maximum working pressure = 450 PSI (31 Bar)

Allowable operating temperature = -20°F to +250°F (-29°C to +121°C)

Henry Technologies' Liquid Refrigerant Receivers are constructed to ASME Section VIII. Additionally, Liquid Receivers are designed and registered for use in Canada. Please contact Technical Support at 1-800-627-5148 for CRN details and list of approved provinces and territories.

Materials of Construction

The shell and caps are made of steel. The ODS connections and Rotalock Valves are made of plated steel. All mounting brackets are made of steel.

Selection Guidelines

Receiver storage capacities are based on the liquid occupying no more than 90% of the internal volume when the temperature of the refrigerant is 90°F (32°C) per ASHRAE Standard 15-78. Receivers should be selected based on the operating charge for all system components, including the liquid lines. It is usual to add a small percentage to cover the refrigerant in long runs of suction and discharge lines, etc. It is essential that the maximum operating charge be determined, e.g., winter charge in air cooled condenser having flooded head pressure control, this being much greater than the normal summer charge.

Installation - Notes

1. Install the Liquid Refrigerant Receiver after the Condenser and before the Liquid Line Filter-Drier.
2. An NPT fitting is provided at the top of the vessel for installation of a pressure relief device. The user must ensure the vessel is protected from over-pressure.

- ❶ Inlet
- ❷ Outlet
- ❸ 1/2" NPT Relief Device Fitting
- ❹ Liquid Level Gauge Mounting Flange
- ❺ Mounting Slot

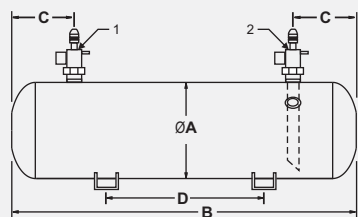

FIG 1

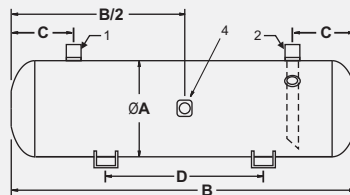
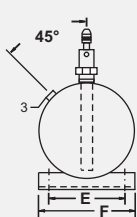
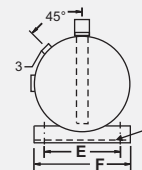

FIG 2



Part No	Fig No	ODS (inch)		Dimensions (inch)						Pump Down Capacity* (lbs)				Internal Volume (ft ³) at 90%	Weight (lbs)
		Inlet	Outlet	ØA	B	C	D	E	F	R134a	R22	R404A	R407C		
S-8640V	1	7/8	7/8	8.63	36.0	4.64	18.00	7.44	9.00	69.7	68.7	59.5	66.8	0.95	65
S-8690V	1	1-1/8	1-1/8	10.75	36.0	6.50	18.00	9.44	11.00	106.9	105.3	91.3	102.4	1.45	115
S-8710V	1	1-1/8	1-1/8	10.75	60.0	6.50	30.00	9.44	11.00	182.8	180.1	156.2	175.1	2.48	166
S-8760V	1	1-3/8	1-3/8	12.75	60.0	8.00	30.56	11.30	13.00	259.5	255.8	221.3	248.7	3.53	218
S-8790	2	2-1/8	1-5/8	14	72.3	8.54	36.00	12.00	16.00	372.4	367	318.2	356.8	5.06	302
S-8810	2	2-5/8	2-1/8	16	60.0	8.88	28.00	14.00	18.00	405.8	400	346.7	388.9	5.52	366
S-8820	2	2-5/8	2-1/8	16	72.0	8.88	36.00	14.00	18.00	491.2	484.2	419.7	470.7	6.68	429
S-8830	2	3-1/8	2-1/8	16	84.0	8.88	42.00	14.00	18.00	576.6	568.3	492.7	552.5	7.84	492
S-8840	2	3-1/8	2-1/8	18	60.0	9.88	30.00	16.00	20.00	504.9	497.6	431.4	483.8	6.86	428
S-8850	2	3-1/8	2-1/8	18	72.0	9.88	36.00	16.00	20.00	612.4	603.5	523.2	586.8	8.32	499
S-8860	2	3-1/8	2-5/8	18	80.0	9.88	40.00	16.00	20.00	684	674.2	584.4	655.5	9.30	552
S-8870	2	3-1/8	2-5/8	20	72.0	10.56	36.00	18.00	22.00	737.1	726.4	629.8	706.3	10.02	555

*All Pump Down Capacities calculated at 90% of receiver volume at 90°F (32°C)

LIQUID REFRIGERANT RECEIVERS

High Pressure, UL

The function of a Liquid Refrigerant Receiver is to store liquid refrigerant to provide continuous flow of liquid refrigerant to the expansion device and to provide storage for the refrigerant charge during system service or maintenance.

Applications

Liquid Refrigerant Receivers are installed in air conditioning and refrigeration systems. The Receiver is installed after the Condenser in order to collect the condensed refrigerant to allow a continuous liquid supply to the expansion device. Liquid Receivers are also used to store the refrigerant charge while the system is pumped down for service or maintenance.

Henry Technologies' Liquid Refrigerant Receivers are suitable for use with HFC, HCFC and CO₂ refrigerants and their associated oils, as well as other industrial fluids non-corrosive to steel and Teflon.

Main Features

- SAE flare inlet connections
- SAE flare Rotalock Valve outlet connection
- Fusible Plug on models Ø3.5" and larger
- Mounting stud or legs on all models
- Custom models available upon request

Technical Specifications

Maximum working pressure = 700 PSI (48.3 Bar)

Allowable operating temperature = 0°F to +250°F (-18°C to +121°C)

Henry Technologies' Liquid Refrigerant Receivers are UL and C-UL Listed by Underwriters Laboratories, Inc. Additionally, Liquid Receivers are designed and registered for use in Canada. Please contact Technical Support at 1-800-627-5148 for CRN details and list of approved provinces and territories.

Materials of Construction

The shell and caps are made of steel. The SAE flare connection, Rotalock Valves, and mounting studs where applicable are made of plated steel. Mounting legs where applicable are made of steel.

Selection Guidelines

Receiver storage capacities are based on the liquid occupying no more than 90% of the internal volume when the temperature of the refrigerant is 90°F (32°C) per ASHRAE Standard 15-78. Receivers should be selected based on the operating charge for all system components, including the liquid lines. It is usual to add a small percentage to cover the refrigerant in long runs of suction and discharge lines, etc. It is essential that the maximum operating charge be determined, e.g., winter charge in air cooled condenser having flooded head pressure control, this being much greater than the normal summer charge.

Installation - Notes

1. Install the Liquid Refrigerant Receiver after the Condenser and before the Liquid Line Filter-Drier.
2. An 1/8 NPT Fusible Plug is included on select models to protect the vessel from over-pressure due to excessive heat. Replace the Fusible Plug immediately if the stamped temperature rating is exceeded.



- ① SAE Flare Inlet
- ② Rotalock Valve SAE Flare Outlet
- ③ 3/8" - 16 Mounting Stud
- ④ Ø 0.38" X 0.63" Mounting Slot

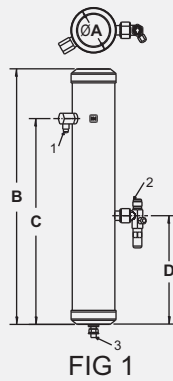

FIG 1

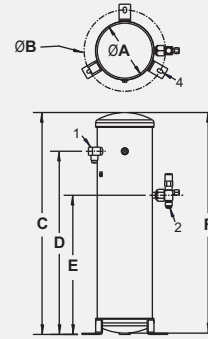

FIG 2

Part No	Fig No	Conn SAE Flare		Dimensions (inch)						Pump Down Capacity* (lbs)		Internal Volume	Weight (lbs)
		Inlet	Outlet	ØA	ØB**	C	D	E	F	R744 (CO ₂)	R410A	(ft ³) at 90%	
SHP-8024	1	1/4	1/4	2.5	N/A	10.00	7.63	7.63	N/A	1.1	1.1	0.017	3.1
SHP-8025	1	1/4	1/4	2.5	N/A	12.00	8.61	7.69	N/A	1.6	1.7	0.026	3.5
SHP-8029	1	1/4	1/4	3.0	N/A	12.00	7.63	7.63	N/A	2.3	2.4	0.038	4.7
SHP-8030	1	1/4	1/4	3.0	N/A	18.00	14.47	7.63	N/A	3.4	3.6	0.057	6.4
SHP-8034	1	1/4	1/4	3.5	N/A	12.00	7.63	7.63	N/A	3.1	3.3	0.052	4.7
SHP-8035	1	1/4	1/4	3.5	N/A	24.00	20.52	7.62	N/A	6.3	6.7	0.104	8.0
SHP-8039	1	1/4	1/4	4.0	N/A	12.00	7.75	7.75	N/A	4.0	4.3	0.067	8.3
SHP-8040	2	1/4	1/4	4.0	6.75	30.40	26.73	8.22	30.00	10.1	10.6	0.167	18.2
SHP-8049	1	1/4	1/4	5.0	N/A	18.00	15.00	15.00	N/A	9.6	10.1	0.159	14.6
SHP-8050	2	1/4	1/4	5.0	7.75	36.38	32.65	8.26	36.00	19.1	20.2	0.317	27.0
SHP-8060	1	3/8	3/8	6.0	N/A	12.00	8.00	8.00	N/A	8.9	9.5	0.148	18.5
SHP-8160	2	3/8	1/2	6.0	8.78	18.14	15.14	15.14	18.00	13.4	14.2	0.223	26.3
SHP-8260	2	1/2	1/2	6.0	8.78	24.14	19.93	15.14	24.00	17.9	18.9	0.297	34.0
SHP-8360	2	5/8	5/8	6.0	8.78	36.14	31.93	15.14	36.00	26.8	28.4	0.445	49.2

*All Pump Down Capacities calculated at 90% of receiver volume at 90°F (32°C)

** (3) Ø 0.38" X 0.63" Mounting slots equally spaced on bolt circle

LIQUID REFRIGERANT RECEIVERS

High Pressure, ASME

The function of a Liquid Refrigerant Receiver is to store liquid refrigerant to provide continuous flow of liquid refrigerant to the expansion device and to provide storage for the refrigerant charge during system service or maintenance.

Applications

Liquid Refrigerant Receivers are installed in air conditioning and refrigeration systems. The Receiver is installed after the Condenser in order to collect the condensed refrigerant to allow a continuous liquid supply to the expansion device. Liquid Receivers are also used to store the refrigerant charge while the system is pumped down for service or maintenance.

Henry Technologies' Liquid Refrigerant Receivers are suitable for use with ammonia, HFC, HCFC and CO₂ refrigerants and their associated oils, as well as other industrial fluids non-corrosive to steel.

Main Features

- ODS refrigerant connections
- NPT relief device fitting
- (3) 1/2 NPT fittings for sight glasses or level switches on 14" diameter and larger
- Mounting legs on all models
- Custom models available upon request

Technical Specifications

Maximum working pressure = 700 PSI (48.3 Bar)

Allowable operating temperature = -20°F to +250°F (-29°C to +121°C)

Henry Technologies' Liquid Refrigerant Receivers are constructed to ASME Section VIII. Additionally, Liquid Receivers are designed and registered for use in Canada. Please contact Technical Support at 1-800-627-5148 for CRN details and list of approved provinces and territories.

Materials of Construction

The shell and caps are made of steel. The ODS connections are made of plated steel and the mounting legs are made of steel.

Selection Guidelines

Receiver storage capacities are based on the liquid occupying no more than 90% of the internal volume when the temperature of the refrigerant is 90°F (32°C) per ASHRAE Standard 15-78. Receivers should be selected based on the operating charge for all system components, including the liquid lines. It is usual to add a small percentage to cover the refrigerant in long runs of suction and discharge lines, etc. It is essential that the maximum operating charge be determined, e.g., winter charge in air cooled condenser having flooded head pressure control, this being much greater than the normal summer charge.

Installation - Notes

1. Install the Liquid Refrigerant Receiver after the Condenser and before the Liquid Line Filter-Drier.
2. An NPT fitting is provided at the top of the vessel for installation of a pressure relief device. The user must ensure the vessel is protected from over-pressure.



CRN

- ❶ ODS Inlet
- ❷ ODS Outlet
- ❸ NPT Relief Device Fitting
- ❹ Ø 0.56" X 0.88" Mounting Slot
- ❺ 1/2" NPT Fitting

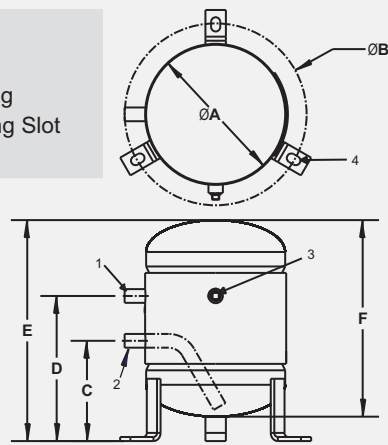

FIG 1

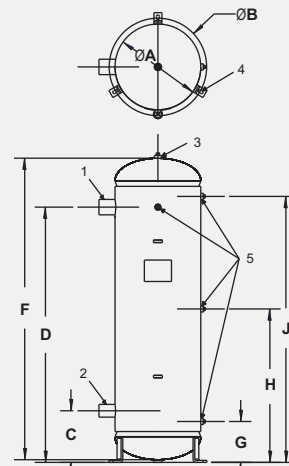

FIG 2

Part No	Fig No	ODS (inch)		NPT Relief	Dimensions (inch)									Weight (lbs)
		Inlet	Outlet		ØA	ØB*	C	D	E	F	G	H	J	
S-8490-HP	1	5/8	5/8	3/8	6.625	9.12	6.23	11.97	16.60	15.00	N/A	N/A	N/A	25.0
S-8500-HP	1	5/8	5/8	3/8	8.625	11.12	6.26	9.00	13.66	12.00	N/A	N/A	N/A	26.0
S-8510-HP	1	5/8	5/8	1/2	8.625	11.12	6.13	12.87	17.50	16.00	N/A	N/A	N/A	34.0
S-8520-HP	1	1-1/8	7/8	1/2	10.75	13.25	6.06	12.93	18.77	18.00	N/A	N/A	N/A	69.0
S-8530-HP	1	1-1/8	1-1/8	1/2	12.75	15.25	7.07	12.06	18.25	18.00	N/A	N/A	N/A	95.0
S-8540-HP	1	1-1/8	1-1/8	1/2	12.75	15.25	6.75	13.75	20.25	20.00	N/A	N/A	N/A	103.0
S-8550-HP	1	1-1/8	1-1/8	1/2	12.75	15.25	6.76	17.75	24.25	24.00	N/A	N/A	N/A	121.0
S-8551-HP	1	1-1/8	1-3/8	1/2	12.75	15.25	7.51	30.51	37.27	36.52	N/A	N/A	N/A	175.0
S-8552-HP	1	1-1/8	1-3/8	1/2	12.75	15.25	6.75	41.76	48.75	48.00	N/A	N/A	N/A	228.0
S-8561-HP	2	1-5/8	1-5/8	3/4	14.0	16.50	9.50	39.50	48.98	47.98	13.50	24.50	35.50	307.00
S-8562-HP	2	2-1/8	1-5/8	3/4	14.0	16.50	9.50	51.50	60.98	59.98	9.50	30.50	51.50	378.0
S-8571-HP	2	2-5/8	2-1/8	3/4	16.0	18.50	9.41	47.41	56.81	55.81	9.41	28.41	47.41	410.0
S-8572-HP	2	2-5/8	2-1/8	3/4	16.0	18.50	9.51	51.51	61.00	60.00	9.51	30.51	51.51	437.0

*(3) Ø 0.56" X 0.88" Mounting slots equally spaced on bolt circle

Part No	Internal Volume (ft³) at 90%	Pump Down Capacity* (lbs)	
		R744(CO₂)	R410A
S-8490-HP	0.21	126.0	13.3
S-8500-HP	0.28	16.8	17.7
S-8510-HP	0.38	23.2	24.5
S-8520-HP	0.64	38.5	40.7
S-8530-HP	0.89	53.8	56.9
S-8540-HP	1.01	60.9	64.4
S-8550-HP	1.24	74.9	79.2
S-8551-HP	1.94	117.0	123.8
S-8552-HP	2.64	159.2	168.5
S-8561-HP	3.10	186.8	197.6
S-8562-HP	3.93	236.8	250.5
S-8571-HP	4.83	291.2	308.0
S-8572-HP	5.20	313.4	331.5

*All Pump Down Capacities calculated at 90% of receiver volume at 90°F (32°C)

RECEIVER ACCESSORIES

LIQUID LEVEL GAUGES FOR RECEIVERS

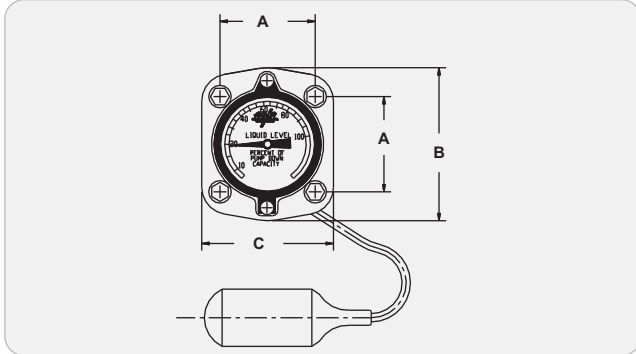

Part No	Receiver Diameter	Dimensions (inch)		
		A	B	C
S-9450	8-5/8	1.77	2.87	2.45
S-9451	10-3/4	1.77	2.87	2.45
S-9452	12-3/4	1.77	2.87	2.45
S-9453	14	1.77	2.87	2.45
S-9454	16	1.77	2.87	2.45
S-9455	18	1.77	2.87	2.45
S-9456	20	1.77	2.87	2.45

Applications

Henry Technologies' Liquid Level Gauges are designed for use on Horizontal Liquid Receivers between 8-5/8" and 20" diameter. Mounting Flanges are not included on most Receivers. Please contact Technical Support at 1-800-627-5148 for application assistance.

Henry Technologies' Liquid Level Gauges are suitable for use with HFC and HCFC refrigerants and their associated oils.

Technical Specifications

Maximum working pressure = 300 PSI (20.7 Bar)

Allowable operating temperature = -20°F to +250°F (-29°C to +121°C)

Installation - Notes

1. Liquid Level Gauges are to be installed horizontally.
2. Full instructions are given in the Product Instruction Sheet, included with each Gauge.

MOUNTING BRACKET ASSEMBLIES

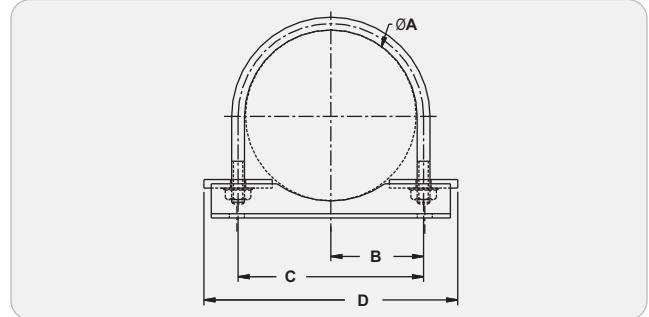

Part No	Dimensions (inch)			
	ØA	B	C	D
3-019-905	5.0	2.72	5.44	7.44
3-019-906	6.0	3.22	6.44	8.44
3-019-908	8-5/8	4.53	9.06	10.18
3-019-910	10-3/4	5.60	11.20	12.33
3-019-912	12-3/4	6.66	13.32	14.45

Applications

Henry Technologies Mounting Brackets are designed for use on vessels between 5" and 12.75" diameter. Mounting hardware for the bracket is not included.

Installation - Notes

1. Mounting brackets are designed for use on horizontal vessels only. Do not use on vertically mounted vessels.

ROTALOCK SPUDS

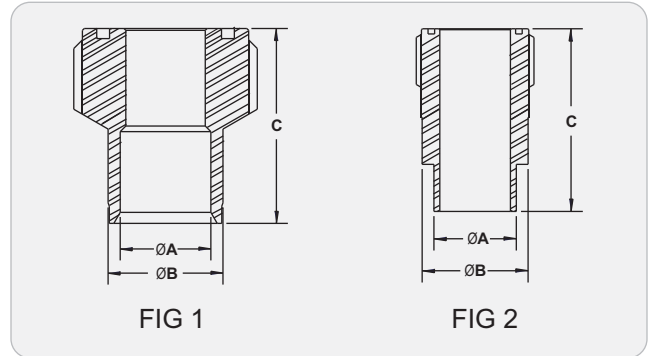

Part No	Fig No	Thread (inch)	Dimensions (inch)		
			ØA	ØB	C
2-009-037	1	1"-14	.497	.625	1.06
3-009-308	2	1-1/4" - 12	.875	1.125	1.94
2-009-046	1	1-3/4" - 12	1.125	1.375	1.72

Applications

Henry Technologies' Rotalock Spuds are available as an accessory for applications where an industry standard Rotalock connection is needed. Rotalock spuds are made of steel and can be welded in or brazed in based on the application. Henry Technologies offers a full line of Rotalock Valves in SAE Flare and ODS connections. See the Rotalock Valve section for details.

Installation - Notes

1. External threads must be protected from spatter on weld in applications.
2. Ensure Rotalock fittings are cool and clean before installing Teflon seal and Rotalock valves.

SUCTION LINE ACCUMULATORS

Horizontal, UL



The function of a Suction Line Accumulator is to provide temporary storage and controlled return of liquid refrigerant and oil to protect the compressor from damage by sudden surges of liquid.

Applications

Suction Line Accumulators are installed in air conditioning and refrigeration systems where sudden return of liquid down the suction line is possible. Suction Line Accumulators are designed to meter both liquid refrigerant and oil back to the compressor at a controlled rate. In addition to protecting the compressor from damage, the Accumulator helps maintain system efficiency and proper crankcase oil levels.

Henry Technologies' Suction Line Accumulators are suitable for use with HFC and HCFC refrigerants and their associated oils, as well as other industrial fluids non-corrosive to steel and copper.

Main Features

- ODS connections
- 3/4 NPT fitting for hot gas bypass or relief device
- 1/2 NPT fitting for liquid injection or relief device
- Mounting brackets included
- Prevents liquid slugging
- Controlled liquid refrigerant and oil return

How it Works

Refrigerant vapor from the evaporator enters the Suction Line Accumulator, along with any liquid refrigerant and oil. The outlet of the Accumulator is placed to ensure vapor is returned to the compressor. On horizontal Accumulators, liquid is metered back to the compressor via a dip tube. This metering only occurs when the compressor is running.

Technical Specifications

Maximum working pressure = 302 PSI (20.8 Bar)

Allowable operating temperature = +15°F to +250°F (-9.5°C to +121°C)

Henry Technologies' Suction Line Accumulators are UL and C-UL Listed by Underwriters Laboratories, Inc. Additionally, Suction Line Accumulators are designed and registered for use in Canada. Please contact Technical Support at 1-800-627-5148 for CRN details and list of approved provinces and territories. Suction Line Accumulators can be CE marked in accordance with PED by adding a "-CE" suffix to the part number. (i.e. S-7621-CE)

Materials of Construction

The shell and caps and mounting brackets are made of steel. The ODS connections are made of plated steel.

Selection Guidelines

Selection of a Suction Line Accumulator should be made based on three capabilities.

1. The Accumulator should have adequate liquid holding capacity. Normally this should not be less than 50% of the total system charge.
2. The Accumulator should be selected in order to avoid excessive pressure drop in the system.
3. The Accumulator should have the capability of returning liquid at the proper rate under a range of load conditions. The listed tonnage ratings ensure sufficient flow for proper liquid refrigerant and oil return.

Installation - Notes

1. Install the Accumulator after the Suction Line Filter-Drier.
2. A pressure relief device connection is provided at the top of the vessel. The user must ensure the vessel is protected from over-pressure.
3. For low temperature applications heat bands should be installed at the outlet end of the horizontal Accumulator.
4. Accumulators may be insulated to prevent condensation or frost on the outside of the shell.
5. Full instructions are given in the Product Instruction Sheet, included with each unit.

- ❶ Inlet
- ❷ Outlet
- ❸ 1/2" NPT Fitting
- ❹ 3/4" NPT Fitting

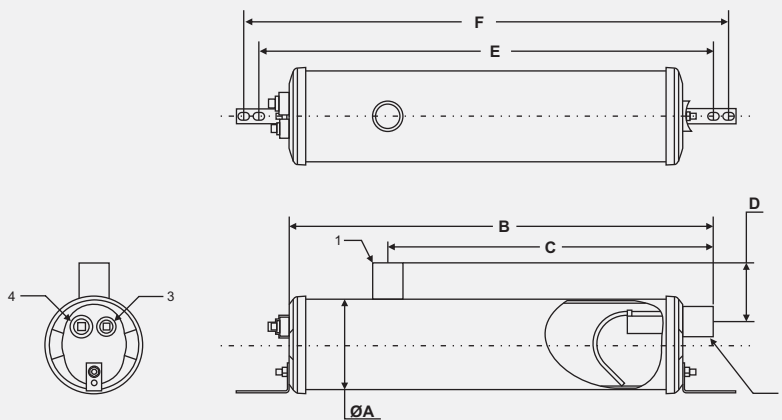

Part No	ODS (inch)	Dimensions (inch)						CE Cat*	Weight (lbs)
		ØA	B	C	D	E	F		
S-7615	1-5/8	6.0	28.00	21.50	3.88	32.00	34.00	CAT II	28.6
S-7621	2-1/8	6.0	34.75	30.25	3.94	38.75	40.75	CAT II	35.3
S-7625	2-5/8	6.0	48.00	43.50	4.13	52.00	54.00	CAT II	46.3

*Optional Cat II CE models available by adding "-CE" suffix to part number. (i.e. S-7621-CE)

Part No	Refrigerant Holding Capacity (lbs at 0°F sat.)			Recommended Tonnage Rating at Suction Evaporating Temperature (°F)								
				R134a			R22			R404A/R507		
	R134a	R22	R404A/R507	+40°	+20°	0°	+40°	+20°	0°	+40°	+20°	0°
S-7615	23.30	21.30	19.30	15.00	10.00	6.25	29.0	20.0	20.0	12.5	19.00	11.50
S-7621	31.60	29.00	26.20	28.60	19.50	12.50	50.0	30.0	30.0	25.0	33.20	22.90
S-7625	46.70	42.60	38.60	50.00	35.00	23.00	95.0	95.0	65.0	45.0	61.70	41.20

SUCTION LINE ACCUMULATORS

Vertical, UL

The function of a Suction Line Accumulator is to provide temporary storage and controlled return of liquid refrigerant and oil to protect the compressor from damage by sudden surges of liquid.

Applications

Suction Line Accumulators are installed in air conditioning and refrigeration systems where sudden return of liquid down the suction line is possible. Suction Line Accumulators are designed to meter both liquid refrigerant and oil back to the compressor at a controlled rate. In addition to protecting the compressor from damage, the Accumulator helps maintain system efficiency and proper crankcase oil levels.

The Heat Exchanger models are designed to be used on low temperature systems to sub-cool the liquid line. Passing the liquid line through the heat exchanger coil on the Accumulator also helps to boil off liquid refrigerant in the Accumulator. Heat Exchanger models can help to improve system efficiency while helping oil flow in the suction line. To avoid overheating the compressor, do not use discharge gas through the heat exchanger coil.

The Heat Pump models are designed to be used on heat pump systems where winter heating can cause an increased amount of liquid refrigerant return. The Heat Pump models incorporate a smaller orifice to prevent excessive liquid flow back to the compressor.

Henry Technologies' Suction Line Accumulators are suitable for use with HFC and HCFC refrigerants and their associated oils, as well as other industrial fluids non-corrosive to steel and copper.

Main Features

- ODS connections
- Heat Exchanger and Heat Pump models available
- 3/8"-16 Mounting stud on all models
- Prevents liquid slugging
- Controlled liquid refrigerant and oil return

How it Works

Refrigerant vapor from the evaporator enters the Suction Line Accumulator, along with any liquid refrigerant and oil. The liquid is held at the bottom of the Accumulator until it is metered back to the compressor. A U-Tube is connected to the outlet of the Accumulator to ensure vapor is returned to the compressor. On Vertical Accumulators, liquid is metered back to the compressor via a screened orifice at the bottom of the U-Tube. This metering only occurs when the compressor is running.

Technical Specifications

Maximum working pressure = 450 PSI (31 Bar)
Allowable operating temperature = +15°F to +250°F (-9.5°C to +121°C)

Henry Technologies' Suction Line Accumulators are UL and C-UL Listed by Underwriters Laboratories, Inc. Additionally, Suction Line Accumulators are designed and registered for use in Canada. Please contact Technical Support at 1-800-627-5148 for CRN details and list of approved provinces and territories. Suction Line Accumulators can be CE marked in accordance with PED by adding a "-CE" suffix to the part number. (i.e. S-7063HE-CE)

Materials of Construction

The shell and caps and U-Tubes are made of steel. The ODS connections and heat exchanger coils are made of solid copper.

Selection Guidelines

Selection of a Suction Line Accumulator should be made based on three capabilities.

1. The Accumulator should have adequate liquid holding capacity. Normally this should not be less than 50% of the total system charge.
2. The Accumulator should be selected in order to avoid excessive pressure drop in the system.
3. The Accumulator should have the capability of returning liquid at the proper rate under a range of load conditions. The listed minimum tonnage ratings ensure sufficient flow for proper liquid refrigerant and oil return.



Installation - Notes

1. Install the Accumulator after the Suction Line Filter-Drier.
2. An integral Fusible Rivet is included to protect the Accumulator from over-pressure due to excessive heat. Replace the Receiver immediately if the stamped temperature rating is exceeded.
3. For low temperature applications heat bands should be installed at the bottom of the Vertical Accumulator.
4. Accumulators may be insulated to prevent condensation or frost on the outside of the shell.
5. Full instructions are given in the Product Instruction Sheet, included with each unit.

- ❶ Inlet
- ❷ Outlet
- ❸ 3/8" -16 Mounting Stud
- ❹ Heat Exchanger Connections

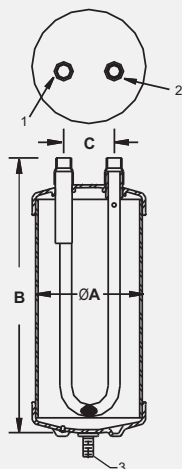

FIG 1

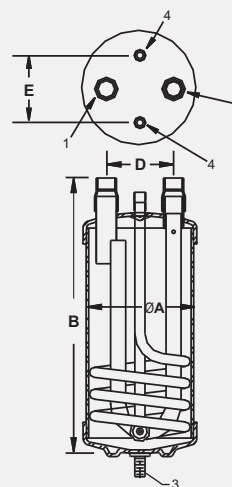

FIG 2

Standard Fig 1	Heat Exchanger Fig 2	Heat Pump Fig 1	Refrigerant ODS (inch)	Heat Exchanger ODS (inch)	Dimensions (inch)					CE Cat*	Weight (lbs)
					ØA	B	C	D	E		
S-7043	N/A	N/A	5/8	N/A	4.0	6.63	1.88	N/A	N/A	SEP	4.4
S-7044	N/A	S-7044HP	1/2	N/A	4.0	10.38	1.88	N/A	N/A	SEP	5.5
S-7045	S-7045HE	S-7045HP	5/8	3/8	4.0	10.38	1.88	3.00	2.50	SEP	5.5
S-7046	S-7046HE	S-7046HP	3/4	3/8	4.0	10.63	1.88	2.50	2.50	SEP	5.5
S-7057	S-7057HE	S-7057HP	7/8	1/2	5.0	13.00	2.25	2.25	2.76	CAT I	15.4
S-7061	S-7061HE	S-7061HP	1-1/8	5/8	6.0	15.00	3.00	3.00	2.88	CAT I	19.8
S-7063S	N/A	N/A	1-3/8	N/A	6.0	20.25	3.00	N/A	N/A	CAT II	24.8
S-7063	S-7063HE	S-7063HP	1-3/8	5/8	6.0	24.75	3.00	3.00	2.88	CAT II	29.8
S-7065	S-7065HE	S-7065HP	1-5/8	3/4	6.0	24.75	3.00	3.00	2.88	CAT II	29.8

*Optional CAT I and II CE model available by adding "-CE" suffix to part number. (i.e. S-7063HE-CE)

Part No	Refrigerant Holding Capacity (lbs at 0°F sat.)			Recommended Tonnage Rating at Suction Evaporating Temperature (°F)															
				R134a					R22					R404A/R507					
				+40°	+20°	0°	-20°	-40°	+40°	+20°	0°	-20°	-40°	+40°	+20°	0°	-20°	-40°	
S-7043	2.3	2.1	1.9	Max	1.4	0.8	0.5	0.3	0.2	1.9	1.3	0.9	0.6	0.4	2.1	1.4	0.9	0.6	0.3
				Min	0.3	0.2	0.1	0.1	0.4	0.4	0.3	0.2	0.1	0.1	0.1	0.5	0.3	0.2	0.1
S-7044	4.4	4.1	3.7	Max	0.7	0.4	0.3	0.2	0.1	1.0	0.7	0.5	0.3	0.2	1.1	0.7	0.5	0.3	0.2
				Min	0.2	0.1	0.1	0.1	0.2	0.2	0.1	0.1	0.1	0.2	0.2	0.1	0.1	0.1	0.3
S-7045	4.4	4.1	3.7	Max	1.4	0.8	0.5	0.3	0.2	1.9	1.3	0.9	0.6	0.4	2.1	1.4	0.9	0.6	0.3
				Min	0.3	0.2	0.1	0.1	0.4	0.4	0.3	0.2	0.1	0.1	0.5	0.3	0.2	0.1	0.1
S-7046	4.4	4.1	3.7	Max	1.9	1.1	0.7	0.4	0.2	2.7	1.8	1.2	0.8	0.5	2.9	1.9	1.2	0.8	0.5
				Min	0.4	0.2	0.2	0.1	0.5	0.6	0.4	0.3	0.2	0.1	0.6	0.4	0.3	0.2	0.1
S-7057	9.2	8.5	7.7	Max	3.2	1.9	1.2	0.7	0.4	4.5	3.1	2.1	1.3	0.8	4.8	3.2	2.1	1.3	0.8
				Min	0.6	0.4	0.2	0.1	0.1	0.9	0.6	0.4	0.3	0.2	0.9	0.6	0.4	0.3	0.2
S-7061	12.7	11.8	10.7	Max	6.6	3.9	2.4	1.4	0.8	9.3	6.5	4.3	2.7	1.7	10.0	6.6	4.3	2.6	1.6
				Min	1.0	0.6	0.4	0.2	0.1	1.5	1.0	0.7	0.4	0.3	1.6	1.0	0.7	0.4	0.2
S-7063S	17.1	15.4	14.0	Max	11.0	6.4	4.0	2.4	1.3	15.4	10.7	7.0	4.5	2.8	16.5	10.9	7.0	4.4	2.6
				Min	2.1	1.2	0.8	0.5	0.3	3.0	2.0	1.4	0.9	0.5	3.2	2.1	1.4	0.9	0.5
S-7063	21.8	20.1	18.2	Max	11.0	6.4	4.0	2.4	1.3	15.4	10.7	7.0	4.5	2.8	16.5	10.9	7.0	4.4	2.6
				Min	2.1	1.2	0.8	0.5	0.3	3.0	2.0	1.4	0.9	0.5	3.2	2.1	1.4	0.9	0.5
S-7065	21.8	20.1	18.2	Max	19.3	11.3	7.0	4.2	2.4	27.2	18.8	12.4	7.9	4.8	29.1	19.1	12.4	7.7	4.6
				Min	3.7	2.1	1.3	0.8	0.5	5.1	3.6	2.4	1.5	0.9	5.5	3.6	2.4	1.5	0.9

SUCTION LINE ACCUMULATORS

Vertical, ASME

The function of a Suction Line Accumulator is to provide temporary storage and controlled return of liquid refrigerant and oil to protect the compressor from damage by sudden surges of liquid.

Applications

Suction Line Accumulators are installed in air conditioning and refrigeration systems where sudden return of liquid down the suction line is possible. Suction Line Accumulators are designed to meter both liquid refrigerant and oil back to the compressor at a controlled rate. In addition to protecting the compressor from damage, the Accumulator helps maintain system efficiency and proper crankcase oil levels.

The Heat Exchanger models are designed to be used on low temperature systems to sub-cool the liquid line. Passing the liquid line through the heat exchanger coil on the Accumulator also helps to boil off liquid refrigerant in the Accumulator. Heat Exchanger models can help to improve system efficiency while helping oil flow in the suction line. To avoid overheating the compressor, do not use discharge gas through the heat exchanger coil.

Henry Technologies' ASME Standard and 1" NPT Suction Line Accumulators are suitable for use with ammonia, HFC and HCFC refrigerants and their associated oils, as well as other industrial fluids non-corrosive to steel. ASME Heat Exchanger Suction Line Accumulators are suitable for use with HFC and HCFC refrigerants and their associated oils, as well as other industrial fluids non-corrosive to steel and copper.

Main Features

- ODS connections
- Heat Exchanger models available
- Mounting Legs on all models
- Models available with 1" NPT fitting for S-9400-1 type level switch
- Prevents liquid slugging
- Controlled liquid refrigerant and oil return

How it Works

Refrigerant vapor from the evaporator enters the Suction Line Accumulator, along with any liquid refrigerant and oil. The liquid is held at the bottom of the Accumulator until it is metered back to the compressor. A tube-in-tube assembly is connected to the outlet of the Accumulator to ensure vapor is returned to the compressor. On Vertical Accumulators, liquid is metered back to the compressor via an orifice at the bottom of the tube-in-tube assembly. This metering only occurs when the compressor is running.

Technical Specifications

Maximum working pressure 8-5/8" to 10-3/4" = 450 PSI (31 Bar)
Maximum working pressure 12-3/4" to 20" = 400 PSI (27.6 Bar)
Allowable operating temperature = -40°F to +250°F (-40°C to +121°C)

Henry Technologies' Suction Line Accumulators are constructed to ASME Section VIII. Additionally, Suction Line Accumulators are designed and registered for use in Canada. Please contact Technical Support at 1-800-627-5148 for CRN details and list of approved provinces and territories. Suction Line Accumulators can be CE marked in accordance with PED by adding a "-CE" suffix to the part number. (i.e. S-7722HE-CE)

Materials of Construction

The shell, caps and all connections are made of steel. The heat exchanger coils are made of solid copper or steel depending on size.

Installation - Notes

1. Install the Accumulator after the Suction Line Filter-Drier.
2. An NPT fitting is provided at the top of the vessel for installation of a Pressure Relief Device. The user must ensure the vessel is protected from over-pressure.
3. For low temperature applications heat bands should be installed at the bottom of the Vertical Accumulator.
4. Accumulators may be insulated to prevent condensation or frost on the outside of the shell.
5. Full instructions are given in the Product Instruction Sheet, included with each unit.



Selection Guidelines

Selection of a Suction Line Accumulator should be made based on three capabilities.

1. The Accumulator should have adequate liquid holding capacity. Normally this should not be less than 50% of the total system charge.
2. The Accumulator should be selected in order to avoid excessive pressure drop in the system.
3. The Accumulator should have the capability of returning liquid at the proper rate under a range of load conditions. The listed minimum tonnage ratings ensure sufficient flow for proper liquid refrigerant and oil return.

- ❶ Inlet
- ❷ Outlet
- ❸ NPT Relief Device Fitting
- ❹ 0.56" X 0.88" Mounting Slot
- ❺ Optional Heat Exchanger Connections
- ❻ 1" NPT Fitting

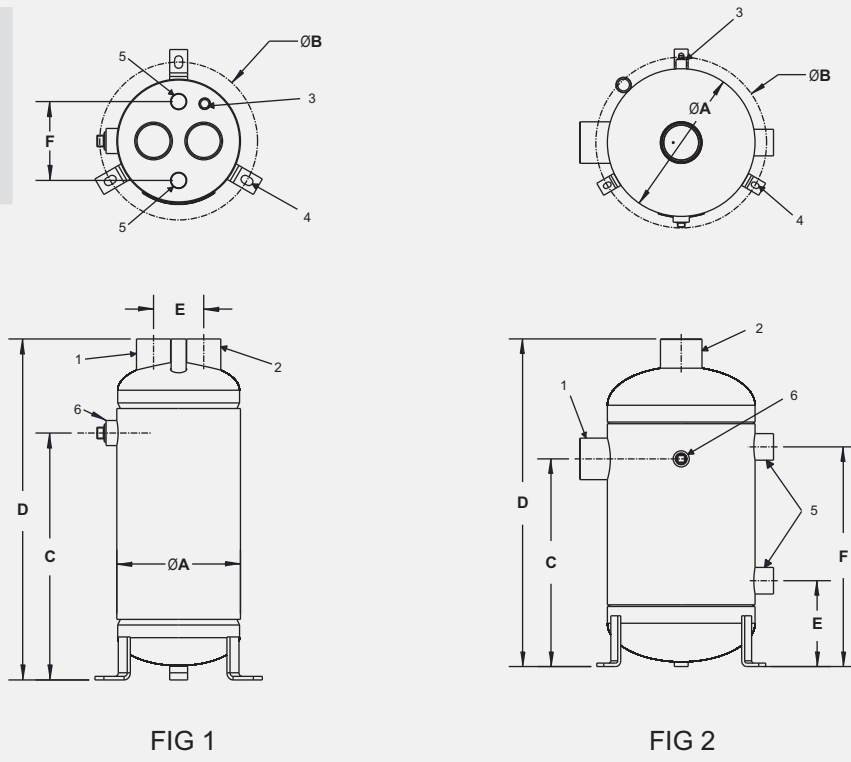

Part No	Heat Exchanger	Fig No	Refrigerant ODS (inch)	Heat Exchanger ODS (inch)	Dimensions (inch)						CE Cat**	Weight (lbs)
					ØA	ØB*	C	D	E	F		
S-7721	S-7721HE	1	2-1/8	7/8	8.63	11.13	N/A	23.79	3.50	5.50	CAT II	59.5
S-7722	S-7722HE	1	2-1/8	7/8	8.63	11.13	17.23	23.79	3.50	5.50	CAT II	64.5
S-7725	S-7725HE	1	2-5/8	1-3/8	10.75	13.25	N/A	23.50	4.63	5.50	CAT II	87.0
S-7726	S-7726HE	1	2-5/8	1-3/8	10.75	13.25	16.00	23.50	4.63	5.50	CAT II	99.0
S-7731	S-7731HE	1	3-1/8	1-3/8	12.75	15.25	N/A	26.00	5.50	5.88	CAT III	114.6
S-7732	S-7732HE	1	3-1/8	1-3/8	12.75	15.25	17.25	26.00	5.50	5.88	CAT III	144.6
S-7741	S-7741HE	2	4-1/8	2-5/8	16.00	18.50	22.50	35.50	9.30	23.80	CAT III	224.9
S-7742	N/A	2	4-1/8	N/A	20.00	18.00	30.50	44.50	N/A	N/A	CAT IV	286.6

*(3) Ø 0.56" X 0.88" Mounting slots equally spaced on bolt circle. S-7742 uses (4) 0.64" holes equally spaced on bolt circle
 **Optional CAT II, III and IV CE models available by adding "-CE" suffix to part number i.e. (S-7722HE-CE)

Part No	Refrigerant Holding Capacity (lbs at 0°F sat.)			Recommended Tonnage Rating at Suction Evaporating Temperature (°F)															
				R134a					R22					R404A/R507					
	R134a	R22	R404A/R507	+40°	+20°	0°	-20°	-40°	+40°	+20°	0°	-20°	-40°	+40°	+20°	0°	-20°	-40°	
S-7721	32.5	27	27	Max	43.0	25.1	15.6	9.3	5.2	60.4	41.8	27.6	17.7	10.8	64.7	42.5	27.6	17.1	10.1
				Min	7.7	4.5	2.8	1.7	0.9	10.9	7.5	5.0	3.2	1.9	11.7	7.7	5.0	3.1	1.8
S-7725	48.5	40	40	Max	64.0	37.4	23.2	13.8	7.8	90.0	62.2	41.1	26.3	16.1	96.5	63.4	41.1	25.5	15.1
				Min	12.8	7.5	4.6	2.8	1.6	17.9	12.4	8.2	5.3	3.2	19.2	12.6	8.2	5.1	3.0
S-7731	80	66	66	Max	95.0	55.5	34.5	20.5	11.6	133.5	92.4	60.9	39.1	23.8	143.1	94.0	61.0	37.8	22.4
				Min	19.1	11.1	6.9	4.1	2.3	26.8	18.6	12.2	7.9	4.8	28.8	18.9	12.3	7.6	4.5
S-7741	136	135	122	Max	149.4	87.2	54.2	32.2	18.2	209.9	145.2	95.8	61.4	37.5	225.1	147.9	95.9	59.4	35.3
				Min	48.2	28.1	17.5	10.4	5.9	67.7	46.9	30.9	19.8	12.1	72.6	47.7	31.0	19.2	11.4
S-7742	297	277	251	Max	149.4	87.2	54.2	32.2	18.2	209.9	145.2	95.8	61.4	37.5	225.1	147.9	95.9	59.4	35.3
				Min	48.2	28.1	17.5	10.4	5.9	67.7	46.9	30.9	19.8	12.1	72.6	47.7	31.0	19.2	11.4

SUCTION LINE ACCUMULATORS

Vertical, Industrial

The function of a Suction Line Accumulator is to provide temporary storage and controlled return of liquid refrigerant and oil to protect the compressor from damage by sudden surges of liquid.

Applications

Suction Line Accumulators are installed in air conditioning and refrigeration systems where sudden return of liquid down the suction line is possible. Suction Line Accumulators are designed to meter both liquid refrigerant and oil back to the compressor at a controlled rate. In addition to protecting the compressor from damage, the Accumulator helps maintain system efficiency and proper crankcase oil levels.

Henry Technologies' AF-Series Suction Line Accumulators are suitable for use with ammonia, HFC and HCFC refrigerants and their associated oils, as well as other industrial fluids non-corrosive to steel.

Main Features

- ODS connections
- Heat Exchanger models available
- Mounting legs on all models
- Models available with 1" NPT fitting for S-9400-1 type level switch
- Prevents liquid slugging
- Controlled liquid refrigerant and oil return

How it Works

Refrigerant vapor from the evaporator enters the Suction Line Accumulator, along with any liquid refrigerant and oil. The liquid is held at the bottom of the Accumulator until it is metered back to the compressor. A tube-in-tube assembly is connected to the outlet of the Accumulator to ensure vapor is returned to the compressor.

Oil return is assured from the Accumulator through the tube-in-tube assembly at full gas flow conditions. The use of compressor suction un-loaders will reduce the gas CFM flow rate and the oil return rate will be affected if maintained for a long period. Hot gas bypass for capacity reduction will maintain constant CFM. The tube-in-tube assembly may not be required under conditions where oil rich refrigerant can be drained from the bottom of the accumulator through a needle valve, sight glass and solenoid valve (cycle with the compressor). The needle valve should be set to flash off the refrigerant and the oil bled by gravity into the suction line.

A Boil-Out is recommended under low temperature conditions and is essential for all hot gas defrost systems. The liquid line should be routed through the boil-out coil to provide a steady heat source to evaporate off liquid trapped in the accumulator. The liquid should be evaporated before commencement of the next defrost cycle.

Technical Specifications

Maximum working pressure 6-5/8" to 20" = 400 PSI (27.6 Bar)

Maximum working pressure 24" = 300 PSI (20.7 Bar)

Allowable operating temperature = -40°F to +250°F (-40°C to +121°C)

Henry Technologies' Suction Line Accumulators are constructed to ASME Section VIII. Additionally, Suction Line Accumulators are designed and registered for use in Canada. Please contact Technical Support at 1-800-627-5148 for CRN details and list of approved provinces and territories.

Materials of Construction

The shell and caps are made of steel. All connections including the boil-out are made of steel.

Installation - Notes

1. Install the Accumulator after the Suction Line Filter-Drier.
2. An NPT fitting is provided at the top of the vessel for installation of a Pressure Relief Device. The user must ensure the vessel is protected from over-pressure.
3. Accumulators may be insulated to prevent condensation or frost on the outside of the shell.



Selection Guidelines

Selection of a Suction Line Accumulator should be made based on three capabilities.

1. The Accumulator should have adequate liquid holding capacity. Normally this should not be less than 50% of the total system charge.
2. The Accumulator should be selected within the maximum CFM rating provided in order to avoid excessive pressure drop in the system.

- ❶ Inlet
- ❷ Outlet
- ❸ NPT Relief Device Fitting
- ❹ Boil-Out Connections
- ❺ 1" NPT Drain

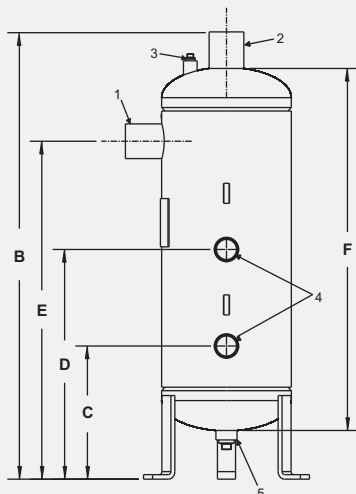
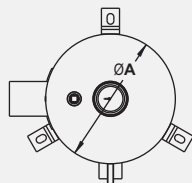

Part No	ODS (inch)		Max CFM	Refrigerant Holding Capacity* (lbs)			Dimensions (inch)					Weight (lbs)	
	Inlet/Outlet	Boil-Out		R12	R22	R502	ØA	B	C	D	E		F
AF-06018	2-1/8	1-1/8	40	15	15	16	6.63	25.50	9.25	17.25	17.25	18.0	32
AF-06024	2-1/8	1-1/8	40	24	24	25	6.63	31.50	9.25	17.25	23.25	24.0	41
AF-06030	2-1/8	1-1/8	40	33	33	34	6.63	37.50	9.25	17.25	29.25	30.0	50
AF-08024	2-5/8	1-1/8	70	37	37	38	8.63	28.50	9.10	17.10	22.96	24.0	57
AF-08030	2-5/8	1-1/8	70	51	51	53	8.63	37.00	9.09	17.09	28.96	30.0	69
AF-08036	2-5/8	1-1/8	70	66	66	69	8.63	43.00	9.09	17.09	34.96	36.0	81
AF-08042	2-5/8	1-1/8	70	81	81	85	8.63	49.00	9.09	17.09	40.96	42.0	91
AF-10030	2-5/8	1-5/8	110	77	77	80	10.75	34.03	11.04	19.04	28.00	30.0	100
AF-10036	2-5/8	1-5/8	110	101	101	105	10.75	42.97	10.97	18.97	33.94	36.0	117
AF-10042	2-5/8	1-5/8	110	124	124	129	10.75	49.21	11.10	19.10	40.08	42.0	135
AF-10048	2-5/8	1-5/8	110	145	145	150	10.75	52.01	11.00	19.00	45.90	48.0	152
AF-12030	3-1/8	1-5/8	155	100	99	104	12.75	36.88	11.38	19.38	25.89	30.0	132
AF-12036	3-1/8	1-5/8	155	133	132	138	12.75	42.88	11.38	19.38	31.89	36.0	155
AF-12042	3-1/8	1-5/8	155	166	165	172	12.75	48.88	11.38	19.38	37.89	42.0	178
AF-12048	3-1/8	1-5/8	155	198	197	206	12.75	52.13	11.38	19.38	48.89	48.0	200
AF-14042 +	4-1/8	2-1/8	195	177	176	184	14.0	48.76	12.75	22.75	42.00	42.0	273
AF-14048 +	4-1/8	2-1/8	195	216	215	225	14.0	54.75	12.75	22.75	41.69	48.0	311
AF-14054 +	4-1/8	2-1/8	195	256	254	266	14.0	60.75	12.75	22.75	47.69	54.0	346
AF-14060 +	4-1/8	2-1/8	195	299	296	310	14.0	66.62	12.75	22.75	53.55	60.0	384
AF-16042 +	5	2-1/8	255	195	194	207	16.0	53.71	14.77	24.77	37.77	42.0	325
AF-16048 +	5	2-1/8	255	256	253	265	16.0	59.71	14.77	24.77	43.77	48.0	365
AF-16060 +	5	2-1/8	255	352	350	371	16.0	71.71	14.77	24.77	55.77	60.0	448
AF-16072 +	5	2-1/8	255	460	457	485	16.0	83.71	14.77	24.77	67.77	72.0	535
AF-20048 +	5	2-5/8	405	335	332	350	20.0	58.44	14.00	24.00	41.00	48.0	472
AF-20060 +	5	2-5/8	405	528	525	549	20.0	70.44	14.00	24.00	53.00	60.0	572
AF-20072 +	5	2-5/8	405	680	676	707	20.0	81.39	13.44	23.44	64.45	72.0	672
AF-20084 +	5	2-5/8	405	775	770	806	20.0	94.44	14.00	24.00	77.00	84.0	772
AF-24048 +	6	2-5/8	590	530	526	550	24.0	56.88	15.88	25.88	39.38	48.0	600
AF-24060 +	6	2-5/8	590	720	715	750	24.0	68.88	15.88	25.88	51.38	60.0	712
AF-24072 +	6	2-5/8	590	919	913	955	24.0	80.89	15.88	25.88	63.38	72.0	836
AF-24084 +	6	2-5/8	590	1159	1152	1205	24.0	92.89	15.88	25.88	75.38	84.0	960

*Refrigerant holding capacity is the weight of refrigerant the suction accumulator can safely hold without the risk of carry-over into the compressor suction line

+Custom Built (Non-Stock Item)

SUCTION LINE ACCUMULATORS

SA Series, Vertical, UL

The main purpose of a Suction Line Accumulator is to prevent a sudden surge of liquid refrigerant or oil from returning down the suction line and into a compressor. The suction line accumulator is a temporary reservoir for liquid refrigerant and oil.

The accumulator is designed to meter both the liquid refrigerant and oil back to the compressor at a controlled rate. This prevents compressor damage. By metering the liquid refrigerant and oil back to the compressor, the accumulator also helps maintain system efficiency and proper crankcase oil levels.

Applications

Suction Line Accumulators are installed in air conditioning and refrigeration systems where a sudden return of liquid down the suction line is possible. Henry Technologies' SA Series Suction Line Accumulators are suitable for use with HFC and HCFC refrigerants and their associated oils, as well as other industrial fluids non-corrosive to steel and copper.

Main Features

- ODS connections
- Prevents liquid slugging
- Controlled liquid return and oil return
- Large flow capacity
- Low pressure drop
- Screen protected orifice
- Solid copper connections
- Powder-coated finish
- Cost effective

How it Works

Refrigerant vapor from the evaporator enters the Suction Line Accumulator, along with any liquid refrigerant and oil. The liquid is held at the bottom of the Accumulator until it is metered back to the compressor. A U-Tube is connected to the outlet of the Accumulator to ensure vapor is returned to the compressor. On Vertical Accumulators, liquid is metered back to the compressor via a screened orifice at the bottom of the U-Tube. This metering only occurs when the compressor is running.

Technical Specifications

Maximum working pressure = 450 PSI (31 Bar)
Allowable operating temperature = -22°F to +122°F (-30°C to +50°C)

Henry Technologies' Suction Line Accumulators are UL and C-UL Listed by Underwriters Laboratories, Inc.

Materials of Construction

The shell and end caps are made from carbon steel. Branch connections are made from copper.



Part No	ODS (inch)	Dimensions (inch)				CE Cat*	Weight (lbs)
		ØA	B	C	D		
SA-7044	1/2	4.00	6.42	5.43	2.50	SEP	4.41
SA-7045S	5/8	4.00	6.58	5.43	2.50	SEP	4.41
SA-7045	5/8	4.00	10.95	9.80	2.50	Cat I	6.39
SA-7046	3/4	4.00	11.06	9.80	2.50	Cat I	6.39
SA-7056	3/4	5.00	9.92	8.74	2.76	Cat I	7.94
SA-7057S	7/8	5.00	10.08	8.74	2.76	Cat I	7.94
SA-7057	7/8	5.00	14.88	13.54	2.76	Cat I	11.24
SA-7051	1 1/8	5.00	18.74	17.24	2.76	Cat I	13.89
SA-7053	1 3/8	5.00	18.86	17.24	2.95	Cat I	13.89
SA-7065	1 5/8	6.00	26.69	24.92	2.95	Cat II	28.66

- ☒ Inlet
- ② Outlet
- Ž M10 stud & nut
- ④ Relief connections, 1/4 FPT

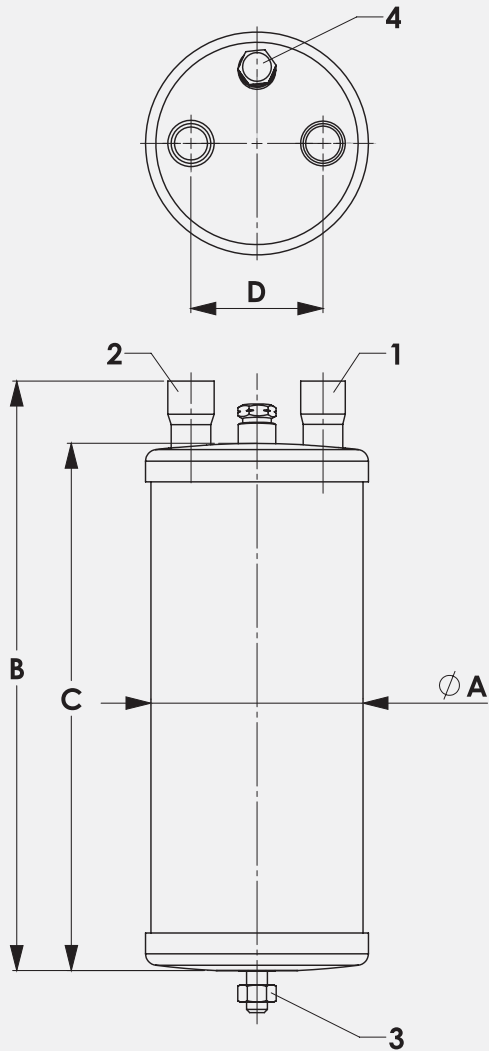

Selection Guidelines

Selection of a Suction Line Accumulator should be made based on three capabilities.

1. The Accumulator should have adequate liquid holding capacity. Normally this should not be less than 50% of the total system charge.
2. The Accumulator should be selected in order to avoid excessive pressure drop in the system.
3. The Accumulator should have the capability of returning liquid at the proper rate under a range of load conditions. The listed minimum tonnage ratings ensure sufficient flow for proper liquid refrigerant and oil return.

Additional Selection Information

Two accumulators can be piped in series to increase holding capacity. Oil will be metered from one accumulator to the next to ensure proper oil flow to the compressors. Adding a second identical accumulator will effectively double the holding capacity of a single accumulator.

Piping two identical accumulators in parallel will double the tonnage capacity. Two identical accumulators must be used.

On low temperature systems (0°F and below) a heater band should be installed to help boil off the liquid refrigerant and aid oil flow. Do not add too much heat or there is a risk of overheating the compressors.

Installation - Notes

1. Install the Accumulator after the Suction Line Filter-Drier.
2. An integral Fusible Rivet is included to protect the Accumulator from over-pressure due to excessive heat. Replace the Receiver immediately if the stamped temperature rating is exceeded.
3. For low temperature applications heat bands should be installed at the bottom of the Vertical Accumulator.
4. Accumulators may be insulated to prevent condensation or frost on the outside of the shell.
5. Full instructions are given in the Product Instruction Sheet, included with each unit.

Part No	Refrigerant Holding Capacity (lbs at 0°F sat).			Recommended Tonnage Rating at Suction Evaporating Temperature (°F)															
				R134a					R22					R404A/R507					
	R134a	R22	R404A/R507	+40°	+20°	0°	-20°	-40°	+40°	+20°	0°	-20°	-40°	+40°	+20°	0°	-20°	-40°	
SA-7044	2.2	2.2	2.0	Max	0.7	0.4	0.3	0.2	0.2	1.0	0.7	0.5	0.3	0.2	1.1	0.7	0.5	0.3	0.2
				Min	0.2	0.1	0.1	0.1	0.1	0.2	0.1	0.1	0.1	0.1	0.1	0.2	0.2	0.1	0.1
SA-7045S	2.2	2.2	2.0	Max	1.4	0.8	0.5	0.3	0.2	1.9	1.3	0.9	0.6	0.4	2.1	1.4	0.9	0.6	0.3
				Min	0.3	0.2	0.1	0.1	0.1	0.4	0.3	0.2	0.1	0.1	0.5	0.3	0.2	0.1	0.1
SA-7045	4.6	4.6	4.2	Max	1.4	0.8	0.5	0.3	0.2	1.9	1.3	0.9	0.6	0.4	2.1	1.4	0.9	0.6	0.3
				Min	0.3	0.2	0.1	0.1	0.1	0.4	0.3	0.2	0.1	0.1	0.5	0.3	0.2	0.1	0.1
SA-7046	4.6	4.6	4.2	Max	1.9	1.1	0.7	0.4	0.2	2.7	1.8	1.2	0.8	0.5	2.9	1.9	1.2	0.8	0.5
				Min	0.4	0.2	0.2	0.1	0.1	0.6	0.4	0.3	0.2	0.1	0.6	0.4	0.3	0.2	0.1
SA-7056	6.2	6.1	5.5	Max	1.3	0.9	0.6	0.4	0.2	4.1	2.8	1.8	1.1	0.7	2.5	1.7	1.1	0.7	0.4
				Min	0.3	0.2	0.2	0.1	0.1	0.9	0.6	0.4	0.3	0.1	0.4	0.3	0.2	0.2	0.2
SA-7057S	6.0	5.9	5.3	Max	3.2	1.9	1.2	0.7	0.4	4.5	3.1	2.1	1.3	0.8	4.8	3.2	2.1	1.3	0.8
				Min	0.6	0.4	0.2	0.1	0.1	0.9	0.6	0.4	0.3	0.2	0.9	0.6	0.4	0.3	0.2
SA-7057	10.1	10.0	9.0	Max	3.2	1.9	1.2	0.7	0.4	4.5	3.1	2.1	1.3	0.8	4.8	3.2	2.1	1.3	0.8
				Min	0.6	0.4	0.2	0.1	0.1	0.9	0.6	0.4	0.3	0.2	0.9	0.6	0.4	0.3	0.2
SA-7051	13.5	13.3	11.9	Max	4.6	3.2	2.1	1.4	0.8	14.2	9.5	6.3	3.9	2.3	8.9	6.2	3.8	2.4	1.5
				Min	0.6	0.5	0.4	0.3	0.3	2.1	1.4	0.9	0.6	0.3	0.8	0.7	0.6	0.5	0.3
SA-7053	13.5	13.3	11.9	Max	7.9	5.4	3.4	2.2	1.3	23.4	15.7	10.4	6.5	3.8	15.3	10.2	6.2	3.9	2.4
				Min	1.3	1.1	0.9	0.7	0.6	4.5	3.0	2.0	1.3	0.7	1.7	1.4	1.1	0.9	0.7
SA-7065	28.9	28.4	25.4	Max	19.3	11.3	7.0	4.2	2.4	27.2	18.8	12.4	7.9	4.8	29.1	19.1	12.4	7.7	4.6
				Min	3.7	2.1	1.3	0.8	0.5	5.1	3.6	2.4	1.5	0.9	5.5	3.6	2.4	1.5	0.9

NOTES

NOTES

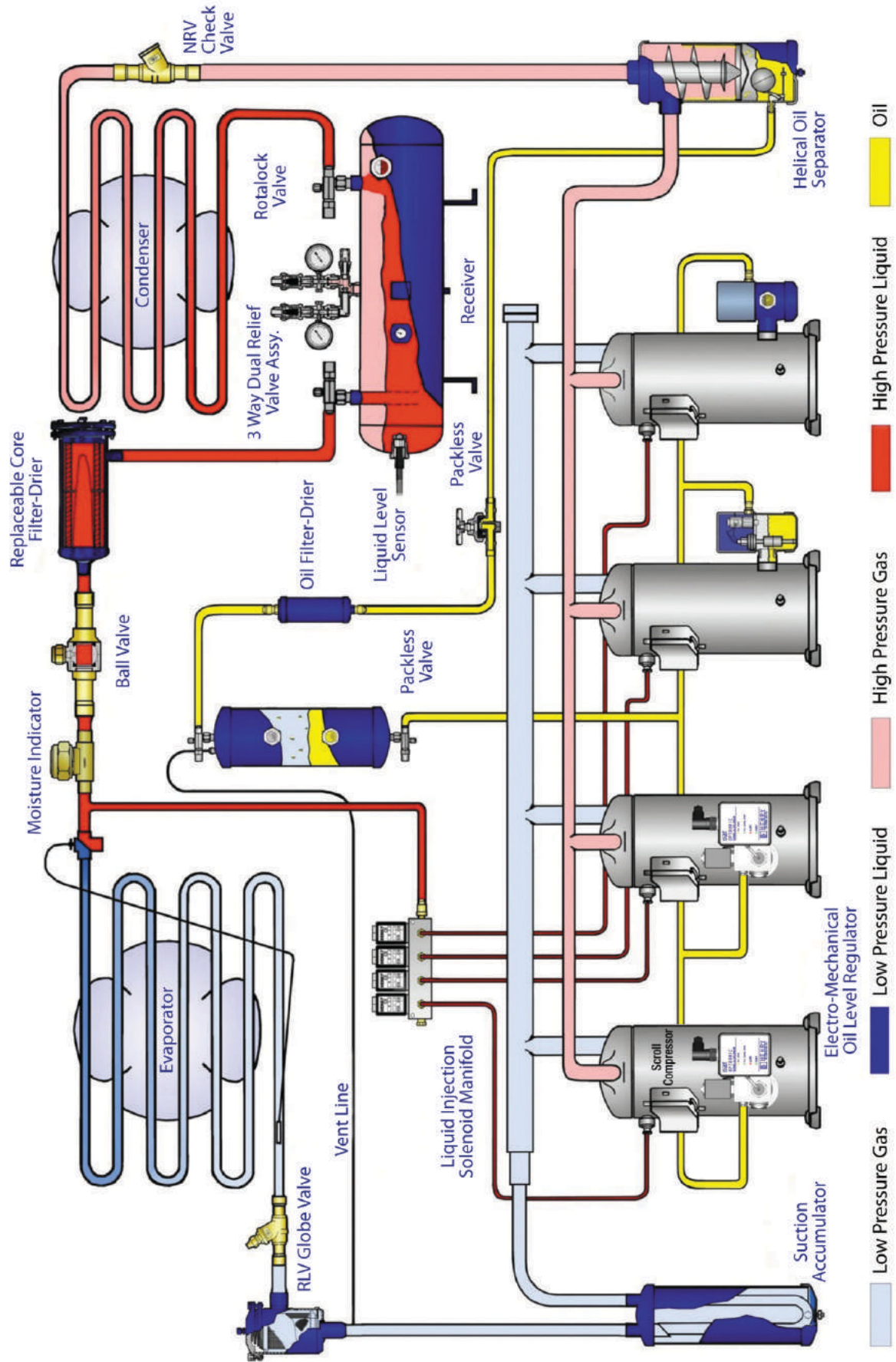



HENRY

T E C H N O L O G I E S

COMMERCIAL REFRIGERATION DIVISIONS

HENRY TECHNOLOGIES, INC

701 S. Main Street, Chatham, IL 62629

USA

Tel. +1 (217) 483-2406 • Toll Free +1 (800) 96-HENRY • Fax +1 (217) 483-2408

www.henrytech.com

HENRY TECHNOLOGIES, LTD.

76 Mossland Road
Glasgow G52 4XZ
SCOTLAND, UK
+44 141 882 4621

www.henrytech.co.uk

HENRY TECHNOLOGIES

AUSTRALIA PTY. LTD.

25 Tullamarine Park Road
Tullamarine 3043 VICTORIA, AU
+61 3 9286 4222

www.henrytech.com.au

HENRY TECHNOLOGIES, PTE LTD.

Blk 203B Henderson Road
12-11 Henderson Industrial Park 159546
SINGAPORE
+65 6 295 0055

www.henrytech.com

PROCESS PLANT EQUIPMENT DIVISION

Brantford Plant

36 Craig Street
Brantford, Ontario N3T 5T6

CANADA

+1 (800) 263-0086

www.ht-industrial.com

Stafford Plant

13125 Royal Drive
Stafford, TX 77477

USA

+1 (281) 499-0909

www.ht-industrial.com