



HENRY
TECHNOLOGIES

Product Catalogue



DESIGNED FOR PERFORMANCE



henrytech.co.uk

HENRY

The information contained in this catalogue is correct at the time of publication.

Henry Technologies has a policy of continuous product development; we therefore reserve the right to change technical specifications without prior notice.

Extensive changes within our industry have seen products of Henry Technologies being used in a variety of new applications. We have a policy, where possible, to offer research and development assistance to our clients. We readily submit our products for assessment at the development stage, to enable our clients to ascertain product suitability for a given design application.

It remains the responsibility of the system designer to ensure all products used in the system are suitable for the application.

For details of our warranty cover, please refer to our standard terms and conditions of sale. Copies are available on request.

Date of publication:- June 2013



P R O D U C T C A T A L O G U E • E 2

Introduction	04
The Brands	05
Manufacturing and quality	06
Engineering	07

CONTENTS

AC&R COMPONENTS PRODUCTS

Oil management systems	08
Helical oil separators	10
Helical oil separator-reservoirs	16
Conventional oil separators	19
Transcritical CO ₂ oil management controls	22
Mechanical oil level regulators	25
Optronic oil level regulator	28
Electro-mechanical oil level regulators	30
Oil reservoirs	32
Reservoir pressure valves	34
Oil regulator shut-off valves	35
Oil strainers	36
Oil filters and oil filter driers	37
Liquid level switches	39
Valve manifolds	41
Suction line accumulators	42
Discharge line mufflers	46
Vibration eliminators	48
Sight glasses	51
Sealed filter driers	52
Replaceable core filter driers	56
Replacement components	61
Accessories	63

HENRY PRODUCTS

Ball valves & ball valves with sight glass (bvsg)	64
Check valves	67
Magni-chek valves	69
Globe valves	70
Packless valves	71
Packed shut off valves	75
High pressure packed shut-off valve	79
Positive oil exchange valve	80
Pressure relief valves	81
Pressure relief valves x series	83
Pressure relief valves transcritical CO ₂	85
Rupture discs	87
Three-way shut off valves	89
Pressure Indicator	90
Sentry safety device assembly	91
Safety device kits	93
Y strainer	94
Moisture indicators	95
Replacement components	96

INTRODUCTION

Located in Glasgow, Scotland, Henry Technologies Ltd manufactures and distributes a wide range of products for commercial and industrial refrigeration applications throughout Europe, the Middle East, Africa and Asia. Founded in 1914, the Company builds on almost a century of experience to ensure that our customers receive components that are delivered on time, perform to specification and are reliable in service.

Henry Technologies Ltd is a subsidiary of Henry Technologies Inc based in Beloit, Wisconsin, USA. Under the ownership of Hendricks Holdings since 2005, the group focus is to continually improve our customers experience in every aspect of service.

The Henry Technologies group continues to grow by strategic and vendor partnerships that uphold our standards of quality, technical leadership, service and value for money. These values have long been associated with our brands: AC&R Components and Henry. The AC&R Components brand is a world leader for quality, design and innovation of oil management controls and other compressor protective devices. The Henry brand is associated with flow products such as ball valves, check valves and pressure relief valves for the commercial and industrial refrigeration and air conditioning industries.



THE BRANDS



AC&R Components Inc. was acquired by The Henry Valve Company in 1970. Today both products ranges are manufactured in production facilities in Chatham, Illinois, USA and Glasgow, Scotland with some products also produced in our plants in China and Australia.

The AC&R Components brand is a world leader for quality, design and innovation of oil management controls and other compressor protective devices. Products include:

- Oil Separators
- Mechanical, Electro-Mechanical and Electronic Oil Level Regulators
- Suction Line Accumulators
- Mufflers
- Sight Glasses
- Filter Driers
- Vibration Eliminators



The Henry Valve Company, commenced production in Chicago in 1914. Today, Henry Technologies is a leading manufacturer of flow control products for the commercial refrigeration and air-conditioning industries. Products include:

- Ball Valves
- Check Valves
- Globe Valves
- Pressure Relief Valves
- Safety Device Assemblies

HENRY



MANUFACTURING & QUALITY

MANUFACTURING

The majority of products are manufactured in our plant in Scotland. Henry Technologies has its own machining, fabrication, assembly and finishing facilities. The range is augmented by products from Henry facilities in Australia, the USA, Canada and China. Manufacturing is supported by a sophisticated local infrastructure of precision engineering suppliers.

The manufacturing philosophy in Scotland follows lean principles. Henry Technologies has embarked on a journey of waste elimination. The Company exploits the skills and experience of employees to develop new and better ways to deliver value to our customers. We see this as an unfinished task but we are proud of our achievements and welcome customer visits where ideas may be shared.

QUALITY

AC&R Components and Henry are brands that speak of quality. A systematic approach to design, material selection, sourcing, manufacture and testing has ensured that our products have an enviable reputation as the benchmark in our market. Management systems comply with various international standards including ISO9001:2008, the Pressure Equipment Directive and individual national standards.

Henry Technologies is committed to business excellence. We continually review our processes in order to identify potential areas for improvement. In this way, we continue to promote and improve quality. Employees are trained to ensure a good understanding of roles and responsibilities and customer feedback is used to highlight opportunities to refine our designs and procedures.

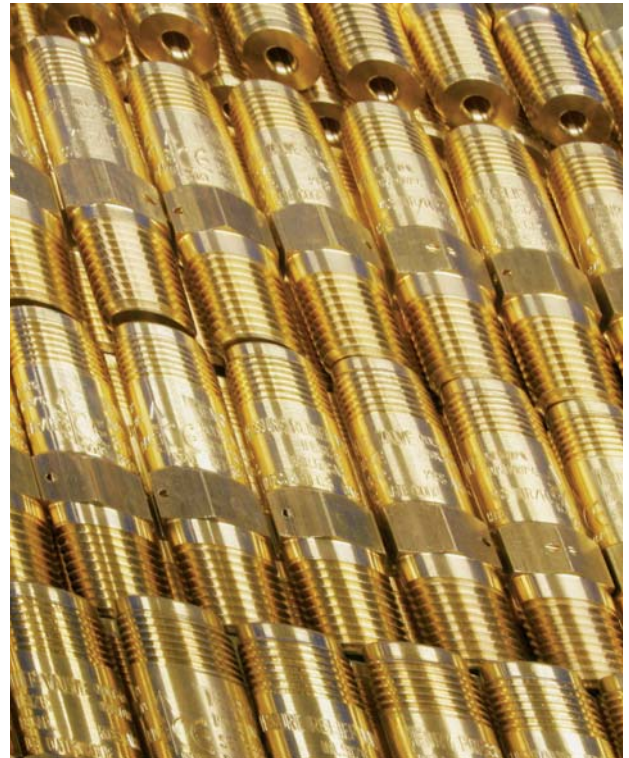

Bureau Veritas UK Limited Notified Body 0041

CERTIFICATE OF QUALITY SYSTEM APPROVAL
N° CE-0041-PED-D-HEN-001-13-GBR

BUREAU VERITAS UK Limited, acting within the scope of its notification (notified body number 0041), attests that the quality system operated by the manufacturer for production, final inspection and testing of the pressure equipment identified below has been examined against the provisions of module D, as specified in the Pressure equipment Regulations 1999 (EC Pressure Equipment Directive n° 97/23/EC), and found to satisfy the provisions of the directive which apply to it.

Manufacturer (name): **Henry Technologies Ltd**

Address: **Mossland Rd, Hillington Industrial Estate, Glasgow, G52 4XZ, UNITED KINGDOM**

Trading name: **As Above**

Equipment description: **Pressure Equipment for Refrigeration Systems**

Identification of equipment concerned (list attached when necessary): **Safety Relief Valves & Helical Oil Separators/Reservoirs per the BIB1 Certificates listed below**

Number(s) of the EC type-examination or EC design-examination certificate(s) concerned by the approval: **As listed on the Annex of this certificate**

This certificate is valid until (MM/DD/YYYY): **10/12/2015**

The approval is conditional upon the surveillance audits, tests and verifications to be carried out by Bureau Veritas, as per the provisions stated in the agreement signed by both the manufacturer and Bureau Veritas.

This certificate shall be deemed to be void and the manufacturer shall alone bear any consequences pursuant to its use, where the manufacturer fails to comply with its undertakings as per the agreement in respect of (a) implementation of the approved quality system, (b) conformity of the equipment with the EC type-approval or design-approval conditions and (c) inspection and tests on the final product, and generally where the manufacturer fails in particular to comply with any of its obligations under directive n° 97/23/EC of 29 May 1997 as transposed in the applicable law(s).

Made at	On (MM/DD/YYYY)	Approved and Recorded in	Signed by
Manchester	02/26/2013	UK	Peter Hammons

Code d'enregistrement / Registration code: 2013/0017_A89PLUK

This certificate is subject to the terms of Bureau Veritas General Conditions of Service attached to the agreement signed by the applicant.

© Bureau Veritas UK Limited PV 105 rev 01 Contract No : 7221326
1/2 Annexe D <http://www.bureauveritas.com/ped>

Certificate of Registration

QUALITY MANAGEMENT SYSTEM - ISO 9001:2008

This is to certify that:

Henry Technologies Limited
Mossland Road
Hillington Park
Glasgow
G52 4XZ
United Kingdom

Hold Certificate No: **FM 10696**
and operates a Quality Management System which complies with the requirements of ISO 9001:2008 for the following scope:

The design and manufacture of finished metal products bearing the AC&R Components label, including oil separators, discharge line mufflers, suction line accumulators, oil reservoir and oil level regulators, liquid receivers, manufactured in steel.
The manufacture of valves for refrigeration and air conditioning applications and for hot gas applications to customer specifications including ball valves, globe and check valves, diaphragm packless valves, pressure relief valves manufactured in forged brass, bronze alloy or cast iron.

For and on behalf of BSI:

Gary Fenlon, Global Assurance Director

Originally registered: **01/09/1990** Latest Issue: **07/09/2012** Expiry Date: **21/10/2015**

Page: 1 of 1

This certificate was issued electronically and remains the property of BSI and is bound by the conditions of contract. An electronic certificate can be authenticated [online](http://www.bsigroup.com/ClientDirectory). Printed copies can be validated at www.bsigroup.com/ClientDirectory

Information and Contact: BSI, Kitemark Court, Davy Avenue, Knowlhill, Milton Keynes MK9 8PP. Tel: +44 845 080 9000
BSI Assurance UK Limited, registered in England under number 7805321 at 389 Chiswick High Road, London W4 4AL, UK
A Member of the BSI Group of Companies.

ENGINEERING

ENGINEERING

Henry Technologies Ltd has its own engineering team. These engineers are responsible for providing technical support to both our in-house manufacturing team and our customers. In addition, they are responsible for new product development. A systematic design approach is taken to ensure each new product meets or exceeds customer requirements. Our design process focuses on delivering both innovative and robust new products.

The latest design tools are employed including 3D modelling, Finite Element Analysis (FEA) and Computational Fluid Dynamics (CFD). Each new design is rigorously tested before product release.

GENERAL INFORMATION

To ensure reliability, all products are leak tested in line with in-house manufacturing and quality procedures. Functional testing is also conducted where appropriate.

A powder coat paint system is applied as an external finish to all tank products. This paint system provides excellent corrosion protection, passing the 500 hour ASTM B117 salt spray test.

This catalogue lists standard products for use with conventional refrigerants. If you have a requirement for customised products, please contact Customer Services. Henry Technologies is able to design and manufacture a range of customised products for special applications.

Products are supplied with imperial (inch) connections as standard. A range of metric sizes (mm) is also available. For details please contact Customer Services.

Technical notes

- All dimensions stated in catalogue are nominal. All product dimensions are subject to manufacturing tolerances.
- Catalogue line drawings only show main dimensions and features. If additional information is required, please contact the factory. 3D solid models and 2D drawings are available on request.
- Abbreviations:-
 - MWP = Maximum working pressure (allowable). This is the same as the Product Design Pressure.
 - NPT = American National Standard Taper Pipe Thread.
 - SAE = Straight threaded connection, in accordance with SAE J513-92; ASME B1.1-89.
 - ODS = Female soldering connection. This size is equal to the outside diameter of the mating pipe.
 - Kv = Valve constant. The rate of water flow, m³/hr, for a differential pressure ΔP of 1 barg, at the rated full opening.
- All weights listed in the catalogue are net dry weights.

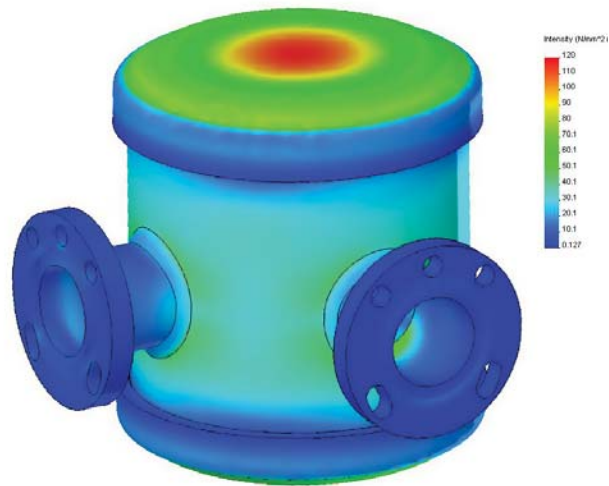

FEA - OIL LEVEL REGULATOR



CFD - PRESSURE RELIEF VALVE

OIL MANAGEMENT SYSTEMS

This guide is intended for oil management systems installed with scroll or reciprocating compressors using HCFC or HFC refrigerants. For other systems, please contact Henry Technologies for guidance.

A proper oil management system is essential to ensure compressor lubrication and energy efficient cooling.

An oil management system is a cost effective alternative to replacing expensive compressors due to incorrect lubrication. If selected and installed correctly, an oil management system will give years of trouble free operation, protecting the compressors from both low and excess oil levels, with little or no maintenance. Excessive oil within the system can lead to a slug of oil returning to the compressor. A slug of oil can be as damaging to a compressor as a slug of liquid refrigerant.

By removing oil from the discharge gas, the system efficiency is increased. Oil in a refrigeration or air conditioning system reduces the efficiency of the system by:-

1. A reduction in heat transfer due to oil coating of the condenser and evaporator walls.
2. Displacing refrigerant volume resulting in an increase in system mass flow.

Oil does not change phase from liquid to gas and is therefore a very poor refrigerant. A minimal amount of oil flowing through the system is necessary to provide lubrication to valves, but a very small amount is needed.

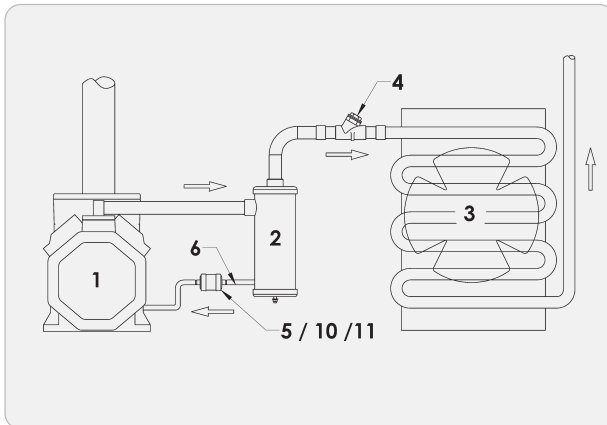

SINGLE COMPRESSOR SYSTEM

Single Compressor System

A single compressor has the most basic oil system. The compressor discharge is piped to the inlet of an oil separator (2) and the outlet of the oil separator is piped to the condenser (3). A discharge check valve should be fitted (4). An oil return line (6) is connected from the oil separator through an oil strainer (5), oil filter (10) or oil filter drier (11), to the compressor crankcase.

A float valve in the oil separator opens and feeds a small amount of oil by-passing the rest of the cooling system. The oil is returned under discharge pressure to the crankcase. The float valve prevents hot gas from bypassing to the crankcase by closing when the oil level falls.

It is recognised best practice to fit a solenoid valve, sight glass, and shut-off valve in the oil return line. These components are not shown in the diagram.

Refer to equipment list for further details on each component in the oil system

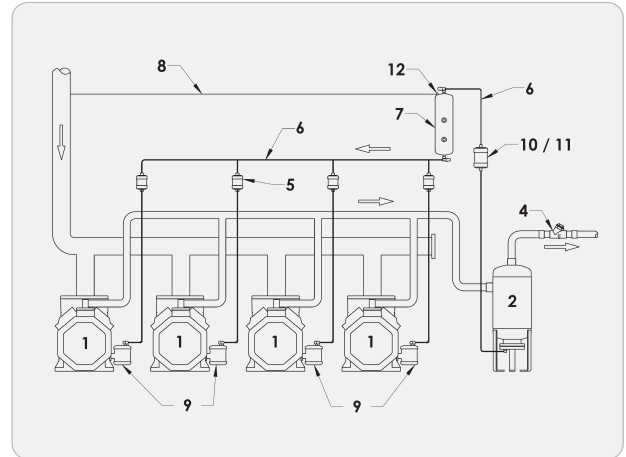

LOW PRESSURE OIL MANAGEMENT SYSTEM

Low Pressure Oil Management System

This system is normally used for parallel compressors and uses three main components; Oil Separator (2), Oil Reservoir (7) and Oil Level Regulators (9). The common discharge is piped to the inlet of the oil separator and the outlet of the oil separator is piped to the condenser via a discharge check valve (4). An oil return line is connected from the oil separator to the top valve of the oil reservoir (7). A vent line (8) is installed to the suction line, using a pressure valve (12), to reduce the pressure in the reservoir. This makes a low pressure system. The pressure valve will maintain the reservoir at a set pressure above suction. Although mechanical oil level regulators (9) are shown in the diagram, Electro-mechanical and Optronic oil level regulators can also be used.

The bottom valve of the oil reservoir is piped to the oil level regulators mounted on the compressor crankcases. These regulators open to feed oil as the oil level drops and close as the oil level rises to the set level. In this way, the oil level in each compressor is controlled. An oil strainer (5) per regulator should be used to remove debris from the oil. One oil strainer is installed between the oil reservoir and each regulator. Alternatively, the oil strainers may be replaced by one oil filter (10) or an oil filter drier (11). The oil filter or oil filter drier must however be installed between the separator and oil reservoir. Due to the scavenging nature of POE oil, it is recommended to install either an oil filter or oil filter drier on a HFC/POE system instead of individual oil strainers.

On dual temperature and satellite systems, ensure that all regulators see positive oil differential pressures within their allowable operating range.

It is recognised best practice to fit a solenoid valve, sight glass, and shut-off valve in the oil return line. These components are not shown in the diagram.

Refer to equipment list for further details on each component in the oil system

High Pressure Oil Management System

High pressure oil systems remove the need for a separate oil reservoir. This type of system also reduces the amount of pipework and fittings.

A high pressure oil system relies on the oil level regulators being able to operate with a high pressure differential. Mechanical oil level regulators should not be used on this type of system. The Optronic oil level regulator is recommended for this application. Electro-mechanical regulators can also be used, depending on the model. A high pressure system is not recommended for HCFC/mineral oil systems due to potential foaming problems.

A discharge check valve should be fitted (4). An oil separator-reservoir (13) is fitted in the discharge line similar to an oil separator. The oil return connection, positioned at the bottom of the vessel, is piped to the oil level regulators. An oil filter (10) or oil filter drier (11) should be installed between the oil separator-reservoir and the regulators (14).

It is recognised best practice to fit a solenoid valve, sight glass, and shut-off valve in the oil return line. These components are not shown in the diagram.

Refer to equipment list for further details on each component in the oil system

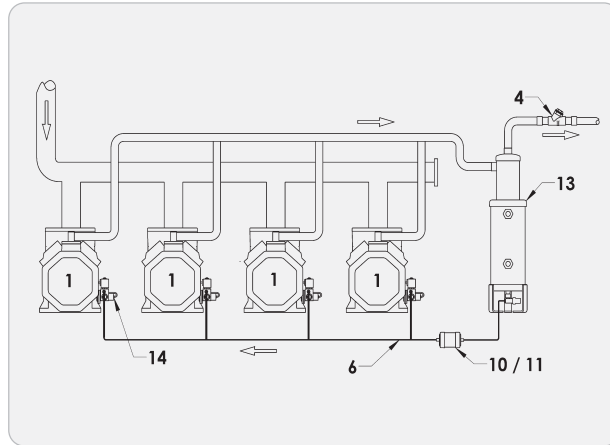

HIGH PRESSURE OIL MANAGEMENT SYSTEM

EQUIPMENT LIST FOR OIL LEVEL CONTROL

1. **Compressor.**
2. **Oil Separator** – The function of an Oil Separator is to remove oil from the discharge gas and return it to the compressor, either directly or indirectly. This helps maintain the compressor crankcase oil level and raises the efficiency of the system by preventing excessive oil circulation. Oil separators are not 100% efficient, so installing an oil separator should not be viewed as a replacement for oil traps, accumulators, or good oil return piping practices. Henry Technologies manufacture two different types of oil separator, Helical and Conventional.
3. **Condenser.**
4. **Discharge Check Valve** – The function of a Check Valve is to allow fluid flow in one direction only. This prevents condensed liquid refrigerant returning down the discharge line into the separator. If this check valve is not installed the separator can feed excessive liquid refrigerant to the compressor on start up. This can cause oil dilution, excessive foaming, erratic oil pressures and possible compressor damage. The check valve must be installed after the oil separator.
5. **Oil Strainer** – The function of an Oil Strainer is to remove system debris from the refrigerant oil. Their purpose is to protect compressors and oil level regulators from damage. For recommendations on HFC/POE systems, refer to section on oil filters and oil filter driers.
6. **Oil Return Line.**
7. **Oil Reservoir** – The function of an Oil Reservoir is to provide a holding charge of oil, as part of a Low Pressure Oil Management System. The amount of oil circulating in a system varies depending on the operating conditions. The oil reservoir caters for these fluctuations by providing additional storage capacity.
8. **Vent Line.**
9. **Mechanical Oil Level Regulators** – The function of a Mechanical Oil Level Regulator is to control the oil level in the compressor crankcase. This protects the compressors from damage. There are two main types of oil level regulators, fixed level and adjustable level. The fixed level regulators have an allowable oil pressure differential range of 0.35 to 2.1 barg. The adjustable level regulators have an allowable oil pressure differential range of 0.35 to 6.2 barg. Oil pressure differential is the difference between the crankcase pressure and the pressure in the oil reservoir. Gravity pressure head should be included also, if applicable. Some regulator models are fitted with an equalisation connection that enables the oil levels between several compressors to be balanced.
10. **Oil Filter** – The function of an Oil Filter is to remove system debris from the refrigerant oil. An oil filter is recommended for HFC/POE systems instead of individual oil strainers, where filtration only is required.
11. **Oil Filter Drier** – The function of an Oil Filter Drier is to remove both system debris and moisture from the refrigerant oil. An oil filter drier is recommended for HFC/POE systems instead of individual oil strainers, where both filtration and moisture removal is required.
12. **Pressure Vent Valve** – The function of a Pressure Vent Valve is to maintain a positive pressure in the Oil Reservoir above the compressor crankcase pressure. Three different pressure settings are available; 0.35 barg, 1.4 barg and 2.4 barg. A higher pressure differential will increase the oil flow rate from the oil reservoir back to the compressors. The pressure setting should be selected taking into account the allowable oil pressure differential of the oil level regulator type.
13. **Oil Separator-Reservoir** – The function of an Oil Separator-Reservoir is to provide a Separator and Oil Reservoir in one unit. It is designed for high pressure systems and eliminates the need for a separate Oil Reservoir and its associated piping.
14. **Optronic Oil Regulator** – The function of the Optronic Regulator is to control the oil level in the compressor crankcase. This protects the compressors from damage. This regulator can be used on high pressure systems.

HELICAL OIL SEPARATORS

The function of a Helical Oil Separator is to efficiently remove oil from the discharge gas and return it to the compressor, either directly or indirectly. This helps maintain the compressor crankcase oil level and raises the efficiency of the system by preventing excessive oil circulation.

A higher level of efficiency is to be expected compared to a conventional type oil separator.

Applications

Helical oil separators can be used in a wide variety of applications. Common applications include multi-compressor racks and remote condensing units.

Helical oil separators are intended for Low Pressure Oil Management Systems. These products are designed for use with scroll and reciprocating type compressors. They are not recommended for screw or rotary vane compressors.

The standard product range is designed for use with HCFC and HFC refrigerants, along with their associated oils. The SN range is suitable for use with HCFC, HFC and ammonia refrigerants. The SH high-pressure range is intended for R410A and sub-critical CO₂ applications.

Please contact Henry Technologies for new or special applications.

How it works

Upon separator entry, refrigerant gas containing oil in aerosol form encounters the leading edge of the helical flighting. The gas/oil mixture is centrifugally forced along the spiral path of the helix causing heavier oil particles to spin to the perimeter, where impingement with a screen layer occurs. The screen layer functions as both an oil stripping and draining medium. Separated oil flows downward along the boundary of the shell through a baffle and into an oil collection chamber at the bottom of the separator.

The specially engineered baffle isolates the oil chamber and eliminates oil re-entrainment by preventing turbulence. The virtually oil free refrigerant gas then exits through a second screen fitting just below the lower edge of the helical flighting. A float activated oil return needle valve allows the separated oil to return to the compressor crankcase or oil reservoir. There is a permanent magnet positioned at the bottom of the oil collection chamber to capture any system metal debris, which could impair the operation of the needle valve. With proper selection, an oil separation efficiency of up to 99% can be achieved.

Main Features

- Patented Henry Technologies Design[#]
- High oil separation efficiency - up to 99%
- Low pressure drop
- No blocked elements because of too much oil in the system
- No oil blow-out at start up from oil left in a coalescing element
- Cleanable/replaceable oil float assemblies for S-52*, SN52* and S-54* models

[#] US Patents 5113671, 5404730 & 5271245; Mexico 173552; Denmark, France, UK & Italy 0487959; Germany P69106849.6-08; Taiwan UM-74863; & other worldwide patents pending

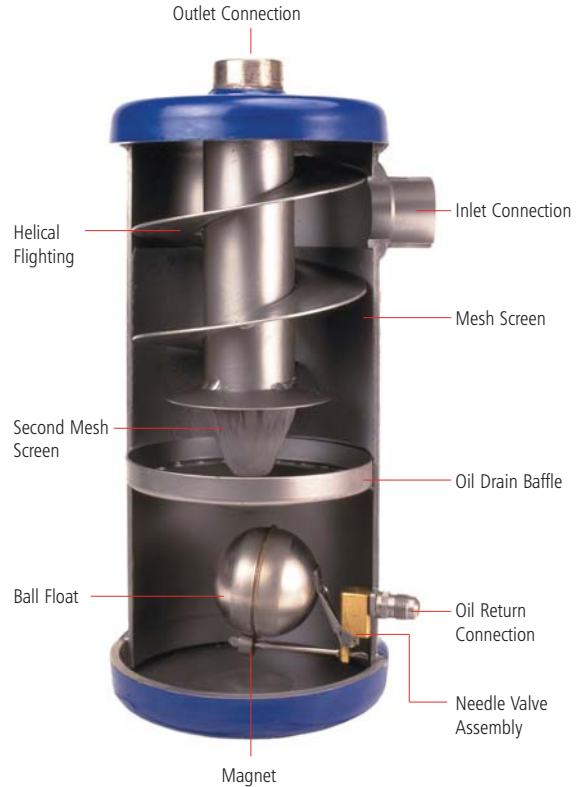

Technical Specification

For all models excluding SH series:-

Allowable operating pressure = 0 to 31 barg

Allowable operating temperature = -10°C to +130°C

For SH models:-

Allowable operating pressure = 0 to 45 barg

Allowable operating temperature = -10°C to +110°C

Materials of Construction

The main components; shell, end caps and connections are made from carbon steel. The oil float is made from stainless steel. The needle valve seat is made from either brass or steel, dependent on model.

STANDARD RANGE													
Part No	Conn Size (inch)	Dimensions (mm)							Mounting details	Drawing reference	Weight (kg)	Pre-charge qty (l)	CE Cat
		Ø A	B	C	D	E	F	Ø G					
S-5180	1/4 ODS	64	166	45	43	N/A	19.5	N/A	M10	fig.1	1.5	0.1	SEP
S-5181	3/8 ODS	64	195	45	71	N/A	19.5	N/A	M10	fig.1	1.5	0.1	SEP
S-5182-CE	1/2 ODS	102	333	69	64	N/A	58.5	N/A	M10	fig.2	4	0.4	Cat I
S-5185-CE	5/8 ODS	102	384	69	66	N/A	58.5	N/A	M10	fig.2	4	0.4	Cat I
S-5187-CE	7/8 ODS	102	434	74	76	N/A	58.5	N/A	M10	fig.2	4	0.4	Cat I
S-5188-CE	1 1/8 ODS	102	483	75	78	N/A	58.5	N/A	M10	fig.2	4	0.4	Cat I
S-5190-CE	1 3/8 ODS	152	384	108	91	N/A	60.5	N/A	M10	fig.2	9	1.1	Cat I
S-5192-CE	1 5/8 ODS	152	428	108	98	N/A	60.5	N/A	M10	fig.2	9	1.1	Cat I
S-5194-CE	2 1/8 ODS	152	436	114	105	N/A	60.5	N/A	M10	fig.2	9	1.1	Cat I
S-5285-CE	5/8 ODS	102	516	69	66	95	N/A	120.7	2 x Ø11mm holes	fig.3	7	0.7	Cat I
S-5287-CE	7/8 ODS	102	563	74	76	95	N/A	120.7	2 x Ø11mm holes	fig.3	7	0.7	Cat I
S-5288-CE	1 1/8 ODS	102	614	75	78	95	N/A	120.7	2 x Ø11mm holes	fig.3	7	0.7	Cat I
SN-5290-CE	1 3/8 ODS	152	508	108	91	99	N/A	113	2 x Ø14mm slots	fig.3	12.5	0.7	Cat I (see note 1)
SN-5292-CE	1 5/8 ODS	152	559	108	98	99	N/A	113	2 x Ø14mm slots	fig.3	13	0.7	Cat I (see note 1)
SN-5294-CE	2 1/8 ODS	152	559	114	105	99	N/A	113	2 x Ø14mm slots	fig.3	13	0.7	Cat I (see note 1)
S-5411-CE	1 5/8 ODS	219	650	148	164	100	N/A	166	3 x Ø14mm slots	fig.4	26	0.7	Cat II
S-5412-CE	2 1/8 ODS	219	650	148	164	100	N/A	166	3 x Ø14mm slots	fig.4	26	0.7	Cat II
S-5413-CE	2 5/8 ODS	273	758	183	201	125	N/A	223	3 x Ø14mm slots	fig.4	40	0.7	Cat II
S-5414-CE	3 1/8 ODS	324	831	215	229	100	N/A	273	3 x Ø14mm slots	fig.4	56	0.7	Cat IV

Notes:-
1. For use with ammonia, the CE Category increases to II

HIGH PRESSURE RANGE													
Part No	Conn Size (inch)	Dimensions (mm)							Mounting details	Drawing reference	Weight (kg)	Pre-charge qty (l)	CE Cat
		Ø A	B	C	D	E	F	Ø G					
SH-5182-CE	1/2 ODS	102	352	69	81	N/A	61	N/A	M10	fig.2	4	0.4	Cat I
SH-5185-CE	5/8 ODS	102	401	69	81	N/A	61	N/A	M10	fig.2	4	0.4	Cat I
SH-5187-CE	7/8 ODS	102	453	74	94	N/A	61	N/A	M10	fig.2	4.5	0.4	Cat I
SH-5188-CE	1 1/8 ODS	102	500	75	93	N/A	61	N/A	M10	fig.2	4.5	0.4	Cat I
SH-5190-CE	1 3/8 ODS	152	570	108	135	95	N/A	100	3 x Ø14mm slots	fig.5	9.5	1.1	Cat II
SH-5192-CE	1 5/8 ODS	152	615	108	140	95	N/A	100	3 x Ø14mm slots	fig.5	10.1	1.1	Cat II
SH-5194-CE	2 1/8 ODS	152	623	115	145	95	N/A	100	3 x Ø14mm slots	fig.5	10.3	1.1	Cat II

Adding the suffix "M" to the part number denotes that metric connections are preferred e.g. S-5192M-CE. The suffix "X" denotes that a 10mm ODS oil return is preferred instead of the standard 3/8 flare e.g. S-5185X-CE. Adding the suffix "XM" denotes the separator is to be fitted with both variations. Please contact Henry Technologies for availability of M, X and XM versions.

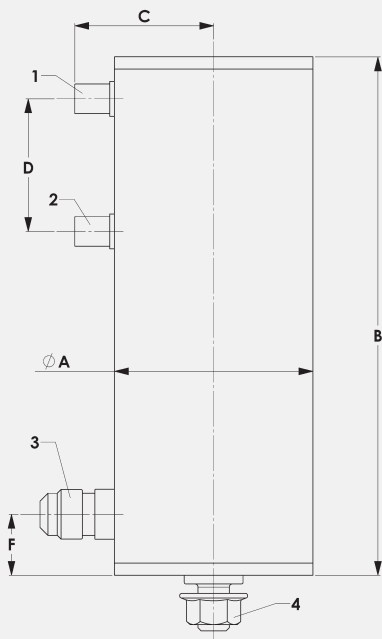

Fig. 1

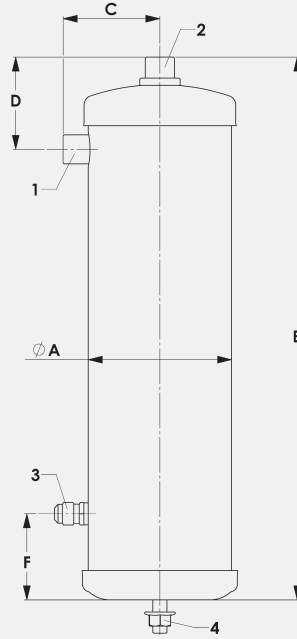

Fig. 2

- 1 Inlet
- 2 Outlet
- 3 Oil return, 3/8 SAE Flare
- 4 M10 stud and nut

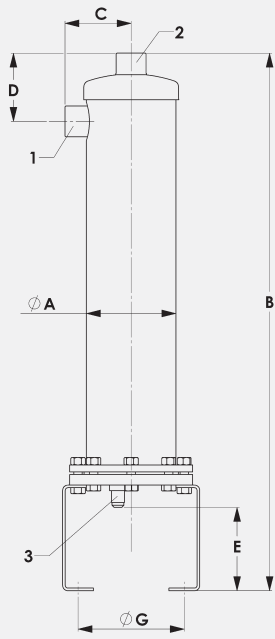

Fig. 3

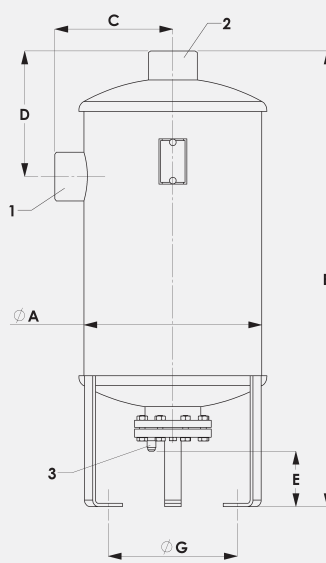

Fig. 4

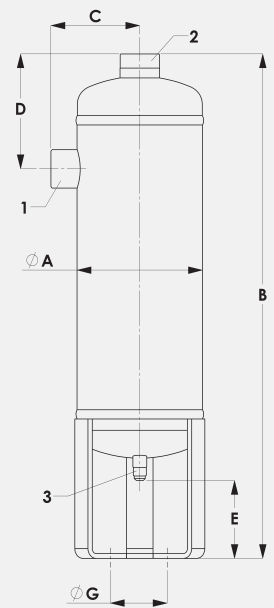

Fig. 5

Performance data

This table provides a summary of the kW capacity of each separator for fixed evaporating and condensing temperatures. This table can be used as a quick reference guide. However, the Selection Guidelines are recommended for helical separator sizing.

Selection Guidelines

The most important parameter for selection is the discharge volumetric flow rate, expressed in m³/hr. This is the calculated volume flow rate at entry to the oil separator. It is not to be confused with the compressor displacement or swept volume.

A quick method is to use the selection graphs. These graphs have been compiled for the common refrigerants R404A/R507, R134a and R407F.

Graphs for other refrigerants are available on request.

The graphs are based on a simplified refrigeration cycle and hence the corresponding calculation of discharge volume flow rate is approximate. Although approximate, this method of selection has been used successfully for many years for standard refrigeration systems.

Where a higher degree of accuracy is required to calculate the m³/hr, the flow rate calculation method is recommended. The flow rate calculation method is also recommended for CO₂ cascade and special applications.

HELICAL OIL SEPARATORS							
Part No	Capacity in kW of refrigeration at nominal evaporator temperature						Maximum discharge volume (m ³ /hr)
	R404A/507		R134a		R407F		
	-40°C	5°C	-40°C	5°C	-40°C	5°C	
S-5180	2.6	3.5	1.8	2.6	3.4	4	1.3
S-5181	3.5	5.3	2.6	3.5	4.5	5.2	1.7
S-5182-CE, SH-5182-CE	5.3	7	3.5	5.3	6.8	8	2.6
S-5185-CE, S-5285-CE & SH-5185-CE	14.1	19.4	10.6	14.1	17.8	20.8	6.8
S-5187-CE, S-5287-CE, & SH-5187-CE	23	30	15.8	19.4	26.7	31.3	10.2
S-5188-CE, S-5288-CE & SH-5188-CE	29.8	38.7	21.1	26.4	35.6	41.7	13.6
S-5190-CE, SN-5290-CE & SH-5190-CE	42.2	52.8	28.2	35.2	49	57.3	18.7
S-5192-CE & SN-5292-CE	52.8	66.9	38.7	45.8	62.4	72.9	23.8
S-5194-CE, SN-5294-CE & S-5411-CE	84.4	109	63.4	73.8	98	115	37.4
S-5412-CE	109	144	77.4	95	129	151	49.3
S-5413-CE	225	292	162	197	267	312	102
S-5414-CE	352	461	253	310	419	490	159.8

Notes:-
1. All data is for a 38°C condensing temperature, 18°C suction temperature and on connection size being the same as the compressor discharge valve

Helical Separator Selection using the Graphs

To use the selection graphs, the refrigerant type, maximum refrigeration capacity, minimum refrigeration capacity, evaporating temperature and the condensing temperature is required.

Example

Refrigerant R404A
 Maximum refrigeration capacity = 40 kW
 Minimum refrigeration capacity = 25 kW
 Evaporating temperature = -35°C
 Condensing temperature = +40°C

From the R404A graph, follow the -35°C evaporator temperature line to the intersection of the 40°C condensing temperature line. Extend a line horizontally from this point to the m³/hr/kW factor. Multiply this factor by the maximum and minimum refrigeration capacities to compute the maximum and minimum discharge volume flow rates.

From the R404A graph, the [m³/hr/kW factor] = 0.42

Therefore:

Maximum discharge volume flow rates = (0.42 x 40) = 16.8 m³/hr
 Minimum discharge volume flow rates = (0.42 x 25) = 10.5 m³/hr

The maximum and minimum m³/hr figures should be compared with the rated capacity of the helical separator. Refer to the Performance Data Table for the rated capacities.

The general recommendation is that the calculated maximum flow should not exceed the rated capacity of the separator. Also, the minimum flow should not be below 25% of the rated capacity. Using these m³/hr figures, the recommended helical separator selection is either model S-5190-CE or SN-5290-CE, both with a rated capacity of 18.7 m³/hr. The final selection depends on whether or not the user requires a separator model with a removable/cleanable oil float assembly.

Additional notes on selection:-

1. The 25% of minimum rated recommendation capacity rule is to optimise efficiency. Below this load factor, the efficiency of the separator will decrease. On systems with extreme unloading conditions, one separator per compressor should be used rather than one separator for a common discharge line.
2. Understanding the system refrigeration capacity and the percentage of full and low load run times can also be helpful in selecting the separator.
3. In cases where the maximum discharge has been exceeded by only a minimal amount and the system has unloading characteristics, select the smaller separator. It is not recommended to oversize.

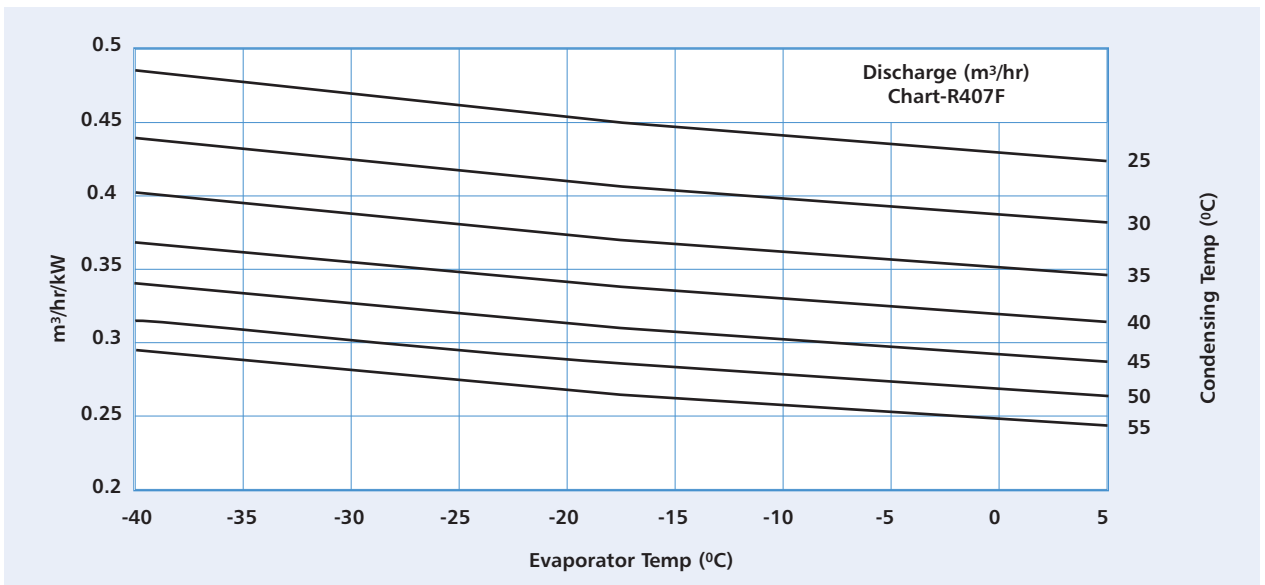
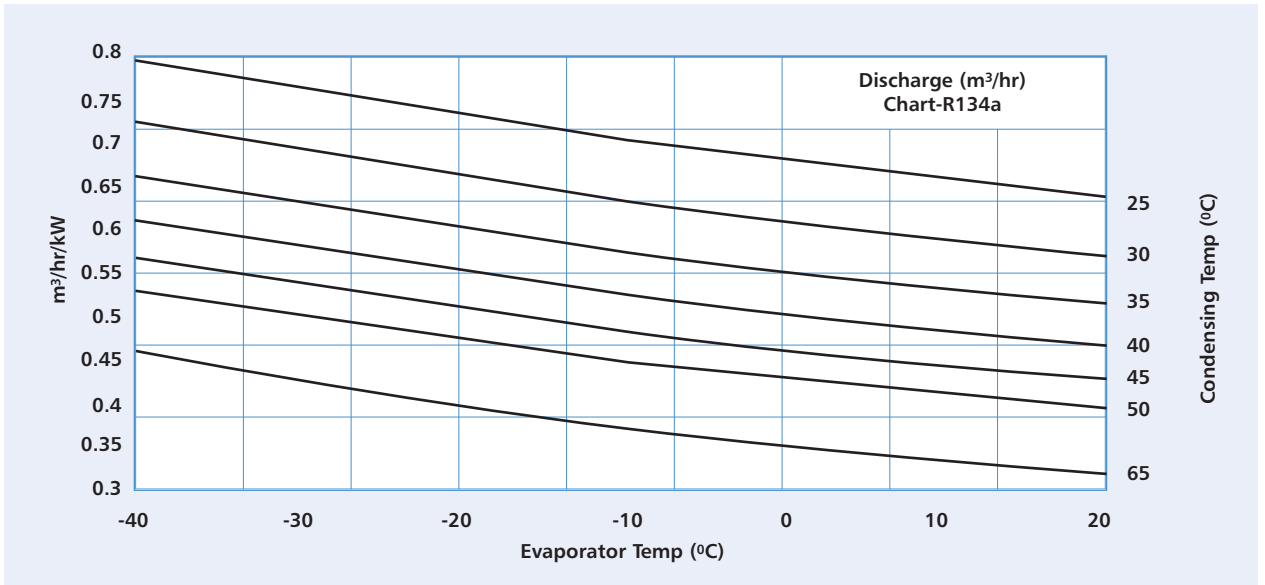
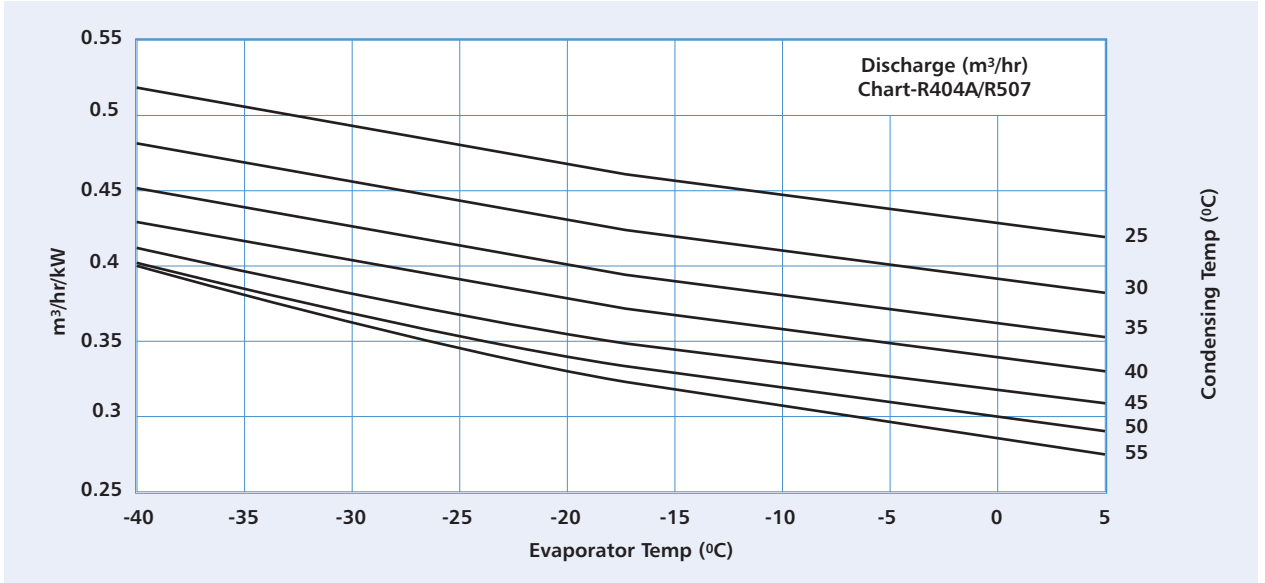

Helical Separator Selection using the Flow Rate Calculation

To use the Flow Rate Calculation method, the maximum and minimum system mass flow rates are required along with the density of the gas at the inlet to the separator. These mass flow rates can either be calculated from first principles or by using refrigeration cycle analysis software. In this way, superheating (useful and un-useful), sub-cooling, etc. can be accounted for in the mass flow rate calculation.

The gas density at inlet to the separator is a function of both pressure and temperature. The gas density should be taken at a pressure equal to the condensing saturation pressure. The inlet gas temperature is dictated by a number of system design factors including compressor performance. The gas will be in a superheated state.

Example

Refrigerant CO₂ (R744)

Maximum refrigeration capacity = 62 kW

Minimum refrigeration capacity = 40 kW

Evaporating temperature = -35°C

Condensing temperature (Cascade) = 0°C

Degree of superheat, useful = 5K

Degree of superheat, un-useful = 6K

Degree of sub-cooling = 2K

From calculation:-

Maximum mass flow rate = 904 kg/hr

Minimum mass flow rate = 583 kg/hr

Gas density, superheated, at inlet to separator = 63.5 kg/m³
(for a separator inlet temperature of 60°C)

Note: Mass flow rate = [(kW refrigeration/ refrigerating effect) x 3600]

Use the equation:-

$$\text{Discharge volume flow rate} = \frac{\text{Mass flow rate}}{\text{Gas density}}$$

Hence for this example:-

$$\text{Calculated maximum discharge volume flowrate} = \frac{904}{63.5} = 14.2 \text{ m}^3/\text{hr}$$

$$\text{Calculated minimum discharge volume flowrate} = \frac{583}{63.5} = 9.2 \text{ m}^3/\text{hr}$$

Using these m³/hr figures, the recommended helical separator selection is model SH-5188-CE (reference additional note 3 for guidance on minimal under-sizing).

Installation – Main Issues

1. Oil separators are not 100% efficient, so installing an oil separator should not be viewed as a replacement for oil traps, suction line accumulators or good oil return piping practices.
2. To avoid damaging the needle valve, oil pre-charge is required. Refer to the Performance Data Table for pre-charge quantity.
3. Install the oil separator vertically and reasonably close to the compressor. Proper piping practice should be adopted to prevent excessive loads or vibration at the inlet and outlet connections. The separator must be properly supported at the bottom M10 stud or mounting feet interface.
4. A check valve should be located downstream of the outlet connection. This check valve is to prevent liquid refrigerant migrating from the condenser.

HELICAL OIL SEPARATOR-RESERVOIRS

The function of a Helical Oil Separator-Reservoir is to remove oil from the discharge gas and return it to the compressor. This helps maintain the compressor crankcase oil level and raises the efficiency of the system by preventing excessive oil circulation.

Applications

Helical oil separator-reservoirs can be used in a variety of applications. Common applications include multi-compressor racks. Helical oil separator-reservoirs are intended for High Pressure Oil Management Systems.

These products are designed for use with scroll and reciprocating type compressors. They are not recommended for screw or rotary vane compressors. The standard product range is designed for use with HFC refrigerants, along with their associated oils.

Please contact Henry Technologies for new or special applications.

How it works

Upon separator entry, refrigerant gas containing oil in aerosol form encounters the leading edge of the helical flighting. The gas/oil mixture is centrifugally forced along the spiral path of the helix causing heavier oil particles to spin to the perimeter, where impingement with a screen layer occurs.

The screen layer functions as both an oil stripping and draining medium. Separated oil flows downward along the boundary of the shell through a baffle and into an oil collection chamber at the bottom of the separator.

The specially engineered baffle isolates the oil chamber and eliminates oil re-entrainment by preventing turbulence. The virtually oil free refrigerant gas then exits through a screen fitting just below the lower edge of the helical flighting.

Oil separator-reservoirs do not have an oil float assembly. Instead, a dip tube is located in the oil chamber that feeds oil to the compressor, via a rotalock valve. With proper selection, an oil separation efficiency of up to 99% can be achieved.

Main Features

- Patented Henry Technologies Design[#]
- High oil separation efficiency - up to 99%
- Low pressure drop
- No blocked elements because of too much oil in the system
- No oil blow-out at start up from oil left in a coalescing element
- Integrated oil reservoir

US Patents 5113671, 5404730 & 5271245; Mexico 173552; Denmark, France, UK & Italy 0487959; Germany P69106849.6-08; Taiwan UM-74863; & other worldwide patents pending



Technical Specification

For all models, excluding SH series:-

Allowable operating pressure = 0 to 31 barg
Allowable operating temperature = -10°C to +130°C

For SH models:-

Allowable operating pressure = 0 to 45 barg
Allowable operating temperature = -10°C to +110°C

Materials of Construction

The main components; shell, end caps and connections are made from carbon steel.

HELICAL OIL SEPARATOR-RESERVOIRS														
Part No	Conn Size (inch)	Dimensions (mm)								Mounting details	Drawing reference	Oil Capacity (l)	Weight (kg)	CE Cat
		ØA	B	C	D	E	F	G	ØH					
S-5387-6L-CE	7/8 ODS	102 & 152	699	74	76	48	222	201	113	3 x Ø14mm slots	fig.1	5.7	11	Cat II
S-5388-6L-CE	1 1/8 ODS	102 & 152	682	75	78	48	207	201	113	3 x Ø14mm slots	fig.2	5.4	11	Cat II
S-5388-CE	1 1/8 ODS	102 & 152	813	75	78	48	222	311	113	3 x Ø14mm slots	fig.3	7.6	13	Cat II
S-5390-CE	1 3/8 ODS	152	850	108	91	48	222	311	113	3 x Ø14mm slots	fig.4	7.6	16	Cat II
S-5392-CE	1 5/8 ODS	152	900	108	98	48	222	311	113	3 x Ø14mm slots	fig.4	7.6	16	Cat II
S-5394-CE	2 1/8 ODS	152	902	114	105	48	222	311	113	3 x Ø14mm slots	fig.4	7.6	16	Cat II
S-5422-CE	2 1/8 ODS	219	699	148	164	N/A	127	149	282	3 x Ø14mm slots	fig.5	8.4	40	Cat II
S-5423-CE	2 5/8 ODS	273	790	183	201	N/A	161	173	339	3 x Ø14mm slots	fig.5	14.8	52	Cat III
S-5424-CE	3 1/8 ODS	324	784	215	229	N/A	99	166	388	3 x Ø14mm slots	fig.5	17	63	Cat III

HIGH PRESSURE RANGE • HELICAL OIL SEPARATOR-RESERVOIRS														
Part No	Conn Size (inch)	Dimensions (mm)								Mounting details	Drawing reference	Oil Capacity (l)	Weight (kg)	CE Cat
		ØA	B	C	D	E	F	G	ØH					
SH-5382-1.5L-CE	1/2 ODS	102	501	70	81	41	175	71	N/A	M10	fig.6	1.5	4.6	Cat I
SH-5388-1.5L-CE	1 1/8 ODS	102	472	70	85	51	142	71	N/A	M10	fig.6	1.5	4.6	Cat I
SH-5388-2.5L-CE	1 1/8 ODS	102	625	75	85	51	282	71	N/A	M10	fig.6	2.5	5.6	Cat I
SH-5390-CE	1 3/8 ODS	152	947	108	140	51	222	362	100	3 x Ø14mm slots	fig.4	7.7	15.5	Cat II
SH-5392-CE	1 5/8 ODS	152	998	108	143	51	222	362	100	3 x Ø14mm slots	fig.4	7.7	16.2	Cat II

Performance data

This table provides a summary of the kW capacity of each separator for fixed evaporating and condensing temperatures. This table can be used as a quick reference guide. However, the Selection Guidelines are recommended for helical separator sizing.

Part No	Capacity in kW of refrigeration at nominal evaporator temperature						Maximum discharge volume (m³/hr)
	R404A/507		R134a		R407F		
	-40°C	5°C	-40°C	5°C	-40°C	5°C	
SH-5382-1.5L-CE	5.3	7	3.5	5.3	6.8	8	2.6
S-5387-6L-CE	23	30	15.8	19.4	26.7	31.3	10.2
S-5388-6L-CE, S-5388-CE, SH-5388-1.5L-CE & SH-5388-2.5L-CE	29.8	38.7	21.1	26.4	35.6	41.7	13.6
S-5390-CE & SH-5390-CE	42.2	52.8	28.2	35.2	49	57.3	18.7
S-5392-CE & SH-5392-CE	52.8	66.9	38.7	45.8	62.4	72.9	23.8
S-5394-CE	84.4	109	63.4	73.8	98	115	37.4
S-5422-CE	109	144	77.4	95	129	151	49.3
S-5423-CE	225	292	162	197	267	312	102
S-5424-CE	352	461	253	310	419	490	159.8

Notes:-
1. All data is for a 38°C condensing temperature, 18°C suction temperature and on connection size being the same as the compressor discharge valve

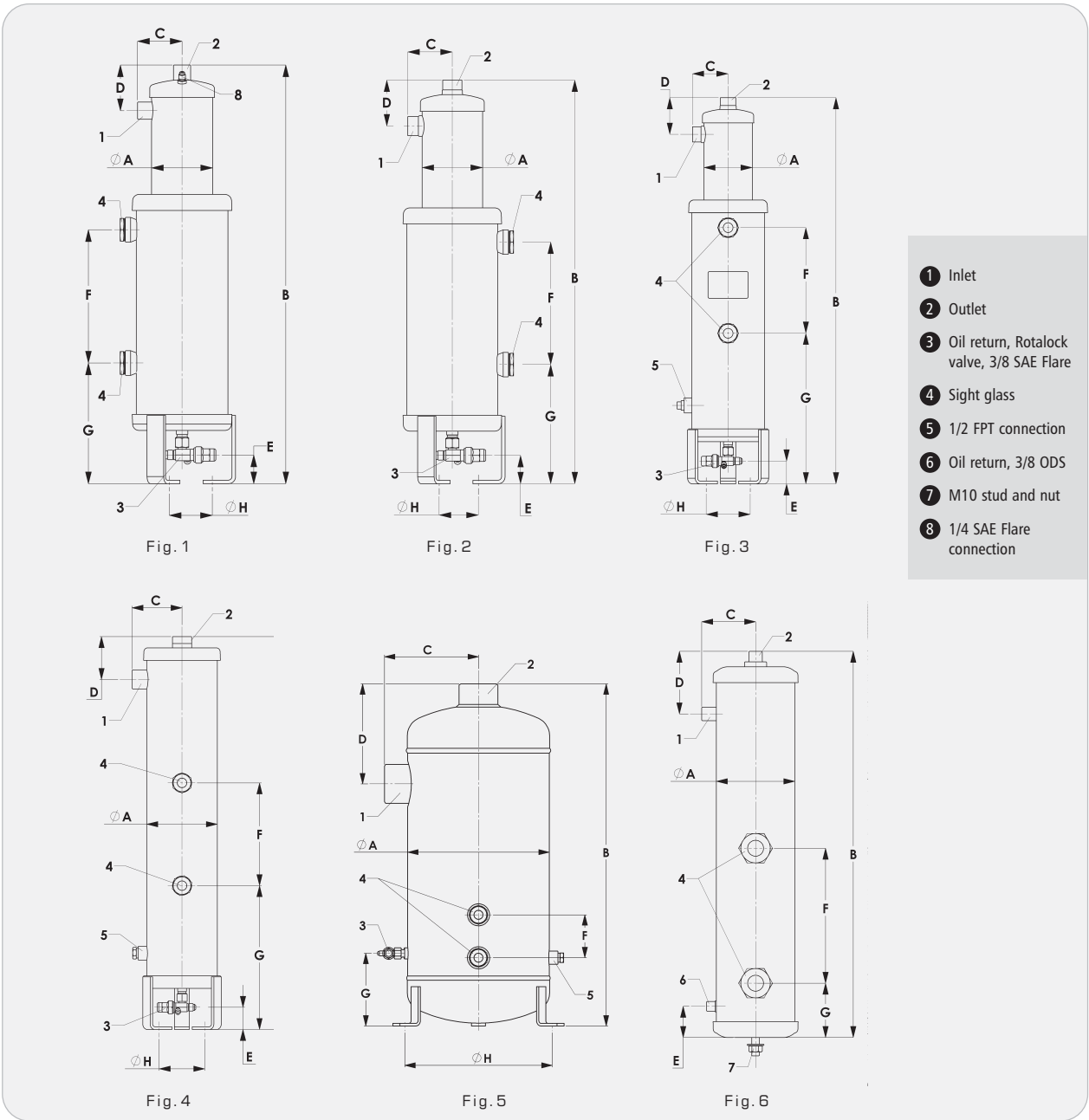

Selection Guidelines

Refer to Helical Oil Separator Section for guidance. The same rules apply.

Installation – Main Issues

1. Oil separator reservoirs are not 100% efficient, so installing this product should not be viewed as a replacement for oil traps, suction line accumulators or good oil return piping practices.
2. Install the unit vertically and reasonably close to the compressor. Proper piping practice should be adopted to prevent excessive loads or vibration at the inlet and outlet connections. The separator must be properly supported at the mounting feet interface.
3. A check valve should be located downstream of the outlet connection. This check valve is to prevent liquid refrigerant migrating from the condenser.

CONVENTIONAL OIL SEPARATORS

The function of a Conventional Oil Separator is to remove oil from the discharge gas and return it to the compressor, either directly or indirectly. This helps maintain the compressor crankcase oil level and raises the efficiency of the system by preventing excessive oil circulation.

Applications

Conventional oil separators can be used in a wide variety of applications.

Common applications include multi-compressor racks and remote condensing units.

Conventional oil separators are intended for Low Pressure Oil Management Systems, using HCFC and HFC refrigerants along with their associated oils.

These separators are designed for use with scroll and reciprocating type compressors. They are not recommended for screw or rotary vane compressors.

How it works

Oil-laden refrigerant gas from the compressor enters the separator and passes through an inlet screen. On entering the separator, the velocity of the gas is reduced. This reduction in velocity causes a change in momentum. The fine oil particles collide with one another to form heavier particles, which adhere to the inlet screen and inside wall of the separator.

The gas then passes through an outlet screen where final separation takes place. Refrigerant gas, with the majority of oil removed, then exits the separator.

The separated oil falls to the bottom of the separator where a float operated needle valve returns the oil to the crankcase or oil reservoir in the same way as the helical oil separator.

With proper selection, oil separation efficiency is typically 80%.

Main Features

- Low pressure drop
- Cleanable/replaceable oil float assemblies for S-57*, S-58* and S-19* models

Technical Specification

Allowable operating pressure = 0 to 31 barg

Allowable operating temperature = -10°C to +130°C

Materials of Construction

The main components; shell, end caps and connections are made from carbon steel. The oil float is made from stainless steel. The needle valve seat is made from steel.



Part No	Conn Size (inch)	Dimensions (mm)						Mounting details	Drawing reference	Weight (kg)	Pre-charge qty (l)	CE Cat
		Ø A	B	C	D	E	Ø F					
S-5580	1/4 ODS	102	210	48	N/A	N/A	N/A	M10	fig.1	2	0.4	SEP
S-5581	3/8 ODS	102	210	48	N/A	N/A	N/A	M10	fig.1	2	0.4	SEP
S-5582	1/2 ODS	102	260	48	N/A	N/A	N/A	M10	fig.1	3	0.4	SEP
S-5585-CE	5/8 ODS	102	362	48	N/A	N/A	N/A	M10	fig.1	4	0.4	Cat I
S-5587-CE	7/8 ODS	102	451	48	N/A	N/A	N/A	M10	fig.1	5	0.4	Cat I
S-5588-CE	1 1/8 ODS	102	533	48	N/A	N/A	N/A	M10	fig.1	5	0.4	Cat I
S-5590-CE	1 3/8 ODS	102	540	48	N/A	N/A	N/A	M10	fig.1	5	0.4	Cat I
S-5882	1/2 ODS	102	260	48	140	N/A	N/A	M10	fig.2	4	0.4	SEP
S-5885-CE	5/8 ODS	102	362	48	140	N/A	N/A	M10	fig.2	6	0.4	Cat I
S-5887-CE	7/8 ODS	102	451	48	140	N/A	N/A	M10	fig.2	6	0.4	Cat I
S-5888-CE	1 1/8 ODS	102	533	48	140	N/A	N/A	M10	fig.2	7	0.4	Cat I
S-5890-CE	1 3/8 ODS	102	540	48	140	N/A	N/A	M10	fig.2	7	0.4	Cat I
S-5687-CE	7/8 ODS	152	283	76	N/A	N/A	N/A	M10	fig.1	7	0.9	Cat I
S-5688-CE	1 1/8 ODS	152	391	76	N/A	N/A	N/A	M10	fig.1	8	0.9	Cat I
S-5690-CE	1 3/8 ODS	152	395	76	N/A	N/A	N/A	M10	fig.1	8	0.9	Cat I
S-5692-CE	1 5/8 ODS	152	473	76	N/A	N/A	N/A	M10	fig.1	10	0.9	Cat II
S-5694-CE	2 1/8 ODS	152	486	76	N/A	N/A	N/A	M10	fig.1	10	0.9	Cat II
S-5792-CE	1 5/8 ODS	152	743	121	127	203	223	2 x Ø 14mm slots	fig.3	12	0.7	Cat II
S-5794-CE	2 1/8 ODS	152	751	117	133	203	223	2 x Ø 14mm slots	fig.3	12	0.7	Cat II
S-1901-CE	1 5/8 ODS	219	534	89	N/A	86	160	3 x Ø 14mm slots	fig.4	20	0.7	Cat II
S-1902-CE	2 1/8 ODS	219	533	89	N/A	86	160	3 x Ø 14mm slots	fig.4	20	0.7	Cat II
S-1903-CE	2 5/8 ODS	273	546	118	N/A	71	214	3 x Ø 14mm slots	fig.4	27	0.7	Cat II
S-1904-CE	3 1/8 ODS	324	655	141	N/A	110	268	3 x Ø 14mm slots	fig.4	39	0.7	Cat II

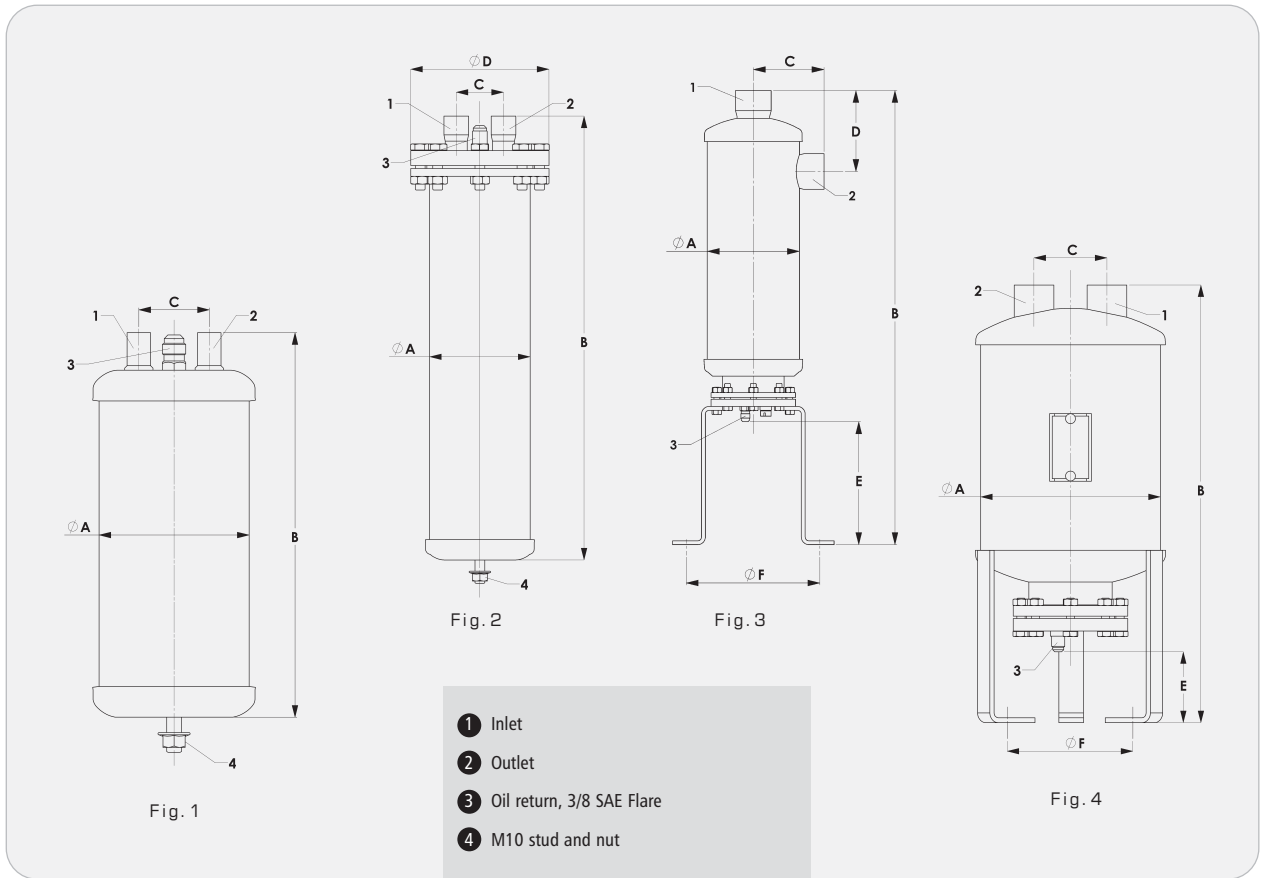

CONVENTIONAL OIL SEPARATORS

Performance data

This table provides a summary of the kW capacity of each separator for fixed evaporating and condensing temperatures.

This table can be used as a quick reference guide. However, the Selection Guidelines are recommended for conventional oil separator sizing.

Part No	Capacity in kW of refrigeration at nominal evaporator temperature						Maximum discharge volume (m ³ /hr)
	R404A/507		R134a		R407F		
	-40°C	5°C	-40°C	5°C	-40°C	5°C	
S-5580	2.9	3.7	3.1	3.5	3.4	4	1.3
S-5581	3.8	4.9	4.2	4.7	4.5	5.2	1.7
S-5582, S-5882	5.7	7.4	6.3	7.1	6.8	8	2.6
S-5585-CE, S-5885-CE	15.2	19.7	16.8	19	17.8	20.8	6.8
S-5587-CE, S-5887-CE	22.8	29.5	25.1	28.4	26.7	31.3	10.2
S-5588-CE, S-5888-CE	30.4	39.3	33.5	37.8	35.6	41.7	13.6
S-5590-CE, S-5890-CE	38	49.2	42	47.3	44.5	52.1	17
S-5687-CE	28.5	36.9	31.4	35.4	33.5	39.2	12.8
S-5688-CE	34.2	44.2	37.7	42.5	40.1	46.9	15.3
S-5690-CE	41.8	54.1	46.1	52	49	57.3	18.7
S-5692-CE, S-5792-CE	53.2	68.8	58.6	66.1	62.4	72.9	23.8
S-5694-CE, S-5794-CE	85.6	110	94.3	106	100	117	38.3
S-1901-CE	68.4	88.5	75.4	84	80.2	93.7	30.6
S-1902-CE	102	132	113	127	120	141	45.9
S-1903-CE	186	240	205	231	218	255	83.3
S-1904-CE	258	334	284	321	301	352	115

Notes:-
1. All data is for a 38°C condensing temperature, 18°C suction temperature and on connection size being the same as the compressor discharge valve.

Selection Guidelines

The most important parameter for selection is the discharge volumetric flow rate, expressed in m³/hr. This is the calculated volume flow rate at entry to the oil separator. It is not to be confused with the compressor displacement or swept volume.

A quick method is to use the selection graphs. For HCFC and HFC refrigerants, the same graphs apply for both conventional and helical oil separators. Conventional separators are not suitable for use with ammonia hence the R717 graph should not be used.

As with the helical separators, where a higher degree of accuracy is required to calculate the m³/hr, the flow rate calculation method is recommended. The flow rate calculation method is also recommended for special applications.

Conventional Separator Selection using the Graphs

To use the selection graphs, the refrigerant type, maximum refrigeration capacity, minimum refrigeration capacity, evaporating temperature and the condensing temperature is required.

Example:

Refrigerant R404A

Maximum refrigeration capacity = 100 kW

Minimum refrigeration capacity = 50 kW

Evaporating temperature = -10°C

Condensing temperature = +40°C

From the R404A graph, follow the -10°C evaporator temperature line to the intersection of the 40°C condensing temperature line.

Extend a line horizontally from this point to the m³/hr/kW factor.

Multiply this factor by the maximum and minimum refrigeration capacities to compute the maximum and minimum discharge volume flow rates.

From the R404A graph, the [m³/hr/kW factor] = 0.355

Therefore:-

Maximum discharge volume flow rates = (0.355 x 100) = 35.5 m³/hr

Minimum discharge volume flow rates = (0.355 x 50) = 17.75 m³/hr

The maximum and minimum m³/hr figures should be compared with the rated capacity of the conventional separator. Refer to the Performance Data Table for the rated capacities.

The general recommendation is that the calculated maximum flow should not exceed the rated capacity of the separator. Also, the minimum flow should not be below 33% of the rated capacity.

Using these m³/hr figures, the recommended conventional separator selection is either model S-5694-CE or S-5794-CE, both with a rated capacity of 38.3 m³/hr. The final selection depends on whether or not the user requires a separator model with a removable/cleanable oil float assembly.

Additional notes on selection:-

1. The 33% minimum recommendation rule is to optimise efficiency. Below this load factor, the efficiency of the separator will decrease. On systems with extreme unloading conditions, one separator per compressor should be used rather than one separator for a common discharge line.
2. Understanding the system refrigeration capacity and the percentage of full and low load run times can also be helpful in selecting the separator.
3. In cases where the maximum discharge has been exceeded by only a minimal amount and the system has unloading characteristics, select the smaller separator. It is not recommended to oversize.

Installation – Main issues

Same as for helical oil separators.

TRANSCRITICAL CO₂ OIL MANAGEMENT CONTROLS

The function of a helical oil separator is to efficiently remove oil from the discharge gas and return it to the compressor, either directly or indirectly. This helps maintain the compressor crankcase oil level and raises the efficiency of the system by preventing excessive oil circulation.

The function of an Oil Reservoir is to provide a holding charge of oil. The amount of oil circulating in a system varies depending on the operating conditions and the oil reservoir caters for these fluctuations by providing additional storage capacity.

Efficiency

To establish the oil separator efficiency when used on transcritical CO₂ applications Henry Technologies commissioned independent testing. The chart shows the resultant oil separator efficiency at capacities of 25% to 103%. Efficiency levels of up to 97% were recorded. The tests utilised a semi-hermetic compressor with a variable speed drive motor to enable the capacity to be adjusted.

There are many factors that affect oil separator efficiency such as; discharge gas temperature and pressure; compressor oil carry-over and the density of the discharge gas and oil. Consequently oil separator efficiency varies on each system.

Separation Efficiency

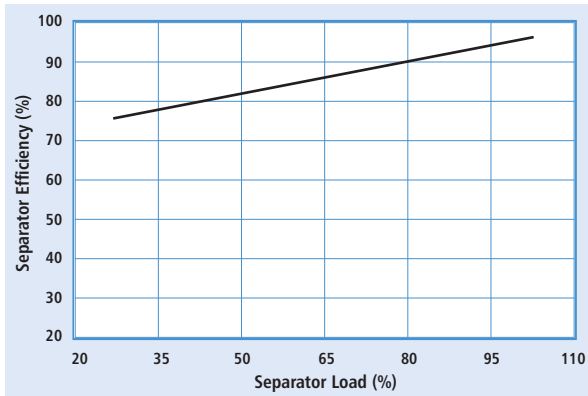

Main Features

Separator/Separator-Reservoir

- High oil separation efficiency - up to 97%
- Consistent low pressure drop
- No clogging elements because of too much oil in the system
- No oil blow-out at start up from oil left in a coalescing element
- Maintenance-free
- Oil level sensor port

Oil Reservoir

- Two sizes available, 6.0 litres and 11.0 litres
- Clear sight glasses
- Oil level sensor port

Materials of Construction

The main components; shell, end caps and connections are made from carbon steel.

Technical Specification

Allowable operating temperature = 0°C to +140°C

Allowable operating pressure = 0 to 130 barg

Oil Separator

Part No	Conn Size (Inch)	Dimensions (mm)								Mounting details	Drawing reference	Pre-charge qty (l)	Weight (kg)	CE Cat
		ØA	B	C	D	ØE	F	G	H					
STH-5193	1/2 NPT	168.3	638	191	202	231	202	N/A	45	3 x 14mm slots	fig.1	0.6	31.0	Cat III
STH-5196	3/4 NPT	168.3	697	191	261	231	261	N/A	45	3 x 14mm slots	fig.1	0.6	31.0	Cat III
STH-5198	1 NPT	168.3	747	191	261	231	261	N/A	45	3 x 14mm slots	fig.1	0.6	34.0	Cat III

Oil Separator-Reservoir

Part No	Conn Size (Inch)	Dimensions (mm)								Mounting details	Drawing reference	Capacity (l)	Weight (kg)	CE Cat
		ØA	B	C	D	ØE	F	G	H					
STH-5398	1 NPT	168.3	992	191	261	231	271	265	45	3 x 14mm slots	fig.2	6.7*	45.2	Cat III

*Indicates reservoir capacity

Oil Reservoir

Part No	Conn Size (Inch)	Dimensions (mm)								Mounting details	Drawing reference	Capacity (l)	Weight (kg)	CE Cat
		ØA	B	C	D	ØE	F	G	H					
STH-9109	3/8 NPT	168.3	623	199	240	231	209	120	120	3 x 14mm slots	fig.3	6.0*	28.0	Cat III
STH-9108	3/8 NPT	168.3	930	199	547	231	209	269	278	3 x 14mm slots	fig.3	11.0*	41.5	Cat III

*Indicates reservoir capacity

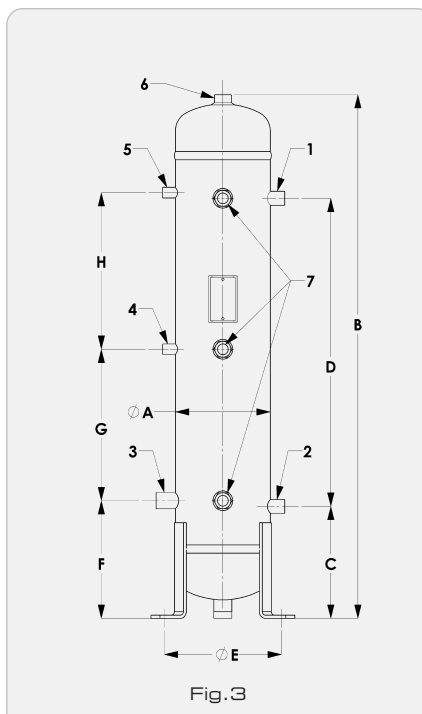
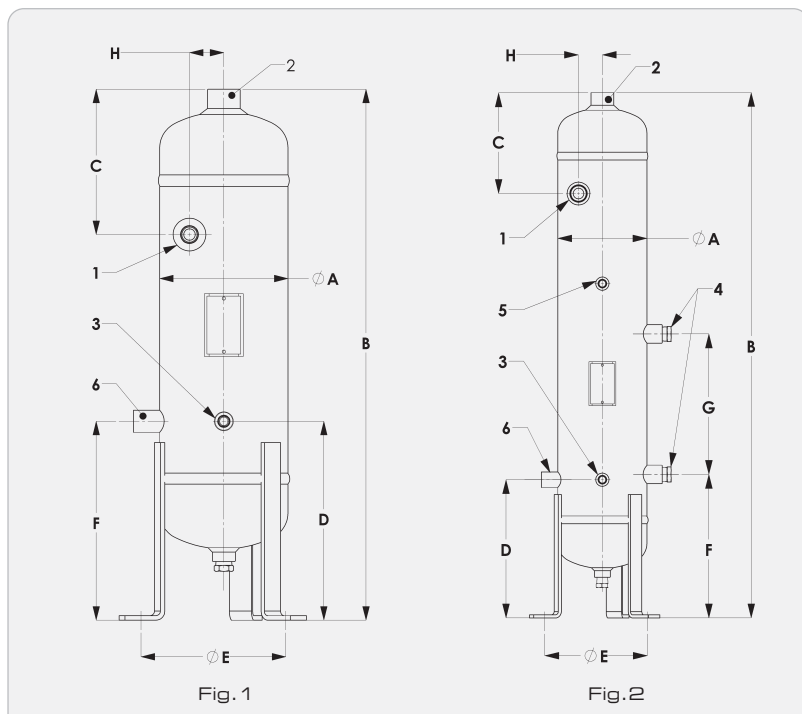

- 1 Inlet
- 2 Outlet
- 3 Oil return, 3/8 NPT
- 4 Sight glass
- 5 Port, 3/8 NPT
- 6 Level control conn, 1/2 NPT

- 1 Inlet
- 2 Outlet
- 3 Level control conn, 1/2 NPT
- 4 Charging conn, 1/4 NPT
- 5 Vent valve conn, 1/4 NPT
- 6 Relief valve conn, 1/2 NPT
- 7 Sight glass (centre sight glass on STH-9108 only)

Performance Data

This table provides a summary of the kW capacity of each separator for fixed evaporating and condensing temperatures. The table can be used as a quick reference guide. However, the Selection Guidelines are recommended for helical separator sizing.

Separator performance data

Part No	Capacity in kW of refrigeration at nominal evaporator temperature (°C)						Vol discharge (m³/h)
	-30	-20	-10	0	10	15	
STH-5193	14	15.3	16.6	17.9	19.1	19.7	2.6
STH-5196	36.6	39.9	43.4	46.7	49.9	51.4	6.8
STH-5198	54.9	59.9	65.1	70.1	74.9	77.1	10.2

All data is based on 90 bar high pressure, 35°C gas cooler, 8K suction gas superheat and 5K useful superheat

Separator-Reservoir performance data

Part No	Capacity in kW of refrigeration at nominal evaporator temperature (°C)						Vol discharge (m³/h)
	-30	-20	-10	0	10	15	
STH-5398	54.9	59.9	65.1	70.1	74.9	77.1	10.2

All data is based on 90 bar high pressure, 35°C gas cooler, 8K suction gas superheat and 5K useful superheat

Selection Guidelines

The most important parameter for selection is the discharge volumetric flow rate, expressed in m³/hr. This is the calculated volume flow rate at entry to the oil separator. It is not to be confused with the compressor displacement or swept volume.

To calculate the discharge volumetric flow rate, the maximum and minimum system mass flow rates are required along with the density of the gas at the inlet to the separator.

These mass flow rates can either be calculated from first principles or by using refrigeration cycle analysis software. In this way, superheating (useful and un-useful) can be accounted for in the mass flow rate calculation.

The gas density at inlet to the separator is a function of both pressure and temperature. The inlet gas temperature is dictated by a number of system design factors including compressor performance. The gas will be in a superheated state.

Example:

Refrigerant CO₂ (R744)

Maximum refrigeration capacity = 42 kW

Minimum refrigeration capacity = 26 kW

Evaporating temperature = -10°C

Gas cooler outlet = 35°C

High pressure = 90 barg (a)

Suction gas superheat = 5K

Useful superheat = 5K

From analysis software:-

Maximum mass flow rate = 1052 kg/hr

Minimum mass flow rate = 651 kg/hr

Gas density, superheated, at inlet to separator = 162 kg/m³

Note: Mass flow rate = [(kW refrigeration/ refrigerating effect) x 3600

Use the equation:-

$$\text{Discharge volume flow rate} = \frac{\text{Mass flow rate}}{\text{Gas density}}$$

Hence for this example:-

$$\text{Calculated maximum discharge volume flow rate} = \frac{1052}{162} = 6.5 \text{ m}^3/\text{hr}$$

$$\text{Calculated minimum discharge volume flow rate} = \frac{651}{162} = 4.0 \text{ m}^3/\text{hr}$$

Using these m³/hr figures, the recommended helical separator selection is model STH-5196 (reference additional note 3 for guidance on minimal under-sizing).

Additional notes on selection:-

1. It is recommended that the separator is **not** operated below 25% of its rated maximum capacity. This is to optimise efficiency. On systems with extreme unloading conditions, one separator per compressor should be used rather than one separator for a common discharge line.
2. Understanding the system refrigeration capacity and the percentage of full and low load run times can also be helpful in selecting the separator.
3. In cases where the maximum discharge has been exceeded by only a minimal amount and the system has unloading characteristics, select the smaller separator. It is not recommended to oversize.

Installation – Main issues

1. Oil separators are not 100% efficient, so installing an oil separator should not be viewed as a replacement for oil traps, suction line accumulators or good oil return piping practices.
2. An initial oil pre-charge of 0.6l is required.
3. Install the oil separator/separator-reservoir vertically and reasonably close to the compressor. Proper piping practice should be adopted to prevent excessive loads or vibration at the inlet and outlet connections. The separator/separator-reservoir must be properly supported at the bottom mounting feet interface.
4. A check valve should be located downstream of the separator/ separator-reservoir outlet connection. This check valve is to prevent liquid refrigerant migrating from the condenser/gas cooler.

MECHANICAL OIL LEVEL REGULATORS

The function of a Mechanical Oil Level Regulator is to control the oil level in the compressor crankcase. This protects the compressor from damage.

There are two main types of Mechanical oil level regulators - fixed level and adjustable level.

Applications

Mechanical oil level regulators are used in Low Pressure Oil Management Systems. They are designed for use with reciprocating compressors. They are not recommended for scroll compressors.

All regulators are suitable for HCFC and HFC refrigerants, along with their associated oils. The unique features of the SN model allow it to be used in ammonia, R410A and sub-critical CO₂ applications.

How it works

Oil is fed to the regulator via an inlet connection. An internal needle valve either allows or shuts off an oil supply to the regulator. An internal ball float controls the position of the needle valve. During compressor operation, the crankcase oil level reduces. A reduction in oil level activates the regulator, which ensures the correct crankcase oil level is achieved and maintained.

The adjustable regulator has an in-built mechanism that allows the ball float to be adjusted up or down. This means that the crankcase oil level can be adjusted, in line with the compressor manufacturer's guidelines. The fixed level regulator does not have an adjusting feature hence the crankcase will be maintained at a fixed oil level.

Some regulator models are fitted with an equalisation connection that enables the oil levels between several compressors to be balanced.

In the majority of cases, Henry Technologies oil level regulators can be fitted directly to the compressor sight glass port. Where direct mounting is not possible, a separate adaptor can be used. Refer to Adaptor Kit table.

Main Features

- Proven needle valve design
- Stainless steel ball float
- Special mounting flange - allows direct fitting to standard compressors
- Premium quality neoprene seals
- Seal adaptor kit supplied with each model
- Visual indication of oil level via large sight glass
- Double O-ring stem seal design - adjustable model
- Easy adjustment mechanism - adjustable model



Technical Specification

For all models, excluding SN model:-

Allowable operating pressure = 0 to 31 barg

Allowable operating temperature = 0°C to +130°C

For SN model:-

Allowable operating pressure = 0 to 45 barg

Allowable operating temperature = -10°C to +110°C

Refer to table for the allowable oil pressure differential for the Henry range of regulators.

Important information

1. As a result of a modification to the Bitzer oil ventura device in May 1997, it is no longer necessary to provide an oil guard on the oil level regulator.
2. Copeland confirm a 1/2 sight glass oil level is acceptable, rather than 1/4 sight glass, for all compressors fitted with an oil management system.

Materials of Construction

The main components; shell, end caps and connections are made from carbon steel. The ball float is made from stainless steel. The needle valve seat is made from either brass or steel, dependent on model.

Part No	Regulator type	Sight glass oil level	Equalisation	Allowable oil pressure differential, bar	Drawing reference	MWP (barg)	Weight (kg)	Compressor sight glass connection	CE Cat
S-9510	Fixed	1/2	No	0.35 to 2.1	fig.1	31	2.20	3-Bolt 1.7/8" B.C. & 4-Bolt 50mm B.C.	SEP
S-9510E	Fixed	1/2	Yes	0.35 to 2.1	fig.1	31	2.20		SEP
S-9510V	Fixed	1/2	No	0.35 to 2.1	fig.2	31	2.10		SEP
S-9530	Adjustable	1/4 to 5/8	No	0.35 to 6.2	fig.3	31	2.30		SEP
*S-9530B	Adjustable	1/4 to 5/8	No	0.35 to 6.2	fig.3	31	2.30		SEP
S-9530E	Adjustable	1/4 to 5/8	Yes	0.35 to 6.2	fig.3	31	2.30		SEP
SN-9530EHP	Adjustable	1/4 to 5/8	Yes	0.35 to 6.2	fig.3	40	2.30		SEP

* As per S-9530 but Bitzer green

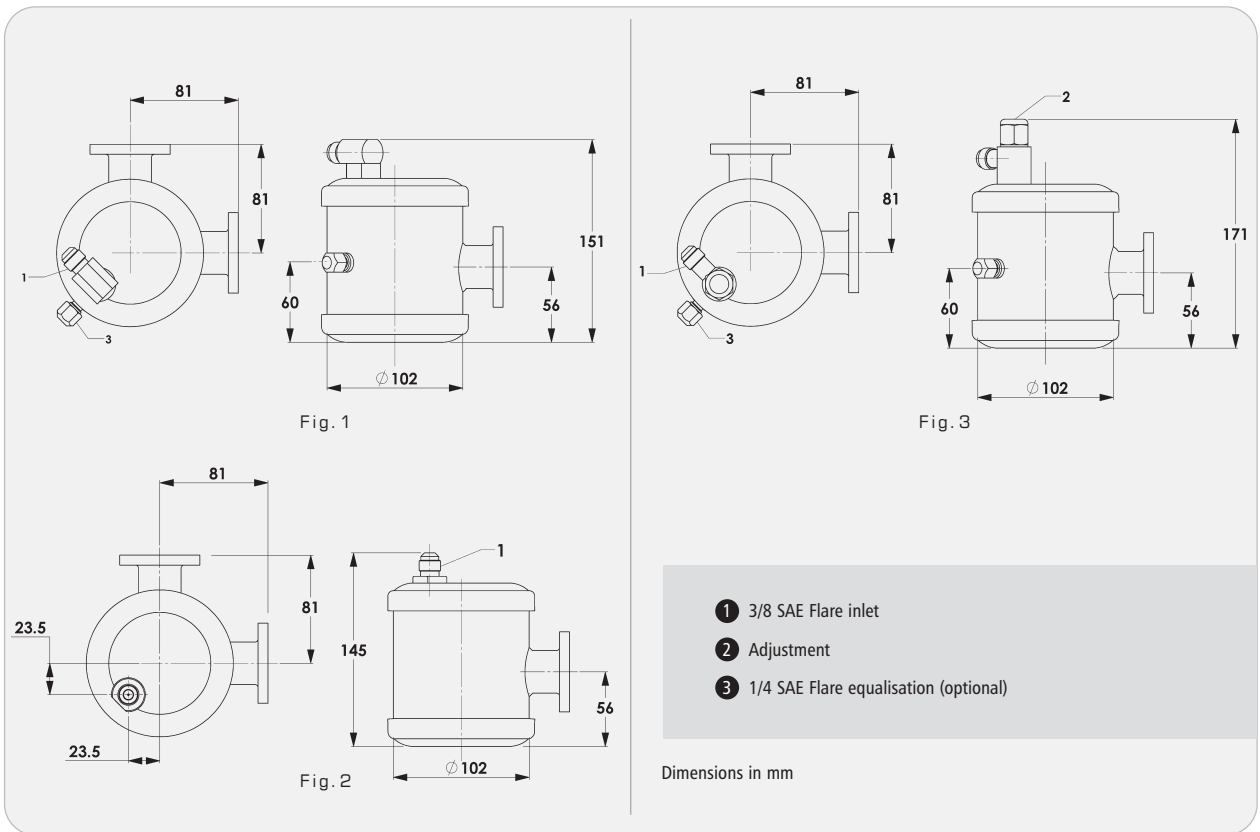

Selection Guidelines

The correct selection depends on the refrigerant type, differential oil pressure acting on the regulator, and the user's preference for crankcase oil level control. Some users prefer the simplicity of model S-9510 while others prefer model S-9530E, owing to the larger pressure differential, oil level adjustment and equalisation features.

Note: Differential oil pressure is the difference between the supply pressure at inlet to the regulator and the pressure inside the compressor crankcase. Gravity pressure head should be included also, if applicable.

Installation – Main issues

1. To protect the regulator from system debris, an oil strainer, oil filter or oil filter drier is recommended.
2. The regulator can be fitted directly to 2, 3 and 4 cylinder compressors and to most 6-cylinder compressors that use a standard 3 or 4 bolt sight glass. For other compressor configurations, an adaptor will be required.
3. The regulator should not be subjected to excessive vibration. The operating differential oil pressure should be within the range of the regulator's specification.
4. The oil level must be set and controlled in line with the compressor manufacturer's guidelines.
5. Full instructions are given in the Product Instruction Sheet included with each regulator.

Compressor Model	Sight Glass Configuration	Adaptor Kit Part Number	CE Cat
Bitzer	4-Bolt 50mm B.C.	3-033-253 (note 1)	SEP
Bitzer Octagon	1 1/8"- 18 Thread	3-033-262	SEP
Bock	4-Bolt 50mm B.C.	3-033-244	SEP
Bristol	15/16"- 20 Thread	3-033-242	SEP
Carrier (DA,DR,5F,5H,06D)	1 1/2"- 18 Thread	3-033-204	SEP
Carrier models (EA,ER,OBE & OBCC)	3 Bolt 1 7/8" B.C.	3-033-201	SEP
Copeland (8R & 8D)	3 Bolt 1 7/8" B.C.	3-033-212	SEP
Copeland Discus (4R,6R,9R,MD,MR,NR)	3 Bolt 1 7/8" B.C.	3-033-201	SEP
Copeland (HA,KA,EA,3A,LA,ER & 3R)	1 1/8"-12 Thread	3-033-202	SEP
Dunham (Bush Big 4)	3 Bolt 1 7/8" B.C.	3-033-201	SEP
Frascold	3 Bolt 1 7/8" B.C.	3-033-201	SEP
Maneurop	1 1/8"-18 Thread	3-033-246	SEP
Prestcold (C,E,R,L & LG)	M42 Thread	3-033-216	SEP
Prestcold (K)	1 1/8"-12 Thread	3-033-202	SEP
Royce	3/4"NPT.Thread	3-033-218	SEP
Schnacke-Grasso	2"-16 Thread	3-033-205	SEP
Tecumseh (P,R,S,PA,RA,SA,CK,CM,CH,CG)	1 1/8"-12 Thread	3-033-202	SEP
Trane (M,R)	3 Bolt 1 7/8" B.C.	3-033-201	SEP
Trane (K)	3/4" NPT Thread	3-033-218	SEP
York (GC,GS,JS)	3 Bolt 1 7/8" B.C.	3-033-201	SEP
Universal adaptor kit	ANY	3-033-217 (note 2)	SEP
Equalisation adaptor kit	3 Bolt 1 7/8" B.C.	3-033-226 (note 3)	SEP
Bitzer	4-Bolt 50mm B.C.	A4448 (note 4)	SEP
Standard seal kit	N/A	A4480 (note 5)	-

Notes:-

- Oil guard feature included. The oil guard feature is only required on Bitzer compressors which were manufactured before May 1997.
- This adaptor kit has a 3 hole flange to mount the regulator. The compressor end of the kit is a 1 1/4" OD steel tube. The existing compressor sight glass gland or flange must be bored out or bushed down to accept the 1 1/4" tube. The tube is then welded or brazed to the reworked gland or flange and installed on the compressor. A sight glass, seals and hardware are included in the kit.
- This kit with its 1/4" male flare connection allows non equalised regulators to be interconnected (equalised).
- This is a shortened version of 3-033-253. The oil guard feature is included. It is designed for the S-95 series regulators.
- This is the standard seal kit supplied with each S-95 series regulator. It includes all the parts in 3-033-201 along with a special sandwich piece and O-ring for sealing a Bitzer 4 bolt sight glass.

Warning: Regulators should not be operated at 1/4 sight glass or below when using an adaptor with an inside diameter smaller than the regulator flange port.

OPTRONIC OIL LEVEL REGULATOR

The function of the Optronic Oil Level Regulator is to control the oil level in the compressor crankcase using proven optical sensor technology. This protects the compressor from damage.

Applications

The Optronic regulator is suitable for both low and high pressure oil management systems. It is designed for use with scroll and reciprocating compressors.

This regulator is approved for HFC refrigerants and POE oils. For other refrigerant/oil combinations, please contact Henry Technologies.

How it works

The Optronic regulator controls the oil in the compressor crankcase at 1/2 sight glass level.

An optical sensor monitors the oil level continuously. When the sensor detects a low oil condition, there is a 15 second time delay prior to oil feed. This is to ensure stability and prevent overflow.

A solenoid valve allows oil to be pulse fed into the compressor at 3 second on/off intervals, to minimise foaming. If demand is not satisfied after 2 minutes of oil feed, a low level alarm is activated by means of a fail-safe electrical contact.

During the alarm condition the regulator will continue to pulse feed. The alarm will automatically reset if the oil returns to a 1/2 sight glass level. The alarm contact can be used to switch off the compressor in the event of a low oil level condition.

The power supply connection is an integral part of the electronic control module. The electronic control module houses a PCB which controls the operation of the Optronic.

The Optronic regulator is fitted to the sight glass port on the compressor and has an integral sight glass that allows visual inspection of the crankcase oil level.

Main Features

- Patented optical sensor technology#
- CE approved
- Approved by compressor manufacturers
- Compact
- Low level alarm
- IP54 protection class
- Easy electrical connection
- Visual LED status display
- No moving parts
- Premium quality neoprene seals
- Male and female electrical connectors supplied with each unit
- Oil sight glass for visual inspection

US patent 5278426

Models

- OP-02 complete with 3/4" NPT adaptor
- OP-02NA supplied with no adaptor



Technical Specification

Allowable operating pressure:	0 to 35 barg
Maximum differential pressure:	24 barg
Maximum ambient temperature:	45°C
Maximum fluid temperature:	80°C
Supply voltage:	24V AC 50/60 Hz
Rated operating current:	0.5 Amps
Electrical connection:	4-pin M12 circular, IEC60947-5-2
Alarm contact:	Volt free, normally open*
Alarm contact rating:	24V DC@2A, 120V AC@2A
Wiring:	4-pin connector
Power supply:	Pins 1 & 2
Alarm contact:	Pins 3 & 4
Protection class:	IP 54
Status LED's:	4
Oil inlet connection:	1/4 SAE Flare
Weight:	1.2 kg

CE marked for EMC directive

* The alarm contacts are closed when power is applied

OPTRONIC OIL LEVEL REGULATOR

Materials of Construction

The main valve body components are made from plated carbon steel.
The electronic control module's enclosure is made from tough ABS plastic.

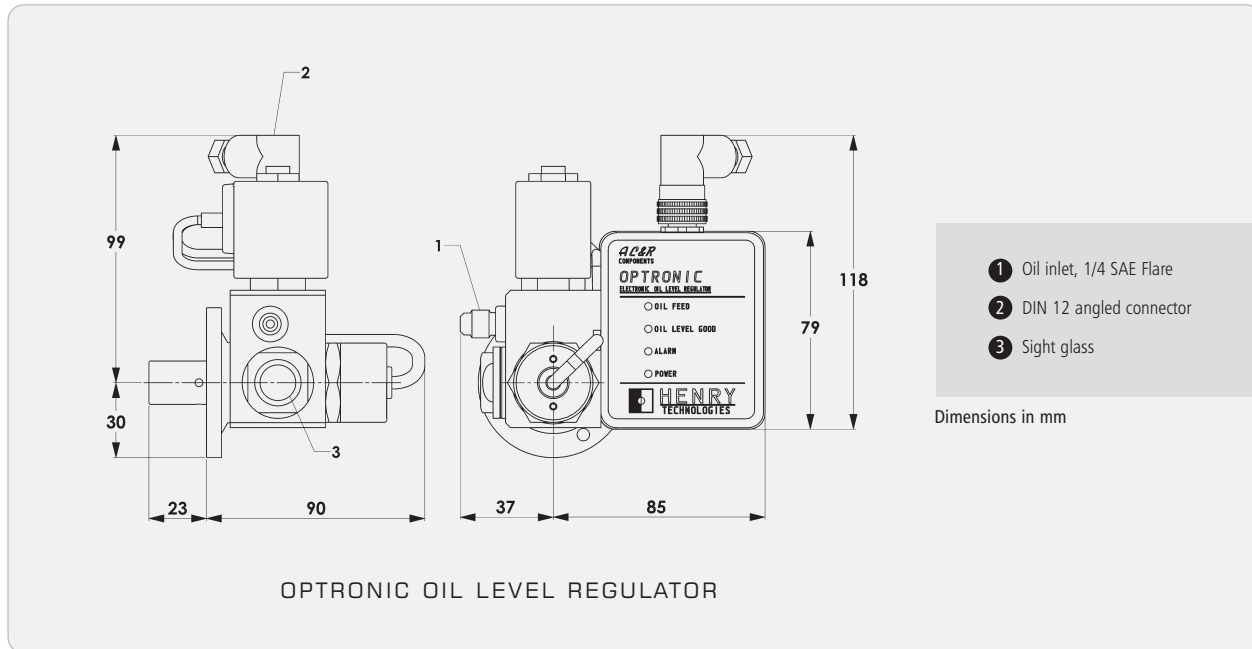

Refer to the table for compressor adaptors:-

OPTRONIC ADAPTORS		
Part No	Compressor Type	Mounting Style
A4134	Bitzer Octagon	1 1/8"-18 UNEF thread with O-ring
A4149	Scroll	3/4" NPT
A4221	Maneurop	1 1/8"-18 UNEF thread with teflon gasket
A4382	Copeland ZR Scroll	1 1/8"-12 UNF thread with O-ring
A4562*	Copeland & Bitzer, up to 4 cylinders	3 & 4 bolt combination flange with O-ring
A4563*	Copeland & Bitzer, up to 6 cylinders	3 & 4 bolt combination flange with O-ring
A4762	Copeland Scroll	1 1/4"-12 UNF thread Rotalock with teflon gasket
A4766	Copeland Scroll	1 3/4"-12 UN thread Rotalock with teflon gasket

* Adaptors are only suitable for Bitzer compressors manufactured after May 1997 as they do not have the oil guard feature

Flow rate data

The flow rate of oil through the Optronic oil regulator is dependent on the pressure differential between the supply line and the compressor crankcase. Gravity pressure level should be included also, if applicable. The graph illustrates typical flow rates at various pressures. The flow can be reduced by inserting the A4775 1/4" flare adaptor.

Installation – Main issues

1. The electronic module will be damaged if the 24V supply voltage is exceeded.
2. Power to the unit should be maintained during compressor running, stand-by and shutdown modes.
3. To protect the regulator from system debris, a filter drier is recommended.

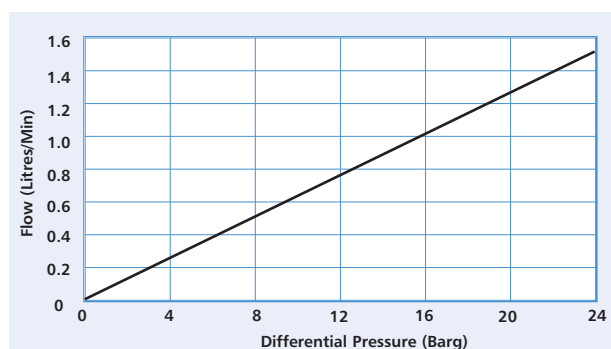

ELECTRO-MECHANICAL OIL LEVEL REGULATORS

The function of an Electro-Mechanical Regulator is to control the oil level in the compressor crankcase. This protects the compressor from damage.

Applications

Electro-Mechanical oil level regulators can be used in Low Pressure Oil Management Systems. Models with a higher operating differential can also be used in High Pressure Oil Management Systems. The S-9030 model fits directly to standard three-bolt compressor sight glass housings. The S-9040R model is designed to fit to compressors with standard threaded sight glass housings. All regulators are suitable for HCFC and HFC refrigerants, along with their associated oils.

Due to foaming concerns, it is not recommended to use this product on a high pressure HCFC/Mineral oil system.

How it Works

The electro-mechanical oil level regulator incorporates a float switch and solenoid valve assembly. The float switch contains two magnetic reed switches. One reed switch is used to open and close the solenoid valve while the other is used for a low level alarm output. The first reed switch is set to achieve the desired operating crankcase oil level.

When the compressor crankcase oil level reduces, the float switch activates the solenoid valve which in turn allows oil to be fed through the regulator into the compressor crankcase. When the correct oil level is achieved, the solenoid valve is shut off. The float switch set point can be adjusted. This adjustment feature allows the user to adjust and control the crankcase oil level.

The second reed switch can be used to activate an alarm and/or isolate the compressor when the oil level drops 1/8" below the user set point. While in the alarm mode, the solenoid valve remains open.

The oil level is adjustable by manually adjusting the position of the float switch. Certain models are fitted with a pulse timer for use on high pressure systems. This feature controls the rate of oil injection.

Main Features

- Proven design
- Adjustable oil level
- Low level alarm
- Reliable float switch operation
- Major components are serviceable
- Oil equalisation connection, S-9030 model

Technical Specification

Power supply: 24V AC

Solenoid valve: 24V AC, 6W, normally closed, 1.6mm orifice

Alarm output rating: 24V AC, 20VA pilot duty

Allowable operating pressure = 0 to 31 barg

Allowable operating temperature = -10°C to +100°C

Allowable operating pressure differential: Refer to table

Materials of Construction

The main body parts are made from carbon steel. A flexible moulded cap is used to protect the solenoid and switch connections.



Installation – Main Issues

1. To protect the regulator from system debris, a filter or filter drier is recommended.
2. The regulator should not be subjected to excessive vibration.
3. The operating oil differential pressure should be within the range of the regulator's specification.
4. The oil level must be set and controlled in line with the compressor manufacturer's guidelines.
5. If the alarm output is used to shut down a compressor, an external time delay should be fitted into the circuit.

ELECTRO-MECHANICAL OIL LEVEL REGULATORS

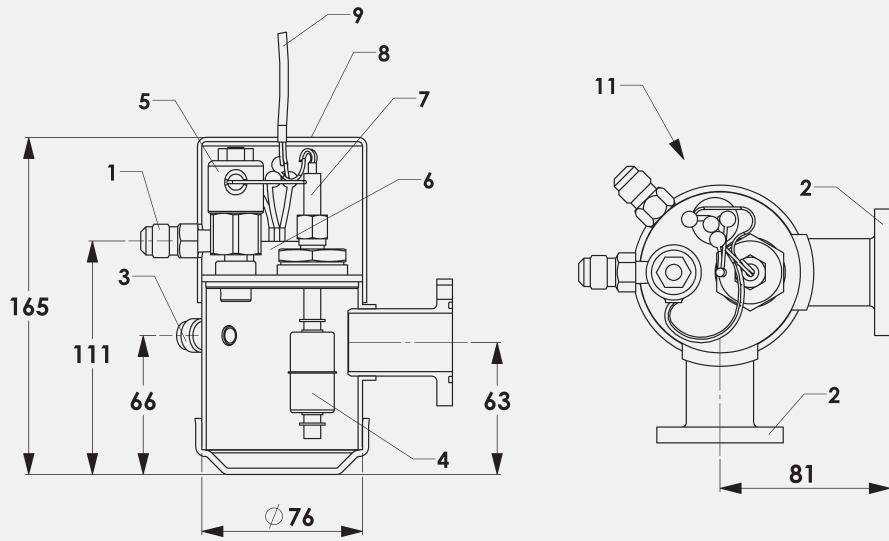

S-9030

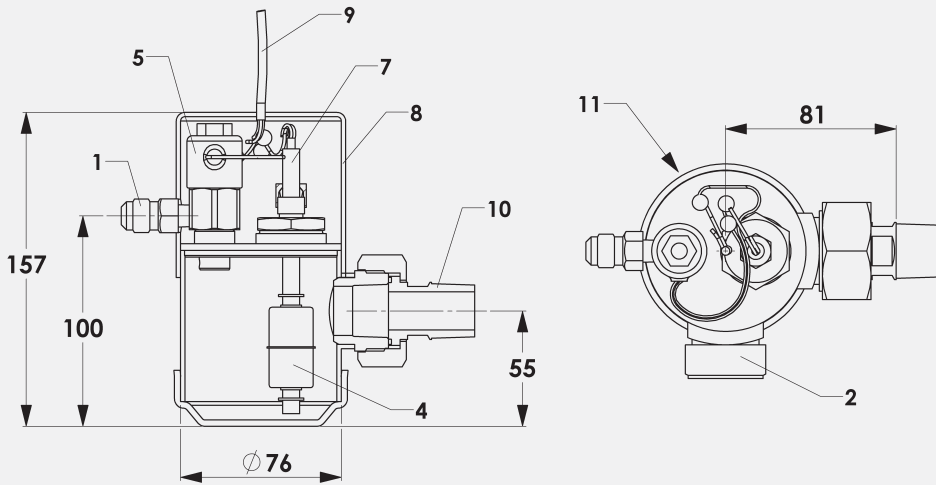

S-9040R

- 1 Inlet, 3/8 SAE Flare
- 2 Regulator flange
- 3 Equalisation connection
- 4 Float switch
- 5 Solenoid valve
- 6 Pulse timer
- 7 Float switch stem
- 8 Protective cap
- 9 Cable, approx 300mm lg
- 10 Adaptor fitted to mounting flange
- 11 Top view with Protective cap removed

Dimensions in mm

Part No	Operating Pressure Differential (bar)	Pulse Timer	Weight (kg)	CE Cat
S-9030	0.35 - 20.7	Yes	1.84	SEP

Part No	Compressor	Operating Pressure Differential (bar)	Pulse Timer	Weight (kg)	CE Cat
S-9040R	Copeland Scroll	0.35 - 6.2	No	1.72	SEP

OIL RESERVOIRS

The function of an Oil Reservoir is to provide a holding charge of oil, as part of the Low Pressure Oil Management System. The amount of oil circulating in a system varies depending on the operating conditions. The oil reservoir caters for these fluctuations by providing additional storage capacity.

Rotalock valves are supplied with each reservoir to facilitate easy oil fill and drain. A connection is provided at the top of the unit for fitting a pressure vent valve. Models are provided with either two or three sight glasses for visual indication of oil level.

Applications

The standard range of reservoirs is suitable for HCFC and HFC refrigerants, along with their associated oils. The SH range, with a higher MWP, is also suitable for sub-critical CO₂ applications.

Main Features

- Three sizes available in both standard and high pressure ranges
- Robust construction
- All models supplied with Rotalock valves
- Sight glass with floating ball
- Double seal on sight glass for leak integrity: thread sealant and O-ring
- Premium quality O-ring seals
- Standard models supplied with mounting brackets
- Mounting brackets available on request for high pressure range

Technical Specification

For standard models:

Allowable operating pressure = 0 to 31 barg

Allowable operating temperature = -10°C to +120°C

For SH models:

Allowable operating pressure = 0 to 45 barg

Allowable operating temperature = -10°C to +110°C

Materials of Construction

The shell, end caps and fitting connections are made from carbon steel.



Selection Guidelines

Both ranges of Henry reservoirs include three different oil holding capacities of approximately 7.5, 11.5 and 15 litres.

The required holding capacity is dependent on a number of system design factors such as oil return piping practice, compressor type, number of compressors, compressor run times, etc.

For single stage parallel systems, a simple selection guide can be used. For other systems, please contact Henry Technologies. The selection guide uses total compressor theoretical displacement, V_h , as an indicator of required oil reservoir capacity.

Example:-

8 compressors each with a theoretical displacement of 17 m³/hr.

Therefore V_h (total) = 136 m³/hr.

The selected model is S-9109-CE, with a V_h rating of up to 150 m³/hr.

Refer to selection table.

Note: It is known that some users select oil reservoir capacity using different rules from the above or from field experience. The method presented above is for guidance purposes only. If in doubt, select a larger capacity reservoir.

Installation – Main issues

1. Full instructions are given in the Product Instruction Sheet, included with each reservoir.

OIL RESERVOIR CAPACITY TABLE

Part No	Reservoir capacity within dimension shown (litres)			
	D	E	F	A
S-9109-CE	2.9	2.8	N/A	7.0
S-9108U-CE	2.9	6.6	N/A	10.8
S-9108-CE	2.9	5.3	5.3	14.7
SH-9109-CE	3.7	2.8	N/A	8.6
SH-9108U-CE	3.7	6.6	N/A	12.5
SH-9108-CE	3.7	5.3	5.3	16.3

Part No	Dimensions (mm)						Drawing reference	Weight (kg)	MWP (barg)	CE Cat
	A	B	C	D	E	F				
S-9109-CE	426	507	152	177	165	N/A	fig.1	9	31	Cat II
S-9108U-CE	654	735	152	177	394	N/A	fig.1	12.5	31	Cat II
S-9108-CE	883	965	152	177	311	311	fig.2	15.5	31	Cat II
SH-9109-CE	522	604	152	225	165	N/A	fig.3	9	45	Cat II
SH-9108U-CE	751	832	152	225	394	N/A	fig.3	12.5	45	Cat II
SH-9108-CE	980	1061	152	225	311	311	fig.4	15.5	45	Cat II

* ODS Rotalock valve connections available on request

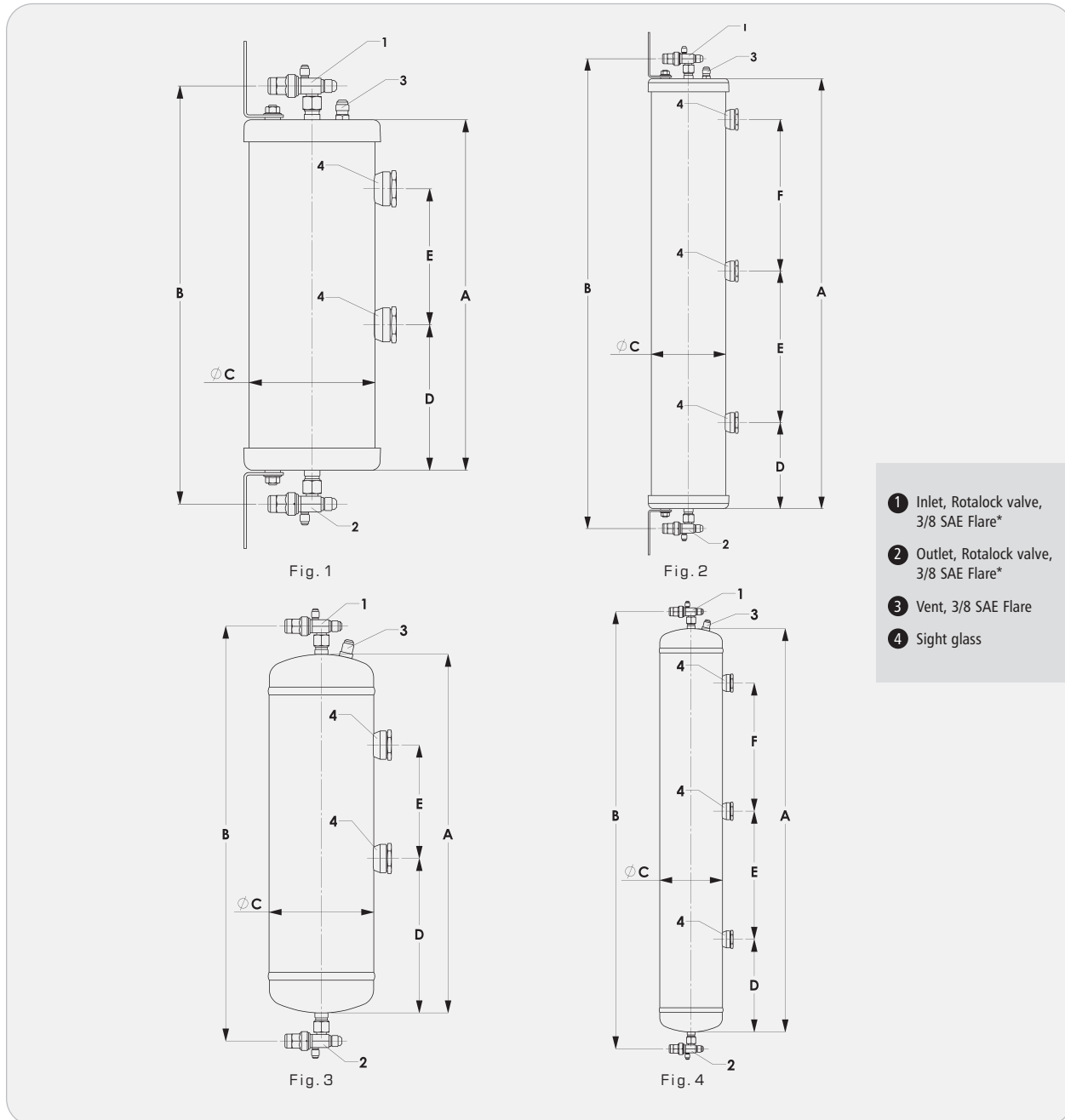

OIL RESERVOIR SELECTION TABLE		
Part No	Capacity (litres)	V _h , total (m ³ /hr)
S-9109-CE	6.9	up to 150
S-9108U-CE	10.7	150-300
S-9108-CE	14.5	300-400
SH-9109-CE	8.2	up to 150
SH-9108U-CE	12.0	150-300
SH-9108-CE	15.8	300-400

Note: V_h = Summation of the theoretical displacment for all compressors in system

RESERVOIR PRESSURE VALVES

The function of a Reservoir Pressure Valve is to control pressure in an oil reservoir.

Applications

A reservoir pressure valve is used in a Low Pressure Oil Management System. It is used to vent pressure in the oil reservoir while still maintaining a positive pressure differential between the reservoir and the compressor crankcase. This positive pressure ensures an adequate oil supply to the oil level regulators. The reservoir pressure valve is piped to suction pressure.

These valves are suitable for use with HCFC, HFC and CO₂ refrigerants, along with their associated oils.

Main Features

- Proven design
- Three different pressure settings
- Premium quality neoprene seal

Technical Specification

Allowable operating pressure = 0 to 45 barg

Allowable operating temperature = -10°C to +120°C

Materials of Construction

The valve body components are made from brass, the spring from stainless steel and the seal from neoprene or PTFE (S-9104XHT).



Part No	Pressure Setting (barg)	Conn Size (inch)		Weight (kg)	CE Cat
		Inlet	Outlet		
S-9104	0.35 fixed	3/8 SAE Flare Female	3/8 SAE Flare Male	0.13	SEP
S-9104H	1.4 fixed	3/8 SAE Flare Female	3/8 SAE Flare Male	0.13	SEP
S-9104XH	2.4 fixed	3/8 SAE Flare Female	3/8 SAE Flare Male	0.13	SEP
S-9104XHT	2.4 fixed	3/8 SAE Flare Female	3/8 SAE Flare Male	0.13	SEP

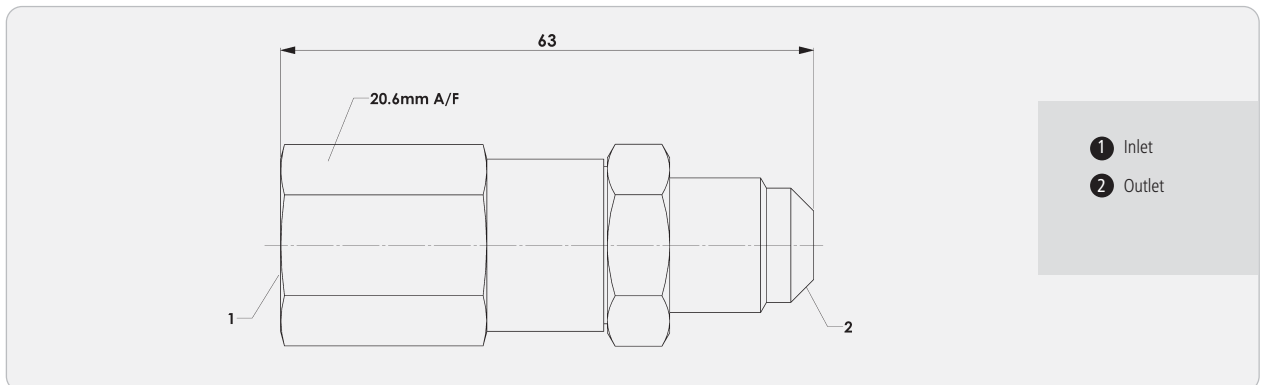

RESERVOIR PRESSURE VALVE

Selection guidelines

The S-9104, S-9104H and S-9104XH models provide 0.35, 1.4 and 2.4 barg pressure differentials respectively.

A higher pressure differential will increase the oil flow rate from the oil reservoir back to the compressors.

The user should select a model taking into account individual compressor crankcase pressures along with the differential pressure range of the oil regulators. If foaming is a concern do not use the S-9104XH model.

OIL REGULATOR SHUT-OFF VALVES

The function of Oil Regulator Shut-off valves is to provide a means for equipment isolation. Horizontal and vertical models are available.

Applications

These valves are positioned on the oil inlet and equalisation pipe lines of Henry Technologies Oil Level Regulators. This allows each oil level regulator to be isolated in the event that servicing is required on the compressor, oil level regulator, strainer, etc.

The valves are suitable for HCFC and HFC refrigerants, along with their associated oils.

Main features

- Two mounting options – horizontal and vertical
- 360° positioning via swivel connection

Technical Specification

Allowable operating pressure = 0 to 45 barg

Allowable operating temperature = -10°C to +100°C

Materials of Construction

The main body and swivel nut are made from brass. The stem is made from plated steel. The stem seal cap is made from moulded plastic.



Part No	Conn Size (inch)		Dimensions (mm)			Type	Weight (kg)	CE Cat
	Fixed	Swivel	A	B	C			
S-9106E	1/4 SAE Flare	1/4 SAE Female Flare	102	37	27	Vertical	0.14	SEP
S-9106H	3/8 SAE Flare	3/8 SAE Female Flare	92	27	39	Horizontal	0.16	SEP
S-9106V	3/8 SAE Flare	3/8 SAE Female Flare	104	39	32	Vertical	0.17	SEP
S-9106EH	1/4 SAE Flare	1/4 SAE Female Flare	92	27	36	Horizontal	0.15	SEP

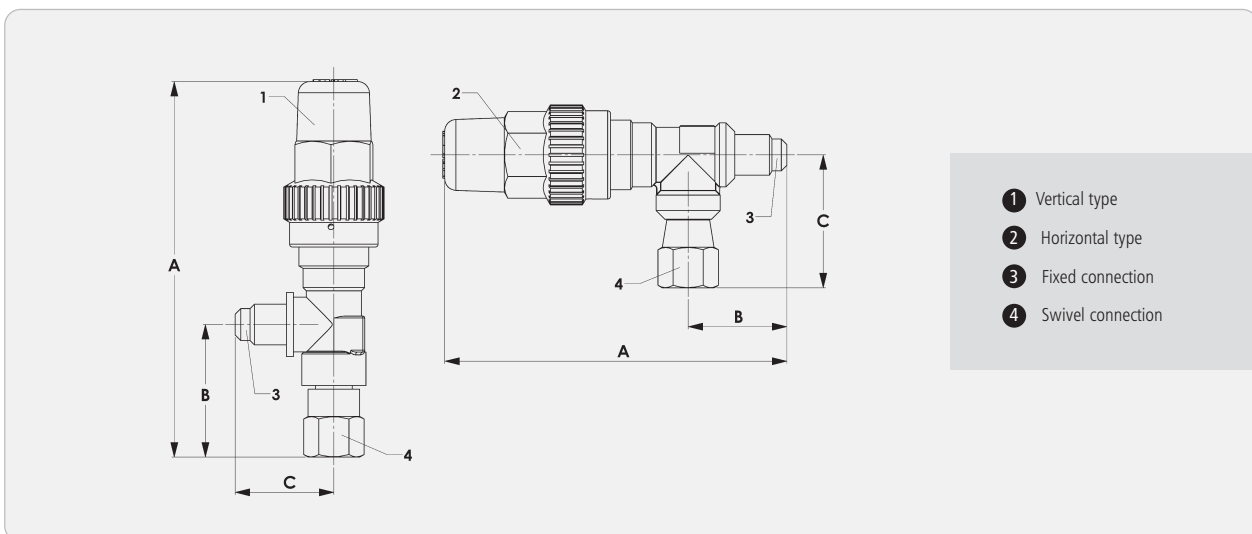

OIL REGULATOR SHUT-OFF VALVES

OIL STRAINERS

The function of an oil strainer is to remove system debris from the refrigerant oil. Their purpose is to protect compressors and oil level regulators from damage.

Applications

The Henry Technologies S-91 and SH-91 series oil strainers can be used in both Low and High Pressure Oil Management Systems. The S-91 series is suitable for HCFC and HFC refrigerants along with their associated oils and the SH-91 series is suitable for HCFC, HFC and CO₂ refrigerants and their associated oils.

Although the strainer is compatible with HFC/POE refrigerant/oil combinations, Henry Technologies recommends the use of an oil filter or oil filter drier. This is due to the scavenging nature of POE oil.

Greater system protection will be achieved using a filter or filter drier element than with a mesh strainer.

Typically, a strainer is fitted immediately upstream of a mechanical oil level regulator in order to protect the float needle valve from debris. This in turn protects the compressor from damage.

Main features

- Large screen area ensuring maximum capacity and long service
- Low pressure drop
- Stainless steel screen
- SAE or ODS connections available

Technical Specification

S-91 Series

Allowable operating temperature = -10°C to +120°C

Allowable operating pressure = 0 to 34.5 barg

Screen = 100 mesh, 71cm² filter area.

SH-91 Series

Allowable operating temperature = 0°C to +100°C

Allowable operating pressure = 0 to 45 barg

Screen = 200 mesh, 91cm² filter area.



Materials of Construction

The main body and connections are made from carbon steel. The mesh screen is made from stainless steel.

Main features

1. The oil strainer must be installed in accordance with the flow direction arrow.
2. It is recommended to install valves on either side of the unit to ease replacement, in the event that the mesh screen becomes blocked.

Part No	Conn Size (inch)		Dimensions (mm)		Screen Data		Weight (kg)	CE Cat
	Inlet	Outlet	A	Ø B	Area (mm ²)	Mesh		
S-9105	3/8 SAE Flare	3/8 SAE Flare	129	51	7095	100	0.37	SEP
S-9105X	3/8 ODS	3/8 ODS	103	51	7095	100	0.33	SEP
SH-9105	3/8 SAE Flare	3/8 SAE Flare	153	66	9100	200	0.37	SEP
SH-9105X	3/8 ODS	3/8 ODS	146	66	9100	200	0.32	SEP

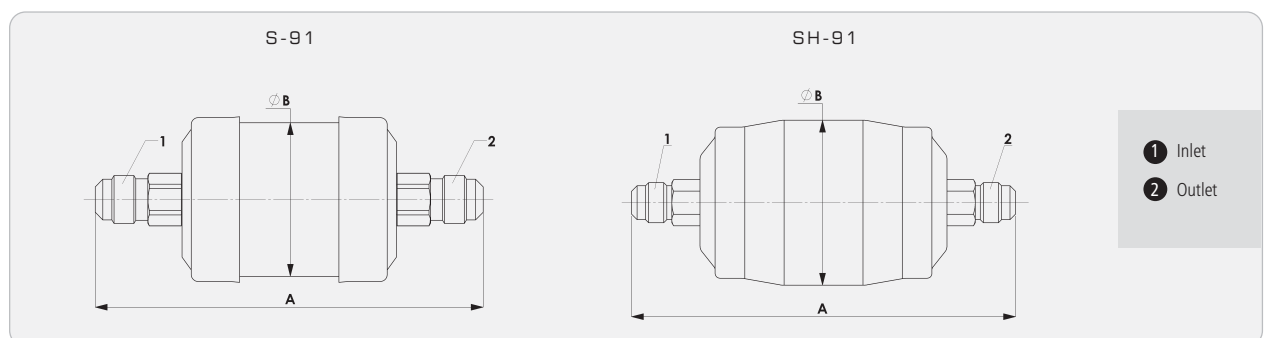

OIL FILTERS AND OIL FILTER DRIERS

The function of an Oil Filter is to remove system debris from the refrigerant oil. The function of an Oil Filter Drier is to remove both system debris and moisture from the refrigerant oil. Their purpose is to protect compressors and oil level regulators from damage.

Applications

The Henry Technologies S-4004 oil filter and S-4005 oil filter drier can be used in both Low and High Pressure Oil Management Systems.

Models are suitable for HCFC and HFC refrigerants along with their associated oils.

The unique drying features of the S-4005 model are particularly suited for systems using POE oil. This type of oil is more hydroscopic than mineral oil. This means that POE oil absorbs moisture at a much higher rate. Moisture in a refrigeration system can produce problems and/or harmful conditions.

One S-4004 or S-4005 model can be fitted in the oil return line between the oil separator and oil reservoir, instead of fitting one oil strainer per oil level regulator. These models will also remove more debris than traditional oil strainers.

Main Features

S-4004 model

- High flow capacity with low pressure drop
- Large filter area
- Micronic filtration
- Eliminates the need to fit individual oil return line strainers

S-4005 and SH-4005 models

- High flow capacity with low pressure drop
- Large filter area
- Micronic filtration
- High level of drying
- Eliminates the need to fit individual oil return line strainers

Technical Specification

S-4004 model

Allowable operating pressure = 0 to 31 barg

Allowable operating temperature = -10°C to +100°C

Filter surface area = 3065 cm²

Filter particle retention = 10 micron

S-4005 model

Allowable operating pressure = 0 to 31 barg

Allowable operating temperature = -10°C to +100°C

Filter surface area = 3000 cm²

Filter particle retention = 6 micron

Drier = 131cm³ of XH9 desiccant

SH-4005 model

Same as S-4005, except

Allowable operating pressure = 0 to 60 barg



Installation – Main issues

1. The oil filter or filter drier must be installed in accordance with the flow direction arrow.
2. Units should be replaced after a 1 barg (15 psig) pressure drop has been detected. Pressure drop can be detected by fitting Schrader valves before and after the unit. It is recommended to install valves on either side of the unit to ease replacement, in the event that the filter becomes blocked.
3. For low pressure oil management systems, oil filters and filter driers should be located between the oil separator and oil reservoir, not between the oil reservoir and the oil regulator.

Part No	Conn Size (inch)		Dimensions (mm)		Weight (kg)	MWP (barg)	CE Cat
	Inlet	Outlet	A	Ø B			
S-4004	3/8 SAE Flare	3/8 SAE Flare	188	102	1.93	31	SEP

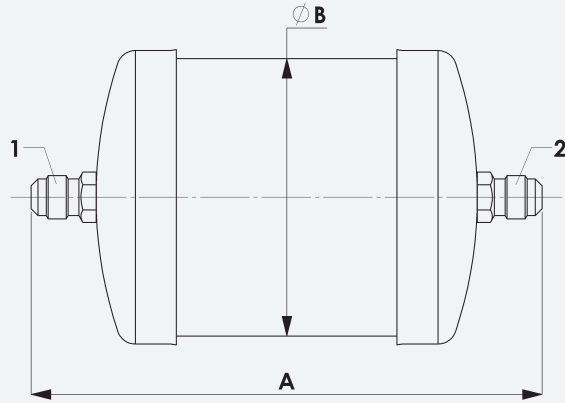

S-4004 OIL FILTER

- 1 Inlet
- 2 Outlet
- 3 Schrader valve (S-4005 model only)

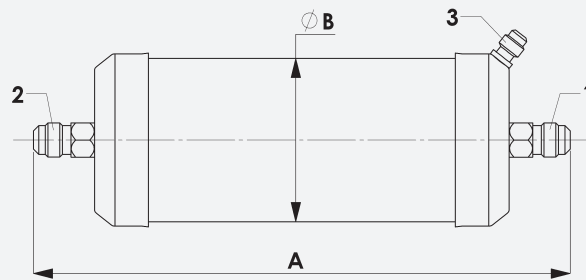

S-4005/SH-4005 OIL FILTER DRIER

Part No	Conn Size (inch)		Dimensions (mm)		Weight (kg)	MWP (barg)	CE Cat
	Inlet	Outlet	A	Ø B			
S-4005	3/8 SAE Flare	3/8 SAE Flare	251	76	1.55	31	SEP
SH-4005	3/8 SAE Flare	3/8 SAE Flare	251	76	1.55	60	SEP

LIQUID LEVEL SWITCHES



The function of a Liquid Level Switch is detect and monitor liquid levels.

Applications

The level switch can be installed in a number of locations in the refrigeration system such as liquid receivers, suction line accumulators and compressor crankcases.

The range is designed for use with HCFC, HFC and ammonia refrigerants, along with their associated oils. A 1" NPT level switch is recommended for ammonia applications. For other refrigerant/oil combinations, please contact Henry Technologies.

How it works

The S-94 series electronic level switches use infrared light reflecting from a conical glass prism as a means of detecting the absence of fluid at the level of the glass cone. An integral part of the switch is an infrared module, containing a light emitter and receiver.

When no fluid covers the lower half of the cone, infrared light from the emitter reflects from the inner surface of the cone back to the receiver. This signals the module to switch. When fluid covers the lower half of the cone, the light from the emitter disperses into the fluid. The resulting absence of reflected light is detected by the receiver and the module switches in the opposite direction.

Main Features

- Patented optical sensor technology#
- Robust design
- Serviceable without refrigerant loss
- No moving parts
- Fused glass hermetic seal
- Flying leads and DIN connector options

US patent 5278426

Technical Specification

Allowable operating pressure:	0 to 46 barg*
Allowable operating temperature:	-40°C to +99°C
Mounting:	Horizontal only
Supply voltage:	Refer to table
Switch inductive rating:	36VA pilot duty rated
Contact life:	Over 1 million cycles at rated electrical load
Power for operation:	3.5mA AC, 5.5mA DC
Minimum load:	2mA (without bleed resistor)
Resistive rating:	Refer to table
Contacts, power off:	Normally Open (NO)
Contacts, power on: (liquid present)	Refer to table
Customer interface:	Refer to table
Protection class:	IP 65 DIN models only

*Higher pressures of up to 130 barg available on request.

Materials of Construction

The switch consists of a plated steel body with a built-in fused glass prism.

** Part No	Voltage	Resistive rating	Contacts - power on & liquid present	Customer interface	Wire colour codes	Drawing reference	Dimensions			Replacement Module/kit number	Weight (kg)	CE Cat
							A (mounting thread)	B across flats (mm)	C (mm)			
S-9400	120V 50/60 HZ	0.5 A	closed	flying leads	Yellow & White	fig.1	1/2" NPT	28.6	192	2-044-012	0.22	SEP
S-9420	208/240V 50/60 HZ	0.25A	closed	flying leads	Red & White	fig.1	1/2" NPT	31.8	192	A4416	0.22	SEP
S-9420A	208/240V 50/60 HZ	0.25A	open	flying leads	Red & White/Stripe	fig.1	1/2" NPT	31.8	192	A4415	0.22	SEP
S-9424	24V AC/DC	0.5A	closed	flying leads	Orange & White	fig.1	1/2" NPT	31.8	192	A4414	0.22	SEP
S-9424A	24V AC/DC	0.5A	open	flying leads	Orange & White/Stripe	fig.1	1/2" NPT	31.8	192	2-044-020	0.22	SEP

**A 1" NPT connection is available for the S-9400 series by ordering with a "-1" suffix (i.e. S-9424-1)
 Note: load is to be wired between black and coloured leads.

Note: The optional 1" NPT level switches allow the unit to be mounted closer to the inner wall of the vessel. This eliminates the potential for a pool of liquid next to the glass prism, which can be detrimental to performance. A 1" NPT level switch is recommended for ammonia applications where residue can build up on the glass prism.

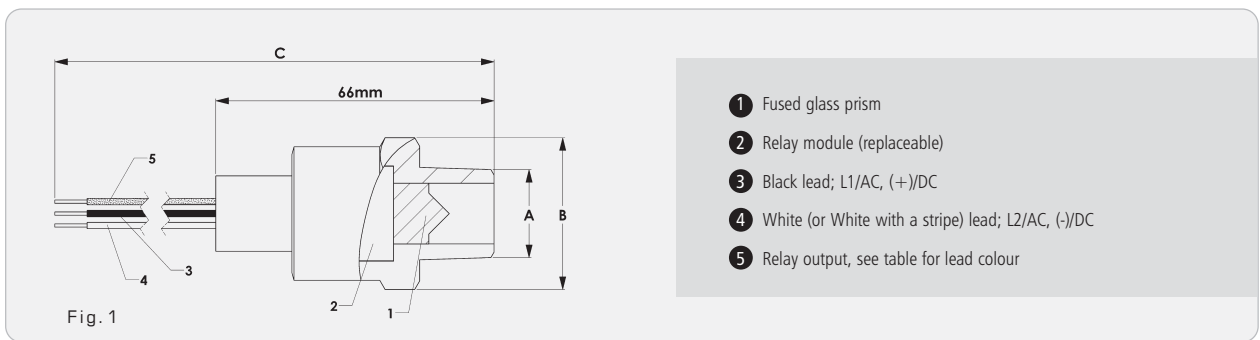

- 1 Fused glass prism
- 2 Relay module (replaceable)
- 3 Black lead; L1/AC, (+)/DC
- 4 White (or White with a stripe) lead; L2/AC, (-)/DC
- 5 Relay output, see table for lead colour

Part No	Voltage	Resistive rating	Contacts - power on & liquid present	Customer interface	Wire colour codes	Drawing reference	Replacement Module number	Weight (kg)	CE Cat
S-9420DN	208/240V 50/60 HZ	0.25 A	closed	DIN socket	Red & White	fig.2	A4416	0.23	SEP
S-9424DN	24V AC/DC	0.5 A	closed	DIN socket	Orange & White	fig.2	A4414	0.23	SEP
S-9424-3/4UK	24V AC/DC	0.5A	closed	DIN plug	Orange & White	fig.3	A4414	0.23	SEP

NOTE: load is to be wired between black and coloured leads.

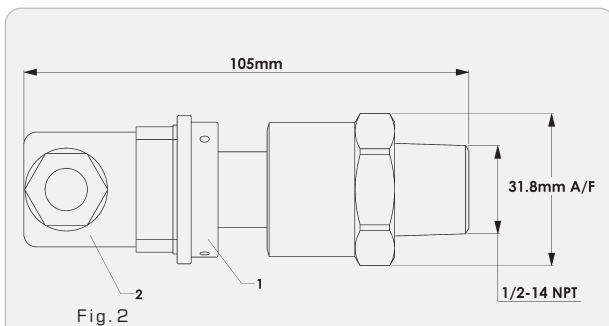

- 1 Adaptor
- 2 Socket connector

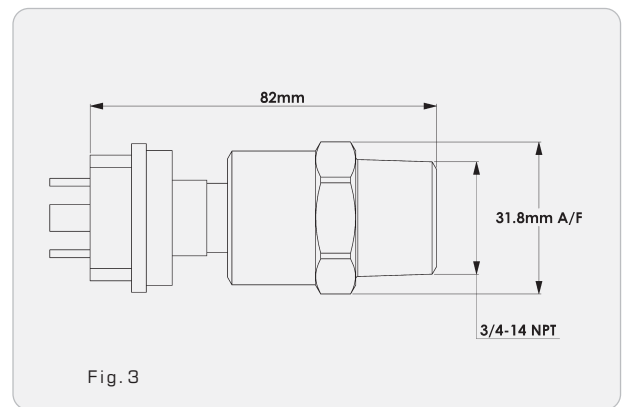

Installation – Main issues

1. Install a level switch horizontally. If the unit is mounted at an angle or vertically, liquid can be trapped which will cause switching problems.
2. Ensure that no object is within 50 mm of the glass prism.
3. Wiring diagrams are included in the Product Instruction sheets.
4. The switches should not be used with very dirty liquids.
5. Full instructions are given in the Product Instruction sheet, provided with each unit.

VALVE MANIFOLDS



The function of a valve manifold is to simplify pipework, reduce the number of fittings and provide a means to isolate equipment during service.

Applications

The valve manifold is designed for use with HCFC and HFC refrigerants along with their associated oils.

The manifold can be used on both oil and liquid refrigerant lines.

Main Features

- Fully assembled and tested – reduces customer assembly time
- Easy installation via flare connections
- Fewer mechanical joints
- Flexible configuration - 3 to 8 valve ports available
- Robust steel body

Technical Specification

Allowable operating pressure = 0 to 27.5 barg

Allowable operating temperature = -10°C to +100°C

Materials of Construction

The manifold tube, valve bodies and valve stems are made from carbon steel, brass and plated carbon steel respectively. The valve seal caps are made from moulded plastic.

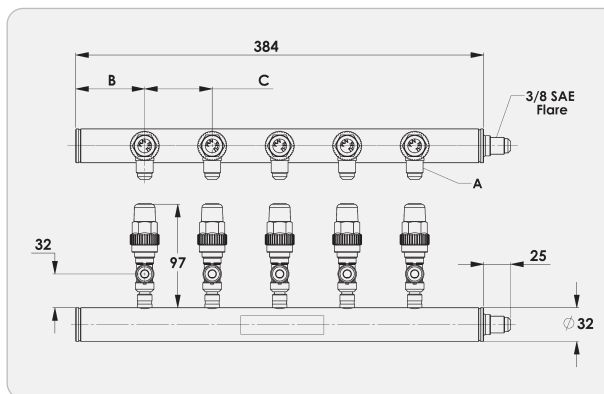

VALVE MANIFOLD

Part No	No of Valves	A SAE Flare	B (mm)	C pitch (mm)	Weight (kg)	CE Cat
FP003-1/4	3	1/4 Flare	65	127	1.15	SEP
FP003-3/8	3	3/8 Flare	65	127	1.15	SEP
FP004-1/4	4	1/4 Flare	52	80	1.28	SEP
FP004-3/8	4	3/8 Flare	52	80	1.28	SEP
FP005-1/4	5	1/4 Flare	65	63.5	1.40	SEP
FP005-3/8	5	3/8 Flare	65	63.5	1.40	SEP
FP006-1/4	6	1/4 Flare	92	40	1.53	SEP
FP006-3/8	6	3/8 Flare	92	40	1.53	SEP
FP008-1/4	8	1/4 Flare	52	40	1.77	SEP
FP008-3/8	8	3/8 Flare	52	40	1.77	SEP

SUCTION LINE ACCUMULATORS

The primary function of a Suction Line Accumulator is to prevent a sudden surge of liquid refrigerant, or oil, from returning down the suction line and into a compressor. The suction line accumulator is a temporary reservoir for liquid refrigerant and oil.

The accumulator is designed to meter both the liquid refrigerant and oil back to the compressor at a controlled rate. This prevents compressor damage. By metering the liquid refrigerant and oil back to the compressor, the accumulator also helps maintain system efficiency and proper crankcase oil levels. Both horizontal and vertical suction line accumulators are available. Heat Exchanger (HE) and Heat Pump models (HP) are also available.

Applications

Suction line accumulators are installed in air conditioning and refrigeration systems where a sudden return of liquid down the suction line is possible. The product range is designed for use with HCFC and HFC refrigerants, along with their associated oils.

How it works

Refrigerant vapour from the evaporator enters the suction line accumulator, along with any liquid refrigerant or oil. The outlet side of each accumulator is designed to allow refrigerant vapour to return to the compressor. For a horizontal vessel, the position of the outlet connection ensures vapour return. For a vertical vessel, vapour return is achieved by a special U tube arrangement. On certain models, a tube within a tube arrangement is used as an alternative. Liquid is held at the bottom of the accumulator ready for metering back to the compressor.

For horizontal accumulators, liquid is metered to the compressor via a dip tube. For vertical models, liquid is metered to the compressor via a screened orifice at the bottom of the tube. The vapour carries the metered liquid back to the compressor. Metering of liquid only occurs when the compressor is running.

Main features

- Prevents liquid slugging
- Controlled liquid return
- Large flow capacity
- Low pressure drop
- Screen protected orifice on vertical models
- Heat exchanger and Heat pump options

Technical Specification

S-76 series:

MWP = 20.8 barg @ +80°C

S-704, S-705, S-706, S-772 & S-773 series:

MWP = 31 barg @ +80°C

S-7741 & S-7742 series:

MWP = 27.6 barg @ +80°C

Note: For all models, a de-rated MWP applies for operating temperatures below -10°C. For further information, please contact Henry Technologies.

Materials of Construction

The shell and end caps are made from carbon steel. Branch connections are made from steel or copper.



SUCTION LINE ACCUMULATORS

Part No	Conn Size (inch)	Dimensions (mm)						Mounting Details	Weight (kg)	CE Cat
		Ø A	B	C	D	E	F			
S-7615-CE	1 5/8 ODS	152	711	546	99	774	825	4 x Ø 12.7mm Slots	13	Cat II
S-7621-CE	2 1/8 ODS	152	933	768	100	996	1047	4 x Ø 12.7mm Slots	16	Cat II
S-7625-CE	2 5/8 ODS	152	1270	1105	105	1333	1384	4 x Ø 12.7mm Slots	21	Cat II

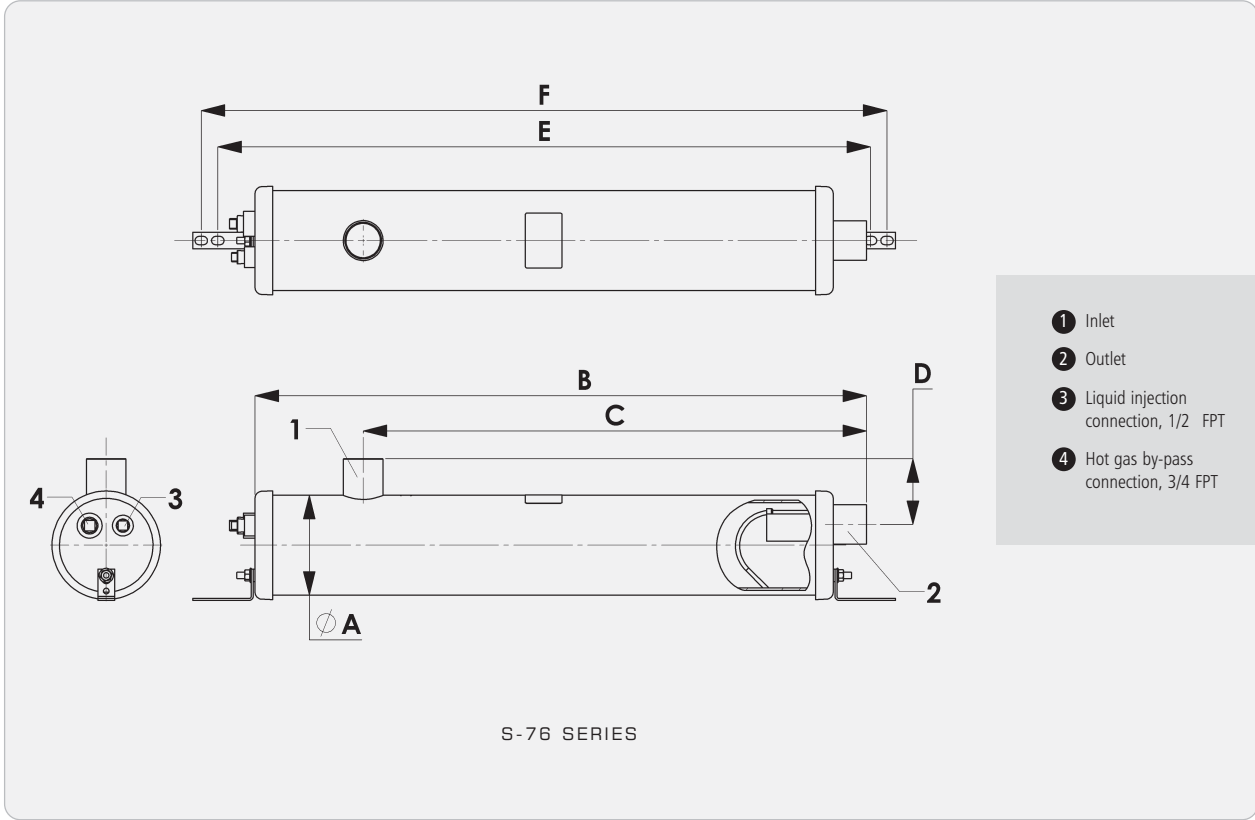

Part No	Conn Size (inch)		Dimensions (mm)					Mounting details	HE Coil Conn Size (inch)	Drawing Reference	Weight (kg)	CE Cat	
			A	B	C	D	E (Ø)						
S-7043	-	-	5/8 ODS	102	168	48	N/A	N/A	M10 stud & nut	N/A	fig.1	2	SEP
S-7044	-	S-7044-HP	1/2 ODS	102	264	48	N/A	N/A	M10 stud & nut	N/A	fig.1	2.5	SEP
S-7045	-	S-7045HP	5/8 ODS	102	264	48	N/A	N/A	M10 stud & nut	N/A	fig.1	2.5	SEP
-	S-7045HE	-	5/8 ODS	102	264	64	64	N/A	M10 stud & nut	3/8 ODS	fig.1	2.5	SEP
S-7046	-	S-7046HP	3/4 ODS	102	270	48	N/A	N/A	M10 stud & nut	N/A	fig.1	2.5	SEP
-	S-7046HE	-	3/4 ODS	102	270	64	64	N/A	M10 stud & nut	3/8 ODS	fig.1	2.5	SEP
S-7057-CE	S-7057HE-CE	S-7057HP-CE	7/8 ODS	152	252	57	70	N/A	M10 stud & nut	1/2 ODS	fig.1	6, 7 (HE)	Cat I
S-7061-CE	S-7061HE-CE	S-7061HP-CE	1 1/8 ODS	152	382	76	73	N/A	M10 stud & nut	5/8 ODS	fig.1	8, 9 (HE)	Cat I
S-7063-CE	S-7063HE-CE	S-7063HP-CE	1 3/8 ODS	152	629	76	73	N/A	M10 stud & nut	5/8 ODS	fig.1	11.5, 13.5 (HE)	Cat II
S-7065-CE	S-7065HE-CE	S-7065HP-CE	1 5/8 ODS	152	639	76	73	N/A	M10 stud & nut	3/4 ODS	fig.1	11.5, 13.5 (HE)	Cat II
S-7721-CE	-	-	2 1/8 ODS	219	588	89	140	282	3 Ø14mm x 22mm slots	N/A	fig.2	23	Cat II
-	S-7721HE-CE	-	2 1/8 ODS	219	588	89	140	282	3 Ø14mm x 22mm slots	7/8 ODS	fig.3	27	Cat II
S-7722-CE	-	-	2 1/8 ODS	219	588	89	140	282	3 Ø14mm x 22mm slots	N/A	fig.2	23	Cat II
-	S-7722HE-CE	-	2 1/8 ODS	219	588	89	140	282	3 Ø14mm x 22mm slots	7/8 ODS	fig.3	27	Cat II
S-7725-CE	-	-	2 5/8 ODS	273	578	118	140	337.4	3 Ø14mm x 22mm slots	N/A	fig.2	33.5	Cat II
-	S-7725HE-CE	-	2 5/8 ODS	273	578	118	140	337.4	3 Ø14mm x 22mm slots	1 3/8 ODS	fig.3	39.5	Cat II
S-7726-CE	-	-	2 5/8 ODS	273	578	118	140	337.4	3 Ø14mm x 22mm slots	N/A	fig.2	33.5	Cat II
-	S-7726HE-CE	-	2 5/8 ODS	273	578	118	140	337.4	3 Ø14mm x 22mm slots	1 3/8 ODS	fig.3	39.5	Cat II
S-7731-CE	-	-	3 1/8 ODS	324	635	140	149	388.4	3 Ø14mm x 22mm slots	N/A	fig.2	47	Cat IV
-	S-7731HE-CE	-	3 1/8 ODS	324	635	140	149	388.4	3 Ø14mm x 22mm slots	1 3/8 ODS	fig.3	52	Cat IV
S-7732-CE	-	-	3 1/8 ODS	324	635	140	149	388.4	3 Ø14mm x 22mm slots	N/A	fig.2	47	Cat IV
-	S-7732HE-CE	-	3 1/8 ODS	324	635	140	149	388.4	3 Ø14mm x 22mm slots	1 3/8 ODS	fig.3	52	Cat IV
S-7741-CE	S-7741HE-CE	-	4 1/8 ODS	406	902	279	368	470	3 Ø14mm x 22mm slots	2 5/8 ODS	fig.4	102	Cat III
S-7742-CE*	-	-	4 1/8 ODS	508	1130	330	N/A	457	4 x Ø16.3mm holes on square base	N/A	fig.4*	130	Cat IV

*S-7742-CE features a square mounting plate - not mounting brackets

Notes (to be read in conjunction with drawing legend):-
 For liquid level switch and relief valve connection positions, see notes below for relevant models
 1. S-7722, S-7722HE & S-7726 models
 2. S-7726HE, S-7732, S-7732HE, S-7741, S-7741HE & S-7742 models
 3. S-7741HE model
 4. S-7741 & S-7742 models

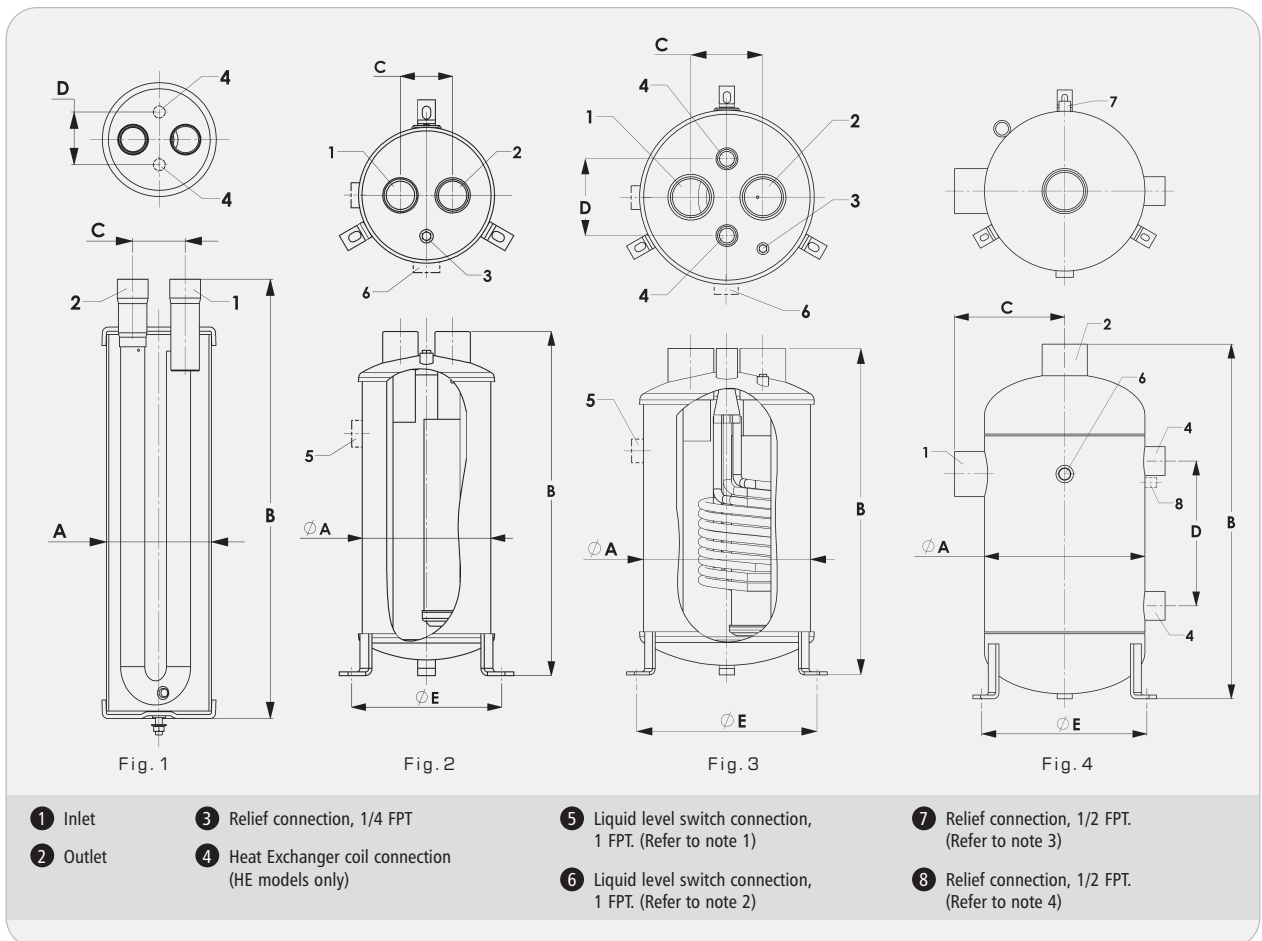

SUCTION LINE ACCUMULATORS

Part No	Refrigerant Holding Capacity (kg at -18°C)			Recommended kW of refrigerant at Suction Evaporating Temp (°C)																															
	R134a	R407F	R404A	R134a					R407F					R404A / R507																					
				5°	-7°	-18°	-29°	-40°	5°	-7°	-18°	-29°	-40°	5°	-7°	-18°	-29°	-40°																	
S-7615-CE	10.6	9.7	8.8	MAX	53	35	Horizontal accumulators not suitable for applications below -10°C					145	98	Horizontal accumulators not suitable for applications below -10°C					100	57	Horizontal accumulators not suitable for applications below -10°C														
S-7621-CE	14.4	13	11.9	MAX	101	69	Horizontal accumulators not suitable for applications below -10°C					254	170	Horizontal accumulators not suitable for applications below -10°C					173	117	Horizontal accumulators not suitable for applications below -10°C														
S-7625-CE	21.2	19	17.6	MAX	176	123	Horizontal accumulators not suitable for applications below -10°C					481	323	Horizontal accumulators not suitable for applications below -10°C					328	217	Horizontal accumulators not suitable for applications below -10°C														
S-7043	1	0.9	0.7	MAX	3.2	2.3	1.5	1	0.6	10.5	7.1	4.7	2.9	1.7	6.3	4.3	2.8	1.8	1.1	MIN	0.7	0.6	0.5	0.4	0.3	2.4	1.6	1.1	0.7	0.4	0.9	0.7	0.6	0.5	0.4
S-7044	2	1.9	1.7	MAX	1.6	1.2	0.8	0.5	0.6	5.8	3.9	2.6	1.6	1	3.1	2.2	1.5	0.9	MIN	0.3	0.2	0.2	0.2	0.1	1.7	1.1	0.7	0.5	0.3	0.5	0.3	0.3	0.2	0.2	
S-7045	2	1.9	1.7	MAX	3.2	2.3	1.5	1	0.6	10.5	7.1	4.7	2.9	1.7	6.3	4.3	2.8	1.8	MIN	0.7	0.6	0.5	0.4	0.3	2.4	1.6	1	0.7	0.4	0.9	0.7	0.6	0.5	0.4	
S-7046	2	1.9	1.7	MAX	4.5	3.1	2.1	1.4	0.8	14.4	9.7	6.4	4	2.4	8.7	5.9	3.8	2.5	MIN	0.9	0.7	0.6	0.5	0.4	3.2	2.2	1.4	0.9	0.5	1.3	1	0.8	0.6	0.5	
S-7057-CE	4.2	3.8	3.5	MAX	7.7	5.4	3.6	2.3	1.4	24.2	16.3	10.7	6.7	4	14.9	10.2	6.5	4.2	MIN	1.3	1.1	0.9	0.7	0.6	4.9	3.3	2.2	1.4	0.8	1.8	1.5	1.2	1	0.7	
S-7061-CE	5.8	5.5	4.9	MAX	16.3	11.4	7.3	4.8	2.9	49.8	33.4	22.1	13.8	8.2	31.4	21.7	13.2	8.6	MIN	16.3	11.4	7.3	4.8	2.9	49.8	33.4	22.1	13.8	8.2	31.4	21.7	13.2	8.6	5.2	
S-7063-CE	9.9	9	8.3	MAX	27.8	18.8	12	7.6	4.7	82.1	55.1	36.4	22.8	13.4	53.9	35.9	21.8	13.8	MIN	27.8	18.8	12	7.6	4.7	82.1	55.1	36.4	22.8	13.4	53.9	35.9	21.8	13.8	8.6	
S-7065-CE	9.9	9	8.3	MAX	49.3	33.8	21.1	13.4	8.2	145	97.4	64.4	40.2	23.7	95	64.1	38	24.3	MIN	49.3	33.8	21.1	13.4	8.2	145	97.4	64.4	40.2	23.7	95	64.1	38	24.3	15	
S-7065-CE	9.9	9	8.3	MAX	7.6	6.3	5.3	4.4	3.5	28.7	19.3	12.7	8	4.7	10.3	8.4	7	5.7	MIN	7.6	6.3	5.3	4.4	3.5	28.7	19.3	12.7	8	4.7	10.3	8.4	7	5.7	4.4	
S-7721-CE	14.7	13.4	12.3	MAX	109	70.4	49.3	26.4	17.6	322	216	143	89.2	52.7	201	134	84.5	56.3	MIN	109	70.4	49.3	26.4	17.6	322	216	143	89.2	52.7	201	134	84.5	56.3	35.2	
S-7722-CE	14.7	13.4	12.3	MAX	109	70.4	49.3	26.4	17.6	322	216	143	89.2	52.7	201	134	84.5	56.3	MIN	14.1	12.3	10.6	8.8	7	57.4	38.5	25.5	15.9	9.4	21.1	17.6	14.1	12.3	8.8	
S-7725-CE	22	19.9	18.2	MAX	172	113	75.7	42.2	22.9	480	322	213	133	78.6	308	204	132	88	MIN	172	113	75.7	42.2	22.9	480	322	213	133	78.6	308	204	132	88	47.5	
S-7726-CE	22	19.9	18.2	MAX	21.1	19.4	15.8	12.3	3.5	95.9	64.4	42.6	26.6	15.7	31.7	28.2	22.9	21.1	MIN	21.1	19.4	15.8	12.3	3.5	95.9	64.4	42.6	26.6	15.7	31.7	28.2	22.9	21.1	5.3	
S-7731-CE	36.4	32.9	30	MAX	253	194	130	84.5	33.4	712	478	316	197	117	456	308	197	125	MIN	253	194	130	84.5	33.4	712	478	316	197	117	456	308	197	125	70.4	
S-7732-CE	36.4	32.9	30	MAX	35.2	31.7	24.6	22.9	5.3	143	96	63.4	39.6	23.4	52.8	44	37	29.9	MIN	35.2	31.7	24.6	22.9	5.3	143	96	63.4	39.6	23.4	52.8	44	37	29.9	8.8	
S-7741-CE	62	58.8	55	MAX	401	259	156	107	69.7	1120	752	497	310	183	757	503	320	201	MIN	401	259	156	107	69.7	1120	752	497	310	183	757	503	320	201	116	
S-7742-CE	127	121	114	MAX	109	89.4	75.7	59.8	47.2	362	243	160	100	59.2	174	113	73.9	45.8	MIN	109	89.4	75.7	59.8	47.2	362	243	160	100	59.2	174	113	73.9	45.8	24.6	

Selection Guidelines

The accumulator should have adequate holding capacity. Normally, this should not be less than 50% of the total system charge.

The system designer should check that the minimum and maximum system refrigeration capacities are within the limits of the accumulator.

The recommended minimum and maximum kW capacities are listed in the table. The maximum kW capacities are based on accumulator pressure loss and oil return. The pressure loss is equivalent to 1/2°C. The minimum kW capacities are to ensure proper oil return.

Example:

Refrigerant R404A

System maximum refrigeration capacity = 170 kW

System minimum refrigeration capacity = 65 kW

Evaporating temperature = -18°C

System Charge = 55 kg

Recommended accumulator is model S-7731-CE with a refrigerant holding capacity of 30 kg and a minimum/maximum rating of 37/197 kW.

Additional selection information

The heat exchanger models can be used on low temperature systems to sub-cool the liquid line while helping to boil off liquid refrigerant in the accumulator by passing the liquid line through the heat exchanger coil. This can increase system efficiency while helping oil flow in the suction line. Do not use discharge gas through the heat exchange coil as there is a risk of overheating the compressors.

Heat pump systems must use the HP accumulator models. Winter heating can cause too much liquid refrigerant to slug back to the compressor. Heat pump accumulators incorporate a smaller orifice to prevent excessive liquid flow.

Two accumulators can be piped in series to increase holding capacity. Oil will be metered from one accumulator to the next to ensure proper oil flow to the compressors. Adding a second identical accumulator will effectively double the holding capacity of a single accumulator.

Piping two identical accumulators in parallel will double the kW capacity. Two identical accumulators must be used.

On low temperature systems (-18°C and below) a heater band should be installed to help boil off the liquid refrigerant and aid oil flow. Do not add too much heat or there is a risk of overheating the compressors.

Horizontal accumulators should not be used when the liquid refrigerant temperature is less than -10°C.

Installation – Main issues

1. Install the accumulator after the suction line filter.
2. A pressure relief device connection is provided at the top of the vessel. The user must ensure that the vessel is protected from over-pressure. Over-pressure will occur if the liquid refrigerant is evaporated e.g. external fire case.
3. Heater bands should be installed at the bottom of a vertical accumulator and at the outlet end of a horizontal accumulator.

DISCHARGE LINE MUFFLERS

The function of a Discharge Line Muffler is to reduce noise in the discharge line of a refrigeration or air-conditioning system

Applications

The muffler is designed to be installed directly after the compressor. The product range is designed for use with HCFC and HFC refrigerants, along with their associated oils.

How it works

The muffler reduces noise, due to gas pulsations, by allowing the gas to expand inside muffler chambers. Mufflers have internal baffles which are designed to dampen and smooth out low and high frequency compressor gas sound waves.

Main Features

- Robust design
- Bi-directional flow

Technical Specification

Allowable operating pressure = 0 to 31 barg

Allowable operating temperature = -10°C to + 130°C (S-6404, S-6406, S-6621, S-6625 & S-6631)

Allowable operating temperature = -15°C to + 120°C (S-6304, S-6305, S-6307, S-6311, S-6405, S-6407, S-6411, S-6413, S-6415 & S-6415M)

Materials of Construction

The main body and internal baffles are made from carbon steel. The connections are made from plated carbon steel.



Part No	ODS (inch)	Dimensions (mm)			Weight (kg)	CE Cat
		Ø A	B	C		
S-6304	1/2	76	197	19	1.5	SEP
S-6305	5/8	76	197	19	1.5	SEP
S-6307	7/8	76	246	11	1.3	SEP
S-6311	1 1/8	76	246	11	1.5	SEP
S-6404	1/2	102	171	24	1.5	SEP
S-6405	5/8	102	171	24	1.5	SEP
S-6406	3/4	102	178	24	1.5	SEP
S-6407	7/8	102	178	24	1.5	SEP
S-6411-CE	1 1/8	102	324	24	2.5	Cat I
S-6413-CE	1 3/8	102	349	24	2.5	Cat I
S-6415-CE	1 5/8	102	464	19	3.5	Cat I
S-6415M-CE	42mm	102	464	19	3.5	Cat I
S-6621-CE	2 1/8	152	533	32	9.0	Cat II
S-6625-CE	2 5/8	152	533	25	9.0	Cat II
S-6631-CE	3 1/8	152	568	19	10.0	Cat II

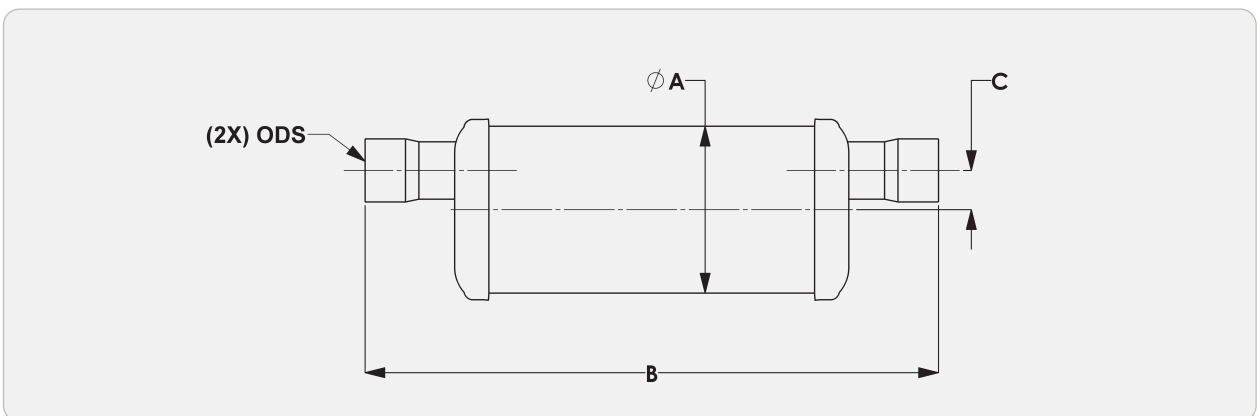

DISCHARGE LINE MUFFLER

DISCHARGE LINE MUFFLERS

Selection Guidelines

Select a muffler with a connection size that matches or exceeds the discharge line size. Larger mufflers will tend to remove more pulsations due to the larger internal volume.

Installation – main issues

1. Install the muffler as close as possible to the compressor and before the oil separator.
2. When mounted in a horizontal or angled position, the side with the label must be top centre to help prevent oil collection inside the muffler. Oil inside the muffler will reduce the performance along with causing a loss of oil in the compressor crankcase. Positioning the muffler at a slight angle so that the outlet port is below the inlet will also help prevent oil collection. Mufflers that are mounted vertically will not collect oil.
3. A vibration eliminator should be installed between the compressor and the muffler to prevent transmitted vibration. The muffler should be supported at each side to prevent discharge pipe vibration, due to the weight of the muffler.
4. Mufflers will only remove noise due to discharge gas pulsations. If the noise is due to vibration, vibration eliminators should be added to the discharge line and possibly the suction line.
5. A single muffler may be installed on a common discharge line. However, some customers prefer to install one muffler per compressor on parallel racks.

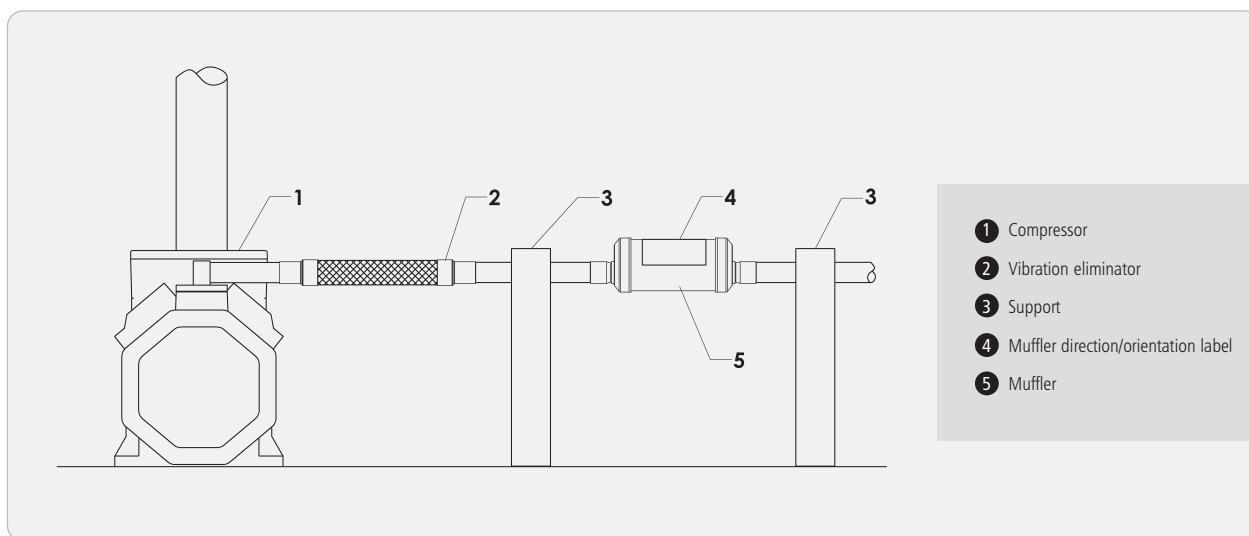

CORRECT MUFFLER SUPPORT

VIBRATION ELIMINATORS



V SERIES

The function of a Vibration Eliminator is to absorb compressor vibration. By installing a vibration eliminator, the risk of damage to system equipment and pipework is reduced.

Applications

A vibration eliminator can be installed in both the suction and discharge lines of air-conditioning and refrigeration systems.

Vibration eliminators are suitable for HCFC, HFC and CO₂ refrigerants, along with their associated oils.

Main Features

- Proven design
- Large hose ID
- Stainless steel hose and braid
- Stainless steel ferrules for superior strength
- Helium leak tested
- CE marked
- UL listed (V series only)

Technical Specification

Allowable operating pressure = As per table

Allowable operating temperature = -40°C to +120°C (V & VS models)

VS SERIES

The V Series

Each unit is constructed of a deep pitch corrugated hose covered with a stainless steel braid. The hose and braid are reinforced by ferrules at each end and connected to copper tube ends by a high temperature braze alloy.

The VS Series

The VS series is based on the proven design of the V series with a few modifications. The VS series is constructed entirely of stainless steel and all joints are tig welded. Consequently there is no need to wet-rag the product during the installation process. The maximum working pressures are higher, as detailed in the table.

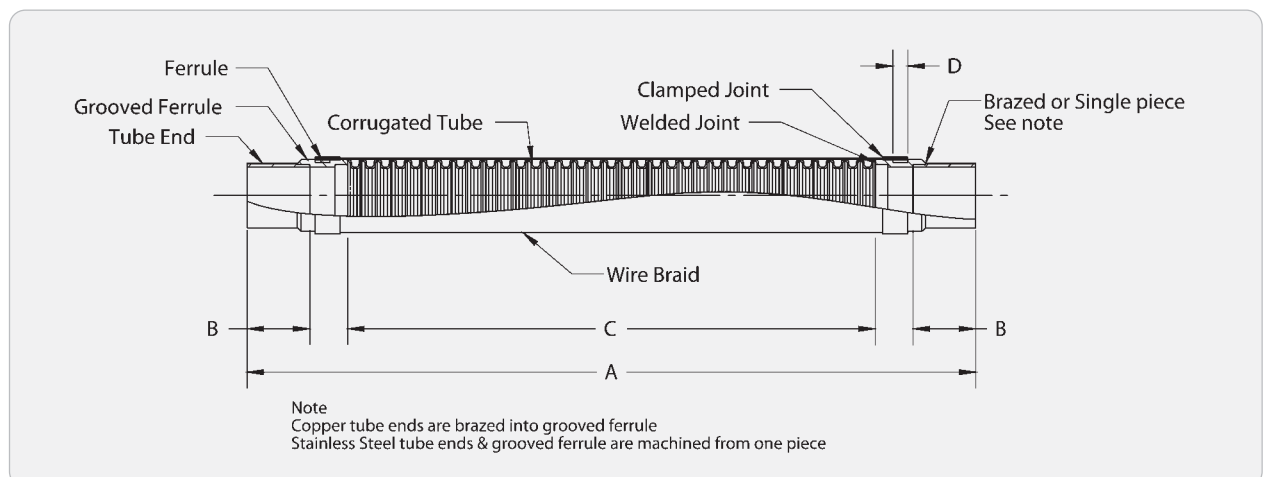

VIBRATION ELIMINATORS

V and VS Series (Imperial range)

Part No		ODS (inch)	Dimensions (mm)				MWP (barg)		Weight (kg)	CE Cat
			A	B	C	D	V Series	VS Series		
V Series	VS Series		(+/-6)	(+/-3)	(+/-3)	(+/-1.5)	V Series	VS Series		
V-1/4	VS-1/4	1/4	202	17	133	10	44.8	60.0	0.14	SEP
V-3/8	VS-3/8	3/8	215	18	141	10	44.8	60.0	0.14	SEP
V-1/2	VS-1/2	1/2	225	18	151	10	44.8	60.0	0.15	SEP
V-5/8	VS-5/8	5/8	247	20	169	10	44.8	60.0	0.21	SEP
V-3/4	VS-3/4	3/4	266	23	180	11	44.8	60.0	0.32	SEP
V-7/8	VS-7/8	7/8	301	25	211	11	44.8	60.0	0.31	SEP
V-1-1/8	VS-1-1/8	1-1/8	329	32	223	12	41.3	60.0	0.42	SEP
V-1-3/8	VS-1-3/8	1-3/8	392	35	274	14	37.9	60.0	0.66	Cat I
V-1-5/8	VS-1-5/8	1-5/8	425	40	295	16	35.1	45.0	0.98	Cat I
V-2-1/8	VS-2-1/8	2-1/8	520	50	370	16	27.5	40.0	1.46	Cat I
V-2-5/8	VS-2-5/8	2-5/8	613	60	434	19	24.1	35.0	2.60	Cat I
V-3-1/8	VS-3-1/8	3-1/8	680	70	481	19	22.0	30.0	3.60	Cat I
V-3-5/8	VS-3-5/8	3-5/8	812	85	579	21	13.0	20.0	4.70	Cat I
V-4-1/8	VS-4-1/8	4-1/8	832	90	589	21	13.0	20.0	5.50	Cat I

V and VS Series (Metric range)

Part No		ODS (mm)	Dimensions (mm)				MWP (barg)		Weight (kg)	CE Cat
			A	B	C	D	V Series	VS Series		
V Series	VS Series		(+/-6)	(+/-3)	(+/-3)	(+/-1.5)	V Series	VS Series		
V-6M	VS-6M	6	202	17	133	10	44.8	60.0	0.14	SEP
V-10M	VS-10M	10	215	18	141	10	44.8	60.0	0.14	SEP
V-12M	VS-12M	12	225	18	151	10	44.8	60.0	0.15	SEP
V-5/8	VS-5/8	16	247	20	169	10	44.8	60.0	0.21	SEP
V-7/8	VS-7/8	22	301	25	211	11	44.8	60.0	0.31	SEP
V-28M	VS-28M	28	329	32	223	12	41.3	60.0	0.42	SEP
V-1-3/8	VS-1-3/8	35	392	35	274	14	37.9	60.0	0.66	Cat I
V-42M	VS-42M	42	425	40	295	16	35.1	45.0	0.98	Cat I
V-2-1/8	VS-2-1/8	54	520	50	370	16	27.5	40.0	1.46	Cat I
V64M	VS-64M	64	613	60	434	19	24.1	35.0	2.60	Cat I
V76M	VS-76M	76	680	70	481	19	22.0	30.0	3.60	Cat I
V-89M	VS-89M	89	812	85	579	21	13.0	20.0	4.70	Cat I
V-108M	VS-108M	108	832	90	589	21	13.0	20.0	5.50	Cat I

Note: The V Series is dual CE and UL approved where applicable.

Installation – main issues

1. The vibration eliminator should be fitted as close to the compressor as possible and must be installed in a straight line. Vibration eliminators are not designed to compensate for pipework misalignment.
2. Care should be taken to allow sufficient space for the vibration eliminator to avoid static compression or tension, after brazing in place. Vibration eliminators are not designed to absorb axial or torsional stress.
3. Vibration eliminators should be installed perpendicular to the direction of vibration. When vibration exists in two planes, two vibration eliminators should be used. Refer to Figs 1 and 2.
4. For optimum absorption of vibration, the refrigerant line should be anchored at the end of the vibration eliminator furthest from the vibration source.
5. Take special care to install vibration eliminators horizontally when used in suction lines or where operating temperatures are below freezing point. Condensation may form on the outside of the unit and if installed vertically this may accumulate in the lower braid collar. In subsequent freezing this may deform and destroy the unit. If vertical installation is the only option, or indeed if condensation is possible with horizontal mounting, the entire flexible section, ferrules and braided hose, must be covered with a watertight synthetic material e.g. a heat shrinkable PVC sleeve.
6. The ferrule and start of braid must be wet-ragged for brazing when installing the V series to prevent overheating and subsequent damage.

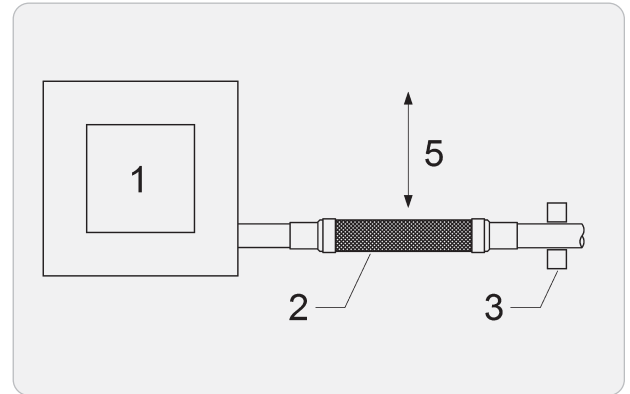

FIG. 1 SINGLE SYSTEM

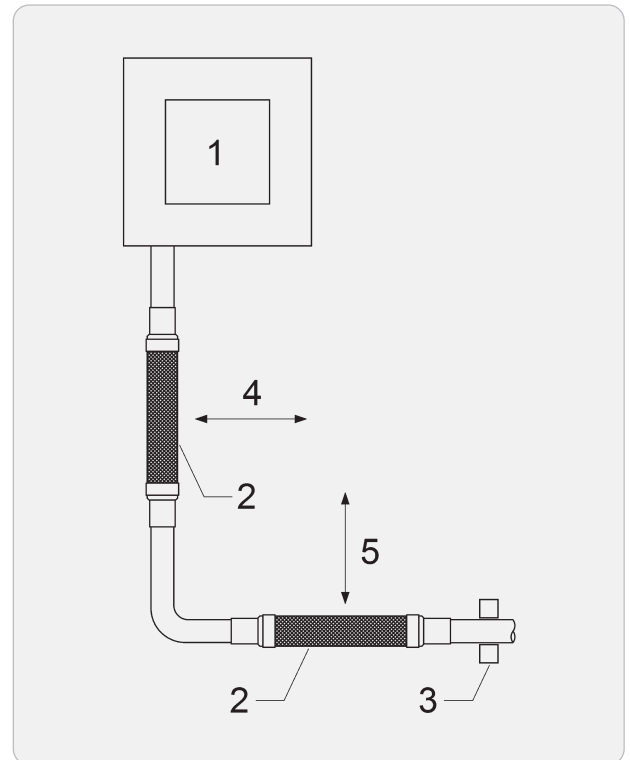

FIG. 2 DOUBLE SYSTEM

- ① Compressor
- ② Vibration eliminator
- ③ Secure to solid member
- ④ Horizontal motion
- ⑤ Vertical motion

SIGHT GLASSES

The function of a Sight glass is to allow visual inspection of liquid levels.

Applications

Sight glasses are used in air conditioning and refrigeration systems for both liquid refrigerant and oil applications.

The SG-12 series sight glasses are suitable for HCFC and HFC refrigerants, along with their associated oils.

The SG-10 and SG-11 series sight glasses are suitable for HCFC, HFC and ammonia refrigerants, along with their associated oils.

Main Features

- Three sight glass lens options- Reflex, Clear and Clear with float ball
- Fused glass hermetic seal

Technical Specification

Allowable operating pressure = Refer to table

SG-10 & SG-11 series:

Allowable operating temperature = -15°C to +120°C

SG-12 series:

Allowable operating temperature = -15°C to +120°C



Materials of Construction

The sight glass consists of a plated steel body with a built-in fused glass lens. The S-12 series is fitted with a stainless steel screen and plastic float ball.

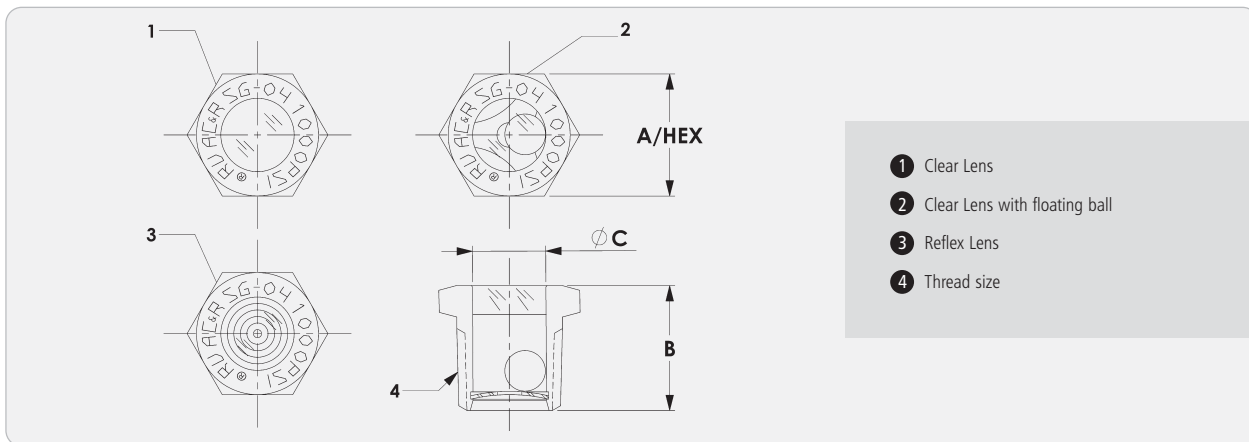

- ① Clear Lens
- ② Clear Lens with floating ball
- ③ Reflex Lens
- ④ Thread size

SIGHT GLASSES

Part No			Thread Size (NPT)	Dimensions (mm)			MWP (barg)	Weight (kg)	CE Cat
Clear	Reflex	*Clear W/Ball		A Hex	B	ØC			
SG-1004	SG-1104	SG-1204	1/2	23.9	24.3	14.3	68.9	0.03	SEP
SG-1006	SG-1106	SG-1206	3/4	28.4	26.9	19.1	68.9	0.06	SEP
SG-1008	SG-1108	SG-1208	1	35.1	33.6	23.8	68.9	0.12	SEP
SG-1010-CE	SG-1110-CE	SG-1210	1 1/4	44.5	35	30.2	34.5**	0.20	SEP (Cat II)#
SG-1012-CE	SG-1112-CE	SG-1212-CE	1 1/2	50.8	35.9	33.4	34.5**	0.29	Cat I (Cat II) #
SG-1016-CE	SG-1116-CE	SG-1216-CE	2	63.5	36.1	41.4	34.5**	0.46	Cat I (Cat II) #

*SG-12 Series is not suitable for use with ammonia. **Higher working pressures available on request.

#CE Cat Brackets indicates classification for ammonia

Installation – Main issues

1. Over-tightening should be avoided to prevent sight glass cracking.

SEALED FILTER DRIERS

The function of a filter drier is to remove system contaminants, acid and moisture.

Applications

Sealed Filter Driers are designed to protect refrigeration and air-conditioning systems by removing moisture, acids and solid particles. Sealed Filter Driers are for use in the liquid line of the system. The range is suitable for use with HCFC, HFC and CO₂ refrigerants (see core data).

Main features

- Available with solid copper solder connections or steel flare connections
- Solid core for drying/acid removal
- Filter pad and mesh to remove solid particles
- Suitable for HCFC, HFC and CO₂ refrigerants

Cores

'M' Core

- 100% Molecular Sieve
- High drying capacity
- Suitable for HCFC, HFC and CO₂ refrigerants.

'A' Core

- 80% Molecular Sieve and 20% Activated Alumina
- Absorbs moisture and acid in the system
- Not suitable for oils containing additives.
- Suitable for HCFC, HFC and CO₂ refrigerants

Materials of Construction

The shell is constructed from carbon steel and powder coated for corrosion resistance. Connections are available as either copper ODS or steel flare type. Each core is constructed from a moulded composite of desiccant materials bonded to provide very high mechanical strength, micronic filtration and high moisture absorption. The 'A' core also provides acid removal.



Technical Specification

Allowable operating temperature = -40°C to +100°C

Allowable operating pressure = 0 to 45 barg

Selection Guidelines

The user should select the appropriate core based on refrigerant and oil types (see note). The model should then be selected based on the required drying and liquid capacities.

Note: Cores with Activated Alumina (type 'A') are not recommended for use with oils containing additives.

Installation – Main Issues

1. Install the filter drier upstream of the liquid line controls to give maximum protection. Locate upstream of moisture indicator so that drying effectiveness can be measured.
2. Ensure the indicated flow direction is complied with.



SAE FLARE MODELS

Part No	Conn Size (inch)	Shell Diameter (mm)	A (mm)	ØB (mm)	C (mm)	Weight (kg)	CE Cat
SDM/SDA-032	1/4	46	63	46	110	0.26	SEP
SDM/SDA-033	3/8	46	63	46	120	0.31	SEP
SDM/SDA-052	1/4	65	72	65	119	0.40	SEP
SDM/SDA-053	3/8	65	72	65	129	0.44	SEP
SDM/SDA-082	1/4	65	98	65	145	0.52	SEP
SDM/SDA-083	3/8	65	98	65	155	0.55	SEP
SDM/SDA-084	1/2	65	98	65	163	0.58	SEP
SDM/SDA-162	1/4	78	112	78	159	0.75	SEP
SDM/SDA-163	3/8	78	112	78	169	0.79	SEP
SDM/SDA-164	1/2	78	112	78	177	0.83	SEP
SDM/SDA-165	5/8	78	112	78	185	0.90	SEP
SDM/SDA-303	3/8	78	185	78	242	1.24	SEP
SDM/SDA-304	1/2	78	185	78	250	1.29	SEP
SDM/SDA-305	5/8	78	185	78	258	1.35	SEP
SDM/SDA-306	3/4	78	185	78	264	1.37	SEP
SDM/SDA-413	3/8	92	192	92	249	1.87	Cat I
SDM/SDA-414	1/2	92	192	92	257	1.89	Cat I
SDM/SDA-415	5/8	92	192	92	265	1.94	Cat I
SDM/SDA-416	3/4	92	192	92	271	1.97	Cat I

ODS MODELS

Part No	Conn Size (inch)	Shell Diameter (mm)	A (mm)	ØB (mm)	C (mm)	D (mm)	Weight (kg)	CE Cat
SDM/SDA-032S	1/4	46	63	46	81	13	0.23	SEP
SDM/SDA-033S	3/8	46	63	46	85	13	0.26	SEP
SDM/SDA-052S	1/4	65	72	65	90	13	0.36	SEP
SDM/SDA-053S	3/8	65	72	65	94	13	0.38	SEP
SDM/SDA-082S	1/4	65	98	65	116	13	0.48	SEP
SDM/SDA-083S	3/8	65	98	65	120	13	0.49	SEP
SDM/SDA-084S	1/2	65	98	65	122	13	0.50	SEP
SDM/SDA-162S	1/4	78	112	78	130	13	0.76	SEP
SDM/SDA-163S	3/8	78	112	78	134	13	0.81	SEP
SDM/SDA-164S	1/2	78	112	78	136	13	0.82	SEP
SDM/SDA-165S	5/8	78	112	78	134	13	0.90	SEP
SDM/SDA-303S	3/8	78	185	78	207	13	1.21	SEP
SDM/SDA-304S	1/2	78	185	78	209	13	1.25	SEP
SDM/SDA-305S	5/8	78	185	78	220	13	1.27	SEP
SDM/SDA-306S	3/4	78	185	78	209	15	1.29	SEP
SDM/SDA-413S	3/8	92	192	92	214	13	1.81	Cat I
SDM/SDA-414S	1/2	92	192	92	216	13	1.82	Cat I
SDM/SDA-415S	5/8	92	192	92	214	13	1.83	Cat I
SDM/SDA-416S	3/4	92	192	92	216	15	1.84	Cat I

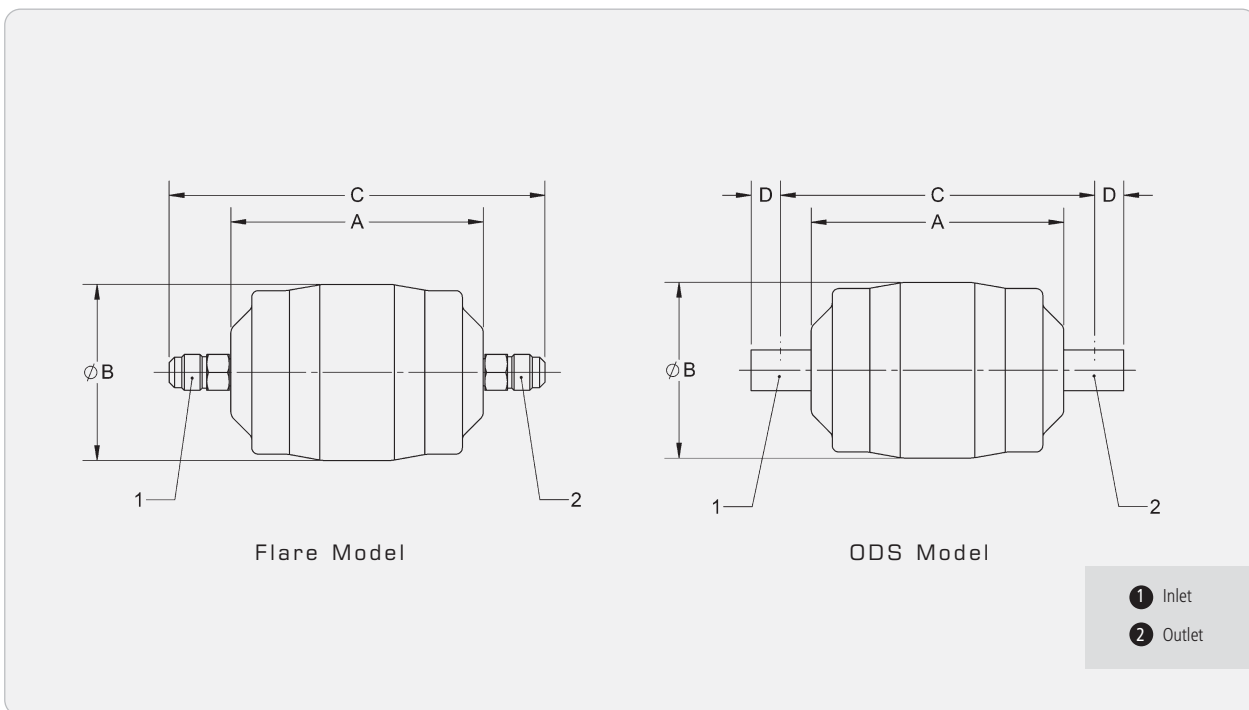

- 1 Inlet
- 2 Outlet

DRYING AND LIQUID CAPACITY TABLE - 'M' CORE

Model Details		Drying Capacity (kg of refrigerant)								Liquid Capacity (kW)					
Part No	Conn Size (inch)	R22		R134a		R404A/R507		R407C/R410A		R-22	R-134a	R-404A	R-407C	R-410A	CO ₂
		24°C	52°C	24°C	52°C	24°C	52°C	24°C	52°C						
SDM-032/S	1/4	4.9	4.6	5.3	5	7.8	4.8	5.3	4.6	6.1	5.8	3.2	6.1	6.5	8.9
SDM-033/S	3/8	4.9	4.6	5.3	5	7.8	4.8	5.3	4.6	20.8	17.7	10.3	20.8	22.1	27.1
SDM-052/S	1/4	9.8	9.1	10.6	10.1	15.6	9.6	10.6	9.1	7.7	6.4	3.5	7.7	8.2	9.8
SDM-053/S	3/8	9.8	9.1	10.6	10.1	15.6	9.6	10.6	9.1	19	17.2	10.2	19	20.2	26.3
SDM-082/S	1/4	15.8	14.6	16.9	16.1	24.9	15.4	17	14.6	7.9	6.6	3.6	7.9	8.5	10.1
SDM-083/S	3/8	15.8	14.6	16.9	16.1	24.9	15.4	17	14.6	21.7	18.7	10.5	21.7	23.1	28.7
SDM-084/S	1/2	15.8	14.6	16.9	16.1	24.9	15.4	17	14.6	31.1	26.7	15.6	31.1	33.2	40.8
SDM-162/S	1/4	24.6	22.8	26.4	25.2	38.9	24.1	26.6	22.8	8.6	7.2	3.9	8.6	9.2	11
SDM-163/S	3/8	24.6	22.8	26.4	25.2	38.9	24.1	26.6	22.8	23	20.1	11.1	23	24.5	30.8
SDM-164/S	1/2	24.6	22.8	26.4	25.2	38.9	24.1	26.6	22.8	34.9	30.3	16.9	34.9	37.3	46.4
SDM-165/S	5/8	24.6	22.8	26.4	25.2	38.9	24.1	26.6	22.8	34.4	30.1	16	34.4	36.7	46.1
SDM-303/S	3/8	51.2	47.4	55	52.3	81	50	55.3	47.4	23.2	20.2	11	23.2	24.7	31
SDM-304/S	1/2	51.2	47.4	55	52.3	81	50	55.3	47.4	35.7	31.1	16.8	35.7	38.1	47.6
SDM-305/S	5/8	51.2	47.4	55	52.3	81	50	55.3	47.4	43.5	38.2	21.3	43.5	46.4	58.4
SDM-306/S	3/4	51.2	47.4	55	52.3	81	50	55.3	47.4	64.3	56	30.9	64.3	68.5	85.6
SDM-413/S	3/8	76.8	71.2	82.4	78.5	121.4	75	82.9	71.1	26.3	23.2	12.7	26.3	28	35.5
SDM-414/S	1/2	76.8	71.2	82.4	78.5	121.4	75	82.9	71.1	41.6	36.4	19.9	41.6	44.4	55.6
SDM-415/S	5/8	76.8	71.2	82.4	78.5	121.4	75	82.9	71.1	58.3	50.9	27.1	58.3	62.2	77.9
SDM-416/S	3/4	76.8	71.2	82.4	78.5	121.4	75	82.9	71.1	67.7	59.1	31.4	67.7	72.2	90.4

DRYING AND LIQUID CAPACITY TABLE - 'A' CORE

Model Details		Drying Capacity (kg of refrigerant)								Liquid Capacity (kW)					
Part No	Conn Size (inch)	R22		R134a		R404A/R507		R407C/R410A		R-22	R-134a	R-404A	R-407C	R-410A	CO ₂
		24°C	52°C	24°C	52°C	24°C	52°C	24°C	52°C						
SDA-032/S	1/4	4.3	4	4.6	4.4	7.4	4	4.5	3.9	6.1	5.8	3.2	6.1	6.5	8.9
SDA-033/S	3/8	4.3	4	4.6	4.4	7.4	4	4.5	3.9	20.8	17.7	10.3	20.8	22.1	27.1
SDA-052/S	1/4	8.6	8	9.2	8.8	14.8	8	9.1	7.7	7.7	6.4	3.5	7.7	8.2	9.8
SDA-053/S	3/8	8.6	8	9.2	8.8	14.8	8	9.1	7.7	19	17.2	10.2	19	20.2	26.3
SDA-082/S	1/4	13.8	12.8	14.8	14.1	23.7	12.8	14.5	12.4	7.9	6.6	3.6	7.9	8.5	10.1
SDA-083/S	3/8	13.8	12.8	14.8	14.1	23.7	12.8	14.5	12.4	21.7	18.7	10.5	21.7	23.1	28.7
SDA-084/S	1/2	13.8	12.8	14.8	14.1	23.7	12.8	14.5	12.4	31.1	26.7	15.6	31.1	33.2	40.8
SDA-162/S	1/4	21.5	19.9	23.1	22	37	19.9	22.6	19.3	8.6	7.2	3.9	8.6	9.2	11
SDA-163/S	3/8	21.5	19.9	23.1	22	37	19.9	22.6	19.3	23	20.1	11.1	23	24.5	30.8
SDA-164/S	1/2	21.5	19.9	23.1	22	37	19.9	22.6	19.3	34.9	30.3	16.9	34.9	37.3	46.4
SDA-165/S	5/8	21.5	19.9	23.1	22	37	19.9	22.6	19.3	34.4	30.1	16	34.4	36.7	46.1
SDA-303/S	3/8	44.8	41.5	48.1	45.7	77	41.5	47.1	40.2	23.2	20.2	11	23.2	24.7	31
SDA-304/S	1/2	44.8	41.5	48.1	45.7	77	41.5	47.1	40.2	35.7	31.1	16.8	35.7	38.1	47.6
SDA-305/S	5/8	44.8	41.5	48.1	45.7	77	41.5	47.1	40.2	43.5	38.2	21.3	43.5	46.4	58.4
SDA-306/S	3/4	44.8	41.5	48.1	45.7	77	41.5	47.1	40.2	64.3	56	30.9	64.3	68.5	85.6
SDA-413/S	3/8	67.1	62.2	72.1	68.6	115.5	62.2	70.6	60.2	26.3	23.2	12.7	26.3	28	35.5
SDA-414/S	1/2	67.1	62.2	72.1	68.6	115.5	62.2	70.6	60.2	41.6	36.4	19.9	41.6	44.4	55.6
SDA-415/S	5/8	67.1	62.2	72.1	68.6	115.5	62.2	70.6	60.2	58.3	50.9	27.1	58.3	62.2	77.9
SDA-416/S	3/4	67.1	62.2	72.1	68.6	115.5	62.2	70.6	60.2	67.7	59.1	31.4	67.7	72.2	90.4

Drying Capacity is based on the following moisture content before and after drying:

- R22:** From 1050 ppm W to 60 ppw W in accordance with ARI 710-86
- R134a:** From 1050 ppm W to 75 ppm W. If refrigerant is to be dried to 50 ppm W, reduce the stated capacities by 15%
- R404A, R407C, R507:** From 1020 ppm W to 30 ppm W
- R410A:** From 1050 ppm W to 60 ppm W

Liquid Capacity is based on:

- Evaporating temperature of $t_e = -15^\circ\text{C}$ (-30°C for CO_2)
- Condensing temperature of $t_c = +30^\circ\text{C}$ (-5°C for CO_2)
- Pressure drop across filter drier of $\Delta p = 0.07$ bar

SURFACE AND VOLUME INFORMATION

Model	Core surface area	Core Volume	Shell Volume
	cm ²	cm ³	ltr
SDM/SDA-03	64	43	0.1
SDM/SDA-05	127	90	0.2
SDM/SDA-08	180	146	0.3
SDM/SDA-16	290	219	0.5
SDM/SDA-30	442	451	0.9
SDM/SDA-41	551	649	1.3

ACID CAPACITY INFORMATION

Model	Acid Capacity*
	g
SDA-03	0.8
SDA-05	1.6
SDA-08	2.6
SDA-16	4
SDA-30	8.3
SDA-41	12.5

*Absorption capacity of oleic acid at 0.05 TAN (Total Acid Number)

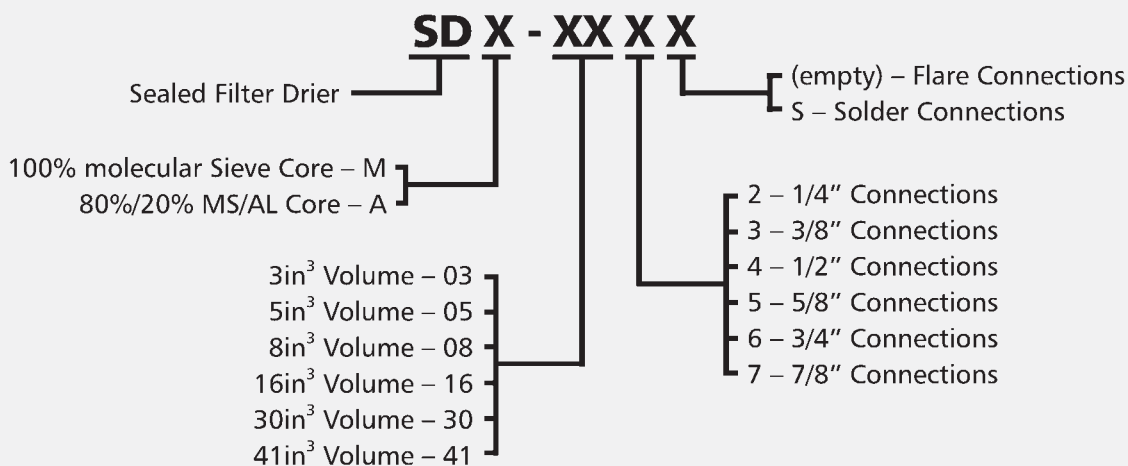

Example Code: SDM-082S

REPLACEABLE CORE FILTER DRIERS

The function of a filter drier is to remove system contaminants, acid and moisture.

Applications

The Henry Technologies range of replaceable core filter driers are designed to be used in both the liquid and suction lines of refrigeration and air-conditioning systems. The product range is suitable for use with HCFC, HFC and CO₂ refrigerants (see core data).

Main features

- Proven system protector
- High filtering capability
- High moisture absorption and acid removal
- Stainless steel mesh screen
- Solid copper full flow connections
- Interchangeable cores
- Corrosion-resistant, powder coated shells
- 1/4 NPT Pressure Tapping
- Nickel Plated Steel Cover Plate

Cores

S-848-CM

- 100% molecular sieve
- High drying capacity
- Suitable for HCFC, HFC and CO₂ refrigerants

S-848-C

- 80% molecular sieve and 20% activated alumina
- Absorbs moisture and acid in the system
- Suitable for HCFC, HFC and CO₂ refrigerants
- Not suitable for oils containing additives

S-848-CC

- 47/48/5% molecular sieve/activated alumina/activated carbon
- High acid absorption
- Suitable for use after compressor burnout
- Suitable for HCFC, HFC and CO₂ refrigerants
- Not suitable for oils containing additives

S-848-SC

- 100% molecular sieve
- Low pressure drop
- Suitable for HCFC, HFC and CO₂ refrigerants

S-848-F

- Filter element
- Low pressure drop
- Use when moisture removal is not required

Note: Cores not included with drier shells - to be ordered separately



Materials of Construction

Drier Shells

The main shell and fixed end cap are constructed from carbon steel and are powder coated for corrosion resistance. The cover plate is constructed from nickel plated steel. The ODS connections are copper.

Cores

Each core is constructed from a moulded composite of desiccant material(s) bonded to provide very high mechanical strength, micronic filtration, high moisture absorption and acid removal where applicable. Each core is fully activated and placed in a hermetically sealed container.

Technical Specification

Allowable operating temperature = -40°C to +70°C

Allowable operating pressure = 0 to 42 barg

Selection Guidelines

The user should select a model based on refrigerant type, refrigeration capacity and the preferred degree of moisture/acid removal required. The preferred connection size can then be matched to the system requirements to establish which model is best. Alternatively, the user may select a connection size first and then check that the application is within the refrigeration capacity limits of the selected model.

Note: The user may decide to oversize the filter drier based on experience or if the system contamination level is likely to be higher than normal.

Installation – Main Issues

1. Install the filter drier upstream of the liquid line controls to give maximum protection. Locate upstream of moisture indicator so that drying effectiveness can be measured.
2. Ensure dimension 'F' is complied with in order to remove cores.
3. It is recommended to install the unit horizontally for easier core replacement.

Replaceable Core Filter Drier Shells

Model Details			Core Data		Dimensions (mm)						Weight (kg)	CE Cat
Part No	Conn. Size (inch)	Cores	Surface Area (cm ²)	Volume (cm ³)	A	B	C	D	E	F*		
SRC-485	5/8	1	683	716	172	115	58	274	114	172	4.78	Cat I
SRC-965	5/8	2	1366	1432	312	115	58	414	114	312	6.12	Cat I
SRC-1445	5/8	3	2049	2148	456	115	58	558	114	456	7.49	Cat II
SRC-1925	5/8	4	2732	2864	599	115	58	701	114	599	9.00	Cat II
SRC-487	7/8	1	683	716	172	115	58	274	114	172	4.81	Cat I
SRC-967	7/8	2	1366	1432	312	115	58	414	114	312	6.15	Cat I
SRC-1447	7/8	3	2049	2148	456	115	58	558	114	456	7.52	Cat II
SRC-1927	7/8	4	2732	2864	599	115	58	701	114	599	9.02	Cat II
SRC-489	1 1/8	1	683	716	172	115	58	274	114	172	4.83	Cat I
SRC-969	1 1/8	2	1366	1432	312	115	58	414	114	312	6.23	Cat I
SRC-1449	1 1/8	3	2049	2148	456	115	58	558	114	456	7.64	Cat II
SRC-1929	1 1/8	4	2732	2864	599	115	58	701	114	599	9.10	Cat II
SRC-4811	1 3/8	1	683	716	172	115	58	274	114	172	4.93	Cat I
SRC-9611	1 3/8	2	1366	1432	312	115	58	414	114	312	6.30	Cat I
SRC-14411	1 3/8	3	2049	2148	456	115	58	558	114	456	7.68	Cat II
SRC-19211	1 3/8	4	2732	2864	599	115	58	701	114	599	9.12	Cat II
SRC-4813	1 5/8	1	683	716	172	115	58	274	114	172	4.99	Cat I
SRC-9613	1 5/8	2	1366	1432	312	115	58	414	114	312	6.32	Cat I
SRC-14413	1 5/8	3	2049	2148	456	115	58	558	114	456	8.01	Cat II
SRC-19213	1 5/8	4	2732	2864	599	115	58	701	114	599	9.16	Cat II
SRC-4817	2 1/8	1	683	716	172	115	58	274	114	172	5.03	Cat I
SRC-9617	2 1/8	2	1366	1432	312	115	58	414	114	312	6.47	Cat I
SRC-14417	2 1/8	3	2049	2148	456	115	58	558	114	456	7.83	Cat II
SRC-19217	2 1/8	4	2732	2864	599	115	58	701	114	599	9.26	Cat II
SRC-4821	2 5/8	1	683	716	172	115	58	274	114	172	5.34	Cat I
SRC-9621	2 5/8	2	1366	1432	312	115	58	414	114	312	6.71	Cat I
SRC-14421	2 5/8	3	2049	2148	456	115	58	558	114	456	8.02	Cat II
SRC-19221	2 5/8	4	2732	2864	599	115	58	701	114	599	9.58	Cat II

*'F' is the minimum space required to remove the filter drier cores from the shell.

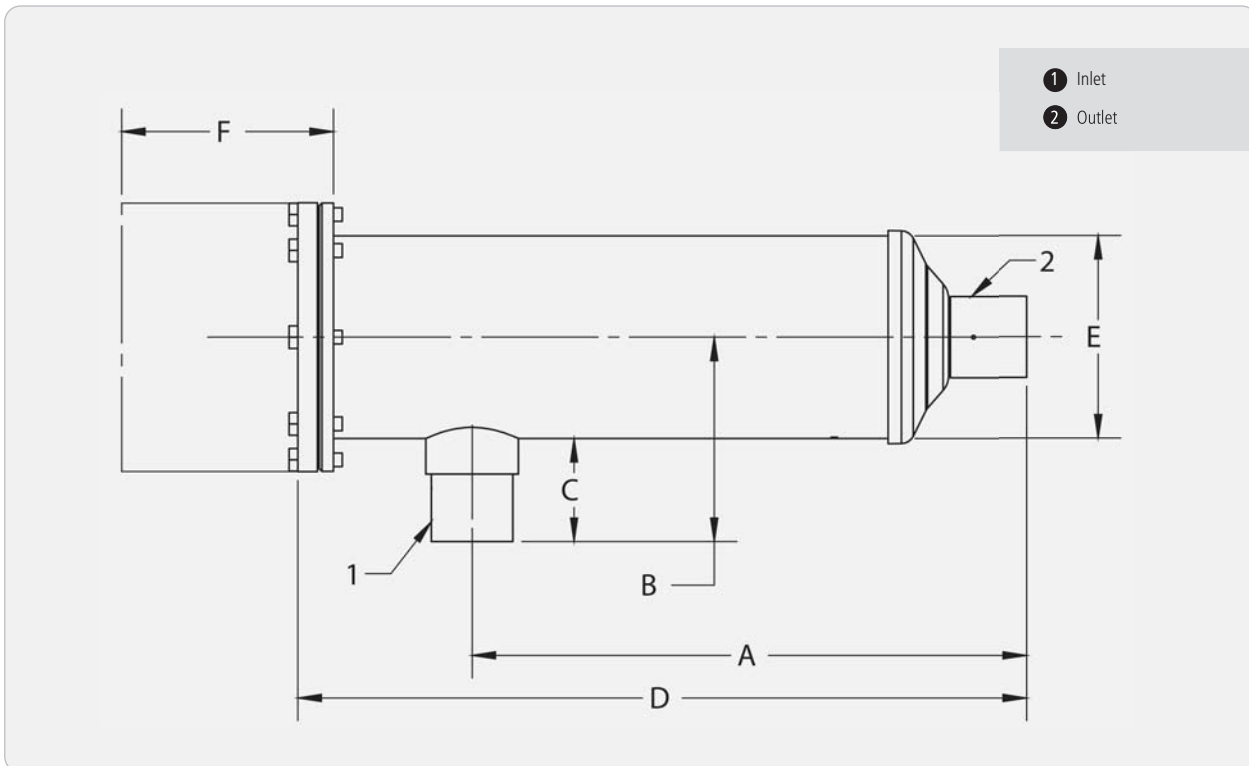

S-848-CM Core

Model Details			Drying Capacity (kg of refrigerant)						Liquid Capacity (kW)					
Part No	Conn. Size (inch)	Cores	R134a		R404A/R507		R407C/R410A		R134a	R404A	R507	R407C	R410A	CO ₂
			24 °C	52 °C	24 °C	52 °C	24 °C	52 °C						
SRC-485	5/8	1	83.5	79.5	123	76	84	72	78.2	57.6	55.8	81.9	85.3	125.9
SRC-965	5/8	2	167	159	246	152	168	144	73.1	53.4	51.7	76.1	79.0	117.6
SRC-1445	5/8	3	250.5	238.5	369	228	252	216	73.1	53.4	51.7	76.1	79.0	117.6
SRC-1925	5/8	4	334	318	492	304	336	288	73.1	53.4	51.7	76.1	79.0	117.6
SRC-487	7/8	1	83.5	79.5	123	76	84	72	124.2	89.7	86.9	128.6	132.7	197.0
SRC-967	7/8	2	167	159	246	152	168	144	116.0	83.1	80.5	119.5	122.8	184.1
SRC-1447	7/8	3	250.5	238.5	369	228	252	216	116.0	83.1	80.5	119.5	122.8	184.1
SRC-1927	7/8	4	334	318	492	304	336	288	116.0	83.1	80.5	119.5	122.8	184.1
SRC-489	1 1/8	1	83.5	79.5	123	76	84	72	178.8	128.6	124.5	184.7	190.0	283.7
SRC-969	1 1/8	2	167	159	246	152	168	144	178.1	128.2	124.0	183.9	189.1	282.7
SRC-1449	1 1/8	3	250.5	238.5	369	228	252	216	173.3	124.7	120.8	179.1	184.2	275.1
SRC-1929	1 1/8	4	334	318	492	304	336	288	173.3	124.7	120.8	179.1	184.2	275.1
SRC-4811	1 3/8	1	83.5	79.5	123	76	84	72	236.8	171.5	166.1	245.6	253.5	375.9
SRC-9611	1 3/8	2	167	159	246	152	168	144	241.5	174.1	168.7	249.8	257.3	383.3
SRC-14411	1 3/8	3	250.5	238.5	369	228	252	216	253.4	183.1	177.4	262.4	270.5	402.2
SRC-19211	1 3/8	4	334	318	492	304	336	288	263.9	192.6	186.6	275.1	284.9	418.8
SRC-4813	1 5/8	1	83.5	79.5	123	76	84	72	273.7	199.8	193.6	285.4	295.7	434.3
SRC-9613	1 5/8	2	167	159	246	152	168	144	298.7	216.7	210.0	310.2	320.5	474.1
SRC-14413	1 5/8	3	250.5	238.5	369	228	252	216	299.3	217.2	210.4	310.8	321.1	475.0
SRC-19213	1 5/8	4	334	318	492	304	336	288	309.4	225.1	218.1	321.8	332.8	491.1
SRC-4817	2 1/8	1	83.5	79.5	123	76	84	72	399.6	298.2	289.2	422.6	442.2	634.1
SRC-9617	2 1/8	2	167	159	246	152	168	144	419.9	307.2	297.7	438.4	454.6	666.4
SRC-14417	2 1/8	3	250.5	238.5	369	228	252	216	367.1	268.1	259.8	382.9	396.7	582.6
SRC-19217	2 1/8	4	334	318	492	304	336	288	429.8	311.1	301.4	445.7	459.9	682.0
SRC-4821	2 5/8	1	83.5	79.5	123	76	84	72	294.9	215.6	209.1	307.7	318.9	460.4
SRC-9621	2 5/8	2	167	159	246	152	168	144	316.5	238.1	230.7	341.1	351.7	517.6
SRC-14421	2 5/8	3	250.5	238.5	369	228	252	216	282.4	221.7	214.8	317.0	327.8	482.0
SRC-19221	2 5/8	4	334	318	492	304	336	288	337.4	273.5	264.9	391.3	404.2	598.8

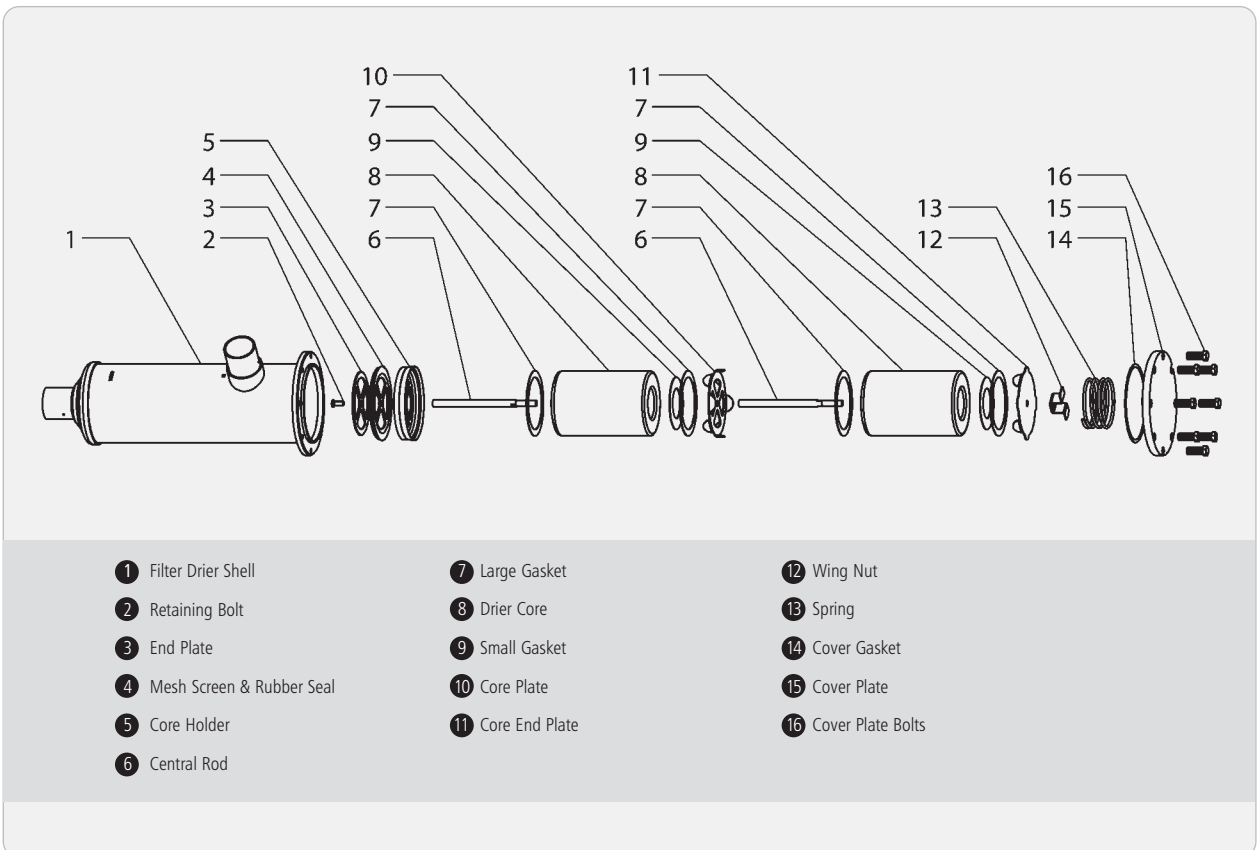

S-848-C Core

Model Details			Drying Capacity (kg of refrigerant)								Liquid Capacity (kW)					
Part No	Conn. Size (inch)	Cores	R22		R134a		R404A/R507		R407C/R410A		R134a	R404A	R507	R22 /R407C	R410A	CO ₂
			24 °C	52 °C	24 °C	52 °C	24 °C	52 °C	24 °C	52 °C						
SRC-485	5/8	1	68	63	73	69.5	117	63	71.5	61	83.7	57.6	55.8	81.9	85.3	127.6
SRC-965	5/8	2	136	126	146	139	234	126	143	122	78.2	53.4	51.7	76.1	79.0	119.2
SRC-1445	5/8	3	204	189	219	208.5	351	189	214.5	183	78.2	53.4	51.7	76.1	79.0	119.2
SRC-1925	5/8	4	272	252	292	278	468	252	286	244	78.2	53.4	51.7	76.1	79.0	119.2
SRC-487	7/8	1	68	63	73	69.5	117	63	71.5	61	124.2	89.7	86.9	128.6	132.7	197.0
SRC-967	7/8	2	136	126	146	139	234	126	143	122	116.0	83.1	80.5	119.5	122.8	184.1
SRC-1447	7/8	3	204	189	219	208.5	351	189	214.5	183	116.0	83.1	80.5	119.5	122.8	184.1
SRC-1927	7/8	4	272	252	292	278	468	252	286	244	116.0	83.1	80.5	119.5	122.8	184.1
SRC-489	1 1/8	1	68	63	73	69.5	117	63	71.5	61	178.8	128.6	124.5	184.7	190.0	283.7
SRC-969	1 1/8	2	136	126	146	139	234	126	143	122	178.1	128.2	124.0	183.9	189.1	282.7
SRC-1449	1 1/8	3	204	189	219	208.5	351	189	214.5	183	173.3	124.7	120.8	179.1	184.2	275.1
SRC-1929	1 1/8	4	272	252	292	278	468	252	286	244	173.3	124.7	120.8	179.1	184.2	275.1
SRC-4811	1 3/8	1	68	63	73	69.5	117	63	71.5	61	236.8	171.5	166.1	245.6	253.5	375.9
SRC-9611	1 3/8	2	136	126	146	139	234	126	143	122	241.5	174.1	168.7	249.8	257.3	383.3
SRC-14411	1 3/8	3	204	189	219	208.5	351	189	214.5	183	253.4	183.1	177.4	262.4	270.5	402.2
SRC-19211	1 3/8	4	272	252	292	278	468	252	286	244	263.9	192.6	186.6	275.1	284.9	418.8
SRC-4813	1 5/8	1	68	63	73	69.5	117	63	71.5	61	273.7	199.8	193.6	285.4	295.7	434.3
SRC-9613	1 5/8	2	136	126	146	139	234	126	143	122	298.7	216.7	210.0	310.2	320.5	474.1
SRC-14413	1 5/8	3	204	189	219	208.5	351	189	214.5	183	299.3	217.2	210.4	310.8	321.1	475.0
SRC-19213	1 5/8	4	272	252	292	278	468	252	286	244	309.4	225.1	218.1	321.8	332.8	491.1
SRC-4817	2 1/8	1	68	63	73	69.5	117	63	71.5	61	399.6	298.2	289.2	422.6	442.2	634.1
SRC-9617	2 1/8	2	136	126	146	139	234	126	143	122	419.9	307.2	297.7	438.4	454.6	666.4
SRC-14417	2 1/8	3	204	189	219	208.5	351	189	214.5	183	367.1	268.1	259.8	382.9	396.7	582.6
SRC-19217	2 1/8	4	272	252	292	278	468	252	286	244	429.8	311.1	301.4	445.7	459.9	682.0
SRC-4821	2 5/8	1	68	63	73	69.5	117	63	71.5	61	294.9	215.6	209.1	307.7	318.9	460.4
SRC-9621	2 5/8	2	136	126	146	139	234	126	143	122	316.5	238.1	230.7	341.1	351.7	517.6
SRC-14421	2 5/8	3	204	189	219	208.5	351	189	214.5	183	282.4	221.7	214.8	317.0	327.8	482.0
SRC-19221	2 5/8	4	272	252	292	278	468	252	286	244	337.4	273.5	264.9	391.3	404.2	598.8

Drying Capacity is based on the following moisture contents before and after drying:

- R22:** From 1050 ppm W to 60 ppw W according to ARI 710-86
- R134a:** From 1050 ppm W to 75 ppm W.
- R404A, R407C, R507:** From 1020 ppm W to 30 ppm W
- R410A:** From 1050 ppm W to 60 ppm W

Liquid Capacity is based on:

- Evaporating temperature of $t_e = -15^\circ\text{C}$ (-30°C for CO_2)
- Condensing temperature of $t_c = +30^\circ\text{C}$ (-5°C for CO_2)
- Pressure drop across filter drier of $\Delta p = 0.07$ bar

S-848-CC

Cores	Drying Capacity (kg of refrigerant)											
	Evaporating Temperature t_e (°C)											
	-40	-20	4.4	-30	-20	4.4	-40	-20	4.4	-40	-20	4.4
	R22			R134a			R404A/R507			R407C/R410A		
1	29	20	13	46	39	27	47	31	19	43	35	25
2	58	40	26	92	78	54	94	62	38	86	70	50
3	87	60	39	138	117	81	141	93	57	129	105	75
4	116	80	52	184	156	108	188	124	76	172	140	100

Drying Capacity is expressed during drying in:

- R22:** EDP = 10 ppm W, corresponding to a dew point temperature of -50°C
- R134a:** EDP = 50 ppm W, corresponding to a dew point temperature of -37°C
- R404A:** EDP = 10 ppm W, corresponding to a dew point temperature of -40°C
- R407C:** EDP = 10 ppm W, corresponding to a dew point temperature of -40°C

Model	Refrigerant	Acid adsorb capacity (drops)	Acid capacity (grams)
S-848-C (80%/20% MS/AA)	R134a	196	10.24
	R410A	232	12.12
S-848-CC (47%/48%/5% MS/AA/C)	R134a	465	24.30
	R410A	523	27.33

Test Condition: T = 25°C, TAN = 0.3mgKOH/g of oil, Humidity = 2%

Recommended Plant Capacity in suction line (kW) S-848-CC (Burn Out)

Model Details			Evaporating Temperature t_e °C											
Part No	Conn. Size (inch)	Cores	-40	-20	4.4	-30	-20	4.4	-40	-20	4.4	-40	-20	4.4
			R22			R134a			R404A/R507			R407C/R410A		
SRC-485	5/8	1	3.0	8.6	20.4	2.9	5.2	12.6	2.3	6.9	17.0	3.0	8.6	20.4
SRC-965	5/8	2	3.2	8.8	20.8	3.1	5.5	13.0	2.4	7.2	17.5	3.2	8.9	21.0
SRC-1445	5/8	3	3.4	9.7	22.1	3.3	5.8	13.6	2.6	7.5	18.3	3.4	9.7	22.1
SRC-1925	5/8	4	4.1	11.2	266.9	3.9	6.9	16.3	3.1	8.9	22.0	4.1	11.2	26.5
SRC-487	7/8	1	5.6	15.6	36.7	5.4	9.6	22.7	4.4	12.5	30.3	5.6	15.6	36.7
SRC-967	7/8	2	5.6	15.7	37.0	5.4	9.6	22.9	4.4	12.5	30.5	5.6	15.7	37.0
SRC-1447	7/8	3	6.4	18.3	41.6	6.1	10.9	25.6	4.9	14.1	34.5	6.4	18.3	41.6
SRC-1927	7/8	4	7.7	21.0	49.9	7.4	13.0	30.7	5.9	16.9	41.4	7.7	21.0	49.9
SRC-489	1 1/8	1	7.6	21.0	49.2	7.3	12.9	30.6	5.8	16.7	40.5	7.6	21.0	49.2
SRC-969	1 1/8	2	8.2	23.1	54.8	7.9	14.1	33.7	6.4	18.5	45.2	8.2	23.1	54.8
SRC-1449	1 1/8	3	8.3	23.6	53.8	7.9	14.1	33.1	6.4	18.2	44.7	8.3	23.6	53.8
SRC-1929	1 1/8	4	10.0	27.2	64.8	9.6	16.9	39.6	7.7	21.9	53.8	10.0	27.2	64.8
SRC-4811	1 3/8	1	9.5	25.9	60.1	9.1	16.0	37.5	7.3	20.7	49.3	9.5	25.9	60.1
SRC-9611	1 3/8	2	11.1	31.1	73.7	10.6	19.0	45.5	8.6	24.9	60.8	11.1	31.1	73.7
SRC-14411	1 3/8	3	12.3	35.4	85.7	11.8	21.4	52.3	9.6	28.6	71.2	12.3	35.4	85.7
SRC-19211	1 3/8	4	13.5	38.0	90.5	13.0	23.2	55.7	10.6	30.6	74.8	13.5	38.0	90.5
SRC-4813	1 5/8	1	9.0	24.6	57.0	8.6	15.1	35.6	6.9	19.6	46.7	9.0	24.6	57.0
SRC-9613	1 5/8	2	12.7	35.9	85.7	12.2	21.9	52.7	9.9	28.8	70.8	12.7	35.9	85.7
SRC-14413	1 5/8	3	11.6	33.5	81.1	11.2	20.2	49.5	9.1	27.0	67.4	11.6	33.5	81.1
SRC-19213	1 5/8	4	15.5	43.9	105.0	15.0	26.7	64.5	12.1	35.3	86.9	15.5	43.9	105.0
SRC-4817	2 1/8	1	9.2	25.1	58.2	8.8	15.5	36.3	7.1	20.1	47.7	9.2	25.1	58.2
SRC-9617	2 1/8	2	12.4	35.1	83.8	12.0	21.4	51.5	9.7	28.2	69.3	12.4	35.1	83.8
SRC-14417	2 1/8	3	11.0	31.6	76.5	10.5	19.1	46.6	8.5	25.5	63.6	11.0	31.6	76.5
SRC-19217	2 1/8	4	15.3	43.4	103.8	14.8	26.4	63.8	12.0	34.9	85.9	15.3	43.4	103.8
SRC-4821	2 5/8	1	9.2	25.2	58.4	8.9	15.5	36.5	7.1	20.1	47.9	9.2	25.2	58.4
SRC-9621	2 5/8	2	12.1	34.0	81.1	11.6	20.7	49.9	9.4	27.3	67.0	12.1	34.0	81.1
SRC-14421	2 5/8	3	11.6	33.5	81.1	11.2	20.2	49.5	9.1	27.0	67.4	11.6	33.5	81.1
SRC-19221	2 5/8	4	14.7	41.8	99.7	14.3	25.5	61.3	11.6	33.6	82.5	14.7	41.8	99.7

Recommended plant capacity is based on:

Evaporating temperature of $t_e = +4.4^\circ\text{C}$

Condensing temperature of $t_c = +32.2^\circ\text{C}$

Drier Cores

Part No.	Material	Description	Suitability
S-848-CM	100% MS	High Drying capacity	HCFC, HFC & CO ₂ Refrigerants
S-848-C	80%/20% MS/AA	Moisture & Acid Absorption	Not suitable for oils containing additives
S-848-CC	47%/48%/5% MS/AA/C	Burn-Out Core	Not suitable for oils containing additives
S-848-SC	100% MS	Low Pressure Drop	HCFC, HFC & CO ₂ Refrigerants
S-848-F	Filter Element	Low Pressure Drop	All applications

REPLACEMENT COMPONENTS

OIL SEPARATORS

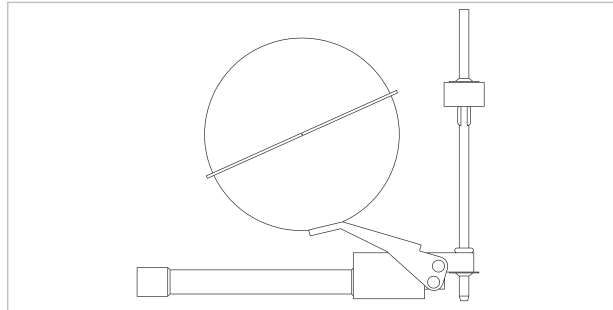

Vessel Part No	Replacement Float Assy + Gasket	Gasket only
S-588*	A-5000-30	2-023-001

Vessel Part No	Replacement Float Assy + Gasket	Gasket only
S-520*	A-2900-30	2-023-001
S-190*		
S-541*		
SN-529*		
S-529*		
S-290*		

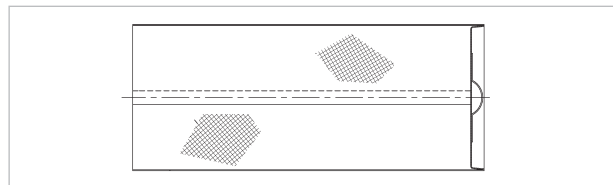

Vessel Part No	Replacement Screen Cartridge	Replacement Gasket
S-579*	3-010-301	2-023-001

OIL LEVEL REGULATORS

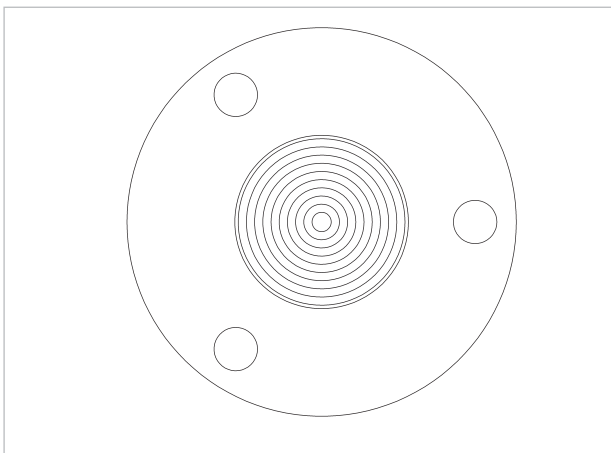

Part No	Description
2-020-006	Reflex Lens Sight Glass
S81-3-125	O-ring
2-023-003	Quad-ring
A4480	Standard Seal Kit (note 1)

Note 1. This is the standard seal kit supplied with each S-95 series regulator. It includes bolts, nuts, quad and O-rings along with a special sandwich piece and O-ring for sealing a Bitzer 4-bolt sight glass.

OIL RESERVOIRS

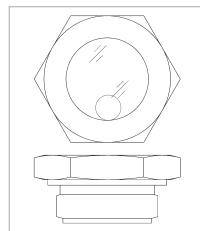

Old style Sight Glass
3-020-011 (1.25 A/F Hex) O-ring S81-3-213
Note: This sight glass design was superseded by part no 3-020-079 in 2003

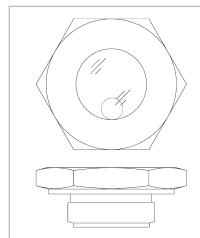

New style Sight Glass
3-020-079 (1.50 A/F Hex) O-ring S81-3-123

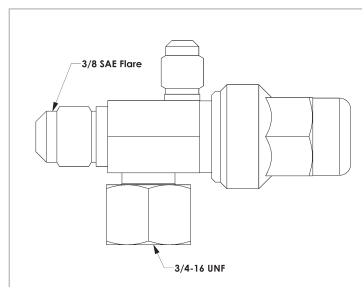

3/8 SAE Flare Rotalock Valve 2-030-122
Teflon seal Gasket A8604

REPLACEMENT COMPONENTS

ELECTRO-MECHANICAL OIL LEVEL REGULATORS

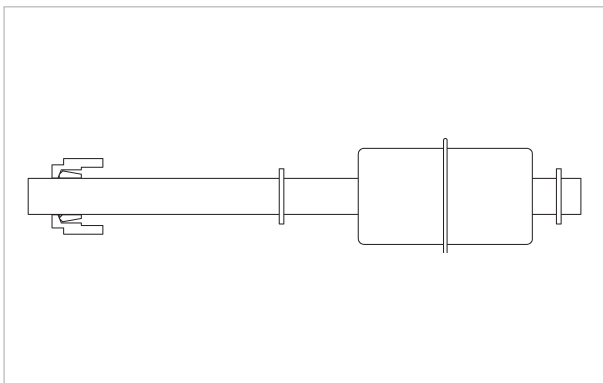

S-9030/S9040 Float Switch Kit (part no 3-044-016)

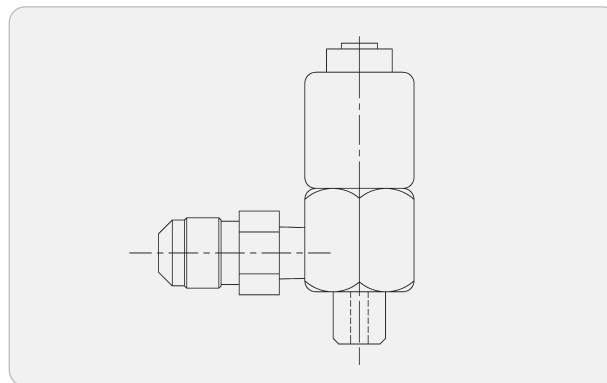

S-9030/S9040 Solenoid Valve Kit (part no 3-044-017)

Part No	Description	Regulator models
3-044-016	Float switch kit	S9030/40
3-044-017	Solenoid valve kit	S9030/40
SG-1006	Sight Glass-Clear	S9040
SG-1106	Sight Glass-Reflex	S9040

ACCESSORIES

HEAT ELEMENTS

Heat elements add heat to oil separators to prevent migration of refrigerant to the vessel during off cycles of the compressor.

4" diameter heat bands can be installed on the sump of the S-520*, S-190*, S-541*, SN-529*, S-529*, S-290*, S-528* & S-579* series Oil Separators.

Heat elements can also be used on suction line accumulators to warm the oil and allow oil return to the compressor on low temperature applications.



Part No	Vessel Diameter (inch)	Wattage (W)	Volts (V)
S-9101	4	25	110 AC
S-9111	4	25	220 AC
S-9112	6	50	220 AC

MOUNTING CLAMPS FOR Ø6" (152MM) VESSELS

These clamps are suitable for 6" inch diameter High Pressure Reservoirs.

The clamping range is 148 to 154 mm diameter and the clamping nuts and bolts are supplied in loose form.

The metal clamp parts are made from galvanised steel and have a sound absorption lining.

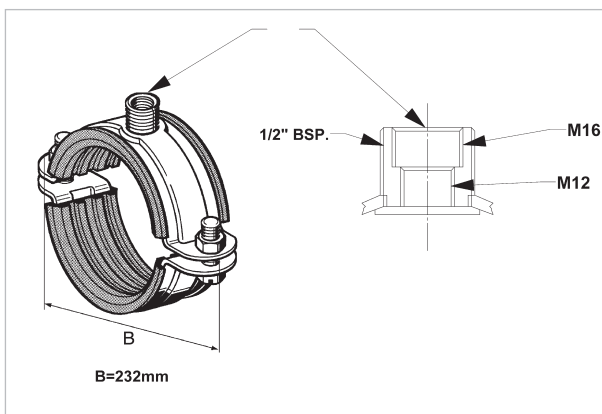

Part No. A4494

BALL VALVES & BALL VALVES WITH SIGHT GLASS (BVSG)

 ■ BALL VALVE

 ■ BALL VALVE WITH SIGHT GLASS

Applications

Ball valves are used in a wide variety of air conditioning and refrigeration applications. They can be used for both liquid and gas applications. This type of valve is commonly used for isolating purposes. All valves are suitable for CO₂, HCFC and HFC refrigerants along with their associated oils.

The new product combines the traditional ball valve with a sight glass and moisture indicator. A typical location for this combination product is in the liquid refrigerant line. The ball valve is used for isolating purposes; the sight glass for a visual display inside the line and the moisture indicator monitors the moisture content in the system.

Main Features

Construction Features

- Bi-directional flow
- Indicator on stem shows valve position - open or closed
- Positive stem stop ensures precise positioning in the open or closed position
- Blow-out proof stem
- Ball cavity vented to prevent over-pressure
- Vented seal cap
- Schrader valve option
- Mounting pad
- Large clear sight glass (BVSG only)
- Positive colour contrast indicator (BVSG only)
- Plastic protection cap for sight glass supplied as standard (BVSG only)

Sealing integrity features

- Premium quality PTFE ball seals
- Double O-ring stem seal design
- Premium quality neoprene stem O-ring seals
- Neoprene cap seal – acts as a secondary seal
- Hermetically sealed sight glass (BVSG only)

Technical Specification

Allowable operating temperature = -40°C to +120°C

Allowable operating pressure = 0 to 48 barg

(higher pressures available on request)

Materials of Construction

The valve body, valve body adaptor, ball and seal cap are made from brass. The stem is made from plated steel. The pipe extensions are made from copper. The ball seals are made from virgin PTFE, stem O-rings and cap seal from neoprene.

Installation – Main Issues

The valve body must be protected against excessive heat during installation to prevent damage to the seals. Full details are provided in the installation sheet, included with each valve.

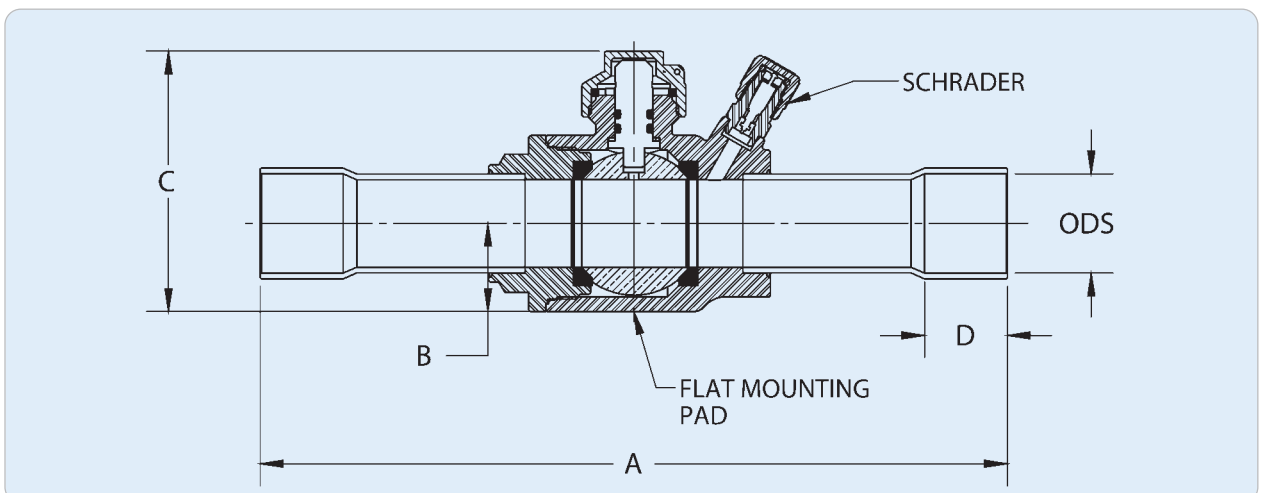

Ball Valves Imperial

Part No		ODS (inch)	Dimensions (mm)					Port Size (mm)	Weight (kg)	MWP (barg)	Kv Value (m ³ /hr)	CE Cat
Standard	Schrader Valve		A	B	C	D	Mounting pad hole thread details -2 off					
907202	937202	1/4	165	16	54	8	8-36 UNF-2B X 20 mm pitch	12.70	0.33	48	1.81	SEP
907203	937203	3/8	165	16	54	8	8-36 UNF-2B X 20 mm pitch	12.70	0.33	48	3.70	SEP
907204	937204	1/2	165	16	54	10	8-36 UNF-2B X 20 mm pitch	12.70	0.33	48	6.02	SEP
907205	937205	5/8	165	16	54	13	8-36 UNF-2B X 20 mm pitch	12.70	0.33	48	11.95	SEP
907306	937306	3/4	184	21	67	16	8-36 UNF-2B X 32 mm pitch	19.05	0.62	48	18.06	SEP
907307	937307	7/8	184	21	67	19	8-36 UNF-2B X 32 mm pitch	19.05	0.64	48	26.06	SEP
907409	937409	1 1/8	216	25	76	23	10-32 UNF-2B X 40 mm pitch	25.40	0.95	48	52.72	SEP
907511	937511	1 3/8	235	31	94	25	10-32 UNF-2B X 48 mm pitch	31.75	1.52	48	73.27	Cat I
907613	937613	1 5/8	254	39	109	28	1/4"-28 UNF-2B X 60 mm pitch	38.10	2.44	48	182.32	Cat I
907617	937617	2 1/8	289	47	132	34	1/4"-28 UNF-2B X 75 mm pitch	50.80	4.58	48	245.10	Cat I
907721	937721	2 5/8	327	47	132	37	1/4"-28 UNF-2B X 75 mm pitch	50.80	5.04	48	204.68	Cat I
907721FP	937721FP	2 5/8	365	60	154	37	1/4"-28 UNF-2B X 75 mm pitch	63.50	8.73	48	258.86	Cat I
907725	937725	3 1/8	365	60	154	42	1/4"-28 UNF-2B X 75 mm pitch	63.50	8.73	48	278.64	Cat I
907825FP	-	3 1/8	420	72	178	43	5/16-24 UNF-2B X 104 mm pitch	80.00	18.20	48	361.20	Cat I
907829	-	3-5/8	420	72	178	43	5/16-24 UNF-2B X 104 mm pitch	80.00	18.20	48	439.46	Cat I
907833	-	4-1/8	420	72	178	56	5/16-24 UNF-2B X 104 mm pitch	80.00	18.20	48	447.20	Cat I

Ball Valves Metric

Part No		ODS (mm)	Dimensions (mm)					Port Size (mm)	Weight (kg)	MWP (barg)	Kv Value (m ³ /hr)	CE Cat
Standard	Schrader Valve		A	B	C	D	Mounting pad hole thread details -2 off					
907206M	937206M	6	165	16	54	8	8-36 UNF-2B X 20 mm pitch	12.70	0.33	48	1.81	SEP
907210M	937210M	10	165	16	54	8	8-36 UNF-2B X 20 mm pitch	12.70	0.33	48	3.70	SEP
907212M	937212M	12	165	16	54	10	8-36 UNF-2B X 20 mm pitch	12.70	0.33	48	6.02	SEP
907205	937205	16	165	16	54	13	8-36 UNF-2B X 20 mm pitch	12.70	0.33	48	11.95	SEP
907318M	937318M	18	184	21	67	17	8-36 UNF-2B X 32 mm pitch	19.05	0.62	48	18.06	SEP
907307	937307	22	184	21	67	20	8-36 UNF-2B X 32 mm pitch	19.05	0.64	48	26.06	SEP
907428M	937428M	28	216	25	76	24	10-32 UNF-2B X 40 mm pitch	25.40	0.95	48	52.72	SEP
907511	937511	35	235	31	94	25	10-32 UNF-2B X 48 mm pitch	31.75	1.52	48	73.27	Cat I
907642M	937642M	42	254	39	109	28	1/4"-28 UNF-2B X 60 mm pitch	38.10	2.44	48	182.32	Cat I
907617	937617	54	289	48	132	35	1/4"-28 UNF-2B X 75 mm pitch	50.80	4.58	48	245.10	Cat I
907764M	937764M	64	327	48	132	35	1/4"-28 UNF-2B X 75 mm pitch	50.80	5.04	48	204.68	Cat I
907764MFP	937764MFP	64	365	60	154	35	1/4"-28 UNF-2B X 75 mm pitch	63.50	8.73	48	258.86	Cat I
907776M	937776M	76	365	60	154	43	1/4"-28 UNF-2B X 75 mm pitch	63.50	8.73	48	278.64	Cat I
907889M	-	89	420	72	178	43	5/16-24 UNF-2B X 104 mm pitch	80.00	18.20	48	361.20	Cat I
9078108M	-	108	420	72	178	58	5/16-24 UNF-2B X 104 mm pitch	80.00	18.20	48	439.46	Cat I

Ball Valve with Sight Glass

Part No		ODS (inch)	ODS (mm)	Dimensions (mm)					Port Size (mm)	Weight (kg)	MWP (barg)	Kv Value (m ³ /hr)	CE Cat
Standard	Schrader Valve			A	B	C	D	Mounting pad hole thread details -2 off					
907202SG	937202SG	1/4	–	185	16	55	8	8-36 UNF-2B X 20 mm pitch	12.70	0.42	48	1.81	SEP
907203SG	937203SG	3/8	–	185	16	55	8	8-36 UNF-2B X 20 mm pitch	12.70	0.42	48	3.70	SEP
907204SG	937204SG	1/2	–	185	16	55	10	8-36 UNF-2B X 20 mm pitch	12.70	0.42	48	6.02	SEP
907205SG	937205SG	5/8	16	185	16	55	13	8-36 UNF-2B X 20 mm pitch	12.70	0.42	48	11.95	SEP
907306SG	937306SG	3/4	–	211	21	67	19	8-36 UNF-2B X 32 mm pitch	19.05	0.80	48	18.06	SEP
907307SG	937307SG	7/8	22	211	21	67	20	8-36 UNF-2B X 32 mm pitch	19.05	0.80	48	26.06	SEP
907409SG	937409SG	1 1/8	–	237	26	76	24	10-32 UNF-2B X 40 mm pitch	25.40	1.20	48	52.72	SEP

Moisture Colour Table

Refrigerant	Moisture content (parts per million)			
	Temp (°C)	Indicator Colour		
		Green	Chartreuse	Yellow
R404A	24	below 20	20-100	above 100
	38	below 35	35-130	above 130
	52	below 45	45-200	above 200
R410A	24	below 20	20-100	above 100
	38	below 30	30-120	above 120
	52	below 50	50-150	above 150
R134a	24	below 30	30-90	above 90
	38	below 50	50-120	above 120
	52	below 70	70-150	above 150
R22	24	below 20	20-85	above 85
	38	below 30	30-90	above 90
	52	below 45	45-110	above 110
R744	24	below 15	15-80	above 80
	38	below 20	20-90	above 90
	52	below 35	35-110	above 110

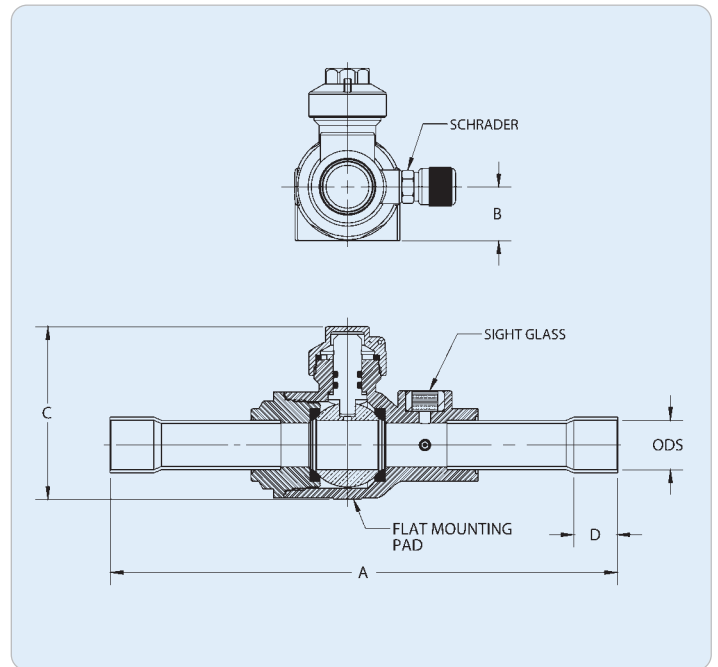

CHECK VALVES

The function of a check valve is to allow fluid flow in one direction only.

The Henry Technologies range includes both lift and in-line check valves. The lift check valves are series 205, 116 and NRV. The in-line check valves are series 120.

Applications

Henry Technologies check valves are suitable for HCFC and HFC refrigerants, along with their associated oils.

A typical application is to install a check valve downstream of an oil separator. This prevents condensed liquid refrigerant returning down the discharge line and into the separator.

The 120 series check valves are not suitable for discharge lines of reciprocating compressors.

Main features

- Robust design
- Flow direction arrow
- Quiet and efficient operation
- Minimum opening pressure
- Models with copper extensions – NRV E & 120 series

Technical Specification

Allowable operating pressure = 0 to 34.5 barg (except 116H & 120H series)

Allowable operating pressure = 0 to 45 barg (120H series)

Allowable operating pressure = 0 to 60 barg (116H series)

Allowable operating temperature:-

116 series = -40°C to +149°C

120 series = -29°C to +100°C

205 series = -29°C to +149°C

NRV series = -40°C to +120°C

Typically, Henry check valves will start to open at 0.034 barg and be fully open at 0.34 barg pressure differential.



Materials of Construction

The valve body for the 205 series is made from cast bronze. All other check valve bodies are made from brass. All pistons are made from brass. Springs are made from stainless steel. The seat seal material is PTFE for the 116, 205 and NRV series. The seat seal material is neoprene for the 120 series.

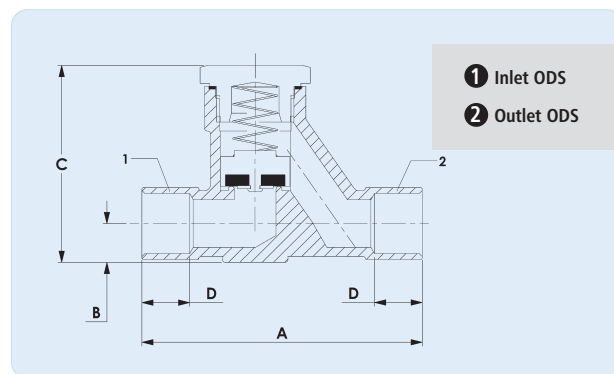

116 SERIES

Part No	Conn Size (inch)	Dimensions (mm)				Weight (kg)	Kv (m ³ /hr)	CE Cat
		A	B	C	D			
116003	3/8 ODS	75	10	52	8	0.24	1.38	SEP
116003H	3/8 ODS	75	10	52	8	0.24	1.38	SEP
116004	1/2 ODS	75	10	52	10	0.23	1.90	SEP
116004H	1/2 ODS	75	10	52	10	0.23	1.90	SEP
116005	5/8 ODS	75	10	52	13	0.22	2.25	SEP
116005H	5/8 ODS	75	10	52	13	0.22	2.25	SEP
116007	7/8 ODS	99	16	75	22	0.92	3.10	SEP

Part No	Conn Size (inch)	Dimensions (mm)			Weight (kg)	CE Cat
		A	B	C/HEX		
120-3/8	3/8 ODS	153	8	21	0.16	SEP
120H-3/8	3/8 ODS	153	8	21	0.16	SEP
120-1/2	1/2 ODS	158	10	32	0.25	SEP
120-5/8	5/8 ODS	163	13	32	0.28	SEP
120-7/8	7/8 ODS	189	19	38	0.53	SEP
120H-7/8	7/8 ODS	189	19	38	0.53	SEP

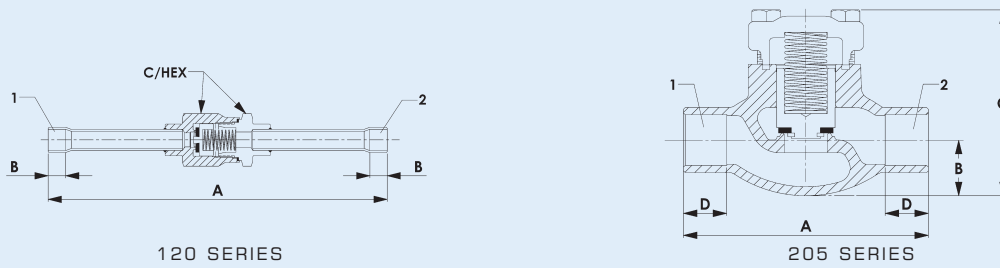

- 1 Inlet ODS
- 2 Outlet ODS

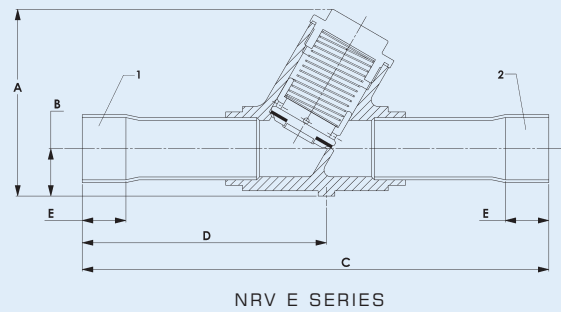
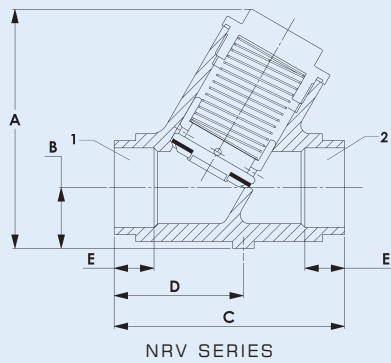

Part No	Conn Size (inch)	Dimensions (mm)				Weight (kg)	Kv (m ³ /hr)	CE Cat
		A	B	C	D			
205-7/8	7/8 ODS	108	25	80	19	1.10	4.58	SEP
205-1 1/8	1 1/8 ODS	124	29	98	24	2.02	6.40	SEP
205-1 3/8-CE	1 3/8 ODS	137	32	108	25	2.64	8.90	Cat I
205-1 5/8-CE	1 5/8 ODS	165	38	129	29	4.43	11.50	Cat I
205-2 1/8-CE	2 1/8 ODS	216	51	157	38	7.75	19.03	Cat I
205-2 5/8-CE	2 5/8 ODS	279	57	183	43	12.50	31.57	Cat I

Part No	Conn Size (inch)	Dimensions (mm)					Weight (kg)	Kv (m ³ /hr)	CE Cat
		A	B	C	D	E			
NRV14	7/8 ODS	78	20	70	38	11	0.60	5	SEP
NRV18	1 1/8 ODS	78	20	70	38	11	0.53	8.5	SEP
NRV22-CE	1 3/8 ODS	106	27	102	57	17	1.30	13.5	Cat I
NRV26-CE	1 5/8 ODS	106	27	102	57	17	1.20	16	Cat I

Part No	Conn Size (inch)	Dimensions (mm)					Weight (kg)	Kv (m ³ /hr)	CE Cat
		A	B	C	D	E			
NRV14E	7/8 ODS	78	20	191	98	19	0.77	5.0	SEP
NRV18E	1 1/8 ODS	78	20	225	116	23	0.79	8.5	SEP
NRV22E-CE	1 3/8 ODS	106	27	264	138	25	1.70	13.5	Cat I
NRV26E-CE	1 5/8 ODS	106	27	270	138	28	1.60	16.0	Cat I

Installation – Main issues

1. Valves must be installed in accordance with the flow direction arrow.
2. The valve bodies and valve internals must be protected against damage during brazing. Full instructions are given in the Product Instruction Sheet, included with each valve.
3. Series 116 valves can be installed in any position except bonnet down. This is the same for 205 series up to 1 3/8" size. For larger sizes, the bonnet must be positioned upwards. The bonnet of the NRV series should be positioned upwards. For all models, the recommended bonnet position is upwards.
4. Discharge check valves should be positioned as far from the compressor as possible.

MAGNI-CHEK VALVES™



How It Works

A Magni-Chek Valve™ uses magnetic attraction to return the valve plate to its seat rather than spring pressure. A conventional check valve requires an increase in pressure to force the valve plate off its seat thus causing an increase in pressure drop. The Magni-Chek Valve™ has a decreasing force to move it away from its seat. The further it travels the more the magnetic attraction diminishes resulting in a decrease in pressure drop.

Applications

Magni-Chek Valves™ can be installed in discharge, liquid and suction lines where it is necessary to ensure fluid flow only occurs in one direction. The valves are suitable for use with HCFC, HFC and CO₂ refrigerants along with their associated oils.

Main Features

- Maximum flow and minimum pressure drop
- Can be installed in any orientation
- Cost effective
- 30 mesh strainer – extends valve service life
- Optimised seat material with a neoprene-coated valve plate
- Suitable for a wide range of applications

Technical Specification

Allowable operating temperature = -40°C to + 120°C
 Allowable operating pressure = Minimum 0 barg, Maximum as per table below
 Refer to the table for maximum operating pressure differential (MOPD)

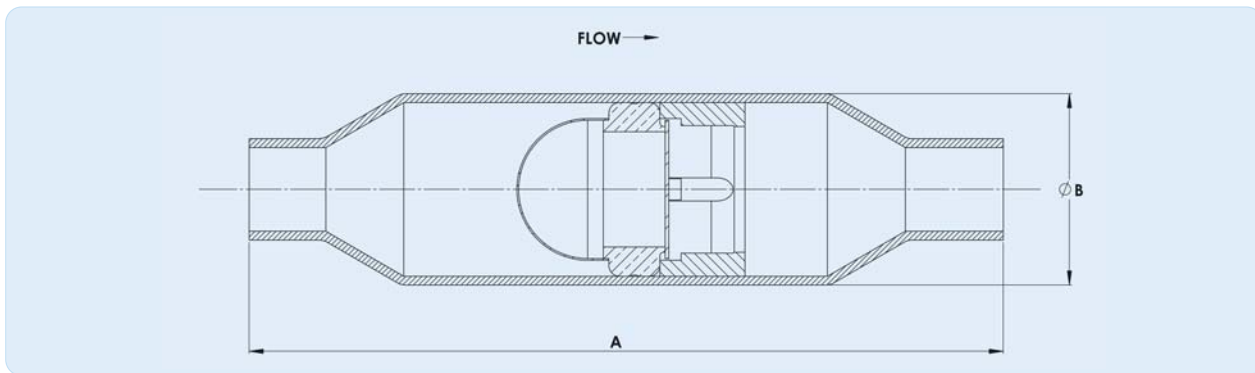

Magni-Chek Valves™

Part No	Model No	Conn Size (inch)	Dimensions (mm)		Kv (m ³ /hr)	MOPD (Bar)	MWP (Barg)	Weight (kg)	CE Cat
			A	B					
F6306	MS-4	1/4	102	22	0.47	20.7	55.2	0.10	SEP
F6307	MS-6	3/8	102	22	0.99	20.7	55.2	0.10	SEP
F6308	MS-8	1/2	127	29	2.67	20.7	48.3	0.17	SEP
F6309	MS-10	5/8	127	29	2.98	20.7	48.3	0.17	SEP
F6310	MS-12	3/4	178	41	5.56	17.2	48.3	0.43	SEP
F6311	MS-14	7/8	178	41	7.58	17.2	48.3	0.42	SEP
F6312	MS-18	1 1/8	213	54	13.19	13.8	48.3	0.75	SEP
F6313	MS-22	1 3/8	240	67	16.26	13.8	48.3	1.27	Cat I
F6314	MS-26	1 5/8	267	80	27.78	13.8	48.3	1.80	Cat I
F6315	MS-34	2 1/8	305	92	48.27	13.8	48.3	1.80	Cat I
F6316	MS-42	2 5/8	330	105	64.76	6.9	44.8	3.70	Cat I
F6085	MS-50	3 1/8	330	105	64.76	6.9	44.8	3.70	Cat I

GLOBE VALVES

Globe Valves are used for isolating purposes. The Henry Technologies range includes two versions; with and without copper extensions.

Applications

Globe valves are used in both low and high side applications.

The valves are suitable for HCFC and HFC refrigerants along with their associated oils.

Main features

- Angled body combines compact design with low pressure drop
- Vented seal cap
- Non rising stem
- Flow direction arrow on valve body
- Premium quality neoprene O-ring seals

Technical Specification

Allowable operating pressure = 0 to 34.5 barg

Allowable operating temperature = -40°C to +120°C

Materials of Construction

The valve body, bonnet and seal cap are made from brass. The stem is made from plated steel. The seat seal is made from nylon. The ODS extensions for the "E" models are made from copper.



Installation – Main issues

1. During brazing, the valve must be protected against excessive heat to prevent damage to the machined bores and seals. Full instructions are given in the Product Instruction Sheet, included with each valve.

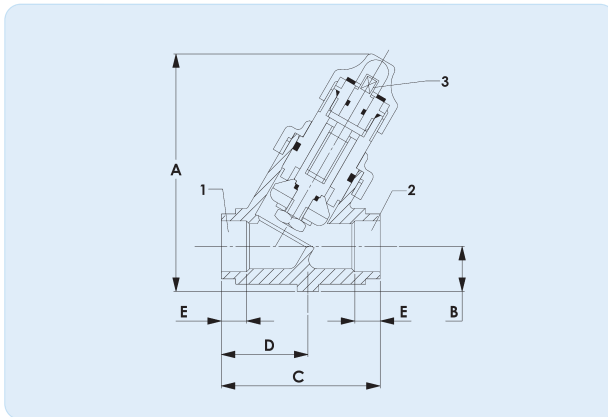

RLV SERIES

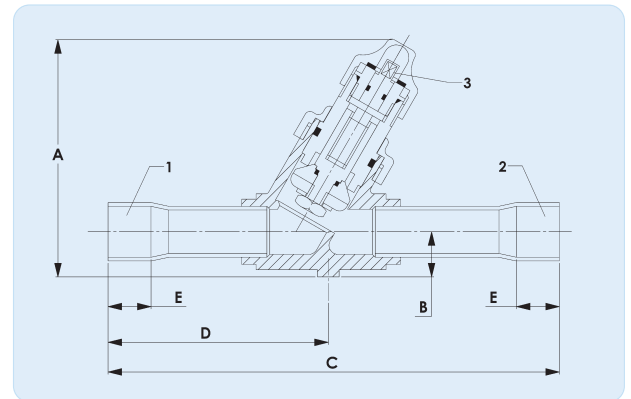

RLV E SERIES

- 1 Inlet ODS
- 2 Outlet ODS
- 3 6.4mm square drive

Part No	Conn Size (inch)	Dimensions (mm)					Weight (kg)	Kv (m ³ /hr)	CE Cat
		A	B	C	D	E			
RLV14	7/8 ODS	110	20	70	38	11	0.87	6.5	SEP
RLV18	1 1/8 ODS	110	20	70	38	11	0.80	11	SEP
RLV22-CE	1 3/8 ODS	134	27	102	58	17	1.75	18.1	Cat I
RLV26-CE	1 5/8 ODS	134	27	102	58	17	1.60	22	Cat I

Part No	Conn Size (inch)	Dimensions (mm)					Weight (kg)	Kv (m ³ /hr)	CE Cat
		A	B	C	D	E			
RLV14E	7/8 ODS	110	20	188	97	19	1.06	6.5	SEP
RLV18E	1 1/8 ODS	110	20	225	116	23	1.08	11	SEP
RLV22E-CE	1 3/8 ODS	134	27	265	138	25	2.10	18.1	Cat I
RLV26E-CE	1 5/8 ODS	134	27	271	143	28	2.10	22	Cat I

PACKLESS VALVES

Packless valves are so called due to the absence of a packed gland for stem sealing. Instead, metal diaphragms are used to isolate the stem from the fluid area.

The Henry Technologies range includes three versions: 'Golden Bantam', 'Standard' and '2100B & 2111B'.

Applications

Henry Technologies packless valves are used in a variety of air conditioning and refrigeration applications for isolating, flow control, charging and purging purposes.

The valves are suitable for HCFC and HFC refrigerants, along with their associated oils. The 2100B & 2111B series are suitable for HCFC, HFC and CO₂ refrigerants along with their associated oils.

Main features

- Robust design
- Compact
- Heat stabilised nylon seat ring for positive shut-off
- Positive back-seating with valve in open position
- Raised seat reduces debris induced sealing issues
- Large diameter diaphragm for greater lift, better flow and longer life
- Hermetic seal between bonnet, diaphragms and body
- Suitable for vacuum applications

Technical Specification

Allowable working pressure = Vacuum up to 34.5 barg
 Allowable working pressure = Vacuum up to 42 barg (2100B & 2111B)
 Allowable working temperature = -29°C to +135°C



Materials of Construction - Golden Bantam series

The valve body, upper stem and bonnet are made from brass. The lower stem/seat ring is made from nylon and the diaphragm set is composed of both phosphor bronze and stainless steel. The valve spring is made from stainless steel. The hand-wheel is made from moulded plastic.

Materials of Construction - Standard series

The valve body and bonnet are made from brass. The lower stem is made from brass for all models except the 629 series, where the material is monel.

The upper stem, stem cap and valve springs are made from stainless steel. The seat ring is made from nylon for all models except the 629 series. These models use a stainless steel seat ring. The diaphragm set is composed of both phosphor bronze and stainless steel. The hand-wheel is made from white metal.

Materials of Construction - 2100B & 2111B series

The valve body, upper stem and bonnet are made from brass. The lower stem/seat ring is made from nylon and the diaphragm is made from stainless steel. The valve spring is made from stainless steel. The hand-wheel is made from moulded plastic.

GOLDEN BANTAM SERIES

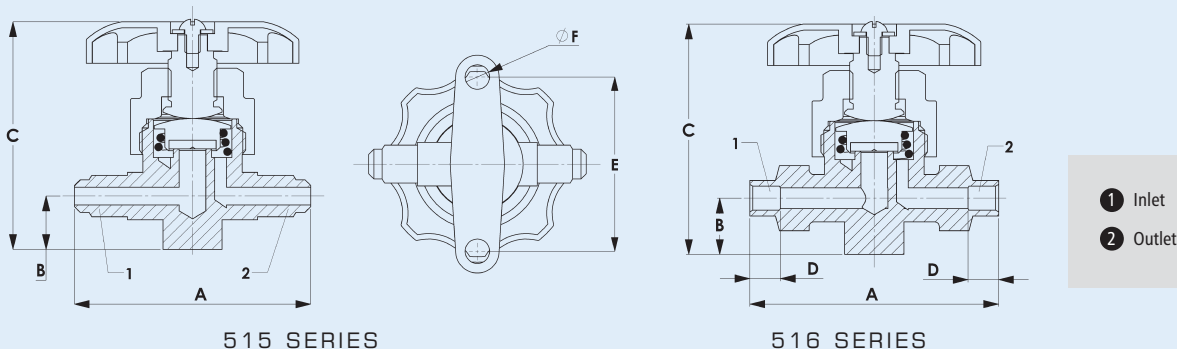

Golden Bantam Valves												
TYPE	Part No	Conn Size (inch)	Dimensions (mm)						Weight (kg)	Kv (m ³ /hr)	CE Cat	
			A	B	C (Open)	D	E	Ø F				
515	5151	1/4 SAE Flare	64	14	65	N/A	51	7	0.28	0.85	SEP	
515	5153	3/8 SAE Flare	67	14	65	N/A	51	7	0.29	1.20	SEP	
516	5161	1/4 ODS	67	14	65	8	51	7	0.29	0.85	SEP	
516	5163	3/8 ODS	67	14	65	10	51	7	0.29	1.20	SEP	

STANDARD SERIES

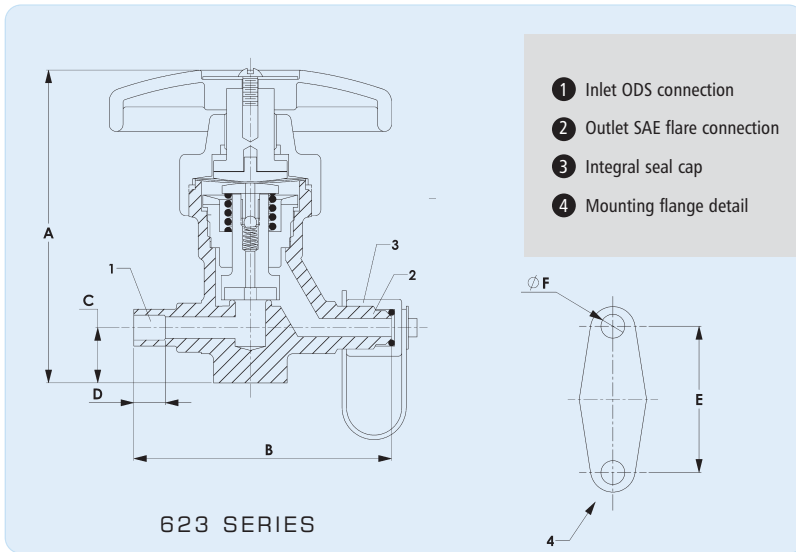

Part No	Conn Size (inch)	Dimensions (mm)						Weight (kg)	CE Cat
		A	B	C	D	E	ØF		
6231N	1/4 ODS x 1/4 SAE Flare	86	67	14	8	41.4	6.9	0.47	SEP
6232N	3/8 ODS x 3/8 SAE Flare	86	67	14	11	41.4	6.9	0.55	SEP
6233N	1/2 ODS x 1/2 SAE Flare	90	83	16	14	44.5	7	0.62	SEP
6234N	5/8 ODS x 5/8 SAE Flare	95	94	19	18	50.8	7	0.65	SEP

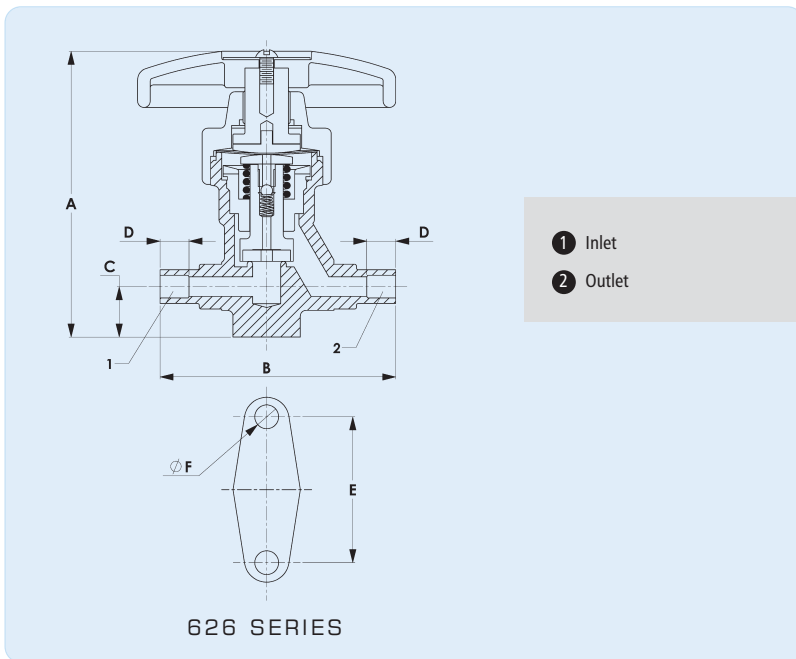

Part No	Conn Size (inch)	Dimensions (mm)						Weight (kg)	CE Cat
		A	B	C	D	E	ØF		
6261N	1/4 ODS	86	67	14	8	41.4	6.9	0.47	SEP
6263N	3/8 ODS	86	67	14	11	41.4	6.9	0.51	SEP
6264N	1/2 ODS	90	80	16	14	44.5	7	0.57	SEP
6265N	5/8 ODS	95	89	19	18	50.8	7	0.65	SEP
6266N	3/4 ODS	127	111	18	19	57.2	8.6	1.42	SEP
6267N	7/8 ODS	137	122	19	22	63.5	10.4	1.6	SEP
6268N	1 1/8 ODS	165	151	24	25	82.6	10.4	2.63	SEP

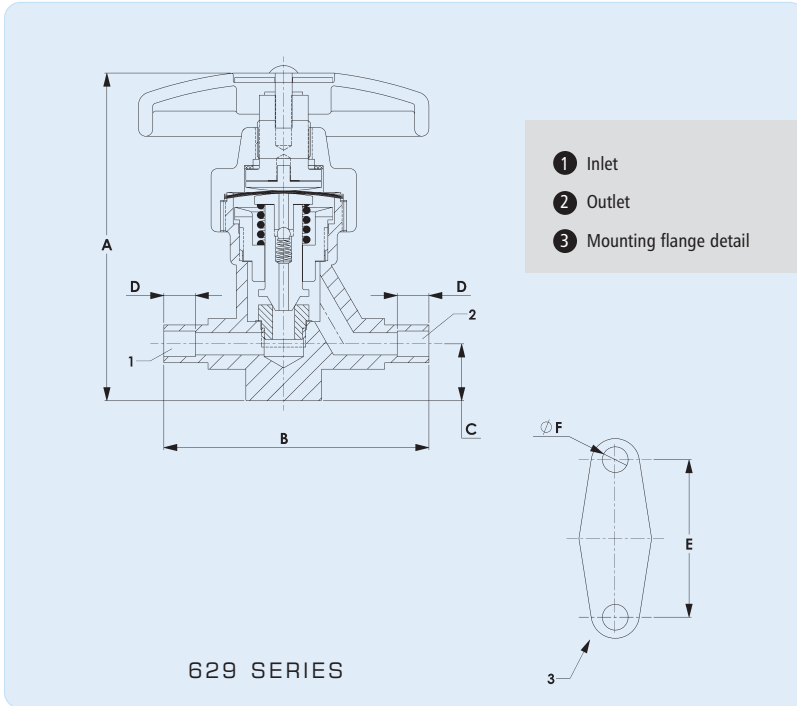

Part No	Conn Size (inch)	Dimensions (mm)						Weight (kg)	CE Cat
		A	B	C	D	E	ØF		
6291N	1/4 ODS	86	67	14	8	41.4	6.9	0.47	SEP
6293N	3/8 ODS	86	67	14	11	41.4	6.9	0.47	SEP
6294N	1/2 ODS	86	67	14	14	41.4	6.9	0.47	SEP
6295N	5/8 ODS	90	86	16	18	44.5	7	0.58	SEP
6297N	7/8 ODS	127	113	18	19	57.2	8.6	1.25	SEP
6298N	1 1/8 ODS	137	122	19	21	63.5	10.3	1.48	SEP

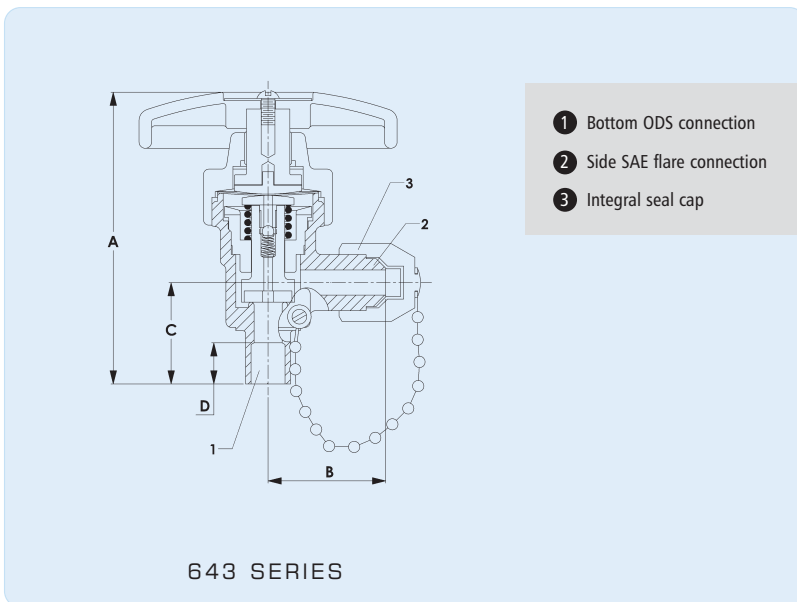

Part No	Conn Size (inch)	Dimensions (mm)				Weight (kg)	CE Cat
		A	B	C	D		
6432N	3/8 ODS X 3/8 SAE Flare	86	33	29	11	0.44	SEP
6433N	1/2 ODS x 1/2 SAE Flare	89	41	30	14	0.6	SEP
6434N	5/8 ODS x 5/8 SAE Flare	97	44	35	18	0.8	SEP

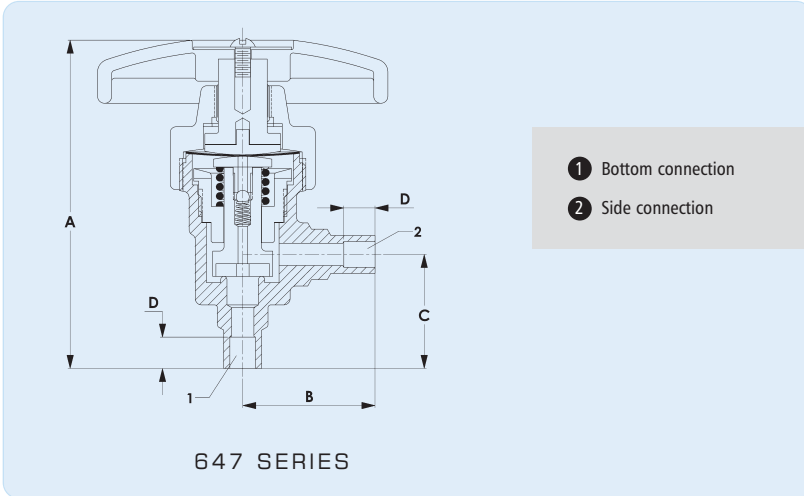

Part No	Conn Size (inch)	Dimensions (mm)				Weight (kg)	CE Cat
		A	B	C	D		
6471N	1/4 ODS	87	33	29	8	0.39	SEP
6473N	3/8 ODS	87	33	29	11	0.4	SEP
6474N	1/2 ODS	90	38	30	14	0.5	SEP
6475N	5/8 ODS	97	38	35	18	0.6	SEP
6476N	3/4 ODS	124	48	36	19	1.19	SEP
6477N	7/8 ODS	137	53	45	22	1.34	SEP
6478N	1 1/8 ODS	165	64	57	25	2.01	SEP

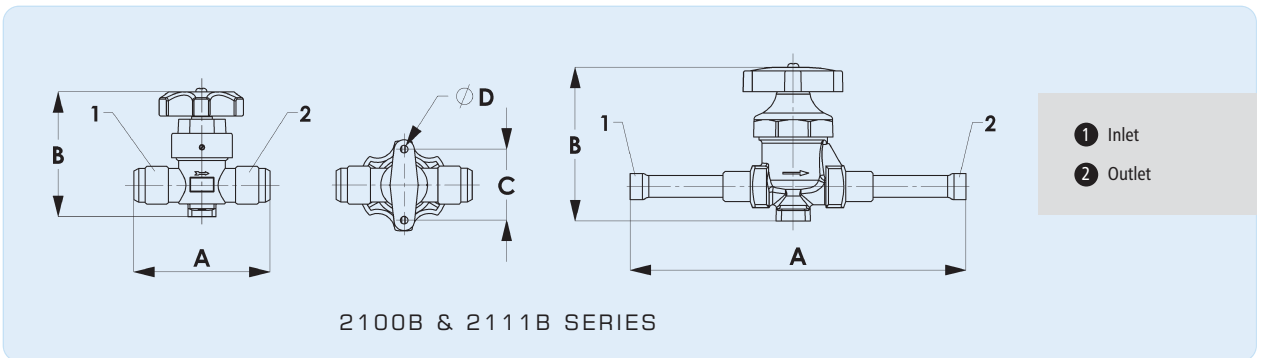

Type	Part No	Conn Size (inch)	Dimensions (mm)				Weight (kg)	Kv (m³/hr)	CE Cat
			A	B (Closed)	C	D			
2100B	2100B-0404	1/4 SAE Flare	58	60	35	4.5	0.18	0.25	SEP
2100B	2100B-0606	3/8 SAE Flare	70	68	38	4.5	0.30	0.80	SEP
2100B	2100B-0808	1/2 SAE Flare	72	68	38	4.5	0.32	1.50	SEP
2100B	2100B-1010	5/8 SAE Flare	78	68	38	4.5	0.32	2.20	SEP
2100B	2100B-1212	3/4 SAE Flare	95	80	50	4.5	0.80	2.90	SEP
2111B	2111B-0404	1/4 ODS	120	60	35	4.5	0.18	0.25	SEP
2111B	2111B-0606	3/8 ODS	130	68	38	4.5	0.32	0.80	SEP
2111B	2111B-0808	1/2 ODS	138	68	38	4.5	0.35	1.50	SEP
2111B	2111B-1010	5/8 ODS	158	68	38	4.5	0.38	2.20	SEP
2111B	2111B-1212	3/4 ODS	178	80	50	4.5	0.70	2.90	SEP

Additional Information

- For series 623*, 626*, 643* and 647*: Valves are bi-directional up to 24.1 barg. Above this pressure, the direction of flow should be with the inlet under the valve seat.
- For series 629*: For hand expansion or throttling service, the direction of flow should be with the inlet under the valve seat.

Installation – Main Issues

- Valves must be protected against excessive heat when installing to prevent damage to the seals. Full instructions are given in the Product Instruction Sheet, included with each valve.

PACKED SHUT-OFF VALVES

Packed valves are so called as the stem is sealed via a packed gland. The Henry Technologies range incorporates the 7, 926, 927 and 203 series.

Applications

Henry Technologies packed valves are used in a variety of air conditioning and refrigeration applications for isolating, flow control, charging and purging purposes.

All valves are suitable for HCFC and HFC refrigerants, along with their associated oils.

The 7761 to 7775 models are also suitable for ammonia.

Main features

- Wide range of inlet and outlet connection sizes
- Compact
- Back-seating options allow packing replacement in-situ

Technical Specification

Allowable operating pressure = 0 to 34.5 barg (77-B & 78 series)

Allowable operating pressure = 0 to 48.0 barg (92 brass series)

Allowable operating pressure = 0 to 31.0 barg (203 series)

Allowable operating pressure = 0 to 69.0 barg (77 steel series)

Allowable operating temperature = -29°C to +149°C
(All valves except 203 series)

Allowable operating temperature = -40°C to +163°C
(203 series only)

Materials of Construction

For 77-B, 78 and 92 brass series:-

The valve body is made from brass. The stem is made from plated steel. A metal-to-metal seat seal is used. A graphite compound is used for the packing gland. The seal cap is made from moulded plastic.

For 203 brass series:-

The valve body and bonnet are made from bronze and brass respectively. The stem is made from stainless steel. The seat seal material is PTFE. A graphite compound is used for the packing gland. The seal cap is made from moulded plastic.

For 77 steel series:-

The valve body is made from steel. The stem is made from plated steel. A metal-to-metal seat seal is used. A graphite compound is used for the packing gland. The seal cap is made from moulded plastic or steel.



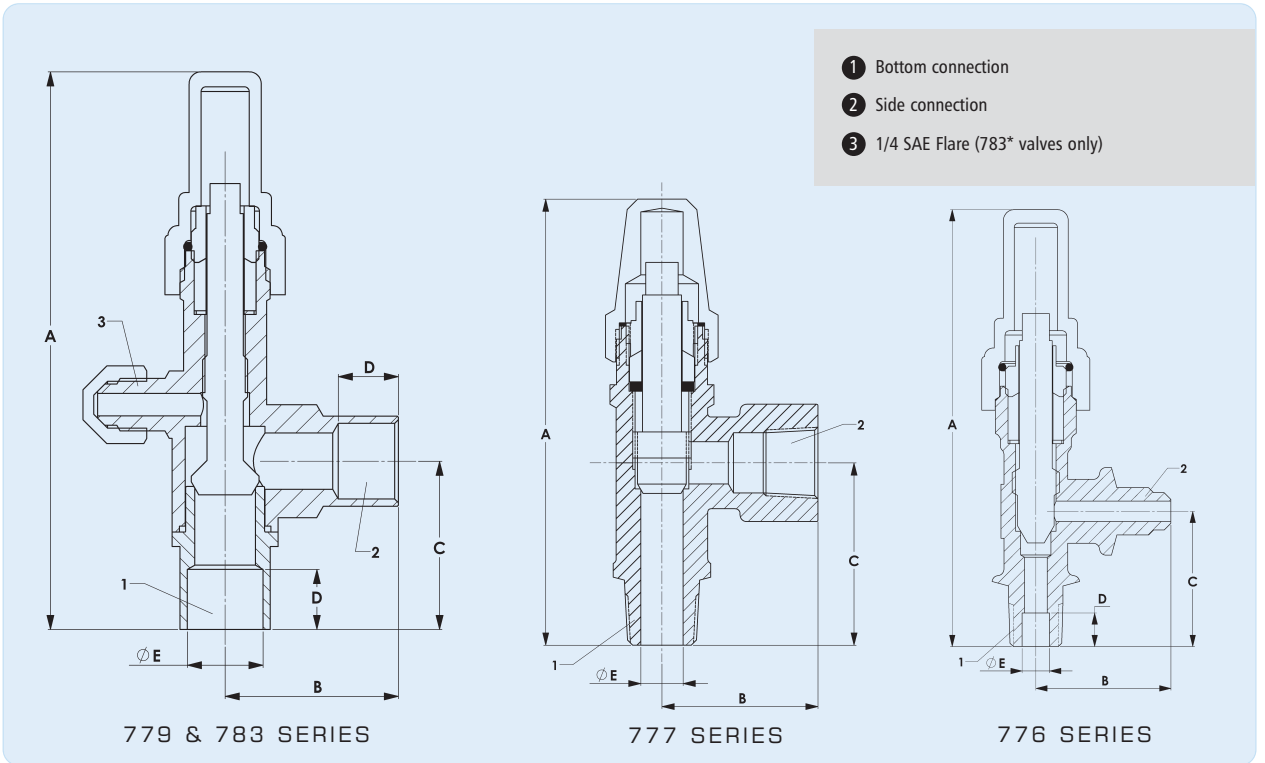

	Part No	Conn Size (inch)		Dimensions (mm)				Ø E (inch)	Weight (kg)	MWP (barg)	CE Cat
		Bottom	Side	A	B	C	D				
Non-backseating	7761-B	1/4 MPT	1/4 SAE Flare	98	32	32	8	1/4 ODS	0.15	34.5	SEP
	7771-B	1/4 MPT	1/4 FPT	98	32	32	8	5/16 ODS	0.15	34.5	SEP
	7763-B	1/4 MPT	3/8 SAE Flare	98	32	32	8	5/16 ODS	0.14	34.5	SEP
	7764-B	3/8 MPT	1/4 SAE Flare	98	32	32	8	3/8 ODS	0.15	34.5	SEP
	7766-B	3/8 MPT	3/8 SAE Flare	98	32	32	8	3/8 ODS	0.14	34.5	SEP
	7767-B	3/8 MPT	1/2 SAE Flare	98	32	32	8	3/8 ODS	0.15	34.5	SEP
	7768-AB	1/2 MPT	3/8 SAE Flare	99	33	35	10	1/2 ODS	0.32	34.5	SEP
	7768-B	1/2 MPT	5/8 SAE Flare	99	41	35	10	1/2 ODS	0.34	34.5	SEP
Backseating	7792-B	1/2 MPT	1/2 SAE Flare	122	37	40	N/A	1/2 ODS	0.31	34.5	SEP
	7793-B	1/2 MPT	5/8 SAE Flare	125	39	43	N/A	1/2 ODS	0.34	34.5	SEP
	7830*	3/8 ODS	3/8 ODS	110	33	29	8	3/8 ODS	0.24	34.5	SEP
	7831*	1/2 ODS	1/2 ODS	114	33	33	10	1/2 ODS	0.25	34.5	SEP
	7832*	5/8 ODS	5/8 ODS	117	32	36	13	5/8 ODS	0.26	34.5	SEP
	7833*	7/8 ODS	7/8 ODS	138	45	43	19	7/8 ODS	0.47	34.5	SEP
	7834*	1 1/8 ODS	1 1/8 ODS	180	45	51	24	1 1/8 ODS	0.79	34.5	SEP
	7835-CE*	1 3/8 ODS	1 3/8 ODS	188	51	57	25	1 3/8 ODS	1.10	34.5	Cat I
7836-CE*	1 5/8 ODS	1 5/8 ODS	232	54	62	28	1 5/8 ODS	1.60	34.5	Cat I	

* 1/4 SAE Flare above backseat

	Part No	Conn Size (inch)		Dimensions (mm)				Weight (kg)	MWP (barg)	CE Cat	
		Bottom	Side	A	B	C	D				
Non-backseating	7761	1/4 MPT	1/4 SAE Flare	98	32	32	N/A	8	0.14	69	SEP
	7771	1/4 MPT	1/4 FPT	98	32	32	N/A	8	0.15	69	SEP
	7772	1/4 FPT	1/4 FPT	98	32	32	N/A	8	0.15	69	SEP
	7773	3/8 MPT	3/8 FPT	109	38	44	N/A	10	0.38	69	SEP
	7774	3/8 FPT	3/8 FPT	109	38	44	N/A	10	0.38	69	SEP
	7775	1/2 MPT	1/2 FPT	109	38	44	N/A	12	0.39	69	SEP

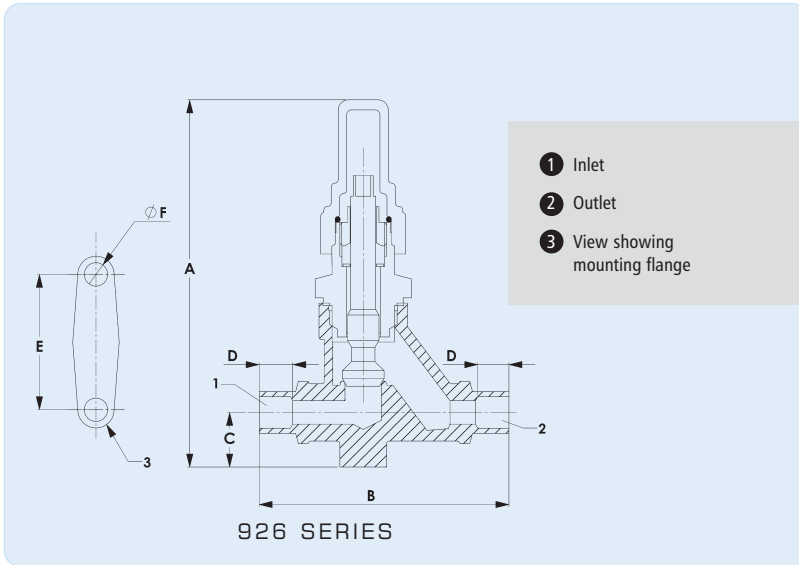

Backseating	Part No	Conn Size (inch)	Dimensions (mm)					ØF	Weight (kg)	MWP (barg)	CE Cat
			A	B	C	D	E				
	9261	1/4 ODS	112	70	17	8	41.4	7.1	0.36	48	SEP
	9263	3/8 ODS	112	76	17	10	41.4	7.1	0.36	48	SEP
	9264	1/2 ODS	112	81	17	11	41.4	7.1	0.36	48	SEP
	9265	5/8 ODS	114	86	18	18	41.4	7.1	0.36	48	SEP

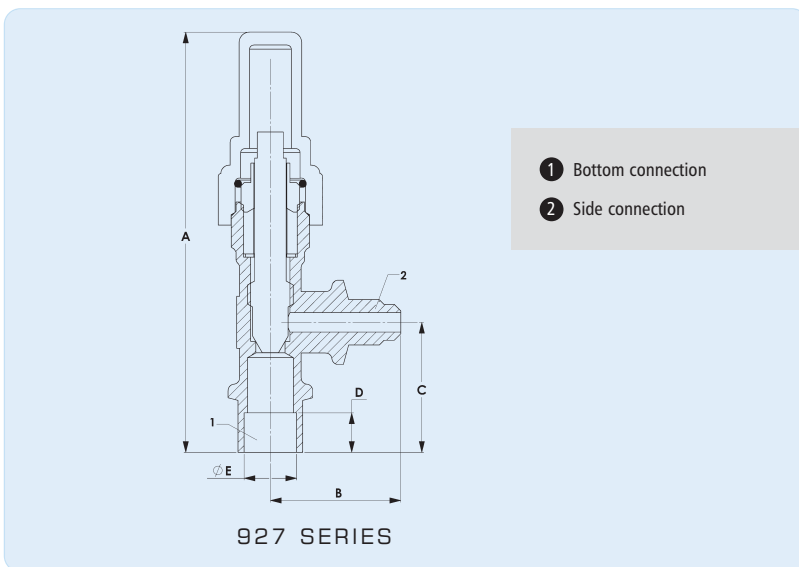

Non-backseating	Part No	Conn Size (inch)		Dimensions (mm)				E (inch)	Weight (kg)	MWP (barg)	CE Cat
		Bottom	Side	A	B	C	D				
	9270	1/4 ODS	1/4 SAE Flare	98	32	32	8	1/4 ODS	0.15	48	SEP
	9271	3/8 ODS	1/4 SAE Flare	98	32	32	8	3/8 ODS	0.15	48	SEP
	9272	3/8 ODS	3/8 SAE Flare	98	32	32	8	3/8 ODS	0.21	48	SEP
	9273	1/2 ODS	1/4 SAE Flare	98	32	32	10	1/2 ODS	0.15	48	SEP
	9274	1/2 ODS	3/8 SAE Flare	98	32	32	10	1/2 ODS	0.21	48	SEP

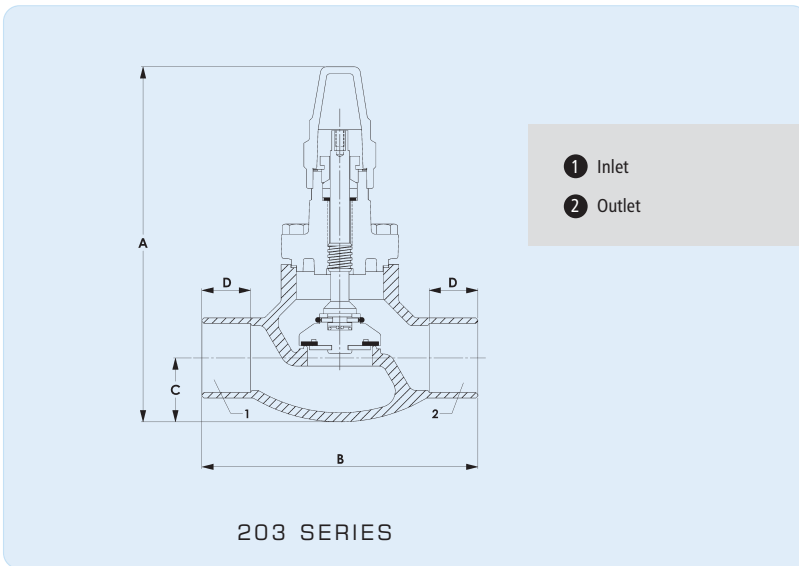

	Part No	Conn Size (inch)	Dimensions (mm)				Weight (kg)	Kv (m³/hr)	MWP (barg)	CE Cat
			A	B	C	D				
Backseating	2030-AA	7/8 ODS	143	108	25	19	1.36	4.58	34.5	SEP
	2030-BA	1 1/8 ODS	149	124	29	24	2.13	6.40	34.5	SEP
	2031-CE	1 3/8 ODS	222	137	32	25	3.34	9.34	34.5	Cat I
	2032-CE	1 5/8 ODS	252	165	38	29	4.73	11.50	34.5	Cat I
	2033-CE	2 1/8 ODS	270	216	51	38	7.59	19.03	34.5	Cat I
	2034-CE	2 5/8 ODS	303	279	58	43	12.78	31.40	34.5	Cat I
	2035-CE	3 1/8 ODS	337	305	67	44	20	44.98	34.5	Cat I

Installation – Main issues

1. Valves must be protected from heat damage during installation. Full instructions are given in the Product Instruction Sheet, included with each valve.

POSITIVE OIL EXCHANGE VALVES

The Positive Oil Exchange Valve is an efficient and timesaving servicing tool for the removal and replacement of compressor crankcase oil.

Applications

The valves are primarily intended for semi-hermetic type compressors. The valves are suitable for HCFC and HFC refrigerants, along with their associated oils.

Main features

- Easy to install
- Reduces service time and cost
- Designed for oil charge and drain
- Pressure gauge connection with Schrader valve
- Full port valve for fast charging and draining
- Designed to be permanently fitted to the compressor, for future servicing

Technical Specification

Allowable operating pressure = 0 to 34.5 barg

Allowable operating temperature = -29°C to +120°C

Materials of Construction

The valve body is made from brass and the stem from plated steel. The stem seal cap is made from moulded plastic. The SAE Flare and Schrader port seal caps are made from nylon. The draw pipe is made from Teflon tube.

Installation – Main issues

1. For safety reasons, the SAE Flare seal cap, complete with strap, should not be pressurised.
2. Full instructions are given in the Product Installation Sheet, included with each valve.

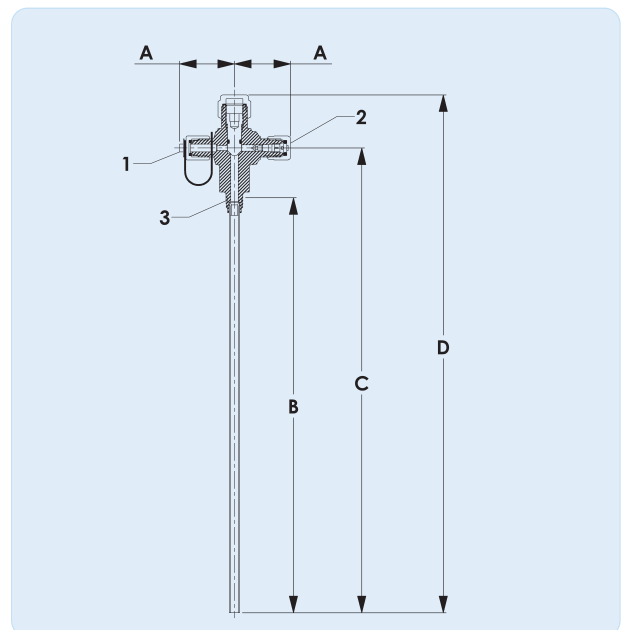

- 1 Side connection - oil outlet
- 2 Side connection - Schrader service port
- 3 Compressor connection

Note: 9297 valve illustrated. 9298 valve has a longer cap as per photograph.

Part No	Conn Size (inch)		Dimensions (mm)				Weight (kg)	CE Cat
	Side	Bottom	A	B	C	D		
9297	1/4 SAE Flare	1/8 MPT	34	254	285	317	1.93	SEP
9298	1/4 SAE Flare	1/4 MPT	34	257	284	350	2.20	SEP

PRESSURE RELIEF VALVES STANDARD RANGE

The function of a Pressure Relief Valve is to protect against over-pressure. For safety reasons, excessive over-pressure in any part of the refrigeration system must be avoided

Applications

A typical application for a Henry Technologies pressure relief valve (PRV) is to protect a liquid receiver from being over-pressurised. In the event of a fire, any liquid refrigerant inside the receiver will evaporate resulting in an increase in pressure. The PRV will safely control this increase in pressure by venting the vapour from the receiver. Another application is to protect equipment from compressor over-pressure.

Henry Technologies pressure relief valves are designed to discharge vapour and should not be used to vent liquid refrigerant. The valves are "back-pressure dependent" and are therefore required to discharge to atmosphere.

The brass and stainless steel series valves are suitable for use with HCFC and HFC refrigerant gases. The stainless steel series valves are also suitable for ammonia.

Once a PRV has discharged, replacement is recommended, as the set pressure can no longer be guaranteed. Refer to Installation Section for further information.

In line with the Institute of Refrigeration Guidelines (UK), Henry Technologies recommend that a PRV should be replaced at least every 5 years. These intervals may have to be reduced if other regulations apply.

It is recommended to have a relief valve pressure setting at least 25% higher than the maximum system operating pressure. The PRV set pressure should not be higher than the design pressure (MWP) of the vessel.

How it works

A conventional PRV is designed to open at a predetermined pressure - the set pressure. A spring exerts a sealing force on a valve seat via a piston seal assembly. At a pressure equal to the set pressure, the piston will start to lift resulting in a small amount of flow through the valve. From this point, the pressure force acting on the piston increases significantly and overcomes the spring force. This imbalance of forces causes the valve to "pop" fully open. By design, the difference in pressure from the valve set point to the fully open condition is no more than 10%. System pressure is controlled/reduced by venting the refrigerant vapour through the valve. The valve then re-closes at a pressure where the spring force overcomes the piston force. Under normal system operating conditions, the pressure at the valve inlet is below the set pressure. Only under abnormal operating conditions should the PRV be open.

Main features

- Proven safe design
- Category IV PED compliant
- Precision machined parts for reliability
- High flow capacity
- Compact
- Non-stick teflon valve seal
- Blow-out proof seal design
- Seal material with high chemical resistance
- Tamper proof
- Test Certificates available on request
- Non-standard pressure settings available on request



Technical Specification

All Henry Technologies standard range PRV's are designed and manufactured to the intent of ASME VIII Division 1.

For 526, 5230 and 5231 series models:-

Set pressure range = 14 to 31 barg
 Allowable operating temperature = -40°C to +107°C

For 5232 and 524 series models:-

Set pressure range = 10.3 to 31 barg
 Allowable operating temperature = -40°C to +107°C

For 53 series models:-

Set pressure range = 10.3 to 31 barg
 Allowable operating temperature = -29°C to +135°C

Materials of Construction

For all 52 series valves, the main body and outlet connection are made from brass. Valve internals such as the piston and adjusting gland are either made from brass, plated steel or stainless steel.

For the 53 series valves, the main body is made from stainless steel. The outlet connection and valve internals are made from either plated steel or stainless steel.

For all valves, the seal is made from premium quality teflon (PTFE). All springs are made from high strength plated alloy steel.

Angle Relief Valve - Brass								
Part No	Conn Size (inch)		Dimensions (mm)		Flow Area (mm ²)	K _{dr}	Weight (kg)	CE Cat
	Inlet	Outlet	A	ØB				
526E-xx.x BAR-CE	3/8 NPTF	3/8 SAE Flare	78	6.35	31.67	0.41	0.26	Cat IV

Straight-through Relief Valves - Brass								
Part No	Conn Size (inch)		Dimensions (mm)		Flow Area (mm ²)	K _{dr}	Weight (kg)	CE Cat
	Inlet	Outlet	A	ØB				
5230A-xx.x BAR-CE	1/4 NPTF	1/2 SAE Flare	85	6.35	31.67	0.68	0.18	Cat IV
5231A-xx.x BAR-CE	3/8 NPTF	1/2 SAE Flare	85	6.35	31.67	0.68	0.19	Cat IV
5231B-xx.x BAR-CE	1/2 NPTF	5/8 SAE Flare	91	6.35	31.67	0.68	0.22	Cat IV
5232A-xx.x BAR-CE	1/2 NPTF	3/4 SAE Flare	109	9.5	71.26	0.67	0.44	Cat IV
5240-xx.x BAR-CE	1/2 NPTF	3/4 NPTF (female)	95	9.5	71.26	0.67	0.41	Cat IV
5242-xx.x BAR-CE	3/4 NPTF	3/4 NPTF (female)	95	9.5	71.26	0.67	0.45	Cat IV
5244-xx.x BAR-CE	1 NPTF	1 NPTF (female)	106	12.7	126.68	0.68	0.66	Cat IV
5246-xx.x BAR-CE	1 1/4 NPTF	1 1/4 NPTF (female)	145	17.9	250.41	0.60	1.48	Cat IV

Straight-through Relief Valves - Stainless Steel								
Part No	Conn Size (inch)		Dimensions (mm)		Flow Area (mm ²)	K _{dr}	Weight (kg)	CE Cat
	Inlet	Outlet	A	ØB				
5340-xx.x BAR-CE	1/2 NPTF	3/4 NPTF (female)	94	9.5	71.26	0.67	0.39	Cat IV
5342-xx.x BAR-CE	3/4 NPTF	3/4 NPTF (female)	94	9.5	71.26	0.67	0.43	Cat IV
5344A-xx.x BAR-CE	3/4 NPTF	1 NPTF (female)	106	12.7	126.68	0.68	0.56	Cat IV
5344-xx.x BAR-CE	1 NPTF	1 NPTF (female)	106	12.7	126.68	0.68	0.62	Cat IV
5345-xx.x BAR-CE	1 NPTF	1 1/4 NPTF (female)	149	17.9	250.41	0.60	1.25	Cat IV
5346-xx.x BAR-CE	1 1/4 NPTF	1 1/4 NPTF (female)	145	17.9	250.41	0.60	1.37	Cat IV

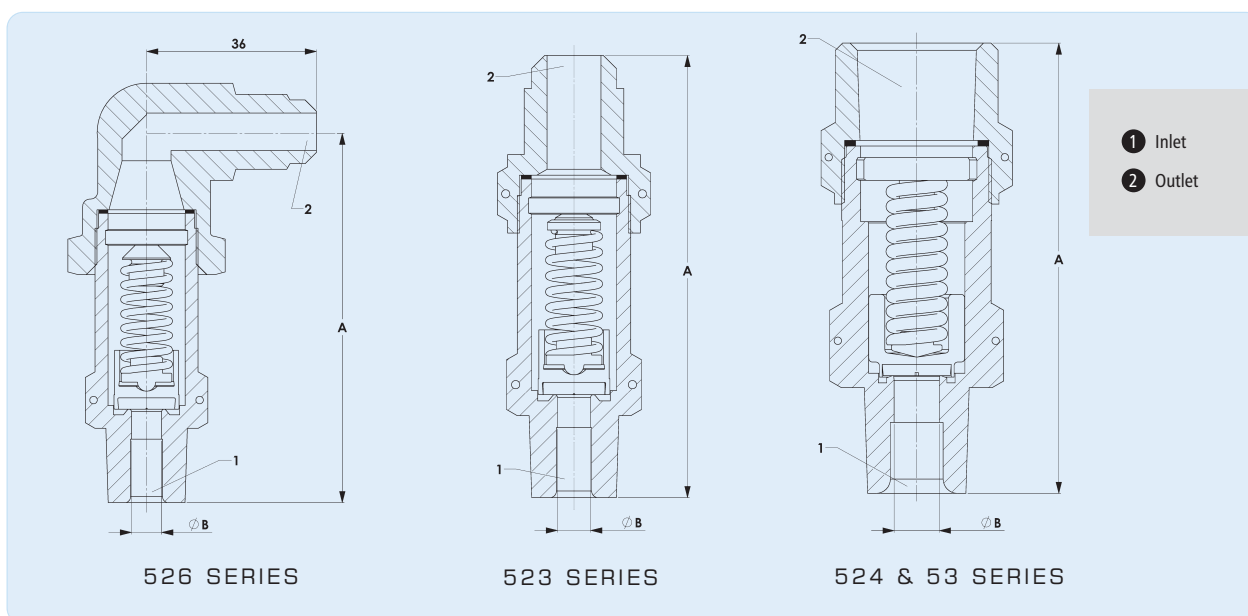

Standard settings are (barg): 10.3, 13.8, 14.0, 16.2, 17.2, 20.7, 24.1, 24.8, 25.0, 25.9, 27.6, 29.3 and 31.0

PRESSURE RELIEF VALVES X SERIES



The 'X' Series of Pressure Relief Valves is based on the proven design of the standard range with some enhanced features. The valves are EN ISO 4126 compliant and will reseal within 15% of set pressure following a discharge. Consequently a minimum amount of refrigerant is lost to the atmosphere. The 523 series can also be used at pressures up to 46 bar.

Main features

- In accordance with EN ISO 4126 the valve reseats within 15% of set pressure following a discharge
- High flow capacity
- Fluoroelastomer soft seat material provides excellent sealing characteristics
- Allowable operating temperature = -40°C to +120°C
- Suitable for HFC, HCFC and CO₂ refrigerant gases
- 53 Series also suitable for R717

Part No	Connection Size (inch)		Dimensions (mm)		Flow Area (mm ²)	K _{dr}	Weight (kg)	CE Cat
	Inlet	Outlet	A	ØB				
	5230AX-xx.x BAR	1/4 NPTF	1/2 SAE Flare	94				
5231AX-xx.x BAR	3/8 NPTF	1/2 SAE Flare	94	7	38.48	0.71	0.39	Cat IV
5231BX-xx.x BAR	1/2 NPTF	5/8 SAE Flare	106	7	38.48	0.71	0.42	Cat IV
5232AX-xx.x BAR	1/2 NPTF	3/4 SAE Flare	119	9	63.62	0.76	0.56	Cat IV
5240X-xx.x BAR	1/2 NPTF	3/4 NPTF (female)	111	9	63.62	0.76	0.55	Cat IV
5242X-xx.x BAR	3/4 NPTF	3/4 NPTF (female)	111	9	63.62	0.76	0.58	Cat IV
5340X-xx.x BAR	1/2 NPTF	3/4 NPTF (female)	111	9	63.62	0.76	0.53	Cat IV
5342X-xx.x BAR	3/4 NPTF	3/4 NPTF (female)	111	9	63.62	0.76	0.57	Cat IV

xx.x = set pressure

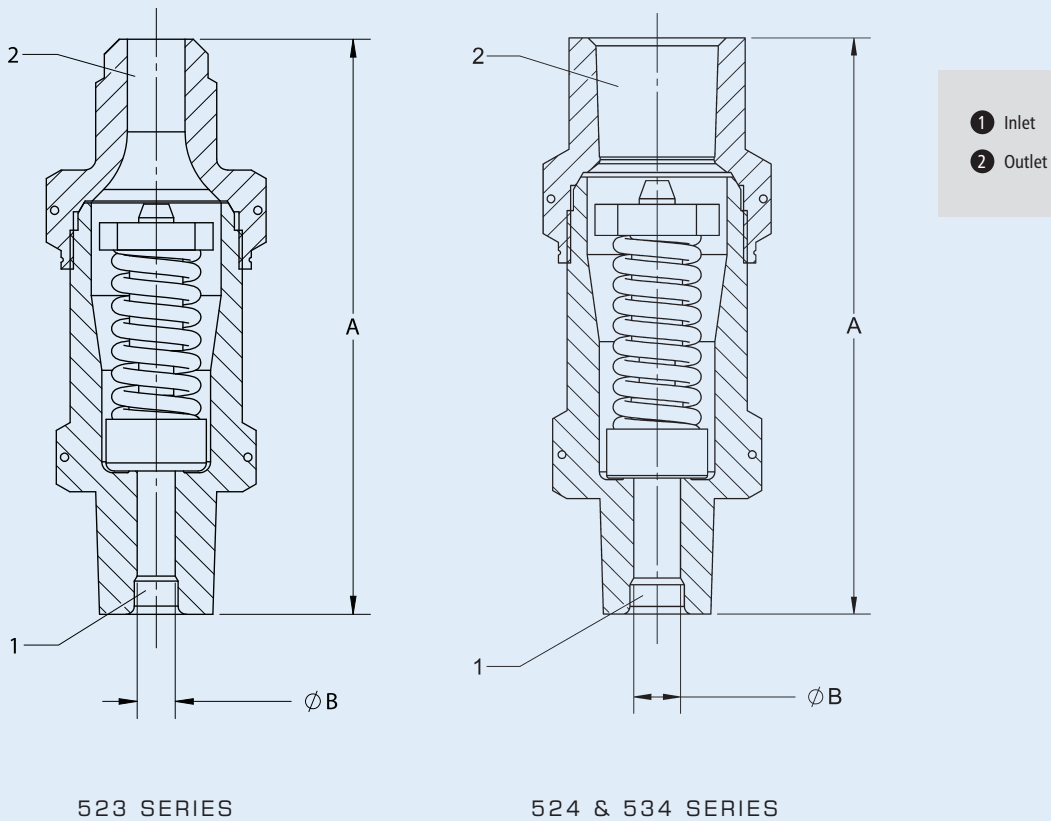

Standard pressure settings (barg): 10.3, 13.8, 14.0, 16.2, 17.2, 20.7, 24.1, 24.8, 25.0, 25.9, 27.6, 29.3, 31.0, 40.0*, 42.0*, 45.0*, 46.0*
*523 series only.

Valve Capacity Ratings (kg Air/min) @ 20°C.										
Part No	Standard Pressure setting (barg)									
	10.3	14.0	16.2	20.7	24.1	24.8	27.6	31.0	40.0	46.0
526E-CE	N/A	2.9	3.3	4.2	4.9	5.1	5.7	6.4	N/A	N/A
5230A-CE	N/A	4.8	5.5	7.0	8.2	8.4	9.4	10.5	N/A	N/A
5231A-CE										
5231B-CE										
5230AX	4.4	6.0	7.0	8.9	10.4	10.7	11.9	13.4	17.2	19.8
5231AX										
5231BX										
5232A-CE	7.8	10.5	12.2	15.6	18.2	18.7	20.8	23.4	N/A	N/A
5240-CE										
5242-CE										
5340-CE										
5342-CE										
5232AX	7.9	10.7	12.4	15.8	18.4	18.9	21.1	23.7	N/A	N/A
5240X										
5242X										
5340X										
5342X										
5244-CE	14.0	19.0	22.0	28.1	32.8	33.7	37.5	42.1	N/A	N/A
5344-CE										
5344A-CE										
5246-CE	24.4	33.2	38.4	49.1	57.1	58.8	65.4	73.5	N/A	N/A
5345-CE										
5346-CE										

N/A denotes a pressure setting unavailable for this model. See product description pages for max and min available settings.

Valve Capacity Table

Discharge capacities for each PRV model are given in the table for a range of standard pressure settings. This table is intended as a reference guide only. Final selection of a relief valve using the method described in EN13136 is recommended.

All capacities shown in the table have been calculated in accordance with the relief valve capacity calculation outlined in EN13136 and using air at 20°C as a reference medium.

If a conversion from air to refrigerant is required, the following formula can be used:

$$W_r = \frac{W_{air}}{\Gamma_w}$$

Where:-

- W_r = Mass flow of refrigerant, kg/min
- W_{air} = Mass flow of air, kg/min
- Γ_w = Conversion factor

Γ_w factors are presented for a number of common refrigerants. These can be used in conjunction with the table to provide an approximation of valve capacity.

Refrigerant	Γ _w
R-11	0.49
R-12	0.51
R-13	0.46
R-22	0.59
R-23	0.52
R-113	0.43
R-114	0.45
R-123	0.47
R-134a	0.56
R-236fa	0.47
R-245fa	0.50
R-290	0.84
R-404A	0.56
R-407C	0.59
R-407F	0.60
R-410A	0.62
R-500	0.56
R-502	0.52
R-507A	0.55
R-600	0.76
R-717	1.28
R-718	1.28
R-744	0.65

ANSI/ASHRAE standard 15-2007

Current European Refrigeration Standards do not use air capacity for valve selection. The information included here is presented for reference purposes and to enable a comparison between valve models to be easily attained.

In line with current European standards, the valve selection procedure outlined in EN13136 is recommended by Henry Technologies. This method uses the valve flow area, A, and de-rated coefficient of discharge, K_{dr}, which are listed in the dimension tables for each valve.

PRESSURE RELIEF VALVES

EN ISO 4126
COMPLIANT

The function of a Pressure Relief Valve is to protect against over-pressure. For safety reasons, excessive over-pressure in any part of a refrigeration system must be avoided.

The 5701AX pressure relief valve is specifically designed for high pressure applications from 46 bar up to 130 bar and in particular, transcritical CO₂ systems. The valves are manufactured from Brass.

Main Features

- Maximum pressure setting of 130 bar
- In accordance with EN ISO 4126, the valve reseats within 15% of set pressure following a discharge
- High flow capacity
- TFM second generation PTFE seal
- Allowable operating temperature = -40°C to +150°C
- Suitable for HFC, HCFC and CO₂ refrigerant gases

Standard pressure settings (barg): 46, 60, 80, 100, 120, 130

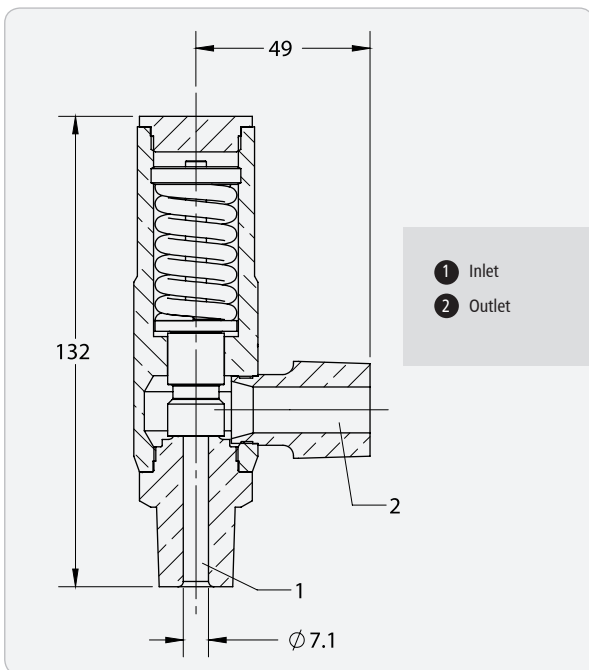
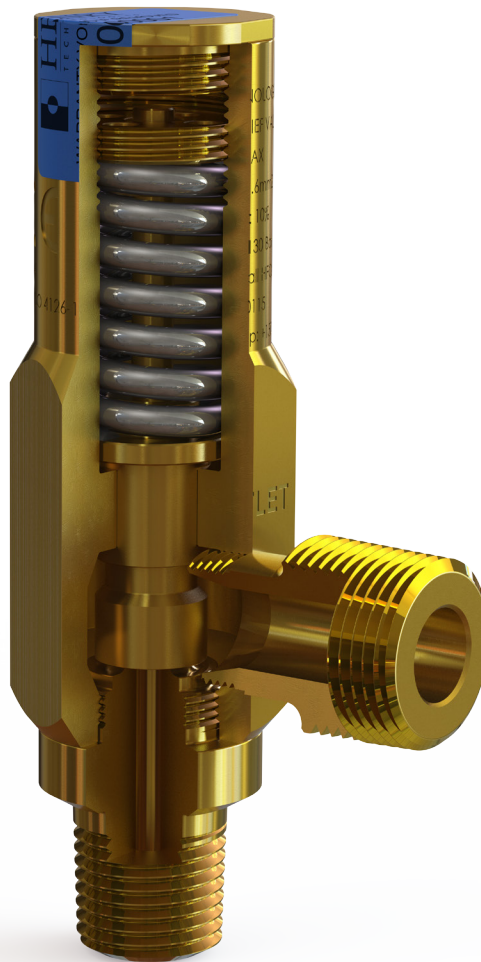

Valve Capacity Ratings (kg Air/min) @ 20°C						
Part No.	Standard Pressure Setting					
	46.0	60.0	80.0	100.0	120.0	130.0
5701AX	20.0	25.9	34.4	42.9	51.4	55.7

High Pressure Angle Relief Valve - Brass						
Part No.	Conn Size (inch)		Flow Area (mm ²)	K _{dr}	Weight (kg)	CE Cat
	Inlet	Outlet				
5701AX	1/2 NPTF	3/4 NPTF	39.59	0.69	0.82	Cat IV

Note: High pressure rupture disc (with pressure settings up to 130 barg) available on request.

Selection Guidelines

For safety reasons, relief valve selection should only be carried out by suitably qualified engineers.

Henry Technologies pressure relief valves are designed to discharge refrigerant vapour and are not recommended for liquid use.

The European Standards EN378 (reference 1) and EN13136 (reference 2) are recommended for PRV selection.

Example

A liquid receiver is to be protected from over-pressure due to fire.

Receiver dimensions = 2.016m long (L) x 0.841m outside diameter (D)
 Refrigerant = R744 (CO₂)
 Pressure Setting = 50.0 barg

$$Q_{md} = \frac{3600 \times \phi \times A_{surf}}{h_{vap}}$$

Q_{md} = Minimum required discharge capacity, of refrigerant, of the pressure relief valve (kg/hour)

ϕ = Density of heat flow rate (kW/m²). The standards assume a value to 10 kW/m² but state that a higher value can be used if necessary. This figure relates to an un-lagged vessel.

A_{surf} = External surface area of the vessel (m²)

h_{vap} = Heat of vaporisation calculated at 1.1 times the set pressure, in bar a, of the pressure relief valve (kJ/kg)

Note:

When the relief valve setting is close to the critical pressure of the refrigerant, this sizing method may not be applicable.

$$A_{surf} = (\pi \times D \times L) + 2 \left(D^2 \times \frac{\pi}{4} \right)$$

$$A_{surf} = (\pi \times 0.841 \times 2.016) + 2 \left(0.841^2 \times \frac{\pi}{4} \right) = 6.44 \text{ m}^2$$

Calculate the heat of vaporisation, h_{vap} , taken at 1.1 times set pressure:

$$P_D = (P_{set} \times 1.1) + P_{atmos} = (50.0 \times 1.1) + 1.013 = 56.01 \text{ bar a}$$

From refrigerant property tables, use saturated vapour and liquid enthalpies at P_D .

Vapour = 410.59 kJ/kg

Liquid = 252.44 kJ/kg

$$h_{vap} = 410.59 - 252.44 = 158.15 \text{ kJ/kg}$$

The minimum required discharge rate of R744 can now be calculated for this vessel and set pressure:

$$Q_{md} = \frac{3600 \times \phi \times A_{surf}}{h_{vap}} = \frac{3600 \times 10 \times 6.44}{158.15} = 1465.95 \text{ kg/hr, R744}$$

For relief valve discharge capacity, Q_m :

$$Q_m = 0.2883 \times C \times A \times K_{dr} \times K_b \times \sqrt{\frac{P_D}{V_D}}$$

Q_m = Discharge capacity, of refrigerant, of the pressure relief valve (kg/hr)

C = Function of the isentropic exponent

A = Flow area of PRV (mm²)

K_{dr} = De-rated coefficient of discharge of PRV

K_b = Theoretical capacity correction factor for sub-critical flow.
 A value of 1 is used for critical flow.

P_D = Actual relieving pressure of PRV (bar a)

V_D = Specific volume of saturated vapour at P_D (m³/kg)

Refrigerant data should be referenced for values of C and V_D .

The objective is to select a PRV which results in $Q_m > Q_{md}$. In this way, the relieving capacity of the PRV is greater than required thus avoiding excessive vessel pressure.

For this example, a 5701AX has been selected:

$$A = 39.59 \text{ mm}^2$$

$$K_{dr} = 0.69$$

$$Q_m = 0.2883 \times 2.63 \times 39.59 \times 0.69 \times 1 \times \sqrt{\frac{56.01}{0.0054}} = 2,109.5 \text{ kg/hr, R744}$$

$Q_m > Q_{md}$, therefore the 5701AX would be suitable for this system.

Important selection notes:

1. It is important not to grossly over-size a PRV so that Q_m is many times greater than Q_{md} as the performance of the PRV can be affected. Contact Henry Technologies for further guidance.
2. Henry Technologies recommends inlet and outlet piping for all PRVs are sized in accordance with EN13136 (reference 2) to avoid excessive pressure losses which can affect valve performance.
3. If a Henry Technologies rupture disc is used in conjunction with a Henry Technologies PRV, the PRV capacity should be de-rated by 10%. In the above example, the PRV capacity would be de-rated to 1,898.5 kg/hr (2,109.5 x 0.9).

References:

1. BS EN 378-2:2008+A2:2012*
2. BS EN 13136:2013*

*Latest revisions at the time of publication. The user should ensure the latest revisions are referenced.

Installation – Main issues

1. Connect the relief valve at a location above the liquid refrigerant level, in the vapour space. Stop valves should not be located between the vessel and the relief valve except the three-way type.
2. Do not discharge the relief valve prior to installation or when pressure testing the system.
3. Pressure relief valves should be mounted vertically.
4. Relief valves should be changed out after discharge. Most systems are subject to accumulations of debris and particles of metal and dirt are generally blown onto relief valve seats during discharge. This can inhibit the relief valve from re-sealing at the original set pressure. A valve can also relieve at a lower pressure than the stamped setting due to the force of the re-closing action.
5. The pipe-work must not impose loads on the relief valve. Loads can occur due to misalignment, thermal expansion, discharge gas thrust, etc.
6. Transcritical CO₂ systems should generally be sized with the shortest length and largest bore outlet pipe work practical to avoid solids forming downstream of the PRV during a discharge.

RUPTURE DISCS

The function of a Rupture Disc is to protect against over-pressure. For safety reasons, excessive over-pressure in any part of the refrigeration system must be avoided. A rupture disc is generally used in combination with a Henry Technologies pressure relief valve.

Applications

A rupture disc protects against any leakage or weeping of refrigerant through a relief valve. A rupture disc can also be used in combination with a pressure gauge and/or pressure switch to detect if a relief valve has discharged.

Henry Technologies rupture discs are designed to operate with gases and should not be used to prevent liquid over-pressure.

The brass 55 series models are suitable for use with HCFC, HFC and CO₂ refrigerant gases. The stainless steel 56 series models are also suitable for ammonia.

In line with the Institute of Refrigeration Guidelines (UK), it is recommended that at least every 2 years all high side bursting discs should be replaced. At least every 5 years all low side bursting discs should be replaced. These intervals may have to be reduced if other regulations apply.

How it works

A foil disc is clamped in a holder. The disc is designed to burst at a pre-determined pressure - the set pressure. A reverse acting disc is used. This means that the disc is domed against the direction of the fluid pressure and designed to buckle due to compression forces, prior to bursting. Advantages of a reverse acting disc include being less sensitive to temperature, high operating pressures and improved fatigue life. Each disc is manufactured with a precision score mark. This score mark in combination with the buckling action causes the disc to burst. At burst, the disc is designed to hinge resulting in a large available flow area. The disc is designed to be non-fragmenting after rupturing.

Main features

- Proven safe design
- CE marked
- High flow capacity
- Compact
- Reverse acting, non-fragmenting disc
- 2 x 1/8 NPT pressure ports
- Helium leak tested
- Pressure settings up to 130 barg available on request
- EN ISO 4126-2 Compliant

Technical Specification

Set pressure range = 10.3 to 31 barg

Set pressure range = 10.3 to 130 barg (5526 series)

Allowable operating temperature = -40°C to +107°C

Materials of Construction

For 55 and 56 series, the main bodies are made from brass and stainless steel respectively.

The foil disc is made from Nickel alloy.



Tolerance Guidelines

As per industry standards, rupture disc rated burst pressures are subject to a performance tolerance.

When specifying a disc, the nominal pressure setting should be quoted as part of the part number (see table below). The rupture disc will be provided with a rated burst pressure stamped on the body, which is the average of all burst tests carried out on the batch of discs. As a result, the rated burst pressure may differ slightly from the nominal setting depending on the manufacturing tolerance for the specific batch of discs. This manufacturing tolerance will never be greater than +/-5% and in the majority of cases is significantly less.

The rated burst pressure is subject to a performance tolerance of +/-5%. Examples of actual burst pressure ranges are shown in the table below for a selection of typical rated pressure settings.

Performance Tolerance Examples	
Rated Burst Pressure (barg)	Burst Pressure Range (barg)
10.3	9.8 - 10.8
14	13.3 - 14.7
16.2	15.4 - 17.0
17.2	16.3 - 18.0
20.7	19.7 - 21.7
24.1	22.9 - 25.3
24.8	23.6 - 26.0
25.9	24.6 - 27.2
27.6	26.2 - 29.0
31	29.5 - 32.6
40	38 - 42

Part No	Conn Size (inch)		Dimensions (mm)					Nominal rupture disc setting at 22°C (barg)	Weight (kg)	CE Cat
	Inlet	Outlet	A	B	ØC	D	MNFA, mm² (note 1)			
5525-16.2 Bar-CE	3/8 MPT	3/8 FPT	65	31.8 A/F	9.7	20	64.5	16.2	0.28	Cat IV
5525-20.7 Bar-CE								20.7		
5525-24.1 Bar-CE								24.1		
5525-25.9 Bar-CE								25.9		
5525-27.6 Bar-CE								27.6		
5525-31.0 Bar-CE								31.0		
5525-40.0 Bar-CE	1/2 MPT	1/2 FPT	73	31.8 A/F	12.7	23	109.7	40.0	0.30	Cat IV
5526-14.0 Bar-CE								14.0		
5526-16.2 Bar-CE								16.2		
5526-20.7 Bar-CE								20.7		
5526-24.1 Bar-CE								24.1		
5526-24.8 Bar-CE								24.8		
5526-25.9 Bar-CE								25.9		
5526-27.6 Bar-CE								27.6		
5526-31.0 Bar-CE								31.0		
5526-40.0 Bar-CE								40.0		
5626-10.3 Bar-CE	1/2 MPT	1/2 FPT	73	Ø28.6	12.7	23	109.7	10.3	0.20	Cat IV
5626-17.2 Bar-CE								17.2		
5626-20.7 Bar-CE								20.7		
5627-10.3 Bar-CE	3/4 MPT	3/4 FPT	81	Ø38.1	19	29	187.1	10.3	0.34	Cat IV
5627-17.2 Bar-CE								17.2		
5627-20.7 Bar-CE								20.7		
5628-10.3 Bar-CE	1MPT	1FPT	93	Ø44.5	25.5	32	335.5	10.3	0.56	Cat IV
5628-17.2 Bar-CE								17.2		
5628-20.7 Bar-CE								20.7		
5629-10.3 Bar-CE	1 1/4 MPT	1 1/4 FPT	95	50.8 A/F	33.3	33	683.9	10.3	0.76	Cat IV
5629-17.2 Bar-CE								17.2		
5629-20.7 Bar-CE								20.7		

Note 1: MNFA = Minimum net flow area. The MNFA is the net area after a complete disc burst, taking into account any structural members which reduce the nominal flow area. MNFA should be used as the flow area, A, in flow capacity calculations

Selection Guidelines

1. The rupture disc pressure setting should be the same as the Henry Technologies pressure relief valve setting.
2. The rated burst pressure is subject to a performance tolerance of +/- 5 %. This tolerance should be taken into account when specifying a rupture disc setting (refer to table).
3. The burst pressure is affected by operating fluid temperature. Refer to table for temperature adjustment factors. At higher operating temperatures the disc burst pressure is reduced while at sub-zero temperatures it is increased. This factor should be taken into account when specifying a rupture disc setting.

Temperature range, °C	Temperature adjustment factor
-40 to -18	1.05
-17 to -1	1.04
0 to +45	1
+46 to +80	0.98
+81 to +107	0.97

4. It is recommended that the maximum operating pressure of the system is no more than 80% of the rated burst pressure, in order to minimise the risk of premature fatigue failure of the disc. If operating pressures exceed 90% of the rated burst pressure, the disc should be replaced immediately.
5. The design fatigue strength of each disc is 100,000 pressure cycles. Fatigue life will be reduced by excessive pressures or temperatures, corrosion, damage, etc.

Example

Rupture disc rated burst pressure = 31 barg @ 22°C
 Minimum actual burst pressure, using performance tolerance = 0.95 x 31 = 29.45 barg
 Maximum actual burst pressure, using performance tolerance = 1.05 x 31 = 32.55 barg
 Maximum operating fluid temperature = 40°C

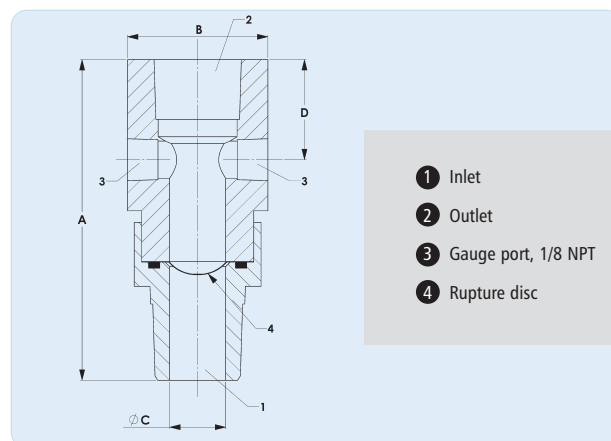

To determine the recommended maximum operating pressure, the user should consider the -5% performance tolerance and the de-rate factors for both temperature and fatigue life.

Therefore:-

Minimum actual burst pressure = 29.45 barg
 Temperature de-rate factor = 1.0
 Fatigue life de-rate factor = 0.8

Recommended maximum operating pressure for rupture disc = 29.45 x 1.0 x 0.8 = 23.6 barg.

Installation – Main Issues

1. Connect the rupture disc either directly to the pressure vessel or to a three-way valve above the liquid refrigerant level in the vapor space.
2. The rupture disc comprises of a two-piece body design. To avoid damage during assembly or removal, the product Installation Instructions must be followed.
3. The pipework must not impose loads on the rupture disc. Loads can occur due to misalignment, thermal expansion, discharge gas thrust, etc.

THREE-WAY DUAL SHUT-OFF VALVES

The function of a three-way valve is to permit replacement of one of the pressure relief devices, while the other is protecting the pressure vessel. In this way, a vessel is protected from over-pressure during servicing. It also allows a pressure relief device to be replaced in-situ, without removing the system refrigerant charge.

Applications

All three-way valves are suitable for HCFC and HFC refrigerants along with their associated oils. The 802 series is also suitable for ammonia.

Refrigeration standard, EN378, specifies that a three-way valve is required on vessels of a certain size. EN378, or an equivalent National Standard, should be consulted for further guidance. It should be recognised however that a three-way valve can be fitted to a vessel of any size, to enable safe, easy and economical replacement of pressure relief devices.

Main features

- Proven robust design
- Compact

Technical Specification

Allowable operating pressure = 0 to 31 barg (802 series)
 Allowable operating pressure = 0 to 46 barg (92 series)
 Allowable operating temperature = -29°C to +149°C

Materials of Construction

The 92 and 802 series valve bodies are made from brass and carbon steel respectively. The stem is made from plated steel. The stem seal packing is made from either PTFE or graphite based material. The seal cap is made from moulded plastic.

Installation – Main issues

1. Assemble the three-way valve to a vessel using a high strength pipe nipple.
2. The pipework must not impose loads on the valve. Loads can occur due to misalignment, thermal expansion, discharge gas thrust, etc

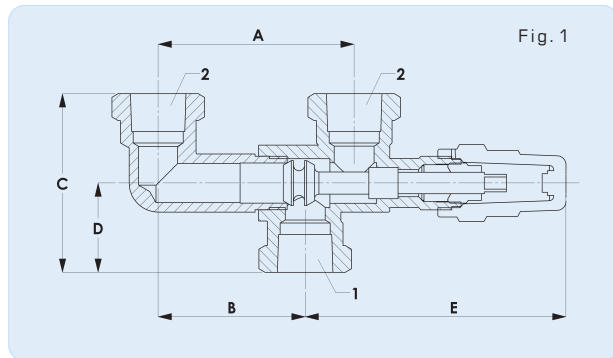

- ① Inlet
- ② Outlet

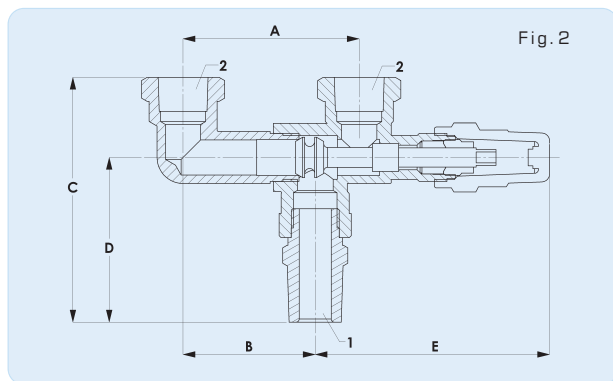

Type	Part No	Inlet Conn Size (inch)	Outlet Conn Size (inch)	Dimensions (mm)					Drawing reference	Weight (kg)	Kv (m³/hr)	CE Cat
				A	B	C	D	E				
92	923	3/8 FPT	3/8 FPT	70	52	64	32	93	fig.1	0.51	2.80	SEP
92	923M	3/8 MPT	3/8 FPT	70	52	90	57	93	fig.2	0.57	2.80	SEP
92	925	1/2 FPT	1/2 FPT	70	52	64	32	93	fig.1	0.47	2.83	SEP
92	925M	1/2 MPT	1/2 FPT	70	52	97	65	93	fig.2	0.57	2.83	SEP
92	927	3/4 FPT	3/4 FPT	70	52	70	35	100	fig.1	0.70	3.48	SEP
802*	8021A	1/2 FPT	1/2 FPT	92	59	86	44	146	fig.1	1.47	4.78	SEP
802*	8022A	3/4 FPT	3/4 FPT	92	59	86	44	146	fig.1	1.33	7.60	SEP
802*	8024-CE	1 FPT	1 FPT	148	94	99	51	191	fig.1	3.70	10.07	SEP (Cat I)
802*	8025-CE	1 1/4 FPT	1 1/4 FPT	148	94	99	51	191	fig.1	3.25	14.36	Cat I (Cat II)

*Suitable for Ammonia. Brackets indicate CE category for Ammonia use.

PRESSURE INDICATOR

The function of the Pressure Indicator is to provide visual indication in the event of a rupture disc burst. If the disc has ruptured, the pressure relief valve will have discharged and must be replaced. (refer to Sentry safety device information).

Applications

The G16 Pressure Indicator is intended to be used as part of the Henry Sentry safety device assembly.

The unit is suitable for use with HCFC, HFC and ammonia refrigerants, along with their associated oils.

Main features

- Easy to read large indicator dial
- Stainless steel movement

Technical Specification

Allowable operating pressure = 0 to 55 barg

Allowable operating temperature = -40°C to + 65°C

Materials of Construction

Stainless steel case and movement.

Plexiglas dial window.



Part No	Weight (g)	CE Cat
G16	27	SEP

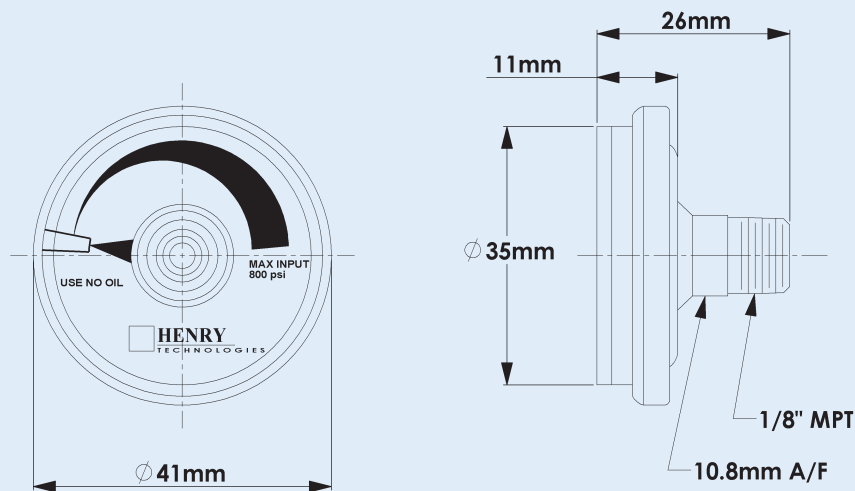

SENTRY SAFETY DEVICE ASSEMBLIES

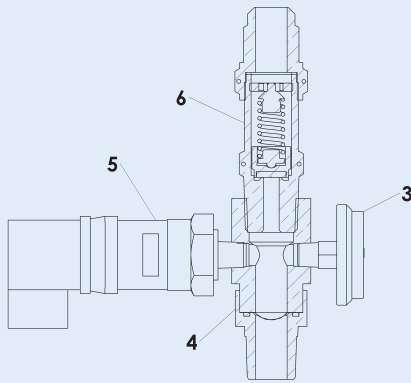

SENTRY SINGLE SAFETY
DEVICE ASSEMBLY

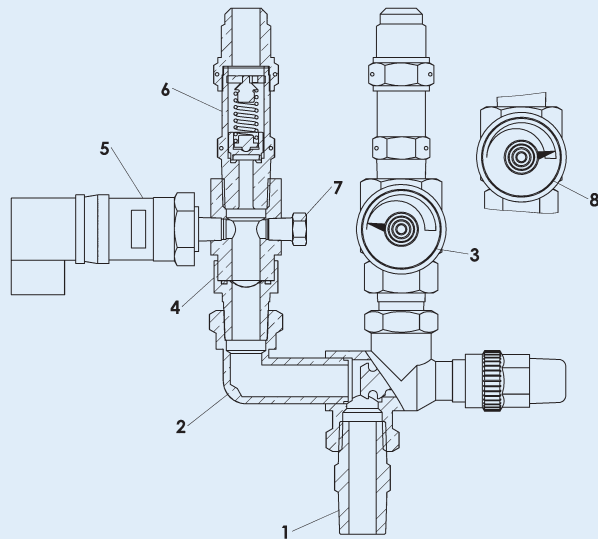

SENTRY DUAL SAFETY
DEVICE ASSEMBLY

- | | | | |
|-------------------|-----------------------------------|------------------------------|--------------------------------|
| 1 Pipe nipple | 3 G16 gauge (no pressure applied) | 5 Pressure switch (optional) | 7 Plug, 1/8 NPT |
| 2 Three-way valve | 4 Rupture disc | 6 Relief valve | 8 G16 gauge (pressure applied) |

Refer to relevant catalogue pages for information on each component.

The primary purpose of a Sentry safety device assembly is to provide a positive seal between the system and atmosphere and facilitate an indicating device to be fitted. The indicating device notifies the user if the pressure relief valve has discharged. This is a requirement of Refrigeration Standard EN378.

A dual Sentry safety device assembly also provides a safe and economical method for replacing safety devices on a pressure vessel. Typically, this vessel will be a refrigerant liquid receiver. The Sentry assembly protects the receiver from over-pressure.

The Sentry safety device assemblies comprise a number of items from the Henry Technologies product range. There are two versions; a single safety device assembly and a dual safety device assembly.

The single safety device assembly comprises of a pressure relief valve, rupture disc, pressure indicator gauge and an optional pressure switch.

The dual safety device assembly comprises two pressure relief valves, two rupture discs, two pressure indicator gauges, two optional pressure switches and a three way valve.

Note: Each pressure relief device must have the required capacity to protect the vessel from over-pressure.

For both assemblies, a 1/8" NPT rupture disc blanking plug is required if the user does not fit both the pressure gauge and pressure switch. For the dual assembly, a pipe nipple is normally required to assemble the three-way valve to the pressure vessel.

In general, the user needs to order the individual items in each assembly. For popular combinations, SDK safety device kits are available.

Applications and Features

In line with the Institute of Refrigeration Guidelines (UK), Henry Technologies recommend that pressure relief valves and low side rupture discs be replaced at least every 5 years. All high side rupture discs should be replaced every 2 years. These intervals may have to be reduced if other regulations apply. The dual Sentry assembly provides a convenient solution for the replacement of safety devices along with other user benefits.

The features of a dual Sentry Assembly are:-

- Safe, easy and economical maintenance:** The three-way valve permits replacement of one of the relief devices, while the other is protecting the pressure vessel. In this way, a vessel is protected from over-pressure during servicing. It also allows a pressure relief device to be replaced in-situ, without removing the system refrigerant charge.
- Protection against over-pressure:** the rupture disc and relief valve will open at a pre-determined value to prevent excessive pressure.
- Code Compliance:** Refrigeration Codes specify that a three-way valve is required on vessels of a certain size.
- Hermetic sealing:** During normal operation, the rupture disc prevents any leakage or weeping of refrigerant through the relief valve.
- Warning of safety device discharge:** Both the pressure gauge and pressure switch indicate if the relief valve has discharged. The pressure gauge provides a visual indication. The pressure switch provides an electrical signal which can be used as an alarm.
- Inter-space monitoring:** The pressure gauge and pressure indicator can be used to check that the bursting disc is intact. This provides a warning in case there is a build up of pressure behind the disc, as a result of damage. Any back pressure will increase the design relief pressure of the rupture disc.

In comparison, the features of a single Sentry assembly are; protection against over-pressure, hermetic sealing, warning of safety device discharge and inter-space monitoring.

Sentry Assembly Combinations

The table shows the recommended relief valve, rupture disc and three-way valve combinations. Please refer to the relief valve catalogue pages for outlet connection sizes.

Relief Valve	Rupture Disc	Three-Way Valve	Conn Size, inch (NPT)
Part No	Part No	Part No	
526E	5525	923	3/8
5231A	5525	923	3/8
5231AX	5525	923	3/8
5231B	5526	925	1/2
5231BX	5526	925	1/2
5232A, 5240, 5232AX, 5240X	5526	8021A or 925 (see note)	1/2
5340, 5340X	5626	8021A	1/2
5242, 5242X	5627	8022A or 927 (see note)	3/4
5342, 5342X, 5344A	5627	8022A	3/4
5244, 5344, 5345	5628	8024-CE	1
5246, 5346	5629	8025-CE	1 1/4

Note: Where possible, it is best to select the three way valve model with the larger Kv value.

How it works

The diagram (below) shows the rupture disc intact. Normal system pressure acts on the rupture disc. There is no pressure in the chamber between the rupture disc and relief valve. Note that the pressure is diverted to one side of the three-way valve only, allowing the valve on the other side to be safely removed, if required.

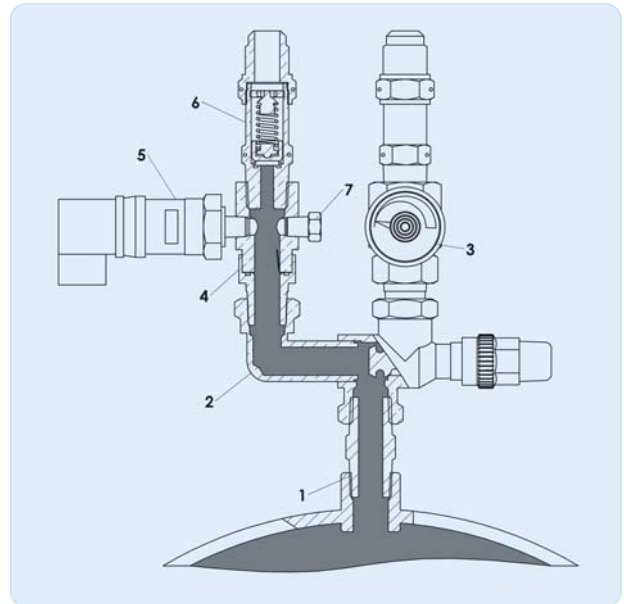
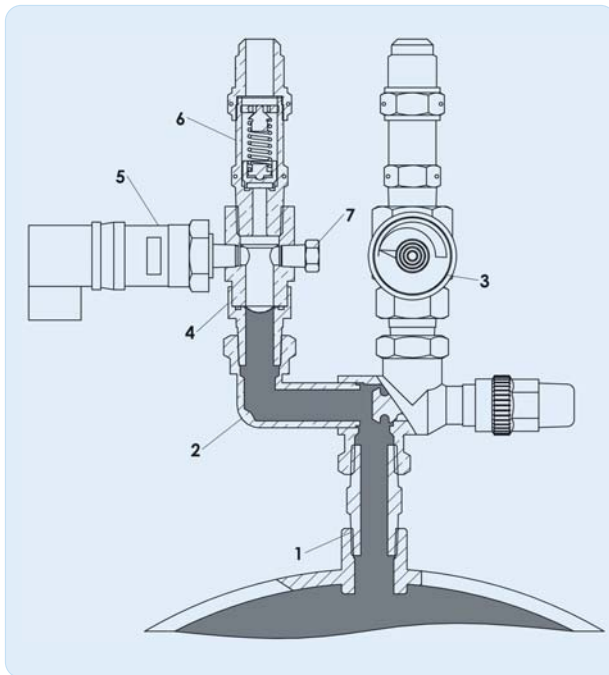

The diagram (above) shows the rupture disc burst. The pressure is now contained by the relief valve only. The pressure switch would now detect the pressure in the chamber between the rupture disc and relief valve. The gauge, if fitted, would indicate that pressure is acting in this chamber. In this condition, the relief valve will have discharged due to system over-pressure. Both the relief valve and rupture disc now need to be replaced.

SAFETY DEVICE KITS

The function of a Safety Device Kit is to protect against over-pressure. For safety reasons, excessive over-pressure in any part of the refrigeration system must be avoided. The 'X' denotes that the kit includes an 'X' series PRV.

Four kits are available, SDK1, SDK2, SDK1X and SDK2X.

The SDK1/X kit is a single safety device assembly. It comprises of a pressure relief valve, rupture disc, pressure indicator gauge and a 1/8" NPT rupture disc blanking plug.

The SDK2/X kit is a dual safety device assembly. It comprises of two pressure relief valves, two rupture discs, two pressure indicator gauges, two blanking plugs, a three-way valve and a 1/2" NPT pipe nipple.

Applications

A typical application for a Henry Technologies Safety Device Kit is to protect a liquid receiver from being over-pressurised. Refer to the catalogue pages for a description on the function of each individual component. The kits are designed for use with HCFC and HFC refrigerants, along with their associated oils

Main features

- Combines Henry Technologies relief devices in one easy-to-order kit
- Components packed into compact display carton
- Easy to store

Technical Specification

Refer to the catalogue pages for the maximum operating pressures and temperatures for each item.

Materials of Construction

The main components for the SDK kits are made from brass and steel. Refer to individual catalogue pages for details on each component.

Selection Data

Selection of relief devices should be as outlined in respective catalogue pages. Ensure that relief valve selection guidance is followed prior to ordering of kits.



Part No	Relief Valve		Rupture Disc		Indicator Gauge	
	Part No	Qty	Part No	Qty	Part No	Qty
SDK1-14.0BAR-CE	5231B-14.0BAR-CE	1	5526-14.0BAR-CE	1	G16	1
SDK1-16.2BAR-CE	5231B-16.2BAR-CE	1	5526-16.2BAR-CE	1	G16	1
SDK1-17.2BAR-CE	5231B-17.2BAR-CE	1	5526-17.2BAR-CE	1	G16	1
SDK1-20.7BAR-CE	5231B-20.7BAR-CE	1	5526-20.7BAR-CE	1	G16	1
SDK1-24.1BAR-CE	5231B-24.1BAR-CE	1	5526-24.1BAR-CE	1	G16	1
SDK1-24.8BAR-CE	5231B-24.8BAR-CE	1	5526-24.8BAR-CE	1	G16	1
SDK1-25.9BAR-CE	5231B-25.9BAR-CE	1	5526-25.9BAR-CE	1	G16	1
SDK1-27.6BAR-CE	5231B-27.6BAR-CE	1	5526-27.6BAR-CE	1	G16	1
SDK1-31.0BAR-CE	5231B-31.0BAR-CE	1	5526-31.0BAR-CE	1	G16	1
*SDK1X-40.0BAR-CE	5231BX-40.0BAR-CE	1	5526-40.0BAR-CE	1	G16	1

SDK1X versions also available. *SDK1X only at this pressure.

Part No	Relief Valve		Rupture Disc		Indicator Gauge		Three-way Valve	
	Part No	Qty	Part No	Qty	Part No	Qty	Part No	Qty
SDK2-14.0BAR-CE	5231B-14.0BAR-CE	2	5526-14.0BAR-CE	2	G16	2	925	1
SDK2-16.2BAR-CE	5231B-16.2BAR-CE	2	5526-16.2BAR-CE	2	G16	2	925	1
SDK2-17.2BAR-CE	5231B-17.2BAR-CE	2	5526-17.2BAR-CE	2	G16	2	925	1
SDK2-20.7BAR-CE	5231B-20.7BAR-CE	2	5526-20.7BAR-CE	2	G16	2	925	1
SDK2-24.1BAR-CE	5231B-24.1BAR-CE	2	5526-24.1BAR-CE	2	G16	2	925	1
SDK2-24.8BAR-CE	5231B-24.8BAR-CE	2	5526-24.8BAR-CE	2	G16	2	925	1
SDK2-25.9BAR-CE	5231B-25.9BAR-CE	2	5526-25.9BAR-CE	2	G16	2	925	1
SDK2-27.6BAR-CE	5231B-27.6BAR-CE	2	5526-27.6BAR-CE	2	G16	2	925	1
SDK2-31.0BAR-CE	5231B-31.0BAR-CE	2	5526-31.0BAR-CE	2	G16	2	925	1
*SDK2X-40.0BAR-CE	5231BX-40.0BAR-CE	2	5526-40.0BAR-CE	2	G16	2	925	1

SDK2X versions also available. *SDK2X only at this pressure.

Y STRAINER

The function of a Y strainer is to remove system debris from refrigerant and oil.

Applications

The Y Strainer can be fitted anywhere in a refrigeration or air – conditioning system where equipment needs to be protected from debris.

The unit is suitable for HCFC and HFC refrigerants, along with their associated oils.

Main features

- Large screen area for low pressure drop and long life
- Removable screen for cleaning
- Solder connection and NPT thread options

Technical Specification

Allowable operating pressure = 0 to 34.5 barg

Allowable operating temperature = -29°C to +93°C

Materials of Construction

The strainer assembly is made from brass with a stainless steel mesh screen.

The O-ring is made from neoprene.

Installation – Main issues

1. Install strainer in the correct orientation. It is recommended to install valves on either side of the unit to ease replacement, in the event that the mesh screen becomes blocked.

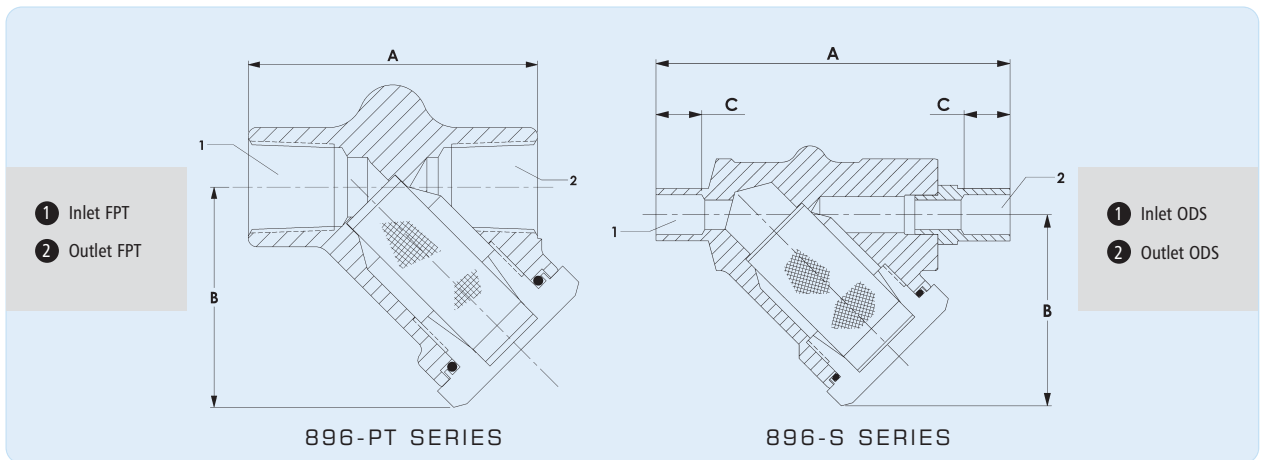

Part No	Conn Size (inch)	Dimensions (mm)			Screen data		Weight (kg)	CE Cat
		A	B	C	Area (mm ²)	Mesh		
896-1/4PT	1/4 FPT	54	41	-	1290	100	0.25	SEP
896-3/8PT	3/8 FPT	54	41	-	1290	100	0.22	SEP
896A-3/8S	3/8 ODS	86	46	11	2030	100	0.38	SEP
896A-1/2S	1/2 ODS	87	46	13	2030	100	0.38	SEP
896A-5/8S	5/8 ODS	90	46	16	2030	100	0.36	SEP
896B-5/8S	5/8 ODS	114	65	16	4520	100	1.14	SEP

MOISTURE INDICATORS

The primary function of a Moisture Indicator is to provide a visual indication of system moisture levels. However, the unit can also be used as a liquid refrigerant or oil return indicator.

Applications

"Dri-Vue" Henry Technologies moisture indicators are approved for use with specific HCFC and HFC refrigerants, along with their associated oils.

Main features

- Patented Henry Technologies Design #
- Large sight glass – easy view
- Positive colour contrast indicator paper
- Replaceable indicator seal cap
- In-built filter screen protects indicator paper
- Plastic protection cap supplied as standard
- SAE Flare or solder connections

US patent 5852937

Technical Specification

Allowable operating pressure = 0 to 34.5 barg
 Allowable operating temperature = -10°C to +93°C

Materials of Construction

The main body is made from brass. The seal cap comprises a fused sight glass in a plated carbon steel housing. The seal cap is screwed to the main body and sealed with a PTFE gasket.

Performance Data

The indicator colour versus moisture content, PPM, is presented in the table for different refrigerants. The moisture content level varies with operating fluid temperature.

The colour is an indicator of the dryness of the refrigerant:-

Colour indicators: Dry = Green, Caution = Chartreuse, Wet = Yellow.

Installation – Main Issues

1. For solder connection moisture indicators, the seal cap assembly should be removed prior to brazing.
2. If the indicator paper becomes discoloured or damaged, the seal cap should be replaced. Replacement seal cap part number is MI-3.

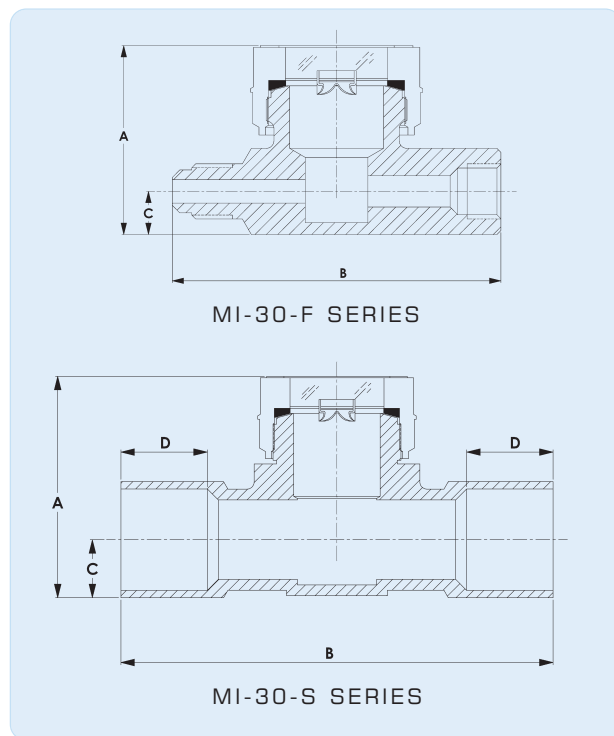

Type	Part No	Conn Size (inch)	Dimensions (mm)				Weight (kg)	CE Cat
			A	B	C	D		
MI-30-F	MI-30-1/4F	1/4 SAE Flare male x female	38	67	9	N/A	0.20	SEP
	MI-30-3/8F	3/8 SAE Flare male x female	43	71	12	N/A	0.26	SEP
	MI-30-1/2F	1/2 SAE Flare male x female	42	80	10	N/A	0.27	SEP
MI-30-S	MI-30-1/4S	1/4 ODS	38	67	9	8	0.20	SEP
	MI-30-3/8S	3/8 ODS	38	67	9	8	0.19	SEP
	MI-30-1/2S	1/2 ODS	38	67	9	10	0.18	SEP
	MI-30-5/8S	5/8 ODS	43	75	12	13	0.22	SEP
	MI-30-7/8S	7/8 ODS	49	95	13	19	0.33	SEP
	MI-30-1 1/8S	1 1/8 ODS	54	84	16	23	0.29	SEP

'DRI-VUE' MOISTURE - COLOUR TABLE

Refrigerant type	Moisture content (parts per million)			
	Temp (°C)	Indicator colour		
		Green	Chartreuse	Yellow
R404A	24	below 15	15-90	Above 90
	38	below 25	25-115	Above 115
	52	below 30	30-140	Above 140
R22	24	below 30	30-120	Above 120
	38	below 45	45-180	Above 180
	52	below 60	60-240	Above 240

REPLACEMENT COMPONENTS

CHECK VALVES

Replacement parts kits for NRV series Check valves

Kit includes brass cap, O-ring, plunger assembly, spring, plastic cap and instruction sheet.

Part No	Suitable for Check valves
NRV 14/18-S1	NRV14 and NRV18
NRV 22/26-S1	NRV22 and NRV26

GLOBE VALVES

Replacement parts kits for RLV series Globe valves

Gasket spares kit comprising: 3-off O-rings and Teflon cap gasket.
Main spares kit comprising: bonnet, spindle, spindle sleeve, brass back seat, nylon seat ring, retaining nut and washer, gland nut, 4-off O-rings, Teflon cap gasket and instruction sheet.

Part No	Description
RLV 14/18 S1	Gasket spares for RLV14/18 valves
RLV 14/18 S2	Main spares for RLV14/18 valves
RLV 22/26 S1	Gasket spares for RLV22/26 valves
RLV 22/26 S2	Main spares for RLV22/26 valves

Replaceable Cartridges for discontinued Filter Driers

Replaceable DRI-COR® cartridges for discontinued brass shell series suction line filters.

Part No.	Drier Dia (Inches)	Cartridge Type	Volume (cm ³)	A.R.I. Cap Ratings Drops of water		Cartridge	
				R22 (60ppm)		Length (mm)	Weight (kg)
				Liquid Line Temperature °C			
24°C	52°C						
872-NMS	2	DRI-COR Filter Drier	164	117	83	127	0.30
873-NMS	3		738	441	314	229	0.96
876-NMS	4 1/4		1788	1069	760	267	2.18
875-NMS	5		820	1038	733	127	1.50

NOTES

NOTES

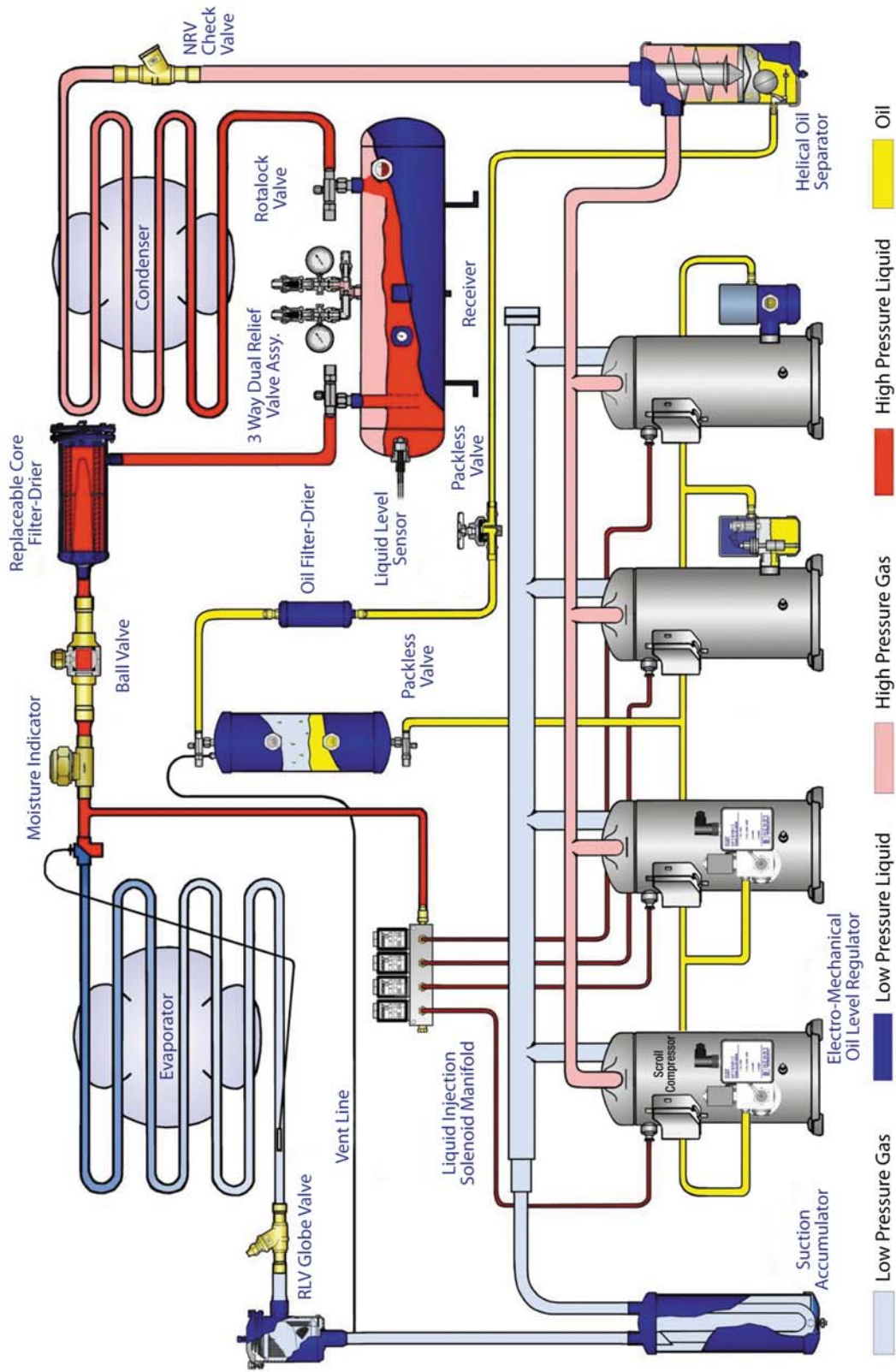



HENRY

Henry Technologies | 76 Mossland Road | Hillington Park | Glasgow | G52 4XZ | Scotland | UK



Tel. +44 141 882 4621 • Fax. +44 141 810 9199

enquiries@henrytech.co.uk • www.henrytech.co.uk

