

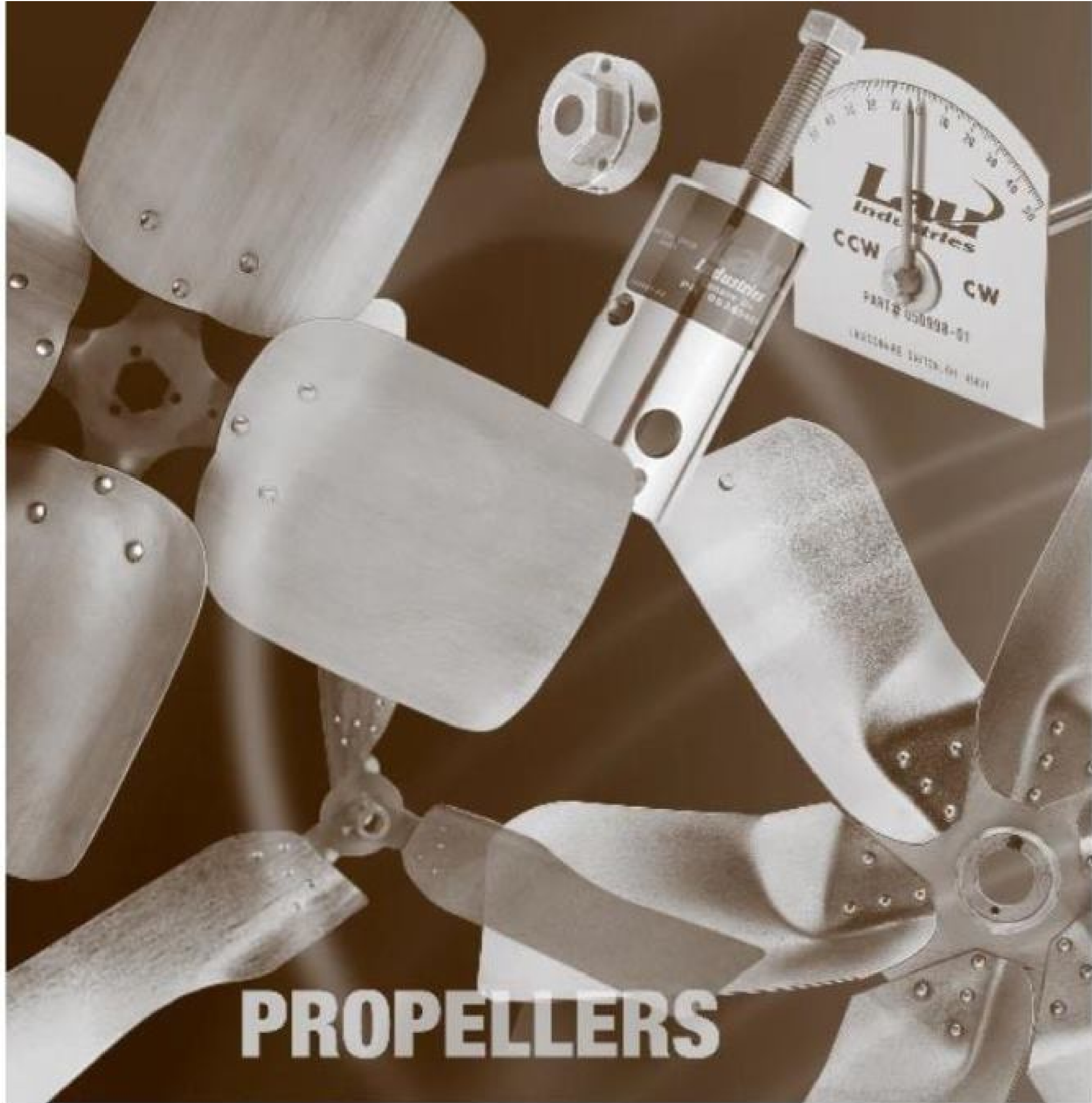

Law

Moving Air is Our Business!



PROPELLERS



BLOWERS



Gates

your

DIRECT SOURCE

for residential and commercial HVAC component replacement parts

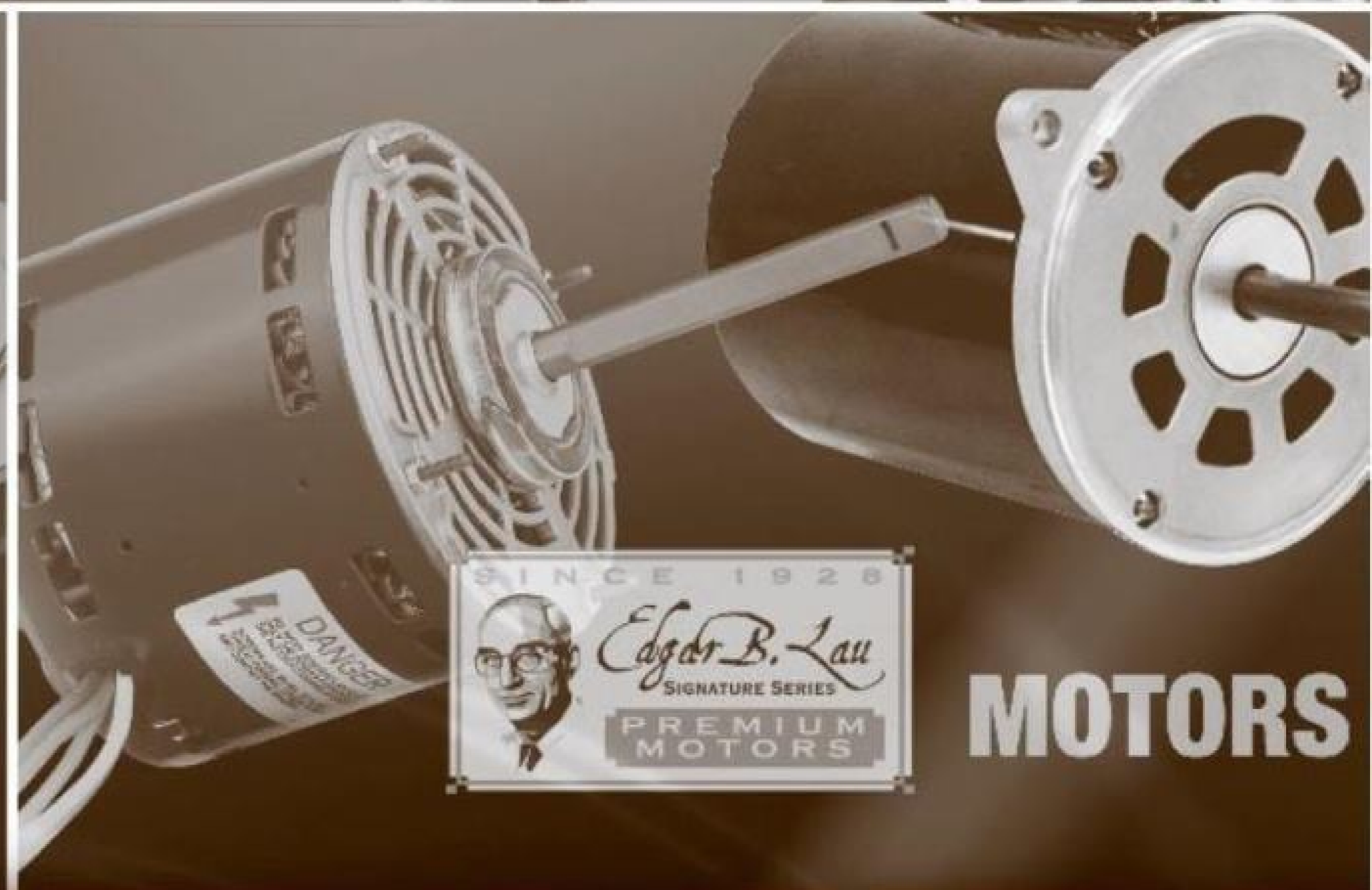

MOTORS

937.253.2000



DAMPERS



LOUVERS



A Perfect Solution to a Variety of Applications

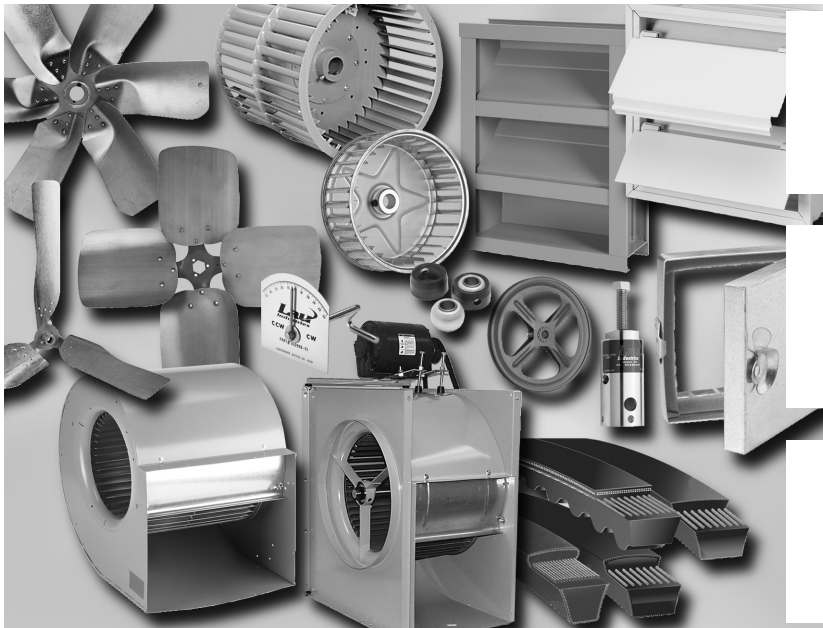

Lau is the Only Manufacturer in the Market Dedicated to the Replacement Business

We specialize in offering a diverse line of residential and commercial HVAC components unparalleled by any other air moving manufacturer. With the recent addition of Fire/Life Safety Products, Control Dampers, Louvers, Ventilation and Property Maintenance products, Lau now offers the most complete line of air moving and related products in the replacement market.

We are in the Urgency Business

When equipment goes down, you need replacement parts fast. We offer the most complete selection of inventory in the industry, shipped from three regional warehouses, at competitive prices.

For more information about Lau products and services, go to www.lauparts.com.

Choose Lau for Superior Service and Support

- Friendly, Knowledgeable Customer Service.** Lau customer service reps are available at each of our three warehouses to serve you. We also have regional sales rep agencies for those times when you need to speak to someone face-to-face. To find out the regional sales rep for your area, go to www.lauparts.com
- Technical Support.** Lau's Engineering staff can assist you with your most difficult application issues. Lau products are continuously tested in our AMCA licensed engineering lab facility for the most up-to-date performance data.
- 3 Warehouses for Faster Service.** The majority of our products **ship from stock within 24 hours** of receipt of your order. We have warehouses in Dayton, Ohio; Mira Loma, California; and Dallas, Texas, to help minimize in-transit time.
- Product Selection.** Our product selection can't be beat! We offer the most complete line of Blowers, Propellers, Service Tools, Fire/Life Safety Products, Control Dampers and Louvers in the industry.
- Lau Express Program for Built-to-Order Products.** Next day, 3-day and 5-day Express options for Fire/Life Safety Products, Control Dampers and Louvers ensure your order will be available to ship when you need it.
- Special Quoting Services.** Don't see what you need in our catalog? Call us for pricing and availability of special Propellers, Blowers and Blower Wheels. We also offer quoting services for our Fire/Life Safety, Control Damper and Louver, and Ventilation product lines.
- Customer Training.** Lau recently completed construction of a new Training Center and Product Showroom. Send your sales personnel to us for the best training in the industry.
- Online Product Literature.** Our product catalogs and technical literature are available online at www.lauparts.com. Call us to order printed copies of product catalogs, installation instructions, and our popular blower and prop posters.

CUSTOMER SERVICE



TECHNICAL SUPPORT



3 WAREHOUSES



Premium Products

Lau is the most diverse and dependable full line supplier of component products and fan systems to residential and commercial heating and cooling markets.

The precise work we do on custom spec components often outlive the equipment manufacturer's original product design. In fact, it is not surprising to find our client companies changing their equipment designs more frequently than our components.

Since each customer has unique requirements, we provide special programs to match your specific needs.



No other
domestic air-moving manufacturer
offers such a diverse
product line of
residential and commercial
air moving component products.



Propellers



General Information	7
2-Blade Propellers	
OEM-Style with Fixed Hub	8
3-Blade Propellers	
Free Air.....	9
Condenser Style, Heavy Duty.....	10-12
Large Steel, Heavy Duty	13
4-Blade Propellers	
Free Air.....	14
Condenser Style, Heavy Duty.....	15-19
Large Steel, Heavy Duty	20
Large Steel, Extra Heavy Duty.....	20
5-Blade Propellers	
Condenser Style, Heavy Duty.....	21-22
6-Blade Propellers	
Large Steel, Heavy Duty	23
Large Steel, Extra Heavy Duty.....	23
Agricultural Propellers	
3-Blade, Stainless Steel & Aluminum	24
Cobra Blade	
2-Blade.....	25
3-Blade.....	26
4-Blade.....	26
OEM "Econoflow" Propellers	27
One Piece Propellers, Aluminum	28-29
Propeller Accessories	
Split Tapered Bushings.....	30
Interchangeable Hubs.....	30
Hub Pullers.....	31
Rainshields.....	32
Pitch Gauge	32
Allen Head Screws.....	32
Replacing a 3-Blade Propeller with a 4 or 5-Blade Propeller	33
Frequently Asked Questions	33

Blowers



General Information	34-35
How to Replace a Blower	35
Belt Drive Blowers	36-37
Blower Selection Procedure.....	37
Twin Blower Parts Kit.....	37
Vibro-Pads.....	37

Continued on next page

TABLE OF CONTENTS



Direct Drive Blowers..... 38
 Performance Data 39



Blower Wheels

Single Inlet
 Galvanized..... 40-43
 Steel Shaft Adapter Bushings 43
 FGP & BD Series 44

Double Inlet
 Aluminum with Steel Hubs..... 45
 Direct Drive 46-47
 Belt Drive..... 48-49
 Reducing Bushings 49
 Belt Drive, Large 50-51

FGP Series..... 52
 Discharge Positions 52

Blower Parts & Accessories
 Replacement Parts..... 53-54
 Component Limits for Blower Accessories 54
 Brackets & Bracket Kits 55
 Bearings 56-58
 How to Install a Self-Locking Collar
 on Sealed & Pillow Block Bearings 58
 Installation Parts
 Thrust Sleeve, Spacer & Collar Kits 59
 Motor Mounting Hardware & Adjustment Kits 59
 Motor Adjustment Grommets..... 59
 Shafts 59
 Vibro-Pads 59

Torque Guide Chart 60



Gates Belts

General Information..... 61
Hi-Power® II – Heavy Duty
 A Belts..... 62-63
 B Belts..... 63-64
 C Belts..... 65-66
 D & E Belts..... 66
Power Curve® II – Heavy Duty
 B Belts..... 67
Tri-Power® – Heavy Duty
 AX Belts..... 68-69
 BX Belts 69-70
 CX Belts 70
Truflex® – Light Duty
 2L Belts 71
 3L Belts 72

4L Belts 73
 5L Belts 74

Super HC® – Heavy Duty
 3V Belts 75
 5V Belts 76
 8V Belts 76

Super HC® “Notched” – Heavy Duty
 3VX Belts 77
 5VX Belts 78



Gates Pulleys

One Groove, Light Duty
 3L & 4L (Bored to Size)..... 79
 4L & 5L (Bored to Size)..... 80
 3L-4L & 5L (Variable Pitch) 83
 3L & 4L (Taper Bushed) 84
 4L & 5L (Taper Bushed) 85

Two Groove, Light Duty
 3L & 4L (Bored to Size)..... 81
 4L & 5L (Bored to Size)..... 82
 3L-4L & 5L (Variable Pitch) 83
 3L & 4L (Taper Bushed) 86
 4L & 5L (Taper Bushed) 86

Tension Testers 87



Motors

General Information..... 88
Edgar B. Lau Signature Series Premium Motors
 Direct Drive Furnace Motors..... 89-90
 1/2 - 1/6 HP 89
 3/4 - 1/5 HP 90
 Condenser Fan Motors 91

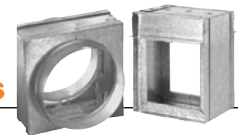

Fire/Life Safety Dampers

Fire Damper Basics & Installation Requirements 92-93
 Curtain Type Dynamic & Static Fire Dampers 94-95
Smoke Damper Basics 96
Fire/Smoke Combination Damper Basics 96-97
FM Global Insurance 98
Quick Reference Chart 99-100
Dynamic Fire Dampers
 1½ Hour Rating 101-111

Specifications are subject to change without notice or obligation

3 Hour Rating 112-117
 Assembly & Dimensional Information 118-122

Static Fire Dampers

1½ Hour Rating 123-131
 3 Hour Rating 132-137

Ceiling Radiation Dampers

General Information 138
 Surface Mount 139
 CCD7 & CCD7-T - For Wood Truss
 Applications 141-145
 UL Floor to Ceiling Comparison Chart 143
 CCD8 - Masonry Applications 144
 Diffuser Radiation Shields 145

Fire/Smoke Combination Dampers

General Information 146
 1½ Hour UL555S Rated 147-153
 Space Envelopes & Dimensional Data 151
 1 Hour UL555S Rated, Corridor Dampers 154-156
 Required Mounting Angles 156
 Actuator Limitation Chart 156

Smoke Dampers

UL555S Classified 157-159



Access Doors

Standard 160
 Quick Fit 161
 Milcor 162

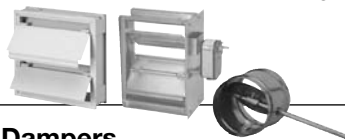

Air Flow Dampers

Commercial Control Dampers

Low Leakage
 Galvanized Steel 163
 High Performance Airfoil 164-165
 Extruded Aluminum 166-167
 Standard Galvanized Steel 168
 Round 169
 Heavy Duty 170

Manual Balancing Dampers

Economy 171
 Single Blade 172

Backdraft Dampers

Galvanized 173
 Aluminum
 Light & Medium Duty 174
 Heavy Duty 175

Counter Balanced Aluminum
 Light Duty 176
 Medium Duty 177
 Heavy Duty 178
 Round 179



Damper Accessories

Fire & Smoke Damper Actuators

CFS1 & CFS2 181-182

Replacement Fuse Links

Styles A, B & J 183

Integral Sleeve & Retaining Angles

FAST & PFMA 184

Flow Duct Smoke Detector

..... 185-188

No Flow Duct Smoke Detector

..... 189-192

TS150 FireStat

..... 193

MCP Control Panels

MCP 1 & 14, MCP 2 & 24 194

MCP10, 104, 20 & 204 195

SP100 Switch Plate

..... 196-197

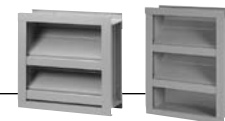

Louvers

General Information

..... 198

Thin Line Stationary

CSE20 199

CSE20D 200

General Purpose Stationary

CSE800 201

CSE800D - Drainable 202

High Performance Stationary

CSE400 203

CSE400D - Drainable 204

CSE400 & CSE400D - Performance Data 205

CSE600 206

CSE600D - Drainable 207

Combination

CL600DX - Drainable 208-209

CL400D - Drainable 210-211

Adjustable

AL600D - Drainable 212-213

Continued on next page

Specifications are subject to change without notice or obligation

Air Curtains



General Information	214
LAD Series (without Electric Heater)	215
LHAD Series (with Electric Heater)	216
LAD & LHAD Series Reference Charts	217
Motors, Heaters, & Control Box Data.....	217
LHAD-36.....	217
LHAD-42.....	217
LHAD-48.....	217
LHAD-64.....	217
LHAD-78.....	217
LHAD-84.....	217
Air Flow & Sound Performance Data.....	217
LAD-36.....	217
LAD-42.....	217
LAD-48.....	217
LAD-64.....	217
LAD-78.....	217
LAD-84.....	217
LAD & LHAD Suggested Specifications	218

Appendix

Appendix A

Propellers	
Performance Charts	
2-Blade Fixed Hub.....	219
3-Blade Free Air.....	220
4-Blade Free Air.....	220-221
3-Blade Heavy Duty Condenser Style.....	221-223
4-Blade Heavy Duty Condenser Style.....	224-227
5-Blade Heavy Duty Condenser Style.....	228-230
3-Blade Large Heavy Duty Steel.....	230
4-Blade Large Heavy Duty Steel.....	230-231
6-Blade Large Heavy Duty Steel.....	231
4-Blade Large Extra Heavy Duty Steel.....	232
6-Blade Large Extra Heavy Duty Steel.....	232
2-Blade, Cobra.....	233
3-Blade, Cobra.....	234
4-Blade, Cobra.....	235
Cobra Blade Cross Reference.....	236

Appendix B

Belt Drive Blowers	
Performance Charts.....	237-238
RPM Drive Chart.....	239
FGP Series Blowers	
Dimensional Data.....	240
Performance Charts.....	241-243
Drive Charts & Guidelines.....	244-246

Appendix C

Dampers - Operation & Maintenance Instructions	
Dynamic & Static Curtain Type Fire Dampers.....	247
Smoke Dampers	
CSD36, CSD37 & CSDRS25.....	247
Fire/Smoke Dampers.....	247
CFS1 & CFS2.....	247

Appendix D

OEM Cross Reference.....	249-286
--------------------------	---------

Index

By Part Number.....	287-314
---------------------	---------



Edgar B. Lau

*“Exceeding our customer expectations
is not only part of our job ... it’s part of our culture.”*

WHY INSTALL A NEW PROPELLER?

Propeller balance is sensitive and can be negatively affected by slight pressure. Simply resting the motor and propeller assembly on the ground after disassembly from a condensing unit can make a propeller unbalanced. This is especially true of original equipment propellers because they are constructed of lighter gauge material. Using an unbalanced or damaged propeller can ruin a motor.

Lau Heavy Duty Replacement Propellers are designed to hold their balance in the toughest applications. It is less expensive to install a new Lau Heavy Duty Replacement Propeller than replace a damaged motor.

IDENTIFYING PROPELLER ROTATION

The Sandbox method is an easy method of determining rotation. Imagine standing in a sandbox and dropping the propeller on the sand. Regardless of which side is up, the direction of rotation is the same as the direction required to turn the propeller into the sand.

REPLACING A PROPELLER

1. Disconnect electrical power.
2. Note the location of the current propeller in the unit. Remove current propeller from motor shaft with the proper type of puller.
3. Remove burrs and/or rust from motor shaft.
4. Locate interchangeable hub on desired side of propeller. Attach hub to propeller with three screws. Tighten screws to approximately 30 in-lbs.
5. Place propeller on motor shaft in the unit, place the propeller in approximately the same position as the old propeller.
6. Make sure that the propeller will be rotating in the correct direction.
7. Fasten the propeller to the motor shaft by tightening set screws securely. Be sure to align setscrew on flat of the motor shaft.
8. Rotate the propeller by hand to make sure that the blades clear any obstructions by at least 1/4".

PROPELLER TABLE OF CONTENTS

General Information	7
2-Blade (OEM-Style with Fixed Hub)	8
3-Blade	
Free Air	9
Condenser Style, Heavy Duty	10-12
Large Steel, Heavy Duty	13
4-Blade	
Free Air	14
Condenser Style, Heavy Duty	15-19
Large Steel, Heavy Duty	20
Large Steel, Extra Heavy Duty	20
5-Blade	
Condenser Style, Heavy Duty	21-22
6-Blade	
Large Steel Heavy Duty	23
Large Steel Extra Heavy Duty	23
Agricultural (Stainless Steel & Aluminum)	24
Cobra Blade (2-Blade – 4-Blade)	25-26
OEM "Econoflow" Propellers	27
One Piece Propellers	28-29
Propeller Accessories	
Split Tapered Bushings	30
Interchangeable Hubs	31
Hub Pullers	32
Rainshields	32
Pitch Gauge	32
Allen Head Screws	32
How to Replace a 3-Blade Propeller with a 4 or 5-Blade Propeller	33
Frequently Asked Questions	33

2-BLADE PROPELLERS

OEM-Style with Fixed Hub



Application: Condensers

For performance information please refer to Appendix A



- **High quality aluminum blades with corrosion-resistant center spiders**

Lau Universal Replacement Propellers are 100% inspected and precision balanced. Identification labels are applied to blades BEFORE balancing. Removal of a Lau label and/or adding additional labels to propeller blades can affect balance.

2-BLADE PROPELLERS

Diameter (inches)	Part Number	Rotation	Pitch	Hub Location	Bore Size	Quantity Pack
14"	6130470001	CW	32°	Discharge	1/2"	2
14"	6130460001	CCW	36°	Intake	1/2"	2
14"	60743401	CW	36°	Discharge	1/2"	2
18"	6130490001	CCW	19°	Intake	1/2"	2
18"	6130500001	CW	24°	Intake	1/2"	2
18"	60772501	CCW	28°	Intake	1/2"	2
18"	6130510001	CW	29°	Intake	1/2"	2
18"	60652101	CCW	32°	Intake	1/2"	2
18"	6130520001	CW	36°	Intake	1/2"	2
20"	6130530001	CCW	23°	Intake	1/2"	2
20"	6130540001	CCW	25°	Intake	1/2"	2
20"	60772601	CCW	28°	Intake	1/2"	2
20"	6130560001	CW	28°	Intake	1/2"	2
20"	6130550001	CCW	34°	Intake	1/2"	2
22"	60772701	CCW	16°	Intake	1/2"	2
22"	6128990001	CCW	21°	Intake	1/2"	2
22"	60814201	CCW	27°	Intake	1/2"	2
24"	6130570001	CCW	19°	Intake	1/2"	2
24"	61040201	CCW	22°	Intake	1/2"	2
24"	6130580001	CCW	24°	Intake	1/2"	2
24"	60772801	CCW	27°	Intake	1/2"	2

CW = Clockwise Rotation

CCW = Counter-Clockwise Rotation

Specifications are subject to change without notice or obligation

Applications: Pedestal & Window Fans, Air Circulators

For performance information please refer to Appendix A

- **Designed for free air, low pressure applications**
- **High quality, rounded aluminum blades for maximum free air delivery with minimum noise levels**
- **Pitches available for most common HP and motor speeds**
- **Hubs attach on either the intake or discharge side**

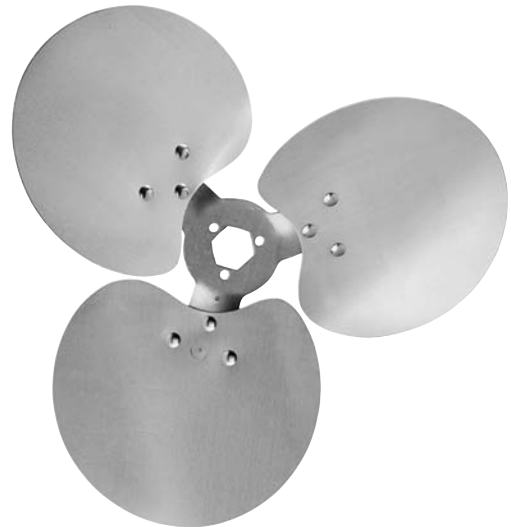

FREE AIR PROPELLERS

Diameter (inches)	Part Number	Rotation	Pitch	Hub Location	Quantity Pack
*10"	60265201	CW	27°	Interchangeable	2
*10"	60265301	CCW	27°	Interchangeable	2
12"	60265401	CW	23°	Interchangeable	2
12"	60265501	CCW	23°	Interchangeable	2
14"	60265801	CW	23°	Interchangeable	2
14"	60265901	CCW	23°	Interchangeable	2
16"	60266201	CW	23°	Interchangeable	2
16"	60266301	CCW	23°	Interchangeable	2
18"	60555901	CW	23°	Interchangeable	2
18"	60556001	CCW	23°	Interchangeable	2
20"	60267001	CW	23°	Interchangeable	2
20"	60267101	CCW	23°	Interchangeable	2
24"	60267601	CW	18°	Interchangeable	2

* Square blade, not round

INTERCHANGEABLE HUBS FOR 3-BLADE, FREE AIR PROPELLERS

(Order Separately)

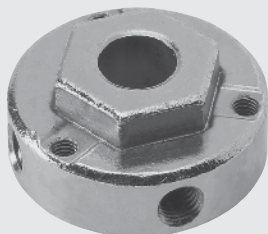

Part Number	Bore	Set Screw
60765801	1/4"	1
60765802	5/16"	1
60765803	3/8"	1
60765804	1/2"	2
60765805	5/8"	2
60765806	3/4"	2



Call your Customer Service Representative today for more information!!

Specifications are subject to change without notice or obligation

3-BLADE PROPELLERS

Heavy Duty Condenser Style



Applications: Condensing Units, Building & Agricultural Ventilation Fans

For performance information please refer to Appendix A

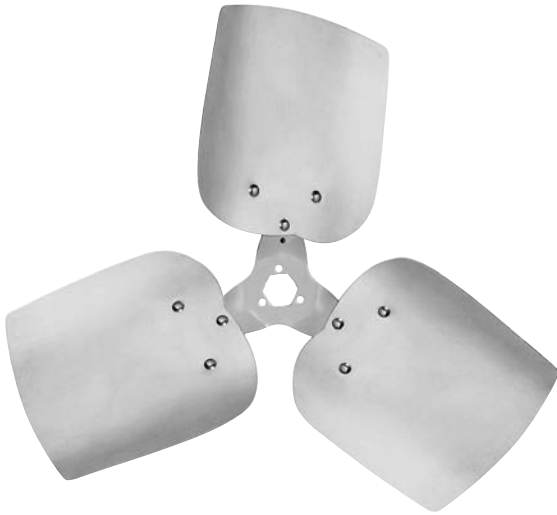

- **High strength aluminum blades with corrosion-resistant center spiders**

Measure the correct pitch & rotation direction with a Lau Pitch Gauge



Part #05099801

CONDENSER STYLE, HEAVY DUTY PROPELLERS

Diameter (inches)	Part Number	Rotation	Pitch	Hub Location	Bore Size	Quantity Pack
10"	6129770001	CW	23°	Interchangeable		2
10"	6129760001	CCW	23°	Interchangeable		2
12"	60716101	CW	19°	Interchangeable		2
12"	60716201	CCW	19°	Interchangeable		2
12"	60716301	CW	23°	Interchangeable		2
12"	60716401	CCW	23°	Interchangeable		2
12"	6129790001	CW	27°	Interchangeable		2
12"	6129780001	CCW	27°	Interchangeable		2
14"	60998901	CW	19°	Intake	5/16"	2
14"	60716501	CW	23°	Interchangeable		2
14"	60716601	CCW	23°	Interchangeable		2
14"	60716701	CW	27°	Interchangeable		2
14"	60716801	CCW	27°	Interchangeable		2
16"	60716901	CW	19°	Interchangeable		2
16"	60717001	CCW	19°	Interchangeable		2
16"	60717101	CW	23°	Interchangeable		2
16"	60717201	CCW	23°	Interchangeable		2
16"	6129810001	CW	27°	Interchangeable		2
16"	6129800001	CCW	27°	Interchangeable		2
18"	6130590001	CW	19°	Discharge	1/2"	2

Specifications are subject to change without notice or obligation

CONDENSER STYLE, HEAVY DUTY PROPELLERS, CON'T.

Diameter (inches)	Part Number	Rotation	Pitch	Hub Location	Bore Size	Quantity Pack
18"	6130600001	CCW	22°	Intake	1/2"	2
18"	60556001	CCW	23°	Interchangeable		2
18"	6130610001	CW	26°	Discharge	1/2"	2
18"	60556101	CW	27°	Interchangeable		2
18"	60556201	CCW	27°	Interchangeable		2
18"	60556301	CW	30°	Interchangeable		2
18"	60556401	CCW	30°	Interchangeable		2
18"	60556501	CW	33°	Interchangeable		2
18"	60556601	CCW	33°	Interchangeable		2
18"	6130620001	CCW	35°	Intake	1/2"	2
20"	60870301	CW	21°	Discharge	1/2"	2
20"	6129830001	CW	24°	Interchangeable		2
20"	6129820001	CCW	24°	Interchangeable		2
20"	60999001	CCW	25°	Intake	1/2"	2
20"	60556701	CW	27°	Interchangeable		2
20"	60556801	CCW	27°	Interchangeable		2
20"	60556901	CW	30°	Interchangeable		2
20"	60557001	CCW	30°	Interchangeable		2
20"	6130630001	CW	31°	Discharge	1/2"	2
20"	60557101	CW	33°	Interchangeable		2
20"	60557201	CCW	33°	Interchangeable		2
22"	6129570001	CW	20°	Intake	1/2"	2
22"	6130640001	CW	24°	Intake	1/2"	2
22"	60557301	CW	27°	Interchangeable		2
22"	60557401	CCW	27°	Interchangeable		2
22"	6130650001	CW	28°	Intake	1/2"	2
22"	6129850001	CW	30°	Interchangeable		2
22"	6129840001	CCW	30°	Interchangeable		2
22"	60557501	CW	33°	Interchangeable		2
22"	60557601	CCW	33°	Interchangeable		2
22"	6129870001	CW	35°	Interchangeable		2
22"	6129860001	CCW	35°	Interchangeable		2
24"	6131430001	CW	22°	Intake	1/2"	2
24"	60557701	CW	27°	Interchangeable		2

Specifications are subject to change without notice or obligation

3-BLADE PROPELLERS

Condenser Style, Heavy Duty



Applications: Condensing Units, Building & Agricultural Ventilation Fans

For performance information please refer to Appendix A

CONDENSER STYLE, HEAVY DUTY PROPELLERS, CON'T.

Diameter (inches)	Part Number	Rotation	Pitch	Hub Location	Bore Size	Quantity Pack
24"	60557801	CCW	27°	Interchangeable		2
24"	6128230001	CW	30°	Intake	1/2"	2
24"	60557901	CW	33°	Interchangeable		2
24"	60558001	CCW	33°	Interchangeable		2
26"	61046601	CW	26°	Discharge	1/2"	1
26"	6129890001	CW	26°	Interchangeable		1
26"	6129880001	CCW	26°	Interchangeable		1
26"	6129910001	CW	33°	Interchangeable		1
26"	6129900001	CCW	33°	Interchangeable		1
26"	6130660001	CW	37°	Intake	1/2"	1
30"	6129920001	CCW	27°	Interchangeable		1
30"	6129930001	CW	27°	Interchangeable		1
30"	6129940001	CCW	33°	Interchangeable		1
30"	6129950001	CW	33°	Interchangeable		1

CW = Clockwise Rotation
CCW = Counter-Clockwise Rotation

INTERCHANGEABLE HUBS FOR 3-BLADE PROPELLERS

(Order Separately)

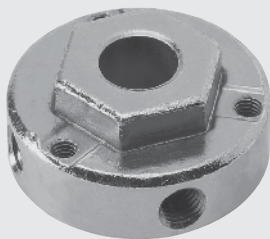

Part Number	Bore	Set Screw
60765801	1/4"	1
60765802	5/16"	1
60765803	3/8"	1
60765804	1/2"	2
60765805	5/8"	2
60765806	3/4"	2

REMOVE FAN BLADES & BLOWER WHEELS EASILY WITH LAU'S HUB PULLERS

Use for Heavy Duty Applications



Part No.
05214101

Use for General Duty Applications



Part No.
05380401

See Page 32 for usage directions and to find replacement parts.

DID YOU KNOW?

Numerous sizes and styles of all steel propellers through 96" are available on a special order basis.

Call for more information about the ...

Number of Blades, Diameter, Bore Size, Motor Horsepower, Fan RPM and Application (where and how used).

Specifications are subject to change without notice or obligation

Applications: Industrial Circulators, Condensing Units, Cooling Towers & Agricultural Ventilation

For performance information please refer to Appendix A

- **Heavy duty mill galvalume blades and painted steel spider**

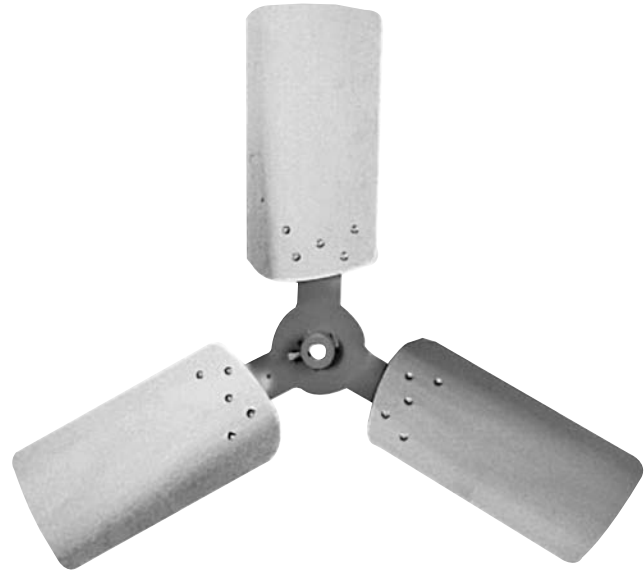
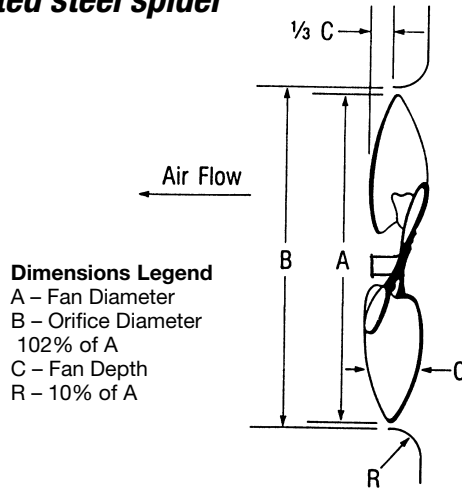

LARGE STEEL PROPELLERS - HEAVY DUTY SERIES

Dia. (inches)	Part Number	Replaces	Pitch	Rotation	Blade Depth	Blade Width	Max. RPM	Weight
30"	61093601	60565301	22°	CW	2 ⁷ / ₈ "	6"	1140	7
30"	61093701	60565401	27°	CW	2 ⁷ / ₈ "	6"	1140	7
36"	61093801	60565501	27°	CW	2 ⁷ / ₈ "	6"	1000	8
36"	61093901	60565601	33°	CW	3 ³ / ₈ "	6"	1000	8

SPLIT TAPERED BUSHINGS FOR DESIRED BORE SIZE

- **For 1/2" through 1⁷/₁₆" bore range**
- **Steel construction**

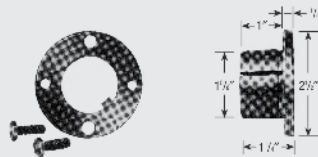

H-STYLE

(FOR 24" -48" PROPELLERS)

Part No.	Bore
60331504	1/2"
60331505	5/8"
60331506	3/4"
60331507	7/8"
60331508	1"
60331501	1 1/8"
60331502	1 3/16"
60331509	1 1/4"
60331503	1 3/8"



P-STYLE

(FOR 54" -60" PROPELLERS)

Part No.	Bore
72513808	1"
72513809	1 1/8"
72513810	1 1/4"
72513811	1 3/8"
72513812	1 3/16"
72513813	1 5/8"
72513815	1 7/16"

Standard Keyway Sizes	
Diameter of Shaft	Keyseat Width X Depth
5/16 - 3/16	3/32 X 3/64
1/2 - 9/16	1/8 X 1/16
5/8 - 7/8	3/16 X 3/32
1 1/16 - 1 1/4	1/4 X 1/8
1 5/16 - 1 3/8	5/16 X 5/32
1 7/16 - 1 1/4	3/8 X 3/16
1 13/16 - 2 1/4	1/2 X 1/4

Measurements in inches.

Split Tapered Bushings must be ordered separately

4-BLADE PROPELLERS

Free Air



Applications: Circulators, Pedestal & Window Fans

For performance information please refer to Appendix A

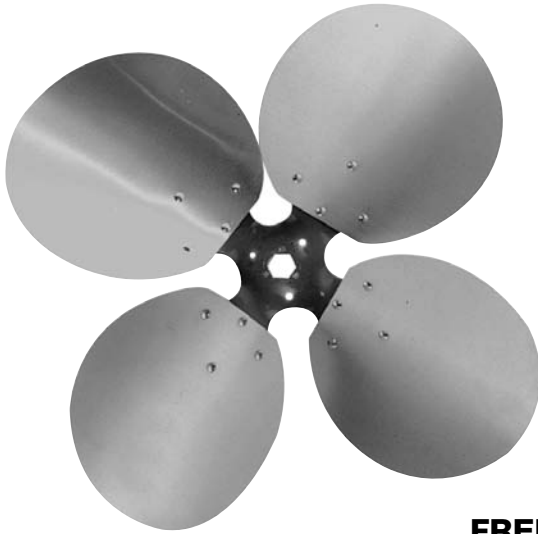

- **Designed for free air, low pressure applications**
- **High quality, rounded aluminum blades for maximum free air delivery with minimum noise levels**
- **Pitches available for most common HP and motor speeds**
- **Interchangeable hubs attach on either the intake or discharge side**

FREE AIR PROPELLERS

Diameter (inches)	Part Number	Rotation	Pitch	Hub Location	Quantity Pack
10"	60269301	CW	23°	Interchangeable	2
10"	60269401	CCW	23°	Interchangeable	2
12"	60262201	CW	23°	Interchangeable	2
12"	60262301	CCW	23°	Interchangeable	2
14"	60262801	CW	27°	Interchangeable	2
14"	60262901	CCW	27°	Interchangeable	2
18"	60555301	CW	23°	Interchangeable	2
18"	60555401	CCW	23°	Interchangeable	2
18"	60555501	CW	27°	Interchangeable	2
18"	60555601	CCW	27°	Interchangeable	2
20"	60263801	CW	23°	Interchangeable	2
20"	60263901	CCW	23°	Interchangeable	2
20"	60264001	CW	27°	Interchangeable	2
20"	60264101	CCW	27°	Interchangeable	2
20"	60285301	CW	33°	Interchangeable	2
20"	60285401	CCW	33°	Interchangeable	2
24"	60562101	CW	18°	Interchangeable	2
24"	60562201	CCW	18°	Interchangeable	2
24"	60562301	CW	23°	Interchangeable	2
24"	60562401	CCW	23°	Interchangeable	2
24"	60562501	CW	27°	Interchangeable	2
24"	60562601	CCW	27°	Interchangeable	2

CW = Clockwise Rotation

CCW = Counter-Clockwise Rotation

Specifications are subject to change without notice or obligation

Applications: Condensing Units, General Building & Agricultural Ventilation Fans

- **High strength aluminum blades with corrosion-resistant center spiders**

LAU PROPELLERS ARE AVAILABLE FROM STOCK THROUGH OUR VAST NETWORK OF WHOLESALERS THROUGHOUT THE USA.

INTERCHANGEABLE HUBS FOR 4-BLADE PROPELLERS
(Order Separately)

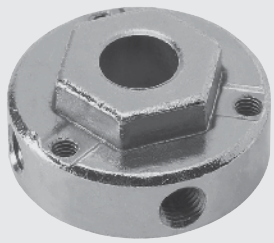

Part Number	Bore	Set Screw
60765801	1/4"	1
60765802	5/16"	1
60765803	3/8"	1
60765804	1/2"	2
60765805	5/8"	2
60765806	3/4"	2

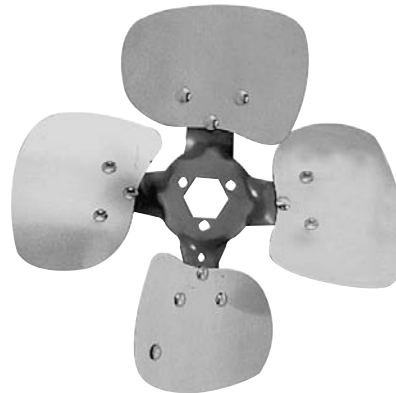

10" - 12"



14" - 20"

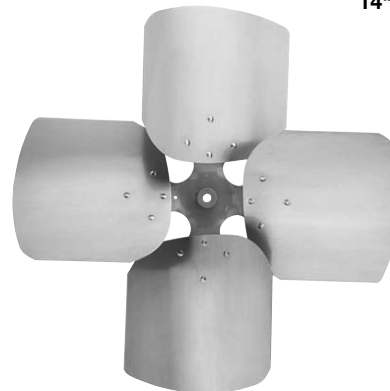

22" - 24"

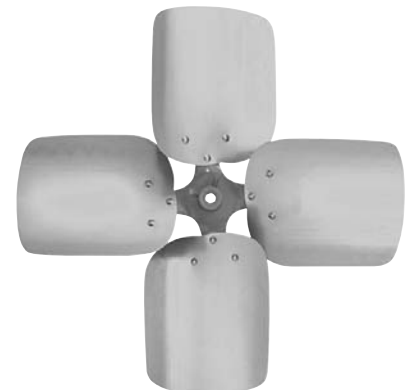

26" - 30"

DID YOU KNOW?

You can replace a 4-blade condenser fan with a 5-blade fan?

If you do this, choose a replacement that matches the CFM required as closely as possible.

Ensure the brake HP required does not exceed the nameplate rating of the motor!

 For directions, see Page 33

Specifications are subject to change without notice or obligation

4-BLADE**Condenser Style, Heavy Duty**

Applications: Condensing Units, General Building & Agricultural Ventilation Fans

For performance information please refer to Appendix A

CONDENSER STYLE, HEAVY DUTY PROPELLERS

Diameter (inches)	Part Number	Rotation	Pitch	Hub Location	Quantity Pack
10"	6129970001	CW	16°	Interchangeable	2
10"	6129960001	CCW	16°	Interchangeable	2
10"	60717301	CW	19°	Interchangeable	2
10"	60717401	CCW	19°	Interchangeable	2
10"	60717501	CW	23°	Interchangeable	2
10"	60717601	CCW	23°	Interchangeable	2
10"	60717701	CW	27°	Interchangeable	2
10"	60717801	CCW	27°	Interchangeable	2
10"	60759901	CW	33°	Interchangeable	2
10"	60760001	CCW	33°	Interchangeable	2
12"	6129990001	CW	16°	Interchangeable	2
12"	6129980001	CCW	16°	Interchangeable	2
12"	60717901	CW	19°	Interchangeable	2
12"	60718001	CCW	19°	Interchangeable	2
12"	60718101	CW	23°	Interchangeable	2
12"	60718201	CCW	23°	Interchangeable	2
12"	60718301	CW	27°	Interchangeable	2
12"	60718401	CCW	27°	Interchangeable	2
12"	60760101	CW	33°	Interchangeable	2
12"	60760201	CCW	33°	Interchangeable	2
14"	6130010001	CW	16°	Interchangeable	2
14"	6130000001	CCW	16°	Interchangeable	2
14"	60718501	CW	19°	Interchangeable	2
14"	60718601	CCW	19°	Interchangeable	2
14"	60718701	CW	23°	Interchangeable	2
14"	60718801	CCW	23°	Interchangeable	2
14"	60718901	CW	27°	Interchangeable	2
14"	60719001	CCW	27°	Interchangeable	2
14"	60760301	CW	33°	Interchangeable	2
14"	60760401	CCW	33°	Interchangeable	2
16"	60719101	CW	19°	Interchangeable	2
16"	60719201	CCW	19°	Interchangeable	2
16"	60719301	CW	23°	Interchangeable	2

Specifications are subject to change without notice or obligation

Applications: Condensing Units, General Building & Agricultural Ventilation Fans

For performance information please refer to Appendix A

CONDENSER STYLE, HEAVY DUTY PROPELLERS, CON'T.

Diameter (inches)	Part Number	Rotation	Pitch	Hub Location	Bore Size	Quantity Pack
16"	60719401	CCW	23°	Interchangeable		2
16"	60719501	CW	27°	Interchangeable		2
16"	60719601	CCW	27°	Interchangeable		2
16"	60760501	CW	33°	Interchangeable		2
16"	60760601	CCW	33°	Interchangeable		2
18"	6130030001	CW	16°	Interchangeable		2
18"	6130020001	CCW	16°	Interchangeable		2
18"	6130050001	CW	19°	Interchangeable		2
18"	6130040001	CCW	19°	Interchangeable		2
18"	60800201	CW	23°	Interchangeable		2
18"	60800301	CCW	23°	Interchangeable		2
18"	60558101	CW	27°	Interchangeable		2
18"	60558201	CCW	27°	Interchangeable		2
18"	60558301	CW	30°	Interchangeable		2
18"	60558401	CCW	30°	Interchangeable		2
18"	60558501	CW	33°	Interchangeable		2
18"	60558601	CCW	33°	Interchangeable		2
20"	6130070001	CW	14°	Interchangeable		2
20"	6130060001	CCW	14°	Interchangeable		2
20"	6130090001	CW	17°	Interchangeable		2
20"	6130080001	CCW	17°	Interchangeable		2
20"	6130110001	CW	19°	Interchangeable		2
20"	6130100001	CCW	19°	Interchangeable		2
20"	6130670001	CW	20°	Discharge	1/2"	2
20"	60800401	CW	23°	Interchangeable		2
20"	60800501	CCW	23°	Interchangeable		2
20"	60558701	CW	27°	Interchangeable		2
20"	60558801	CCW	27°	Interchangeable		2
20"	60943601	CW	29°	Discharge	1/2"	2
20"	60558901	CW	30°	Interchangeable		2
20"	60559001	CCW	30°	Interchangeable		2
20"	60559101	CW	33°	Interchangeable		2
20"	60559201	CCW	33°	Interchangeable		2
20"	6130680001	CW	36°	Intake	1/2"	2

Specifications are subject to change without notice or obligation

4-BLADE PROPELLERS

Condenser Style, Heavy Duty



Applications: Condensing Units, General Building & Agricultural Ventilation Fans

For performance information please refer to Appendix A

CONDENSER STYLE, HEAVY DUTY PROPELLERS, CON'T.

Diameter (inches)	Part Number	Rotation	Pitch	Hub Location	Bore Size	Quantity Pack
22"	60804101	CW	23°	Interchangeable		2
22"	60804201	CCW	23°	Interchangeable		2
22"	6130690001	CW	24°	Discharge	1/2"	2
22"	6130700001	CW	26°	Intake	1/2"	2
22"	60559301	CW	27°	Interchangeable		2
22"	60559401	CCW	27°	Interchangeable		2
22"	60841201	CW	30°	Discharge	1/2"	2
22"	60559501	CW	33°	Interchangeable		2
22"	60559601	CCW	33°	Interchangeable		2
22"	6130130001	CW	35°	Interchangeable		2
22"	6130120001	CCW	35°	Interchangeable		2
24"	6130150001	CW	13°	Interchangeable		2
24"	6130140001	CCW	13°	Interchangeable		2
24"	6130170001	CW	16°	Interchangeable		2
24"	6130160001	CCW	16°	Interchangeable		2
24"	6130190001	CW	18°	Interchangeable		2
24"	6130180001	CCW	18°	Interchangeable		2
24"	6131960001	CW	20°	Discharge	1/2"	2
24"	6130210001	CW	20°	Interchangeable		2
24"	6130200001	CCW	20°	Interchangeable		2
24"	60804301	CW	23°	Interchangeable		2
24"	60804401	CCW	23°	Interchangeable		2
24"	60841701	CCW	23°	Intake	1/2"	2
24"	60841501	CW	25°	Discharge	1/2"	2
24"	60559701	CW	27°	Interchangeable		2
24"	60559801	CCW	27°	Interchangeable		2
24"	6130710001	CW	29°	Intake	1/2"	2
24"	60559901	CW	33°	Interchangeable		2
24"	60560001	CCW	33°	Interchangeable		2
26"	60760701	CW	24°	Interchangeable		1
26"	60760801	CCW	24°	Interchangeable		1
26"	60760901	CW	27°	Interchangeable		1
26"	60761001	CCW	27°	Interchangeable		1
26"	60885701	CW	28°	Discharge	1/2"	1

Specifications are subject to change without notice or obligation

Applications: Condensing Units, General Building & Agricultural Ventilation Fans

For performance information please refer to Appendix A

CONDENSER STYLE, HEAVY DUTY PROPELLERS, CON'T.

Diameter (inches)	Part Number	Rotation	Pitch	Hub Location	Bore Size	Quantity Pack
26"	6130720001	CW	30°	Discharge	5/8"	1
26"	60997201	CW	32°	Discharge	5/8"	1
26"	60761101	CW	33°	Interchangeable		1
26"	60761201	CCW	33°	Interchangeable		1
26"	6130730001	CW	38°	Discharge	3/4"	1
28"	61017601	CW	25°	Discharge	5/8"	1
28"	6129170001	CW	29°	Discharge	1/2"	1
28"	6130750001	CW	34°	Discharge	5/8"	1
30"	6130760001	CW	22°	Intake	5/8"	1
30"	60943701	CW	25°	Discharge	5/8"	1
30"	6131250001	CW	27°	Interchangeable		1
30"	6131240001	CCW	27°	Interchangeable		1
30"	6127600001	CW	27°	Discharge	5/8"	1
30"	6127290001	CW	30°	Discharge	5/8"	1
30"	6131260001	CCW	33°	Interchangeable		1
30"	6131270001	CW	33°	Interchangeable		1
30"	6130770001	CW	40°	Intake	5/8"	1

Do not exceed RPM and HP ratings shown in charts (see Appendix A).

Measure the correct pitch & rotation direction with a Lau Pitch Gauge



Remove Fan Blades & Blower Wheels easily with Lau's Hub Pullers

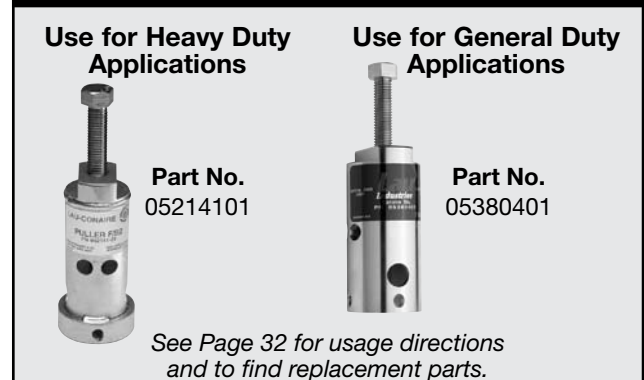

Specifications are subject to change without notice or obligation

4-BLADE PROPELLERS

Large Steel Heavy Duty, Clockwise Rotation



Applications: Industrial Air Circulators, Exhaust Fan & Large Condensing Units and Agricultural Ventilation

For performance information please refer to Appendix A



- High quality, heavy duty mill galvanized steel blades with corrosion-resistant center spiders

DID YOU KNOW?

Various sizes and styles of all steel props through 96" are available on a special order basis.

Call for more information about:

- Number of Blades • Bore Size • Fan RPM • Diameter
- Motor Horsepower • Application (where & usage)

HEAVY DUTY – CLOCKWISE ROTATION

Diameter (inches)	Part Number	Pitch	Blade Depth	Blade Width	Max. RPM	Blade Wt. (lbs.)
24"	60832901	27°	3 $\frac{1}{4}$ "	6 $\frac{1}{2}$ "	1335	6.80
26"	60833001	27°	3 $\frac{3}{8}$ "	6 $\frac{9}{16}$ "	1140	7.00
28"	60833101	27°	4 $\frac{3}{16}$ "	7 $\frac{9}{16}$ "	950	7.80
30"	60833201	27°	4"	7 $\frac{5}{8}$ "	950	8.00
36"	60833301	27°	4 $\frac{5}{16}$ "	8 $\frac{1}{4}$ "	765	12.00
42"	60833401*+	27°	5"	9 $\frac{3}{4}$ "	630	20.00
48"	60833501*+	27°	5 $\frac{3}{8}$ "	10 $\frac{5}{8}$ "	525	25.00
54"	60833601*+	27°	6"	11 $\frac{1}{2}$ "	575	50.00
60"	60833701*+	27°	6"	12 $\frac{1}{2}$ "	525	60.00
60"	60834301*+	40°	7 $\frac{3}{4}$ "	12 $\frac{1}{2}$ "	470	60.00

* Blade width is measured at the widest points of the blade.

+ Must be shipped via common carrier.

EXTRA HEAVY DUTY – CLOCKWISE ROTATION FOR HIGH RPM APPLICATIONS

Diameter (inches)	Part Number	Pitch	Blade Depth	Blade Width	Max. RPM	Blade Wt. (lbs.)
24"	6126890001	27°	3 $\frac{1}{4}$ "	6 $\frac{1}{2}$ "	1640	7.00
26"	6126890002	27°	3 $\frac{3}{8}$ "	6 $\frac{9}{16}$ "	1350	9.00
28"	6126890003	27°	3 $\frac{3}{8}$ "	7 $\frac{1}{16}$ "	1140	10.00
30"	6126890004	27°	4"	7 $\frac{5}{8}$ "	1230	11.00
36"	6126890005	27°	4 $\frac{5}{16}$ "	8 $\frac{1}{4}$ "	905	18.00
42"	6126890006+	27°	5"	9 $\frac{3}{4}$ "	835	25.00
48"	6126890007+	27°	5 $\frac{3}{8}$ "	10 $\frac{5}{8}$ "	685	37.00
54"	6126890008+	27°	6"	11 $\frac{1}{2}$ "	610	59.00
60"	6126890009+	27°	6"	12 $\frac{1}{2}$ "	565	69.00

* Blade width is measured at the widest points of the blade.

+ Must be shipped via common carrier.

Specifications are subject to change without notice or obligation

Applications: Industrial Air Circulators, Exhaust Fan Units & Large Condensing Units

For performance information please refer to Appendix A

- **High quality aluminum blades with corrosion-resistant center spiders**

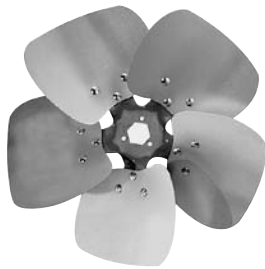

12" - 18" Diameter

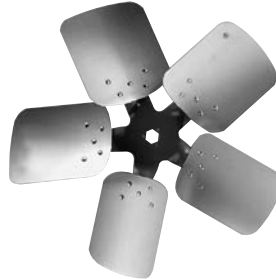

20" - 24" Diameter

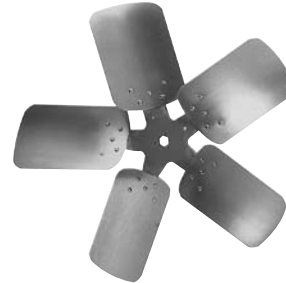

26" Diameter

HEAVY DUTY CONDENSER STYLE

Diameter (inches)	Part Number	Rotation	Pitch	Hub Location	Quantity Pack
10"	60720101	CW	27°	Interchangeable	2
10"	60720201	CCW	27°	Interchangeable	2
12"	60720401	CW	19°	Interchangeable	2
12"	60720501	CW	23°	Interchangeable	2
12"	60720601	CCW	23°	Interchangeable	2
12"	60720701	CW	27°	Interchangeable	2
12"	60720801	CCW	27°	Interchangeable	2
14"	60721101	CW	23°	Interchangeable	2
14"	60721201	CCW	23°	Interchangeable	2
14"	60721301	CW	27°	Interchangeable	2
14"	60721401	CCW	27°	Interchangeable	2
16"	60560101	CW	27°	Interchangeable	2
16"	60560201	CCW	27°	Interchangeable	2
16"	6130220001	CW	29°	Interchangeable	2
16"	6130230001	CCW	29°	Interchangeable	2
16"	60560301	CW	33°	Interchangeable	2
16"	60560401	CCW	33°	Interchangeable	2
18"	6130250001	CW	25°	Interchangeable	2
18"	6130240001	CCW	25°	Interchangeable	2
18"	60560501	CW	27°	Interchangeable	2
18"	60560601	CCW	27°	Interchangeable	2
18"	60560701	CW	33°	Interchangeable	2
18"	60560801	CCW	33°	Interchangeable	2
18"	6130270001	CW	31°	Interchangeable	2
18"	6130260001	CCW	31°	Interchangeable	2

Specifications are subject to change without notice or obligation

5-BLADE PROPELLERS**Condenser Style, Heavy Duty**

**Applications: Industrial Air Circulators,
Exhaust Fan Units & Large Condensing Units**

For performance information please refer to Appendix A

CONDENSER STYLE, HEAVY DUTY, CON'T.

Diameter (inches)	Part Number	Rotation	Pitch	Hub Location	Quantity Pack
20"	60560901	CW	27°	Interchangeable	2
20"	60561001	CCW	27°	Interchangeable	2
20"	6130310001	CW	30°	Interchangeable	2
20"	6130300001	CCW	30°	Interchangeable	2
20"	60561101	CW	33°	Interchangeable	2
20"	60561201	CCW	33°	Interchangeable	2
22"	60561301	CW	27°	Interchangeable	2
22"	60561401	CCW	27°	Interchangeable	2
22"	60561501	CW	33°	Interchangeable	2
22"	60561601	CCW	33°	Interchangeable	2
24"	60561701	CW	27°	Interchangeable	2
24"	60561801	CCW	27°	Interchangeable	2
24"	60561901	CW	33°	Interchangeable	2
24"	60562001	CCW	33°	Interchangeable	2
26"	60761301	CW	27°	Interchangeable	1
26"	60761401	CCW	27°	Interchangeable	1
26"	6130330001	CW	29°	Interchangeable	1
26"	6130320001	CCW	29°	Interchangeable	1
26"	6130740001	CW	29°	DISCHARGE / .625 BORE	1
26"	60761501	CW	33°	Interchangeable	1
26"	60761601	CCW	33°	Interchangeable	1
28"	6130350001	CW	27°	Interchangeable	1
28"	6130340001	CCW	27°	Interchangeable	1
28"	6130370001	CW	29°	Interchangeable	1
28"	6130360001	CCW	29°	Interchangeable	1
28"	6130390001	CW	33°	Interchangeable	1
28"	6130380001	CCW	33°	Interchangeable	1
30"	6130410001	CW	27°	Interchangeable	1
30"	6130400001	CCW	27°	Interchangeable	1
30"	6130430001	CW	29°	Interchangeable	1
30"	6130420001	CCW	29°	Interchangeable	1
30"	6130450001	CW	33°	Interchangeable	1
30"	6130440001	CCW	33°	Interchangeable	1

Specifications are subject to change without notice or obligation

Applications: Industrial Air Circulators, Exhaust Fan & Large Condensing Units and Agricultural Ventilation

For performance information please refer to Appendix A

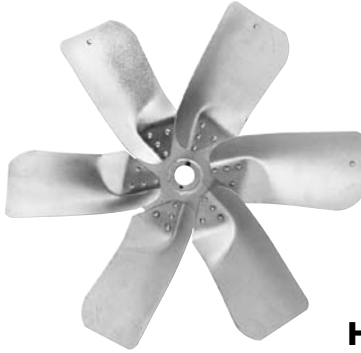

- **High quality, heavy duty mill galvanized steel blades with corrosion-resistant center spiders**

HEAVY DUTY – CLOCKWISE ROTATION

Diameter (inches)	Part Number	Pitch	Blade Depth	Blade Width	Max. RPM	Blade Wt. (lbs.)
30"	60833801	40°	5"	7 ⁹ / ₁₆ "	1140	18.00
36"	60833901+	40°	5"	8 ¹ / ₄ "	860	21.00
42"	60834001+	40°	5 ¹ / ₄ "	9 ³ / ₄ "	650	32.00
48"	60834101+	40°	5 ¹ / ₂ "	11 ⁵ / ₈ "	500	37.00
54"	60834201+	40°	6 ¹ / ₄ "	11 ⁹ / ₁₆ "	555	57.00

* Blade width is measured at the widest points of the blade.

+ Must be shipped via common carrier.

EXTRA HEAVY DUTY – CLOCKWISE ROTATION

Diameter (inches)	Part Number	Pitch	Blade Depth	Blade Width	Max. RPM	Blade Wt. (lbs.)
30"	6126890010+	40°	5"	7 ⁹ / ₁₆ "	1220	21.00
36"	6126890011+	40°	5"	8 ¹ / ₄ "	940	27.00
42"	6126890012+	40°	5 ¹ / ₄ "	9 ³ / ₄ "	860	40.00
48"	6126890013+	40°	5 ¹ / ₂ "	11 ⁵ / ₈ "	675	46.00
54"	6126890014+	40°	6 ¹ / ₄ "	11 ⁹ / ₁₆ "	610	77.00

* Blade width is measured at the widest points of the blade.

+ Must be shipped via common carrier.

SPLIT TAPERED BUSHINGS FOR DESIRED BORE SIZE

- **For 1/2" through 1⁷/₁₆" bore range**
- **Steel construction**

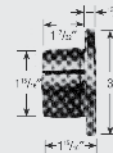
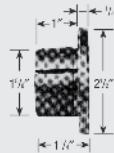

H-STYLE

(FOR 24"-48" PROPELLERS)

Part No.	Bore
60331504	1/2"
60331505	5/8"
60331506	3/4"
60331507	7/8"
60331508	1"
60331501	1 1/8"
60331502	1 3/16"
60331509	1 1/4"
60331503	1 3/8"

P-STYLE

(FOR 54"-60" PROPELLERS)

Part No.	Bore
72513808	1"
72513809	1 1/8"
72513810	1 1/4"
72513811	1 3/8"
72513812	1 3/16"
72513813	1 5/8"
72513815	1 7/16"

Standard Keyway Sizes

Diameter of Shaft	Keyseat Width X Depth
5/16 - 7/16	3/32 X 3/64
1/2 - 9/16	1/8 X 1/16
5/8 - 7/8	3/16 X 3/32
15/16 - 1 1/4	1/4 X 1/8
1 5/16 - 1 3/8	5/16 X 5/32
1 7/16 - 1 1/4	3/8 X 3/16
1 13/16 - 2 1/4	1/2 X 1/4

Measurements in inches.

Split Tapered Bushings must be ordered separately

Specifications are subject to change without notice or obligation

AGRICULTURAL PROPELLERS

3-Blade - Stainless Steel & Aluminum



Applications: Greenhouse Nurseries, Tobacco & Poultry Farms, Warehouse, Agricultural Ventilation

For performance information please refer to Appendix A

STAINLESS STEEL



- 3-blade stainless steel construction
- CW rotation
- Electroplated spider
- Keyway
- Use for Corrosive Air Exhaust Applications



3-BLADE STAINLESS STEEL AGRICULTURAL PROPELLERS

Diameter (inches)	Part Number	Application	Bore Size	HP	CFM	Nominal RPM	Max. RPM
36"	6132510001	Direct Drive	5/8" kW	1/2	9600	850	900
48"	6132530001	Belt Drive	1" kW	1	21800	550	708

ALUMINUM

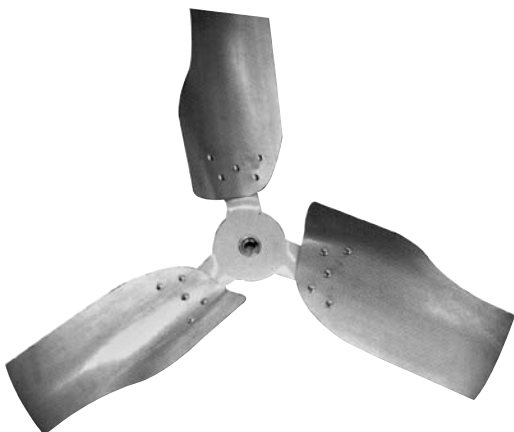

- 3-blade aluminum construction
- CW rotation
- Electroplated spider
- Keyway

3-BLADE ALUMINUM AGRICULTURAL PROPELLERS

Diameter (inches)	Part Number	Application	Bore Size	HP	CFM	Nominal RPM	Max. RPM
36"	6132520001	Direct Drive	5/8" kW	1/2	9600	850	900
48"	6132540001	Belt Drive	1" kW	1	21800	550	708

Specifications are subject to change without notice or obligation

THE FUTURE OF AIR MOVING!
**Applications: Condensing Units Desiring
Low Noise and High Efficiency**
For performance information please refer to Appendix A

- **The Cobra Blade can be used to replace a square condenser propeller to make the unit 10X quieter**
- **Cobra Blades are made of high strength aluminum**
- **Cobra Blades to Standard Blades Cross Reference on page 236**

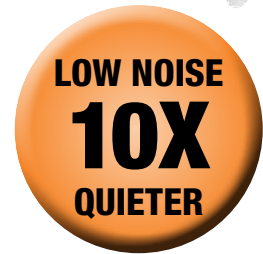
2-BLADE

Diameter (inches)	Part Number	Rotation	Pitch	Quantity Pack
22"	6140560001	CW	20°	1
22"	6140600001	CW	24°	1
22"	6140650001	CW	28°	1
22"	6140710001	CW	34°	1
24"	6139700001	CCW	20°	1
24"	6139820001	CCW	24°	1
24"	6139900001	CCW	28°	1
24"	6140020001	CCW	34°	1
26"	6140160001	CCW	20°	1
26"	6140220001	CCW	24°	1
26"	6140300001	CCW	28°	1
26"	6140440001	CCW	34°	1
28"	6139520001	CCW	20°	1
28"	6139550001	CCW	24°	1
28"	6139580001	CCW	28°	1
28"	6139610001	CCW	34°	1

Hub location is Interchangeable.
Cobra Blades to Standard Blades Cross Reference (Page 236)

**Applications: Condensing Units
Desiring Low Noise and High Efficiency**

THE FUTURE OF AIR MOVING!

For performance information please refer to Appendix A

3-BLADE

Diameter (inches)	Part Number	Rotation	Pitch	Quantity Pack
22"	6140570001	CW	20°	1
22"	6140610001	CW	24°	1
22"	6140660001	CW	28°	1
22"	6140720001	CW	34°	1
24"	6139720001	CCW	20°	1
24"	6139840001	CCW	24°	1
24"	6139920001	CCW	28°	1
24"	6140040001	CCW	34°	1
26"	6140190001	CW	20°	1
26"	6140250001	CW	24°	1
26"	6140330001	CW	28°	1
26"	6140470001	CW	34°	1
28"	6139530001	CCW	20°	1
28"	6139560001	CW	24°	1
28"	6139590001	CCW	28°	1
28"	6139620001	CCW	34°	1

Hub location is Interchangeable.
Cobra Blades to Standard Blades Cross Reference (Page 236)

4-BLADE

Diameter (inches)	Part Number	Rotation	Pitch	Quantity Pack
22"	6140580001	CW	20°	1
22"	6140620001	CW	24°	1
22"	6140670001	CW	28°	1
22"	6140730001	CW	34°	1
24"	6139740001	CCW	20°	1
24"	6139860001	CCW	24°	1
24"	6139940001	CCW	28°	1
24"	6140060001	CCW	34°	1
26"	6140200001	CCW	20°	1
26"	6140260001	CCW	24°	1
26"	6140340001	CCW	28°	1
26"	6140480001	CCW	34°	1
28"	6139540001	CCW	20°	1
28"	6139570001	CCW	24°	1
28"	6139600001	CCW	28°	1
28"	6139630001	CCW	34°	1

Hub Location is Interchangeable
Cobra Blades to Standard Blades Cross Reference (Page 236)

Specifications are subject to change without notice or obligation

Replacement Propellers For Most Companies

For performance information please refer to Appendix A

- Use the chart below to find the equipment and the OEM part number, then order with the Lau part number to receive an exact replacement to the OEM propeller.
- All propellers have a 1/2" hub and are made of either galvanized steel or aluminum blades where indicated.

NORDYNE, FRIGIDAIRE, WESTINGHOUSE, TAPPAN, KELVINATOR, PHILCO

OEM Part Number	Lau Part Number	No. of Blades	Dia. (inches)	Pitch	Rot.	Hub Location	Blade Material
667212-D	6128140001	3	24"	30°	CW	Intake	Steel
667261-C	6128150001	3	18"	18°	CW	Intake	Steel
667262-B	6128120001	3	18"	28°	CW	Intake	Steel
667303-B	6128130001	3	24"	23°	CW	Intake	Steel
667316-A	6132190001	3	24"	20°	CW	Intake	Steel

RHEEM, RUDD

OEM Part Number	Lau Part Number	No. of Blades	Dia. (inches)	Pitch	Rot.	Hub Location	Blade Material
70-100580-03	6128190001	3	24"	22°	CCW	Intake	Steel
70-100580-04	6128170001	3	24"	28°	CCW	Intake	Steel
70-100580-07	6128180001	2	22"	28°	CCW	Intake	Steel

YORK, LUXAIRE, COLEMAN

OEM Part Number	Lau Part Number	No. of Blades	Dia. (inches)	Pitch	Rot.	Hub Location	Blade Material
026-17688	6128210001	3	22"	36°	CW	Intake	Steel
026-17690	6128240001	2	22"	20°	CW	Intake	Aluminum
026-17698	6128200001	3	22"	30°	CW	Intake	Aluminum
026-17785	6128220001	3	17 ¹¹ / ₁₆ "	22°	CW	Intake	Aluminum
026-128812	6128230001	3	24"	30°	CW	Intake	Steel

LENNOX

OEM Part Number	Lau Part Number	No. of Blades	Dia. (inches)	Pitch	Rot.	Hub Location	Blade Material
68J2601	6128270001	3	18"	26°	CCW	Intake	Aluminum
36G8001	6128280001	3	24"	21°	CW	Discharge	Aluminum
68J2701	6128260001	4	18"	24°	CCW	Intake	Aluminum
68J2801	6128250001	4	18"	34°	CCW	Intake	Aluminum

GOODMAN

OEM Part Number	Lau Part Number	No. of Blades	Dia. (inches)	Pitch	Rot.	Hub Location	Blade Material
B10867-56	6128300001	3	18"	29°	CCW	Intake	Steel
B10867-50	6128290001	3	22"	24°	CCW	Intake	Steel
B10867-48	6128310001	3	22"	30°	CCW	Intake	Steel

Specifications are subject to change without notice or obligation

FIXED HUB STYLE PROPELLER

Aluminum Fixed Hub



Applications: Fan Coils, Heaters, Small Appliances, Freezers and Refrigerators

For performance information please refer to Appendix Aâ

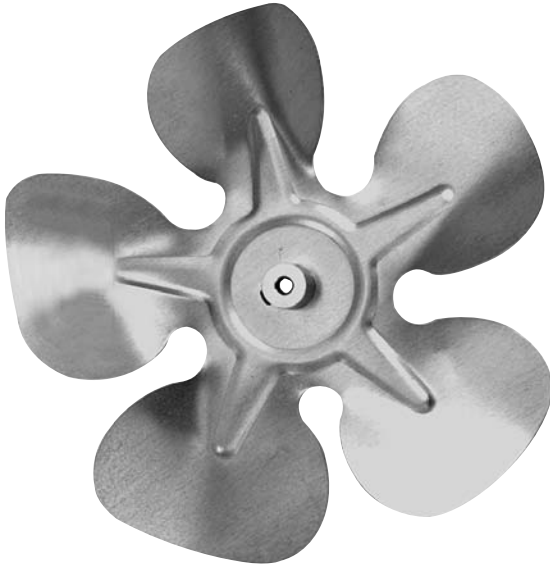

- **Durable one piece design**
- **Comes with either a 1/4" or 5/16" bore**
- **High quality aluminum in both CW and CCW rotations**
- **5 and 6-blades**



Hubless Style aluminum propellers are shown on Page 29.

FIXED HUB STYLE

Dia. (in.)	Part No.	No. of Blades	Rotation	Pitch	Depth	RPM	Bore Size	Std. Wt. (lbs.)	Max/Std Pack
7"	60834801	5	CW	27°	1½"	3600	1/4"	1	4
7"	60834901	5	CCW	27°	1½"	3600	1/4"	1	4
7"	60835001	5	CW	27°	1½"	3600	5/16"	1	4
7"	60835101	5	CCW	27°	1½"	3600	5/16"	1	4
8"	60835201	5	CW	24°	1⅙"	3600	1/4"	1¼	4
8"	60835301	5	CCW	24°	1⅙"	3600	1/4"	1¼	4
8"	60835401	5	CW	30°	1⅝"	3600	1/4"	1¼	4
8"	60835501	5	CCW	30°	1⅝"	3600	1/4"	1¼	4
8"	60835601	5	CW	18°	1⅙"	3600	5/16"	1¼	4
8"	60835701	5	CCW	18°	1⅙"	3600	5/16"	1¼	4
8"	60835801	5	CW	23°	1⅝"	3600	5/16"	1¼	4
8"	60835901	5	CCW	23°	1⅝"	3600	5/16"	1¼	4
9"	60836201	5	CW	26°	1¼"	3000	5/16"	1⅞	4
9"	60836301	5	CCW	26°	1¼"	3000	5/16"	1⅞	4
10"	60836601	5	CW	31°	1⅝"	2400	1/4"	2	4
10"	60836701	5	CCW	31°	1⅝"	2400	1/4"	2	4
10"	60836801	5	CW	20°	1⅝"	2400	5/16"	2	4
10"	60836901	5	CCW	20°	1⅝"	2400	5/16"	2	4
10"	60837001	5	CW	31°	1⅝"	2400	5/16"	2	4
10"	60837101	5	CCW	31°	1⅝"	2400	5/16"	2	4

Specifications are subject to change without notice or obligation

Applications: Fan Coils, Heaters, Small Appliances, Freezers and Refrigerators

For performance information please refer to Appendix A

- **Durable one piece design**
- **High quality aluminum**
- **Hub on intake side**
- **3 or 5-blades**

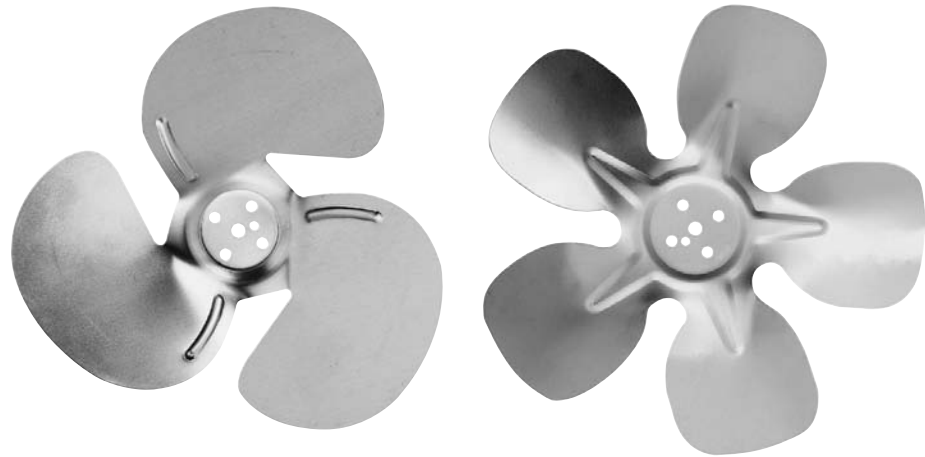

HUBLESS STYLE

Dia. (inches)	Part Number	No. of Blades	Rotation	Pitch	Depth	RPM	Quantity Pack
8 ³ / ₄ "	60838301	3	CW	32°	3"	1550	4
7"	60837201	5	CW	20°	1"	3600	4
7"	60837301	5	CW	31°	1 ¹ / ₂ "	3600	4
7 ³ / ₄ "	60837401	5	CW	20°	1 ¹ / ₈ "	3600	4
7 ³ / ₄ "	60837501	5	CW	31°	1 ¹¹ / ₁₆ "	3600	4
8"	60837601	5	CW	24°	1"	3600	4
8"	60837701	5	CW	31°	1 ⁵ / ₈ "	3600	4
9"	60837801	5	CW	20°	1"	3000	4
9"	60837901	5	CW	31°	1 ⁵ / ₈ "	3000	4
10"	60838001	5	CW	20°	1"	2400	4
10"	60838101	5	CW	31°	1 ⁵ / ₈ "	2400	4

INTERCHANGEABLE HUBS FOR HUBLESS PROPELLERS

(Order Separately)

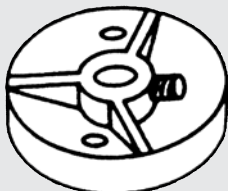

Part Number	Bore
05382501	1/4"
05382502	5/16"

Includes set and mounting screws

DID YOU KNOW?

You can replace a 3-blade fan with a 5-blade fan?

Choose a replacement that matches the CFM required. Ensure the brake HP required does not exceed the nameplate rating of the motor.

For directions, see Page 33.

PROPELLER ACCESSORIES



SPLIT TAPERED BUSHINGS FOR DESIRED BORE SIZE

- For 1/2" through 1 7/16" bore range
- Steel construction

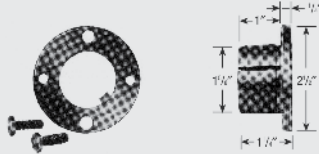

H-STYLE
(FOR 24"-48" PROPELLERS)

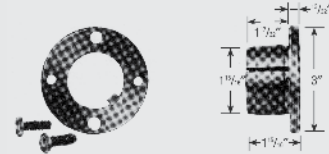

P-STYLE
(FOR 54"-60" PROPELLERS)

Standard Keyway Sizes

Diameter of Shaft	Keyseat Width X Depth
5/16 - 7/16	3/32 X 3/64
1/2 - 9/16	1/8 X 1/16
5/8 - 7/8	3/16 X 3/32
15/16 - 1 1/4	1/4 X 1/8
1 1/16 - 1 3/8	5/16 X 5/32
1 7/16 - 1 1/4	3/8 X 3/16
1 13/16 - 2 1/4	1/2 X 1/4

Measurements in inches.

Part No.	Bore
60331504	1/2"
60331505	5/8"
60331506	3/4"
60331507	7/8"
60331508	1"
60331501	1 1/8"
60331502	1 3/16"
60331509	1 1/4"
60331503	1 3/8"

Part No.	Bore
72513808	1"
72513809	1 1/8"
72513810	1 1/4"
72513811	1 3/8"
72513812	1 3/16"
72513813	1 5/8"
72513815	1 7/16"

Split Tapered Bushings must be ordered separately

INTERCHANGEABLE HUBS FOR 3, 4 & 5-BLADE PROPELLERS

(Order Separately)

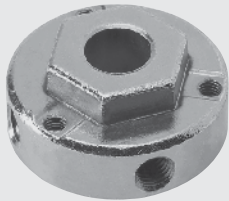

Includes set and mounting screws

Part Number	Bore	Set Screw
60765801	1/4"	1
60765802	5/16"	1
60765803	3/8"	1
60765804	1/2"	2
60765805	5/8"	2
60765806	3/4"	2

- All steel with extra metal for durability in the two mounting surfaces (hex & round)
- One inventory for all propellers – hex on one side, round on the other (use either)
- 5/8" and 3/4" models have keyway with extended body length for increased strength
- Double locking device grips threads without backing out
- Order in boxes of 12 or individually

INTERCHANGEABLE HUBS FOR HUBLESS PROPELLERS

(Order Separately)

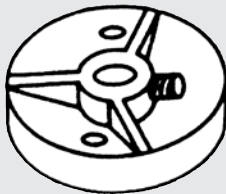

Includes set and mounting screws

Part Number	Bore
05382501	1/4"
05382502	5/16"

Lau HEX design transfers the torque from the screws to the hub and spider.

- SPIDER
- HUB MOUNTING FLANGE

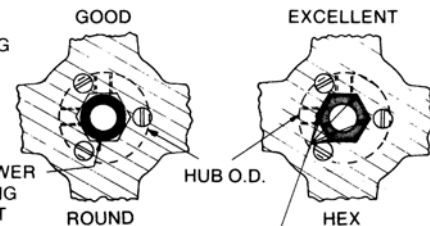

NO HOLDING POWER AT HUB MOUNTING FLANGE, ONLY AT MOUNTING SCREWS.

HOLDING POWER AT EACH HEX POINT AND MOUNTING SCREWS

Specifications are subject to change without notice or obligation

For Contractors, Service Technicians and Maintenance Professionals

HUB PULLERS



HEAVY DUTY APPLICATIONS

Part No. 05214101

- Zinc plated, heavy steel construction.
- Sight holes for visual alignment of puller and motor shaft.
- Four square head cup point grab bolts.
- 5/8" bolt will not bend with proper use.
- Bar top ... grip with wrench.
- 1/4" steel collar.
- 1" long threaded surface.
- Torque Limit: 75 ft. lbs.



GENERAL DUTY APPLICATIONS

Part No. 05380401

- Precision machined.
- 5/8" steel bolt machined and tapered on one end.
- 1 1/4" threading into body resists stripping.
- Standard 7/8" wrench fitting.
- Four grab bolts for maximum holding power.
- Torque Limit: 75 ft. lbs.

Fan blades can be removed in two different ways. If the fan blade has a protruding hub, use the option shown below.



Place the narrow end of the plastic centering sleeve over the end of the motor shaft.



Place the head or face of the puller against the front of the fan blade hub, and insert the puller shaft into the wide end of the centering sleeve. **This is critical.** It will align the puller with the motor shaft. Otherwise, the puller will just pull against itself.



Get the four fingers. Take each finger and place one hooked end of the finger around the backside of the fan blade hub. Hook the other end of the finger into one of the four finger holes on the puller body. (Finger holes are the 1/2" holes located 1/3 of the way up the puller body.) In effect, the fingers reach around and grab the back of the fan blade hub from the puller.



Now use a wrench to turn the puller shaft. (To prevent the puller from twisting, it is suggested you grasp the bar across the top of the puller with a second wrench.) The motor shaft will then be pushed through and away from the fan blade and the fan blade will be pulled off the shaft.

Optional Method (this method is also used for Blower Wheels).



Place the narrow end of the plastic centering sleeve over the end of the blower motor shaft.



Place the head of the puller over the blower wheel hub, and insert the puller shaft into the wide end of the centering sleeve. **This is critical.** It will align the puller with the blower motor shaft. Otherwise, the puller will just pull against itself.



Firmly tighten the four grasping bolts so they grab onto the blower wheel hub.



Now use a wrench to turn the puller shaft. (To prevent the puller from twisting, it is suggested you grasp the bar across the top of the puller with a second wrench.) The motor shaft will then be pushed through and away from the fan blade and the fan blade will be pulled off the shaft.

REPLACEMENT PARTS FOR HUB PULLERS

Hub Puller
05380401 General Duty
05214101 Heavy Duty

Replacement Fingers (4/set)
05249901
05221101

Main Center Shaft
05249701
05221201

Centering Sleeve
05249801
05221301

Specifications are subject to change without notice or obligation

PROPELLER ACCESSORIES

Service Tools



RAINSHIELDS

An inexpensive way to protect your motor



3 1/2"

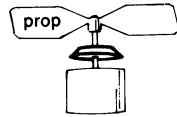

Position Rainshield between propeller and motor. Use 3 1/2" diameter for closed motors.



7"

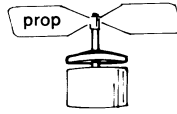

Interior cooling blades force air over motor. Use 7" diameter for open type motors.

- Prevents rain from getting into the motor bearings on vertical shaft motor applications
- Used as original equipment on most new air conditioners
- Press-on fit for 1/2" to 5/8" shafts
- 7" with interior cooling blades reduces motor winding temperature to protect open motors
- 3 1/2" for closed motors protects bearings

Part Number	Single Size
60385303	3 1/2" x 1/2"
60379501	7" x 1/2"
60379502	7" x 5/8"

PITCH GAUGE

Measures the correct pitch & rotation direction



FOLLOW THESE 3 STEPS TO MEASURE PROPELLER ROTATION AND PITCH:

- STEP 1**
Position the faceplate of the gauge on the blade of the fan.
- STEP 2**
Place the foot of the wire body of the Pitch Gauge on the spider (center section) of the fan.
- STEP 3**
The pointer gives a direct reading of the pitch in degrees, and the clockwise/counter-clockwise markings indicate the rotation.



Part Number
05099801

ALLEN HEAD SCREWS



Designed for Universal Hubs

Part Number	Recommended Seating Desc.	Torque	Quantity Pack
05055001	1/4-28 x 1/2"	70 in-lbs.	12
05055002	5/16-24 x 5/8"	130 in-lbs.	12

Specifications are subject to change without notice or obligation

Replacing a 3-Blade Prop with a 4 or 5-Blade Prop

DID YOU KNOW?

You can replace a propeller with a propeller that has a different number of blades. For example, if you have a condenser that has a 3-blade fan, you can replace it with a 4 or 5-blade propeller.

How to replace a 3-Blade Propeller with a 4-Blade or 5-Blade Propeller.

Step 1: Find the closest match to current blade from the data in the catalog.

Match number of blades of the original propeller you are replacing.

Match diameter of the original blade you are replacing.

Match pitch (as closely as possible) to the original blade you are replacing.

Check direction of rotation.

Step 2: Check current motor RPM for the existing blade.

Step 3: Check the Lau catalog technical data for the closest matching 3-blade replacement propeller's CFM and HP required.

Step 4: Find a propeller with same diameter and a different number of blades.

Step 5: Following the row for the motor's speed, find a propeller with CFM closest to original blade. Make sure the CFM is equal or greater to CFM of the blade you are replacing.

Do NOT replace existing blade with a propeller that has a lower CFM.

Step 6: Ensure new blade's BHP required is less than the nameplate rating of the motor. If BHP exceeds name plate rating, use prop with less CFM until BHP is under nameplate rating on motor.



If minimum HP required for a fan blade is .501 the motor must be more than 1/2 HP motor.

EXAMPLE:

Original propeller is a 3-blade, 24", 27°, clockwise direction. Check Lau catalog to find a 24", 27° pitch propeller. Part number 60557701 matches this propeller. Motor RPM is 1075 and the CFM is 5,195 with a required BHP of .59 (at .3"WC). 60557701 is not in stock so turn to the 4-blade section. Find the 24" blades. The 24", 27° pitch in the 4 blade section (part 60559701) in the 1075 RPM row has a CFM of 5,546 with a required HP of .657. The CFM is greater than 3-blade replacement (and original blade). If the motor nameplate rating is greater than .657 (such as .75), the 4 blade propeller can replace the 3 blade propeller.

FREQUENTLY ASKED QUESTIONS

What is the effect on the head pressure if the new propeller increases CFM?

Although the head pressure will increase as CFM increases, the difference should be small enough to not adversely affect performance of the unit if the new blade is a close match to the original blade.

Does a heavier blade require more HP from the motor?

No, the weight of the blade does not affect how much HP is required to turn it and will not hurt the efficiency of your blade. However, the stronger the blade the longer it will last.

Will an increase in BHP required hurt my unit's efficiency?

It may affect your unit's efficiency which is why it is important to find the closest match to your current blade. You may find the new blade requires less BHP and improves your unit's efficiency.

WHY INSTALL A NEW BLOWER ASSEMBLY

Lau Universal Replacement Blowers are the cost-effective alternative to time-consuming blower repairs. Lau blower products are exclusively engineered to endure the most rugged handling and withstand the increased workload expected of quality replacement products through years of service.

For over 80 years, Lau has been the recognized global leader in air moving equipment for heating, ventilation, and air conditioning industry. Lau offers several categories of blowers in popular sizes for all your property maintenance needs.

PREVENTATIVE MAINTENANCE FOR BELT DRIVE BLOWERS

Show the homeowner how they can perform basic service on the blower:

- Oil the motor seasonally with medium weight (SAE 20) motor oil.
- Vacuum the blower and blower compartment seasonally.
- If the blower has oil-type bearings, they must be oiled regularly. See detailed oiling information on the blower housing.
- Change filters seasonally and replace when dirty.
- The cabinet door should be kept closed except when performing service.

BELT DRIVE TIP

Loosen the setscrew on the outer face of the variable pitch motor pulley and turn the face.

The speed is **reduced** by turning the outer face to move the two pulley faces farther apart.

The speed is **increased** by turning the outer face to move the faces closer together.



For options on pulleys and belts, check out the Gates section beginning on Page 61.



BLOWER TABLE OF CONTENTS

Blower Assemblies

How to Replace a Blower	35
Belt Drive Blowers	36-37
Blower Selection Procedure	37
Twin Blower Parts Kit	37
Vibro-Pads	37
Direct Drive Blowers	38
Blower Performance Data	39

Blower Wheels

Single Inlet, Galvanized	40-43
Steel Shaft Adapter Bushings	43
FGP & BD Series, Single Inlet, Galvanized	44
Double Inlet, Aluminum with Steel Hubs	45
Double Inlet, Direct Drive	46-47
Double Inlet, Belt Drive	48-49
Reducing Bushings	49
Double Inlet, Large Belt Drive	50-51

FGP Series Blower Assemblies	52
Discharge Positions	52

Blower Parts & Accessories

Blower Replacement Parts	53-54
Component Limits	54
Brackets & Bracket Kits	55
Bearings	56-58
How to Install a Self-Locking Collar on Sealed & Pillow Block Bearings	58
Installation Parts	
Kits & Motor Adjustment Grommets	59
Vibro-Pads & Shafts	59

Torque Guide Chart for Lau Blower Wheels ..	60
--	----

HOW TO REPLACE A BELT DRIVE BLOWER



CAUTION: Always disconnect, lock and tag power supply before servicing the blower or working with the unit for any reason. This is especially important with blowers equipped that have automatic reset thermal protection. Motor may activate without warning.

1. Begin by mounting the blower feet. Feet can be mounted in any of four standard positions by using the slotted holes and screw holes in the housing sides. Any variation of position may be easily obtained by trimming off the tabs and drilling new screw holes. The hardware bag contains rubber Vibro-Pads. Slip one into each of the corner holes of the feet.
2. Attach motor mounting bracket to the blower housing using the provided sheet metal screws. Attach the motor on the mount, but don't tighten the bolts until after installing and aligning the belts and pulleys. Bolt the tension-adjusting bracket to the motor, start the adjusting screw, add the locknut, and place the rubber bumper on the end.
3. Mount the variable-pitch motor pulley on the motor shaft with its movable face towards the end of the shaft, away from the motor. On the side of the pulley nearest the motor, tighten the setscrew on the *flat* or *key* of the motor shaft. Leave some clearance between the pulley and the end bell of the motor.
4. Mount the blower pulley on the blower shaft by tightening its setscrew securely on the *flat* or *key* of the shaft. Be sure the blower pulley is perpendicular to the shaft; it will be used later as a guide for aligning the drive.
5. Wipe off the pulleys and belt with a clean rag to get rid of oil and dirt. Dirt and grease are tough abrasives that cause the belt to wear out faster, throwing it out of balance and shortening its life.
6. Install the V-Belt in the pulley grooves by loosening the belt take-up or the adjusting screw on the motor. Do not *roll* or *snap* the belt on the pulleys; this causes too much strain on the pulleys. Be sure the belt doesn't *bottom* in the pulley grooves.
7. Align both pulley and shafts by moving the motor on its motor mount. Hold a straight edge flush against the blower pulley, then move the motor until the belt is parallel to the straight edge.
8. A pulley alignment short-cut: Sight down the top of the belt from slightly above it. If the belt is straight where it leaves the pulley and does not bend, the alignment is fairly accurate.
9. Check belt tension before proceeding further. Remember that a V-belt *rides* the inside of the pulley faces.



Belt-Tension Adjustment Tip: Using the belt take-up or motor-adjusting screw, tighten the belt until the slack side can be depressed about 3/4" for each foot of span between the pulleys. Otherwise, use a Gates tension tester on Page 87.



Warning: Excessive belt tension is the most frequent cause of bearing wear and noise.

10. Install the blower in the furnace or air conditioning unit following the checklist below:
 - Center and seal the blower outlet in the blower opening so there is no air leakage.
 - Support the blower by its mounting feet, avoid metal-to-metal contact.
 - Wire the motor according to the diagram supplied with the unit or its control, following all local codes.
 - Anchor the wiring with resilient clips to keep it from rattling or transmitting vibration noises.
11. Double check all electrical connections. Insure all fasteners are tight. Remove all loose tools and objects from the furnace or air conditioning compartment, blower wheel, and belt. Install cabinet door. Turn electrical power on and run for five to ten minutes.
12. Turn power off and adjust blower speed as required. The blower speed can be adjusted to increase or decrease its output of air in a furnace or air conditioning unit. With the cabinet door closed, check motor amps with an amp probe. Insure amp reading is within the motor nameplate rating.

BLOWER ASSEMBLIES

Belt Drive Blowers



Applications: Residential & Light Commercial

For performance information please refer to Appendix B

COMPLETE BLOWER ASSEMBLIES CONSIST OF:

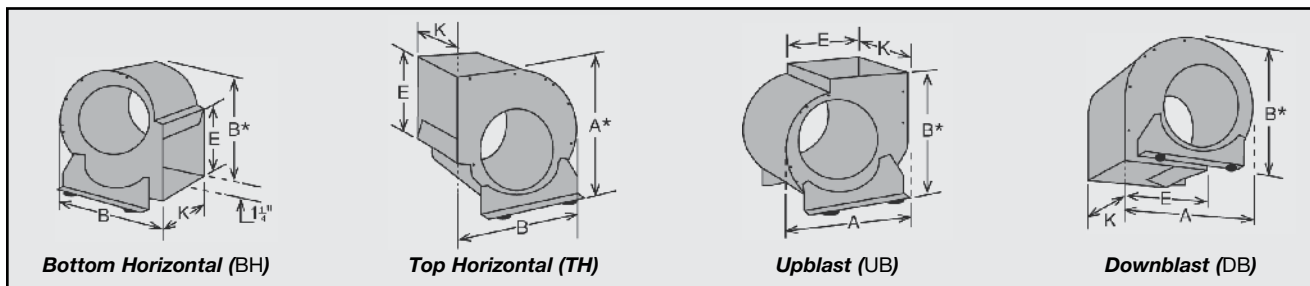
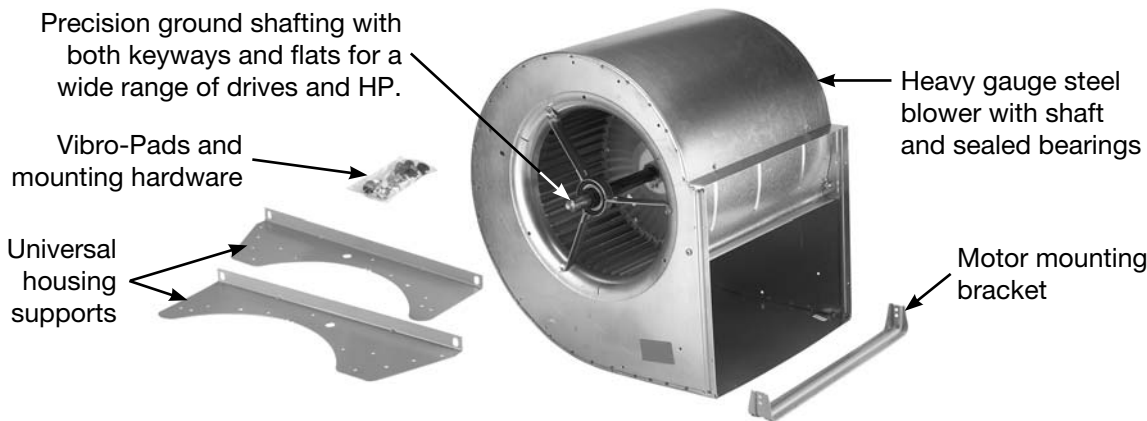

Purchase belts, motor and blower pulleys separately.

BELT DRIVE BLOWERS

Part Number	Model Number	K	E	A	B	Shaft Size
0574300001M	A9-6ACE	8 ¹ / ₄ "	10 ¹ / ₄ "	15 ⁷ / ₁₆ "	14 ¹⁵ / ₁₆ "	3/4"
0574300002M	A9-7ACE	9 ³ / ₁₆ "	10 ¹ / ₄ "	15 ⁷ / ₁₆ "	14 ¹⁵ / ₁₆ "	3/4"
0574300003M	A9-9ACE	11 ⁷ / ₈ "	10 ¹ / ₄ "	15 ⁷ / ₁₆ "	14 ¹⁵ / ₁₆ "	3/4"
0574310001M	A10-6ACE	8 ¹ / ₄ "	11 ³ / ₈ "	17 ¹ / ₄ "	16 ¹ / ₂ "	3/4"
0574310002M	A10-8ACE	10 ¹ / ₂ "	11 ³ / ₈ "	17 ¹ / ₄ "	16 ¹ / ₂ "	3/4"
0574310003M	A10-10ACE	13 ¹ / ₁₆ "	11 ³ / ₈ "	17 ¹ / ₄ "	16 ¹ / ₂ "	3/4"
3824340021M	A12-6ACE	8 ¹³ / ₁₆ "	13 ⁷ / ₁₆ "	20 ⁷ / ₁₆ "	19 ⁵ / ₁₆ "	1"
3824340022M	A12-9ACE	12 ³ / ₈ "	13 ⁷ / ₁₆ "	20 ⁷ / ₁₆ "	19 ⁵ / ₁₆ "	1"
38243420M	A12-12ACE	15 ³ / ₄ "	13 ⁷ / ₁₆ "	20 ⁷ / ₁₆ "	19 ⁵ / ₁₆ "	1"
3820800003M	A15-9ACE	12 ¹³ / ₁₆ "	15 ⁷ / ₈ "	24 ¹ / ₈ "	22 ⁵ / ₈ "	1"
3820800004M	A15-11ACE	14 ¹¹ / ₁₆ "	15 ⁷ / ₈ "	24 ¹ / ₈ "	22 ⁵ / ₈ "	1"
38208002M	A15-15ACE	18 ⁵ / ₈ "	15 ⁷ / ₈ "	24 ¹ / ₈ "	22 ⁵ / ₈ "	1"
3824300003M	A18-13ACE	17 ³ / ₈ "	18 ⁷ / ₈ "	29 ³ / ₁₆ "	27"	1"
38243002M	A18-18ACE	21 ⁷ / ₈ "	18 ⁷ / ₈ "	29 ³ / ₁₆ "	27"	1"

Maximum blower operating temperature, 150°F. **Caution:** Most motors have maximum 104°F operating temperature. Must ship via common carrier.

Specifications are subject to change without notice or obligation

Blower Selection Procedure	Example	Remarks
1. Determine blower position from diagrams on Page 36.	For our example, we'll say it is UPBLAST.	UB
2. Determine the overall dimensions for fit (see dimensions A and B).	Measure old blower.	A = 18" B = 16"
3. Determine the blower outlet dimensions (see dimensions K and E).	Measure old blower.	E = 11 ³ / ₈ " K = 13 ¹ / ₄ "
4. Compare the above with the Blower Dimension Chart and select the nearest fit (K and E are critical).	Model Number Part Number	A10-10ACE 38-2076-01
5. Refer to the Blower Performance Chart (Appendix B) with the model number chosen. Select the CFM* desired, the wheel RPM, and HP under the static pressure. (+ If static pressure is unknown, use the 1" SP column.)	At 1,000 CFM and 3/4" static pressure, the wheel RPM is 843 at .30 BHP.	CFM = 1000 RPM = 843 BHP = .30
6. Refer to the Drive Chart for Belt Drive Blower Assemblies (Appendix B) to determine pulley and belt sizes required, as well as the motor mount location for same. Since the BHP is .30, the motor requirement is a minimum 1/3 HP nameplate rating. Remember , "over-motoring" or "under-motoring" will cause excessive heat for any motor.	A 10" blower with an upblast (UB) position requires motor position #2, a 3 ¹ / ₄ " motor pulley, 6" wheel pulley and a 41" belt based on 843 RPM (assumes a 48" frame motor).	Position #2 Motor Pulley = 3 ¹ / ₄ " Wheel Pulley = 6" Belt = 41" Motor: 1/3 HP
<p>NOTES:</p> <ul style="list-style-type: none"> Standard sleeve bearings are suitable for up to 3/4 HP on 9" and 10" blowers and up to 1 HP on 12" to 18" designs. Above these limits, ball bearings are required. 		
<p> Before making final selections, review Component Limits shown on Page 54.</p> <p>Standard sleeve bearings on Belt Drive Blowers can be replaced in the field using the sealed-type ball bearings on Page 56-57.</p>		

- **Converts two standard replacement blowers to a twin assembly**
- **Includes ball bearings, spreader bars, shaft, hardware and instruction manual**



For Twin Blower performance, use same Single Blower Performance Data but double CFM and BHP (brake horsepower) at same SP (static pressure).

* For Blowers other than full width, redrill holes in spreader bars to match overall blower width desired. Also, cut shaft to length required. For Twin Blower assemblies larger than 15" diameter, order a complete twin assembly from the factory (allow 8 to 10 weeks lead-time).

TWIN BLOWER PARTS KIT

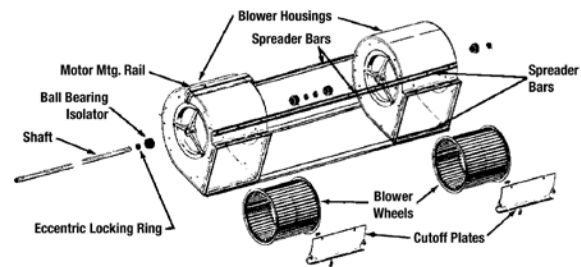

Part Number	Description	Bore Size	Shaft Length	Spreader Bar Length
02484093	2A9-6A*, 2A9-7A, 2A9-9A	3/4"	36 ¹ / ₈ "	32 ¹ / ₂ "
02484094	2A10-6A*, 2A10-8A*, 2A10-10A	3/4"	39 ³ / ₄ "	36"
02484095	2A12-6A*, 2A12-9A*, 2A12-12A	1"	47 ³ / ₈ "	43"
02484096	2A15-9A*, 2A15-11A*, 2A15-15A	1"	56 ¹ / ₄ "	52"

- **Reduces vibration, wear and noise on blowers, fans and motors**
- **Resilient rubber pads snap easily into place**
- **Packaged 12 per bag (order by part number)**

Part Number Per Doz.

38220901



VIBRO-PADS

Specifications are subject to change without notice or obligation

BLOWER ASSEMBLIES

Direct Drive Blowers



Applications: Residential & Light Commercial

For performance information please see next page

Blowers



BOTTOM HORIZONTAL

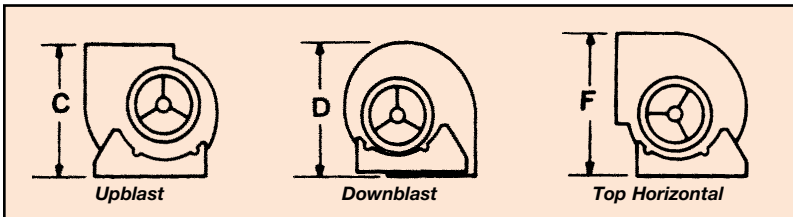
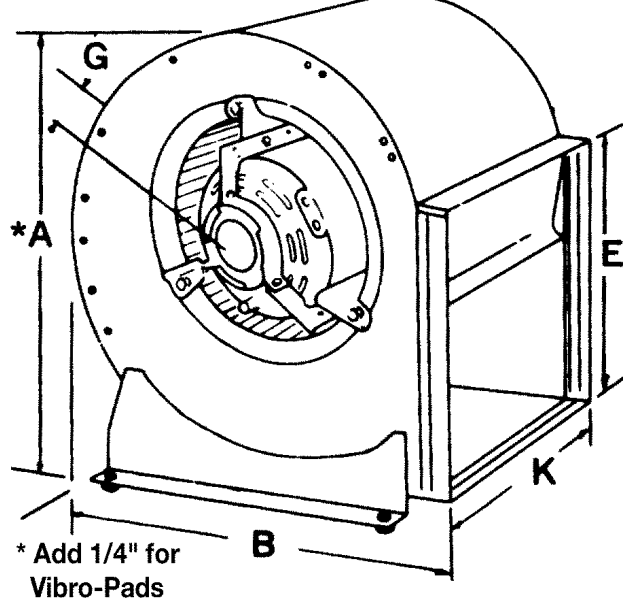

DIRECT DRIVE BLOWER ASSEMBLIES CONSIST OF:

- Heavy gauge steel blower
- Blower wheel
- Adjustable motor mounting bracket
- Vibro-Pads
- Universal housing supports

DIRECT DRIVE DIMENSIONS – CW* ROTATION

Part Number	Model Number	K	E	A	B	C	D	F	G†	Shaft Size
38251301M	DD9-7A	9 ³ / ₁₆	10 ¹ / ₄	17	14 ¹⁵ / ₁₆	15 ¹ / ₁₆	14 ¹⁵ / ₁₆	15 ⁹ / ₁₆	1 ¹ / ₄	1/2" Bore
38251302M	DD9-9A	11 ⁷ / ₈	10 ¹ / ₄	17	14 ¹⁵ / ₁₆	15 ¹ / ₁₆	14 ¹⁵ / ₁₆	15 ⁹ / ₁₆	7/8	1/2" Bore
38251303M	DD10-8A	10 ¹ / ₂	11 ³ / ₈	18 ⁷ / ₈	16 ¹ / ₂	16 ¹¹ / ₁₆	16 ¹ / ₂	17 ¹ / ₂	1 ¹ / ₈	1/2" Bore
38251304M	DD10-10A	13 ¹ / ₁₆	11 ³ / ₈	18 ⁷ / ₈	16 ¹ / ₂	16 ¹¹ / ₁₆	16 ¹ / ₂	17 ¹ / ₂	5/8	1/2" Bore
02484028M	DD12-9A	12 ¹ / ₄	13 ⁷ / ₁₆	21 ⁷ / ₈	19 ³ / ₈	19 ¹ / ₂	19 ³ / ₈	20 ¹ / ₂	1 ⁵ / ₁₆	1/2" Bore
02484029M	DD12-12A	15 ⁵ / ₈	13 ⁷ / ₁₆	21 ⁷ / ₈	19 ³ / ₈	19 ¹ / ₂	19 ³ / ₈	20 ¹ / ₂	1 ⁵ / ₁₆	1/2" Bore

† Dimensions are maximum and will vary slightly with motor sizes.

Continued on next page

To select a Direct Drive Blower, choose the matching dimensions K and E above, to match the application. Other dimensions are not as critical, assuming overall dimensions do not exceed available space.

Specifications are subject to change without notice or obligation

DIRECT DRIVE BLOWER PERFORMANCE

The following Performance Data assumes use of an off-the-shelf, 1075 RPM motor.
For exact performance in your application, contact Lau.

Model Number	Motor HP (High Speed)	.5 SP	.6 SP	.7 SP	.8 SP	.9 SP	1.0 SP	1.1 SP	1.2 SP	1.3 SP	1.4 SP	1.5 SP	1.6 SP
DD 9-7	1/4	—	—	1220	1170	1100	980	—	—	—	—	—	—
DD 9-7	1/3	1470	1490	1290	1330	1250	1100	—	—	—	—	—	—
DD 9-9	1/4	1330	1290	1240	1160	1000	—	—	—	—	—	—	—
DD 9-9	1/3	1560	1490	1430	1320	1150	—	—	—	—	—	—	—
DD 9-9	1/2	1820	1730	1620	1480	1260	—	—	—	—	—	—	—
DD10-8	1/4	—	—	—	—	—	1195	1130	1020	—	—	—	—
DD10-8	1/3	—	—	—	—	1460	1410	1360	1270	1100	—	—	—
DD10-8	1/2	—	2130	2070	2000	1930	1840	1740	1620	1450	—	—	—
DD10-10	1/3	—	—	—	—	1520	1460	1350	1000	—	—	—	—
DD10-10	1/2	—	2300	2220	2140	2060	1950	1800	1500	—	—	—	—
DD11-10*	1/2	—	—	—	—	—	—	2160	2070	1950	1750	—	—
DD12-9	1/2	—	—	—	—	—	—	—	—	1950	1910	1850	1740
DD12-12	1/2	—	—	—	—	—	—	2150	2080	1950	1600	—	—

* Reference

PREVENTATIVE MAINTENANCE FOR DIRECT DRIVE BLOWERS

Show the homeowner how they can perform basic service on the blower:



CAUTION: Make sure all electrical power is turned off and locked out to furnace or air conditioning unit before performing any maintenance.

- Follow motor manufacturer's instructions on motor nameplate.
- Oil the motor seasonally with medium weight (SAE 20) motor oil.
- Vacuum the blower and blower compartment seasonally.
- Change filters seasonally and replace when dirty.



SHIPPING NOTE:

Most Lau products can be shipped normal parcel shipping services, such as FedEx or UPS, but, some products are too large and must be shipped via common carrier.

Next Day or 2nd Day parcel services can be used to ship items at special handling costs. Because the majority of items in this catalog are bulky, we recommend checking with our Customer Service Representatives to verify pricing of expedited service.

Specifications are subject to change without notice or obligation

BLOWER WHEELS

Single Inlet, Galvanized



Manufactured for OEM Applications



- **Can be bored to fit odd or larger sizes up to 5/8"**
- **Use for packaged terminal air conditioners (PTAC) systems, room air conditioners, fan coil units, draft inducers, power burners and heaters**
- **Can combine two to replace double inlet wheels (see Technical Tip on Page 43)**

SINGLE INLET GALVANIZED

Lau Part Number	Max. RPM	Dia.	Width	Rot.	Bore Size	OEM Applications
02895766	4500	3 ¹³ / ₁₆ "	1 ¹ / ₃₂ "	CW	1/4"	Draft Inducers
02895767	4500	3 ¹³ / ₁₆ "	1 ¹ / ₃₂ "	CCW	1/4"	Draft Inducers
02895768	4500	3 ¹³ / ₁₆ "	1 ⁷ / ₈ "	CW	5/16"	Draft Inducers, Evcon
02895769	4500	3 ¹³ / ₁₆ "	1 ⁷ / ₈ "	CCW	5/16"	Draft Inducers
02895770	4500	3 ¹³ / ₁₆ "	2 ¹ / ₂ "	CW	5/16"	Draft Inducers, Reznor
02895771	4500	3 ¹³ / ₁₆ "	2 ¹ / ₂ "	CCW	5/16"	Draft Inducers, Reznor
02895772	4500	3 ²⁷ / ₃₂ "	1 ¹ / ₄ "	CW	1/4"	Carrier, Draft Inducers
02895773	4500	3 ²⁷ / ₃₂ "	1 ¹ / ₄ "	CCW	1/4"	Carrier, Draft Inducers
02895774	4500	4"	1 ¹ / ₂ "	CCW	5/16"	Lennox, Carrier
02895775	4500	4"	2 ¹ / ₂ "	CCW	1/4"	Carrier, Amana, Draft Inducers
02895776	4500	4 ¹ / ₄ "	2"	CCW	1/4"	Carrier, Draft Inducers
02895721	4500	4 ¹ / ₄ "	2 ¹ / ₂ "	CW	3/8"	
02895722	4500	4 ¹ / ₄ "	2 ¹ / ₂ "	CCW	3/8"	
02895777	4500	4 ¹ / ₄ "	2 ¹⁵ / ₁₆ "	CCW	1/4"	Lennox, Carrier, Draft Inducers
02895725	3450	4 ³ / ₄ "	2 ¹ / ₁₆ "	CW	1/2"	
02895726	3450	4 ³ / ₄ "	2 ¹ / ₁₆ "	CCW	1/2"	
02895727	3450	4 ³ / ₄ "	2 ¹ / ₂ "	CW	1/2"	
02895728	3450	4 ³ / ₄ "	2 ¹ / ₂ "	CCW	1/2"	
02895729	3450	4 ³ / ₄ "	2 ¹⁵ / ₁₆ "	CW	1/2"	
02895730	3450	4 ³ / ₄ "	2 ¹⁵ / ₁₆ "	CCW	1/2"	
02895731	3450	4 ³ / ₄ "	3 ⁷ / ₁₆ "	CW	1/2"	
02895732	3450	4 ³ / ₄ "	3 ⁷ / ₁₆ "	CCW	1/2"	
02895733	3450	5 ¹ / ₄ "	2 ¹ / ₁₆ "	CW	1/2"	
02895734	3450	5 ¹ / ₄ "	2 ¹ / ₁₆ "	CCW	1/2"	
02895735	3450	5 ¹ / ₄ "	2 ¹ / ₂ "	CW	1/2"	Carrier
02895736	3450	5 ¹ / ₄ "	2 ¹ / ₂ "	CCW	1/2"	Carrier

Maximum Operating Temperature, 200°F.

Continued on next page

Specifications are subject to change without notice or obligation



BLOWER WHEELS

Single Inlet, Galvanized

Manufactured for OEM Applications

SINGLE INLET GALVANIZED

Lau Part Number	Max. RPM	Dia.	Width	Rot.	Bore Size	OEM Applications
02895737	3450	5 ¹ / ₄ "	2 ¹⁵ / ₁₆ "	CW	1/2"	
02895738	3450	5 ¹ / ₄ "	2 ¹⁵ / ₁₆ "	CCW	1/2"	
02895739	3450	5 ¹ / ₄ "	3 ⁷ / ₁₆ "	CW	1/2"	
02895740	5700	5 ¹ / ₄ "	3 ⁷ / ₁₆ "	CCW	1/2"	
02895778	5700	5 ⁵ / ₈ "	1 ⁹ / ₁₆ "	CCW	5/16"	Carrier, Draft Inducers
02895753	3450	5 ³ / ₄ "	2 ¹ / ₁₆ "	CW	1/2"	
02895754	3450	5 ³ / ₄ "	2 ¹ / ₁₆ "	CCW	1/2"	
02895755	3450	5 ³ / ₄ "	2 ¹ / ₂ "	CW	1/2"	
02895756	3450	5 ³ / ₄ "	2 ¹ / ₂ "	CCW	1/2"	
02895757	3450	5 ³ / ₄ "	2 ¹⁵ / ₁₆ "	CW	1/2"	
02895758	3450	5 ³ / ₄ "	2 ¹⁵ / ₁₆ "	CCW	1/2"	
02895759	3450	5 ³ / ₄ "	3 ⁷ / ₁₆ "	CW	1/2"	Friedrich
02895760	3450	5 ³ / ₄ "	3 ⁷ / ₁₆ "	CCW	1/2"	
02895761	3450	5 ³ / ₄ "	3 ¹³ / ₁₆ "	CW	1/2"	
02895762	3450	5 ³ / ₄ "	3 ¹³ / ₁₆ "	CCW	1/2"	
02895779	2800	5 ³ / ₄ "	4"	CW	1/2"	
02895780	2800	5 ³ / ₄ "	4"	CCW	1/2"	
02895781	3450	6 ¹ / ₄ "	4"	CW	1/2"	
02895782	3450	6 ¹ / ₄ "	4"	CCW	1/2"	
02895751	3450	6 ¹ / ₄ "	4 ¹ / ₄ "	CW	1/2"	
02895752	3450	6 ¹ / ₄ "	4 ¹ / ₄ "	CCW	1/2"	
02895741	3450	6 ⁵ / ₁₆ "	2 ¹ / ₁₆ "	CW	1/2"	
02895742	3450	6 ⁵ / ₁₆ "	2 ¹ / ₁₆ "	CCW	1/2"	
02895743	3450	6 ⁵ / ₁₆ "	2 ¹ / ₂ "	CW	1/2"	
02895744	3450	6 ⁵ / ₁₆ "	2 ¹ / ₂ "	CCW	1/2"	
02895745	3450	6 ⁵ / ₁₆ "	2 ¹⁵ / ₁₆ "	CW	1/2"	
02895746	3450	6 ⁵ / ₁₆ "	2 ¹⁵ / ₁₆ "	CCW	1/2"	
02895747	3450	6 ⁵ / ₁₆ "	3 ⁷ / ₁₆ "	CW	1/2"	
02895748	3450	6 ⁵ / ₁₆ "	3 ⁷ / ₁₆ "	CCW	1/2"	
02895749	3450	6 ⁵ / ₁₆ "	3 ¹³ / ₁₆ "	CW	1/2"	
02895750	3450	6 ⁵ / ₁₆ "	3 ¹³ / ₁₆ "	CCW	1/2"	
02049153	4000	7 ³ / ₃₂ "	3 ⁵ / ₃₂ "	CW	1/2"	
02049154	4000	7 ³ / ₃₂ "	3 ⁵ / ₃₂ "	CCW	1/2"	
02049155	3000	7 ³ / ₃₂ "	4"	CW	1/2"	Carrier

Maximum Operating Temperature, 200°F.

Continued on next page

Specifications are subject to change without notice or obligation

BLOWER WHEELS

Single Inlet, Galvanized



Manufactured for OEM Applications

SINGLE INLET GALVANIZED

Lau Part Number	Max. RPM	Dia.	Width	Rot.	Bore Size	OEM Applications
02049156	3000	7 ³ / ₃₂ "	4"	CCW	1/2"	Carrier
02049115	2500	7 ⁷ / ₁₆ "	2 ¹ / ₄ "	CW	1/2"	
02049142	2500	7 ⁷ / ₁₆ "	2 ¹ / ₄ "	CCW	1/2"	
02049124	1650	7 ⁷ / ₁₆ "	2 ³ / ₄ "	CW	1/2"	
02049125	1650	7 ⁷ / ₁₆ "	2 ³ / ₄ "	CCW	1/2"	
02049137	1650	7 ⁷ / ₁₆ "	3 ¹ / ₂ "	CW	1/2"	
02049120	1650	7 ⁷ / ₁₆ "	3 ¹ / ₂ "	CCW	1/2"	
02049157	5400	7 ¹ / ₂ "	2"	CW	1/2"	
02049158	5400	7 ¹ / ₂ "	2"	CCW	1/2"	
02049159	4800	7 ¹ / ₂ "	2 ¹ / ₂ "	CW	1/2"	
02049160	4800	7 ¹ / ₂ "	2 ¹ / ₂ "	CCW	1/2"	
02049161	2000	7 ¹ / ₂ "	2 ³ / ₄ "	CW	1/2"	
02049162	2000	7 ¹ / ₂ "	2 ³ / ₄ "	CCW	1/2"	
02049163	4000	7 ¹ / ₂ "	3 ⁵ / ₃₂ "	CW	1/2"	
02049164	4000	7 ¹ / ₂ "	3 ⁵ / ₃₂ "	CCW	1/2"	
02049165	3000	7 ¹ / ₂ "	4"	CW	1/2"	Carrier
02049166	3000	7 ¹ / ₂ "	4"	CCW	1/2"	Carrier
02048763	4000	8"	3 ³ / ₁₆ "	CW	1/2"	
02048764	4000	8"	3 ³ / ₁₆ "	CCW	1/2"	
02048765	3000	8"	4"	CW	1/2"	
02048766	3000	8"	4"	CCW	1/2"	
02048767	4000	8 ¹ / ₂ "	3 ³ / ₁₆ "	CW	1/2"	
02048768	4000	8 ¹ / ₂ "	3 ³ / ₁₆ "	CCW	1/2"	
02048705	1650	8 ¹ / ₂ "	4"	CW	1/2"	
02048706	1650	8 ¹ / ₂ "	3 ³ / ₄ "	CCW	1/2"	
02048769	3000	8 ¹ / ₂ "	4"	CW	1/2"	
02048770	3000	8 ¹ / ₂ "	4"	CCW	1/2"	
02048771	1400	8 ¹ / ₂ "	4 ¹ / ₄ "	CW	1/2"	
02048772	1750	8 ¹ / ₂ "	4 ¹ / ₄ "	CCW	1/2"	
02048738	1750	8 ¹ / ₂ "	4 ¹ / ₂ "	CW	1/2"	
02048739	1750	8 ¹ / ₂ "	4 ¹ / ₂ "	CCW	1/2"	
02055338	1750	9"	5"	CW	1/2"	
02055339	1750	9"	5"	CCW	1/2"	
02055301	1750	9 ¹ / ₈ "	3 ³ / ₄ "	CW	1/2"	

Maximum Operating Temperature, 200°F.

Continued on next page

Specifications are subject to change without notice or obligation

SINGLE INLET GALVANIZED

Lau Part Number	Max. RPM	Dia.	Width	Rot.	Bore Size	OEM Applications
02055303	1750	9 $\frac{1}{8}$ "	3 $\frac{3}{4}$ "	CCW	$\frac{1}{2}$ "	
02055302	1750	9 $\frac{1}{8}$ "	4 $\frac{1}{4}$ "	CW	$\frac{1}{2}$ "	Carrier
02055304	1750	9 $\frac{1}{8}$ "	4 $\frac{1}{4}$ "	CCW	$\frac{1}{2}$ "	Carrier
01351110	1750	9 $\frac{15}{16}$ "	6"	CCW	$\frac{5}{8}$ "	Fedders
02055340	2600	10"	4"	CW	$\frac{1}{2}$ "	Thermadore
02055341	2600	10"	4"	CCW	$\frac{1}{2}$ "	

Maximum Operating Temperature, 200°F

TECHNICAL TIP:

Double Inlet Wheels may be duplicated in the field using Single Inlet Wheels by:

1. Using one CW and one CCW single wheel back to back (may be different widths to make up space required, but diameters must be the same).
2. For wheels too close to apparatus to reach with a wrench, tighten wheels to shaft by using extended "T" Allen wrench inserted through a notch in one of the blades in each wheel.
3. **CAUTION:** To avoid potential vibration, allow slight air gap (min. 1/32") between wheels.



CAUTION: To avoid potential vibration, allow slight air gap (min. 1/32") between wheels.

Rotation from closed end backplate

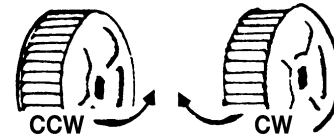

STEEL SHAFT ADAPTER BUSHINGS

(Use to reduce wheel bore size)



- Use when a smaller bore diameter is required but not readily available
- Zinc finish
- One bushing per hub

Part Number	Diameter		Length
	O.D.	I.D.	
02942101	$\frac{5}{16}$ "	$\frac{1}{4}$ "	1"
02942102	$\frac{3}{8}$ "	$\frac{1}{4}$ "	1 $\frac{1}{16}$ "
02942103	$\frac{3}{8}$ "	$\frac{5}{16}$ "	1 $\frac{1}{16}$ "
02942104	$\frac{1}{2}$ "	$\frac{5}{16}$ "	1 $\frac{1}{16}$ "
02942105	$\frac{1}{2}$ "	$\frac{3}{8}$ "	1 $\frac{1}{16}$ "
02942106	$\frac{5}{8}$ "	$\frac{1}{2}$ "	1 $\frac{15}{16}$ "
02942107	$\frac{3}{4}$ "	$\frac{5}{8}$ "	1 $\frac{1}{4}$ "

Must be ordered in multiples of 6.

BLOWER WHEELS

Lau FGP & BD Series Blowers



Applications: Ventilating, Air Conditioning, Exhausting, Processing & General Industrial

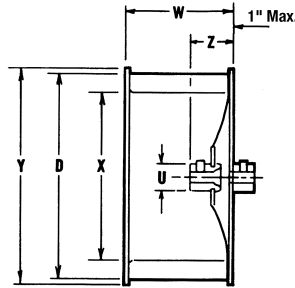

- **Steel galvanized, single inlet construction**
- **10" - 18" diameter are spun assembled**
- **22" - 30" diameter are precision riveted**

SINGLE INLET GALVANIZED FOR LAU FGP & BD SERIES

Part Number	Wheel Model	Bore Size	Rot.	Max. Wheel Cage RPM	Y	W	D	X	U	Z	No. Hubs	Hub Loc.	No. Setscrews Per Hub	Key-Way
01239857	SI 10-6A	3/4"	CW	1650	11 1/8	6	10 3/8	8 3/8	1 1/8	2 5/16	1	In	2	None
01239858	SI 10-6A	3/4"	CCW	1650	11 1/8	6	10 3/8	8 3/8	1 1/8	2 5/16	1	In	2	None
01474708	SI 12-6A	3/4"	CW	1350	13 3/16	6	12 3/8	10 3/16	1 1/8	2 5/16	1	In	2	None
01474709	SI 12-6A	3/4"	CCW	1350	13 3/16	6	12 3/8	10 3/16	1 1/8	2 5/16	1	In	2	None
01452801	SI 15-6A	1"	CW	1200	15 1/2	6	15	12 3/8	1 1/8	3 3/16	1	In	2	None
01452803	SI 15-6A	1"	CCW	1200	15 1/2	6	15	12 3/8	1 1/8	3 3/16	1	In	2	None
02074001	SI 15-9A	1"	CW	1050	15 1/2	9 1/2	15	12 5/8	1 1/8	3 3/16	2	In-Out	2-0	None
02074004	SI 15-9A	1"	CCW	1050	15 1/2	9 1/2	15	12 5/8	1 1/8	3 3/16	2	In-Out	2-0	None
02020203	SI 18-9A	1"	CW	1050	18 3/8	9	18 3/8	14 1/16	2 3/8	2 5/16	2	In-Out	1-0	1/4 x 1/8
02020204	SI 18-9A	1"	CCW	1050	18 3/8	9	18 3/8	14 1/16	2 3/8	2 5/16	2	In-Out	1-0	1/4 x 1/8
02618601	SI 18-13A	1"	CW	960	18 3/8	13 1/2	18 3/8	14 1/16	2 3/8	3 3/16	2	In-Out	1-1	1/4 x 1/8
02618602	SI 18-13A	1"	CCW	960	18 3/8	13 1/2	18 3/8	14 1/16	2 3/8	3 3/16	2	In-Out	1-1	1/4 x 1/8
01996503 ⁺ A	SI 22-11K	1 1/16"	CW	900	23 3/8	11 1/4	22	17 3/8	2 3/8	3 1/2	2	In-Out	2-1	1/4 x 1/8
01996506 ⁺ A	SI 22-11K	1 1/16"	CCW	900	23 3/8	11 1/4	22	17 3/8	2 3/8	3 1/2	2	In-Out	2-1	1/4 x 1/8
01996605 ⁺	SI 25-12K	1 3/16"	CW	750	26 3/8	12 3/4	25	20 3/8	2 3/8	3 1/2	2	In-Out	2-1	1/4 x 1/8
01996604 ⁺	SI 25-12K	1 3/16"	CCW	750	26 3/8	12 3/4	25	20 3/8	2 3/8	3 1/2	2	In-Out	2-1	1/4 x 1/8
02107103 ⁺	SI 27 1/2-14K	1 1/16"	CW	700	28 3/8	13 15/16	27 1/2	23 3/8	2 3/8	3 1/2	2	In-Out	2-1	1/4 x 1/8
02107104 ⁺	SI 27 1/2-14K	1 1/16"	CCW	700	28 3/8	13 15/16	27 1/2	23 3/8	2 3/8	3 1/2	2	In-Out	2-1	1/4 x 1/8
02107203 ⁺	SI 30-15K	1 1/16"	CW	625	31 1/8	15 3/16	30	25 3/8	2 3/8	4 1/8	2	In-Out	2-1	1/4 x 1/8
02107204 ⁺	SI 30-15K	1 1/16"	CCW	625	31 1/8	15 3/16	30	25 3/8	2 3/8	4 1/8	2	In-Out	2-1	1/4 x 1/8

Maximum Operating Temperature, 200°F. * Braced + Must ship via common carrier. ^A Special Order Only – allow 2 to 6 weeks lead time.

Specifications are subject to change without notice or obligation

Rotation is Determined by Viewing from the Hub Side



DOUBLE INLET

Part Number	Diameter	Width	Rotation	Bore Size	RPM
02895808	4 ³ / ₄ "	5 ¹ / ₈ "	CW	1/2"	3450
02895814	4 ³ / ₄ "	5 ¹ / ₈ "	CCW	1/2"	3450
02895801	4 ³ / ₄ "	6 ⁷ / ₈ "	CW	1/2"	3450
02895815	4 ³ / ₄ "	6 ⁷ / ₈ "	CCW	1/2"	3450
02895802	5 ¹ / ₄ "	5 ⁷ / ₈ "	CW	1/2"	3450
02895816	5 ¹ / ₄ "	5 ⁷ / ₈ "	CCW	1/2"	3450
02895818	5 ¹ / ₄ "	6 ³ / ₄ "	CW	1/2"	3450
02895817	5 ¹ / ₄ "	6 ³ / ₄ "	CCW	1/2"	3450
02895803	5 ¹ / ₄ "	6 ⁷ / ₈ "	CW	1/2"	3450
02895819	5 ¹ / ₄ "	6 ⁷ / ₈ "	CCW	1/2"	3450
02895804	5 ³ / ₄ "	5 ⁷ / ₈ "	CW	1/2"	3450
02895820	5 ³ / ₄ "	5 ⁷ / ₈ "	CCW	1/2"	3450
02895805	5 ³ / ₄ "	6 ⁷ / ₈ "	CW	1/2"	3450
02895821	5 ³ / ₄ "	6 ⁷ / ₈ "	CCW	1/2"	3450
02895822	5 ³ / ₄ "	7 ⁵ / ₈ "	CW	1/2"	3450
02895823	5 ³ / ₄ "	7 ⁵ / ₈ "	CCW	1/2"	3450
02895824	5 ³ / ₄ "	8"	CW	1/2"	3450
02895825	5 ³ / ₄ "	8"	CCW	1/2"	3450
02895806	5 ³ / ₄ "	8 ¹ / ₂ "	CW	1/2"	3450
02895826	5 ³ / ₄ "	8 ¹ / ₂ "	CCW	1/2"	3450
02895827	6 ⁵ / ₁₆ "	6 ³ / ₈ "	CW	3/4"	3450
02895828	6 ⁵ / ₁₆ "	6 ³ / ₈ "	CCW	3/4"	3450
02895807	6 ⁵ / ₁₆ "	7 ⁵ / ₈ "	CW	1/2"	3450
02895829	6 ⁵ / ₁₆ "	7 ⁵ / ₈ "	CCW	1/2"	3450
02895832	7 ¹ / ₂ "	4"	CW	3/4"	2500
02895833	7 ¹ / ₂ "	4"	CCW	3/4"	2500
02895834	7 ¹ / ₂ "	5"	CW	3/4"	2500
02895835	7 ¹ / ₂ "	5"	CCW	3/4"	2500
02895836	7 ¹ / ₂ "	6 ¹¹ / ₃₂ "	CW	3/4"	1800
02895837	7 ¹ / ₂ "	6 ¹¹ / ₃₂ "	CCW	3/4"	1800

Maximum Operating Temperature, 150°F.

Specifications are subject to change without notice or obligation

BLOWER WHEELS

Double Inlet, Direct Drive



Lau's Universal Replacement Wheel



- Galvanized, Universal Replacement wheels
- 9"–11" double inlet with precise blade spacing and consistency in alignment and balance
- Quiet performance, forward curved wheel
- Preslok® Center disc with a special hub for use with direct drive blowers

DOUBLE INLET, DIRECT DRIVE WHEELS

Part Number	Lau Model	Bore Size	Rot.	Center Disc.	Max. RPM	D	W	X	U	Z	H
01333401	DD 9-4A	1/2"	CW	Convex	1750	9 1/2	4 1/2	7 11/16	1 1/4	1 25/32	43
01333501	DD 9-6A	1/2"	CW	Convex	1750	9 1/2	6	7 11/16	1 1/4	1 25/32	43
01333602	DD 9-7A	1/2"	CW	Convex	1750	9 1/2	7 1/8	7 11/16	1 1/4	1 25/32	43
01333603	DD 9-7A	1/2"	CCW	Convex	1750	9 1/2	7 1/8	7 11/16	1 1/4	1 25/32	43
01333701	DD 9-8A	1/2"	CW	Convex	1750	9 1/2	8	7 11/16	1 1/4	1 25/32	43
01333703	DD 9-8A	1/2"	CCW	Convex	1750	9 1/2	8	7 11/16	1 1/4	1 25/32	43
01333201	DD 9-9A	1/2"	CW	Concave	1750	9 1/2	9 1/2	7 11/16	1 1/4	7/32	43
01333203	DD 9-9A	1/2"	CCW	Concave	1750	9 1/2	9 1/2	7 11/16	1 1/4	7/32	43
01332701	DD10-4A	1/2"	CW	Convex	1750	10 5/8	4 1/2	8 7/8	1 1/4	1 15/16	48
01332601	DD10-6A	1/2"	CW	Convex	1750	10 5/8	6	8 7/8	1 1/4	1 15/16	48
01332602	DD10-6A	1/2"	CCW	Convex	1750	10 5/8	6	8 7/8	1 1/4	1 15/16	48
01332614	DD10-6A	5/8"	CW	Convex	1750	10 5/8	6	8 7/8	1 1/4	1 15/16	48
01332501	DD10-7A	1/2"	CW	Convex	1750	10 5/8	7 1/8	8 7/8	1 1/4	1 15/16	48
02710204	DD10-7A	1/2"	CCW	Convex	1750	10 5/8	7 1/8	8 7/8	1 1/4	1 15/16	48
01332401	DD10-8A	1/2"	CW	Convex	1750	10 5/8	8	8 7/8	1 1/4	1 15/16	48
01332402	DD10-8A	1/2"	CCW	Convex	1750	10 5/8	8	8 7/8	1 1/4	1 15/16	48
01331701	DD10-9A	1/2"	CW	Concave	1750	10 5/8	9 1/2	8 7/8	1 1/4	1/16	48
01331704	DD10-9A	1/2"	CCW	Concave	1750	10 5/8	9 1/2	8 7/8	1 1/4	1/16	48
01332301	DD10-9A	1/2"	CW	Convex	1750	10 5/8	9 1/2	8 7/8	1 1/4	1 15/16	48
01331602	DD10-10A	1/2"	CW	Concave	1750	10 5/8	10 5/8	8 7/8	1 1/4	1/16	48
01332203	DD10-10A	1/2"	CW	Convex	1750	10 5/8	10 5/8	8 7/8	1 1/4	1 15/16	48
01331606	DD10-10A	1/2"	CCW	Concave	1750	10 5/8	10 5/8	8 7/8	1 1/4	1/16	48
02694003	DD11-6A	1/2"	CW	Convex	1550	11 3/4	6	10	1 1/4	2	53
02694005	DD11-7A	1/2"	CW	Convex	1550	11 3/4	7 1/8	10	1 1/4	2	53
02694007	DD11-8A	1/2"	CW	Convex	1550	11 3/4	8	10	1 1/4	2	53
02694107	DD11-8A	1/2"	CW	Concave	1550	11 3/4	8	10	1 1/4	1/16	53
02694008	DD11-8A	1/2"	CCW	Convex	1550	11 3/4	8	10	1 1/4	2	53

TEMPERATURE: Due to temperature limitations of most motors, these wheels are recommended for application temperatures that do not exceed 135°F (60°C). Wheels are rated to 200°F.

Continued on next page.

Specifications are subject to change without notice or obligation

DOUBLE INLET, DIRECT DRIVE WHEELS

Part Number	Lau Model	Bore Size	Rot.	Center Disc.	Max. RPM	D	W	X	U	Z	H
02694009	DD11-9A	1/2"	CW	Convex	1550	11 3/4	9 1/2	10	1 1/4	2	53
02694010	DD11-9A	1/2"	CCW	Convex	1550	11 3/4	9 1/2	10	1 1/4	2	53
02694111	DD11-10A	1/2"	CW	Concave	1550	11 3/4	10 5/8	10	1 1/4	1/16	53
02694112	DD11-10A	1/2"	CCW	Concave	1550	11 3/4	10 5/8	10	1 1/4	1/16	53
01369325	DD12-9A	1/2"	CW	Convex	1200	12 5/8	9 1/2	10 5/16	1 1/4	2	43
01369315	DD12-9A	5/8"	CW	Convex	1200	12 5/8	9 1/2	10 5/16	1 1/4	2	43
01556507	DD12-12A	1/2"	CW	Concave	1200	12 5/8	12 5/8	10 5/16	1 1/4	1/16	43
01556504	DD12-12A	5/8"	CW	Concave	1200	12 5/8	12 5/8	10 5/16	1 1/4	1/16	43

TEMPERATURE: Due to temperature limitations of most motors, these wheels are recommended for application temperatures that do not exceed 135°F (60°C). Wheels are rated to 200°F.

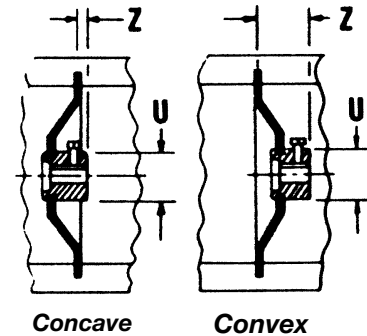
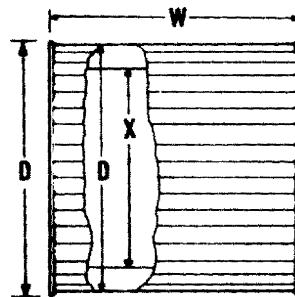
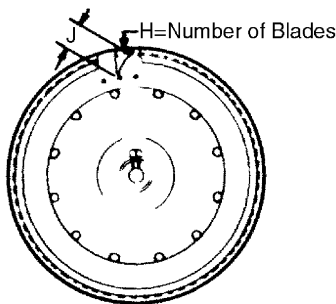

- J = 1" on all models through 11"
- J = 1 5/16" on 12" and 15" models
- J = 1 15/16" on 18" and 20" models

SERVICE TIP

If opposite rotation is required, mount motor on hub side. Setscrew must be converted to Allen head screw and then tightened through the blades, using a "T" Allen wrench. (You may have to notch blade above setscrew to provide access for "T" Allen wrench.)

For higher RPM capability see Torque Guide Chart on Page 60.



Call your Customer Service Representative today for applications requiring galvanized wheels!!

BLOWER WHEELS

Double Inlet, Belt Drive



Applications: Heating & Air Conditioning



- Galvanized, Universal Replacement Preslok® wheels
- Two hubs with center disc mechanically attached to each blade
- Strong Construction, CW or CCW rotation

DOUBLE INLET – BELT DRIVE

Part Number	Lau Model	Bore Size	Set Screw	Key Way	Max. RPM	Y	W	D	X	U	Z	H
00866612	A9-6A	3/4	1	3/16 X 3/32	4000	9 1/2	6	9 1/2	7 11/16	1 1/4	2 15/16	43
00862112	A9-7A	3/4	1	3/16 X 3/32	3300	9 1/2	7 1/8	9 1/2	7 11/16	1 1/4	2 15/16	43
00851912	A9-9A	3/4	1	3/16 X 3/32	2400	9 1/2	9 1/2	9 1/2	7 11/16	1 1/4	2 15/16	43
00851916	A9-9A	1	1	1/4 X 1/8	2400	9 1/2	9 1/2	9 1/2	7 11/16	1 3/4	2 7/8	43
01223712	A10-4A	3/4	1	3/16 X 3/32	3900	10 5/8	4 1/2	10 5/8	8 7/8	1 1/4	3 9/32	48
00836412	A10-6A	3/4	1	3/16 X 3/32	3900	10 5/8	6	10 5/8	8 7/8	1 1/4	3 9/32	48
00836312	A10-7A	3/4	1	3/16 X 3/32	3100	10 5/8	7 1/8	10 5/8	8 7/8	1 1/4	3 9/32	48
00836112	A10-8A	3/4	1	3/16 X 3/32	3000	10 5/8	8	10 5/8	8 7/8	1 1/4	3 9/32	48
00836212	A10-9A	3/4	1	3/16 X 3/32	2300	10 5/8	9 1/2	10 5/8	8 7/8	1 1/4	3 9/32	48
00836012	A10-10A	3/4	1	3/16 X 3/32	2100	10 5/8	10 5/8	10 5/8	8 7/8	1 1/4	3 9/32	48
00836010	A10-10A	5/8	1	3/16 X 3/32	2100	10 5/8	10 5/8	10 5/8	8 7/8	1 1/4	3 9/32	48
00836016	A10-10A	1	1	1/4 X 1/8	2100	10 5/8	10 5/8	10 5/8	8 7/8	1 3/4	3 1/4	48
00897116	A12-6A	1	1	1/4 X 1/8	3800	12 5/8	6	12 5/8	10 5/16	1 3/4	3 1/2	43
02757515	A12-9A	3/4	1	3/16 X 3/32	2100	12 5/8	9 1/2	12 5/8	10 5/8	1 3/4	3 1/4	48
00850716	A12-9A	1	1	1/4 X 1/8	2500	12 5/8	9 1/2	12 5/8	10 5/16	1 3/4	3 1/2	43
00850758	A12-9A	1 3/16	1	1/4 X 1/8	2500	12 5/8	9 1/2	12 5/8	10 5/16	1 3/4	3 1/2	43
00850723	A12-9A	1 7/16	2	3/8 X 3/16	2500	12 5/8	9 1/2	12 5/8	10 5/16	2 1/2	3 7/8	43
00986716	A12-11A	1	1	1/4 X 1/8	2000	12 5/8	11 1/8	12 5/8	10 5/16	1 3/4	3 1/2	43
00840310	A12-12A	5/8	1	3/16 X 3/32	1800	12 5/8	12 5/8	12 5/8	10 5/16	1 1/4	3 3/8	43
00840301	A12-12A	3/4	1	3/16 X 3/32	1800	12 5/8	12 5/8	12 5/8	10 5/16	1 1/4	3 3/8	43
00840316	A12-12A	1	1	1/4 X 1/8	1800	12 5/8	12 5/8	12 5/8	10 5/16	1 3/4	3 1/2	43
00840393	A12-12A	1 3/16	1	1/4 X 1/8	1800	12 5/8	12 5/8	12 5/8	10 5/16	2 1/2	3 7/8	43
00840379	A12-12A	1 7/16	2	3/8 X 3/16	1800	12 5/8	12 5/8	12 5/8	10 5/16	2 1/2	3 7/8	43
00874716	A12-15A	1	1	1/4 X 1/8	1100	12 5/8	15	12 5/8	10 5/16	1 3/4	3 1/2	43
00954816	A15-9A	1	1	1/4 X 1/8	2500	15	9 1/2	15	12 5/8	1 3/4	4 1/8	51
00954870	A15-9A	1 3/16	2	1/4 X 1/8	2500	15	9 1/2	15	12 5/8	2 1/2	4 1/2	51

Maximum Operating Temperature, 200°F.

Continued on next page.

Specifications are subject to change without notice or obligation

DOUBLE INLET - BELT DRIVE

Part Number	Lau Model	Bore Size	Set Screw	Key Way	Max. RPM	Y	W	D	X	U	Z	H
00954823	A15-9A	1 ⁷ / ₁₆	2	3/8 x 3/16	2500	15	9 1/2	15	12 5/8	2 1/2	4 1/2	51
00841816	A15-11A	1	1	1/4 x 12	2100	15	11 1/8	15	12 5/8	1 3/4	4 1/8	51
00841877	A15-11A	1 3/16	1	1/4 x 12	2100	15	11 1/8	15	12 5/8	1 3/4	4 1/8	51
00841880	A15-11A	1 7/16	2	3/8 x 3/16	2100	15	11 1/8	15	12 5/8	2 1/2	4 1/2	51
00874616	A15-12A	1	1	1/4 x 12	1900	15	12 5/8	15	12 5/8	1 3/4	4 1/8	51
00827616	A15-15A	1	1	1/4 x 12	1550	15	15	15	12 5/8	1 3/4	4 1/8	51
01767137	A15-15A	1 3/16	1	1/4 x 12	1550	15	15	15	12 5/8	1 3/4	4 1/8	51
00827672	A15-15A	1 7/16	2	3/8 x 3/16	1550	15	15	15	12 5/8	2 1/2	4 1/2	51
00865916	A18-13A	1	1	1/4 x 12	1550	18 5/8	13 1/2	18 1/8	14 11/16	1 3/4	5	48
00865960	A18-13A	1 7/16	1	1/4 x 12	1550	18 5/8	13 1/2	18 1/8	14 11/16	1 3/4	5	48
00865816	A18-18A	1	1	1/4 x 12	1200	18 5/8	18	18 1/8	14 11/16	1 3/4	5	48
00865874	A18-18A	1 3/16	1	1/4 x 12	1200	18 5/8	18	18 1/8	14 11/16	1 3/4	5	48
00865887	A18-18A	1 7/16	2	3/8 x 3/16	1200	18 5/8	18	18 1/8	14 11/16	2 1/2	5 3/8	48
(A)01954002	A20-18A	1 3/16	1	1/4 x 12	1100	20 1/2	18	20	16 9/16	2 1/2	5 3/32	53
(A)01954041	A20-18A	1 7/16	2	3/8 x 3/16	1100	20 1/2	18	20	16 9/16	2 1/2	5 3/32	53
(A)01954029	A20-18A	1 11/16	1	3/8 x 3/16	1100	20 1/2	18	20	16 9/16	2 3/4	5 3/32	53
(A)01954020	A20-18A	2 15/16	1	1/2 x 1/4	1100	20 1/2	18	20	16 9/16	4 1/4	5 3/32	53
(A)02043907*	A20-18A	3*	—	N/A	1100	20 1/2	18	20	16 9/16	5 3/4	5 3/32	53
(A)02043920*	A20-18A	4*	—	N/A	1100	20 1/2	18	20	16 9/16	7 1/8	5 3/32	53

(A) These wheels are a special order with 2 - 4 weeks lead time required and **CANNOT ship by UPS.**

* Clamplok Hubs with a diameter of 1 3/16" and larger include tapped holes at 90° to keyway for accepting 2nd SS (supplied by installer).

REDUCING BUSHINGS - FOR ABOVE WHEELS ONLY

(Use to reduce wheel bore sizes)

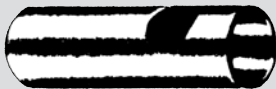

• **A 1" bore wheel can be reduced to a 3/4" bore by using bushings with a 1" O.D. and a 1/8" I.D.**

Part Number	Model / Description
02750203	1" O.D. x 3/4" I.D. x 1 1/8" long 1 1/8"

Order the quantity of bushings to match number of hubs in the wheel.

Use reducer bushings (one for each hub) if a smaller bore size is required.

NUMBER OF BLADES

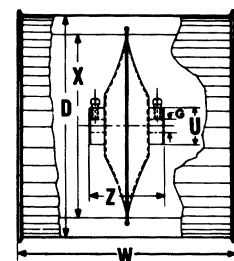
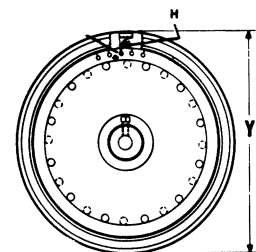

BLOWER WHEELS

Double Inlet, Large Belt Drive



Painted, Cold-Rolled Steel Weld Construction

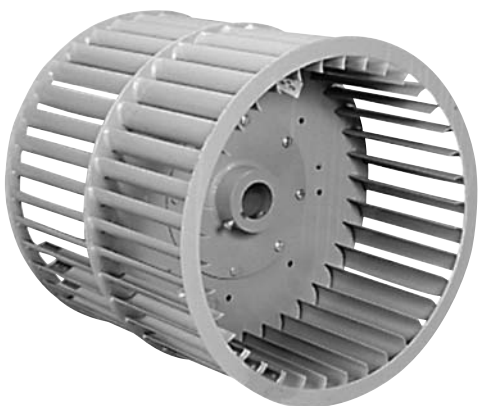

- **Forward curved, quiet efficient wheels**
- **The number of blades doesn't change with increased diameter; however, as diameter increases so does depth of blade**

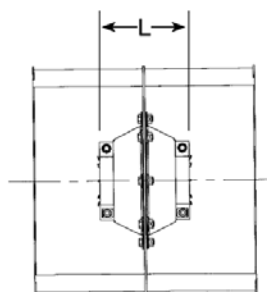
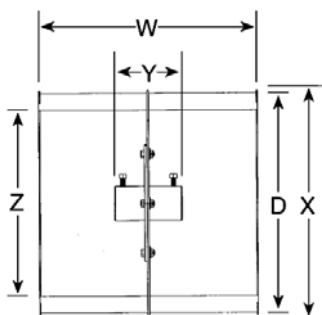
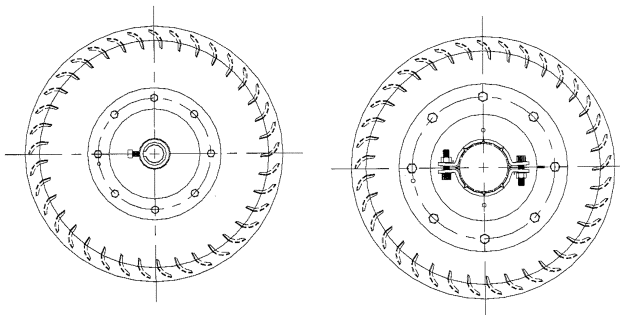

Photo View of Clamplok Hub



Standard Hub for Solid Shafts



Clamplok Hub for 1/4", 3", 4", 4 1/2" and 5" Tubular Shafts

DOUBLE INLET - LARGE BELT DRIVE

Part Number	Lau Model	Bore Size	Set Screw	Key Way	Max. RPM	No. of Blades	D	L	W	X	Y	Z
05031407	A20-20H	1 3/16	1	1/4 x 1/8	1310	37	20	6 7/8	20	20 1/2	4 11/32	16 15/16
05031403	A20-20H	1 7/16	1	3/8 x 3/16	1310	37	20	6 7/8	20	20 1/2	4 11/32	16 15/16
05031406	A20-20H	1 11/16	1	3/8 x 3/16	1310	37	20	6 7/8	20	20 1/2	4 11/32	16 15/16
05031410	A20-20H	1 15/16	1	1/2 x 1/4	1310	37	20	6 7/8	20	20 1/2	4 11/32	16 15/16
05031419	A20-20H	2 3/16	1	1/2 x 1/4	1310	37	20	6 7/8	20	20 1/2	4 11/32	16 15/16
05031203	A22-22H	1 7/16	1	3/8 x 3/16	1200	37	22 3/8	6 7/8	22	22 7/8	4 11/32	18 15/16
05031208	A22-22H	1 11/16	1	3/8 x 3/16	1200	37	22 3/8	6 7/8	22	22 7/8	4 11/32	18 15/16
05031210	A22-22H	1 15/16	1	1/2 x 1/4	1200	37	22 3/8	6 7/8	22	22 7/8	4 11/32	18 15/16
05031206	A22-22H	2 3/16	1	1/2 x 1/4	1200	37	22 3/8	6 7/8	22	22 7/8	4 11/32	18 15/16
05031003	A25-25H	1 7/16	1	3/8 x 3/16	1030	37	25	6 7/8	25	25 1/2	5	21 5/32
05031006	A25-25H	1 11/16	1	3/8 x 3/16	1030	37	25	6 7/8	25	25 1/2	5	21 5/32
05031012	A25-25H	1 15/16	1	1/2 x 1/4	1030	37	25	6 7/8	25	25 1/2	5	21 5/32
05031020	A25-25H	2 3/16	1	1/2 x 1/4	1030	37	25	6 7/8	25	25 1/2	5	21 5/32

Maximum Operating Temperature, 200°F.

Continued on next page.

Specifications are subject to change without notice or obligation

DOUBLE INLET - LARGE BELT DRIVE

Part Number	Lau Model	Bore Size	Set Screw	Key Way	Max. RPM	No. of Blades	D	L	W	X	Y	Z
05030803	A27-25H	1 ¹¹ / ₁₆	1	3/8 x 3/16	930	37	27 ⁵ / ₈	8 ⁷ / ₆₄	25	28 ¹ / ₈	5	23 ¹³ / ₃₂
05030818	A27-25H	1 ¹⁵ / ₁₆	1	1/2 x 1/4	930	37	27 ⁵ / ₈	8 ⁷ / ₆₄	25	28 ¹ / ₈	5	23 ¹³ / ₃₂
05030804	A27-27H	1 ¹¹ / ₁₆	1	3/8 x 3/16	910	37	27 ⁵ / ₈	8 ⁷ / ₆₄	27 1/2	28 ¹ / ₈	5	23 ¹³ / ₃₂
05030817	A27-27H	1 ¹⁵ / ₁₆	1	1/2 x 1/4	910	37	27 ⁵ / ₈	8 ⁷ / ₆₄	27 1/2	28 ¹ / ₈	5	23 ¹³ / ₃₂
05030811	A27-27H	2 ³ / ₁₆	1	1/2 x 1/4	910	37	27 ⁵ / ₈	8 ⁷ / ₆₄	27 1/2	28 ¹ / ₈	5	23 ¹³ / ₃₂
05030609	A30-30H	1 ¹¹ / ₁₆	1	3/8 x 3/16	850	37	30 ¹ / ₄	8 ⁷ / ₆₄	30	30 ³ / ₄	5	25 ⁵ / ₈
05030605	A30-30H	1 ¹⁵ / ₁₆	1	1/2 x 1/4	850	37	30 ¹ / ₄	8 ⁷ / ₆₄	30	30 ³ / ₄	5	25 ⁵ / ₈
05030614	A30-30H	2 ³ / ₁₆	1	1/2 x 1/4	850	37	30 ¹ / ₄	8 ⁷ / ₆₄	30	30 ³ / ₄	5	25 ⁵ / ₈
05029612	A36-30H	1 ¹⁵ / ₁₆	1	1/2 x 1/4	720	37	36	8 ⁷ / ₆₄	30	36 ¹ / ₂	5	30 ¹ / ₂
05029605	A36-30H	2 ³ / ₁₆	1	1/2 x 1/4	720	37	36	8 ⁷ / ₆₄	30	36 ¹ / ₂	5	30 ¹ / ₂
05029602	A36-30H	2 ⁷ / ₁₆	1	5/8 x 1/2	720	37	36	8 ⁷ / ₆₄	30	36 ¹ / ₂	5	30 ¹ / ₂
05029610	A36-36H	1 ¹⁵ / ₁₆	1	1/2 x 1/4	730	37	36	8 ⁷ / ₆₄	36	36 ¹ / ₂	5	30 ¹ / ₂
05029606	A36-36H	2 ³ / ₁₆	1	1/2 x 1/4	730	37	36	8 ⁷ / ₆₄	36	36 ¹ / ₂	5	30 ¹ / ₂
05029603	A36-36H	2 ⁷ / ₁₆	1	5/8 x 5/16	730	37	36	8 ⁷ / ₆₄	36	36 ¹ / ₂	5	30 ¹ / ₂

Maximum Operating Temperature, 200°F.



LARGE BELT DRIVE WHEELS ARE AVAILABLE ON A SPECIAL ORDER BASIS WITH 2-4 WEEKS LEAD TIME. THEY CANNOT SHIP VIA UPS DELIVERY.



For maximum starting torque of the hub bore size, refer to Torque Guide Chart on Page 60.



Call your Customer Service Representative today for applications requiring galvanized wheels!!



SHIPPING NOTE:

Most Lau products can be shipped normal parcel shipping services, such as FedEx or UPS, but, some products are too large and must be shipped via common carrier.

Next Day or 2nd Day parcel services can be used to ship items at special handling costs. Because the majority of items in this catalog are bulky, we recommend checking with our Customer Service Representatives to verify pricing of expedited service.

Specifications are subject to change without notice or obligation

BLOWER ASSEMBLIES

FGP Series



Applications: Ventilating, Exhausting & Air Conditioning

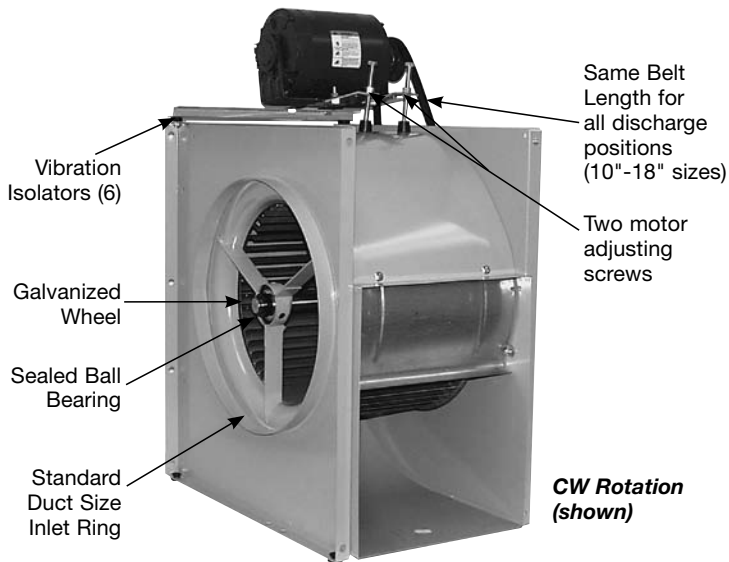

- **Forward curved, dynamically balanced wheels with ball bearings**
- **Two motor mount positions**
- **Maximum temperature 150°F; CFM: 600-19,000; 10"-30" sizes**
- **Higher RPM capability, CW and CCW rotations**

FGP SERIES

Part Number	Model Number	Rot.	Wheel Dia.	Shaft Dia.	Tip Speed (FPM)	Outlet Area	Max. RPM	Max. HP
01805102	FGP 10-6A	CW	10 ⁵ / ₈	3/4	RPM x 23/4	0.629 Ft ²	1650	1.5
01987302	FGP 10-6A	CCW	10 ⁵ / ₈	3/4	RPM x 2 ³ / ₄	0.629 Ft ²	1650	1.5
01805103	FGP 12-6A	CW	12 ⁵ / ₈	3/4	RPM x 3 ⁵ / ₁₆	0.745 Ft ²	1350	1.5
01987303	FGP 12-6A	CCW	12 ⁵ / ₈	3/4	RPM x 3 ⁵ / ₁₆	0.745 Ft ²	1350	1.5
01812502	FGP 15-9A	CW	15	1	RPM x 3 ¹⁵ / ₁₆	1.340 Ft ²	1050	2.0
01987402	FGP 15-9A	CCW	15	1	RPM x 3 ¹⁵ / ₁₆	1.340 Ft ²	1050	2.0
01805202	FGP 18-13A	CW	18 ⁷ / ₈	1	RPM x 4 ³ / ₄	2.180 Ft ²	960	3.0
01988502	FGP 18-13A	CCW	18 ⁷ / ₈	1	RPM x 4 ³ / ₄	2.180 Ft ²	960	3.0
01997202	FGP 22-11K	CW	22	1 ³ / ₁₆	RPM x 5 ³ / ₄	3.240 Ft ²	900	7.5
01997302	FGP 22-11K	CCW	22	1 ³ / ₁₆	RPM x 5 ³ / ₄	3.240 Ft ²	900	7.5
01997203	FGP 25-12K	CW	25	1 ³ / ₁₆	RPM x 6 ⁹ / ₁₆	4.350 Ft ²	750	7.5
01997303	FGP 25-12K	CCW	25	1 ³ / ₁₆	RPM x 6 ⁹ / ₁₆	4.350 Ft ²	750	7.5
02107301	FGP 27 ¹ / ₂ -14K	CW	27 ¹ / ₂	1 ⁷ / ₁₆	RPM x 7 ³ / ₁₆	4.840 Ft ²	700	15.0
02107401	FGP 27 ¹ / ₂ -14K	CCW	27 ¹ / ₂	1 ⁷ / ₁₆	RPM x 7 ³ / ₁₆	4.840 Ft ²	700	15.0
02107302	FGP 30-15K	CW	30	1 ⁷ / ₁₆	RPM x 7 ⁷ / ₈	5.480 Ft ²	625	15.0
02107402	FGP 30-15K	CCW	30	1 ⁷ / ₁₆	RPM x 7 ⁷ / ₈	5.480 Ft ²	625	15.0

DISCHARGE POSITIONS (Rotation determined from drive side of blower)

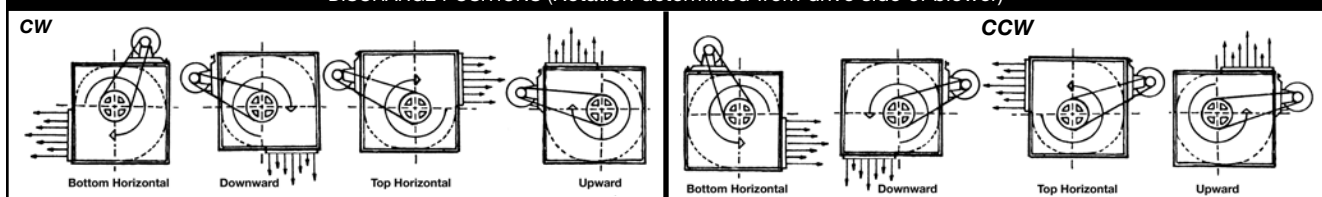

See Appendix B for Performance Charts!

Specifications are subject to change without notice or obligation

Part No.: 38251301M	
Size	DD9-7A
Blower Wheel	01333602
Housing Support Kit	01873101AC

Part No.: 0574300002M	
Size	A9-7ACE
Blower Wheel	00862112
Shaft	38209601
Housing Support Kit	01873101AC
Sleeve Bearing/Pair	38244302
Ball Bearing/Pair	38258801

Part No.: 0574310003M	
Size	A10-10ACE
Blower Wheel	00836012
Shaft	38209601
Housing Support Kit	02025501AC
Sleeve Bearing/Pair	38244302
Ball Bearing/Pair	t

Part No.: 38251302M	
Size	DD9-9A
Blower Wheel	01333201
Housing Support Kit	01873101AC

Part No.: 0574300003M	
Size	A9-9ACE
Blower Wheel	00851912
Shaft	38209601
Housing Support Kit	01873101AC
Sleeve Bearing/Pair	38244302
Ball Bearing/Pair	38258801

Part No.: 3824340022M	
Size	A12-9ACE
Blower Wheel	00850716
Shaft	38209501
Housing Support Kit	02072401AC
Sleeve Bearing/Pair	38244303
Ball Bearing/Pair	38259001

Part No.: 38251303M	
Size	DD10-8A
Blower Wheel	01332401
Housing Support Kit	02025501AC

Part No.: 38208002M	
Size	A15-15ACE
Blower Wheel	00827616
Shaft	38209501
Sleeve Bearing/Pair	38244303
Ball Bearing/Pair	38259001

Part No.: 38243420M	
Size	A12-12ACE
Blower Wheel	00840316
Shaft	38209501
Housing Support Kit	02072401AC
Sleeve Bearing/Pair	38244303
Ball Bearing/Pair	38259001

Part No.: 38251304M	
Size	DD10-10A
Blower Wheel	01331602
Housing Support Kit	02025501AC

Part No.: 382080004M	
Size	A15-11ACE
Blower Wheel	00841816
Shaft	38209501
Sleeve Bearing/Pair	38244303
Ball Bearing/Pair	38259001

Part No.: 0574310002M	
Size	A10-8ACE
Blower Wheel	00836112
Shaft	38209601
Housing Support Kit	02025501AC
Sleeve Bearing/Pair	38244302
Ball Bearing/Pair	38258801

Specifications are subject to change without notice or obligation

BLOWER PARTS & ACCESSORIES



Lau Blower Replacement Parts

Part No.: 05036406C	
Size A20-20H	
	Blower Wheel 05031406H

Part No.: 3824300003M	
Size A18-13ACE	
	Blower Wheel 00865916
	Shaft 38209501
	Sleeve Bearing/Pair 38244303
	Ball Bearing/Pair 38259001

Part No.: 38243002M	
Size A18-18ACE	
	Blower Wheel 00865816
	Shaft 38249201
	Sleeve Bearing/Pair 38244303
	Ball Bearing/Pair 38259001

Part No.: 05036506C	
Size A22-22H	
	Blower Wheel 05031206H

Part No.: 05036606C	
Size A25-25H	
	Blower Wheel 05031009H

Blower Wheels

COMPONENT LIMITS FOR BLOWER ACCESSORIES

Bearing Bracket – Maximum 1 $\frac{1}{6}$ Bore

3 Piece
(Max. 3 HP)

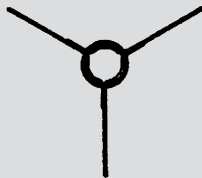

A9 through A15 blowers in this catalog contain this bracket.

1 Piece
(Max. 7 $\frac{1}{2}$ HP)

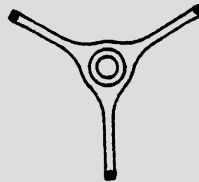

1 piece bracket standard on A18-13 ACE and A18-18 ACE blowers only.

Housing Supports
(Max. 3 HP)

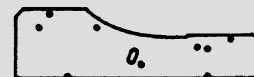

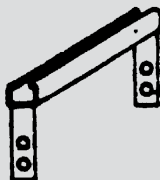

Housing Support Kits are now available for 9" to 12" blowers (see charts on Page 57 for part numbers).

Motor Mounting Bracket
(Max. $\frac{3}{4}$ HP)

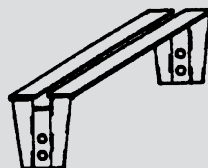

Motor Mounting Bracket
(Max. 1 $\frac{1}{2}$ HP)



 See Page 55 to order Motor Brackets for 12" and 15" blowers.

Specifications are subject to change without notice or obligation

Bracket & Bracket Kits

BOLT ON BEARING BRACKET

Come in packs of 3.

Not in stock and require a **4-6 week lead time**. There is no minimum order required.

Part No.	Fits
05486601	9" Blower
05486701	10" Blower
05486801	11" or 12" Blower
05486901	12" Blower

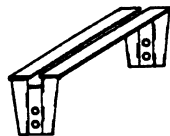
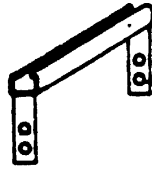

BELT DRIVE MOTOR MOUNTING BRACKETS

MOTOR BRACKET SIZE CHART (MAXIMUM 3/4 HP)

Model	A9-6	A9-7	A9-9	A10-8
Part No.	00690205	00690204	00690219	00690206

Model	A10-10	A12-9	A12-12	A15-11
Part No.	00690207	00690201	00690202	02467702

Model	A15-15	A18-13	A18-18
Part No.	02467703	00920504	00920502

MOTOR BRACKET SIZE CHART (MAXIMUM 1 1/2 HP)

Model	A9-9	A10-10	A12-12	A15-15	A18-18
Part No.	01944735	01944713	01944703	01944716	01944737

BEARING BRACKETS FOR BELT DRIVE BLOWERS



One-Piece Bracket (sold individually)

*OD as measured over rubber cushion.

Part No.	Description	A	B	OD*
00896004	18" Belt Drive Blower (1)	9 5/16"	8 13/16"	2 1/2"
01443102	15" Belt Drive Blower (1)	7 13/16"	7 7/16"	2 1/2"
01573001	12" Belt Drive Blower (1)	6 5/16"	6"	2 1/2"

NOTE: 18" version has 2 belt holes on each bracket leg.

KNOCK DOWN BRACKET KIT

For easier installation. Accommodates bearings that have 1 1/8" O.D. (Fits up to 1 1/2" bolt circle.)



Part No. (Pair)	O.D. of Rubber Cushion
38269901	1 1/8"

When combined with a pair of 3/4" Lau Bearings, can also replace obsolete flange bearing #38208201.

DIRECT DRIVE MOTOR MOUNTING BRACKETS

UNIVERSAL MOTOR MOUNTING BRACKETS

Lau's Universal Motor Mounting Brackets accommodate 10" and 12" Blowers (includes mounting hardware).

Part No. for 42-Frame Motors (5" Dia.)	Part No. for 48-Frame Motors (5 5/8" Dia.)	Blower Sizes
02869101	02869201	10"
N/A	05409101	12"

MOTOR MOUNTING BRACKET

Supported from the housing venturi, mounting brackets are adjusted for motors 3 1/2" to 6 1/2" in length and accommodates a 48-frame motor. Adjusts to various wheel widths.

Part No.	Fits
38251401	9" Blower
38251501	10" Blower
02612601	11" Blower
02612601	12" Blower



All necessary hardware furnished

FLEXIBLE MOUNT "BELLY" BAND ADAPTER

Adapts either to a 5" diameter motor (42-frame), or a 5 5/8" (48-frame) to mount on 9" and 10" Blowers.



Part No.	Fits
05407401	5" Motor
05407402	5 5/8" Motor

SLEEVE BEARING BRACKET KIT

- Ideal for replacing obsolete pillow blocks and streamlined bearings and can be used in some evaporative cooler applications.
- Completely assembled and ready to mount, fits most blowers from 9" to 16" sizes.
- Sintered bronze ball assembly assures maximum vibration absorption, quiet operation and constant self-alignment.

Part Number	Shaft Diameter	Maximum HP	Shaft Length
02917501*	3/4"	3/4 HP	20"
02917601	1"	1 HP	25"

*02917501 also replaces obsolete Part Number 38208201.

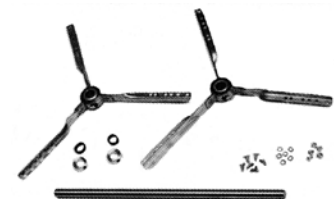

19.25" Overall Diameter

(Packaged in pairs with shaft and hardware group.)

Specifications are subject to change without notice or obligation

BLOWER PARTS & ACCESSORIES



Bearings

OIL SLEEVE BEARINGS

(Replaces Brundage)

Self-oiling with sintered bronze bushings and drive type oil cups.

Sleeve-type bearings require thrust collar kit.



Part No. / Pair*	Shaft Dia.	O.D.*
38269601	3/4"	2 ¹ / ₁₆ "
38269701	1"	2 ¹ / ₁₆ "

*O.D. as measured over rubber cushion.

CARTRIDGE TYPE SLEEVE BEARINGS

Designed to give you fast, easy interchangeability. It will fit any "spider type" bracket used on 9", 10" & 12" blowers.

Sintered bronze bushing pressed into steel bearing caps and cushioned in heavy neoprene conductive rubber.

Factory packed with lubricant for many years of quiet, trouble-free service. The Cartridge Bearing with a Journal may permit use of old shaft.

No thrust collar kit needed.



Cartridge Bearing with Journal

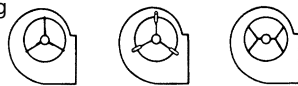

Types of "Spider" Brackets

Part No. / Pair*	Shaft Dia.	O.D.*
38209101 Mark IV	3/4" w/ thrust & spacer	1 ¹³ / ₁₆ "
38227201 Mark III	3/4" w/ journal	1 ¹³ / ₁₆ "
38209001	1"	1 ¹³ / ₁₆ "

*O.D. as measured over rubber cushion.

OIL TYPE - SLEEVE BEARINGS WITH INSULATOR

Self-aligning, self-oiling with sintered bronze bushings and drive type oil cups.

Sleeve-type bearings require thrust collar kit.



Part No. / Pair*	Shaft Dia.	O.D.*
38245001	3/4"	1 ²⁷ / ₃₂ "
38244901	1"	1 ²⁷ / ₃₂ "
38209401	1" Heavy Duty	2 ¹ / ₂ "

*O.D. as measured over rubber cushion.

Re-lubricate with SAE 20 or 30 weight oil. (Due to wicking, may need to oil at time of installation.)

+ All Bearings on this page shipped in pairs.

"LAU-PAK" - SLEEVE SEALED TYPE BEARINGS WITH INSULATOR

Factory packed with a supply of plastic petroleum assuring proper lubrication during the long life of the bearing.

Self-aligning, porous bronze sleeve pressed in housing.

Sleeve-type bearings require thrust collar kit.



Part No. / Pair*	Shaft Dia.	O.D.*
38244301	5/8"	1 ¹³ / ₁₆ "
38244302	3/4"	1 ¹³ / ₁₆ "
38244303	1"	2 ¹ / ₂ "

*O.D. as measured over rubber cushion.

"Lau Pack" and Oil Type may be used to replace bearings in blowers similar to those on Page 36

LAU OIL TYPE - SLEEVE BEARINGS WITH INSULATOR

Self-aligning, self-oiling, with bronze bushing held in housing under light, uniform spring presser, providing uniform distribution of lubricant through pores of bushing.

Drive type oil cup.

Sleeve-type bearings require thrust collar kit.



Part No. / Pair*	Shaft Dia.	O.D.*
38240401	5/8"	1 ¹³ / ₁₆ "
38244201	3/4"	1 ¹³ / ₁₆ "
38244202	1"	2 ¹ / ₂ "

*O.D. as measured over rubber cushion.

Shipped dry. Lubricate at time of installation with SAE 20 or 30 weight oil.

"Lau Pack" and Oil Type may be used to replace bearings in blowers similar to those on Page 36.

SEALED SLEEVE BEARINGS (Replaces Brundage)

Self-aligning, factory packed with a supply of plastic petroleum assuring proper lubrication during life of bearing.

Temperature Range for Sleeve Bearings: 40° - 135°.

Sleeve-type bearings require thrust collar kit.



Part No. / Pair*	Shaft Dia.	O.D.*
38269401	3/4"	2 ¹ / ₁₆ "
38269501	1"	2 ¹ / ₁₆ "

*O.D. as measured over rubber cushion.

For HP, RPM and Temperature Limits see chart on Page 58.

Specifications are subject to change without notice or obligation

Bearings

PILLOW BLOCK SLEEVE BEARINGS



Heavy neoprene cushion. Re-oilable porous bronze bushing in a pressed steel ball unit held firmly in a housing of two-piece interlocking steel.

This high quality self-aligning, static free, pillow block will assure quiet operation and many years of trouble-free performance.

Thrust collar kit required.

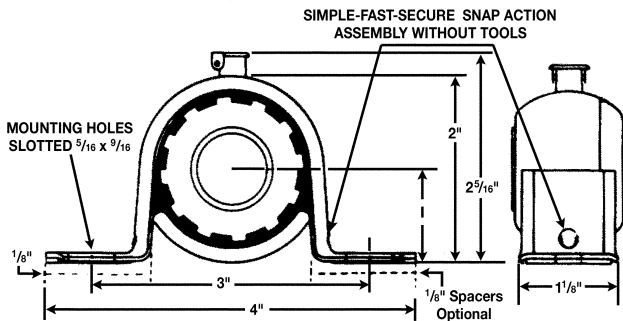

For use on Horizontal Shaft applications only

Part No. Per Pair*	Shaft Diameter
38220401	5/8"
38208601	3/4"
38208701	1"
38209301*	1" Heavy Duty

*Dimensions for the Heavy Duty Pillow Block are: Mounting Holes on Center 3 1/2"; Base to Shaft Center 1 1/8"; Width 1 1/2".

Two 1/8" rubber spacers provided for use, if needed.

PILLOW BLOCK BALL BEARINGS



Temperature Range: -30 to 200°F

- Durable cast-iron construction.
- Pre-lubricated bearings.
- Re-greasable.

Part No. Per Pair*	Shaft Dia.	Spread		Hole Size	O.D.*
		Min.	Max.		
38256701	3/4"	3 3/8"	3 7/8"	9/16" x 13/32"	3 5/16"
38256801	1"	3 7/8"	4 1/8"	9/16" x 13/32"	1 7/16"
38256901	1 1/16"	4 1/2"	4 3/4"	3/4" x 9/16"	1 11/16"
38257001	1 1/16"	4 3/4"	5"	3/4" x 9/16"	1 7/8"

*O.D. as measured over rubber cushion.

See instructions on self-locking collars on Page 58.

SEALED TYPE BALL BEARINGS WITH INSULATOR

For use when operating conditions exceed the limits of sleeve bearings or where repetitive failures occur. These bearings are pre-lubricated at the factory and require no further lubrication or attention. They are equipped with seals to retain grease better and to protect against contaminants.



Part No. Per Pair*	Temperature Range °F	Shaft Diameter	O.D.*
38258801	-20 +180	3/4" w/ interlocking thrust collar	1 13/16"
38259001	-20 +180	1" w/ interlocking thrust collar	2 17/32"
38256201	-20 +180	1 3/16" w/ interlocking thrust collar	2 7/32"

*O.D. as measured over rubber cushion.

Tighten locking collar in direction of rotation of shaft (see complete instructions on Page 58).

Sealed type ball bearings with insulator may be used on Lau Industrial blowers and other applications (see Page 36).

FLANGE BALL BEARINGS

Permanently sealed and lubricated with two-bolt flange unit. Rubber mounted with oil-resistant, rubber isolator inside stamped steel housing.



Part No. Per Pair*	Shaft Diameter	Spread	Hole Size	O.D.*
38256501	3/4"	3 3/8"	7/16"	2 41/64"
38256502	1"	3 3/8"	7/16"	2 41/64"

*O.D. as measured over rubber cushion.

TECHNICAL TIP: PILLOW BLOCK BALL BEARINGS ARE PRE-LUBRICATED FROM THE FACTORY. NORMAL OPERATING TEMPERATURE IS FROM -30°F TO 200°F. RE-LUBRICATION IS RECOMMENDED AT 6-12 MONTH INTERVALS UNDER NORMAL OPERATING CONDITIONS (CLEAN ENVIRONMENT AND UNDER 1500 RPM). WHEN RE-GREASING, TAKE CARE NOT TO OVER GREASE. OVER-GREASING CAN CAUSE SEAL BLOW OUT AND/OR BEARING BURNOUT.

BLOWER PARTS & ACCESSORIES



Bearings



Lau-Pak Sealed Sleeve Bearing



Sealed Ball Bearing



Cartridge Bearing



Oil Sleeve Bearing

Bearings	Bore Size	Temperature °F		Max. HP	Max. RPM
		Minimum	Maximum		
Sleeve Type	3/4"	+40	+135	3/4	1000
	1"	+40	+135	1	1000
Sealed Ball Bearings	3/4"	-20	+180	3	2200
	1"	-20	+180	7 1/2*	1900
	13/16"	-20	+180	7 1/2*	1900

* Over 3 HP motors use Heavy Duty 1-Piece Bearing Bracket found on Page 55.

HOW TO INSTALL A SELF-LOCKING COLLAR ON SEALED & PILLOW BLOCK BALL BEARINGS



1. Observe cam design of wide inner ring and self-locking collar.

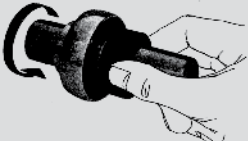

2. Mate cam of collar with cam of bearing inner ring.

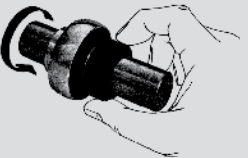

3. Pressing collar lightly against inner ring, turn collar in direction of shaft rotation until engaged.

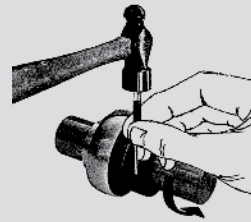

4. With drift pin in collar hole, strike in direction of shaft rotation to lock.

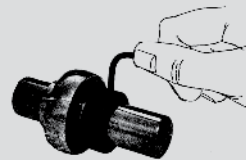

5. Tighten Setscrew in collar.

TECHNICAL TIP:

Below is the formula to determine the blower speed:

- You cannot bench test a blower at free air because it will most likely overload the motor.
- If you double the RPM of a fan or blower you would:
 - Get **twice** the CFM, **four** times the SP and require **eight** times the HP.
- When giving the dimensions of a wheel:
 - First** dimension should be diameter, **second** dimension stated should be width (Diameter x Width).
- Specifying Rotation:
 - Double Inlet Wheel = Viewing Hub Side
 - Single Inlet Wheel = Viewing Back Plate

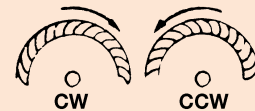

BLOWER RPM FORMULA

$$\frac{\text{Motor Pulley Diameter}}{\text{Blower Pulley Diameter}} \times \text{Motor RPM}$$

Specifications are subject to change without notice or obligation

Installation Parts

THRUST SLEEVE & SPACER KIT



Eliminates end play on sleeve bearing blowers. Replaces old style spring design.

Plastic sleeve with assortment of spacers adjusts to any size blower. Easy-to-follow instructions included. Only available in 3/4" shaft size.

Part No.	Per Pair*	Shaft Diameter
38220301		3/4"

THRUST COLLAR KIT



Sheet metal thrust collar in 3/4", 5/8" and 1" size. All with hollow head (Allen) setscrews.

Kit consists of one pair packaged with thrust washers. Order by part number.

Part No.	Per Pair*	Shaft Diameter
38243101*		5/8"
38220601		3/4"
38220701		1"

THRUST SPACER KIT



Packaged 12 per bag.

Part No.	Per Doz.	Shaft Diameter
38249101		5/8"
38249102		3/4"
38249103		1"

VIBRO-PADS - 5/16" HOLE



Resilient rubber pads snap easily into place. Reduces vibration, wear and noise on blowers, fans, motors, etc. (packaged 12 per bag). Order by part number.

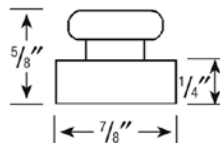

Part No.	Per Doz.
38220901	

MOTOR MOUNTING HARDWARE KIT

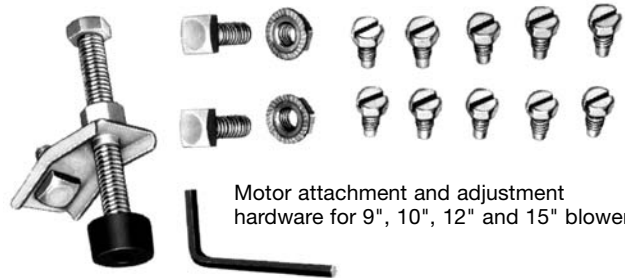

Motor attachment and adjustment hardware for 9", 10", 12" and 15" blowers.

Part No.	Per Doz.
38252101	

MOTOR ADJUSTMENT KIT

Tailpiece assembly for proper belt tension adjustment.

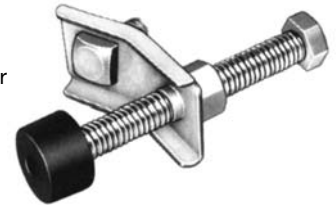

Part No.	Per Doz.
38252301	

MOTOR ADJUSTMENT GROMMETS

Resilient rubber tips for use with tailpiece assembly to reduce motor vibration and noise.



Part No.	Per Doz.
38252501	

Pack of 6.

SHAFTS

When a bearing fails, the shaft is inevitably scored. If not replaced, it will destroy the new bearings.



Premium shafting is ground and polished 1018 cold rolled steel. **Excess shaft may be cut off.** (Keyways and/or Flats are to be added as required in the field.)

Part No.	Diameter	Length	Shaft
38220501	5/8"	20"	Solid
38209601	3/4"	20"	Solid
38269301	3/4"	35"	Solid
38209501	1"	25"	Solid
38249201	1"	35"	Solid

+ THRUST SLEEVE & SPACER KIT AND THRUST COLLAR KIT ON THIS PAGE SHIPPED IN PAIRS.

When replacing bearings, be sure to replace the shaft.

TORQUE GUIDE CHART



Use for Lau Blower Wheels

DETERMINING MAXIMUM STARTING TORQUE BASED ON BORE SIZE

The hub bore size and type must be selected so that the starting torque experienced by the wheel does not exceed the maximum torque capability of the hub.

Based on the nominal motor horsepower selected for the application, calculate the fan starting torque at the hub by the following equation:

$$\text{Starting Torque (lb. ft.)} = \frac{\text{Motor Horsepower} \times 5252}{\text{Fan RPM}} \times Z$$

Arrangement	Direct Drive	Belt Drive		
	Shaded Perm. Split	Split Phase	Cap Start	Three Phase
Z=One wheel on shaft	0.6	1.4	2.2	3.0
Z=Two wheels on shaft	—	0.8	1.3	1.8
Z=Three wheels on shaft	—	0.6	0.9	1.2

After determining the lb./ft. starting torque, determine if you can use the standard wheels list this catalog.

TORQUE GUIDE CHART

Indicates Welded Hub

		Maximum Allowable Starting Torque Lb.- Ft.																
		Direct Drive				Belt Drive												
		DD		DD	"A" Belt Drive						"H" Welded Belt Drive							
Bore	Description	9	10	11	12	9	10	12	15	18	20	20	22	25	27	30	33	36
0.50	(1) Setscrew	8 →																
	(2) Setscrews	13 →																
0.62	(1) Setscrew			10 →														
	(2) Setscrews			16 →														
	(1) Setscrew w/KYWY			106 →														
0.75	(1) Setscrew					12.5 →												
	(2) Setscrews					20 →												
	(1) Setscrew w/KYWY					60 →		96 →										
1.00	(1) Setscrew					17 →												
	(2) Setscrews					26.5 →												
	(1) Setscrew w/KYWY					60 →		168 →										
1.19	(1) Setscrew					20 →												
	(2) Setscrews					31.5 →												
	(1) Setscrew w/KYWY					60 →		250 →				200 →						
1.44	(1) Setscrew					32 →												
	(2) Setscrews					50.5 →												
	(1) Setscrew w/KYWY					80 →		460 →					400					
1.69	(1) Setscrew							37.5 →										
	(2) Setscrews							60 →										
	(1) Setscrew w/KYWY								540 →				850					
1.94	(2) Setscrews										67.5 →							
	(1) Setscrew w/KYWY										870 →			1000				
2.19	(2) Setscrews										77 →							
	(1) Setscrew w/KYWY										980 →			1500				
2.44	(2) Setscrews										86 →							
	(1) Setscrew w/KYWY										1355 →			2000				
2.69	(2) Setscrews										95 →							
	(1) Setscrew w/KYWY										1495 →			2500				
2.25	Clamplok Hub												97					
3.00	Clamplok Hub												195					
4.00	Clamplok Hub												245					
4.50	Clamplok Hub												295					

Specifications are subject to change without notice or obligation

ABOUT GATES V-BELTS & PULLEYS

Gates is the world's largest manufacturer of power transmission belts for problem solving applications.

V-Belt Matching System

When it comes to choosing matched belts there is little room for error. For optimum performance, RMA (Rubber Manufacturers Association) specifications require matched belts up to 63" be within .15" in length. *That's the width of – a typical match head.*

This tiny fraction of an inch can make or break a belt drive. Matched belts that don't meet RMA standards won't evenly distribute the load, which can result in uneven belt and sheave wear, leading to premature failure.

The V80 belt matching system from Gates makes it easy to find matched belts. That's because all V80 belts meet and exceed RMA tolerance requirements. To ensure consistent belt lengths, Gates uses rigorous statistical process control (SPC) methods throughout their manufacturing process.

With Gates V-Belts, you'll get the most experienced engineering in the industry.

Flex-Bonded Cords

Gates Flex-Bonded Cords add strength to the belt. Flex-Bonded Cords are a strong chemical bond between the rubber body and tensile cord. The result is a belt that allows for absorption and bending stress without cord deterioration, and distributes the load equally.

Flex-Bonded Cords mean a long service life, making Gates Belts the cost-effective choice.

Light-Duty Pulleys

Gates light-duty pulleys are designed to use with Truflex® belts. The single or double-groove pulleys are precision machined and must be ordered separately.



V-BELTS & PULLEYS TABLE OF CONTENTS

General Information	61
Hi-Power® II, Heavy Duty Belts	
A Belts	62-63
B Belts	63-64
C Belts	65-66
D & E Belts	66
Power Curve® II, Heavy Duty Belt	
B Belts	67
Tri-Power®, Heavy Duty Belts	
AX Belts	68-69
BX Belts	69-70
CX Belts	70
Truflex®, Light Duty Belts	
2L Belts	71
3L Belts	72
4L Belts	73
5L Belts	74
Super HC®, Heavy Duty Belts	
3V Belts	75
5V Belts	76
8V Belts	76
Super HC® "Notched," Heavy Duty Belts	
3VX Belts	77
5VX Belts	78
One Groove Pulleys, Light Duty	
3L & 4L (Bored to Size)	79
4L & 5L (Bored to Size)	80
3L-4L & 5L (Variable Pitch)	83
3L & 4L (Taper Bushed)	84
4L & 5L (Taper Bushed)	85
Two Groove, Pulleys, Light Duty	
3L & 4L (Bored to Size)	81
4L & 5L (Bored to Size)	82
3L-4L & 5L (Variable Pitch)	83
3L & 4L (Taper Bushed)	86
4L & 5L (Taper Bushed)	86
Tension Testers	87

A BELTS

Hi-Power® II – Heavy Duty



Applications: Industrial where space, weight and horse power capacities are critical

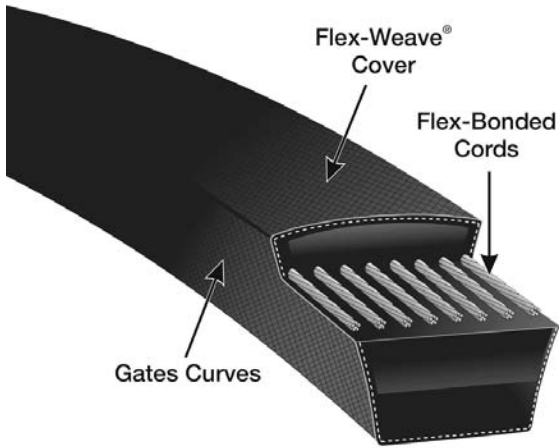

- **Composite, multi-purpose construction**
- **Resistant to oil, heat, ozone, sunlight, weather and aging**
- **Features Gates Curves, Flex-Bonded Cords and Flex-Weave® Cover**
- **Meets RMA oil and heat resistant standards**
- **Meets RMA static conductivity requirements**

Recommended Pulley: Multi-Duty

 **Gates Hi-Power® II belts are available in A, B, C, D and E cross sections.**

A BELTS – PART NUMBER SERIES: 9002

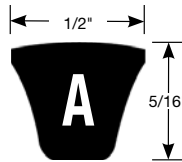

A24 - A46

Description	Part Number	Belt O.C.	Wt. (lbs.)
A24	G090022024	26	0.17
A25	G090022025	27	0.18
A26	G090022026	28	0.20
A27	G090022027	29	0.21
A28	G090022028	30	0.22
A29	G090022029	31	0.22
A29.8	G090022298	31.8	0.20
A30	G090022030	32	0.21
A31	G090022031	33	0.24
A32	G090022032	34	0.24
A33	G090022033	35	0.28
A34	G090022034	36	0.29
A35	G090022035	37	0.30
A36	G090022036	38	0.30
A37	G090022037	39	0.31
A38	G090022038	40	0.31
A39	G090022039	41	0.31
A40	G090022040	42	0.32
A41	G090022041	43	0.32
A42	G090022042	44	0.33
A43	G090022043	45	0.34
A44	G090022044	46	0.34
A45	G090022045	47	0.35
A46	G090022046	48	0.35

A47 - A70

Description	Part Number	Belt O.C.	Wt. (lbs.)
A47	G090022047	49	0.36
A48	G090022048	50	0.37
A49	G090022049	51	0.37
A50	G090022050	52	0.42
A51	G090022051	53	0.42
A52	G090022052	54	0.37
A53	G090022053	55	0.43
A54	G090022054	56	0.44
A55	G090022055	57	0.45
A56	G090022056	58	0.45
A57	G090022057	59	0.39
A58	G090022058	60	0.47
A59	G090022059	61	0.40
A60	G090022060	62	0.48
A61	G090022061	63	0.41
A62	G090022062	64	0.49
A63	G090022063	65	0.42
A64	G090022064	66	0.50
A65	G090022065	67	0.44
A66	G090022066	68	0.45
A67	G090022067	69	0.45
A68	G090022068	70	0.51
A69	G090022069	71	0.46
A70	G090022070	72	0.43

Specifications are subject to change without notice or obligation

A BELTS – PART NUMBER SERIES: 9002

A71 - A200

Description	Part Number	Belt O.C.	Wt. (lbs.)
A71	G090022071	73	0.44
A72	G090022072	74	0.48
A73	G090022073	75	0.45
A74	G090022074	76	0.46
A75	G090022075	77	0.46
A76	G090022076	78	0.47
A77	G090022077	79	0.48
A78	G090022078	80	0.48
A79	G090022079	81	0.49
A80	G090022080	82	0.54
A81	G090022081	83	0.50
A82	G090022082	84	0.51
A83	G090022083	85	0.51
A84	G090022084	86	0.52
A85	G090022085	87	0.57
A86	G090022086	88	0.60
A87	G090022087	89	0.58
A88	G090022088	90	0.54
A89	G090022089	91	0.60
A90	G090022090	92	0.60
A91	G090022091	93	0.61
A92	G090022092	94	0.61
A93	G090022093	95	0.57
A94	G090022094	96	0.63
A95	G090022095	97	0.59
A96	G090022096	98	0.63
A97	G090022097	99	0.66
A98	G090022098	100	0.60
A99	G090022099	101	0.70
A100	G090022100	102	0.62
A101	G090022101	103	0.71
A102	G090022102	104	0.72
A103	G090022103	105	0.63
A105	G090022105	107	0.65
A108	G090022108	110	0.76
A110	G090022110	112	0.73
A112	G090022112	114	0.74
A113	G090022113	115	0.79
A115	G090022115	117	0.71
A116	G090022116	118	0.81
A117	G090022117	119	0.82
A118	G090022118	120	0.83
A120	G090022120	122	0.74
A124	G090022124	126	0.85
A128	G090022128	130	0.87
A130	G090022130	132	0.90
A133	G090022133	135	0.87
A136	G090022136	138	0.89
A144	G090022144	146	0.95
A158	G090022158	160	1.04
A173	G090022173	175	1.13
A180	G090022180	182	1.29
A200	G090022200	202	1.42

B BELTS – PART NUMBER SERIES: 9003

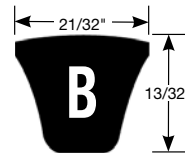

B28 - B75

Description	Part Number	Belt O.C.	Wt. (lbs.)
B28	G090032028	31	0.35
B29	G090032029	32	0.36
B30	G090032030	33	0.37
B31	G090032031	34	0.38
B32	G090032032	35	0.40
B33	G090032033	36	0.41
B34	G090032034	37	0.42
B35	G090032035	38	0.46
B36	G090032036	39	0.49
B37	G090032037	40	0.48
B38	G090032038	41	0.47
B39	G090032039	42	0.46
B40	G090032040	43	0.49
B41	G090032041	44	0.50
B42	G090032042	45	0.51
B43	G090032043	46	0.52
B44	G090032044	47	0.53
B45	G090032045	48	0.54
B46	G090032046	49	0.55
B47	G090032047	50	0.56
B48	G090032048	51	0.63
B49	G090032049	52	0.58
B50	G090032050	53	0.65
B51	G090032051	54	0.66
B52	G090032052	55	0.67
B53	G090032053	56	0.68
B54	G090032054	57	0.69
B55	G090032055	58	0.70
B56	G090032056	59	0.71
B57	G090032057	60	0.67
B58	G090032058	61	0.68
B59	G090032059	62	0.69
B60	G090032060	63	0.75
B61	G090032061	64	0.72
B62	G090032062	65	0.73
B63	G090032063	66	0.74
B64	G090032064	67	0.75
B65	G090032065	68	0.76
B66	G090032066	69	0.77
B67	G090032067	70	0.78
B68	G090032068	71	0.79
B69	G090032069	72	0.71
B70	G090032070	73	0.81
B71	G090032071	74	0.82
B72	G090032072	75	0.83
B73	G090032073	76	0.84
B74	G090032074	77	0.83
B75	G090032075	78	0.86

Specifications are subject to change without notice or obligation

B BELTS

Hi-Power® II – Heavy Duty



B BELTS – PART NUMBER SERIES: 9003

B76 - B127

Description	Part Number	Belt O.C.	Wt. (lbs.)
B76	G090032076	79	0.88
B77	G090032077	80	0.88
B78	G090032078	81	0.89
B79	G090032079	82	0.88
B80	G090032080	83	0.91
B81	G090032081	84	0.92
B82	G090032082	85	0.93
B83	G090032083	86	0.94
B84	G090032084	87	0.87
B85	G090032085	88	0.96
B86	G090032086	89	0.88
B87	G090032087	90	0.99
B88	G090032088	91	0.99
B89	G090032089	92	1.01
B90	G090032090	93	1.01
B91	G090032091	94	0.94
B92	G090032092	95	0.95
B93	G090032093	96	1.04
B94	G090032094	97	0.97
B95	G090032095	98	1.06
B96	G090032096	99	1.07
B97	G090032097	100	1.08
B98	G090032098	101	1.09
B99	G090032099	102	1.10
B100	G090032100	103	1.11
B101	G090032101	104	1.13
B102	G090032102	105	1.14
B103	G090032103	106	1.14
B104	G090032104	107	1.16
B105	G090032105	108	1.16
B106	G090032106	109	1.09
B108	G090032108	111	1.20
B109	G090032109	112	1.35
B110	G090032110	113	1.13
B111	G090032111	114	1.37
B112	G090032112	115	1.27
B113	G090032113	116	1.40
B114	G090032114	117	1.26
B115	G090032115	118	1.27
B116	G090032116	119	1.28
B117	G090032117	120	1.44
B118	G090032118	121	1.21
B120	G090032120	123	1.35
B122	G090032122	125	1.36
B123	G090032123	126	1.50
B124	G090032124	127	1.38
B125	G090032125	128	1.53
B126	G090032126	129	1.40
B127	G090032127	130	1.58

B128 - B340

Description	Part Number	Belt O.C.	Wt. (lbs.)
B128	G090032128	131	1.43
B130	G090032130	133	1.62
B131	G090032131	134	1.63
B132	G090032132	135	1.64
B133	G090032133	136	1.65
B135	G090032135	138	1.67
B136	G090032136	139	1.68
B137	G090032137	140	1.69
B138	G090032138	141	1.70
B140	G090032140	143	1.73
B142	G090032142	145	1.75
B144	G090032144	147	1.79
B146	G090032146	149	1.79
B147	G090032147	150	1.80
B148	G090032148	151	1.65
B150	G090032150	153	1.67
B152	G090032152	155	1.69
B153	G090032153	156	1.70
B154	G090032154	157	1.71
B156	G090032156	159	1.74
B158	G090032158	161	1.94
B160	G090032160	163	1.78
B164	G090032164	167	1.82
B166	G090032166	169	1.84
B168	G090032168	171	1.87
B173	G090032173	176	1.92
B174	G090032174	177	1.93
B175	G090032175	178	1.95
B180	G090032180	183	2.00
B185	G090032185	188	2.05
B188	G090032188	191	2.25
B190	G090032190	193	2.11
B192	G090032192	195	2.13
B195	G090032195	198	2.16
B199	G090032199	202	2.21
B200	G090032200	203	2.22
B205	G090032205	208	2.27
B210	G090032210	213	2.36
B225	G090032225	226	2.51
B240	G090032240	241	2.68
B255	G090032255	256	2.85
B270	G090032270	271	3.02
B285	G090032285	286	3.41
B292	G090032292	295	3.26
B300	G090032300	301	3.58
B315	G090032315	316	3.76
B330	G090032330	331	4.60
B340	G090032340	341	4.59

Specifications are subject to change without notice or obligation

C BELTS – PART NUMBER SERIES: 9004

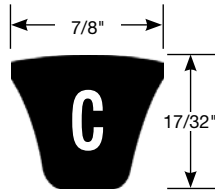

C44 - C97

Description	Part Number	Belt O.C.	Wt. (lbs.)
C44	G090042044	48	0.98
C46	G090042046	50	0.94
C48	G090042048	52	1.06
C50	G090042050	54	1.10
C51	G090042051	55	1.11
C52	G090042052	56	1.13
C53	G090042053	57	1.08
C54	G090042054	58	1.21
C55	G090042055	59	1.23
C56	G090042056	60	1.27
C57	G090042057	61	1.16
C58	G090042058	62	1.31
C59	G090042059	63	1.33
C60	G090042060	64	1.21
C61	G090042061	65	1.37
C62	G090042062	66	1.41
C63	G090042063	67	1.27
C65	G090042065	69	1.31
C66	G090042066	70	1.50
C67	G090042067	71	1.35
C68	G090042068	72	1.37
C69	G090042069	73	1.52
C70	G090042070	74	1.41
C71	G090042071	75	1.59
C72	G090042072	76	1.44
C73	G090042073	77	1.59
C74	G090042074	78	1.49
C75	G090042075	79	1.50
C76	G090042076	80	1.69
C78	G090042078	82	1.56
C79	G090042079	83	1.75
C80	G090042080	84	1.60
C81	G090042081	85	1.62
C82	G090042082	86	1.64
C83	G090042083	87	1.77
C84	G090042084	88	1.68
C85	G090042085	89	1.70
C86	G090042086	90	1.72
C87	G090042087	91	1.74
C88	G090042088	92	1.76
C90	G090042090	94	1.91
C91	G090042091	95	1.82
C92	G090042092	96	1.84
C93	G090042093	97	1.85
C94	G090042094	98	1.88
C95	G090042095	99	1.89
C96	G090042096	100	2.02
C97	G090042097	101	1.93

C98 - C168

Description	Part Number	Belt O.C.	Wt. (lbs.)
C98	G090042098	102	1.95
C99	G090042099	103	1.97
C100	G090042100	104	1.99
C101	G090042101	105	2.01
C102	G090042102	106	2.03
C103	G090042103	107	2.05
C104	G090042104	108	2.07
C105	G090042105	109	2.27
C106	G090042106	110	2.11
C107	G090042107	111	2.13
C108	G090042108	112	2.14
C109	G090042109	113	2.16
C110	G090042110	114	2.19
C111	G090042111	115	2.43
C112	G090042112	116	2.41
C115	G090042115	119	2.28
C116	G090042116	120	2.30
C118	G090042118	122	2.34
C120	G090042120	124	2.56
C122	G090042122	126	2.42
C124	G090042124	128	2.45
C126	G090042126	130	2.50
C128	G090042128	132	2.71
C130	G090042130	134	2.86
C131	G090042131	135	2.87
C134	G090042134	138	2.93
C135	G090042135	139	2.95
C136	G090042136	140	2.97
C137	G090042137	141	2.99
C138	G090042138	142	2.73
C140	G090042140	144	2.77
C142	G090042142	146	2.81
C143	G090042143	147	2.83
C144	G090042144	148	2.85
C146	G090042146	150	2.89
C147	G090042147	151	2.90
C148	G090042148	152	2.92
C150	G090042150	154	2.96
C151	G090042151	155	2.98
C153	G090042153	157	3.02
C154	G090042154	158	3.04
C155	G090042155	159	3.06
C156	G090042156	160	3.08
C158	G090042158	162	3.12
C162	G090042162	166	3.20
C164	G090042164	168	3.23
C165	G090042165	169	3.25
C168	G090042168	172	3.31

Specifications are subject to change without notice or obligation

C - D - E BELTS

Hi-Power® II – Heavy Duty



C BELTS – PART NUMBER SERIES: 9004



C170 - C420

Description	Part Number	Belt O.C.	Wt. (lbs.)
C170	G090042170	174	3.35
C173	G090042173	177	3.41
C175	G090042175	179	3.45
C180	G090042180	184	3.54
C183	G090042183	187	3.94
C185	G090042185	189	3.98
C190	G090042190	194	4.07
C195	G090042195	199	4.17
C202	G090042202	206	4.31
C204	G090042204	208	4.39
C207	G090042207	211	4.37
C210	G090042210	214	4.81
C220	G090042220	222	4.97
C225	G090042225	227	5.08
C240	G090042240	242	5.39
C245	G090042245	247	5.49
C255	G090042255	257	5.70
C270	G090042270	272	6.31
C285	G090042285	287	6.62
C300	G090042300	302	6.93
C315	G090042315	317	7.23
C330	G090042330	332	7.55
C345	G090042345	347	7.86
C360	G090042360	362	8.17
C390	G090042390	392	8.80
C420	G090042420	422	10.35

D BELTS – PART NUMBER SERIES: 9005

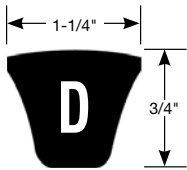

D105 - D240



Description	Part Number	Belt O.C.	Wt. (lbs.)
D105	G090052105	110	5.3
D112	G090052112	117	5.56
D120	G090052120	125	5.86
D128	G090052128	133	6.14
D136	G090052136	141	6.43
D144	G090052144	149	6.73
D158	G090052158	163	7.24
D162	G090052162	167	7.38
D167	G090052167	172	7.59
D173	G090052173	178	7.50
D180	G090052180	185	7.76
D195	G090052195	200	8.31
D210	G090052210	215	9.46
D225	G090052225	228	10.34
D240	G090052240	243	10.92

D BELTS – PART NUMBER SERIES: 9005

D255 - D660

Description	Part Number	Belt O.C.	Wt. (lbs.)
D255	G090052255	258	11.50
D270	G090052270	273	12.07
D285	G090052285	288	12.65
D300	G090052300	303	13.22
D315	G090052315	318	14.08
D330	G090052330	333	14.66
D345	G090052345	348	15.23
D360	G090052360	363	15.81
D390	G090052390	393	16.96
D420	G090052420	423	18.11
D450	G090052450	453	19.31
D480	G090052480	483	20.42
D540	G090052540	543	23.04
D600	G090052600	603	25.87
D660	G090052660	663	28.24

E BELTS – PART NUMBER SERIES: 9006

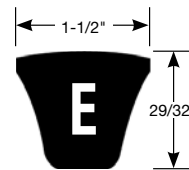

E180 - E660



Description	Part Number	Belt O.C.	Wt. (lbs.)
E180	G090062180	187	11.66
E195	G090062195	202	12.46
E210	G090062210	217	13.27
E240	G090062240	244	15.31
E270	G090062270	274	16.91
E300	G090062300	304	18.53
E330	G090062330	334	19.82
E360	G090062360	364	21.44
E390	G090062390	394	23.05
E420	G090062420	424	24.75
E480	G090062480	484	27.89
E540	G090062540	544	32.02
E600	G090062600	604	35.28
E660	G090062660	664	38.14



Gates Hi-Power belts are available in A, B, C, D and E cross sections.



SHIPPING NOTE:

Lau products can be shipped normal parcel shipping services, such as FedEx or UPS, but, some products are too large and must be shipped via common carrier.

Next Day or 2nd Day parcel services can be used to ship items at special handling costs. Because the majority of items in this catalog are bulky, we recommend checking with our Customer Service Representatives to verify the price of such expedited service.

Specifications are subject to change without notice or obligation

Applications: Power Turn Conveyor Belts & Automotive Mfg. Conveyors



- **Specifically engineered to handle the bending and twisting of conveyor applications**
- **Features a unique under cord construction and Flex-Weave® cover**
- **Meets RMA oil and heat resistant standards**

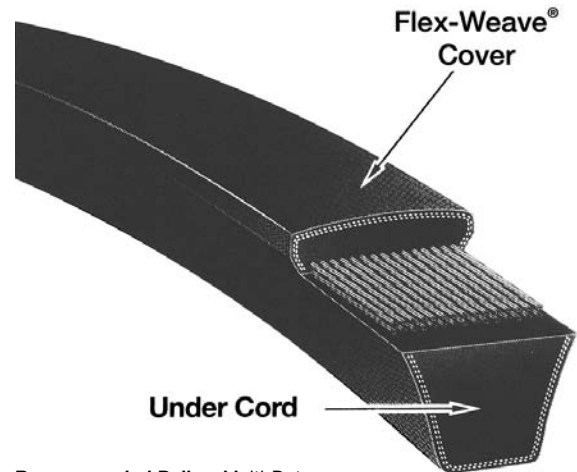

Recommended Pulley: Multi-Duty

Gates Power Curve® belts are available in B cross sections.

B BELTS – PART NUMBER SERIES: 9003



B112PC - B210PC

Description	Part Number	Belt O.C.	Wt. (lbs.)
B112PC	G090037112	1.39	115
B116PC	G090037116	1.32	119
B120PC	G090037120	1.37	123
B124PC	G090037124	1.41	127
B128PC	G090037128	1.62	131
B133PC	G090037133	1.68	136
B136PC	G090037136	1.72	139
B140PC	G090037140	1.76	143
B144PC	G090037144	1.64	147
B150PC	G090037150	1.70	153
B154PC	G090037154	1.75	157
B158PC	G090037158	1.80	161
B162PC	G090037162	1.84	165
B173PC	G090037173	1.96	176
B180PC	G090037180	2.04	183
B190PC	G090037190	2.15	193
B195PC	G090037195	2.21	198
B205PC	G090037205	2.32	208
B210PC	G090037210	2.38	213

B225PC - B500PC

Description	Part Number	Belt O.C.	Wt. (lbs.)
B225PC	G090037225	2.53	226
B240PC	G090037240	2.70	241
B255PC	G090037255	2.87	256
B270PC	G090037270	3.04	271
B285PC	G090037285	3.21	286
B300PC	G090037300	3.37	301
B315PC	G090037315	3.54	316
B330PC	G090037330	4.25	331
B345PC	G090037345	4.42	346
B360PC	G090037360	4.59	361
B375PC	G090037375	4.89	376
B390PC	G090037390	5.05	391
B405PC	G090037405	5.22	406
B420PC	G090037420	5.39	421
B430PC	G090037430	5.50	431
B445PC	G090037445	5.67	446
B460PC	G090037460	5.84	461
B500PC	G090037500	6.68	501



SHIPPING NOTE:

Most Lau products can be shipped normal parcel shipping services, such as FedEx or UPS, but, some products are too large and must be shipped via common carrier.

Next Day or 2nd Day parcel services can be used to ship items at special handling costs. Because the majority of items in this catalog are bulky, we recommend checking with our Customer Service Representatives to verify pricing of expedited service.

Specifications are subject to change without notice or obligation

AX BELTS

Tri-Power® – Heavy Duty



Applications: Industrial where small or sub-minimal pulley diameters are required

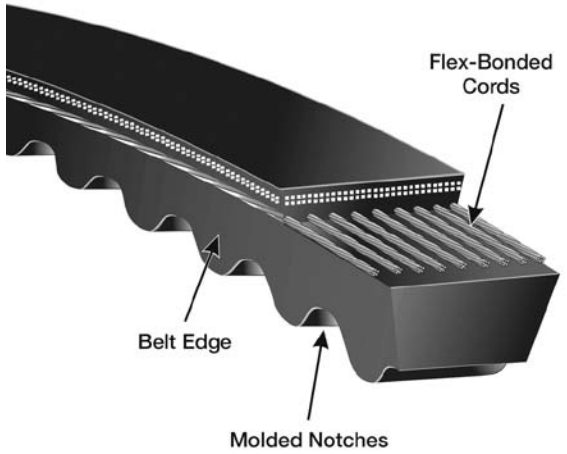

Recommended Pulley: Multi-Duty

 Gates Tri-Power® belts are available in AX, BX and CX sizes.

- Superior combination of flex and load carrying capacity, less stretching and less maintenance
- Features a special notch design and a machined belt edge
- New HMLS flex-bonded tensile cords and precision matched sidewalls
- Meets RMA oil and heat resistant standards
- Meets RMA static conductivity requirements

AX BELTS – PART NUMBER SERIES: 9012

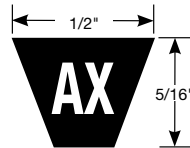

AX21 - AX46

Description	Part Number	Belt O.C.	Wt. (lbs.)
AX21	G090122021	23	0.15
AX22	G090122022	24	0.16
AX23	G090122023	25	0.16
AX24	G090122024	26	0.17
AX25	G090122025	27	0.17
AX26	G090122026	28	0.19
AX27	G090122027	29	0.19
AX28	G090122028	30	0.20
AX29	G090122029	31	0.20
AX30	G090122030	32	0.23
AX31	G090122031	33	0.23
AX32	G090122032	34	0.25
AX33	G090122033	35	0.27
AX34	G090122034	36	0.27
AX35	G090122035	37	0.28
AX36	G090122036	38	0.28
AX37	G090122037	39	0.29
AX38	G090122038	40	0.30
AX39	G090122039	41	0.30
AX40	G090122040	42	0.30
AX41	G090122041	43	0.32
AX42	G090122042	44	0.32
AX43	G090122043	45	0.33
AX44	G090122044	46	0.33
AX45	G090122045	47	0.33
AX46	G090122046	48	0.34

AX47 - A72

Description	Part Number	Belt O.C.	Wt. (lbs.)
AX47	G090122047	49	0.34
AX48	G090122048	50	0.35
AX49	G090122049	51	0.35
AX50	G090122050	52	0.36
AX51	G090122051	53	0.36
AX52	G090122052	54	0.36
AX53	G090122053	55	0.37
AX54	G090122054	56	0.37
AX55	G090122055	57	0.37
AX56	G090122056	58	0.38
AX57	G090122057	59	0.38
AX58	G090122058	60	0.39
AX59	G090122059	61	0.40
AX60	G090122060	62	0.40
AX61	G090122061	63	0.41
AX62	G090122062	64	0.41
AX63	G090122063	65	0.42
AX64	G090122064	66	0.42
AX65	G090122065	67	0.43
AX66	G090122066	68	0.44
AX67	G090122067	69	0.44
AX68	G090122068	70	0.45
AX69	G090122069	71	0.45
AX70	G090122070	72	0.46
AX71	G090122071	73	0.46
AX72	G090122072	74	0.47

Specifications are subject to change without notice or obligation

AX BELTS – PART NUMBER SERIES: 9012

AX73 - AX88

Description	Part Number	Belt O.C.	Wt. (lbs.)
AX73	G090122073	75	0.48
AX74	G090122074	76	0.48
AX75	G090122075	77	0.49
AX76	G090122076	78	0.49
AX77	G090122077	79	0.49
AX78	G090122078	80	0.50
AX79	G090122079	81	0.51
AX80	G090122080	82	0.52
AX81	G090122081	83	0.52
AX82	G090122082	84	0.53
AX83	G090122083	85	0.53
AX84	G090122084	86	0.53
AX85	G090122085	87	0.54
AX86	G090122086	88	0.55
AX87	G090122087	89	0.56
AX88	G090122088	90	0.56

AX BELTS – PART NUMBER SERIES: 9012

AX89 - AX173

Description	Part Number	Belt O.C.	Wt. (lbs.)
AX89	G090122089	91	0.56
AX90	G090122090	92	0.57
AX91	G090122091	93	0.57
AX92	G090122092	94	0.57
AX93	G090122093	95	0.58
AX94	G090122094	96	0.59
AX96	G090122096	98	0.60
AX97	G090122097	99	0.61
AX98	G090122098	100	0.62
AX103	G090122103	105	0.64
AX105	G090122105	107	0.64
AX110	G090122110	112	0.68
AX112	G090122112	114	0.70
AX120	G090122120	122	0.74
AX128	G090122128	130	0.79
AX144	G090122144	146	0.91
AX173	G090122173	175	1.13

BX BELTS – PART NUMBER SERIES: 9013

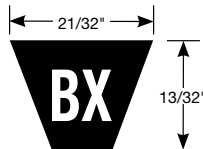

BX24 - BX49

Description	Part Number	Belt O.C.	Wt. (lbs.)
BX24	G090132024	27	0.30
BX25	G090132025	28	0.31
BX26	G090132026	29	0.32
BX27	G090132027	30	0.33
BX28	G090132028	31	0.34
BX29	G090132029	32	0.35
BX30	G090132030	33	0.35
BX31	G090132031	34	0.35
BX32	G090132032	35	0.36
BX33	G090132033	36	0.37
BX34	G090132034	37	0.38
BX35	G090132035	38	0.39
BX36	G090132036	39	0.40
BX37	G090132037	40	0.43
BX38	G090132038	41	0.45
BX39	G090132039	42	0.47
BX40	G090132040	43	0.47
BX41	G090132041	44	0.47
BX42	G090132042	45	0.50
BX43	G090132043	46	0.51
BX44	G090132044	47	0.52
BX45	G090132045	48	0.53
BX46	G090132046	49	0.53
BX47	G090132047	50	0.53
BX48	G090132048	51	0.54
BX49	G090132049	52	0.55

BX50 - BX75

Description	Part Number	Belt O.C.	Wt. (lbs.)
BX50	G090132050	53	0.64
BX51	G090132051	54	0.65
BX52	G090132052	55	0.66
BX53	G090132053	56	0.67
BX54	G090132054	57	0.63
BX55	G090132055	58	0.69
BX56	G090132056	59	0.69
BX57	G090132057	60	0.70
BX58	G090132058	61	0.71
BX59	G090132059	62	0.73
BX60	G090132060	63	0.74
BX61	G090132061	64	0.75
BX62	G090132062	65	0.76
BX63	G090132063	66	0.77
BX64	G090132064	67	0.78
BX65	G090132065	68	0.79
BX66	G090132066	69	0.80
BX67	G090132067	70	0.77
BX68	G090132068	71	0.78
BX69	G090132069	72	0.79
BX70	G090132070	73	0.80
BX71	G090132071	74	0.81
BX72	G090132072	75	0.82
BX73	G090132073	76	0.83
BX74	G090132074	77	0.84
BX75	G090132075	78	0.84

Specifications are subject to change without notice or obligation

BX & CX BELTS

Tri-Power® - Heavy Duty



BX BELTS – PART NUMBER SERIES: 9013

BX76 - BX105

Description	Part Number	Belt O.C.	Wt. (lbs.)
BX76	G090132076	79	0.85
BX77	G090132077	80	0.86
BX78	G090132078	81	0.87
BX79	G090132079	82	0.88
BX80	G090132080	83	0.89
BX81	G090132081	84	0.90
BX82	G090132082	85	0.91
BX83	G090132083	86	0.92
BX84	G090132084	87	0.93
BX85	G090132085	88	0.94
BX86	G090132086	89	0.95
BX87	G090132087	90	0.96
BX88	G090132088	91	0.97
BX89	G090132089	92	0.98
BX90	G090132090	93	0.99
BX91	G090132091	94	1.00
BX92	G090132092	95	1.01
BX93	G090132093	96	1.01
BX94	G090132094	97	1.02
BX95	G090132095	98	1.03
BX96	G090132096	99	1.04
BX97	G090132097	100	1.05
BX98	G090132098	101	1.06
BX99	G090132099	102	1.07
BX100	G090132100	103	1.08
BX103	G090132103	106	1.11
BX105	G090132105	108	1.14

BX BELTS – PART NUMBER SERIES: 9013

BX106 - BX300

Description	Part Number	Belt O.C.	Wt. (lbs.)
BX106	G090132106	109	1.17
BX108	G090132108	111	1.18
BX110	G090132110	113	1.20
BX112	G090132112	115	1.24
BX113	G090132113	116	1.24
BX115	G090132115	118	1.25
BX116	G090132116	119	1.27
BX120	G090132120	123	1.30
BX124	G090132124	127	1.35
BX128	G090132128	131	1.38
BX133	G090132133	136	1.38
BX136	G090132136	139	1.42
BX140	G090132140	143	1.42
BX144	G090132144	147	1.46
BX150	G090132150	153	1.48
BX158	G090132158	161	1.56
BX162	G090132162	165	1.60
BX173	G090132173	176	1.71
BX180	G090132180	183	1.77
BX195	G090132195	198	1.92
BX205	G090132205	208	2.31
BX210	G090132210	213	2.51
BX225	G090132225	227	2.74
BX255	G090132255	257	2.85
BX270	G090132270	272	3.02
BX300	G090132300	302	4.02

CX BELTS – PART NUMBER SERIES: 9014

CX51 - CX133

Description	Part Number	Belt O.C.	Wt. (lbs.)
CX51	G090142051	55	1.02
CX60	G090142060	64	1.07
CX68	G090142068	72	1.29
CX75	G090142075	79	1.35
CX81	G090142081	85	1.41
CX85	G090142085	89	1.47
CX90	G090142090	94	1.55
CX96	G090142096	100	1.65
CX100	G090142100	104	1.72
CX101	G090142101	105	1.74
CX105	G090142105	109	1.80
CX106	G090142106	110	1.82
CX109	G090142109	113	1.87
CX112	G090142112	116	1.92
CX115	G090142115	119	1.97
CX120	G090142120	124	2.07
CX123	G090142123	127	2.10
CX128	G090142128	132	2.18
CX133	G090142133	137	2.26

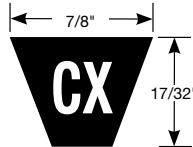

CX136 - CX-360

Description	Part Number	Belt O.C.	Wt. (lbs.)
CX136	G090142136	140	2.31
CX144	G090142144	148	2.44
CX150	G090142150	154	2.56
CX158	G090142158	162	2.67
CX162	G090142162	166	2.74
CX173	G090142173	177	2.92
CX180	G090142180	184	3.04
CX187	G090142187	191	3.15
CX190	G090142190	194	3.20
CX195	G090142195	199	3.29
CX210	G090142210	214	3.53
CX225	G090142225	227	5.33
CX240	G090142240	242	5.64
CX255	G090142255	257	5.95
CX270	G090142270	272	6.26
CX300	G090142300	302	6.88
CX330	G090142330	332	6.90
CX360	G090142360	362	8.55



Specifications are subject to change without notice or obligation

Applications: Light Duty and Lower HP



- Superior length stability for minimal take-up requirements
- Features Gates Curves, Flex-Bonded Cords and Flex-Weave® Cover
- Thin profile for small diameter drives
- Meets RMA oil and heat resistant standards
- Meets RMA static conductivity requirements

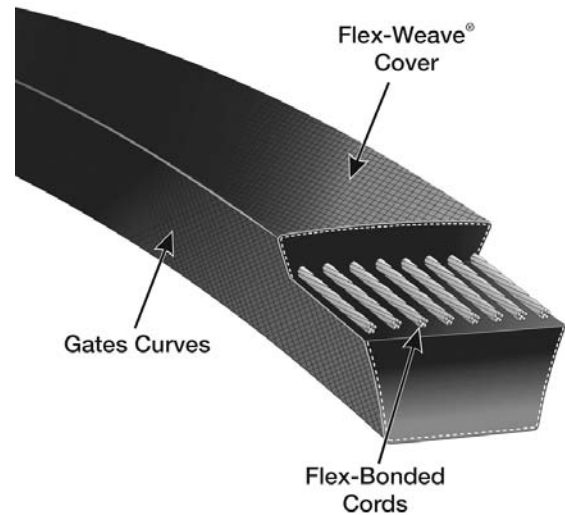

Truflex® belts are available in 2L, 3L, 4L and 5L cross sections.

RECOMMENDED PULLEYS:
 Light-Duty Pulleys-Bored-to-Size
 Light-Duty Pulleys-Variable Pitch
 Light-Duty Pulleys-Bushed

2L BELTS – PART NUMBER SERIES: 8400

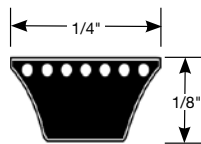

2L100 - 2L210

Description	Part Number	Belt O.C.	Wt. (lbs.)
2L100	G084000100	10	0.02
2L110	G084000110	11	0.02
2L120	G084000120	12	0.02
2L130	G084000130	13	0.03
2L140	G084000140	14	0.03
2L150	G084000150	15	0.03
2L160	G084000160	16	0.03
2L170	G084000170	17	0.03
2L180	G084000180	18	0.03
2L190	G084000190	19	0.03
2L200	G084000200	20	0.04
2L210	G084000210	21	0.04

2L230 - 2L460

Description	Part Number	Belt O.C.	Wt. (lbs.)
2L230	G084000230	23	0.04
2L240	G084000240	24	0.04
2L250	G084000250	25	0.04
2L260	G084000260	26	0.04
2L270	G084000270	27	0.04
2L280	G084000280	28	0.05
2L290	G084000290	29	0.05
2L310	G084000310	31	0.05
2L340	G084000340	34	0.06
2L350	G084000350	35	0.06
2L360	G084000360	36	0.06
2L380	G084000380	38	0.06
2L460	G084000460	46	0.07



SHIPPING NOTE:

Most Lau products can be shipped normal parcel shipping services, such as FedEx or UPS, but, some products are too large and must be shipped via common carrier.

Next Day or 2nd Day parcel services can be used to ship items at special handling costs. Because the majority of items in this catalog are bulky, we recommend checking with our Customer Service Representatives to verify pricing of expedited service.

Specifications are subject to change without notice or obligation

3L BELTS – PART NUMBER SERIES: 8400

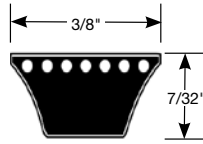

3L110 - 3L390

Description	Part Number	Belt O.C.	Wt. (lbs.)
3L110	G084001110	11	0.04
3L120	G084001120	12	0.05
3L130	G084001130	13	0.05
3L140	G084001140	14	0.05
3L150	G084001150	15	0.06
3L160	G084001160	16	0.06
3L170	G084001170	17	0.07
3L180	G084001180	18	0.07
3L190	G084001190	19	0.07
3L200	G084001200	20	0.07
3L210	G084001210	21	0.08
3L220	G084001220	22	0.08
3L230	G084001230	23	0.08
3L240	G084001240	24	0.08
3L245	G084001245	24.5	0.09
3L250	G084001250	25	0.09
3L255	G084001255	25.5	0.09
3L260	G084001260	26	0.09
3L265	G084001265	26.5	0.09
3L270	G084001270	27	0.09
3L275	G084001275	27.5	0.10
3L280	G084001280	28	0.10
3L285	G084001285	28.5	0.10
3L290	G084001290	29	0.10
3L293	G084001293	29.3	0.10
3L300	G084001300	30	0.10
3L310	G084001310	31	0.11
3L320	G084001320	32	0.11
3L330	G084001330	33	0.11
3L340	G084001340	34	0.12
3L345	G084001345	34.5	0.12
3L350	G084001350	35	0.12
3L360	G084001360	36	0.13
3L370	G084001370	37	0.14
3L380	G084001380	38	0.14
3L390	G084001390	39	0.14

3L400 - 3L740

Description	Part Number	Belt O.C.	Wt. (lbs.)
3L400	G084001400	40	0.14
3L410	G084001410	41	0.15
3L415	G084001415	41.5	0.15
3L420	G084001420	42	0.15
3L430	G084001430	43	0.16
3L440	G084001440	44	0.16
3L450	G084001450	45	0.16
3L460	G084001460	46	0.17
3L470	G084001470	47	0.17
3L480	G084001480	48	0.17
3L490	G084001490	49	0.18
3L500	G084001500	50	0.18
3L510	G084001510	51	0.18
3L520	G084001520	52	0.18
3L530	G084001530	53	0.19
3L540	G084001540	54	0.19
3L550	G084001550	55	0.19
3L560	G084001560	56	0.19
3L570	G084001570	57	0.20
3L580	G084001580	58	0.20
3L590	G084001590	59	0.20
3L600	G084001600	60	0.21
3L610	G084001610	61	0.21
3L620	G084001620	62	0.21
3L630	G084001630	63	0.22
3L640	G084001640	64	0.22
3L650	G084001650	65	0.22
3L660	G084001660	66	0.23
3L670	G084001670	67	0.23
3L675	G084001675	67.5	0.23
3L680	G084001680	68	0.23
3L690	G084001690	69	0.23
3L700	G084001700	70	0.23
3L710	G084001710	71	0.23
3L730	G084001730	73	0.24
3L740	G084001740	74	0.26



SHIPPING NOTE:

Most Lau products can be shipped normal parcel shipping services, such as FedEx or UPS, but, some products are too large and must be shipped via common carrier.

Next Day or 2nd Day parcel services can be used to ship items at special handling costs. Because the majority of items in this catalog are bulky, we recommend checking with our Customer Service Representatives to verify pricing of expedited service.

Specifications are subject to change without notice or obligation

4L BELTS – PART NUMBER SERIES: 8400

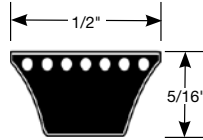

4L150 - 4L500

Description	Part Number	Belt O.C.	Wt. (lbs.)
4L150	G084002150	15.0	0.08
4L160	G084002160	16.0	0.09
4L170	G084002170	17.0	0.10
4L180	G084002180	18.0	0.10
4L188	G084002188	18.8	0.11
4L190	G084002190	19.0	0.11
4L200	G084002200	20.0	0.11
4L210	G084002210	21.0	0.11
4L215	G084002215	21.5	0.12
4L220	G084002220	22.0	0.12
4L230	G084002230	23.0	0.13
4L235	G084002235	23.5	0.13
4L240	G084002240	24.0	0.13
4L250	G084002250	25.0	0.14
4L255	G084002255	25.5	0.14
4L260	G084002260	26.0	0.14
4L270	G084002270	27.0	0.15
4L275	G084002275	27.5	0.15
4L280	G084002280	28.0	0.15
4L285	G084002285	28.5	0.16
4L290	G084002290	29.0	0.16
4L295	G084002295	29.5	0.17
4L300	G084002300	30.0	0.17
4L310	G084002310	31.0	0.17
4L318	G084002318	31.8	0.18
4L320	G084002320	32.0	0.18
4L328	G084002328	32.8	0.18
4L330	G084002330	33.0	0.18
4L333	G084002333	33.3	0.19
4L338	G084002338	33.8	0.19
4L340	G084002340	34.0	0.18
4L346	G084002346	34.5	0.19
4L350	G084002350	35.0	0.19
4L360	G084002360	36.0	0.20
4L370	G084002370	37.0	0.20
4L380	G084002380	38.0	0.21
4L390	G084002390	39.0	0.21
4L400	G084002400	40.0	0.23
4L405	G084002405	40.5	0.24
4L410	G084002410	41.0	0.24
4L420	G084002420	42.0	0.24
4L430	G084002430	43.0	0.24
4L440	G084002440	44.0	0.25
4L450	G084002450	45.0	0.25
4L460	G084002460	46.0	0.26
4L470	G084002470	47.0	0.26
4L475	G084002475	47.5	0.27
4L480	G084002480	48.0	0.27
4L490	G084002490	49.0	0.27
4L500	G084002500	50.0	0.28

4L510 - 4L1000

Description	Part Number	Belt O.C.	Wt. (lbs.)
4L510	G084002510	51	0.28
4L520	G084002520	52	0.28
4L530	G084002530	53	0.29
4L540	G084002540	54	0.29
4L550	G084002550	55	0.30
4L560	G084002560	56	0.30
4L570	G084002570	57	0.31
4L580	G084002580	58	0.31
4L590	G084002590	59	0.32
4L600	G084002600	60	0.32
4L610	G084002610	61	0.33
4L620	G084002620	62	0.34
4L630	G084002630	63	0.34
4L640	G084002640	64	0.35
4L650	G084002650	65	0.36
4L660	G084002660	66	0.36
4L670	G084002670	67	0.37
4L680	G084002680	68	0.37
4L690	G084002690	69	0.37
4L700	G084002700	70	0.38
4L710	G084002710	71	0.38
4L720	G084002720	72	0.42
4L730	G084002730	73	0.42
4L740	G084002740	74	0.43
4L750	G084002750	75	0.43
4L760	G084002760	76	0.43
4L770	G084002770	77	0.43
4L780	G084002780	78	0.43
4L790	G084002790	79	0.43
4L800	G084002800	80	0.44
4L810	G084002810	81	0.45
4L820	G084002820	82	0.45
4L830	G084002830	83	0.46
4L840	G084002840	84	0.47
4L850	G084002850	85	0.47
4L860	G084002860	86	0.47
4L870	G084002870	87	0.48
4L880	G084002880	88	0.50
4L890	G084002890	89	0.50
4L900	G084002900	90	0.51
4L910	G084002910	91	0.51
4L920	G084002920	92	0.52
4L930	G084002930	93	0.52
4L940	G084002940	94	0.52
4L950	G084002950	95	0.53
4L960	G084002960	96	0.54
4L970	G084002970	97	0.54
4L980	G084002980	98	0.55
4L990	G084002990	99	0.55
4L1000	G084002100	100	0.56

Specifications are subject to change without notice or obligation

5L BELTS – PART NUMBER SERIES: 8400

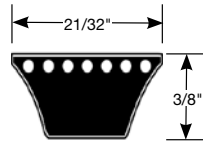

5L230 - 5L600

Description	Part Number	Belt O.C.	Wt. (lbs.)
5L230	G084003230	23	0.21
5L240	G084003240	24	0.22
5L250	G084003250	25	0.22
5L260	G084003260	26	0.23
5L265	G084003265	26.5	0.24
5L270	G084003270	27	0.24
5L280	G084003280	28	0.26
5L290	G084003290	29	0.26
5L300	G084003300	30	0.27
5L310	G084003310	31	0.28
5L320	G084003320	32	0.30
5L330	G084003330	33	0.30
5L340	G084003340	34	0.31
5L350	G084003350	35	0.32
5L355	G084003355	35.5	0.32
5L360	G084003360	36	0.33
5L370	G084003370	37	0.34
5L380	G084003380	38	0.35
5L390	G084003390	39	0.35
5L400	G084003400	40	0.36
5L410	G084003410	41	0.38
5L420	G084003420	42	0.38
5L430	G084003430	43	0.39
5L440	G084003440	44	0.40
5L450	G084003450	45	0.41
5L460	G084003460	46	0.42
5L470	G084003470	47	0.43
5L480	G084003480	48	0.43
5L490	G084003490	49	0.44
5L500	G084003500	50	0.45
5L510	G084003510	51	0.47
5L520	G084003520	52	0.47
5L530	G084003530	53	0.47
5L540	G084003540	54	0.48
5L550	G084003550	55	0.49
5L560	G084003560	56	0.50
5L570	G084003570	57	0.50
5L580	G084003580	58	0.51
5L590	G084003590	59	0.52
5L600	G084003600	60	0.53

L610 - 5L1000

Description	Part Number	Belt O.C.	Wt. (lbs.)
5L610	G084003610	61	0.54
5L620	G084003620	62	0.55
5L630	G084003630	63	0.56
5L640	G084003640	64	0.61
5L650	G084003650	65	0.61
5L660	G084003660	66	0.62
5L670	G084003670	67	0.63
5L680	G084003680	68	0.63
5L690	G084003690	69	0.63
5L700	G084003700	70	0.63
5L710	G084003710	71	0.66
5L720	G084003720	72	0.67
5L730	G084003730	73	0.68
5L740	G084003740	74	0.68
5L750	G084003750	75	0.68
5L760	G084003760	76	0.68
5L770	G084003770	77	0.69
5L780	G084003780	78	0.69
5L790	G084003790	79	0.72
5L800	G084003800	80	0.72
5L810	G084003810	81	0.72
5L820	G084003820	82	0.73
5L830	G084003830	83	0.73
5L840	G084003840	84	0.76
5L850	G084003850	85	0.77
5L860	G084003860	86	0.78
5L870	G084003870	87	0.79
5L880	G084003880	88	0.80
5L890	G084003890	89	0.81
5L900	G084003900	90	0.81
5L910	G084003910	91	0.82
5L920	G084003920	92	0.83
5L930	G084003930	93	0.83
5L940	G084003940	94	0.84
5L950	G084003950	95	0.85
5L960	G084003960	96	0.85
5L970	G084003970	97	0.86
5L980	G084003980	98	0.87
5L990	G084003990	99	0.88
5L1000	G084003100	100	0.89



SHIPPING NOTE:

Most Lau products can be shipped normal parcel shipping services, such as FedEx or UPS, but, some products are too large and must be shipped via common carrier.

Next Day or 2nd Day parcel services can be used to ship items at special handling costs. Because the majority of items in this catalog are bulky, we recommend checking with our Customer Service Representatives to verify pricing of expedited service.

Specifications are subject to change without notice or obligation



Applications: Industrial where space, weight and HP are critical

- **Light weight, competitively priced, ideal to transmit high HP wherever high speed ratios or small pulley diameters are required**
- **Features Gates Curves, Flex-Bonded Cords and Flex-Weave® Cover**
- **Meets RMA oil and heat resistant standards**
- **Meets RMA static conductivity requirements**

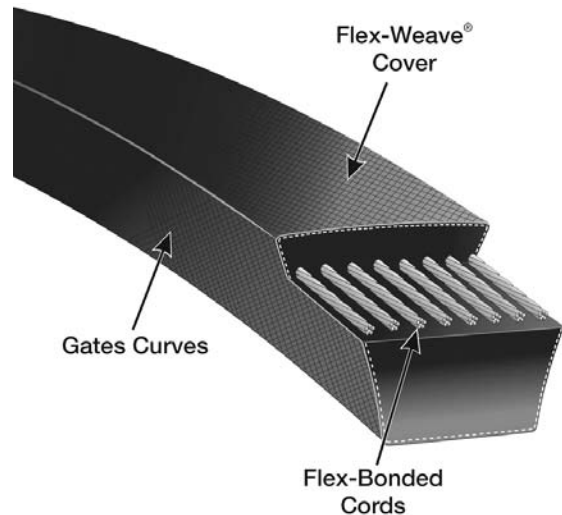

 **Gates Super HC® belts are available in 3V, 5V, and 8V cross sections.**

RECOMMENDED PULLEY: Super HC

3V BELTS – PART NUMBER SERIES: 9332

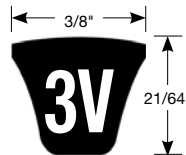

3V250 - 3V600

Description	Part Number	Belt O.C.	Wt. (lbs.)
3V250	G093320250	25.0	0.13
3V265	G093320265	26.5	0.14
3V280	G093320280	28.0	0.15
3V300	G093320300	30.0	0.16
3V315	G093320315	31.5	0.16
3V335	G093320335	33.5	0.16
3V355	G093320355	35.5	0.17
3V375	G093320375	37.5	0.18
3V400	G093320400	40.0	0.19
3V425	G093320425	42.5	0.20
3V450	G093320450	45.0	0.22
3V475	G093320475	47.5	0.21
3V500	G093320500	50.0	0.29
3V530	G093320530	53.0	0.30
3V560	G093320560	56.0	0.32
3V600	G093320600	60.0	0.37

3V630 - 3V1400

Description	Part Number	Belt O.C.	Wt. (lbs.)
3V630	G093320630	63.0	0.37
3V670	G093320670	67.0	0.37
3V710	G093320710	71.0	0.39
3V750	G093320750	75.0	0.40
3V800	G093320800	80.0	0.43
3V850	G093320850	85.0	0.45
3V900	G093320900	90.0	0.47
3V950	G093320950	95.0	0.48
3V1000	G093321000	100.0	0.52
3V1060	G093321060	106.0	0.53
3V1120	G093321120	112.0	0.56
3V1180	G093321180	118.0	0.56
3V1250	G093321250	125.0	0.56
3V1320	G093321320	132.0	0.60
3V1400	G093321400	140.0	0.64



SHIPPING NOTE:

Most Lau products can be shipped normal parcel shipping services, such as FedEx or UPS, but, some products are too large and must be shipped via common carrier.

Next Day or 2nd Day parcel services can be used to ship items at special handling costs. Because the majority of items in this catalog are bulky, we recommend checking with our Customer Service Representatives to verify pricing of expedited service.

Specifications are subject to change without notice or obligation

5V & 8V BELTS

Super HC® – Heavy Duty



5V BELTS – PART NUMBER SERIES: 9334

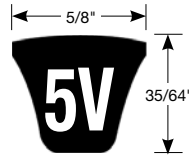

5V500 - 5V1320

Description	Part Number	Belt O.C.	Wt. (lbs.)
5V500	G093340500	50	0.64
5V530	G093340530	53	0.69
5V560	G093340560	56	0.73
5V600	G093340600	60	0.78
5V630	G093340630	63	0.87
5V670	G093340670	67	0.87
5V710	G093340710	71	0.92
5V750	G093340750	75	0.97
5V800	G093340800	80	1.14
5V850	G093340850	85	1.21
5V900	G093340900	90	1.27
5V950	G093340950	95	1.34
5V1000	G093341000	100	1.41
5V1060	G093341060	106	1.51
5V1120	G093341120	112	1.58
5V1180	G093341180	118	1.66
5V1250	G093341250	125	1.76
5V1320	G093341320	132	1.94

5V1400 - 5V3550

Description	Part Number	Belt O.C.	Wt. (lbs.)
5V1400	G093341400	140	2.01
5V1500	G093341500	150	2.14
5V1600	G093341600	160	2.27
5V1700	G093341700	170	2.40
5V1800	G093341800	180	2.68
5V1900	G093341900	190	2.81
5V2000	G093342000	200	2.94
5V2120	G093342120	212	3.15
5V2240	G093342240	224	3.26
5V2360	G093342360	236	3.47
5V2500	G093342500	250	3.32
5V2650	G093342650	265	3.52
5V2800	G093342800	280	4.05
5V3000	G093343000	300	3.98
5V3150	G093343150	315	4.20
5V3350	G093343350	335	4.46
5V3550	G093343550	355	4.73

8V BELTS – PART NUMBER SERIES: 9336

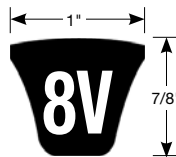

8V1000 - 8V2240

Description	Part Number	Belt O.C.	Wt. (lbs.)
8V1000	G093361000	100	3.35
8V1060	G093361060	106	3.56
8V1120	G093361120	112	4.18
8V1180	G093361180	118	4.39
8V1250	G093361250	125	4.21
8V1320	G093361320	132	4.45
8V1400	G093361400	140	4.75
8V1500	G093361500	150	5.09
8V1600	G093361600	160	5.44
8V1700	G093361700	170	6.45
8V1800	G093361800	180	6.79
8V1900	G093361900	190	7.14
8V2000	G093362000	200	7.48
8V2120	G093362120	212	7.90
8V2240	G093362240	224	8.48

8V2360 - 8V5600

Description	Part Number	Belt O.C.	Wt. (lbs.)
8V2360	G093362360	236	8.90
8V2500	G093362500	250	8.97
8V2650	G093362650	265	9.05
8V2800	G093362800	280	9.57
8V3000	G093363000	300	10.26
8V3150	G093363150	315	10.78
8V3350	G093363350	335	11.46
8V3550	G093363550	355	12.15
8V3750	G093363750	375	12.84
8V4000	G093364000	400	13.70
8V4250	G093364250	425	14.57
8V4500	G093364500	450	15.43
8V4750	G093364750	475	16.29
8V5000	G093365000	500	17.15
8V5600	G093365600	560	21.42

 Gates Super HC belts are available in 3V, 5V, and 8V cross sections.

Specifications are subject to change without notice or obligation

Applications: Industrial where space, weight and HP are critical



- **Proprietary construction with a superior combination of flex and load carrying capacity**
- **Transmits more horsepower than the classical cross sections in the same amount of drive space**
- **Features notches molded into the belt during manufacturing, a machined belt edge and Flex-Bonded Cords**
- **Meets RMA oil and heat resistant standards**
- **Meets RMA static conductivity requirements**

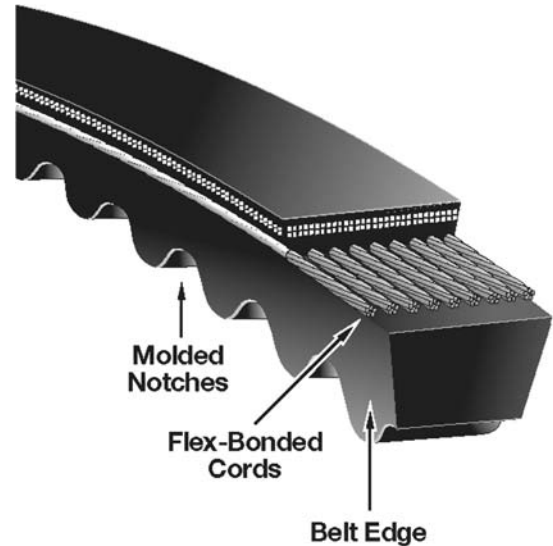

RECOMMENDED PULLEY: Super HC

Gates Super HC® Molded Notch belts are available in 3VX and 5VX cross sections.

3VX BELTS – PART NUMBER SERIES: 9412

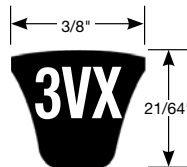

3VX326 - 3VX590

Description	Part Number	Belt O.C.	Wt. (lbs.)
3VX326	G094120326	32.6	0.21
3VX350	G094120350	35.0	0.22
3VX366	G094120366	36.6	0.22
3VX385	G094120385	38.5	0.24
3VX415	G094120415	41.5	0.25
3VX464	G094120464	46.4	0.28
3VX487	G094120487	48.7	0.29
3VX520	G094120520	52.0	0.33
3VX540	G094120540	54.0	0.34
3VX550	G094120550	55.0	0.35
3VX570	G094120570	57.0	0.35
3VX580	G094120580	58.0	0.36
3VX590	G094120590	59.0	0.36

3VX616 - 3VX1296

Description	Part Number	Belt O.C.	Wt. (lbs.)
3VX616	G094120616	61.6	0.38
3VX650	G094120650	65.0	0.39
3VX690	G094120690	69.0	0.41
3VX771	G094120771	77.1	0.44
3VX826	G094120826	82.6	0.45
3VX926	G094120926	92.6	0.49
3VX974	G094120974	97.4	0.49
3VX1027	G094121027	102.7	0.52
3VX1088	G094121088	108.8	0.54
3VX1146	G094121146	114.6	0.55
3VX1224	G094121224	122.4	0.63
3VX1296	G094121296	129.6	0.67



SHIPPING NOTE:

Most Lau products can be shipped normal parcel shipping services, such as FedEx or UPS, but, some products are too large and must be shipped via common carrier.

Next Day or 2nd Day parcel services can be used to ship items at special handling costs. Because the majority of items in this catalog are bulky, we recommend checking with our Customer Service Representatives to verify pricing of expedited service.

Specifications are subject to change without notice or obligation

5VX BELTS

Super HC® “Notched” – Heavy Duty



5VX BELTS – PART NUMBER SERIES: 9414

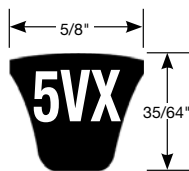

5VX350- 5VX890

Description	Part Number	Belt O.C.	Wt. (lbs.)
5VX350	G094140350	35.0	0.34
5VX362	G094140362	36.2	0.36
5VX372	G094140372	37.2	0.37
5VX382	G094140382	38.2	0.37
5VX392	G094140392	39.2	0.38
5VX402	G094140402	40.2	0.39
5VX412	G094140412	41.2	0.40
5VX422	G094140422	42.2	0.41
5VX433	G094140433	43.3	0.42
5VX459	G094140459	45.9	0.51
5VX479	G094140479	47.9	0.53
5VX519	G094140519	51.9	0.57
5VX619	G094140619	61.9	0.66
5VX700	G094140700	70.0	0.74
5VX720	G094140720	72.0	0.76
5VX760	G094140760	76.0	0.80
5VX769	G094140769	76.9	0.81
5VX790	G094140790	79.0	0.83
5VX867	G094140867	86.7	0.92
5VX890	G094140890	89.0	0.95

5VX918 — 5VX2000

Description	Part Number	Belt O.C.	Wt. (lbs.)
5VX918	G094140918	91.8	0.98
5VX940	G094140940	94.0	0.99
5VX978	G094140978	97.8	1.03
5VX990	G094140990	99.0	1.05
5VX1017	G094141017	101.7	1.08
5VX1050	G094141050	105.0	1.12
5VX1108	G094141108	110.8	1.17
5VX1139	G094141139	113.9	1.22
5VX1162	G094141162	116.2	1.25
5VX1220	G094141220	122.0	1.29
5VX1277	G094141277	127.7	1.41
5VX1374	G094141374	137.4	1.52
5VX1469	G094141469	146.9	1.62
5VX1500	G094141500	150.0	1.67
5VX1700	G094141700	170.0	1.85
5VX1701	G094141701	170.1	1.94
5VX1800	G094141800	180.0	2.02
5VX1900	G094141900	190.0	2.17
5VX2000	G094142000	200.0	2.30



Gates Super HC Molded Notch belts are available in 3VX and 5VX cross sections.



SHIPPING NOTE:

Most Lau products can be shipped normal parcel shipping services, such as FedEx or UPS, but, some products are too large and must be shipped via common carrier.

Next Day or 2nd Day parcel services can be used to ship items at special handling costs. Because the majority of items in this catalog are bulky, we recommend checking with our Customer Service Representatives to verify pricing of expedited service.

Specifications are subject to change without notice or obligation



Engineered to work with Truflex® Belts

- Designed for Truflex® 3L and 4L belts
- Features precision machined grooves, single and double groove designs are available



Solid Type



Spoke Type



Web Type

Bored-to-size (use with Truflex® 3L - 4L Belts) see pages 72 & 73.

* Pulleys up to 3.80" outside diameter are Solid type.

* Pulleys with outside diameters larger than 3.80" are Web and Spoke types.

ONE GROOVE 3L & 4L – PART NUMBER SERIES: 7807 - 7805

Description	Part No. Prefix	O.D. (inches)	Avg. Weight	Pitch Dia.		Bore (inches) – Part Number Suffix											
				3L	4L	1/2	5/8	3/4	7/8	15/16	1	1 1/8	1 1/4	1 3/8	1 1/2		
AK15	G07807	1.50	0.23	1.00	1.30	2046	2047	—	—	—	—	—	—	—	—	—	—
AK17	G07807	1.70	0.23	1.16	1.50	2041	2042	2043	—	—	—	—	—	—	—	—	—
AK20	G07807	2.00	0.35	1.46	1.80	2056	2057	2058	—	—	—	—	—	—	—	—	—
AK21	G07807	2.10	0.46	1.56	1.90	2059	2060	2061	—	—	—	—	—	—	—	—	—
AK22	G07807	2.20	0.58	1.66	2.00	2062	2063	2064	—	—	—	—	—	—	—	—	—
AK23	G07807	2.30	0.58	1.76	2.10	2066	2067	2068	2069	—	—	—	—	—	—	—	—
AK25	G07807	2.50	0.58	1.96	2.30	2083	2084	2085	2086	—	—	—	—	—	—	—	—
AK26	G07807	2.60	0.60	2.06	2.40	2087	2088	2089	—	—	—	—	—	—	—	—	—
AK27	G07807	2.70	0.69	2.16	2.50	2090	2091	2092	—	—	—	—	—	—	—	—	—
AK28	G07807	2.80	0.80	2.26	2.60	2108	2109	2110	2111	—	—	—	—	—	—	—	—
AK28 x 1"	G07807	2.80	0.80	2.26	2.60	—	—	—	—	—	2112	—	—	—	—	—	—
AK30	G07807	3.05	0.98	2.46	2.80	2120	2121	2122	2123	—	—	—	—	—	—	—	—
AK30 x 1"	G07807	3.05	0.98	2.46	2.80	—	—	—	—	—	2125	—	—	—	—	—	—
AK32	G07807	3.25	1.18	2.66	3.00	2402	2403	2404	2405	—	2406	2407	—	—	—	—	—
AK34	G07807	3.45	1.38	2.86	3.20	2144	2145	2146	2147	—	2149	2150	—	—	—	—	—
AK39	G07805	3.75	1.61	3.16	3.50	2412	2413	2414	2415	2418	2416	2417	—	—	—	—	—
AK41	G07805	3.95	1.73	3.36	3.70	2168	2169	2170	2171	2172	2173	2174	—	—	—	—	—
AK44	G07805	4.25	1.73	3.66	4.00	2422	2423	2424	2425	2428	2426	2427	—	—	—	—	—
AK46	G07805	4.45	1.73	3.86	4.20	2192	2193	2194	2195	2196	2197	2198	—	—	—	—	—
AK49	G07805	4.75	1.96	4.16	4.50	2432	2433	2434	2435	2438	2436	2437	—	—	—	—	—
AK51	G07805	4.95	1.96	4.36	4.70	2216	2217	2218	2219	—	2221	2222	—	—	—	—	—
AK54	G07805	5.25	2.07	4.66	5.00	2442	2443	2444	2445	2449	—	2447	—	—	—	—	—
AK54 x 1 1/16"	G07805	5.25	2.07	4.66	5.00	—	—	—	—	—	2446	—	2448	—	—	—	—
AK56	G07805	5.45	2.17	4.86	5.20	2240	2241	2242	2243	2244	2245	2246	2247	—	—	—	—
AK59	G07805	5.75	2.14	5.16	5.50	2250	2251	2252	2253	2254	2255	2256	2257	—	—	—	—
AK61	G07805	5.95	2.37	5.36	5.70	2264	2265	2266	2267	2268	2269	2270	2271	—	—	—	—
AK64	G07805	6.25	2.49	5.66	6.00	2452	2453	2454	2455	2459	2456	2457	2458	—	—	—	—
AK66	G07805	6.45	2.62	5.86	6.20	—	2463	2464	—	—	2466	2467	—	—	—	—	—
AK69	G07805	6.75	2.85	6.16	6.50	—	—	2474	—	—	2476	2477	—	—	—	—	—
AK71	G07805	6.95	4.18	6.36	6.70	—	2483	2484	—	—	2486	2487	—	—	—	—	—
AK74	G07805	7.25	3.84	6.66	7.00	2492	2493	2494	—	2495	2496	2497	2498	2499	—	—	2500
AK79	G07805	7.75	4.40	7.16	7.50	—	—	2504	—	—	2506	2507	—	—	—	—	2510
AK84	G07805	8.25	4.37	7.66	8.00	2532	2533	2534	—	2535	2536	—	2538	—	—	—	2540
AK89	G07805	8.75	4.95	8.16	8.50	—	—	2544	—	—	2546	2547	—	—	—	—	2550
AK94	G07805	9.25	4.20	8.66	9.00	2572	2573	2574	—	2571	2576	—	2578	2579	—	—	2580
AK99	G07805	9.75	4.87	9.16	9.50	—	—	2583	—	—	2586	—	—	—	—	—	—
AK99 x 1 1/16"	G07805	9.75	4.87	9.16	9.50	—	—	—	—	—	—	—	—	—	—	—	2590
AK104	G07805	10.25	5.61	9.66	10.00	—	2613	2614	—	—	2616	—	2618	2619	2621	2620	—
AK109	G07805	10.75	5.73	10.16	10.50	—	—	2644	—	—	2646	—	—	—	—	2648	2640
AK114	G07805	11.25	6.01	10.66	11.00	—	—	2664	—	—	2666	—	2668	—	—	—	2670
AK124	G07805	12.25	7.35	11.66	12.00	—	2703	2704	—	—	2706	—	2708	2709	—	—	2710
AK134	G07805	13.25	8.25	12.66	13.00	—	—	2740	—	—	2741	—	2742	—	—	2743	2744
AK144	G07805	14.25	8.06	13.66	14.00	—	—	2780	—	—	2781	—	2782	—	—	—	2783
AK154	G07805	14.66	11.09	14.66	15.00	—	—	2790	—	—	2791	—	2792	—	—	2794	2793
AK184	G07805	18.25	14.78	17.66	18.00	—	—	2800	—	—	2801	—	2802	—	—	—	2803

Specifications are subject to change without notice or obligation

ONE GROOVE 4L & 5L PULLEYS

Bored-to-Size - Light Duty



ONE GROOVE 4L & 5L - PART NUMBER SERIES: 7807 - 7805

Description	Part No. Prefix	O.D. (inches)	Avg. Weight	Pitch Dia.		Bore (inches) - Part Number Suffix												
				3L	4L	1/2	5/8	3/4	7/8	15/16	1	1 1/8	1 1/4	1 3/8	1 1/2			
BK20	G07807	2.00	0.32	1.30	1.70	3527	3528	3529	—	—	—	—	—	—	—	—	—	—
BK23	G07807	2.25	0.44	1.60	2.00	3539	3540	3541	3542	—	3543	—	—	—	—	—	—	
BK24	G07807	2.40	0.45	1.80	2.20	3545	3546	3547	—	—	—	—	—	—	—	—	—	
BK25	G07807	2.50	0.58	1.90	2.30	3551	3552	3553	3554	—	3555	—	—	—	—	—	—	
BK26	G07807	2.60	0.63	2.00	2.40	3565	3566	3567	3568	—	—	—	—	—	—	—	—	
BK27	G07807	2.70	0.69	2.10	2.50	3575	3576	3577	3578	—	3580	—	—	—	—	—	—	
BK28	G07807	2.95	0.92	2.20	2.60	3587	3588	3589	3590	—	3592	3593	—	—	—	—	—	
BK30	G07807	3.00	0.90	2.44	2.84	3597	3598	3599	3600	—	—	—	—	—	—	—	—	
BK31	G07807	3.25	0.92	2.50	2.90	3907	3908	3909	3916	—	3917	3919	—	—	—	—	—	
BK32	G07807	3.35	0.91	2.60	3.00	3621	3622	3623	3624	—	—	—	—	—	—	—	—	
BK34	G07807	3.55	1.50	2.80	3.20	3611	3612	3613	3614	—	3616	3618	—	—	—	—	—	
BK36	G07805	3.75	1.73	3.00	3.40	3930	3931	3932	3933	—	3934	3935	—	—	—	—	—	
BK40	G07805	3.95	1.73	3.20	3.60	3635	3636	3637	3638	—	3640	3641	—	—	—	—	—	
BK45	G07805	4.25	1.99	3.50	3.90	3950	3951	3952	3953	—	3954	3955	—	—	—	—	—	
BK47	G07805	4.45	2.15	3.70	4.10	5201	5202	5203	5204	—	5205	5238	—	—	—	—	—	
BK50	G07805	4.75	2.00	4.00	4.40	3980	3981	3982	3983	—	3984	3985	—	—	—	—	—	
BK52	G07805	4.95	2.20	4.20	4.60	3683	3684	3685	3686	—	3688	3689	—	—	—	—	—	
BK55	G07805	5.25	2.53	4.50	4.90	5206	5207	5208	5209	—	5210	5211	5239	—	—	—	—	
BK57	G07805	5.45	2.60	4.70	5.10	—	5213	5214	5215	5240	5216	5217	—	—	—	—	—	
BK60	G07805	5.75	2.53	5.00	5.40	4050	4051	4052	4053	—	4054	4055	4056	—	—	—	—	
BK62	G07805	5.95	2.39	5.20	5.60	3731	3732	3733	3734	3692	3736	3737	3738	—	—	—	—	
BK65	G07805	6.25	2.97	5.50	5.90	—	4071	—	—	—	4074	4075	—	—	—	—	—	
BK65 x 3/4	G07805	6.25	2.65	5.50	5.90	—	—	4072	—	—	—	—	—	—	—	—	—	
BK67	G07805	6.45	3.11	5.70	6.10	—	5218	5219	—	—	5221	5222	—	—	—	—	—	
BK70	G07805	6.75	3.50	6.00	6.40	—	5001	5002	—	5241	5004	5005	5006	—	—	—	5008	
BK72	G07805	6.95	3.54	6.20	6.60	—	—	5012	—	—	5014	5242	—	—	—	5243	—	
BK75	G07805	7.25	3.47	6.50	6.90	—	—	5224	—	—	5225	5244	—	—	—	—	—	
BK77	G07805	7.45	4.51	6.70	7.10	—	—	5246	—	—	5247	5248	—	—	—	5249	—	
BK80	G07805	7.75	4.36	7.00	7.40	—	5031	5032	5033	—	5034	5035	5036	5037	5250	5038	—	
BK85	G07805	8.25	4.78	7.50	7.90	—	—	5226	—	—	5227	5251	—	—	—	5252	5253	
BK90	G07805	8.75	5.00	8.00	8.40	—	—	5282	5043	5254	5044	5255	5256	—	—	5257	5258	
BK95	G07805	9.25	5.94	8.50	8.90	—	—	5259	—	—	5260	5261	—	—	—	5262	—	
BK100	G07805	9.75	6.16	9.00	9.40	—	—	5092	5093	—	5094	5095	5096	5097	5266	5098	—	
BK100 x 15/16	G07805	9.75	5.20	9.00	9.40	—	—	—	—	5263	—	—	—	—	—	—	—	
BK105	G07805	10.25	6.02	9.50	9.90	—	—	—	—	—	5265	—	—	—	—	5283	5267	
BK110	G07805	10.75	6.47	10.00	10.40	—	—	5102	—	—	5104	5268	5106	—	—	5269	5270	
BK115	G07805	11.25	6.93	10.50	10.90	—	—	—	—	—	5271	—	—	—	—	—	5272	
BK120	G07805	11.75	7.17	11.00	11.40	—	—	5172	—	—	5174	—	5176	—	—	—	5178	
BK130	G07805	12.75	8.09	12.00	12.40	—	—	6002	—	—	6004	6005	6006	6007	—	—	6008	
BK140	G07805	13.75	8.52	13.00	13.40	—	—	5273	—	—	5274	5275	—	—	—	—	5277	
BK140 x 1 1/16	G07805	13.75	9.03	13.00	13.40	—	—	—	—	—	—	—	5276	—	—	—	—	
BK160	G07805	15.75	12.38	15.00	15.40	—	—	—	—	—	5229	5278	5230	—	—	—	5232	
BK190	G07805	18.75	15.65	18.00	18.40	—	—	—	—	—	—	—	5235	5281	—	—	—	
BK190 x 1 1/16	G07805	18.75	15.50	18.00	18.40	—	—	—	—	—	—	—	—	—	—	—	5237	

Pitch diameter is a reference diameter only.

Bored-to-size (use with Truflex® 4L - 5L Belts) see pages 73 & 74.

Pulleys up to 3.80" outside diameter are Solid type. Pulleys with outside diameters larger than 3.80" are Web and Spoke types.



TWO GROOVE 3L & 4L PULLEYS

Light Duty – Bored-to-Size

TWO GROOVE 3L & 4L – PART NUMBER SERIES: 7807 - 7805

Description	Part No. Prefix	O.D. (inches)	Avg. Weight	Pitch Dia.		Bore (inches) – Part Number Suffix											
				3L	4L	1/2	5/8	3/4	7/8	15/16	1	1 1/8	1 3/16	1 1/2	1 5/16		
2AK20	G07807	2.00	0.89	1.46	1.80	0011	0012	0013	0014	—	—	—	—	—	—	—	—
2AK21	G07807	2.15	0.94	1.56	1.90	0015	0016	—	—	—	—	—	—	—	—	—	—
2AK21 x 3/4	G07807	2.15	0.84	1.56	1.90	—	—	0017	—	—	—	—	—	—	—	—	—
2AK22	G07807	2.25	0.89	1.66	2.00	—	0002	0023	0024	—	0025	—	—	—	—	—	—
2AK22 x 1/2	G07807	2.25	1.01	1.66	2.00	0021	—	—	—	—	—	—	—	—	—	—	—
2AK23	G07807	2.35	1.21	1.76	2.10	—	0032	0033	0034	—	0035	—	—	—	—	—	—
2AK25	G07807	2.55	1.43	1.96	2.30	0111	0112	0113	0114	—	0115	0116	—	—	—	—	—
2AK26	G07807	2.65	1.46	2.06	2.40	—	0117	0118	0119	—	—	—	—	—	—	—	—
2AK27	G07807	2.75	1.65	2.16	2.50	0121	0122	0123	0124	—	0125	0126	—	—	—	—	—
2AK28	G07807	2.85	1.98	2.26	2.60	—	0132	0133	0134	—	0135	—	—	—	—	—	—
2AK30	G07807	3.05	1.98	2.46	2.80	0221	0222	0223	0224	—	0225	0226	—	—	—	—	—
2AK32	G07807	3.25	2.42	2.66	3.00	0141	0142	0143	0144	—	0145	0146	—	—	—	—	—
2AK34	G07807	3.45	2.65	2.86	3.20	0151	0152	0153	0154	—	0155	0156	—	—	—	—	—
2AK39	G07805	3.75	3.21	3.16	3.50	0161	0162	0163	0164	—	0165	0166	—	—	—	—	—
2AK41	G07807	3.95	3.25	3.36	3.70	—	0171	0172	0173	—	0174	0175	—	—	—	—	—
2AK44	G07805	4.25	3.30	3.66	4.00	—	0171	0172	0173	—	0174	0175	—	—	—	—	—
2AK46	G07805	4.45	3.41	3.86	4.20	—	—	—	0178	—	0179	0180	—	—	—	—	—
2AK49	G07805	4.75	3.96	4.16	4.50	—	—	0182	0183	—	0184	0242	—	0243	—	—	—
2AK51	G07805	4.95	4.18	4.36	4.70	—	—	0186	0187	—	0188	0244	—	0245	—	—	—
2AK54	G07805	5.25	3.30	4.66	5.00	—	0189	0190	0191	—	0192	0246	—	0247	—	—	—
2AK56	G07805	5.45	3.74	4.86	5.20	—	0193	0194	—	—	0196	0248	—	0249	—	—	—
2AK59	G07805	5.75	3.49	5.16	5.50	—	—	—	—	—	0250	0251	—	0252	—	—	—
2AK61	G07805	5.95	3.50	5.36	5.70	—	—	0197	0198	—	0199	0253	—	0254	—	—	—
2AK64	G07805	6.25	4.69	5.66	6.00	—	—	0200	—	—	0202	0255	0203	0256	0204	—	—
2AK74	G07805	7.25	6.16	6.66	7.00	—	—	0205	—	—	0206	0257	0207	0258	0208	—	—
2AK84	G07805	8.25	6.44	7.66	8.00	—	—	0209	—	0210	0211	0259	—	0260	0214	—	—
2AK84 x 1 3/16	G07805	8.25	6.54	7.66	8.00	—	—	—	—	—	—	—	0212	—	—	—	—
2AK94	G07805	9.25	7.22	8.66	9.00	—	—	0215	—	—	0217	0261	0218	0262	0219	—	—
2AK104	G07805	10.25	7.26	9.66	10.00	—	—	0220	—	0221	0222	—	—	—	0224	—	—
2AK114	G07805	11.25	8.85	10.66	11.00	—	—	—	—	—	0226	—	0227	0263	0228	—	—
2AK124	G07805	12.25	10.10	11.66	12.00	—	—	—	—	—	0230	—	0231	—	0232	—	—
2AK134	G07805	13.25	11.75	12.66	13.00	—	—	—	—	—	—	—	0264	—	0265	—	—
2AK144	G07805	14.25	12.81	13.66	14.00	—	—	—	—	—	0233	—	—	—	0235	—	—
2AK154	G07805	15.25	13.54	14.66	15.00	—	—	—	—	—	—	—	0237	—	0238	—	—
2AK184	G07805	18.25	18.23	17.66	18.00	—	—	—	—	—	—	—	0240	—	0241	—	—



Pitch diameter is a reference diameter only.



Bored-to-size (use with Truflex® 3L - 4L Belts) see pages 76 & 77.



Pulleys up to 3.80" outside diameter are Solid type. Pulleys with outside diameters larger than 3.80" are Web and Spoke types.



SHIPPING NOTE:

Most Lau products can be shipped normal parcel shipping services, such as FedEx or UPS, but, some products are too large and must be shipped via common carrier.

Next Day or 2nd Day parcel services can be used to ship items at special handling costs. Because the majority of items in this catalog are bulky, we recommend checking with our Customer Service Representatives to verify pricing of expedited service.

Specifications are subject to change without notice or obligation

TWO GROOVE 4L & 5L PULLEYS

Bored-to-Size - Light Duty



TWO GROOVE 4L & 5L - PART NUMBER SERIES: 7807 - 7805

Description	Part No. Prefix	O.D. (inches)	Avg. Weight	Pitch Dia.		Bore (inches) - Part Number Suffix									
				3L	4L	1/2	5/8	3/4	7/8	1	1 1/8	1 1/4	1 3/8	1 1/2	
2BK25	G07807	2.50	1.47	1.90	2.30	7211	7212	7213	7214	7215	—	—	—	—	
2BK27	G07807	2.70	1.83	2.10	2.50	7221	7222	7223	7224	7225	7836	—	—	—	
2BK28	G07807	2.95	2.19	2.20	2.60	7231	7232	7233	7234	7235	7236	—	—	—	
2BK30	G07807	3.15	2.40	2.40	2.80	7837	7838	7839	7840	7841	7842	—	—	—	
2BK32	G07807	3.35	2.94	2.60	3.00	—	7812	7813	7814	7815	7816	—	—	—	
2BK34	G07807	3.55	3.08	2.80	3.20	—	7822	7823	7824	7825	7826	—	—	—	
2BK36	G07805	3.75	3.63	3.00	3.40	—	—	7273	7274	7275	7276	—	7351	—	
2BK40	G07807	3.95	3.80	3.20	3.60	—	—	7831	—	7833	7834	—	7835	—	
2BK40 x 5/8 or 7/8	G07805	3.95	3.94	3.20	3.60	—	7830	—	7832	—	—	—	—	—	
2BK45	G07805	4.25	3.63	3.50	3.90	—	—	—	—	7277	7281	—	7282	—	
2BK47	G07805	4.45	4.07	3.70	4.10	—	—	—	7284	7285	7286	—	—	—	
2BK50	G07805	4.75	4.51	4.00	4.40	—	—	7288	—	7290	7291	—	7292	—	
2BK52	G07805	4.95	4.11	4.20	4.60	—	—	—	7294	7295	7296	—	7297	—	
2BK55	G07805	5.25	4.95	4.50	4.90	—	—	—	—	—	7301	—	7352	—	
2BK57	G07805	5.45	5.00	4.70	5.10	—	—	—	—	7304	7305	—	7353	—	
2BK60	G07805	5.75	5.39	5.00	5.40	—	—	7306	7307	7308	—	—	7354	—	
2BK60 x 1 1/8	G07805	5.75	4.47	5.00	5.40	—	—	—	—	—	7309	—	—	—	
2BK62	G07805	5.95	5.39	5.20	5.60	—	—	—	—	7355	7356	—	7357	—	
2BK65	G07805	6.25	5.50	5.50	5.90	—	—	—	—	7312	7313	—	7358	—	
2BK67	G07805	6.45	5.50	5.70	6.10	—	—	—	—	7315	7316	—	7359	—	
2BK70	G07805	6.75	6.32	6.00	6.40	—	—	7317	—	7318	7360	7319	7361	7320	
2BK80	G07805	7.75	7.92	7.00	7.40	—	—	7321	—	7323	7362	7324	7363	7325	
2BK90	G07805	8.75	8.36	8.00	8.40	—	—	7326	—	7327	7364	7328	7365	7329	
2BK100	G07805	9.75	9.88	9.00	9.40	—	—	7330	—	7332	—	7333	—	—	
2BK100 x 1 3/8 or 1 1/2	G07805	9.75	9.94	9.00	9.40	—	—	—	—	—	—	—	7366	7334	
2BK110	G07805	10.75	11.42	10.00	10.40	—	—	—	—	7335	—	7336	—	7337	
2BK120	G07805	11.75	12.98	11.00	11.40	—	—	—	—	—	—	7340	—	—	
2BK120 x 1	G07805	11.75	13.40	11.00	11.40	—	—	—	—	7339	—	—	—	7341	
2BK130	G07805	12.75	16.39	12.00	12.40	—	—	—	—	7367	—	7368	—	7369	
2BK140	G07805	13.75	19.01	13.00	13.40	—	—	—	—	7342	—	7343	—	—	
2BK140 x 1 1/2	G07805	13.75	16.23	13.00	13.40	—	—	—	—	—	—	—	—	7344	
2BK160	G07805	15.75	19.80	15.00	15.40	—	—	—	—	7345	—	7346	—	7347	
2BK190	G07805	18.75	22.39	18.00	18.40	—	—	—	—	—	—	7349	—	7350	



Pitch diameter is a reference diameter only.



Bored-to-size (use with Truflex® 4L - 5L Belts) see pages 73 & 74.



SHIPPING NOTE:

Most Lau products can be shipped normal parcel shipping services, such as FedEx or UPS, but, some products are too large and must be shipped via common carrier.

Next Day or 2nd Day parcel services can be used to ship items at special handling costs. Because the majority of items in this catalog are bulky, we recommend checking with our Customer Service Representatives to verify pricing of expedited service.

Specifications are subject to change without notice or obligation

Engineered to work with Truflex® Belts



- Precision machined single or double groove designs available
- Suitable for precision applications at high speeds



One-Groove



Two-Groove



- Pitch diameter is a reference diameter only.
- The minimum recommended pitch diameters should be observed for the specific belt section used.



Use with Truflex® 3L - 4L - 5L Belts see pages 72 - 74.

ONE GROOVE 3L - 4L - 5L VARIABLE PITCH – PART NUMBER SERIES: 7810

Description	Part No. Prefix	O.D. (inches)	Avg. Weight	Pitch Diameter						Bore (inches)						
				3L		4L		5L		Part Number Suffix						
				Min.	Max.	Min.	Max.	Min.	Max.	1/2	5/8	3/4	7/8	1	1 1/8	1 1/4
1VP25	G07810	2.32	0.23	1.40	2.20	—	—	—	—	1108	—	—	—	—	—	—
1VP30	G07810	2.87	1.24	1.80	2.70	—	—	—	—	1208	1210	1212	—	—	—	—
1VP34	G07810	3.15	1.60	1.70	2.50	1.90	2.90	2.40	3.20	1308	1310	1312	1314	—	—	—
1VP40	G07810	3.75	2.17	2.30	3.10	2.40	3.40	2.70	2.70	1408	1410	1412	1414	—	—	—
1VP44 (S)	G07810	4.15	3.31	2.70	3.50	2.80	3.80	3.10	4.10	1508	1510	1512	—	—	—	—
1VP44 (L)	G07810	4.15	3.19	2.70	3.50	2.80	3.80	3.10	4.10	—	—	—	1514	1516	1518	—
1VP50 (S)	G07810	4.75	4.14	3.30	4.10	3.40	4.40	3.70	4.70	1608	1610	1612	—	—	—	—
1VP50 (L)	G07810	4.75	3.96	3.30	4.10	3.40	4.40	3.70	4.70	—	—	—	1614	1616	1618	—
1VP56 (S)	G07810	5.35	5.06	3.90	4.70	4.00	5.00	4.30	5.30	1708	1710	1712	—	—	—	—
1VP56 (L)	G07810	5.35	4.84	3.90	4.70	4.00	4.00	4.30	5.30	—	—	—	1714	1716	1718	—
1VP60	G07810	6.00	7.35	—	—	4.20	5.20	4.30	5.30	—	—	1722	1724	—	1728	—
1VP62	G07810	5.95	6.71	4.50	5.30	4.60	5.60	4.90	5.90	—	1810	1812	1814	1816	1818	1822
1VP65	G07810	6.50	7.55	—	—	4.70	5.70	4.80	6.00	—	—	1832	1834	—	1838	—
1VP68 (S)	G07810	6.55	8.18	5.10	5.90	5.20	6.20	6.20	5.50	—	1840	1842	1844	—	1848	—
1VP68 (L)	G07810	6.55	6.95	5.10	5.90	5.20	6.20	6.20	5.50	—	—	—	—	1846	—	1852
1VP71	G07810	7.10	9.38	—	—	5.30	6.30	5.40	6.60	—	—	1882	1884	—	1888	—
1VP75	G07810	7.50	10.40	—	—	5.70	6.70	5.80	7.00	—	—	1862	1864	—	1868	—

TWO GROOVE 3L - 4L - 5L VARIABLE PITCH – PART NUMBER SERIES: 7810

Description	Part No. Prefix	O.D. (inches)	Avg. Weight	Pitch Diameter						Bore (inches)							
				3L		4L		5L		Part Number Suffix							
				Min.	Max.	Min.	Max.	Min.	Max.	1/2	5/8	3/4	7/8	1	1 1/8	1 1/4	1 3/8
2VP36	G07810	3.35	3.88	1.9	2.7	2.0	3.0	2.5	3.5	4358	4360	4362	4364	4366	—	—	—
2VP42	G07810	3.95	4.93	2.5	3.3	2.6	3.6	2.9	3.9	—	4420	4422	4424	4426	4428	—	—
2VP50	G07810	4.75	7.12	3.3	4.1	3.4	4.4	3.7	4.7	—	4610	4612	4614	4616	4618	—	—
2VP56	G07810	5.35	8.81	3.9	4.7	4.0	5.0	4.3	5.3	—	4720	—	4724	4726	4728	—	—
2VP60	G07810	6.00	11.98	—	—	4.2	5.2	4.3	5.5	—	—	4742	4744	—	4748	—	4752
2VP62	G07810	5.95	9.89	4.5	5.3	4.6	5.6	4.9	5.9	—	—	4812	4814	4816	4818	4830	4832
2VP65	G07810	6.50	13.90	—	—	4.7	5.7	4.8	6.0	—	—	4822	4824	—	4828	—	4829
2VP68	G07810	6.55	12.87	5.1	5.9	5.2	6.2	5.5	6.5	—	—	—	4844	4846	4848	4850	4852
2VP71	G07810	7.10	15.49	—	—	5.3	6.3	5.4	6.6	—	—	4882	4884	—	4888	—	4892
2VP75	G07810	7.50	17.14	—	—	5.7	6.7	5.8	7.0	—	—	4862	4864	—	4868	—	4872



Pitch diameter is a reference diameter only.



The minimum recommended pitch diameters should be observed for the specific belt section used.

Specifications are subject to change without notice or obligation

ONE GROOVE 3L & 4L PULLEYS

Taper Bushed – Light Duty



Engineered to work with Truflex® Belts



- Precision machined single or double groove designs available

H Type bushings are sold separately.

Pulleys up to 3.95" diameter are Solid Type.

Pulleys with diameters from 3.95" to 5.25" are Web Type.

Pulleys with diameters larger than 5.25" are Spoke Type.



Taper bushed (use with Truflex® 3L or 4L Belts)
see pages 72 & 73.

ONE GROOVE 3L & 4L – PART NUMBER SERIES: 7801

Description	Part Number	O.D. (Inches)	Pitch Diameter (inches)		Weight Each (Lbs.)
			3L	4L	
AK30H	G078010030	3.05	2.46	2.80	1.21
AK32H	G078010032	3.25	2.66	3.00	1.32
AK34H	G078010034	3.45	2.86	3.20	1.10
AK39H	G078010100	3.75	3.16	3.50	1.54
AK41H	G078010101	3.95	3.36	3.70	1.76
AK44H	G078010102	4.25	3.66	4.00	2.09
AK46H	G078010103	4.45	3.86	4.20	2.09
AK49H	G078010104	4.75	4.16	4.50	2.31
AK51H	G078010105	4.95	4.36	4.70	2.53
AK54H	G078010106	5.25	4.66	5.00	2.53
AK56H	G078010107	5.45	4.86	5.20	2.53
AK59H	G078010108	5.75	5.16	5.50	2.64
AK61H	G078010109	5.95	5.36	5.70	2.75
AK64H	G078010110	6.25	5.66	6.00	2.97
AK66H	G078010111	6.45	5.86	6.20	3.08
AK69H	G078010112	6.75	6.16	6.50	3.52
AK71H	G078010113	6.95	6.36	6.70	3.41
AK74H	G078010114	7.25	6.66	7.00	3.63
AK79H	G078010115	7.75	7.16	7.50	3.85
AK84H	G078010118	8.75	7.66	8.00	3.96
AK89H	G078010116	8.25	8.16	8.50	4.40
AK94H	G078010120	9.25	8.66	9.00	4.84
AK99H	G078010121	9.75	9.16	9.50	5.17
AK104H	G078010122	10.25	9.66	10.00	4.95
AK109H	G078010123	10.75	10.16	10.50	5.61
AK114H	G078010124	11.25	10.66	11.00	6.05
AK124H	G078010126	12.25	11.66	12.00	6.71
AK134H	G078010128	13.25	12.66	13.00	8.14
AK144H	G078010130	14.25	13.66	14.00	8.58
AK154H	G078010131	15.25	14.66	15.00	9.68
AK184H	G078010133	18.25	17.66	18.00	12.43

Specifications are subject to change without notice or obligation

ONE GROOVE 4L & 5L – PART NUMBER SERIES: 7801

Description	Part Number	O.D. (Inches)	Pitch Diameter (inches)		Weight Each (Lbs.)
			3L	4L	
BK30H	G078010140	1.32	2.40	2.80	3.15
BK32H	G078010142	1.54	2.60	3.00	3.35
BK34H	G078010144	1.76	2.80	3.20	3.55
BK36H	G078010150	1.32	3.00	3.40	3.75
BK40H	G078010151	1.54	3.20	3.60	3.95
BK45H	G078010152	1.98	3.50	3.90	4.25
BK47H	G078010153	2.42	3.70	4.10	4.45
BK50H	G078010154	2.20	4.00	4.40	4.75
BK52H	G078010155	2.31	4.20	4.60	4.95
BK55H	G078010156	2.97	4.50	4.90	5.25
BK57H	G078010157	2.97	4.70	5.10	5.45
BK60H	G078010158	2.75	5.00	5.40	5.75
BK62H	G078010159	2.86	5.20	5.60	5.95
BK65H	G078010160	3.08	5.50	5.90	6.25
BK67H	G078010161	3.19	5.70	6.10	6.45
BK70H	G078010162	3.41	6.00	6.40	6.75
BK72H	G078010163	3.25	6.20	6.60	6.95
BK75H	G078010164	3.63	6.50	6.90	7.25
BK77H	G078010165	4.18	6.70	7.10	7.45
BK80H	G078010166	3.74	7.00	7.40	7.75
BK85H	G078010168	4.18	7.50	7.90	8.25
BK90H	G078010169	4.73	8.00	8.40	8.75
BK95H	G078010170	5.50	8.50	8.90	9.25
BK100H	G078010171	5.72	9.00	9.40	9.75
BK105H	G078010172	6.05	9.50	9.90	10.25
BK110H	G078010173	6.60	10.40	10.40	10.75
BK115H	G078010174	7.04	10.50	10.90	11.25
BK120H	G078010175	7.59	11.00	11.40	11.75
BK130H	G078010177	7.59	12.00	12.40	12.75
BK140H	G078010179	9.35	13.00	13.40	13.75
BK150H	G078010180	10.45	14.00	14.40	14.75
BK160H	G078010182	10.78	15.00	15.40	15.75
BK190H	G078010184	14.08	18.00	18.40	18.75



Pitch diameter is a reference diameter only.



SHIPPING NOTE:

Most Lau products can be shipped normal parcel shipping services, such as FedEx or UPS, but, some products are too large and must be shipped via common carrier.

Next Day or 2nd Day parcel services can be used to ship items at special handling costs. Because the majority of items in this catalog are bulky, we recommend checking with our Customer Service Representatives to verify pricing of expedited service.

Specifications are subject to change without notice or obligation

TWO GROOVE 3L-4L-5L PULLEYS

Taper Bushed – Light Duty



TWO GROOVE 3L & 4L – PART NUMBER SERIES: 7801

Description	Part Number	O.D. (Inches)	Pitch Diameter (inches)		Weight Each (Lbs.)
			3L	4L	
2AK30H	G078010197	3.05	2.46	2.80	1.54
2AK32H	G078010198	3.25	2.66	3.00	1.98
2AK34H	G078010199	3.45	2.86	3.20	1.98
2AK39H	G078010200	3.75	3.16	3.50	1.98
2AK41H	G078010201	3.95	3.36	3.70	2.09
2AK44H	G078010202	4.25	3.66	4.00	2.64
2AK46H	G078010203	4.45	3.86	4.20	3.41
2AK49H	G078010204	4.75	4.16	4.50	3.16
2AK51H	G078010205	4.95	4.36	4.70	3.52
2AK54H	G078010206	5.25	4.66	5.00	3.74
2AK56H	G078010207	5.45	4.86	5.20	3.96
2AK59H	G078010208	5.75	5.16	5.50	3.74
2AK61H	G078010209	5.95	5.36	5.70	3.63
2AK64H	G078010210	6.25	5.66	6.00	4.29
2AK74H	G078010214	7.25	6.66	7.00	5.39
2AK84H	G078010218	8.25	7.66	8.00	6.38
2AK94H	G078010220	9.25	8.66	9.00	6.71
2AK104H	G078010222	10.25	9.66	10.00	8.47
2AK114H	G078010224	11.25	10.66	11.00	9.35
2AK124H	G078010226	12.25	11.66	12.00	10.45
2AK134H	G078010228	13.25	12.66	13.00	12.54
2AK144H	G078010230	14.25	13.66	14.00	13.09
2AK154H	G078010231	15.25	14.66	15.00	14.63
2AK184H	G078010233	18.25	17.66	18.00	18.48

TWO GROOVE 4L & 5L – PART NUMBER SERIES: 7801

Description	Part Number	O.D. (Inches)	Pitch Diameter (inches)		Weight Each (Lbs.)
			3L	4L	
2BK32H	G078010248	3.35	2.60	3.00	1.54
2BK34H	G078010249	3.55	2.80	3.20	1.76
2BK36H	G078010250	3.75	3.00	3.40	1.32
2BK40H	G078010251	3.95	3.20	3.60	1.54
2BK45H	G078010252	4.25	3.50	3.90	1.98
2BK47H	G078010253	4.45	3.70	4.10	2.20
2BK50H	G078010254	4.75	4.00	4.40	3.5
2BK52H	G078010255	4.95	4.20	4.60	2.31
2BK55H	G078010256	5.25	4.50	4.90	2.97
2BK57H	G078010257	5.45	4.70	5.10	2.97
2BK60H	G078010258	5.75	5.00	5.40	2.97
2BK62H	G078010259	5.95	5.20	5.60	2.75
2BK65H	G078010260	6.25	5.50	5.90	2.86
2BK67H	G078010261	6.45	5.70	6.10	3.19
2BK70H	G078010262	6.75	6.00	6.40	3.08
2BK80H	G078010266	7.75	7.00	7.40	3.74
2BK90H	G078010269	8.75	8.00	8.40	4.73
2BK100H	G078010271	9.75	9.00	9.40	5.72
2BK110H	G078010273	10.75	10.00	10.40	6.60
2BK120H	G078010275	11.75	11.00	11.40	7.59
2BK130H	G078010277	12.75	12.00	12.40	7.59
2BK140H	G078010279	13.75	13.00	13.40	9.35
2BK160H	G078010282	15.75	15.00	15.40	10.78
2BK190H	G078010284	18.75	18.00	18.40	14.08

Specifications are subject to change without notice or obligation



Proper tension, installation and maintenance can extend belt life and reduce costly downtime. Some of Gates most popular preventive maintenance tools include:

A. SONIC TENSION METER - MODEL 507C

Product No. 7420-0507

For extremely accurate belt tension measuring, the Gates Sonic Tension Meter is an electronic device that measures the natural frequency of a free stationary belt span and instantly computes the static belt tension based upon the belt span length, belt width, and belt type. The Sonic Tension Meter can be used with synchronous and V-belts.

Other features include:

- Output readings can be switched between pounds, kilograms, newtons and hertz.
- Auto gain control automatically adjusts meter sensitivity.
- Auto frequency range filters for background noise.
- Frequency range from 10 - 5,000 Hz.

B. KRIKIT GAUGES

Product No. 7401-0071

For tensioning automotive V-belts up to and including 7/8" top width.

Product No. 7401-0072

For tensioning automotive V-ribbed belts up to 8 ribs in width.

C. PENCIL TYPE TENSION TESTER

Product No. 7401-0076

Maximum deflection force: 30 lbs. For use with all small V-belts and synchronous belts.

D. DOUBLE BARREL TENSION TESTER

Product No. 7401-0075

Maximum deflection force: 66 lbs. For use with all multiple V-belts and large synchronous belts.

E. FIVE BARREL TENSION TESTER

Product No. 7401-0079

Maximum deflection force: 165 lbs. For use with multiple V-belts and large synchronous belts.

F. EZ ALIGN® PRECISION LASER ALIGNMENT DEVICE

Product No. 7420-1000

Identifies common types of pulley misalignment.

G. TRUFLEX® AND POWER RATED® BELT LENGTH FINDER

Product No. 7401-0012

Measures FHP belts up to 107" to determine equivalent Truflex® or Power Rated® belt numbers.

H. SHEAVE GAUGES

Product No. 7401-0014 and 7401-0013

Helps to identify worn sheaves and damaged belts.



SONIC TENSION METER & ACCESSORIES

Part Description	Part Number	(Lbs.)
91104 Belt Length Finder	G074010012	1.75
13998M Pulley Gauge	G074010013	0.02
13998 Pulley Gauge	G074010014	0.02
66 lb. Tension Tester	G074010075	0.42
30 lb. Tension Tester	G074010076	0.14
165 lb. Tension Tester	G074010079	1.00
204 Flexible Sensor	G074200204	0.20
206 Cord Sensor	G074200206	0.20
208 A/C Adapter	G074200208	0.30
212 Inductive Sensor	G074200212	0.20
507C Sonic Tension Meter	G074200507	0.75
EZ Align Laser Tool	G074201000	2.30

General Information

EDGAR LAU SIGNATURE SERIES PREMIUM MOTORS

The Edgar Lau Signature Series Premium Motors give service contractors the option of keeping motors on hand, when they need them, without costly trips to the store for OEM replacements. They reduce fuel consumption and service duration with the same high level of quality and service you have come to expect from all Lau products.

CONDENSER FAN MOTORS

- 48 frame, 5.6 inch diameter
- 208-230V
- 60°C ambient rated
- Mounts with Thru-Bolts, Shell Holes or Belly Band
- 48-inch leads with flag terminals
- Extended mounting studs
- Ball-bearing design
- Reversible rotation
- All-position mount totally enclosed
- Flat lead end for shaft down applications

FURNACE MOTORS

- 48 frame, 5.6 inch diameter
- 1075 RPM applications
- Mounts with Thru-Bolts, Shell Holes or Belly Band
- 36-inch leads
- Extended mounting studs
- 2.5-inch diameter hub rings included
- Reversible rotation
- All-position mount

UNIQUE FEATURES

- Multiple heavy-duty copper windings and ball bearings.
- Services the maximum number of HVAC applications and can **replace five motors with one.**
- Position mounted with extended wiring harnesses for easy installation.
- 48-frame “truck stock” motors come in **seven ranges** for furnace or condenser applications
- Easy to read, color coded packaging with a cross reference and motor wiring diagram on each motor for easy installation.

BENEFITS

- Multiple heavy-duty copper windings achieve multiple horsepower ranges.
- Ball bearings provide an easy, maintenance free service life.
- “Truck Stock” motors enable service contractors to *always* have the right motor on-hand for their work.
- “Truck Stock” motors saves time, service call duration, truck fuel consumption and costly trips back and forth to the shop.

MOTOR TABLE OF CONTENTS

General Information	88
Edgar B. Lau Signature Series Premium Motors	
Direct Drive Furnace Motors.....	89-90
1/2 - 1/6 HP.....	89
3/4 - 1/5 HP.....	90
Condenser Fan Motors.....	91

- **1/2 HP, ball-bearing design, 48 frame, 5.6" diameter, 15 lbs.**
- **Rheem mounting holes**
- **Mounts with thru-bolts, shell holes or belly band**
- **36" leads**
- **Extended mounting studs**
- **2 1/2" diameter hub rings included**
- **Reversible rotation**
- **All-position mount**
- **Color coded packaging**

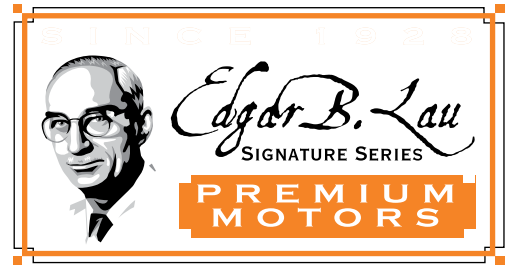

FURNACE MOTOR

Replaces 115V – 1/2-1/6 HP
 Replaces 208-230V – 1/2-1/6 HP

Part Number	Description	Volts	HP	RPM	Product Code
0572700000	Furnace Motor	115	1/2-1/6	1075	1P
0572710000	Furnace Motor	208-230	1/2-1/6	1075	1P

Motor to Replace	Speeds to Use* (Color/Approx. RPM)		370V Capacitor	57270 115V FLA	57271 208-230V FLA
	Cooling	Heating			
1/2 HP	High (Black /1110)	Med-Hi (Blue/1050) or Med-Low (Yellow/825)	10 mfd	7.3	3.6
1/3 HP	High (Black /1120)	Med-Hi (Blue/1090) or Med-Low (Yellow/1030)	5 mfd**	6.9	3.5
1/4 HP	Med-Hi (Blue/1125)	Med-Low (Yellow/1090) or Low (Red/1010)	5 mfd**	5.5	2.8
1/5 HP	Med-Low (Yellow/1110)	Low (Red/1060)	5 mfd**	3.6	1.9
1/6 HP	Low (Red/1085)	Low (Red/1085)	5 mfd**	2.8	1.3

* RPM data from cold motor at nominal horsepower. Actual load will determine effective RPM.

** Using a 7.5 mfd/370V capacitor will result in an approximately 10% stronger motor. This can be used where there is more air flow needed.

Specifications are subject to change without notice or obligation

FURNACE MOTORS



Direct Drive

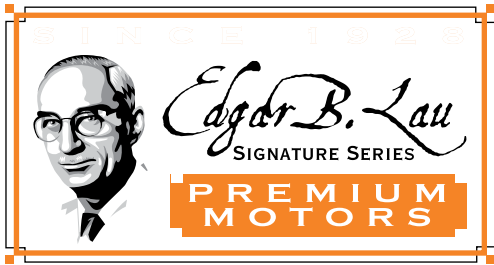

- **3/4 HP, ball-bearing design**
- **48 frame, 5.6" diameter, 22 lbs.**
- **Rheem mounting holes**
- **Mounts with thru-bolts, shell holes or belly band**
- **36" leads**
- **Extended mounting studs**
- **2½" diameter hub rings included**
- **Reversible rotation**
- **All-position mount**
- **Color coded packaging**



FURNACE MOTOR

Replaces 115V – 3/4-1/5 HP
Replaces 208-230V – 3/4-1/5 HP

Part Number	Description	Volts	HP	RPM	Product Code
0572720000	Furnace Motor	115	3/4-1/5	1075	1P
0572730000	Furnace Motor	208-230	3/4-1/5	1075	1P

Motor to Replace	Speeds to Use* (Color/Approx. RPM)		370V Capacitor	57272 115V FLA	57273 208-230V FLA
	Cooling	Heating			
3/4 HP	High (Black/1110)	Med-Hi (Blue/1080) or Med-Low (Yellow/1010)	20 mfd	8.1	3.8
1/2 HP	High (Black/1130)	Med-Low (Yellow/1090) or Low (Red/1035)	10 mfd	6.6	3.7
1/3 HP	Med-Hi (Blue/1150)	Med-Low (Yellow/1030) or Low (Red/1100)	10 mfd	4.6	2.5
1/4 HP	Med-Low (Yellow/1150)	Low (Red/1130)	10 mfd	3.8	1.8
1/5 HP	Low (Red/1140)	Low (Red/1140)	10 mfd	3.1	1.7

* RPM data from cold motor at nominal horsepower. Actual load will determine effective RPM.

Specifications are subject to change without notice or obligation

- 48 frame, 5.6" diameter, all-position, totally enclosed
- Mounts with thru-bolts, shell holes or belly band (extended mounting studs)
- 208-230V, 60°C ambient rated
- 48" leads with flag terminals
- Ball-bearing design and reversible rotation
- Flat lead end for shaft down applications
- Color coded packaging



T MOTOR

Replaces 825 RPM – 1/3-1/6 HP – Wt. 18 lbs.
 Replaces 1075 RPM – 1/3-1/6 HP – Wt. 14 lbs.
 Replaces 1075 RPM – 1/2-1/5 HP – Wt. 19 lbs.

Part Number	Description	Volts	HP	RPM	Product Code
0572670000	Condenser Fan Motor	208-230	1/3-1/6	825	1P
0572680000	Condenser Fan Motor	208-230	1/3-1/6	1075	1P
0572690000	Condenser Fan Motor	208-230	1/2-1/5	1075	1P

825 RPM

Motor to Replace	Speeds to Use* (Color/Approx. RPM)	370V Capacitor	FLA
1/3 HP	High (Black/825)	10	1.9
1/4 HP	High (Black/835)	10	1.5
1/5 HP	Low (Red/825)	10	1.2
1/6 HP	Low (Red/835)	10	1.0

1075 RPM

Motor to Replace	Speeds to Use* (Color/Approx. RPM)	370V Capacitor	FLA
1/3 HP	High (Black/1110)	7.5	2.6
1/4 HP	High (Black/1135)	7.5	2.5
1/5 HP	Low (Red/1110)	7.5	2.0
1/6 HP	Low (Red/1125)	7.5	1.8

1075 RPM

Motor to Replace	Speeds to Use* (Color/Approx. RPM)	370V Capacitor	FLA
1/2 HP	High (Black/1110)	12.5	3.0
1/3 HP	High (Black/1135)	12.5	2.2
1/4 HP	Low (Red/1110)	12.5	1.6
1/5 HP	Low (Red/1125)	12.5	1.3

* RPM data from cold motor at nominal horsepower. Actual load will determine effective RPM.

Specifications are subject to change without notice or obligation

FIRE DAMPERS

Basics



General Information

FIRE DAMPER BASICS

Fire protection is an integral part of building design and construction. In order to help prevent the spread of fire through a building, each floor is subdivided using fire restrictive partitions and/or walls. In the event of a fire, these fire boundaries restrict the spread of flame and heat, which helps minimize life and property loss and helps fire fighters extinguish the fire.

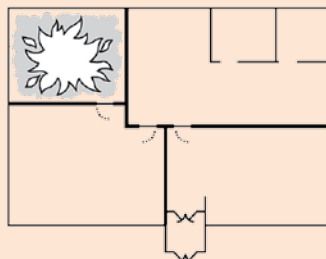

Fire rated partitions contain fire damage to the compartment of fire origin.

Figure 1

It is common for fire to spread from one area to another through the HVAC duct work, so special protection is needed whenever the duct work penetrates a fire-rated partition. Lau curtain-type fire dampers, when properly installed in the plane of the fire wall, will close automatically during a fire and block the flame from spreading (Figure 1).

THERE ARE TWO IMPORTANT CONSIDERATIONS WHEN SELECTING A FIRE DAMPER:

1. Hourly Fire Resistance Rating:

The hourly rating for a fire damper comes from the UL555 Fire Endurance Test and indicates how long a damper will block a fire. Fire dampers in the United States are rated either 1½ or 3 hours.

Any fire rated partition with less than a 3 hour rating requires a 1½ hour rated fire damper.

Any fire rated partition with a 3 hour or more rating requires a 3 hour rated fire damper.

These requirements are based on recommendations made by the National Fire Protection Association (NFPA).

2. Airflow Closure Rating:

Lau curtain-type fire dampers are rated for either static or dynamic HVAC systems and are available in a variety of frame styles. We offer labor saving accessories that save time and money during installation.

Static Fire Dampers have not been tested for closure under airflow and can only be used in HVAC systems that are designed to shut down in the event of a fire (static systems).

Dynamic Fire Dampers have been tested for closure under airflow and carry both an airflow velocity (fpm) and pressure differential rating. Dynamic dampers can be used in both dynamic HVAC systems (fans do not shut off during fire) and static HVAC systems, so they are the preferred damper for retrofit and replacement applications.

Fire Damper Installation Requirements

Lau provides installation instructions detailing the UL approved installation methods and procedures for each damper model. These instructions must be followed accurately to maintain the damper's UL listing. Lau fire dampers have maximum UL listed single section damper sizes for vertical or horizontal mount in smaller openings and maximum UL listed multiple section damper sizes for vertical or horizontal mount in large openings. Size limitations are based solely upon what sizes were actually tested and qualified at the UL Laboratory to meet UL555 requirements.

Lau Fire Dampers are available for either vertical or horizontal mounting. The orientation of the damper must be specified at the time of order.

DAMPER TABLE OF CONTENTS

Fire Damper Basics & Installation Requirements . . .	92-95
Smoke Damper Basics	96
Fire/Smoke Combination Damper Basics	96-97
FM Global Insurance	98
Damper Selection Quick Reference Chart	99-100
Fire/Life Safety Dampers	
Dynamic Fire Dampers	
1½ Hour Rating	101-111
3 Hour Rating	112-117
Assembly & Dimensional Information	118-122
Static Fire Dampers	
1½ Hour Rating	123-131
3 Hour Rating	132-137
Ceiling Radiation Dampers	
General Information	138
Surface Mount	139
CCD7 & CCD7-T- Wood Truss Applications	140-143
UL Floor to Ceiling Comparison Chart	143
CCD8 - Masonry Applications	144
Diffuser Radiation Shields	145
Fire/Smoke Combination Dampers	
General Information	146
1½ Hour UL555S Rated	147-153
Space Envelopes & Dimensional Data	151
Corridor Dampers - 1 Hour UL555S Rated	154-156
Mounting Angles/Actuator Limitation Chart	156
Smoke Dampers	
UL555S Classified	157-159
Access Doors	
Standard & Quick Fit	160-161
Milcor	162
Air Flow Dampers	
Commercial Control Dampers	163-170
Manual Balancing Dampers	171-172
Backdraft Dampers	173-179

Specifications are subject to change without notice or obligation

General Information

GENERAL REQUIREMENTS:

1. Damper Orientation

Vertical Mount Dampers are mounted in vertical walls and partitions, where the duct work or transfer opening runs horizontal.

Horizontal Mount Dampers are mounted in horizontal floors or partitions, where the duct work or transfer opening runs vertical. The fire damper orientation is always perpendicular to the duct work or direction of airflow. The damper typically must be installed within the plane of the wall, floor or partition.

2. Sleeve

Fire dampers require a field- or factory-installed sleeve of sufficient length to permit attachment, with perimeter mounting angles, to duct work on each side of the fire rated partition.

Sleeve gauge requirements are listed in the Lau installation instructions. The sleeve shall not extend more than 6" beyond the fire rated partition unless the damper is equipped with a factory installed access door. For more information about access door and sleeve length/gauge options, contact Lau.

3. Opening Clearance

The opening in the fire rated partition must be larger than the damper/sleeve combination for easy installation and to allow for expansion. Refer to Lau's fire damper installation instructions for specific opening requirements.

4. Mounting Angles

Mounting angles are required for UL approved installation of fire dampers. Angles must be at least 1½" x 1½" x 20 gauge steel, and must overlap the partition a minimum of 1". Lau offers FAST angles for one sided installation or PFMA angles for two sided installation. Both angle styles conform to UL requirements.

Figures 2 and 3 illustrate typical horizontal and vertical fire damper installation. Refer to Lau's fire damper installation instructions for additional requirements and special applications.

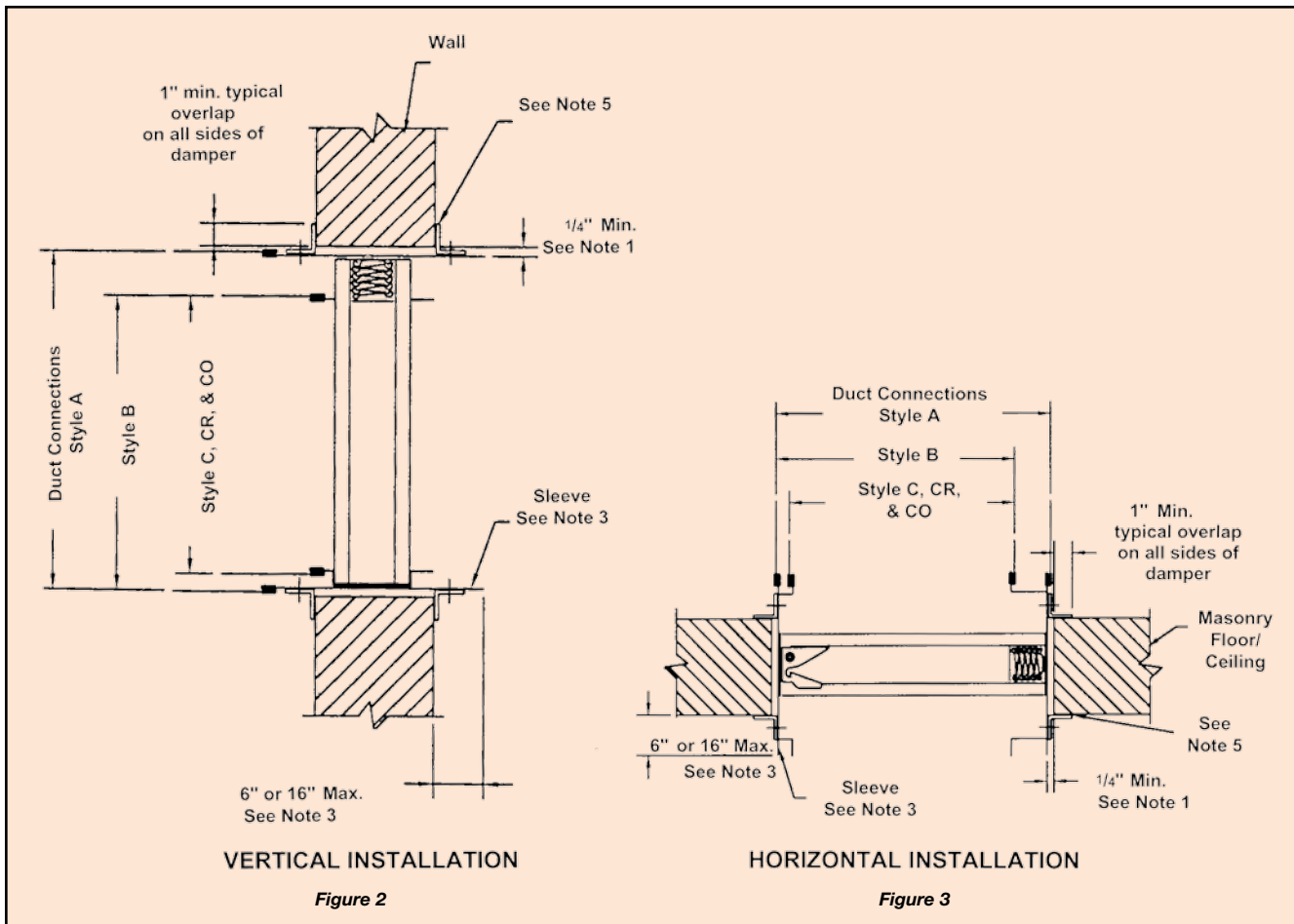

Contact Lau for additional fire damper assistance.

Specifications are subject to change without notice or obligation

FIRE DAMPERS

Curtain Type



General Information

DYNAMIC & STATIC FIRE DAMPERS (TRANSITION STYLES)

A Style

- Frame and blades in the airstream
- 75-85% free area

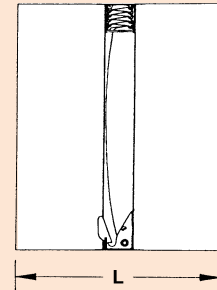
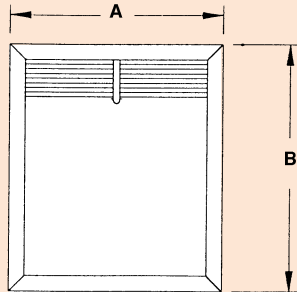

L = LENGTH OF SLEEVE
S = DAMPER SET BACK

B Style

- Blades out of the airstream
- 80-90% free area
- Not air tight

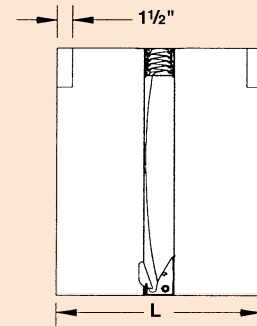
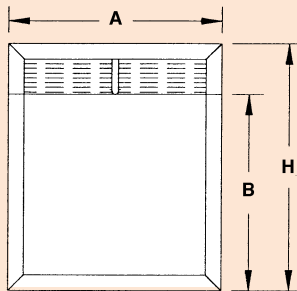

BC Style

- Fully welded B style
- 80-90% free area
- Requires minimum 12" sleeve

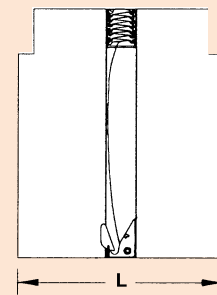
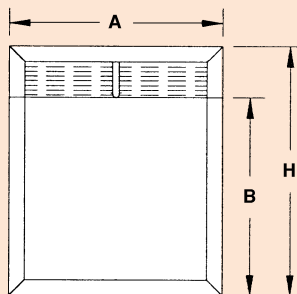

C, WC Style

- Square or rectangular enclosure
- 95-100% free area
- C – sealed
- WC – welded

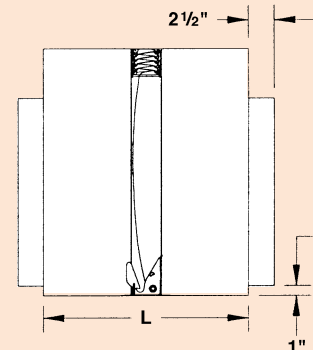
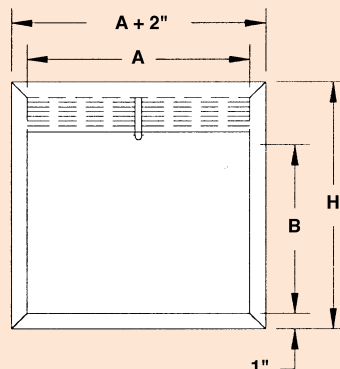

Specifications are subject to change without notice or obligation

DYNAMIC & STATIC FIRE DAMPERS (TRANSITION STYLES)

CO, LO, WO Style

- Oval enclosure
- 95-100% free area
- CO – sealed
- WO – welded
- LO – not air tight



L = LENGTH OF SLEEVE
S = DAMPER SET BACK

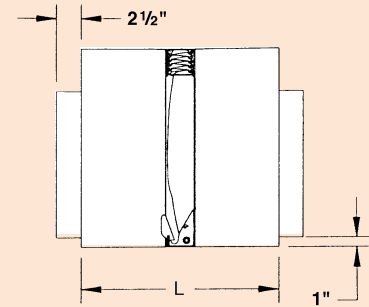
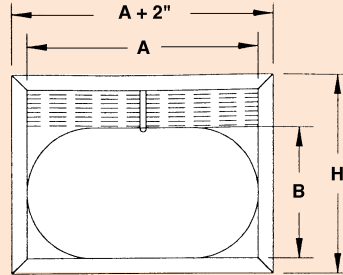

CR, LR, WR Style

- Round enclosure
- 95-100% free area
- CR – sealed
- WR – welded
- LR – not air tight

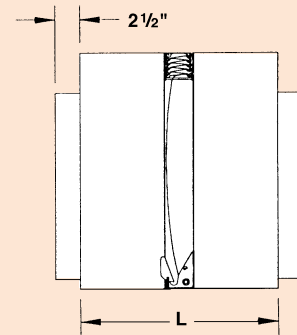
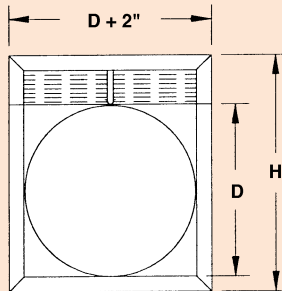

R Style

- Round enclosure
- Blades partially in air stream
- Not air tight

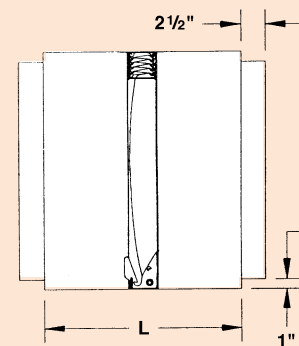
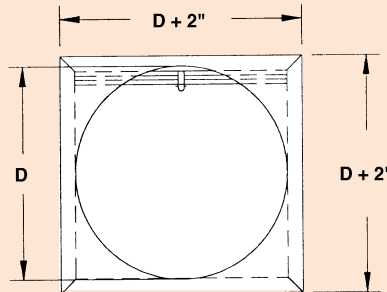

G Style

- Grille applications
- Damper set back to accept grille
- Mounting tabs on front replace retaining angle and accept steel grille

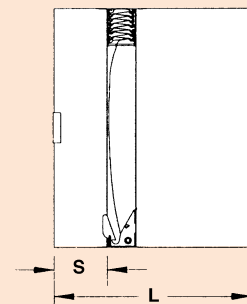
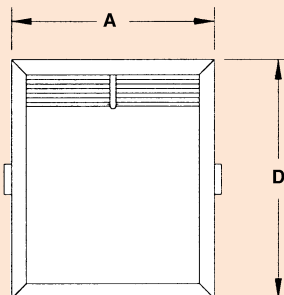

Specifications are subject to change without notice or obligation

SMOKE DAMPERS

Basics



General Information

SMOKE DAMPERS

All smoke detectors require factory installed actuators, either electric or pneumatic. They are controlled by a smoke or heat detector signal, fire alarm or other building control system.

Smoke Dampers are qualified under UL Standard 555S, *Leakage Rated Dampers for Use in Smoke Control Systems*. Lau smoke detectors are always supplied with the appropriate factory mounted actuator and UL label. UL555S requires all smoke dampers to be rated for operation with an approved actuator at a minimum airflow velocity of 2,000 fpm when open, and against a minimum pressure of 4 inches w.g. during closure. Smoke dampers should be specified based on the conditions they will be exposed to in their application.

GENERAL APPLICATIONS:

1. Passive Smoke Control Systems

The damper closes upon detection of smoke to prevent the circulation of air and smoke through a duct or ventilation opening.

2. Engineered Smoke Control System

The damper operates as part of a system designed to control smoke migration using walls and floors as barriers and fans to create pressure differentials. Pressurizing the areas surrounding the fire prevents the spread of smoke into other areas (Figure 4).

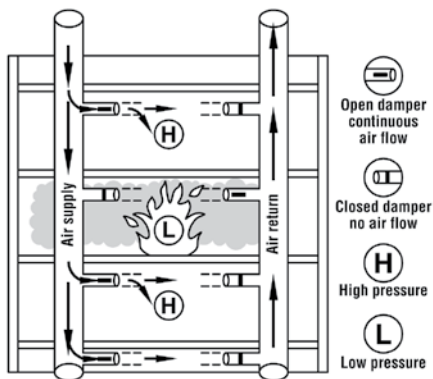

Engineered Smoke Control System – Smoke is contained to the fire zone by higher pressures in adjacent zones.

Figure 4

There are two important considerations when selecting a smoke damper:

1. Leakage Rating

The leakage rating of a smoke damper comes from the UL555S Leakage Test. Ratings are Class 1 (lowest leakage) and Class 2 & 3 (highest leakage).

2. Elevated Temperature Rating

Lau smoke dampers are available with elevated temperature ratings of 250°F (standard) and 350°F.

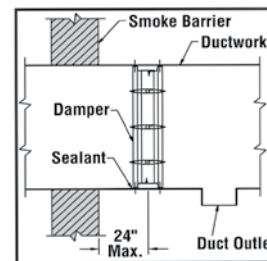

Figure 5

Typical Smoke Damper Installation

SMOKE DAMPER INSTALLATION REQUIREMENTS

Lau provides installation instructions detailing the UL approved installation methods and procedures for each damper model. These instructions must be followed accurately to maintain the damper's UL listing.

Lau smoke dampers have maximum UL listed single section damper sizes for smaller openings and a maximum UL listed multiple section damper size for large openings. Size limitations are based solely upon what size dampers were actually tested and qualified at the UL Laboratory to meet UL555S requirements.

GENERAL REQUIREMENTS:

1. Location

The smoke damper must be installed no more than 24" from the smoke barrier it is intended to protect.

2. Attachment

Lau's smoke damper installation instructions include the approved method for attachment and spacing of the attachments (Figure 5).

3. Sealing

The joints between the damper frame and the duct must be sealed to prevent unwanted air leakage.

FIRE/SMOKE COMBINATION DAMPERS

Basics



General Information

COMBINATION FIRE/SMOKE DAMPERS

Combination Fire/Smoke Dampers function as both a fire damper and a smoke damper in a single unit. HVAC system designers often combine smoke barriers and fire rated partitions, requiring both a fire damper and a smoke damper to be installed in the same location. A combination Fire/Smoke damper is recommended in this situation.

Lau Fire/Smoke dampers meet the requirements of both UL Standards 555 (fire dampers) and 555S (smoke dampers).

All combination Fire/Smoke dampers require factory installed actuators, either electric or pneumatic. They are controlled by a smoke or heat detector signal, fire alarm or other building control system to prevent the spread of smoke. Manual or automatic override allows the damper to be used as part of an engineered smoke control system. When temperatures exceed the closure

temperature of the damper, the blades close and lock to protect the integrity of the fire rated partition. Lau Fire/Smoke dampers are always supplied with the appropriate factory-mounted actuator and UL label.

Leakage Class	Maximum Leakage in CFM/Sq. Ft.		
	@1" w.g.	@4" w.g.	@8" w.g.
Class 1	4	8	11
Class 2	10	20	28
Class 3	40	80	112

UL555S LEAKAGE RATING

Figure 6

Specifications are subject to change without notice or obligation

General Information

There are five important considerations when ordering a Fire/Smoke damper:

1. Fire Resistance Rating

The hourly fire resistance rating for a combination fire/smoke damper comes from the UL555 Fire Endurance Test and indicates how long a damper will block a fire. Fire/Smoke dampers in the United States are rated either 1½ or 3 hours.

Any fire rated partition with less than a 3 hour rating requires a 1½ hour rated Fire/Smoke damper.

Any fire rated partition with a 3 hour or more rating requires a 3 hour rated Fire/Smoke damper.

These requirements are based on recommendations made by the National Fire Protection Association (NFPA). All Fire/Smoke dampers in this catalog are 1½ hour fire rated. For dampers with 3 hour rating, contact Lau.

2. Leakage Rating

The leakage rating for a combination Fire/Smoke damper comes from the UL555S Leakage Test. Ratings are Class 1 (lowest leakage), Class 2, and Class 3 (highest leakage). Figure 6 shows the maximum leakage in CFM/Sq. Ft. for each leakage class.

HVAC system designers are advised to select the lowest leakage class damper, however there are some smoke control applications when a higher leakage class damper is acceptable. Consult your local building codes for specific application requirements.

3. Elevated Temperature Rating

UL classifies Fire/Smoke dampers by the maximum temperature they can withstand and still operate in their intended manner. UL's Temperature Degradation Test requires the damper and its installed actuator to be exposed to an elevated temperature for 30 minutes and immediately cycled for operational acceptance. Temperature ratings are 250°F and 350°F.

Lau Fire/Smoke dampers are supplied with a 250°F elevated temperature rating unless otherwise specified.

4. Operational Rating

Both UL Standards 555 and 555S require that a Fire/Smoke damper and its installed actuator be rated for minimum airflow velocity of 2,000 fpm through the open damper and minimum pressure of 4 inches w.g. across the closed damper. The actuator is rated for the largest size damper it will actuate and must operate the damper open and closed against the rated velocities and pressures.

5. Actuator Type and Mounting

UL Standards 555 and 555S require testing both the damper and its installed actuator. This limits the approved actuators that can be used on Fire/Smoke dampers. Actuators must be furnished by the manufacturer and factory installed in order for the damper to bear the UL label.

Lau offers a selection of UL approved electric and pneumatic actuators. Electric actuators are available in 24VAC and 120VAC. Pneumatic actuators require 25 to 30 psi control air to each actuator location.

Each specific actuator model has a series of maximum damper size ratings depending on the damper model, airflow velocity through the open damper, and the maximum pressure differentials that will build up across the closed damper. Typically, actuators for Fire/Smoke dampers are selected based on size of damper (in square feet) they will be controlling.

Lau Fire/Smoke dampers are supplied with the actuator mounted out of airstream on the factory-supplied sleeve, in compliance with UL requirements. Contact Lau with questions about other actuator mounting options.

FIRE/SMOKE DAMPER INSTALLATION REQUIREMENTS

Lau provides installation instructions detailing the UL approved installation methods and procedures for each damper model. These instructions must be followed accurately to maintain the damper's UL listing.

Lau Fire/Smoke dampers have maximum UL listed single section sizes for smaller openings and a maximum UL listed multiple section damper size for larger openings. Size limitations are based solely upon what size dampers were actually tested and qualified at the UL Laboratory to meet the UL555 and UL555S requirements.

GENERAL REQUIREMENTS:

1. Sleeve Requirements

UL requires all Fire/Smoke dampers be mounted in a steel sleeve of the appropriate gauge and length prior to installation. The damper/sleeve assembly is then installed in the fire wall or floor opening with retaining angles attached to the sleeve. The damper assembly becomes part of the wall/floor and the duct is connected to the end of the damper sleeve.

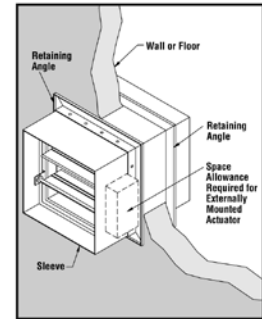

Figure 7

The length of the damper sleeve is determined by the thickness of the wall/floor it will be installed in as well as the actuator, accessories and options on the damper. The sleeve may not extend more than 6" beyond the fire rated partition unless the damper is equipped with a factory installed access door. The sleeve may not extend more than 16" beyond the wall on the actuator side.

Sleeve gauge is determined by the size of the damper, the gauge of the duct to which it will be connected, and the type of duct-to-sleeve connections used. For more information about access door and sleeve length/gauge options, contact Lau.

2. Expansion Gap

Typically the fire rated partition must be a minimum of 1/4" larger than the width and height of the damper/sleeve assembly. The expansion gap must increase 1/8" for each foot the damper exceeds 2 feet on the width or height.

3. Space Envelope

When a Fire/Smoke damper is installed it must fit in a space with room for wiring or piping. The actuator and accessories must be accessible for testing and service or replacement. Lau Fire/Smoke damper actuators and accessories are normally externally mounted on the right side of the sleeve.

Figure 7 shows a typical Fire/Smoke damper installation.

DAMPER MAINTENANCE

Owners of buildings or their agents should establish planned maintenance schedules for fire, smoke, and combination Fire/Smoke dampers. Failure to properly maintain the dampers may be a contributing cause of fires and/or loss of life.

The National Fire Protection Association's recommendations regarding maintenance can be found in NFPA90A and NFPA92A. In addition, the actuator manufacturers make maintenance and cycling recommendations in their product literature.

Lau's operating and maintenance instructions can be found in Appendix C.

FM GLOBAL INSURANCE



FM Approval

WHO IS FM?

FM Global is one of the world's largest commercial and industrial property insurance organizations. They manage a nonprofit scientific research and testing organization (Factory Mutual Research) which tests and provides approvals for building products to help minimize losses in buildings they insure.

WHY SPECIFY PRODUCTS APPROVED BY FM?

The simple answer is to reduce property loss risks. Architects, consulting engineers, plant managers, contractors, or anyone concerned with minimizing risk in equipment or the buildings they are designing or operating should insist on the use of products approved by FM. Specifying and ultimately utilizing products approved by FM means protecting property or equipment with the highest quality products available. More than one out of every three Fortune 1,000 companies, as well as leading international corporations, profit by utilizing products approved by FM and the lower insurance costs resulting from their use.

LAU PRODUCTS APPROVED BY FM

Lau Fire, Smoke and Combination Fire/Smoke Dampers qualify as FM Approvals Specification Tested Products. Using the Lau products listed below can aid the building owner in getting or maintaining favorable insurance rates.



FIRE DAMPERS

- C12
- CP2
- CP23
- CP25
- CPD2
- CPD12
- CPD23
- CPD25
- CPD35
- CPDR25
- CPT1
- CPT2

SMOKE DAMPERS

- CSD36
- CSD37
- CSDRS25

FIRE SMOKE DAMPERS

- CFS1
- CFS2
- CFS2C
- CFSR25

Specifications are subject to change without notice or obligation



DAMPER SELECTION

Quick Reference Chart

DYNAMIC FIRE DAMPERS - FOR "FANS ON" SYSTEMS							
Model	UL555 Rating	Blades In/Out of Airstream	Features	Minimum Size		Maximum Size	
				Vertical	Horizontal	Vertical	Horizontal
CPD2A	1½ hour	IN		6"w x 6"h	6"w x 6"h	72"w x 48"h 48"w x 72"h or 120"w x 24"	36"w x 48"h
CPD2B	1½ hour	OUT		6"w x 4"h	6"w x 4"h	72"w x 45"h 48"w x 69"h or 120"w x 21"h	36"w x 42"h
CPD2R	1½ hour	IN	Round duct transition	3"	4"	31"	20"
CPD2LR	1½ hour	OUT	Round duct transition	3"	4"	31"	20"
CPD2G	1½ hour	IN	Grille-mount style	4"w x 4"h	6"w x 6"h	32"w x 36"h	24"w x 24"h
CPD12A	1½ hour	IN	12" integral sleeve	4"w x 4"h	6"w x 6"h	72"w x 48"h 48"w x 72"h or 84"w x 24"	36"w x 48"h
CPD12B	1½ hour	OUT	12" integral sleeve	6"w x 4"h	6"w x 4"h	72"w x 45"h 48"w x 69"h or 84"w x 21"	36"w x 42"h
CPD12R	1½ hour	IN	12" integral sleeve, Round duct transition	3"	4"	31"	20"
CPD12LR	1½ hour	OUT	12" integral sleeve, Round duct transition	3"	4"	31"	20"
CPD35	1½ hour	IN	Multi-Blade Damper	8"w x 6"h	8"w x 6"h	72"w x 96"h or 126"w x 48"h	72"w x 96"h or 144"w x 48"h
CPDR25	1½ hour	IN	True Round Damper	6"	6"	24"	24"
CPD23A	3 hour	IN		4"w x 4"h	6"w x 6"h	72"w x 48"h, 48"w x 72"h or 90"w x 24"	36"w x 48"h
CPD23B	3 hour	OUT		6"w x 4"h	6"w x 4"h	72"w x 45"h, 48"w x 69"h or 90"w x 21"	36"w x 42"h
CPD23R	3 hour	IN	Round duct transition	3"	4"	31"	20"
CPD23LR	3 hour	OUT	Round duct transition	3"	4"	31"	20"
CPD25A	3 hour	IN	12" integral sleeve	4"w x 4"h	6"w x 6"h	72"w x 48"h, 48"w x 72"h or 84"w x 24"	36"w x 48"h
CPD25B	3 hour	OUT	12" integral sleeve	6"w x 4"h	6"w x 4"h	72"w x 45"h, 48"w x 69"h or 84"w x 21"	36"w x 42"h
CPD25R	3 hour	IN	12" integral sleeve, Round duct transition	3"	4"	31"	20"
CPD25LR	3 hour	OUT	12" integral sleeve, Round duct transition	3"	4"	31"	20"
STATIC FIRE DAMPERS - FOR "FANS OFF" SYSTEMS							
Model	UL555 Rating	Blades In/Out of Airstream	Features	Minimum Size		Maximum Size	
				Vertical	Horizontal	Vertical	Horizontal
CP2A	1½ hour	IN		4"w x 4"h	6"w x 6"h	120"w x 72"h	114"w x 38"h or 90"w x 91"h
CP2B	1½ hour	OUT		4"w x 4"h	6"w x 4"h	120"w x 65"h	114"w x 33"h or 90"w x 81"h
CP2R	1½ hour	IN	Round duct transition	4"	4"	31"	31"
CP2LR	1½ hour	OUT	Round duct transition	4"	4"	31"	31"
CP2G	1½ hour	IN	Grille-mount style	4"w x 4"h	6"w x 6"h	49"w x 32"h or 32"w x 49"h	24"w x 18"h or 18"w x 24"h
C12A	1½ hour	IN	12" integral sleeve	4"w x 4"h	6"w x 6"h	84"w x 72"h	84"w x 84"h
C12B	1½ hour	OUT	12" integral sleeve	4"w x 4"h	6"w x 4"h	84"w x 65"h	84"w x 74"h

Specifications are subject to change without notice or obligation

DAMPER SELECTION



Quick Reference Chart

STATIC FIRE DAMPERS - FOR "FANS OFF" SYSTEMS - Continued							
Model	UL555 Rating	Blades In/Out of Airstream	Features	Minimum Size		Maximum Size	
				Vertical	Horizontal	Vertical	Horizontal
C12R	1½ hour	IN	12" integral sleeve, Round duct transition	4"	4"	31"	31"
C12LR	1½ Hour	OUT	12" integral sleeve, Round duct transition	4"	4"	31"	31"
CPT, T1, T2A	1½ hour	IN	Thinline	4"w x 4"h	6"w x 6"h	40"w x 48"h	60"w x 12"h
CPT, T1, T2B	1½ hour	OUT	Thinline	4"w x 4"h	6"w x 6"h	40"w x 48"h	60"w x 12"h
CP23A	3 hour	IN		4"w x 4"h	6"w x 6"h	90"w x 72"h	90"w x 91"h
CP23B	3 hour	OUT		4"w x 4"h	6"w x 4"h	90"w x 68"h	90"w x 81"h
CP23R	3 hour	IN	Round duct transition	4"	4"	31"	28"
CP23LR	3 hour	OUT	Round duct transition	4"	4"	31"	28"
CP25A	3 hour	IN	12" integral sleeve	4"w x 4"h	6"w x 6"h	84"w x 72"h	84"w x 84"h
CP25B	3 hour	OUT	12" integral sleeve	4"w x 4"h	6"w x 4"h	84"w x 68"h	84"w x 74"h
CP25R	3 hour	IN	12" integral sleeve, Round duct transition	4"	4"	31"	28"
CP25LR	3 hour	OUT	12" integral sleeve, Round duct transition	4"	4"	31"	28"

CEILING RADIATION DAMPERS

Model	Round or Rectangular	Application	Features	Minimum Size	Maximum Size
CCD	Rectangular	Surface mount		5"w x 4"h	324 in ² , max 24" width or height
CCDR	Round	Surface mount		5"	20"
CCD5	Rectangular	Lay-in	Thermal insulating blanket	4"w x 5"h	18"w x 18"h
CCDR5	Round	Lay-in	Thermal insulating blanket	5"	20"
CCD7	Rectangular	Wood Truss		5"w x 4"h	18"w x 18"h
CCD7-T	Rectangular	Wood Truss		5"w x 4"h	18"w x 18"h

FIRE/SMOKE COMBINATION DAMPERS

Model	UL555 Hourly Rating	UL555 Leakage Class	Features	Minimum Size		Maximum Size	
				Vertical	Horizontal	Vertical	Horizontal
CFS1	1½ Hour	Class 1		8"w x 6"h	8"w x 6"h	120"w x 96"h	144"w x 96"h
CFS2	1½ Hour	Class 2		8"w x 6"h	8"w x 6"h	126"w x 96"h or 72"w x 122"h	144"w x 96"h
CFSR25	1½ hour	Class 1	True Round Damper	6"	6"	24"	24"
CFS2C	1½ hour	Class 2	Corridor Damper	N/A	8"w x 6"h	N/A	24"w x 24"h

SMOKE DAMPERS

Model	UL555S Leakage Class	Features	Minimum Size		Maximum Size	
			Vertical	Horizontal	Vertical	Horizontal
CSD37	Class 1		8"w x 6"h	8"w x 6"h	144"w x 96"h, 72"w x 144"h or 288"w x 48"h	144"w x 96"h, 72"w x 144"h or 288"w x 48"h
CSD36	Class 2		8"w x 6"h	8"w x 6"h	144"w x 96"h, 72"w x 144"h or 288"w x 48"h	144"w x 96"h, 72"w x 144"h or 288"w x 48"h
CSDRS25	Class 1	True Round Damper	5"	5"	24"	24"

UL Minimum and Maximum sizes shown. Maximum sizes shown may be multiple-section assembly. Refer to each model for Maximum single-section sizes.

CPD2 – STYLE A Blades In Airstream 1½ Hour Rating

APPLICATION

CPD2 Style A fire dampers can be installed vertically in walls or horizontally in floors with fire resistance ratings of less than 3 hours. The CPD2 carries a 1½ hour UL fire damper label and is classified as a dynamic damper for use in HVAC systems that remain in operation during a fire. The CPD2 is rated for dynamic closure to 2,000 fpm and 4 inches w.g. static pressure. Ratings are for in duct and in wall/floor installations with horizontal airflow and vertical airflow, both up and down.

STANDARD CONSTRUCTION

FRAME

20 gauge galvanized, steel channel.

BLADES

24 gauge galvanized curtain type in airstream.

CLOSURE SPRINGS (if required)

301 stainless steel constant force type.

FUSIBLE LINK

165°F is standard. 212°F and 285°F available.

DAMPER SIZES

MINIMUM SIZE

Vertical Installation – 4" w x 4" h

Horizontal Installation – 6" w x 6" h

MAXIMUM SIZE

Single-Section

Vertical Installation – 33" w x 36" h

Horizontal Installation – 24" w x 24" h

Multiple-Section

Vertical Installation – 72" w x 48" h, 48" w x 72" h or

120" w x 24" h

Horizontal Installation – 36" w x 48" h

OPTIONS

- **Switch Package** to remotely indicate damper blade position.
- **FAST Angle** for one side angle installations.
- **G Style** for grille applications.
- **GA, Grille Access Type** for out of the wall/floor and no angle grille applications.
- **Sleeve** of various lengths and gauges to insure field compliance with UL installation requirements.
- **Access Door** factory mounted in common sleeve to ensure compliance with UL installation requirements.
- **FM Approval.**

Model CPD2 meets the requirements for fire dampers established by:

- **National Fire Protection Association** NFPA Standards 90A and 101
- **BOCA National Building Codes**
- **ICBO Uniform Building Codes**
- **SBCCI Standard Building Codes**
- **IBC International Building Codes**
- **CSFM California State Fire Marshal** (consult Lau for complete list of CSFM listed products)

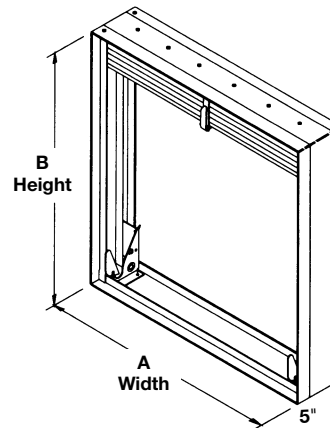

Taped and sealed on vertical sizes up to 33" w x 36" h and horizontal sizes up to 24" w x 24" h.

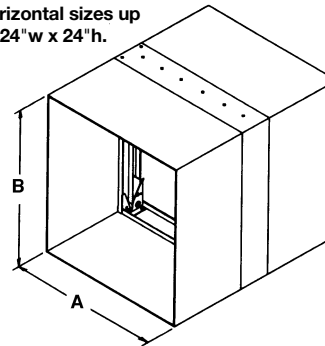

CPD2 STYLE A IN FACTORY SLEEVE

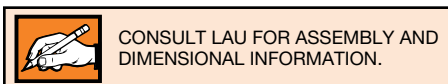

DYNAMIC FIRE DAMPERS

Use in Dynamic & Static Systems



CPD2 – STYLE B

Blades Out of Airstream

1½ Hour Rating

APPLICATION

CPD2 Style B fire dampers can be installed vertically in walls or horizontally in floors with fire resistance ratings of less than 3 hours. The CPD2 carries a 1½ hour UL fire damper label and is classified as a dynamic damper for use in HVAC systems that remain in operation during a fire. The CPD2 is rated for dynamic closure to 2,000 fpm and 4 inches w.g. static pressure. Ratings are for in duct and in wall/floor installations with horizontal airflow and vertical airflow, both up and down.

STANDARD CONSTRUCTION

FRAME

20 gauge galvanized, steel channel.

BLADES

24 gauge galvanized curtain type, out of airstream for high free area applications.

CLOSURE SPRINGS (if required)

301 stainless steel constant force type.

FUSIBLE LINK

165°F is standard. 212°F and 285°F available.

DAMPER SIZES

MINIMUM SIZE

Vertical Installation – 6"w x 4"h

Horizontal Installation – 6"w x 4"h

MAXIMUM SIZE

Single-Section

Vertical Installation – 33"w x 32"h

Horizontal Installation – 24"w x 21"h

Multiple-Section

Vertical Installation – 72"w x 45"h, 48"w x 69"h or

120"w x 21"h

Horizontal Installation – 36"w x 42"h

OPTIONS

- **Switch Package** to remotely indicate damper blade position.
- **FAST Angle** for one side angle installations.
- **G Style** for grille applications.
- **GA, Grille Access Type** for out of the wall/floor and no angle grille applications.
- **Sleeve** of various lengths and gauges to insure field compliance with UL installation requirements.
- **Access Door** factory mounted in common sleeve to ensure compliance with UL installation requirements.
- **FM Approval.**

Model CPD2 meets the requirements for fire dampers established by:

- **National Fire Protection Association NFPA Standards 90A and 101**
- **BOCA National Building Codes**
- **ICBO Uniform Building Codes**
- **SBCCI Standard Building Codes**
- **IBC International Building Codes**
- **CSFM California State Fire Marshal** (consult Lau for complete list of CSFM listed products)



SEE COMPLETE
MARKING ON
PRODUCT

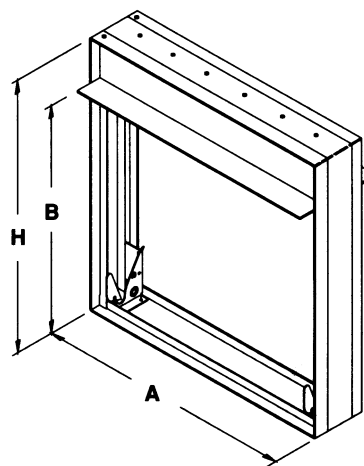

Taped and sealed on vertical sizes up to 33"w x 32"h and horizontal sizes up to 24"w x 21"h.

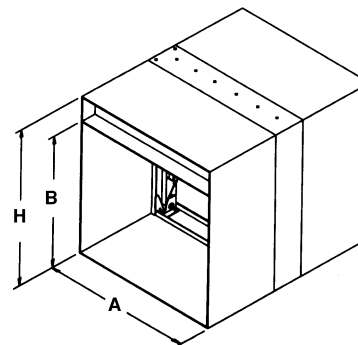

CPD2 STYLE B IN FACTORY SLEEVE



CONSULT LAU FOR ASSEMBLY AND DIMENSIONAL INFORMATION.

Specifications are subject to change without notice or obligation

CPD2 – STYLES R, LR Round Duct Transition 1½ Hour Rating

APPLICATION

CPD2 Styles R and LR fire dampers can be installed vertically in walls or horizontally in floors with fire resistance ratings of less than 3 hours. The CPD2 Style R and LR carry a 1½ hour UL fire damper label and are classified as dynamic dampers for use in HVAC systems that remain in operation during a fire. The **CPD2 Style LR** features a non-sealed round transition for low pressure, 100% free area applications while the **Style R** features a non-sealed round transition for low pressure and less than 100% free area applications.

The CPD2 is rated for dynamic closure to 2,000 fpm and 4 inches w.g. static pressure. Ratings are for in duct wall/floor installations with horizontal airflow and vertical airflow, both up and down.

STANDARD CONSTRUCTION

FRAME

20 gauge galvanized steel channel.

BLADES

24 gauge galvanized curtain type in air stream.

DUCT COLLARS

24 gauge x 2½" long galvanized steel.

CLOSURE SPRINGS (if required)

301 stainless steel constant force type.

FUSIBLE LINK

165°F is standard. 212°F and 285°F available.

DAMPER SIZES

MINIMUM SIZE

Vertical Installation
Styles R, LR – 3" diameter
Horizontal Installation
Styles R, LR – 4" diameter

MAXIMUM SIZE

Single Section
Vertical Installation
Styles R, LR – 31" diameter
Horizontal Installation
Styles R, LR – 20"

OPTIONS

- **Switch Package** to remotely indicate damper blade position.
- **FAST Angle** for one side angle installations.
- **G Style** for grille applications.
- **GA, Grille Access Type** for out of the wall/floor and no angle grille applications.
- **Sleeve** of various lengths and gauges to insure field compliance with UL installation requirements.
- **Access Door** factory mounted in common sleeve to ensure compliance with UL installation requirements.
- **Fire Stop Caulk Installation.**
- **FM Approval.**

Model CPD2 meets the requirements for fire dampers established by:

- **National Fire Protection Association NFPA Standards 90A and 101**
- **BOCA National Building Codes**
- **ICBO Uniform Building Codes**
- **SBCCI Standard Building Codes**
- **IBC International Building Codes**
- **CSFM California State Fire Marshal** (consult Lau for complete list of CSFM listed products)

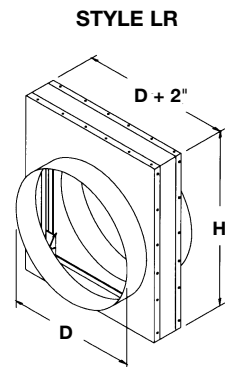
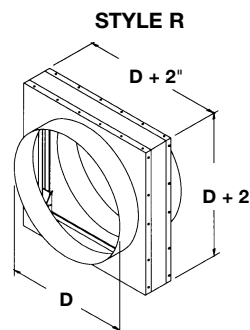

CPD2 STYLE LR IN FACTORY SLEEVE

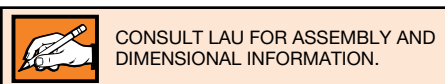
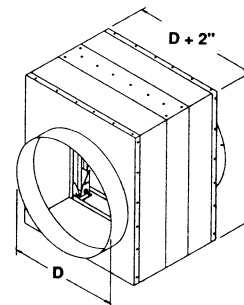

DYNAMIC FIRE DAMPERS

Use in Dynamic & Static Systems



CPD2 – STYLE G

Grille Mount

1½ Hour Rating

APPLICATION

CPD2 Style G dynamic rated grille mount fire dampers can be installed vertically in walls or horizontally in floors with fire resistance ratings of less than 3 hours. G style grille mount fire dampers are offset in a sleeve with 3/4" grille mounting flanges. The damper and sleeve assembly fits flush in the wall or floor opening and the customer supplied steel frame grille installs over and completely conceals the mounting flanges. For out of the wall or floor grille applications and no angle applications refer to the GA type fire dampers.

STANDARD CONSTRUCTION

FRAME

20 gauge galvanized, steel channel.

BLADES

24 gauge galvanized curtain type in airstream.

CLOSURE SPRINGS (if required)

301 stainless steel constant force type.

FUSIBLE LINK

165°F is standard. 212°F and 285°F available.

DAMPER SIZES

MINIMUM SIZE

Vertical Installation – 4"w x 4"h

Horizontal Installation – 6"w x 6"h

MAXIMUM SIZE

Vertical Installation – 33"w x 32"h

Horizontal Installation – 24"w x 18"h or 18"w x 24"h

OPTIONS

- **Switch Package** to remotely indicate damper blade position.
- **FAST Angle** for one side angle installations.
- **GA, Grille Access Type** for "out of the wall" and no angle grille applications.
- **Sleeve** of various lengths and gauges to insure field compliance with UL installation requirements.
- **Access Door** factory mounted in common sleeve to ensure compliance with UL installation requirements.
- **FM Approval.**

Model CPD2 meets the requirements for fire dampers established by:

- **National Fire Protection Association NFPA Standards 90A and 101**
- **BOCA National Building Codes**
- **ICBO Uniform Building Codes**
- **SBCCI Standard Building Codes**
- **IBC International Building Codes**
- **CSFM California State Fire Marshal** (consult Lau for complete list of CSFM listed products)

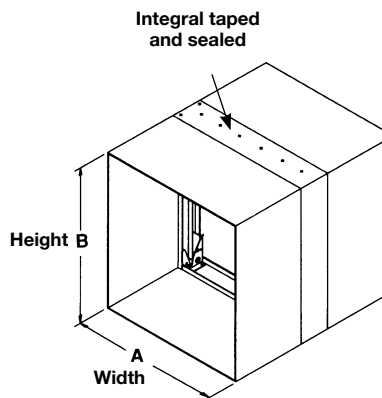

CPD2 in Sleeve (required) shown

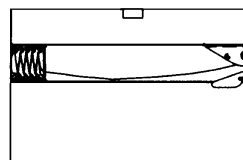

HORIZONTAL

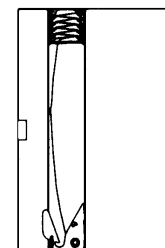

VERTICAL



1. Damper/sleeve assemblies furnished actual size.
2. Refer to Style G Installation Instructions and supplements for complete installation details.
3. Consult Lau for Assembly and Dimensional Information.

Specifications are subject to change without notice or obligation

CPD2 – STYLE G Grille Mount 1½ Hour Rating

HOW TO APPLY

1. Size the damper (A x B).
2. Determine the set back dimension (S). See note 1.
3. Calculate sleeve length (L). See note 2.
4. Determine air flow direction (vs, vr etc.) and indicate on order.
5. Install the damper per the UL approved installation instructions. See note 3.



1. CPD2 Style G must be ordered with a sleeve and is available with a standard S dimension of 2¼". Other set back dimensions are available and must be specified.
2. To calculate sleeve length (L), determine wall, floor or ceiling thickness and add 3" minimum. For example: A 6" wall would require a minimum 9" sleeve. This would allow 3" of sleeve opposite the grille for retaining angles and duct connections.
3. For "out of walls" no angle installation or installation from one side of wall, consult Lau.

HC
Horizontal Ceiling Return

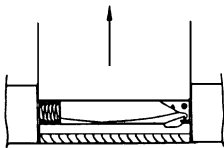

VS
Vertical Supply

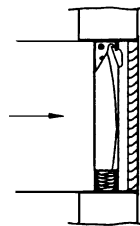

VR
Vertical Return

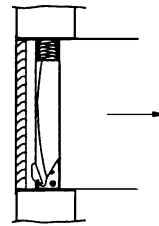

HFS
Horizontal Floor Supply

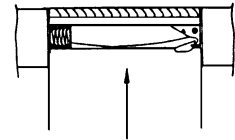

HCS
Horizontal Ceiling Supply

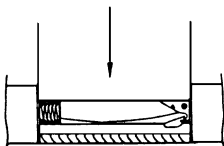

Arrow Indicates Airflow Direction

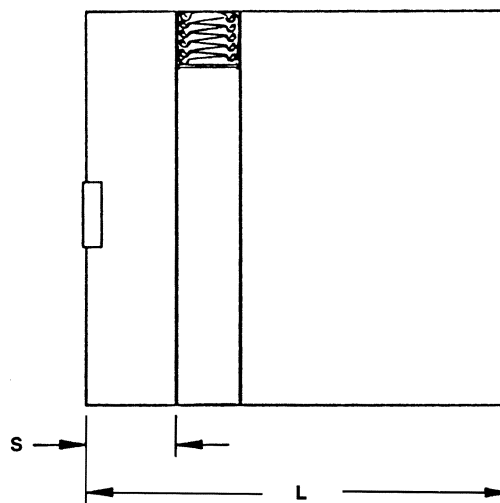

HFR
Horizontal Floor Return

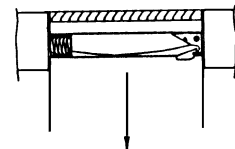

SHIPPING NOTE:

Most Lau products can be shipped normal parcel shipping services, such as FedEx or UPS, but, some products are too large and must be shipped via common carrier.

Next Day or 2nd Day parcel services can be used to ship items at special handling costs. Because the majority of items in this catalog are bulky, we recommend checking with our Customer Service Representatives to verify pricing of expedited service.

DYNAMIC FIRE DAMPERS

Use in Dynamic & Static Systems



CPD12 – STYLE A Integral Sleeve, Blades In Airstream 1½ Hour Rating

APPLICATION

CPD12 Style A fire dampers can be installed vertically in walls or horizontally in floors with fire resistance ratings of less than 3 hours. The CPD12 carries a 1½ hour UL fire damper label and is classified as a dynamic damper for use in HVAC systems that remain in operation during a fire. The CPD12 is rated for dynamic closure to 2,000 fpm and 4 inches w.g. static pressure. Ratings are for in duct and in wall/floor installations with horizontal airflow and vertical airflow, both up and down.

STANDARD CONSTRUCTION

FRAME/SLEEVE

20 gauge x 12" galvanized, steel channel.

BLADES

24 gauge galvanized curtain type in airstream.

CLOSURE SPRINGS (if required)

301 stainless steel constant force type.

FUSIBLE LINK

165°F is standard. 212°F and 285°F available.

DAMPER SIZES

MINIMUM SIZE

Vertical Installation – 4"w x 4"h

Horizontal Installation – 6"w x 6"h

MAXIMUM SIZE

Single-Section

Vertical Installation – 33"w x 36"h

Horizontal Installation – 24"w x 24"h

Multiple-Section

Vertical Installation – 72"w x 48"h, 48"w x 72"h or

84"w x 24"h

Horizontal Installation – 36"w x 48"h

OPTIONS

- **Switch Package** to remotely indicate damper blade position.
- **FAST Angle** for one side angle installations.
- **G Style** for grille applications.
- **Access Door** factory mounted in common sleeve to ensure compliance with UL installation requirements.
- **Fire Stop Caulk Installation.**
- **FM Approval.**

Model CPD12 meets the requirements for fire dampers established by:

- **National Fire Protection Association NFPA Standards 90A and 101**
- **BOCA National Building Codes**
- **ICBO Uniform Building Codes**
- **SBCCI Standard Building Codes**
- **IBC International Building Codes**
- **CSFM California State Fire Marshal** (consult Lau for complete list of CSFM listed products)

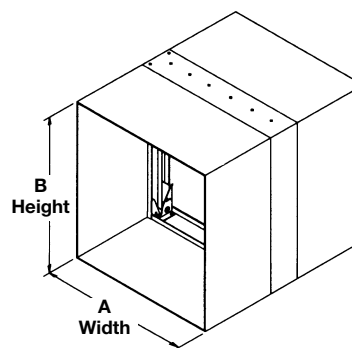

VERTICAL MOUNT

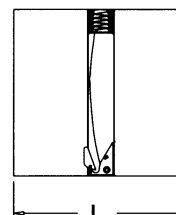

L = Frame/Sleeve Length

HORIZONTAL MOUNT

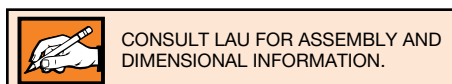
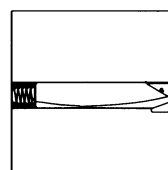

Specifications are subject to change without notice or obligation

CPD12 – STYLE B Integral Sleeve, Blades Out of Airstream 1½ Hour Rating

APPLICATION

CPD12 Style B fire dampers can be installed vertically in walls or horizontally in floors with fire resistance ratings of less than 3 hours. The CPD12 carries a 1½ hour UL fire damper label and is classified as a dynamic damper for use in HVAC systems that remain in operation during a fire. The CPD12 is rated for dynamic closure to 2,000 fpm and 4 inches w.g. static pressure. Ratings are for in duct and in wall/floor installations with horizontal airflow and vertical airflow, both up and down.

STANDARD CONSTRUCTION

FRAME/SLEEVE

20 gauge x 12" galvanized, steel channel.

BLADES

24 gauge galvanized curtain type in airstream.

CLOSURE SPRINGS (if required)

301 stainless steel constant force type.

FUSIBLE LINK

165°F is standard. 212°F and 285°F available.

DAMPER SIZES

MINIMUM SIZE

Vertical Installation – 6"w x 4"h

Horizontal Installation – 6"w x 4"h

MAXIMUM SIZE

Single-Section

Vertical Installation – 33"w x 32"h

Horizontal Installation – 24"w x 21"h

Multiple-Section

Vertical Installation – 72"w x 45"h, 48"w x 69"h or

84"w x 21"h

Horizontal Installation – 36"w x 42"h

OPTIONS

- **Switch Package** to remotely indicate damper blade position.
- **FAST Angle** for one side angle installations.
- **G Style** for grille applications.
- **Access Door** factory mounted in common sleeve to ensure compliance with UL installation requirements.
- **Fire Stop Caulk Installation.**
- **FM Approval.**

Model CPD12 meets the requirements for fire dampers established by:

- **National Fire Protection Association NFPA Standards 90A and 101**
- **BOCA National Building Codes**
- **ICBO Uniform Building Codes**
- **SBCCI Standard Building Codes**
- **IBC International Building Codes**
- **CSFM California State Fire Marshal** (consult Lau for complete list of CSFM listed products)

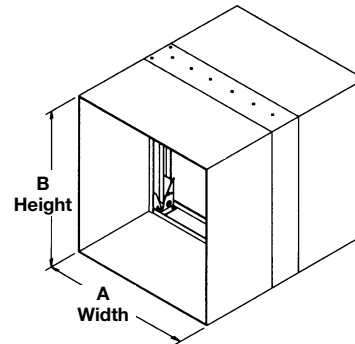

VERTICAL MOUNT

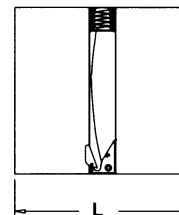

L = Frame/Sleeve Length

HORIZONTAL MOUNT

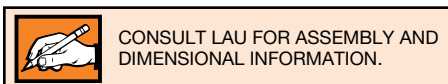
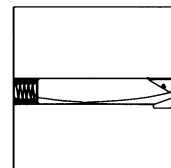

DYNAMIC FIRE DAMPERS

Use in Dynamic & Static Systems



CPD12 – STYLES R, LR Integral Sleeve, Round Duct Transition 1½ Hour Rating

APPLICATION

CPD12 Styles R and LR fire dampers can be installed vertically in walls or horizontally in floors with fire resistance ratings of less than 3 hours. The CPD12 carries a 1½ hour UL fire damper label and is classified as a dynamic damper for use in HVAC systems that remain in operation during a fire. The CPD12 Style R and LR feature a non-sealed transition for low pressure, 100% free area applications (Style R does not allow 100% free area).

The CPD12 is rated for dynamic closure to 2,000 fpm and 4" w.g. static pressure. Ratings are for in duct wall/floor installations with horizontal airflow and vertical airflow, both up and down.

STANDARD CONSTRUCTION

FRAME/SLEEVE

20 gauge x 12" galvanized, steel channel.

BLADES

24 gauge galvanized curtain type in airstream.

CLOSURE SPRINGS (if required)

301 stainless steel constant force type.

FUSIBLE LINK

165°F is standard. 212°F and 285°F available.

DAMPER SIZES

MINIMUM SIZE

Vertical Installation
Styles R, LR – 3" diameter
Horizontal Installation
Styles R, LR – 4" diameter

MAXIMUM SIZE

Single Section
Vertical Installation
Styles R, LR – 31" diameter
Horizontal Installation
Styles R, LR – 20" diameter

OPTIONS

- **Switch Package** to remotely indicate damper blade position.
- **FAST Angle** for one side angle installations.
- **G Style** for grille applications.
- **Sleeve** of various lengths and gauges to insure field compliance with UL installation requirements.
- **Access Door** factory mounted in common sleeve to ensure compliance with UL installation requirements.
- **Fire Stop Caulk Installation.**
- **FM Approval.**

Model CPD12 meets the requirements for fire dampers established by:

- **National Fire Protection Association NFPA Standards 90A and 101**
- **BOCA National Building Codes**
- **ICBO Uniform Building Codes**
- **SBCCI Standard Building Codes**
- **IBC International Building Codes**
- **CSFM California State Fire Marshal** (consult Lau for complete list of CSFM listed products)



STYLE R

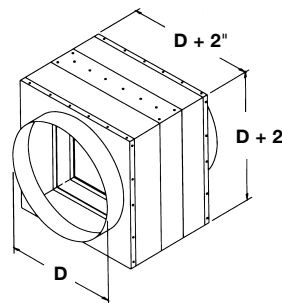

STYLE LR

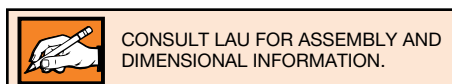
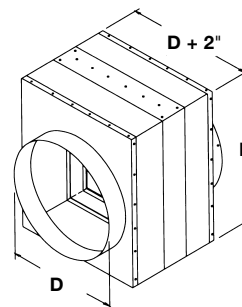

Specifications are subject to change without notice or obligation

CPD35 Multiple Blade Damper 1½ Hour Rating

APPLICATION

The CPD35 Multiple Blade damper is a triple vee-groove blade dynamic fire damper. It is rated for 4,000 fpm and 8 inches w.g. but designed for systems with velocities no higher than 2,000 fpm and pressures no higher than 4 inches w.g. The CPD35 is rated for dual directional air flow and can be installed in walls or floors.

STANDARD CONSTRUCTION

FRAME

5" x 1" x 16 gauge galvanized, hat-shaped steel channel, structurally superior to 13 gauge channel frame.

BLADES

6" wide, 16 gauge galvanized steel, approximately 6" on center.

BEARINGS

Stainless steel sleeve, pressed into frame.

BLADE SEALS

Blade edge overlap for flame seal to 1,900°F.

LINKAGE

Concealed in frame.

AXLES

1/2" plated steel hex.

FUSIBLE LINK

165°F standard. 212°F or 285°F available.

DAMPER SIZES

MINIMUM SIZE

8"w x 6"h

MAXIMUM SIZE

Single-Section – 36"w x 48"h

Multiple-Section

Vertical Installation – 72"w x 96"h or 126"w x 48"h

Horizontal Installation – 72"w x 96"h or 144"w x 48"h

OPTIONS

- **GA, Grille Access Type** for out of wall/floor or grille applications.
- **SP100 Switch Package** to remotely indicate damper blade position.
- **FAST Angle** for one side angle installations.
- **Sleeve** of various lengths and gauges to insure field compliance with UL installation requirements.
- **Access Door** factory mounted in common sleeve to ensure compliance with UL installation requirements.
- **Jamb Seals**, stainless steel flexible metal compression type.
- **Blade Seals**, silicone blade edge seals.
- **FM Approval.**

Model CPD35 meets the requirements for fire dampers established by:

- **National Fire Protection Association NFPA Standards** 90A, 92A, 92B and 101
- **BOCA National Building Codes**
- **ICBO Uniform Building Codes**
- **SBCCI Standard Building Codes**
- **IBC International Building Codes**
- **CSFM California State Fire Marshal** (consult Lau for complete list of CSFM listed products)

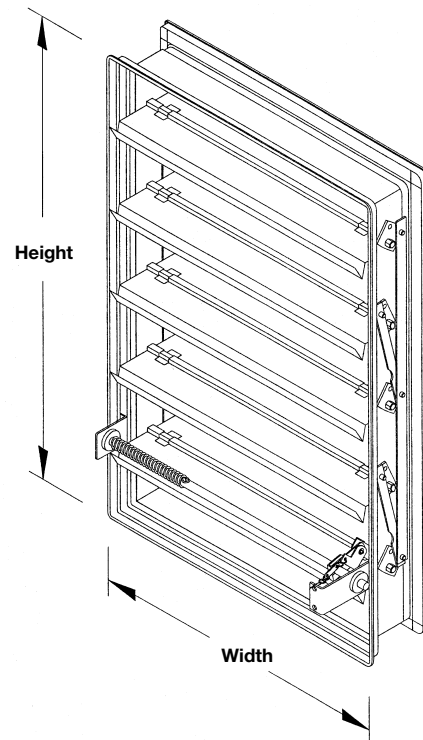

1. Unit furnished approximately 1/4" smaller than given opening dimensions.
2. Consult Lau for Assembly and Dimensional Information.

Specifications are subject to change without notice or obligation

DYNAMIC FIRE DAMPERS

Use in Dynamic & Static Systems



CPDR25 Round Fire Damper 1½ Hour Rating

APPLICATION

The CPDR25 is a “true” round fire damper designed for use in fire rated walls and floors and is the perfect choice when using round duct.

The CPDR25 is rated for maximum velocity of 2,000 fpm and 4 inches w.g. static pressure. The integral frame and unique “cinch plate” design provides a low cost, high performing damper. When the CPDR25 reaches a job site nothing else is required in order to install the damper. The CPDR25 now has UL approval for plate on one-side of metal stud or concrete walls.

Model CPDR25 meets the requirements for fire dampers established by:

- **National Fire Protection Association NFPA Standards 90A, 92A, 92B and 101**
- **BOCA National Building Codes**
- **ICBO Uniform Building Codes**
- **SBCCI Standard Building Codes**
- **IBC International Building Codes**
- **CSFM California State Fire Marshal** (consult Lau for complete list of CSFM listed products)

STANDARD CONSTRUCTION

FRAME/SLEEVE

20 gauge galvanized steel, standard 14" integral sleeve and retaining “cinch” plates. (See minimum sleeve length chart below for assistance in choosing correct sleeve length. Sleeves available up to 36" in length.)

BLADES

Single skin 14 gauge equivalent thickness galvanized steel.

BEARINGS

Stainless steel sleeve, pressed into frame.

AXLE

1/2" diameter.

FUSE LINK

165°F is standard. 212°F or 285°F available at additional cost.

DAMPER SIZES

MINIMUM SIZE

6" diameter

MAXIMUM SIZE

Vertical/Horizontal – 24" diameter.

OPTIONS

- **Sleeve/Frame** of various lengths to insure field compliance with UL installation requirements.
- **FM Approval.**

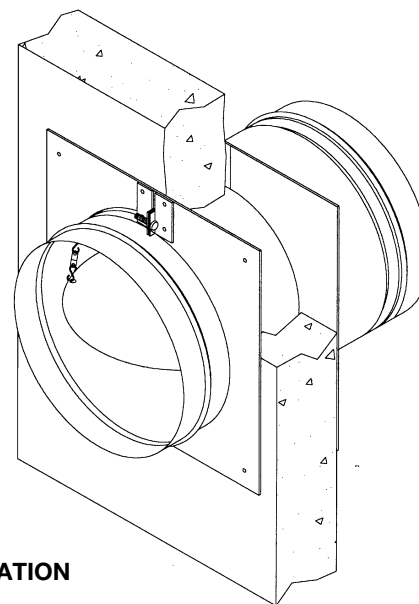

DIMENSIONAL INFORMATION

MINIMUM SLEEVE LENGTH

Wall/Floor Thickness	Min. Sleeve Length
4"	14"
5"	14"
6"	14"
7"	17"
8"	17"
9"	17"
10"	20"
12"	20"
Over 12" Thru 24"	Add 1" for every inch of wall/floor depth

NOTE: 36" maximum sleeve length.

1. Unit furnished approximately 1/8" smaller than given size.
2. Consult Lau for Assembly and Dimensional Information.

Specifications are subject to change without notice or obligation

CPDR25 Round Fire Damper 1½ Hour Rating

GENERAL INSTALLATION INFORMATION

METAL/ WOOD/MASONRY WALL OR CONCRETE FLOOR INSTALLATION

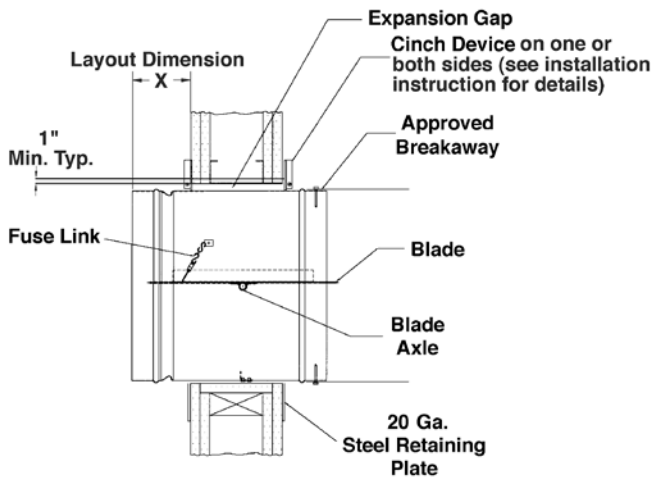

A **square** opening in wood or metal stud walls or masonry walls and floors shall be a minimum of 1" and a maximum of 2½" larger than the damper diameter. See wood stud and metal stud framing for fire dampers installation instructions supplement for complete framing details. A **round** opening in masonry walls or floors shall be a minimum of 1" and a maximum of 2½" larger than the damper diameter.

Factory supplied retaining "cinch" plates hold the damper within the wall opening. The plates must overlap the opening a minimum of 1/2". The plate fits snugly around the integral sleeve. The plates are fastened directly to the wall or floor.

RETAINING "CINCH" PLATES

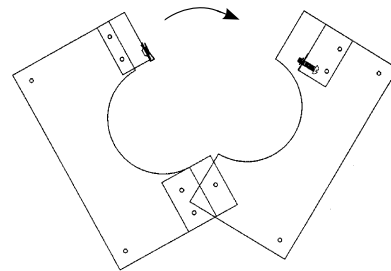
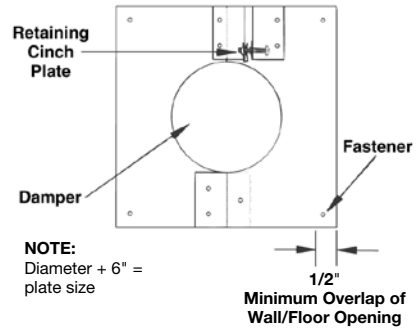

Refer to the CPDR25 Installation Instructions for complete installation details.



SHIPPING NOTE:

Most Lau products can be shipped normal parcel shipping services, such as FedEx or UPS, but, some products are too large and must be shipped via common carrier.

Next Day or 2nd Day parcel services can be used to ship items at special handling costs. Because the majority of items in this catalog are bulky, we recommend checking with our Customer Service Representatives to verify pricing of expedited service.

DYNAMIC FIRE DAMPERS

Use in Dynamic & Static Systems



CPD23 – STYLE A Blades In Airstream 3 Hour Rating

APPLICATION

CPD23 Style A fire dampers can be installed vertically in walls or horizontally in floors with fire resistance ratings of 3 hours or more. The CPD23 carries a 3 hour UL fire damper label and is classified as a dynamic damper for use in HVAC systems that remain in operation during a fire. The CPD23 is rated for dynamic closure to 2,000 fpm and 4 inches w.g. static pressure. Ratings are for in duct and in wall/floor installations with horizontal airflow and vertical airflow, both up and down.

STANDARD CONSTRUCTION

FRAME

20 gauge galvanized, steel channel.

BLADES

24 gauge galvanized curtain type in airstream.

CLOSURE SPRINGS (if required)

301 stainless steel constant force type.

FUSIBLE LINK

165°F is standard. 212°F and 285°F available.

DAMPER SIZES

MINIMUM SIZE

Vertical Installation – 4" w x 4" h

Horizontal Installation – 6" w x 6" h

MAXIMUM SIZE

Single-Section

Vertical Installation – 33" w x 36" h

Horizontal Installation – 24" w x 24" h

Multiple-Section

Vertical Installation – 72" w x 48" h, 48" w x 72" h or

90" w x 24" h

Horizontal Installation – 36" w x 48" h

OPTIONS

- **Switch Package** to remotely indicate damper blade position.
- **PFMA** Picture Frame Mounting Angles factory matched and shipped with each damper.
- **Sleeve** of various lengths and gauges to insure field compliance with UL installation requirements.
- **Access Door** factory mounted in common sleeve to ensure compliance with UL installation requirements.
- **Fire Stop Caulk Installation.**
- **FM Approval.**

Model CPD23 meets the requirements for fire dampers established by:

- **National Fire Protection Association** NFPA Standards 90A and 101
- **BOCA National Building Codes**
- **ICBO Uniform Building Codes**
- **SBCCI Standard Building Codes**
- **IBC International Building Codes**
- **CSFM California State Fire Marshal** (consult Lau for complete list of CSFM listed products)

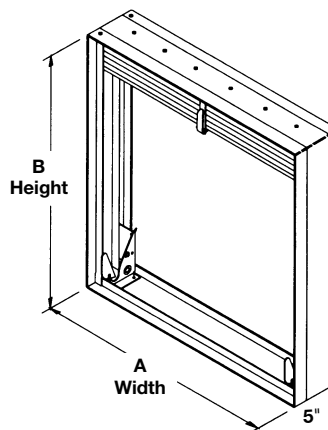

Taped and sealed on vertical sizes up to 33" w x 36" h and horizontal sizes up to 24" w x 24" h.

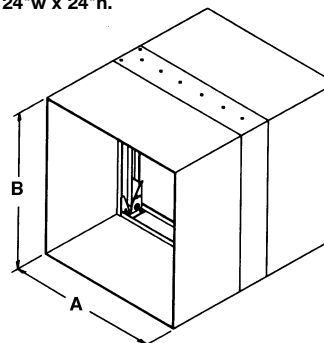

**CPD23 STYLE A
IN FACTORY SLEEVE**

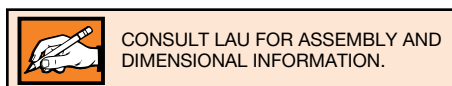

Specifications are subject to change without notice or obligation

CPD23 – STYLE B Blades Out of Airstream 3 Hour Rating

APPLICATION

CPD23 Style B fire dampers can be installed vertically in walls or horizontally in floors with fire resistance ratings of 3 hours or more. The CPD23 carries a 3 hour UL fire damper label and is classified as a dynamic damper for use in HVAC systems that remain in operation during a fire. The CPD23 is rated for dynamic closure to 2,000 fpm and 4 inches w.g. static pressure. Ratings are for in duct and in wall/floor installations with horizontal airflow and vertical airflow, both up and down.

STANDARD CONSTRUCTION

FRAME

20 gauge galvanized, steel channel.

BLADES

24 gauge galvanized curtain type, out of airstream for high free area applications.

CLOSURE SPRINGS (if required)

301 stainless steel constant force type.

FUSIBLE LINK

165°F is standard. 212°F and 285°F available.

DAMPER SIZES

MINIMUM SIZE

Vertical Installation – 6" w x 4" h
Horizontal Installation – 6" w x 4" h

MAXIMUM SIZE

Single-Section
Vertical Installation – 33" w x 32" h
Horizontal Installation – 24" w x 21" h
Multiple-Section
Vertical Installation – 72" w x 45" h, 48" w x 69" h or
90" w x 21" h
Horizontal Installation – 36" w x 42" h

OPTIONS

- **Switch Package** to remotely indicate damper blade position.
- **PFMA** Picture Frame Mounting Angles factory matched and shipped with each damper.
- **Sleeve** of various lengths and gauges to insure field compliance with UL installation requirements.
- **Access Door** factory mounted in common sleeve to ensure compliance with UL installation requirements.
- **Fire Stop Caulk Installation.**
- **FM Approval.**

Model CPD23 meets the requirements for fire dampers established by:

- **National Fire Protection Association** NFPA Standards 90A and 101
- **BOCA National Building Codes**
- **ICBO Uniform Building Codes**
- **SBCCI Standard Building Codes**
- **IBC International Building Codes**
- **CSFM California State Fire Marshal** (consult Lau for complete list of CSFM listed products)

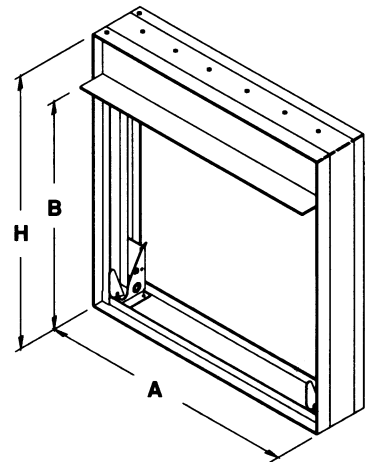

Taped and sealed on vertical sizes up to 33" w x 32" h and horizontal sizes up to 18" w x 21" h.

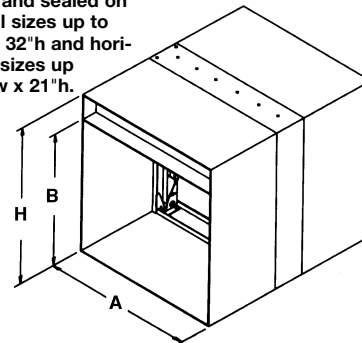

CPD23 Style B IN FACTORY SLEEVE



1. Unit furnished approximately 1/4" smaller than given opening dimensions.
2. Consult Lau for Assembly and Dimensional Information.

Specifications are subject to change without notice or obligation

DYNAMIC FIRE DAMPERS

Use in Dynamic & Static Systems



CPD23 – STYLES R, LR, Round Duct Transition 3 Hour Rating

APPLICATION

CPD23 Styles R and LR fire dampers can be installed vertically in walls or horizontally in floors with fire resistance ratings of 3 hours or more. The CPD23 Styles R and LR carry a 3 hour UL fire damper label and are classified as a dynamic damper for use in HVAC systems that remain in operation during a fire. The **CPD23 Style LR** features a non-sealed round transition for low pressure, 100% free area applications while **Style R** features a non-sealed round transition for low pressure and less than 100% free area applications.

The CPD23 is rated for dynamic closure to 2,000 fpm and 4" w.g. static pressure. Ratings are for in duct wall/floor installations with horizontal airflow and vertical airflow, both up and down.

STANDARD CONSTRUCTION

FRAME

20 gauge galvanized steel channel.

BLADES

24 gauge galvanized curtain type in air stream.

DUCT COLLARS

24 gauge x 2½" long galvanized steel.

CLOSURE SPRINGS (if required)

301 stainless steel constant force type.

FUSIBLE LINK

165°F is standard. 212°F and 285°F available.

DAMPER SIZES

MINIMUM SIZE

Vertical Installation

Styles R, LR – 3" diameter

Horizontal Installation

Styles R, LR – 4" diameter

MAXIMUM SIZE

Single-Section

Vertical Installation

Styles R, LR – 31" diameter

Horizontal Installation

Styles R, LR – 20" diameter

OPTIONS

- **Switch Package** to remotely indicate damper blade position.
- **PFMA** Picture Frame Mounting Angles factory matched and shipped with each damper.
- **Sleeve** of various lengths and gauges to insure field compliance with UL installation requirements.
- **Access Door** factory mounted in common sleeve to ensure compliance with UL installation requirements.
- **Fire Stop Caulk Installation.**
- **FM Approval.**

Model CPD23 meets the requirements for fire dampers established by:

- **National Fire Protection Association NFPA Standards 90A and 101**
- **BOCA National Building Codes**
- **ICBO Uniform Building Codes**
- **SBCCI Standard Building Codes**
- **IBC International Building Codes**
- **CSFM California State Fire Marshal** (consult Lau for complete list of CSFM listed products)

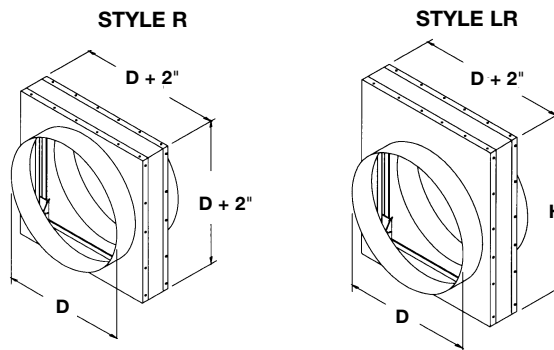

CPD23 STYLE LR IN FACTORY SLEEVE

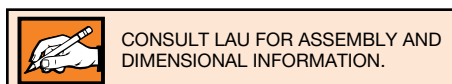
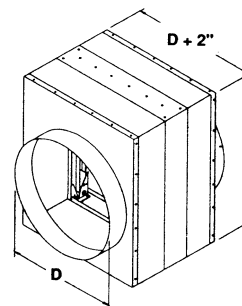

Specifications are subject to change without notice or obligation

CPD25 – STYLE A Integral Sleeve, Blades In Airstream 3 Hour Rating

APPLICATION

The CPD25 Style A can be installed vertically in walls or horizontally in floors with fire resistance ratings of 3 hours or more. The CPD25 carries a 3 hour UL fire damper label and is classified as a dynamic damper for use in HVAC systems that remain in operation during a fire.

The CPD25 is rated for dynamic closure to 2,000 fpm and 4" w.g. static pressure. Ratings are for in duct wall/floor installations with horizontal airflow and vertical airflow, both up and down.

STANDARD CONSTRUCTION

FRAME/SLEEVE

20 gauge x 12" galvanized, steel channel.

BLADES

24 gauge galvanized curtain type in airstream.

CLOSURE SPRINGS (if required)

301 stainless steel constant force type.

FUSIBLE LINK

165°F is standard. 212°F and 285°F available.

DAMPER SIZES

MINIMUM SIZE

Vertical Installation – 4"w x 4"h

Horizontal Installation – 6"w x 6"h

MAXIMUM SIZE

Single Section

Vertical Installation – 33"w x 36"h

Horizontal Installation – 24"w x 24"h

Multiple Section

Vertical Installation – 72"w x 48"h, 48"w x 72"h or

84"w x 24"h,

Horizontal Installation – 36"w x 48"h

OPTIONS

- **Switch Package** to remotely indicate damper blade position.
- **PFMA** Picture Frame Mounting Angles factory matched and shipped with each damper.
- **Access Door** factory mounted in common sleeve to ensure compliance with UL installation requirements.
- **Fire Stop Caulk Installation.**
- **FM Approval.**

Model CPD25 meets the requirements for fire dampers established by:

- **National Fire Protection Association** NFPA Standards 90A and 101
- **BOCA National Building Codes**
- **ICBO Uniform Building Codes**
- **SBCCI Standard Building Codes**
- **IBC International Building Codes**
- **CSFM California State Fire Marshal** (consult Lau for complete list of CSFM listed products)

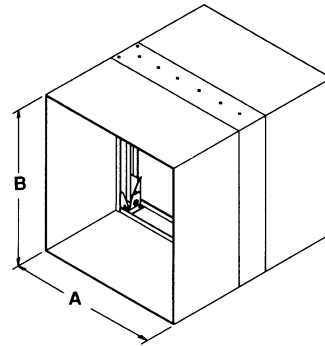

VERTICAL MOUNT

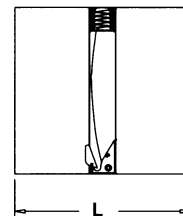

L = Frame/Sleeve Length

HORIZONTAL MOUNT

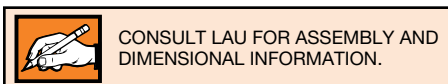
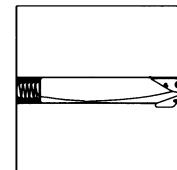

Specifications are subject to change without notice or obligation

DYNAMIC FIRE DAMPERS

Use in Dynamic & Static Systems



CPD25 – STYLE B Integral Sleeve, Blades Out of Airstream 3 Hour Rating

APPLICATION

CPD25 Style B can be installed vertically in walls or horizontally in floors with fire resistance ratings of 3 hours or more. The CPD25 carries a 3 hour UL fire damper label and is classified as dynamic dampers for use in HVAC systems that remain in operation during a fire.

The CPD25 is rated for dynamic closure to 2,000 fpm and 4" w.g. static pressure.

STANDARD CONSTRUCTION

FRAME/SLEEVE

20 gauge x 12" galvanized, steel channel.

BLADES

24 gauge galvanized curtain type in airstream.

CLOSURE SPRINGS (if required)

301 stainless steel constant force type.

FUSIBLE LINK

165°F is standard. 212°F and 285°F available.

DAMPER SIZES

MINIMUM SIZE

Vertical Installation – 6"w x 4"h

Horizontal Installation – 6"w x 4"h

MAXIMUM SIZE

Single-Section

Vertical Installation – 33"w x 32"h

Horizontal Installation – 24"w x 21"h

Multiple-Section

Vertical Installation – 72"w x 45"h, 48"w x 69"h or

84"w x 21"h

Horizontal Installation – 36"w x 42"h

OPTIONS

- **Switch Package** to remotely indicate damper blade position.
- **PFMA** Picture Frame Mounting Angles factory matched and shipped with each damper.
- **Access Door** factory mounted in common sleeve to ensure compliance with UL installation requirements.
- **Fire Stop Caulk Installation.**
- **FM Approval.**

Model CPD25 meets the requirements for fire dampers established by:

- **National Fire Protection Association NFPA Standards 90A and 101**
- **BOCA National Building Codes**
- **ICBO Uniform Building Codes**
- **SBCCI Standard Building Codes**
- **IBC International Building Codes**
- **CSFM California State Fire Marshal** (consult Lau for complete list of CSFM listed products)

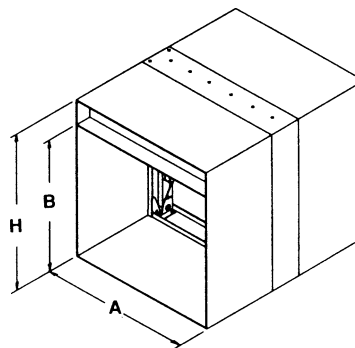

VERTICAL MOUNT

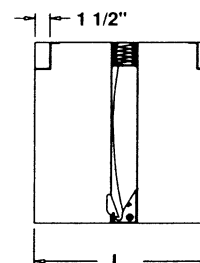

L = Frame/Sleeve Length

HORIZONTAL MOUNT

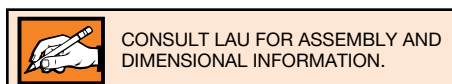
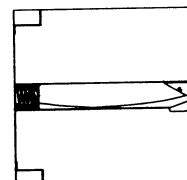

Specifications are subject to change without notice or obligation

CPD25 – STYLES R, LR Integral Sleeve, Round Duct Transition 3 Hour Rating

APPLICATION

CPD25 Styles R and LR fire dampers can be installed vertically in walls or horizontally in floors with fire resistance ratings of 3 hours or more. The CPD25 carries a 3 hour UL fire damper label and is classified as a dynamic damper for use in HVAC systems that remain in operation during a fire. The CPD25 Styles R and LR feature a non-sealed transition for low pressure, 100% free area applications (Style R does not allow 100% free area).

The CPD25 is rated for dynamic closure to 2,000 fpm and 4" w.g. static pressure. Ratings are for in duct wall/floor installations with horizontal airflow and vertical airflow, both up and down.

STANDARD CONSTRUCTION

FRAME/SLEEVE

20 gauge x 12" galvanized, steel channel.

BLADES

24 gauge galvanized curtain type in airstream.

CLOSURE SPRINGS (if required)

301 stainless steel constant force type.

FUSIBLE LINK

165°F is standard. 212°F and 285°F available.

DAMPER SIZES

MINIMUM SIZE

Vertical Installation
Styles R, LR – 3" diameter
Horizontal Installation
Styles R, LR – 4" diameter

MAXIMUM SIZE

Single Section
Vertical Installation
Styles R, LR – 31" diameter
Horizontal Installation
Style R, LR – 20" diameter

OPTIONS

- **Switch Package** to remotely indicate damper blade position.
- **PFMA** Picture Frame Mounting Angles factory matched and shipped with each damper.
- **Access Door** factory mounted in common sleeve to ensure compliance with UL installation requirements.
- **Fire Stop Caulk Installation.**
- **FM Approval.**

Model CPD25 meets the requirements for fire dampers established by:

- **National Fire Protection Association NFPA Standards 90A and 101**
- **BOCA National Building Codes**
- **ICBO Uniform Building Codes**
- **SBCCI Standard Building Codes**
- **IBC International Building Codes**
- **CSFM California State Fire Marshal** (consult Lau for complete list of CSFM listed products)



STYLE R

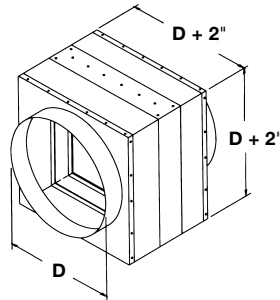

STYLE LR

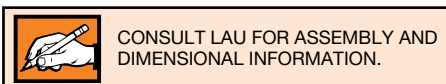
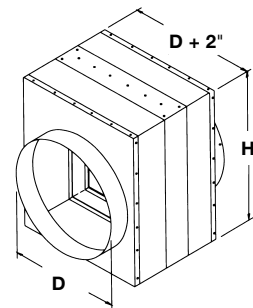

DYNAMIC FIRE DAMPERS

Use in Dynamic & Static Systems



CPD2, CPD23, CPD12, CPD25 – STYLE A

Assembly and Dimensional Information

Dampers normally fabricated approximately 1/4" less than given duct dimensions. A (width) and B (height) dimensions shown describe maximum UL Classified sizes. Lau recommends the authority having jurisdiction, the engineer and the contractor agree on the installation design prior to installation.

CPD2 and CPD23 multiple section dampers ordered without sleeves are shipped in individual sections, for field assembly.

CPD2 and CPD23 multiple section dampers ordered with factory furnished sleeves are normally shipped in complete assemblies.

CPD12 and CPD25 multiple section dampers are shipped in individual sections, for field assembly.

If TDF or other flanged breakaway connections are to be used, order dampers with factory furnished sleeves actual size.

VERTICAL INSTALLATION

IMPORTANT NOTE: Dampers larger than 33" x 36" are multiple section dampers consisting of equal sections no larger than 24" x 24".

Single Section Dampers

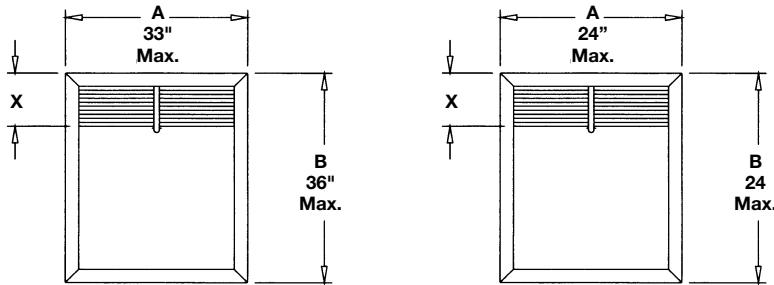

Multiple Section Dampers

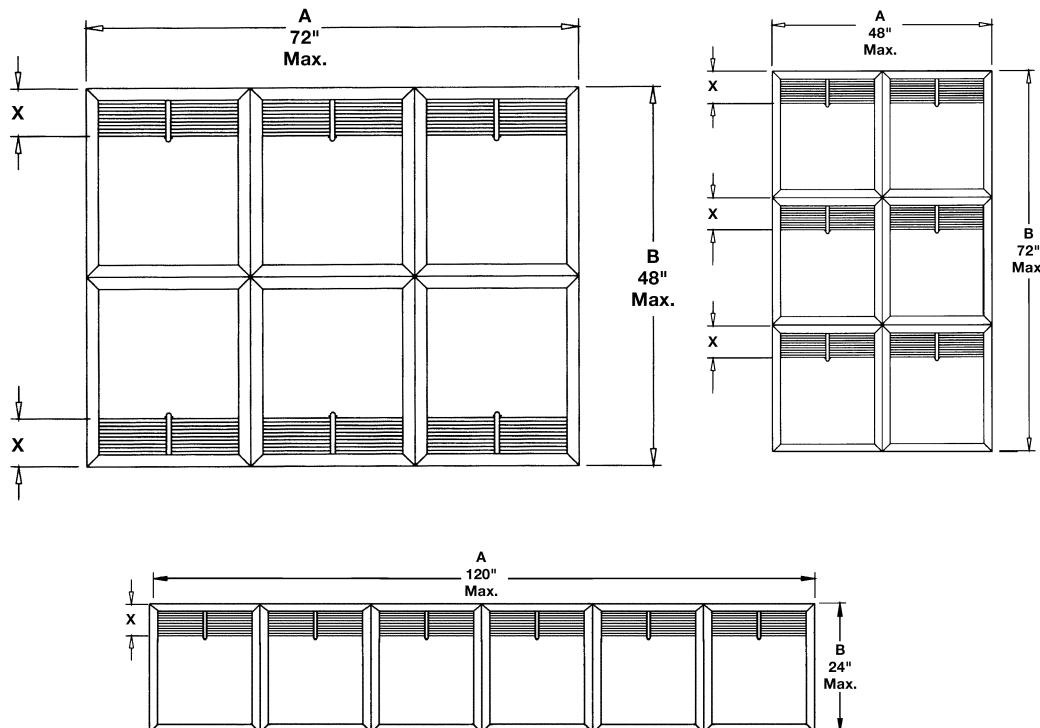

Blade Dimensions	
B	X
6	1½
7	1½
8	1¾
9	1¾
10	1¾
11	2
12	2
13	2⅜
14	2⅝
15	2⅝
16	2⅝
17	2⅝
18	2¾
19	2¾
20	2¾
21	2¾
22	2½
23	2½
24	2½
25	3
26	3
27	3¼
28	3¼
29	3½
30	3½
31	3½
32	3⅝
33	3⅝
34	3⅝
35	3⅝
36	4

Specifications are subject to change without notice or obligation

HORIZONTAL INSTALLATION

IMPORTANT NOTES:

1. Dampers larger than 24" x 24" are multiple section dampers consisting of equal sections no larger than 18" x 24".
2. Dampers larger than 24"w or 24"h have a minimum size of 10"w or 10"h.

Single Section Dampers

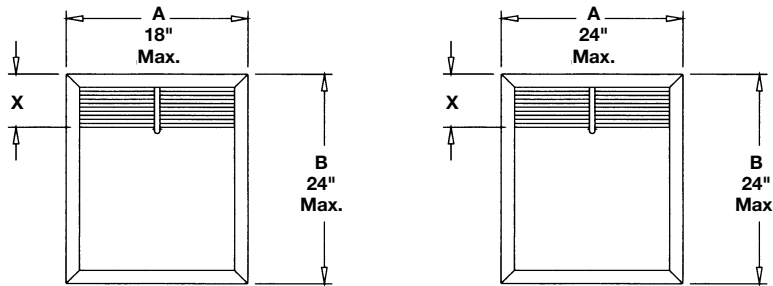

Multiple Section Dampers

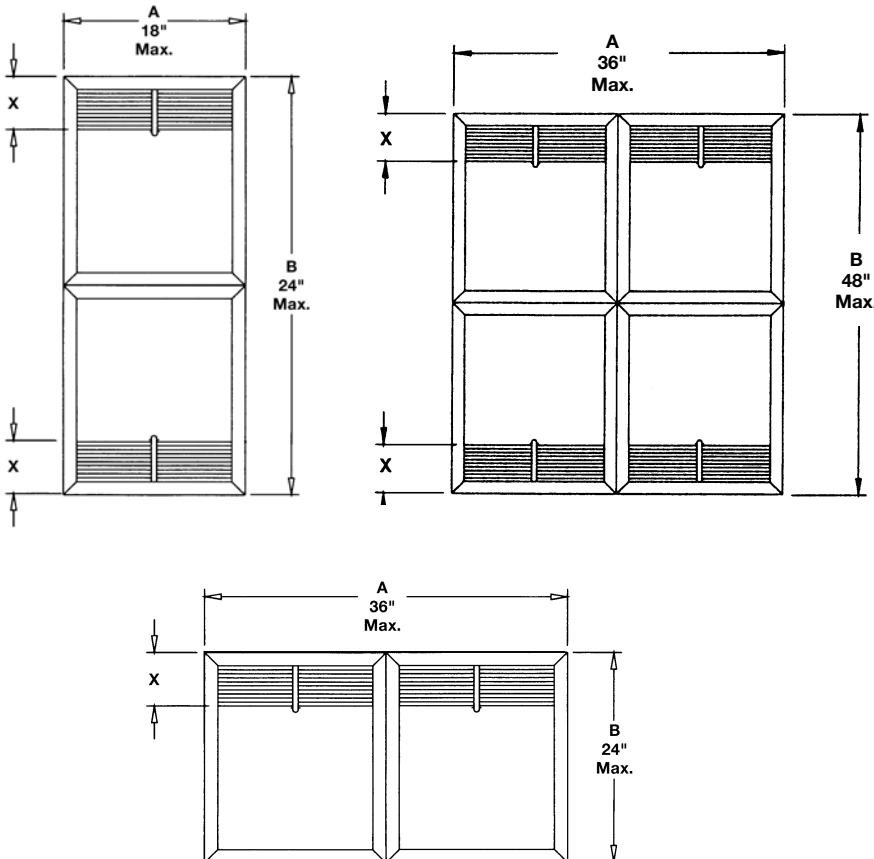

Blade Dimensions	
B	X
6	1½
7	1½
8	1¾
9	1¾
10	1¾
11	2
12	2
13	2
14	2
15	2⅝
16	2⅝
17	2⅝
18	2⅝
19	2⅝
20	2¾
21	2¾
22	3
23	3
24	3

Specifications are subject to change without notice or obligation

DYNAMIC FIRE DAMPERS

Use in Dynamic & Static Systems



CPD2, CPD23, CPD12, CPD25 – STYLE B

Assembly and Dimensional Information

VERTICAL INSTALLATION

IMPORTANT NOTE: Dampers larger than 33" x 32" are multiple section dampers consisting of equal sections no larger than 24" x 24" overall.

To determine the overall height (H dimension) of double high and triple high damper assemblies; add 1 3/4" to B dimension on dampers over 21" through 24" and 2 3/4" to the B dimension on all other dampers.

For Example:

A 24" double high assembly is 25 3/4" overall height. A 65" triple high assembly is 67 3/4" overall height. The bottom sections on double and triple high assemblies are Style A dampers.

Single Section Dampers

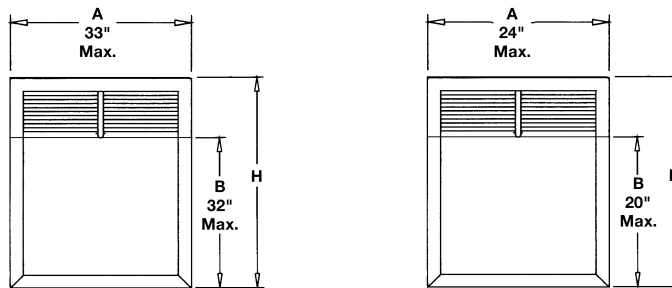

B	H
4	5 3/4
5	6 3/4
6	7 3/4
7	8 3/4
8	9 3/4
9	11 3/4
10	12 3/4
11	13 3/4
12	14 3/4
13	15 3/4
14	16 3/4
15	17 3/4
16	18 3/4
17	20 3/4
18	21 3/4
19	22 3/4
20	23 3/4
21	23 3/4
22	25 3/4
23	26 3/4
24	27 3/4
25	28 3/4
26	29 3/4
27	30 3/4
28	31 3/4
29	32 3/4
30	33 3/4
31	34 3/4
32	35 3/4

Multiple Section Dampers

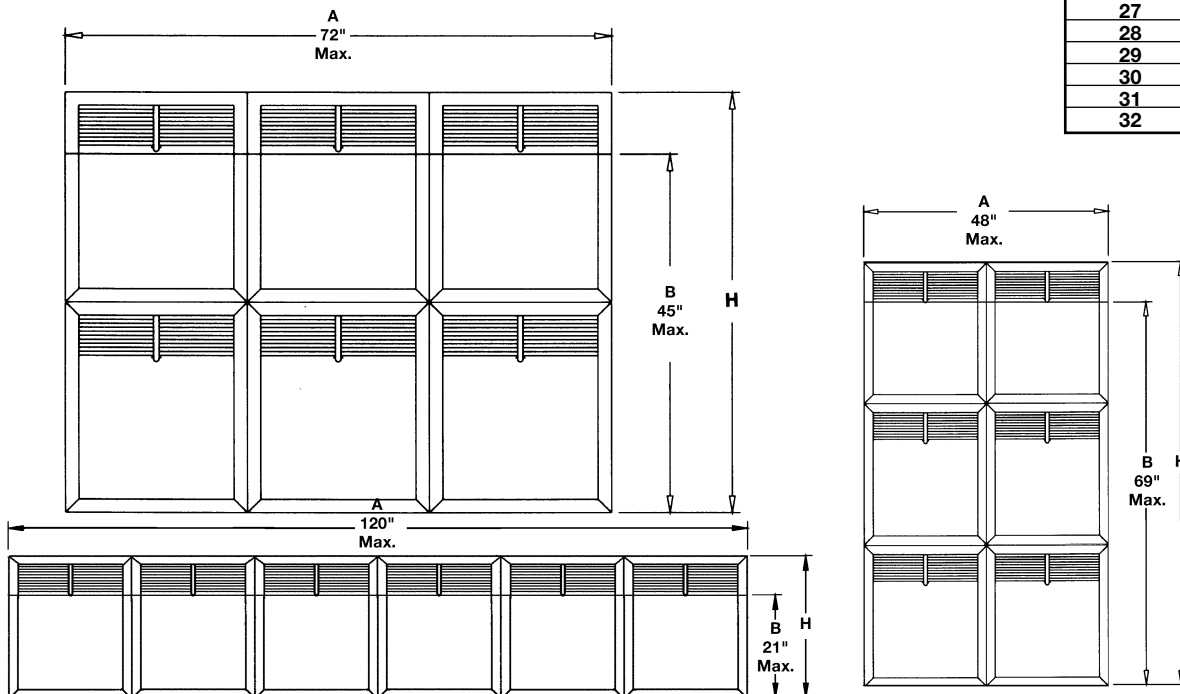

Specifications are subject to change without notice or obligation

CPD2, CPD23, CPD12, CPD25 – STYLE B

Assembly and Dimensional Information

HORIZONTAL INSTALLATION

IMPORTANT NOTE: Dampers larger than 24" x 21" are multiple section dampers consisting of equal sections no larger than 24" x 24" overall.

To determine the overall height (H dimension) of double high damper assemblies; add 3½" to B dimension on dampers over 21" through 25" and 5½" on all other dampers.

For Example:

A damper with a 28" B dimension has an overall height H dimension of 33½".

Single Section Dampers

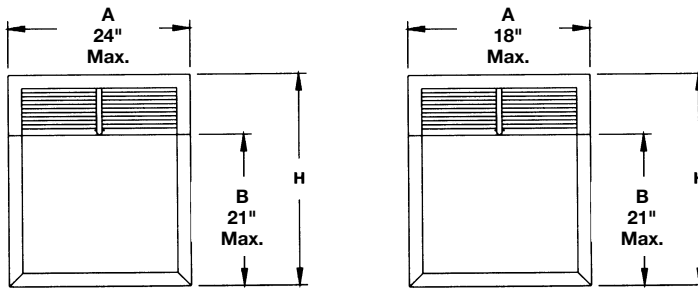

B	H
4	5¼
5	6¼
6	7¼
7	8¼
8	10¼
9	11¼
10	12¼
11	13¼
12	14¼
13	15¼
14	16¼
15	17¼
16	18¼
17	19¼
18	20¼
19	21¼
20	22¼
21	23¼

Multiple Section Dampers

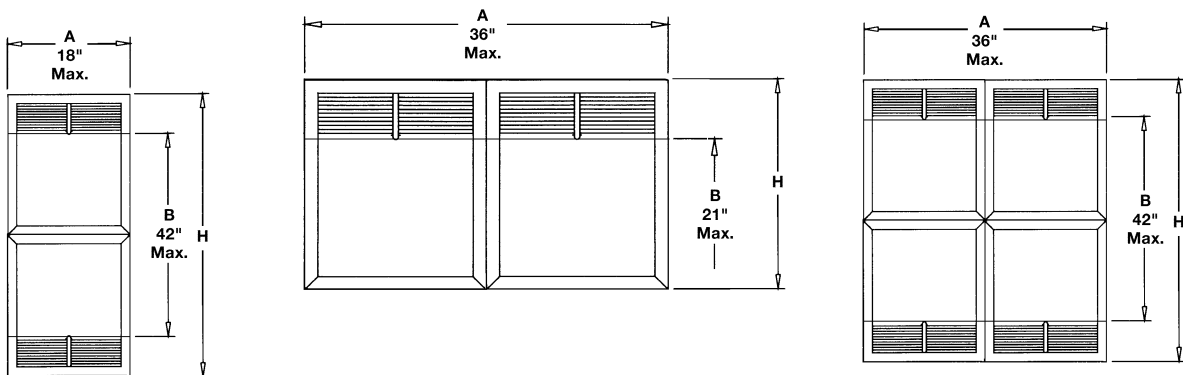

SHIPPING NOTE:

Most Lau products can be shipped normal parcel shipping services, such as FedEx or UPS, but, some products are too large and must be shipped via common carrier.

Next Day or 2nd Day parcel services can be used to ship items special handling costs. Because the majority of items in this catalog are bulky, we recommend checking with our Customer Service Representatives to verify pricing of expedited service.

DYNAMIC FIRE DAMPERS

Use in Dynamic & Static Systems



CPD2, CPD23, CPD12, CPD25 – STYLE LR

Assembly and Dimensional Information

VERTICAL INSTALLATION

IMPORTANT NOTE: Dampers larger than 31" diameter are multiple section dampers consisting of equal sections no larger than 24" x 24" overall.

To determine the overall height (H dimension) of double high damper assemblies; add 3³/₄" to D dimension on dampers.

For Example:

A 40" double high assembly is 43³/₄" overall height. The bottom sections on double high assemblies are Style A dampers with blades in the air stream.

Single Section Dampers

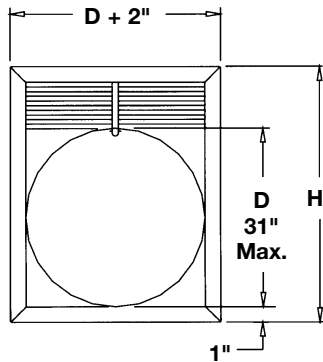

Multiple Section Dampers

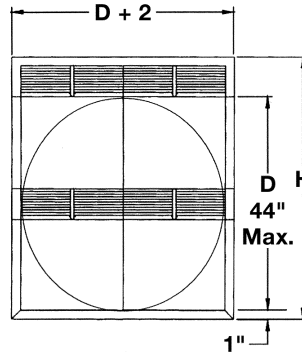

D	H
3	5 ³ / ₄
4	6 ³ / ₄
5	7 ³ / ₄
6	8 ³ / ₄
7	9 ³ / ₄
8	11 ³ / ₄
9	12 ³ / ₄
10	13 ³ / ₄
11	14 ³ / ₄
12	15 ³ / ₄
13	16 ³ / ₄
14	17 ³ / ₄
15	18 ³ / ₄
16	20 ³ / ₄
17	21 ³ / ₄
18	22 ³ / ₄
19	23 ³ / ₄
20	23 ³ / ₄
21	25 ³ / ₄
22	26 ³ / ₄
23	27 ³ / ₄
24	28 ³ / ₄
25	29 ³ / ₄
26	30 ³ / ₄
27	31 ³ / ₄
28	32 ³ / ₄
29	33 ³ / ₄
30	34 ³ / ₄
31	35 ³ / ₄

HORIZONTAL INSTALLATION

IMPORTANT NOTE: Dampers larger than 20" diameter are multiple section dampers consisting of equal sections no larger than 18" x 24" overall.

To determine the overall height (H dimension) of double high damper assemblies; add 3¹/₂" to D dimension on dampers over 20" through 25" and 5¹/₂" on all other sizes.

For Example:

A 24" double high assembly is 27¹/₂" overall height.

Single Section Dampers

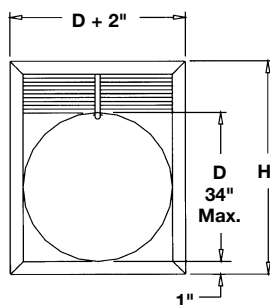

Multiple Section Dampers

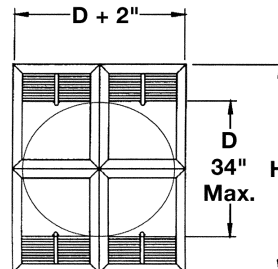

D	H
3	5 ³ / ₄
4	6 ³ / ₄
5	7 ³ / ₄
6	8 ³ / ₄
7	10 ³ / ₄
8	11 ³ / ₄
9	12 ³ / ₄
10	13 ³ / ₄
11	14 ³ / ₄
12	15 ³ / ₄
13	16 ³ / ₄
14	17 ³ / ₄
15	18 ³ / ₄
16	19 ³ / ₄
17	20 ³ / ₄
18	21 ³ / ₄
19	22 ³ / ₄
20	23 ³ / ₄

Specifications are subject to change without notice or obligation

CP2 – STYLE A Blades In Airstream 1½ Hour Rating

APPLICATION

CP2 Style A fire dampers can be installed vertically in walls or horizontally in floors with fire resistance ratings of less than 3 hours. The CP2 carries a 1½ hour UL fire damper label and is classified as a static damper for use in HVAC systems that shut down during a fire.

STANDARD CONSTRUCTION

FRAME

20 gauge galvanized steel channel.

BLADES

24 gauge galvanized curtain type in air stream.

FINISH

Mill.

CLOSURE SPRINGS (Horizontal Mount Only)

301 stainless steel constant force type.

FUSIBLE LINK

165°F is standard. 212°F and 285°F available.

DAMPER SIZES

MOUNTING

Vertical or Horizontal.

MINIMUM SIZE

Vertical Installation – 4" w x 4" h

Horizontal Installation – 6" w x 6" h

MAXIMUM SIZE

Vertical Installation – 120" w x 72" h

Horizontal Installation – 114" w x 38" h or 90" w x 91" h

OPTIONS

- **Factory Furnished Sleeves** of various lengths and gauges to insure field compliance with UL installation requirements.
- **PFMA** Picture Frame Mounting Angles factory matched and shipped with each damper.
- **FAST Angle** for one side angle installations.
- **G Style** for grille applications.
- **Switch Package.**
- **FM Approval.**

Model CP2 meets the requirements for fire dampers established by:

- **National Fire Protection Association** NFPA Standards 90A and 101
- **BOCA National Building Codes**
- **ICBO Uniform Building Codes**
- **SBCCI Standard Building Codes**
- **IBC International Building Codes**
- **CSFM California State Fire Marshal** (consult Lau for complete list of CSFM listed products)

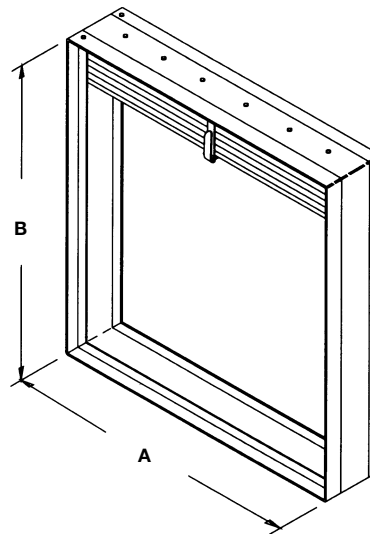

VERTICAL MOUNT

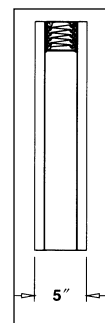

HORIZONTAL MOUNT

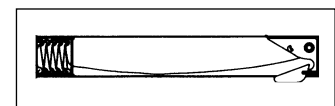

1. Dampers furnished approximately 1/4" smaller than given duct dimensions.
2. For dynamic (fans on) systems, see model CPD2.
3. Consult Lau for Assembly and Dimensional Information.

STATIC FIRE DAMPERS

Use in Static Systems Only



CP2 – STYLE B

Blades Out of Airstream

1½ Hour Rating

APPLICATION

CP2 Style B fire dampers can be installed vertically in walls or horizontally in floors with fire resistance ratings of less than 3 hours. The CP2 carries a 1½ hour UL fire damper label and is classified as a static damper for use in HVAC systems that shut down during a fire.

STANDARD CONSTRUCTION

FRAME

20 gauge galvanized steel channel.

BLADES

24 gauge galvanized curtain type. Blades out of air stream for minimum air flow restriction.

FINISH

Mill.

CLOSURE SPRINGS (Horizontal Mount Only)

301 stainless steel constant force type.

FUSIBLE LINK

165°F is standard. 212°F and 285°F available.

DAMPER SIZES

MOUNTING

Vertical or Horizontal.

MINIMUM SIZE

Vertical Installation – 4"w x 4"h

Horizontal Installation – 6"w x 4"h

MAXIMUM SIZE

Vertical Installation – 120"w x 65"h

Horizontal Installation – 114"w x 33"h or 90"w x 81"h

OPTIONS

- **Factory Furnished Sleeves** of various lengths and gauges to insure field compliance with UL installation requirements.
- **PFMA** Picture Frame Mounting Angles factory matched and shipped with each damper.
- **FAST Angle** for one side angle installations.
- **Switch Package.**
- **FM Approval.**

Model CP2 meets the requirements for fire dampers established by:

- **National Fire Protection Association** NFPA Standards 90A and 101
- **BOCA National Building Codes**
- **ICBO Uniform Building Codes**
- **SBCCI Standard Building Codes**
- **IBC International Building Codes**
- **CSFM California State Fire Marshal** (consult Lau for complete list of CSFM listed products)

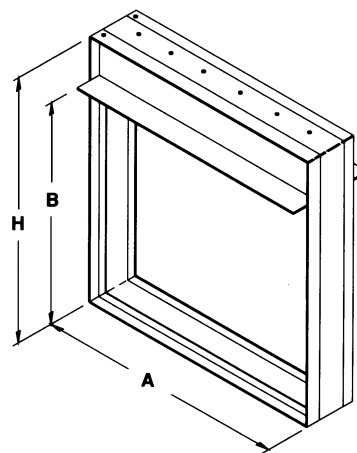

VERTICAL MOUNT

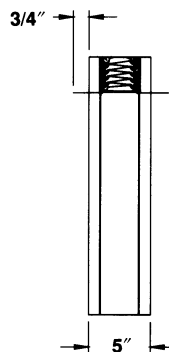

HORIZONTAL MOUNT

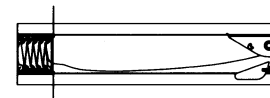

- 
1. A & B dimensions furnished approximately 1/4" smaller than given duct dimensions.
 2. For dynamic (fans on) systems, see model CPD2.
 3. Consult Lau for Assembly and Dimensional Information.

Specifications are subject to change without notice or obligation

CP2 – STYLES R, LR Round Duct Transition 1½ Hour Rating

APPLICATION

CP2 Styles R and LR fire dampers can be installed vertically in walls or horizontally in floors with fire resistance ratings of less than 3 hours. The CP2 carries a 1½ hour UL fire damper label and is classified as a static damper for use in HVAC systems that shut down during a fire. The CP2 **Style LR** features a non-sealed round transition for low pressure, 100% free area applications while **Style R** features a non-sealed round transition for low pressure and less than 100% free area applications.

STANDARD CONSTRUCTION

FRAME

20 gauge galvanized steel channel.

BLADES

24 gauge galvanized curtain type.
Style R – Blades partially in air stream.
Styles LR – Blades out of air stream.

DUCT COLLARS

24 gauge x 2½" long galvanized steel.

FINISH

Mill.

CLOSURE SPRINGS (Horizontal Mount Only)

301 stainless steel constant force type.

FUSIBLE LINK

165°F is standard. 212°F and 285°F available.

DAMPER SIZES

MINIMUM SIZE

Vertical or Horizontal Installation
Styles R, LR – 4" diameter

MAXIMUM SIZE

Vertical or Horizontal Installation
Styles R, LR – 31" diameter

OPTIONS

- **Factory Furnished Sleeves** of various lengths and gauges to insure field compliance with UL installation requirements.
- **PFMA** Picture Frame Mounting Angles factory matched and shipped with each damper.
- **FAST Angle** for one side angle installations.
- **Switch Package.**
- **FM Approval.**

Model CP2 meets the requirements for fire dampers established by:

- **National Fire Protection Association** NFPA Standards 90A and 101
- **BOCA National Building Codes**
- **ICBO Uniform Building Codes**
- **SBCCI Standard Building Codes**
- **IBC International Building Codes**
- **CSFM California State Fire Marshal** (consult Lau for complete list of CSFM listed products)



STYLE R

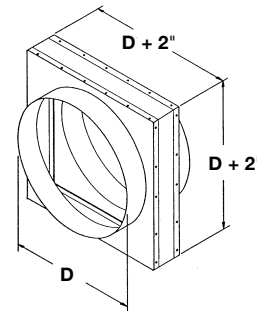

STYLE LR

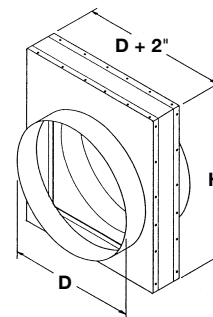

1. Duct collars are furnished approximately 1/8" smaller than given duct dimensions.
2. For dynamic (fans on) systems, see model CPD2.
3. Consult Lau for Assembly and Dimensional Information.

STATIC FIRE DAMPERS

Use in Static Systems Only



CP2 – STYLE G

Grille Mount

1½ Hour Rating

APPLICATION

CP2 Style G curtain type fire dampers can be installed vertically in walls or horizontally in floors with fire resistance ratings of less than 3 hours. Style G curtain type fire dampers are offset in a sleeve with 3/4" grille mounting flanges. The damper and sleeve assembly fits flush in the wall or floor opening and the customer supplied steel frame grille installs over and completely conceals the mounting flanges. For other types and applications, refer to the GA type fire dampers.

STANDARD CONSTRUCTION

FRAME

20 gauge galvanized steel channel.

BLADES

24 gauge galvanized curtain type in air stream.

CLOSURE SPRINGS (if required)

301 stainless steel constant force type.

FUSIBLE LINK

165°F is standard. 212°F and 285°F available.

DAMPER SIZES

MOUNTING

Vertical or Horizontal.

MINIMUM SIZE

Vertical Installation – 4"w x 4"h

Horizontal Installation – 6"w x 6"h

MAXIMUM SIZE

Vertical Installation – 49"w x 32"h or 32"w x 49"h

Horizontal Installation – 24"w x 18"h or 18"w x 24"h

OPTIONS

- **Switch Package** to remotely indicate damper blade position.
- **PFMA** Picture Frame Mounting Angles factory matched and shipped with each damper.
- **GA, Grille Access Type** for "out of the wall" and no angle grille applications.
- **Sleeve** of various lengths and gauges to insure field compliance with UL installation requirements.
- **Access Door** factory mounted in common sleeve to ensure compliance with UL installation requirements.
- **FM Approval.**



1. Damper/sleeve assemblies furnished actual size.
2. For dynamic (fans on) systems, see model CPD2 Style G.
3. Consult Lau for Assembly and Dimensional Information.

Model CP2 meets the requirements for fire dampers established by:

- **National Fire Protection Association NFPA Standards 90A and 101**
- **BOCA National Building Codes**
- **ICBO Uniform Building Codes**
- **SBCCI Standard Building Codes**
- **IBC International Building Codes**
- **CSFM California State Fire Marshal** (consult Lau for complete list of CSFM listed products)



SEE COMPLETE MARKING ON PRODUCT

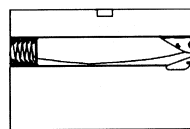
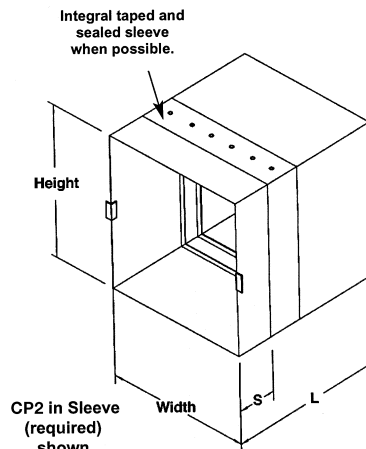

HORIZONTAL

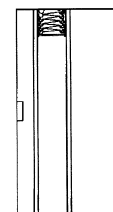

VERTICAL

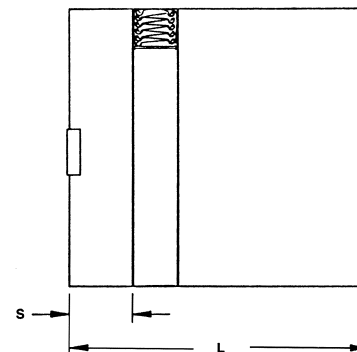

HOW TO APPLY

1. Size the damper (A x B).
2. Determine the set back dimension (S). See note 1.
3. Calculate sleeve length (L). See note 2.
4. Install the damper per the UL approved installation instructions. See note 3.

NOTES:

1. CP2 G must be ordered with a sleeve and is available with a standard S dimension of 2 3/4". Other set back dimensions are available and must be specified.
2. To calculate sleeve length (L), determine wall, floor or ceiling thickness and add 3" minimum.
For example: A 6" wall would require a minimum 9" sleeve. This would allow 3" of sleeve opposite the grille for retaining angles and duct connections.
3. If damper will be "out of wall," refer to CP2GA or consult Lau.
4. For no angle installation or installation from one side of wall, consult Lau.

Specifications are subject to change without notice or obligation

CPT Thinline

1½ Hour Rating

APPLICATION

CPT is a thinline fire damper that can be installed vertically in walls or horizontally in floors with fire resistance ratings of less than 3 hours. The CPT carries a 1½ hour UL fire damper label and is classified as a static damper for use in HVAC systems that shut down during a fire.

STANDARD CONSTRUCTION

FRAME

- 20 gauge galvanized steel.
- CPT - 3½" with easy mounting flanges.
- CPT1 - 2½" with mounting flange one side.
- CPT2 - 2½" no flange.

BLADES

24 gauge ultra slim galvanized steel curtain type.

FINISH

Mill.

FUSIBLE LINK

165°F is standard. 212°F and 285°F available.

DAMPER SIZES

MOUNTING

Vertical or Horizontal.

MINIMUM SIZE

Vertical Installation – 4"w x 4"h
Horizontal Installation – 6"w x 6"h

MAXIMUM SIZE

Single-Section
Vertical Installation – 40"w x 48"h
Horizontal Installation – 60"w x 12"h

OPTIONS

- **Factory Furnished Sleeves** of various lengths and gauges to insure field compliance with UL installation requirements.
- **PFMA** Picture Frame Mounting Angles factory matched and shipped with each damper.
- **FAST Angle** for one side angle installations.
- **G Style** for grille applications.
- **Switch Package.**
- **Fire Stop Caulk Installation.**
- **FM Approval.**

Model CPT meets the requirements for fire dampers established by:

- **National Fire Protection Association** NFPA Standards 90A and 101
- **BOCA National Building Codes**
- **ICBO Uniform Building Codes**
- **SBCCI Standard Building Codes**
- **IBC International Building Codes**
- **CSFM California State Fire Marshal** (consult Lau for complete list of CSFM listed products)

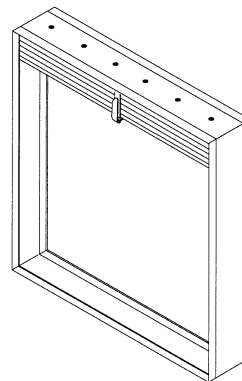

CPT Style A

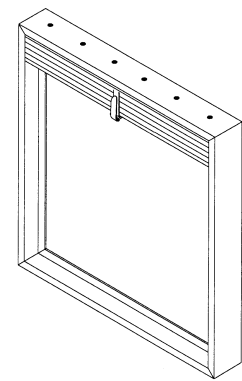

CPT1 Style A

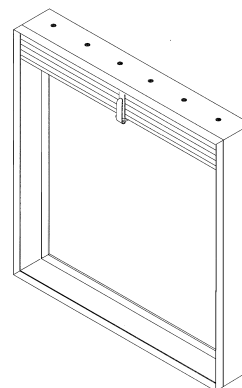

CPT2 Style A

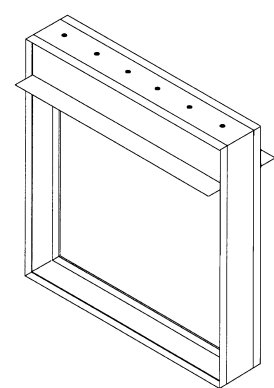

CPT Style B



1. Dampers furnished approximately 1/4" smaller than given duct dimensions.
2. For dynamic (fans on) systems, see model CPDT.
3. Consult Lau for Assembly and Dimensional Information.

Specifications are subject to change without notice or obligation

STATIC FIRE DAMPERS

Use in Static Systems Only



CPT

Thinline

1½ Hour Rating

STYLE A DIMENSIONS

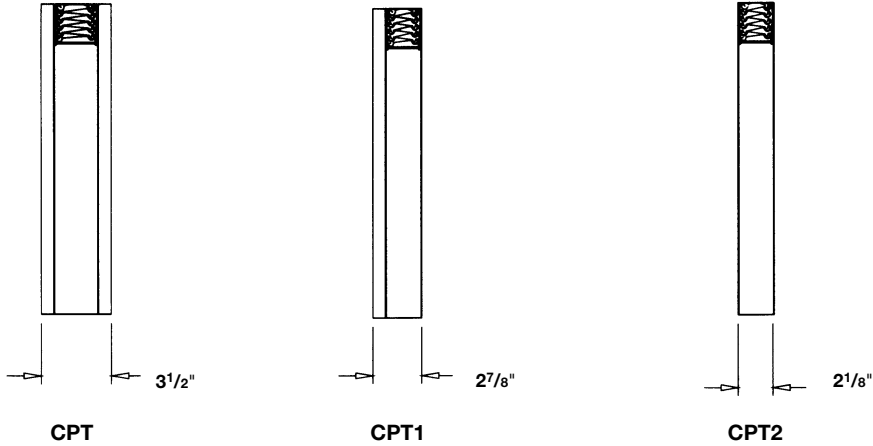

B	X
4	1 5/8
5	1 7/8
6	1 7/8
7	2
8	2 1/4
9	2 1/2
10	2 3/4
11	3
12	3 1/4
13	3 1/2
14	3 1/2
15	3 3/8
16	3 3/8
17	4 1/8
18	4 3/8
19	4 3/8
20	4 3/8
21	5
22	5 1/4
23	5 1/4
24	5 1/2
25	5 3/4
26	5 3/8
27	6 1/8
28	6 1/8
29	6 3/8
30	6 3/8
31	7
32	7
33	7 1/4
34	7 1/2
35	7 3/4
36	8
37	8 1/8
38	8 3/8
39	8 3/8
40	8 3/8
41	8 3/8
42	9
43	9 1/4
44	9 1/2
45	9 3/4
46	10
47	10 1/4
48	10 3/8

STYLE B DIMENSIONS

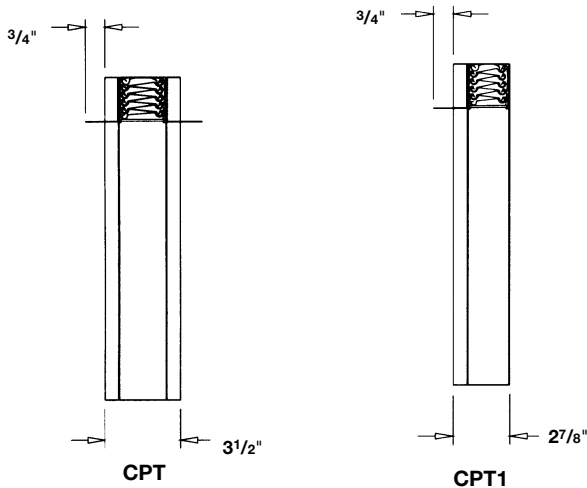

B	H
4	5 1/4
5	6 1/4
6	7 1/4
7	8 1/4
8	10 1/4
9	11 1/4
10	12 1/4
11	13 1/4
12	14 1/4
13	16 1/4
14	17 1/4
15	18 1/4
16	20 1/4
17	21 1/4
18	22 1/4
19	23 1/4
20	24 1/4
21	26 1/4
22	27 1/4
23	28 1/4
24	30 1/4
25	31 1/4
26	32 1/4
27	33 1/4
28	34 1/4
29	36 1/4
30	37 1/4
31	38 1/4
32	39 1/4
33	40 1/4
34	42 1/4
35	43 1/4
36	44 1/4
37	45 1/4
38	47 1/4

Specifications are subject to change without notice or obligation

C12 – STYLE A Integral Sleeve, Blades In Airstream 1½ Hour Rating

APPLICATION

C12 Style A fire dampers can be installed vertically in walls or horizontally in concrete floors with fire resistance ratings of less than 3 hours. The C12 carries a 1½ hour UL fire damper label and is classified as a static damper for use in HVAC systems that shut down during a fire.

STANDARD CONSTRUCTION

INTEGRAL SLEEVE FRAME

20 gauge galvanized steel. Not air tight.
Length 12"

BLADES

24 gauge galvanized curtain type in air stream.

FINISH

Mill.

CLOSURE SPRINGS (Horizontal Mount Only)

301 stainless steel constant force type.

FUSIBLE LINK

165°F is standard. 212°F and 285°F available.

DAMPER SIZES

MOUNTING

Vertical or Horizontal.

MINIMUM SIZE

Vertical Installation – 4"w x 4"h
Horizontal Installation – 6"w x 6"h

MAXIMUM SIZE

Vertical Installation – 84"w x 72"h
Horizontal Installation – 84"w x 84"h

OPTIONS

- **PFMA** two-piece picture Frame Mounting Angles (requires factory sleeve).
- **G Style** for grille applications.
- **Factory Hem** for S and Drivemate duct sleeve connection.
- **Fully Sealed Sleeves.**
- **Switch Package.**
- **Fire Stop Caulk Installation.**
- **FM Approval.**

Model C12 meets the requirements for fire dampers established by:

- **National Fire Protection Association NFPA Standards 90A and 101**
- **BOCA National Building Codes**
- **ICBO Uniform Building Codes**
- **SBCCI Standard Building Codes**
- **IBC International Building Codes**
- **CSFM California State Fire Marshal** (consult Lau for complete list of CSFM listed products)

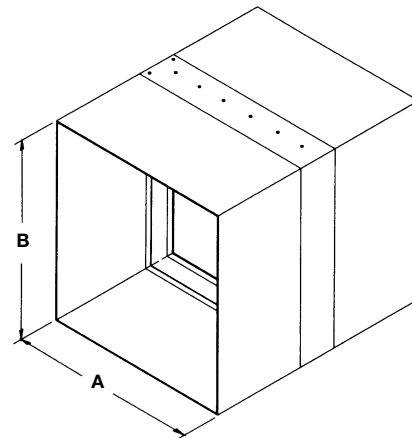

VERTICAL MOUNT

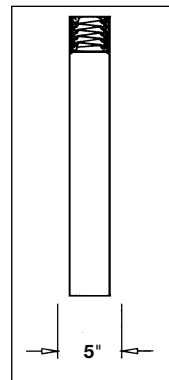

HORIZONTAL MOUNT

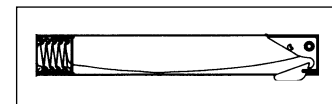

1. Dampers furnished approximately 1/4" smaller than given duct dimensions.
2. For dynamic (fans on) systems, see model CPD12
3. Consult Lau for Assembly and Dimensional Information.

STATIC FIRE DAMPERS

Use in Static Systems Only



C12 – STYLE B

Integral Sleeve, Blades Out of Airstream

1½ Hour Rating

APPLICATION

C12 Style B fire dampers can be installed vertically in walls or horizontally in concrete floors with fire resistance ratings of less than 3 hours. The C12 carries a 1½ hour UL fire damper label and is classified as a static damper for use in HVAC systems that shut down during a fire.

STANDARD CONSTRUCTION

INTEGRAL SLEEVE FRAME

20 gauge galvanized steel. Not air tight.
Length 12"

BLADES

24 gauge galvanized curtain type. Blades out of air stream for minimum air flow restriction.

FINISH

Mill.

CLOSURE SPRINGS (Horizontal Mount Only)

301 stainless steel constant force type.

FUSIBLE LINK

165°F is standard. 212°F and 285°F available.

DAMPER SIZES

MOUNTING

Vertical or Horizontal.

MINIMUM SIZE

Vertical Installation – 4"w x 4"h
Horizontal Installation – 6"w x 4"h

MAXIMUM SIZE

Vertical Installation – 84"w x 65"h
Horizontal Installation – 84"w x 74"h

OPTIONS

- **PFMA** two-piece picture Frame Mounting Angles (requires factory sleeve).
- **Factory Hem** for S and Drivemate duct sleeve connection.
- **Fully Sealed Sleeves.**
- **Switch Package.**
- **Fire Stop Caulk Installation.**
- **FM Approval.**

Model C12 meets the requirements for fire dampers established by:

- **National Fire Protection Association** NFPA Standards 90A and 101
- **BOCA National Building Codes**
- **ICBO Uniform Building Codes**
- **SBCCI Standard Building Codes**
- **IBC International Building Codes**
- **CSFM California State Fire Marshal** (consult Lau for complete list of CSFM listed products)

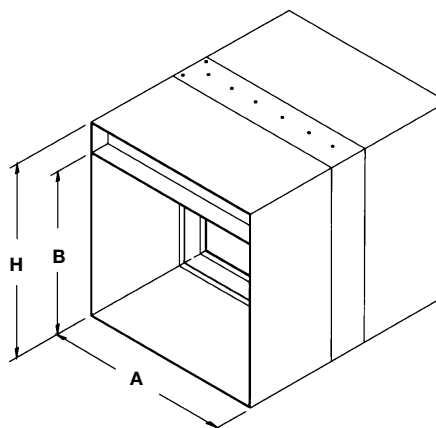

VERTICAL MOUNT

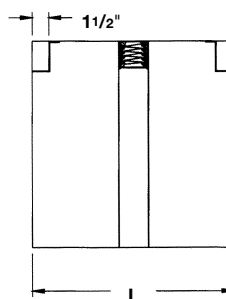

HORIZONTAL MOUNT

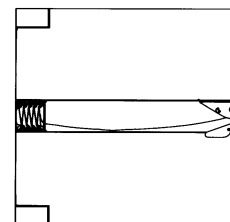

1. A & B dimensions furnished approximately 1/4" smaller than given duct dimensions.
2. For dynamic (fans on) systems, see model CPD12.
3. Consult Lau for Assembly and Dimensional Information.

Specifications are subject to change without notice or obligation

C12 – STYLES R, LR Integral Sleeve, Round Duct Transition 1½ Hour Rating

APPLICATION

C12 Styles R and LR fire dampers can be installed vertically in walls or horizontally in concrete floors with fire resistance ratings of less than 3 hours. The C12 carries a 1½ hour UL fire damper label and is classified as a static damper for use in HVAC systems that shut down during a fire. The C12 **Style LR** features a non-sealed round transition for low pressure, 100% free area applications while **Style R** features a non-sealed round transition for low pressure and less than 100% free area applications.

STANDARD CONSTRUCTION

FRAME

20 gauge galvanized steel out of air stream. Not air tight.

BLADES

24 gauge galvanized curtain type.
Style R – Blades partially in air stream.
Styles LR – Blades out of air stream.

DUCT COLLARS

24 gauge x 2½" long galvanized steel. Not air tight.

FINISH

Mill.

CLOSURE SPRINGS (Horizontal Mount Only)

301 stainless steel constant force type.

FUSIBLE LINK

165°F is standard. 212°F and 285°F available.

DAMPER SIZES

MOUNTING

Vertical or Horizontal.

MINIMUM SIZE

Vertical or Horizontal Installation
Styles R, LR – 4" diameter

MAXIMUM SIZE

Vertical or Horizontal Installation
Styles R, LR – 31" diameter

OPTIONS

- **PFMA** Picture Frame Mounting Angles factory matched and shipped with each damper.
- **Fully Sealed Sleeves.**
- **Switch Package.**
- **Fire Stop Caulk Installation.**
- **FM Approval.**

Model CP12 meets the requirements for fire dampers established by:

- **National Fire Protection Association NFPA Standards 90A and 101**
- **BOCA National Building Codes**
- **ICBO Uniform Building Codes**
- **SBCCI Standard Building Codes**
- **IBC International Building Codes**
- **CSFM California State Fire Marshal** (consult Lau for complete list of CSFM listed products)

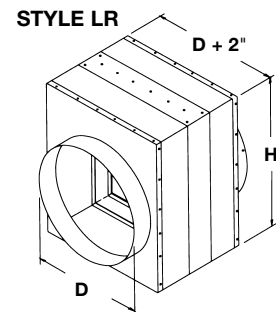
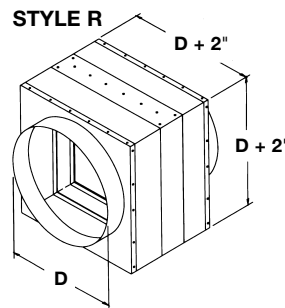

HORIZONTAL MOUNT

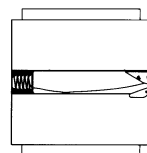

VERTICAL MOUNT

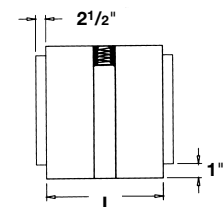

1. Dampers furnished approximately 1/4" smaller than given duct dimensions.
2. For dynamic (fans on) systems, see model CPD12
3. Consult Lau for Assembly and Dimensional Information.

STATIC FIRE DAMPERS

Use in Static Systems Only



CP23 – STYLE A Blades In Airstream 3 Hour Rating

APPLICATION

CP23 Style A fire dampers can be installed vertically in walls or horizontally in floors with fire resistance ratings of 3 hours or more. The CP23 carries a 3 hour UL fire damper label and is classified as a static damper for use in HVAC systems that shut down during a fire.

STANDARD CONSTRUCTION

FRAME

20 gauge galvanized steel channel.

BLADES

24 gauge galvanized curtain type in air stream.

FINISH

Mill.

CLOSURE SPRINGS (if required)

301 stainless steel constant force type.

FUSIBLE LINK

165°F is standard. 212°F and 285°F available.

DAMPER SIZES

MOUNTING

Vertical or Horizontal.

MINIMUM SIZE

Vertical Installation – 4"w x 4"h

Horizontal Installation – 6"w x 6"h

MAXIMUM SIZE

Vertical Installation – 90"w x 72"h

Horizontal Installation – 90"w x 91"h

OPTIONS

- **Factory Furnished Sleeves** of various lengths and gauges to insure field compliance with UL installation requirements.
- **PFMA** two-piece picture frame mounting angles (requires factory sleeve).
- **FAST Angle** for one side angle installations.
- **Switch Package.**
- **Fire Stop Caulk Installation.**
- **FM Approval.**

Model CP23 meets the requirements for fire dampers established by:

- **National Fire Protection Association** NFPA Standards 90A and 101
- **BOCA National Building Codes**
- **ICBO Uniform Building Codes**
- **SBCCI Standard Building Codes**
- **IBC International Building Codes**
- **CSFM California State Fire Marshal** (consult Lau for complete list of CSFM listed products)

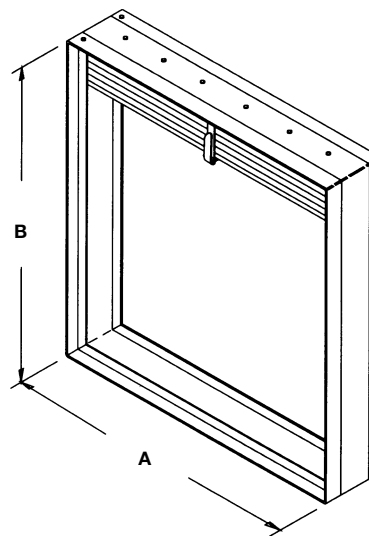

VERTICAL MOUNT

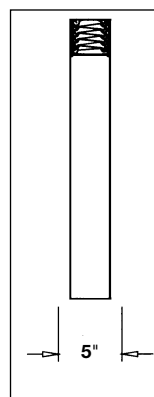

HORIZONTAL MOUNT

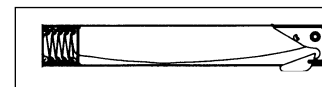

1. Dampers furnished approximately 1/4" smaller than given duct dimensions.
2. For dynamic (fans on) systems, see model CPD23
3. Consult Lau for Assembly and Dimensional Information.

Specifications are subject to change without notice or obligation

CP23 – STYLE B Blades Out of Airstream 3 Hour Rating

APPLICATION

CP23 Style B fire dampers can be installed vertically in walls or horizontally in concrete floors with fire resistance ratings of 3 hours or more. The CP23 carries a 3 hour UL fire damper label and is classified as a static damper for use in HVAC systems that shut down during a fire.

STANDARD CONSTRUCTION

FRAME

20 gauge galvanized steel channel.

BLADES

24 gauge galvanized curtain type. Blades out of air stream for minimum air flow restriction.

FINISH

Mill.

CLOSURE SPRINGS (if required)

301 stainless steel constant force type.

FUSIBLE LINK

165°F is standard. 212°F and 285°F available.

DAMPER SIZES

MOUNTING

Vertical or Horizontal.

MINIMUM SIZE

Vertical Installation – 4"w x 4"h

Horizontal Installation – 6"w x 4"h

MAXIMUM SIZE

Vertical Installation – 99"w x 68"h

Horizontal Installation – 90"w x 81"h

OPTIONS

- **Factory Furnished Sleeves** of various lengths and gauges to insure field compliance with UL installation requirements.
- **PFMA** two-piece picture frame mounting angles (requires factory sleeve).
- **FAST Angle** for one side angle installations.
- **Switch Package**.
- **FM Approval**.

Model CP23 meets the requirements for fire dampers established by:

- **National Fire Protection Association NFPA Standards 90A and 101**
- **BOCA National Building Codes**
- **ICBO Uniform Building Codes**
- **SBCCI Standard Building Codes**
- **IBC International Building Codes**
- **CSFM California State Fire Marshal** (consult Lau for complete list of CSFM listed products)

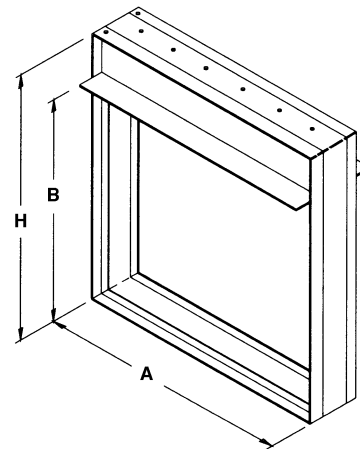

VERTICAL MOUNT

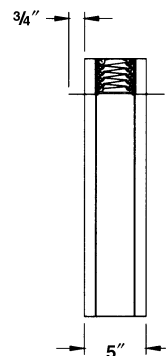

HORIZONTAL MOUNT

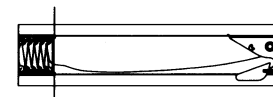

1. A & B dimensions furnished approximately 1/4" smaller than given duct dimensions.
2. For dynamic (fans on) systems, see model CPD23.
3. Consult Lau for Assembly and Dimensional Information.

Specifications are subject to change without notice or obligation

STATIC FIRE DAMPERS

Use in Static Systems Only



CP23 – STYLES R, LR Round Duct Transition 3 Hour Rating

APPLICATION

CP23 Styles R and LR fire dampers can be installed vertically in walls or horizontally in floors with fire resistance ratings of three hours or more. The CP23 carries a 3 hour UL fire damper label and is classified as a static damper for use in HVAC systems that shut down during a fire. The CP23 **Style LR** features a non-sealed round transition for low pressure, 100% free area applications while **Style R** features a non-sealed round transition for low pressure and less than 100% free area applications.

STANDARD CONSTRUCTION

FRAME

20 gauge galvanized steel channel.

BLADES

24 gauge galvanized curtain type.
Style R – Blades partially in air stream.
Style LR – Blades out of air stream.

DUCT COLLARS

24 gauge x 2 1/2" long galvanized steel. Not air tight.

FINISH

Mill.

CLOSURE SPRINGS (if required)

301 stainless steel constant force type.

FUSIBLE LINK

165°F is standard. 212°F and 285°F available.

DAMPER SIZES

MOUNTING

Vertical or Horizontal.

MINIMUM SIZE

Vertical or Horizontal Installation
Styles R, LR – 4" diameter

MAXIMUM SIZE

Single Section, Vertical Installation
Styles R, LR – 31" diameter
Single Section, Horizontal Installation
Styles R, LR – 28" diameter

OPTIONS

- **Factory Furnished Sleeves** of various lengths and gauges to insure field compliance with UL installation requirements.
- **PFMA** Picture Frame Mounting Angles factory matched and shipped with each damper.
- **FAST** Angle for one side angle installations.
- **Switch Package.**
- **Fire Stop Caulk Installation.**
- **FM Approval.**

Model CP23 meets the requirements for fire dampers established by:

- **National Fire Protection Association** NFPA Standards 90A and 101
- **BOCA National Building Codes**
- **ICBO Uniform Building Codes**
- **SBCCI Standard Building Codes**
- **IBC International Building Codes**
- **CSFM California State Fire Marshal** (consult Lau for complete list of CSFM listed products)



STYLE R

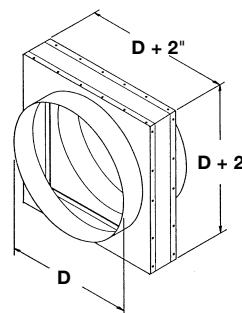

STYLE LR

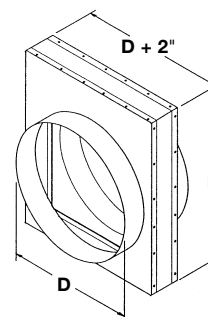

1. Duct collars furnished approximately 1/8" smaller than given duct dimensions.
2. For dynamic (fans on) systems, see model CPD23.
3. Consult Lau for Assembly and Dimensional Information.

Specifications are subject to change without notice or obligation

CP25 – STYLE A Integral Sleeve, Blades In Airstream 3 Hour Rating

APPLICATION

CP25 Style A fire dampers can be installed vertically in walls or horizontally in concrete floors with fire resistance ratings of 3 hours. The CP25 carries a 3 hour UL fire damper label and is classified as a static damper for use in HVAC systems that shut down during a fire.

STANDARD CONSTRUCTION

INTEGRAL SLEEVE FRAME

20 gauge galvanized steel. Not air tight.
Length 12"

BLADES

24 gauge galvanized curtain type in air stream.

FINISH

Mill.

CLOSURE SPRINGS (if required)

301 stainless steel constant force type.

FUSIBLE LINK

165°F is standard. 212°F and 285°F available.

DAMPER SIZES

MOUNTING

Vertical or Horizontal.

MINIMUM SIZE

Vertical Installation – 4"w x 4"h
Horizontal Installation – 6"w x 6"h

MAXIMUM SIZE

Single Section
Vertical Installation – 36"w x 36"h
Horizontal Installation – 30"w x 45"h
Multiple Section
Vertical Installation – 84"w x 72"h
Horizontal Installation – 84"w x 84"h

OPTIONS

- **Factory Hem** for S and Drivemate duct sleeve connection.
- **Fully Sealed Sleeves.**
- **Switch Package.**
- **Fire Stop Caulk Installation.**
- **FM Approval.**

Model CP25 meets the requirements for fire dampers established by:

- **National Fire Protection Association NFPA Standards 90A and 101**
- **BOCA National Building Codes**
- **ICBO Uniform Building Codes**
- **SBCI Standard Building Codes**
- **IBC International Building Codes**
- **CSFM California State Fire Marshal** (consult Lau for complete list of CSFM listed products)

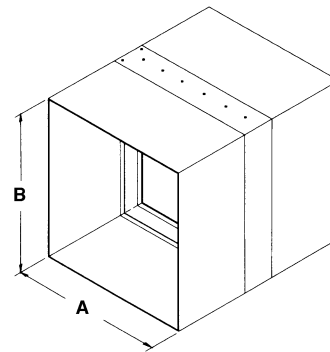

VERTICAL MOUNT

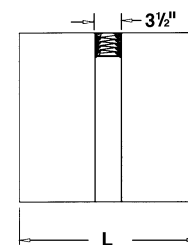

L = INTEGRAL FRAME/SLEEVE LENGTH

HORIZONTAL MOUNT

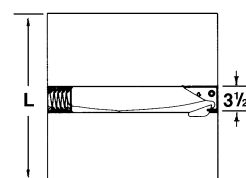

1. Dampers furnished approximately 1/4" smaller than given duct dimensions.
2. For dynamic (fans on) systems, see model CPD25.
3. Consult Lau for Assembly and Dimensional Information.

STATIC FIRE DAMPERS

Use in Static Systems Only



CP25 – STYLE B

Integral Sleeve, Blades Out of Airstream

3 Hour Rating

APPLICATION

CP25 Style B fire dampers can be installed vertically in walls or horizontally in concrete floors with fire resistance ratings of 3 hours. The CP25 carries a 3 hour UL fire damper label and is classified as a static damper for use in HVAC systems that shut down during a fire.

STANDARD CONSTRUCTION

INTEGRAL SLEEVE FRAME

20 gauge galvanized steel. Not air tight.
Length 12"

BLADES

24 gauge galvanized curtain type. Blades out of air stream for minimum air flow restriction.

FINISH

Mill.

CLOSURE SPRINGS (if required)

301 stainless steel constant force type.

FUSIBLE LINK

165°F is standard. 212°F and 285°F available.

DAMPER SIZES

MOUNTING

Vertical or Horizontal.

MINIMUM SIZE

Vertical Installation – 4"w x 4"h
Horizontal Installation – 6"w x 4"h

MAXIMUM SIZE

Single Section
Vertical Installation – 36"w x 32"h
Horizontal Installation – 30"w x 40"h
Multiple Section
Vertical Installation – 84"w x 68"h
Horizontal Installation – 84"w x 74"h

OPTIONS

- **Factory Hem** for S and Drivemate duct sleeve connection.
- **Fully Sealed Sleeves.**
- **Switch Package.**
- **Fire Stop Caulk Installation.**
- **FM Approval.**

Model CP25 meets the requirements for fire dampers established by:

- **National Fire Protection Association NFPA Standards 90A and 101**
- **BOCA National Building Codes**
- **ICBO Uniform Building Codes**
- **SBCCI Standard Building Codes**
- **IBC International Building Codes**
- **CSFM California State Fire Marshal** (consult Lau for complete list of CSFM listed products)

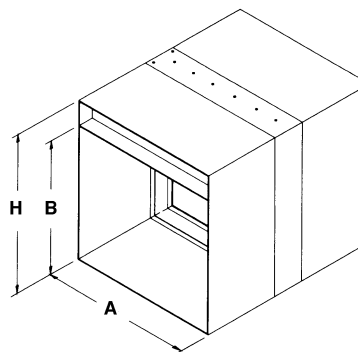

VERTICAL MOUNT

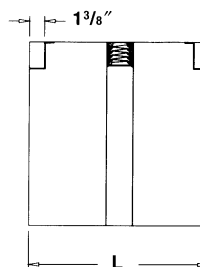

HORIZONTAL MOUNT

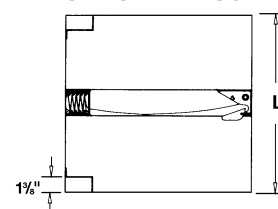

L = INTEGRAL STEEL FRAME LENGTH



1. A & B dimensions furnished approximately 1/4" smaller than given duct dimensions.
2. For dynamic (fans on) systems, see model CPD25.
3. Consult Lau for Assembly and Dimensional Information.

Specifications are subject to change without notice or obligation

CP25 – STYLES R, LR Integral Sleeve, Round Duct Transition 3 Hour Rating

APPLICATION

CP25 Styles R and LR fire dampers can be installed vertically in walls or horizontally in concrete floors with fire resistance ratings of 3 hours. The CP25 carries a 3 hour UL fire damper label and is classified as a static damper for use in HVAC systems that shut down during a fire. The CP25 **Style LR** features a non-sealed round transition for low pressure, 100% free area applications while **Style R** features a non-sealed round transition for low pressure and less than 100% free area applications.

STANDARD CONSTRUCTION

INTEGRAL SLEEVE FRAME

20 gauge galvanized steel out of air stream. Not air tight.
Length 12"

BLADES

24 gauge galvanized curtain type.
Style R – Blades partially in air stream.
Style LR – Blades out of air stream.

DUCT COLLARS

24 gauge x 2½" long galvanized steel. Not air tight.

FINISH

Mill.

CLOSURE SPRINGS (if required)

301 stainless steel constant force type.

FUSIBLE LINK

165°F is standard. 212°F and 285°F available.

DAMPER SIZES

MOUNTING

Vertical or Horizontal.

MINIMUM SIZE

Vertical or Horizontal Installation
Styles R, LR – 3" diameter

MAXIMUM SIZE

Single Section, Vertical Installation
Styles R, LR – 31" diameter
Single Section, Horizontal Installation
Styles R, LR – 28" diameter

OPTIONS

- Fully Sealed Sleeves.
- Switch Package.
- Fire Stop Caulk Installation.
- PFMA Approval.
- Access Door.
- FM Approval.

Model CP25 meets the requirements for fire dampers established by:

- National Fire Protection Association NFPA Standards 90A and 101
- BOCA National Building Codes
- ICBO Uniform Building Codes
- SBCCI Standard Building Codes
- IBC International Building Codes
- CSFM California State Fire Marshal (consult Lau for complete list of CSFM listed products)

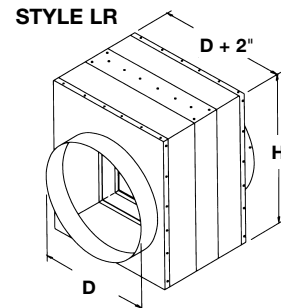
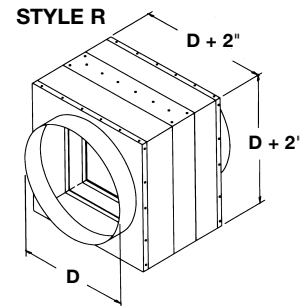

1. Duct collars furnished approximately 1/8" smaller than given duct dimensions.
2. For dynamic (fans on) systems, see model CPD25.
3. Consult Lau for Assembly and Dimensional Information.

CEILING RADIATION DAMPERS

General information



INSTALLATION

Refer to Lau Installation Instructions for required installation procedures.

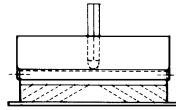

Ductless Installation

Order "actual size" with **standard** frame.
Damper installs over diffuser neck.

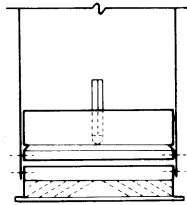

Steel Duct Installation

Order "deduct" 1/4" with **standard** frame.
Damper installs inside duct.

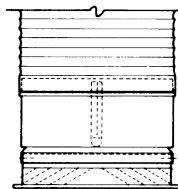

Flex Duct Installation

Order "actual size" with **extended** frame.
Damper installs over diffuser neck; flex duct installs over damper.

Pressure Drop – Damper Open (Size as noted)

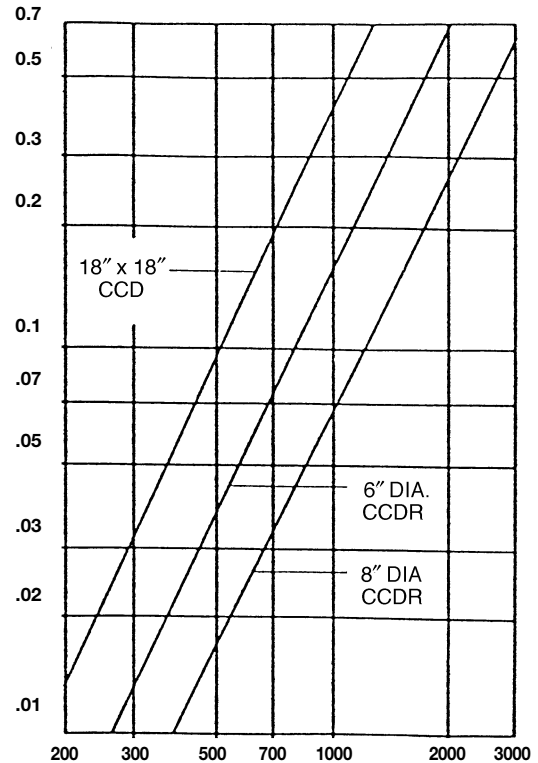

Air Velocity in FEET per minute through FACE AREA.
Tested per AMCA Std. 500, Fig. 5.2, duct work upstream.

VARIATIONS

UL Listed Fusible Volume Adjustment

The standard, fusible link can be replaced with a simple mechanism that permits adjustment of damper blades to balance airflow. A standard 3/16" hex (Allen) wrench is used for adjustment. In fire conditions, the damper closes regardless of volume setting. **This feature must be added to the damper at fabrication – it cannot be field added.** 165°F and 212°F (specify temperature) fusible volume adjustment options are available.

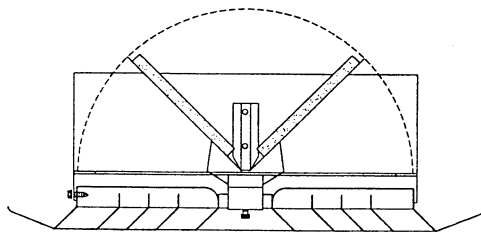

CCD/CCDR with Fusible Volume Adjustment

Specifications are subject to change without notice or obligation

CCD/CCDR
Surface Mount
UL555C Classified

APPLICATION

UL Fire Rated Floor/Ceiling assemblies and Roof/Ceiling assemblies require specially tested and classified ceiling dampers (also called Ceiling Fire Dampers or Radiation Dampers) to provide fire and heat protection where HVAC components penetrate the ceiling membrane. **Standard, 1½ hour primary fire dampers DO NOT provide the necessary protection.**

CCD and CCDR are UL Classified to provide protection to HVAC penetrations of up to 324 sq. in. maximum opening size through UL fire rated assemblies with fire resistance ratings of 3 hours or less for penetrations larger than 324 sq. in. and up to 576 sq. in. The quantity and frequency of permissible HVAC ceiling penetrations are described in the UL Fire Resistance Directory.

WOOD TRUSS CEILING APPLICATION

CCD and CCDR Ceiling Fire Dampers are also UL approved for use in ceiling design L555. L555 is constructed from 2 x 4 wood trusses and are similar to ceiling designs L528, L521, L534, L546, L555, etc. The CCD or CCDR must be installed in insulated steel duct drop in accordance with the manufactures installation instructions provided with the dampers.

STANDARD CONSTRUCTION

FRAME

20 gauge galvanized steel. Frame depths are as shown in following chart.

DAMPER MODEL	FRAME STYLE	B DIMENSION or D DIAMETER	FRAME DEPTH
CCD	Standard	All sizes	3"
	Extended	4" to 10"	6 ⁷ / ₈ "
		11" to 14" 15" to 24"	8 ⁹ / ₁₆ " 11 ⁹ / ₁₆ "
CCDR	Standard	All sizes	3 ¹ / ₂ "
	Extended	5" to 10"	6 ⁷ / ₈ "
		11" to 14" 15" to 20"	6 ⁷ / ₈ " 11 ¹ / ₂ "

BLADE

20 gauge galvanized steel, with UL Classified insulation as required.

FUSIBLE LINK

165°F is standard. 212°F and 285°F is available at no additional cost.

FINISH

Mill.

DAMPER SIZES

MINIMUM SIZE (Inside Dimension)

CCD – 5" w x 4" h
 CCDR – 5" diameter

MAXIMUM SIZE (Inside Dimension)

CCD – 324 sq. in. with height or width dimensions not greater than 24"
 CCDR – 20" diameter

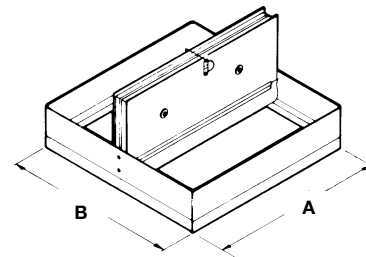

CCD

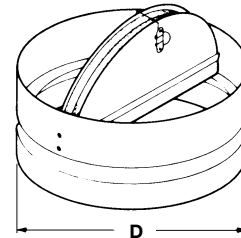

CCDR

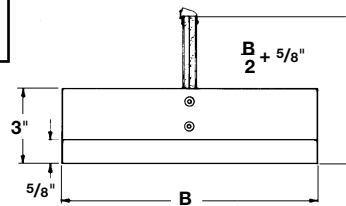

Standard Frame

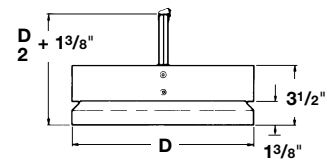

Standard Frame

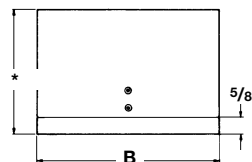

Extended Frame

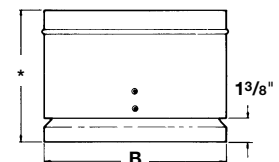

Extended Frame



CONSULT LAU FOR ASSEMBLY AND DIMENSIONAL INFORMATION.

Specifications are subject to change without notice or obligation

CEILING RADIATION DAMPERS



CCD7

WHOLESALE ONLY

The highest quality radiation damper available **ONLY** to Wholesalers.



Through Ceiling Membrane Penetration

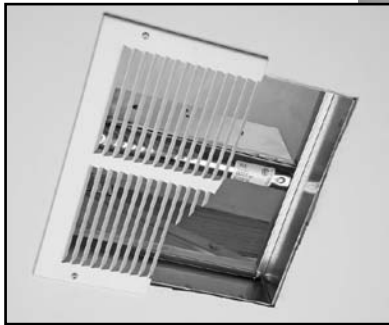

Return Air Plenum (ductless)



Straight Boot

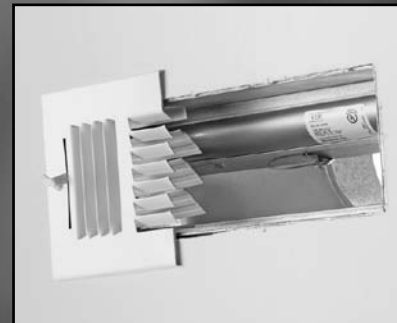

90° Boot

Light commercial installations demand heavy duty, UL listed radiation dampers.

- **UL listed for any installation.**
- **Use your own boot or box, or order pre-assembled.**
- **Shipping in 5 days from 9 locations.**

Features Include:

- **Ductless Return Air Plenum**
- **Straight, End or 90° Boot**
- **Through Ceiling Membrane Penetration**
- **Ductboard or Steel Insulated Plenum Box**



Specifications are subject to change without notice or obligation

CCD7 & CCD7-T Wood Truss Applications UL 555C Classified

APPLICATION

The Lau CCD7 series of ceiling fire dampers maintain the integrity of fire resistive ceiling assemblies constructed from nominal 2 x 10 wood joists or nominal 2 x 4 wood trusses. Use the CCD7 for joist applications and the CCD7-T for truss applications.

CCD7

The CCD7 must be factory or field installed in an insulated steel box (minimum 24 gauge) no taller than 8 $\frac{3}{4}$ ". The insulation is provided by the factory and is shipped loose for field installation. When the box is factory supplied the damper is placed to accommodate a grille depth of 1 $\frac{1}{2}$ ". Refer to **Page 142** for detail of box and refer to the CCD7 installation instructions for appropriate installation details.

CCD7-T

The CCD7-T has been successfully tested in wood truss UL ceiling design L528. The resulting ceiling design number, provided by UL, is L586. The CCD7-T does not require additional damper insulation or boot/box enclosures to meet UL approved installation requirements. The CCD7-T is also UL approved for installation with duct connection below the membrane penetration.

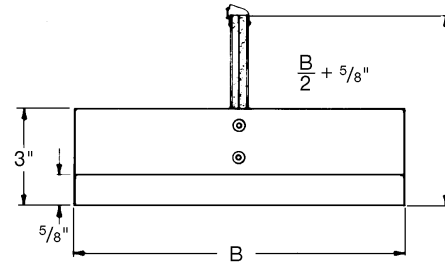
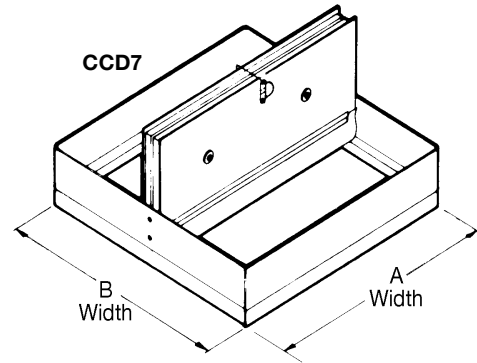

STANDARD CONSTRUCTION

FRAME

20 gauge galvanized steel.

BLADE

20 gauge galvanized steel, with UL classified insulation as required.

FUSIBLE LINK

165°F is standard. 212°F is available at no additional cost.

MINIMUM SIZE (DAMPER SIZES)

CCD7 – 5"w x 4"h
CCD7-T – 5"w x 4"h

MAXIMUM SIZE (DAMPER SIZES)

CCD7 – 16"w x 12"h
CCD7-T – 18"w x 18"h

CCD7-T OPTIONS

- Non-Insulated Steel Box
- Non-Insulated End, Top or 90° Boots
- R4, R6, or R8 Insulated Box
- Through Penetration Extensions

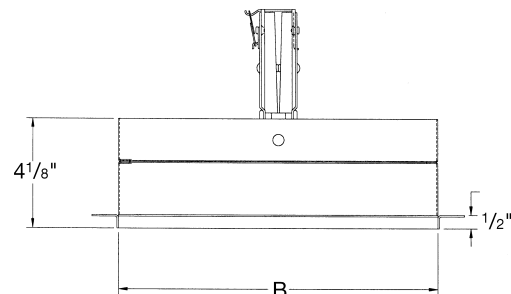
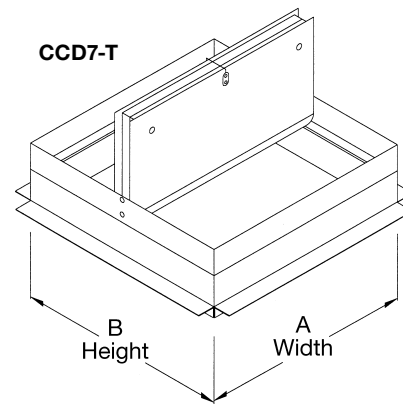

CEILING RADIATION DAMPERS



CCD7 & CCD7-T
Wood Truss Applications
 UL 555C Classified

CCD7-T ENCLOSURE OPTIONS

Non-Insulated Steel Box

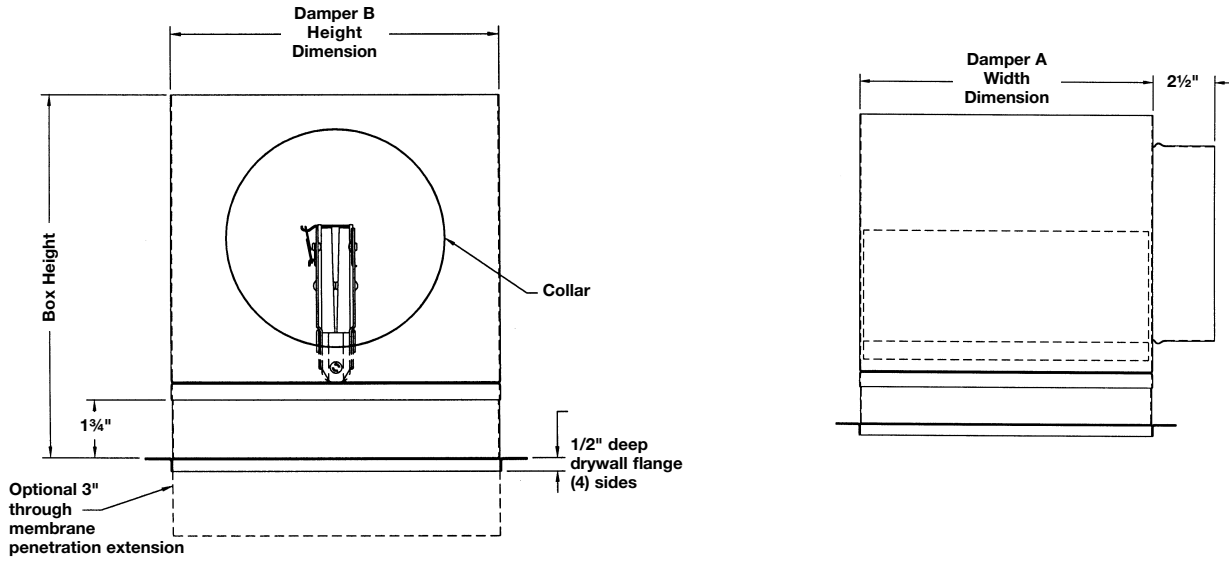

R4, R6 or R8 Insulated Box

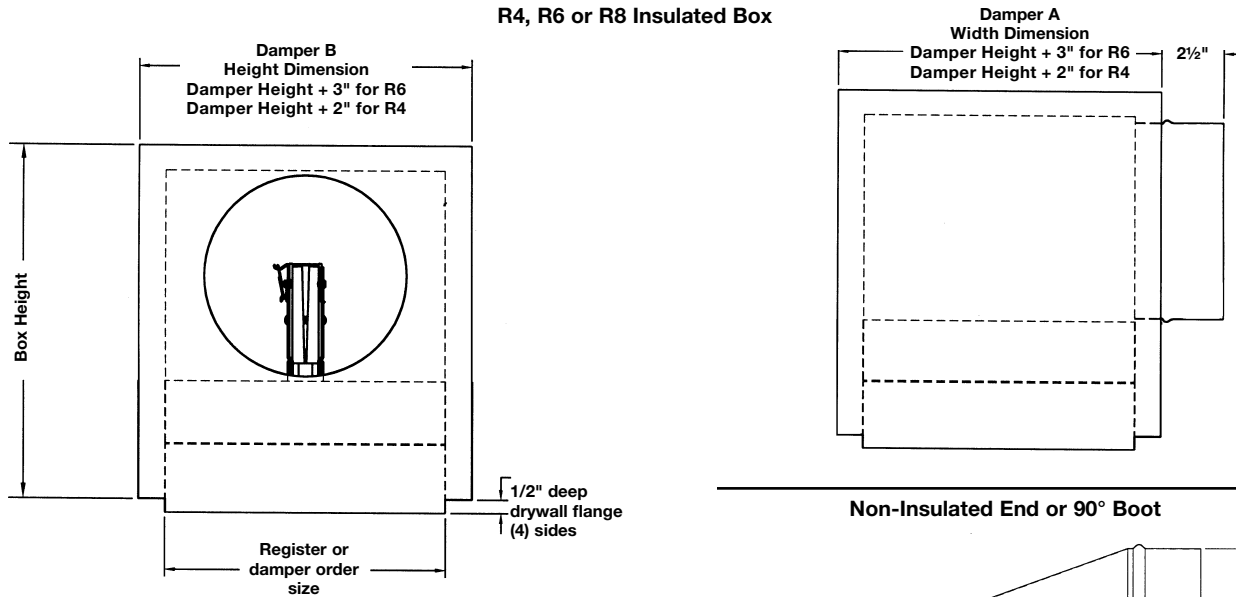

Non-Insulated End or 90° Boot

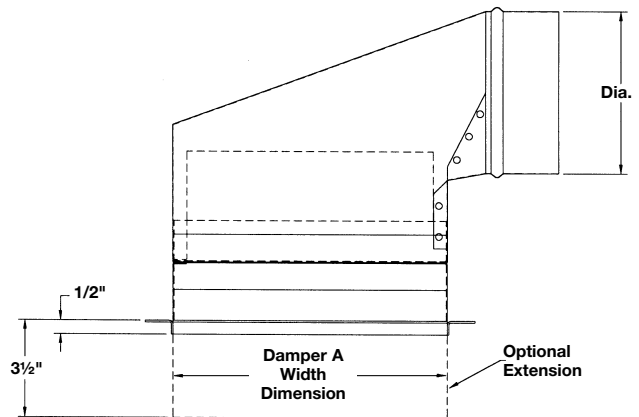

Specifications are subject to change without notice or obligation



CEILING RADIATION DAMPERS

CCD7 & CCD7-T Wood Truss Applications UL 555C Classified

UL FLOOR TO CEILING COMPARISON CHART

The chart below compares the construction of ceiling design L586 to other popular ceiling designs. L586 is a derivative of ceiling design L528 as are the other ceiling designs listed in the chart. Only the more important components of the ceiling design like trusses, subflooring, etc. are included in the comparison. Other minor components like optional vapor barriers, optional floor mat material, etc. are not included in the chart. Complete component listings can be found in the UL Fire Resistance Directory.

The chart shows that L586 is essentially the same as all the other ceiling designs listed. That means the Lau CCD7-T can install in the other ceiling designs (upon approval by the authority having jurisdiction) without negatively affecting the fire resistance rating of the ceiling.

L586	L563	L521	L528	L546	L550
Fire Resistance Ratings: ANSI/UL 263	Same as L586	Same as L586	Same as L586	Same as L586	Same as L586
Finish flooring Nom 1" by 4". T&G laid perpendicular to trusses or 15/32" thick wood structural panels min. grade "Underlayment" or "Single Floor." Long dimensions of panel (strength axis) or face grain of plywood to be perpendicular to trusses with joints staggered.	Same as L586	Same as L586	Same as L586	Same as L586	Same as L586
Subflooring 23/32" thick T&G wood structural panels. Installed perpendicular to trusses with end joints staggered 4". Plywood or non-veneer APA rated panels secured to trusses with end joint staggered 4". Plywood or non-veneer APA rated panels secured to trusses with construction adhesive and #6d ringed shank nails. Nails spaced 12" on center along each truss. Staples having equal or greater withdrawal and lateral resistance strength may be substituted for the 6d nails.	Same as L586	Same as L586	Same as L586	Same as L586	Same as L586
Trusses: Parallel cord trusses a max. of 24" OC fabricated from nominal 2 x 4 lumber, with lumber oriented vertically or horizontally. Min. truss depth is 18". Truss members secured together with min. 0.0356" thick galvanized steel plates.	Same as L586	Same as L586	Same as L586	Same as L586	Same as L586
Air ducts: Any UL Class 0 or Class 1 flexible air duct installed in accordance with the instructions provided by the damper manufacturer.	Same as L586	Same as L586	None	Same as L586	Same as L586
Resilient Channels: Nom. 1/2" deep x 2" wide at base and 1 1/4" wide at the face, formed from .020" thick galvanized steel spaced 16" OC.	Same as L586	1/2" deep x 2 3/8" x .020" thick galvanized steel spaced 16" OC.	.022" thick galvanized steel spaced 16" OC.	3/8" deep x 2 3/8" x 1 3/8" x .020" thick galvanized steel spaced 16" OC.	1/2" deep x 2 3/8" x 1 1/8" x .020" thick galvanized steel spaced 16" OC.
Gypsum Board: Nom. 5/8" deep x 48" wide installed with long dimension perpendicular to Resilient channel with 1" long type "S" screws spaced 12" OC.	Gypsum Board: Nom. 5/8" thick x 48" wide installed with long dim. perpendicular to resilient channel with 1" long type "S" screws spaced 12" OC.	Gypsum Board: Nom. 5/8" thick x 48" wide installed with long dim. perpendicular to resilient channel with 1" long type "S" screws spaced 12" OC.	Gypsum Board: Nom. 5/8" thick x 48" wide installed with long dim. perpendicular to resilient channel with 1" long type "S" screws spaced 12" OC.	Gypsum Board: Nom. 5/8" thick x 48" wide installed with long dim. perpendicular to resilient channel with 1 1/8" long type "S" screws spaced 12" OC.	Gypsum Board: Nom. 5/8" thick x 48" wide installed with long dim. perpendicular to resilient channel with 1" long type "S" screws spaced 12" OC.

Specifications are subject to change without notice or obligation

CEILING RADIATION DAMPERS



CCD8

Masonry Ceiling Applications

UL 555C Classified

APPLICATION

The Lau CCD8 UL rated series of ceiling fire dampers provide protection to ceiling openings in fire-rated floor/ceiling assemblies with fire resistance ratings of 3 hours or less. UL fire rated floor/ceiling assemblies and roof/ceiling assemblies require specially tested and classified ceiling dampers (also called "ceiling fire dampers" or "radiation dampers") to provide fire and heat protection where HVAC components penetrate the ceiling membrane. **Standard, 1½ and 3 hour primary fire dampers DO NOT provide the necessary protection.**

STANDARD CONSTRUCTION

FRAME

20 gauge x 3½" deep galvanized steel.

BLADE

22 gauge galvanized steel with non-asbestos insulation.

FUSIBLE LINK

165°F is standard. 212°F is available at no additional cost.

MINIMUM SIZE

6"w x 6"h

MAXIMUM SIZE (DAMPER SIZES)

18"w x 18"h

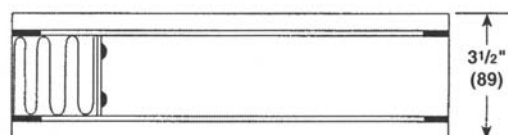
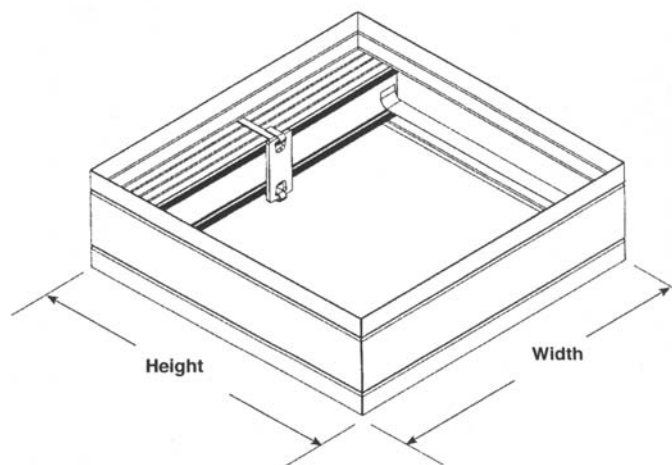

Specifications are subject to change without notice or obligation

CCDR5 Diffuser Radiation Shields, Lay-In UL555C Classified

APPLICATION

Most ceiling diffusers (particularly diffusers designed to “lay-in” exposed T-bar grid systems) cannot be used as they require an opening larger than permitted in any F/C or R/C design. Lau’s CCD(R)5 diffuser radiation shield solves this problem. It permits any manufacturer’s lay-in style steel ceiling diffuser (subject to gauge and dimension limitations) to be installed in UL Classified F/C or R/C assembly with Fire Resistance Ratings of 3 hours or less.

Underwriters Laboratories “Fire Resistance Directory” classified hundreds of specific Floor/Ceiling Designs (F/Cs) and Roof/Ceiling Designs (R/Cs) and establishes Fire Resistance Ratings for each design ranging from 1/2 hr. to 5 hrs. The majority of designs are rated at 2 hrs. or 3 hrs. Most F/Cs and R/Cs allow ceiling penetrations for HVAC on a limited and specific basis, typically one 12” dia. hole every 100 sq. ft. This hole must be protected in a very specific manner.

STANDARD CONSTRUCTION

FRAME

20 gauge galvanized steel. Frame depths are as shown in following chart.

DAMPER MODEL	FRAME STYLE	B DIMENSION or D DIAMETER	FRAME DEPTH
CCD5	Standard	All sizes	3"
	Extended	5" to 10"	6 ³ / ₈ "
		11" to 14" 15" to 24"	8 ³ / ₁₆ " 11 ³ / ₁₆ "
CCDR5	Standard	All sizes	3 ¹ / ₂ "
	Extended	5" to 10"	6 ⁷ / ₈ "
		11" to 14" 15" to 20"	6 ⁷ / ₈ " 11 ¹ / ₂ "

BLADE

20 gauge galvanized steel, with UL Classified insulation as required.

FUSIBLE LINK

165°F is standard. 212°F is available at no additional cost.

FINISH

Mill.

THERMAL INSULATION BLANKET

Mineral wool is standard. 1/2" Refractory Ceramic Fiber (RCF) is available at additional cost.

DIFFUSER PAN LIMITATION

24 gauge steel minimum.

DAMPER SIZES

MINIMUM SIZE (Inside Dimension)

Diffuser Neck – 4" w x 5" h or 5" in diameter

MAXIMUM SIZE (Inside Dimension)

Ceiling Opening – 24" x 24"

Diffuser Neck – 18" w x 18" h or 20" in diameter

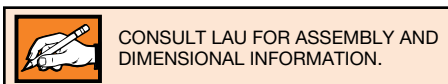
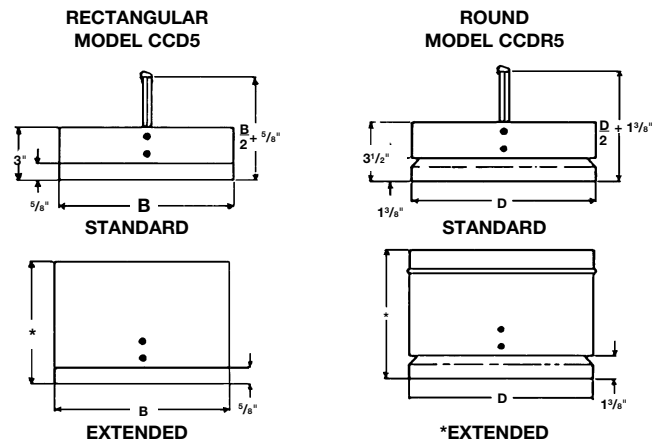
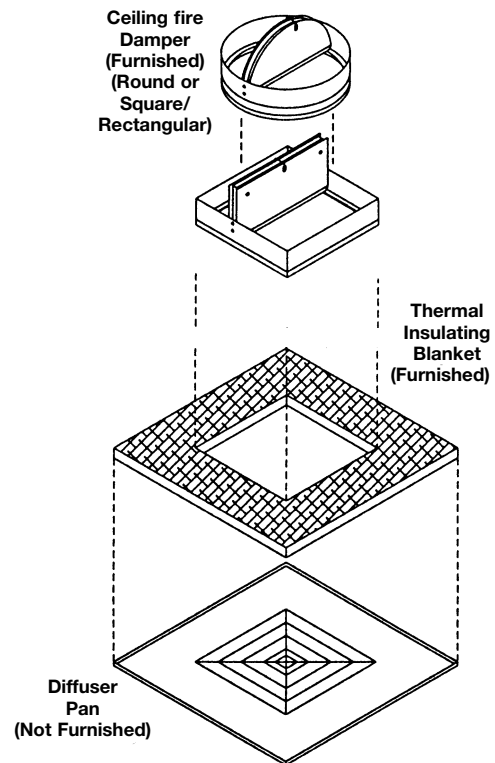

FIRE/SMOKE COMBINATION DAMPERS



General information

Controlled Closure

Electric Controlled Closure	Pneumatic Controlled Closure	Controlled Closure/Smoke Management
SMOKE DETECTION/TEST/POWER FAILURE OPERATION		
<p>When smoke is detected, during testing or if power failure occurs, the damper will close and remain closed. When the smoke signal ceases, the test is completed or power is restored the damper will automatically REMOTE RESET to the open position. The damper automatically resets if nuisance alarms occur and the system is reset. The damper may be closed at any time by placing the MCP1 (optional) or other control switch (by others) in the CLOSED position.</p>	<p>When smoke is detected, during testing or if power failure occurs, the damper will close and remain closed. When the smoke signal ceases, the test is completed or power is restored the damper will automatically REMOTE RESET to the open position. The damper automatically resets if nuisance alarms occur and the system is reset. EP, by others, must be present in system. The damper may be closed at any time by placing the MCP1 (optional) or other control switch (by others) in the CLOSED position.</p>	<p>When smoke is detected, during testing or if power failure occurs, the damper will close and remain closed. When the smoke signal ceases, the test is completed or power is restored the damper will automatically REMOTE RESET to the open position. The damper automatically resets if nuisance alarms occur and the system is reset. The damper may be closed at any time by placing the MCP1 (optional) or other control switch (by others) in the CLOSED position.</p>
FIRE OPERATION		
<p>When temperatures in excess of 165°F (212°F or 285°F optional) are detected, the damper will close and lock. At no time shall the damper be disengaged from the actuator. Upon cessation of the fire conditions, the damper can be reopened by pressing the reset button located on the damper assembly.</p>	<p>When temperatures in excess of 165°F (212°F or 285°F optional) are detected, the damper will close and lock. At no time shall the damper be disengaged from the actuator. Upon cessation of the fire conditions, the damper can be reopened by easily replacing the fuse link on the damper assembly.</p>	<p>When control switch is in the NORMAL position and temperatures in excess of 165°F (212°F or 285°F optional) are detected, the damper will close and lock. At no time shall the damper be disengaged from the actuator. The integral SP100 will communicate to the fire commander the position of the damper for smoke management purposes if interfaced with the fire command center. In this case, the damper CLOSED indicator will light. The damper remains closed until the override signal for smoke management from a remote command station is present and the duct temperature has not exceeded the high limit.</p> <p>The High Limit Temperature Sensor prevents the damper from reopening when duct temperature is above damper's UL555S degradation test temperature of 350°F or 450°F. Upon cessation of the fire conditions, the damper can be reopened by pressing the RESET button located on the damper assembly.</p>

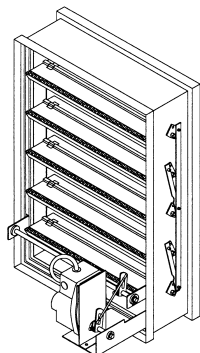

Internal Actuator Mounting

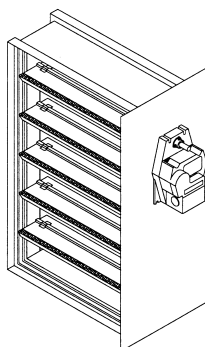

Sideplate Actuator Mounting

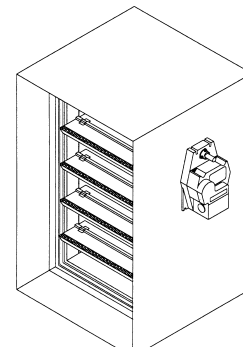

Sleeve Actuator Mounting

Specifications are subject to change without notice or obligation



FIRE/SMOKE COMBINATION DAMPERS

Use in Dynamic & Static Systems

CFS1

UL555S Leakage Class 1

1½ Hour UL 555 Rated

APPLICATION

The CFS1 is a combination fire/smoke damper that provides point-of-origin fire containment and operations flexibility in static and dynamic smoke management systems. The CFS1 may be installed vertically in walls or horizontally in floors in HVAC systems with velocities to 2,000 fpm and pressures to 4 inches w.g. (consult Lau for proper application if velocity and pressure exceed those listed above).

STANDARD CONSTRUCTION

FRAME

5" x 16 gauge galvanized, hat-shaped channel. Structurally superior to 13 gauge channel frame.

BLADES

6" wide galvanized steel. Triple V-groove (standard) or airfoil (factory option) shaped approximately 6" on center. Customer may specify airfoil for additional charge.

BEARINGS

Stainless steel sleeve, pressed into frame.

JAMB SEALS

Stainless steel, flexible metal compression type.

BLADE SEALS

Silicone edge type for smoke seal to 450°F and galvanized steel for flame seal to 1,900°F.

LINKAGE

Concealed in frame.

CONTROLLED CLOSURE DEVICE (Heat-Actuated)

165°F standard. 212°F, 250°F or 350°F are available at no additional cost (285°F PFL only).

DAMPER SIZES

MINIMUM SIZE

8"w x 6"h

MAXIMUM SIZE

Single Section

Vertical or Horizontal Installation – 32"w x 48"h

Multiple Section

Vertical Installation – 120"w x 96"h

Horizontal Installation – 144"w x 96"h

OPTIONS

- **TS150 FireStat** for re-openable operation in dynamic smoke management systems.
- **DSDF/DSDN Duct Smoke Detector** (flow rated or no flow).
- **SP100 Switch Package** to remotely indicate damper blade position.
- **FAST Angle** factory supplied for labor saving angle one-side installation.
- **PFMA** Picture Frame Mounting Angles factory matched and shipped with each damper.
- **Factory Sleeve** of various lengths and gauges to insure field compliance with UL installation requirements.
- **MCP** control panels for test purposes or smoke management systems.

Model CFS1 meets the requirements for fire dampers established by:

- **National Fire Protection Association** NFPA Standards 90A, 92A, 92B and 101
- **BOCA National Building Codes**
- **ICBO Uniform Building Codes**
- **SBCCI Standard Building Codes**
- **IBC International Building Codes**
- **CSFM California State Fire Marshal** (consult Lau for complete list of CSFM listed products)



SEE COMPLETE MARKING ON PRODUCT

FEATURES

- EFL (Electric Fuse Link) or PFL (Pneumatic Fuse Link) heat-actuated release devices permit controlled (rather than instantaneous) closure through the damper actuator. The EFL and PFL allow the damper to automatically reopen after a test, smoke detection or power failure condition.
- EFL is standard on dampers with electric actuators.
- PFL is standard on dampers with pneumatic actuators.
- EFL's may be ordered on dampers with pneumatic actuators but require an additional EP switch.

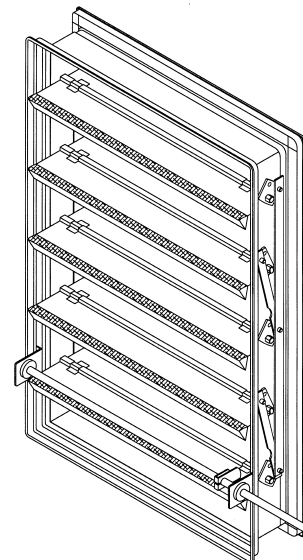

1. Dampers furnished approximately 1/4" smaller than given opening dimensions.

Specifications are subject to change without notice or obligation

FIRE/SMOKE COMBINATION DAMPERS

Use in Dynamic & Static Systems



CFS1

UL555S Leakage Class 1

1 1/2 Hour UL555 Rated

AIR PERFORMANCE DATA

To Determine the Air Performance:

Locate the applicable feet per minute face velocity on the bottom of the velocity vs. pressure drop chart below. Move up the chart to the most appropriate size damper line. From the intersection point, move left to determine the pressure drop on the left side of the chart.

For other damper sizes refer to **Air Performance Data For All Fire and Smoke Dampers** spec sheet.

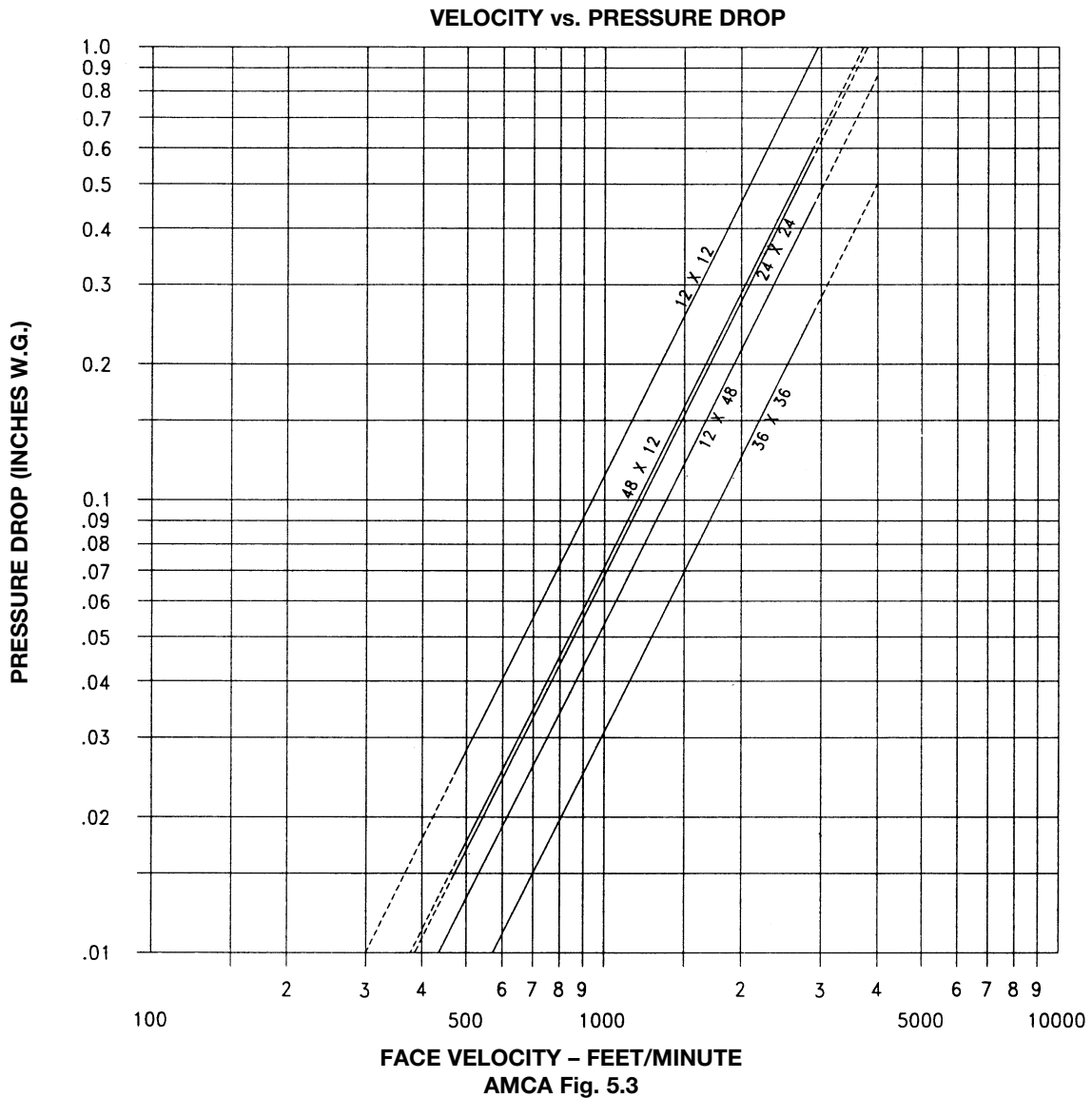

Specifications are subject to change without notice or obligation

CFS2

UL555S Leakage Class 2

1½ Hour UL 555 Rated

APPLICATION

The CFS2 is a combination fire/smoke damper built with triple V-groove blades and controlled closure technology that provides point-of-origin fire containment and operational flexibility in static and dynamic smoke management systems.

The CFS2 may be installed vertically in walls or horizontally in concrete floors in HVAC systems with velocities to 2,000 fpm and pressures to 4 inches w.g. (consult Lau for proper application if velocity and pressure exceed those listed above).

STANDARD CONSTRUCTION

FRAME

5" x 16 gauge galvanized hat-shaped steel channel.
Structurally superior to 13 gauge channel frame.

BLADES

6" wide, 16 gauge galvanized steel, triple V-group shaped approximately 6" on center.

BEARINGS

Stainless steel sleeve pressed into frame.

JAMB SEALS

Stainless steel, flexible metal compression type.

BLADE SEALS

Silicone edge type for smoke seal to 450°F and galvanized steel for flame seal to 1,900°F.

LINKAGE

Concealed in frame.

CONTROLLED CLOSURE DEVICE (Heat-Actuated)

EFL (Electric Fuse Link)
165°F standard. 212°F, 250°F or 350°F are options.
PFL (Pneumatic Fuse Link)
165°F standard. 212°F or 285°F are options.

DAMPER SIZES

MINIMUM SIZE

8"w x 6"h

MAXIMUM DAMPER SIZE

Vertical Installation – 126"w x 96"h or 72"w x 122"h
Horizontal Installation – 144"w x 96"h

FEATURES

- EFL (Electric Fuse Link) or PFL (Pneumatic Fuse Link) heat-actuated release devices permit controlled (rather than instantaneous) closure through the damper actuator. The EFL and PFL allow the damper to automatically reopen after a test, smoke detection or power failure condition.
- EFL is standard on dampers with electric actuators.
- PFL is standard on dampers with pneumatic actuators.
- EFL's may be ordered on dampers with pneumatic actuators but require an additional EP switch.

Model CFS2 meets the requirements for fire dampers established by:

- National Fire Protection Association** NFPA Standards 90A, 92A, 92B and 101
- BOCA National Building Codes**
- ICBO Uniform Building Codes**
- SBCCI Standard Building Codes**
- IBC International Building Codes**
- CSFM California State Fire Marshal** (consult Lau for complete list of CSFM listed products)

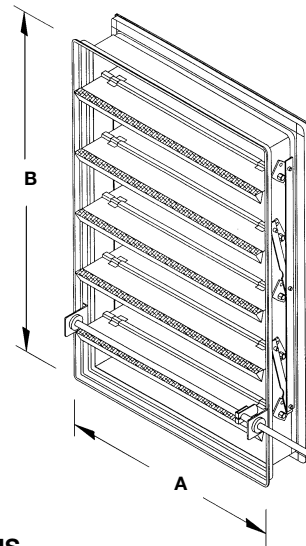

OPTIONS

- TS150 FireStat** for re-openable operation in dynamic smoke management systems.
- DSDP/DSDN Duct Smoke Detector** (Flow rated or No-flow).
- FAST Angle** factory supplied for labor saving angle one-side installation.
- PFMA** Picture Frame Mounting Angle factory supplied for angle two-sides installation.
- G Style** for grille applications.
- GA, Grille Access Type** for "through-the-grille access" to actuator and control devices (contact Lau).
- OW, Out of Wall/Floor Type** for "through penetrations" (contact Lau).
- RA, Integral Retaining Angle Type** for "fool proof" one side installation (contact Lau).
- Factory Sleeves** of various lengths and gauges to insure compliance with UL installation requirements.
- Access Doors** factory mounted in common sleeve to insure compliance with UL installation requirements.
- MCP** master control panels for test purposes or smoke management systems.
- FM Approval.**



1. Dampers furnished approximately 1/4" smaller than given opening dimensions.

Specifications are subject to change without notice or obligation

FIRE/SMOKE COMBINATION DAMPERS

Use in Dynamic & Static Systems



CFS2

UL555S Leakage Class 2

1½ Hour UL555 Rated

AIR PERFORMANCE DATA

To Determine the Air Performance:

Locate the applicable feet per minute face velocity on the bottom of the velocity vs. pressure drop chart below. Move up the chart to the most appropriate size damper line. From the intersection point, move left to determine the pressure drop on the left side of the chart.

For other damper sizes refer to **Air Performance Data For All Fire and Smoke Dampers** spec sheets.

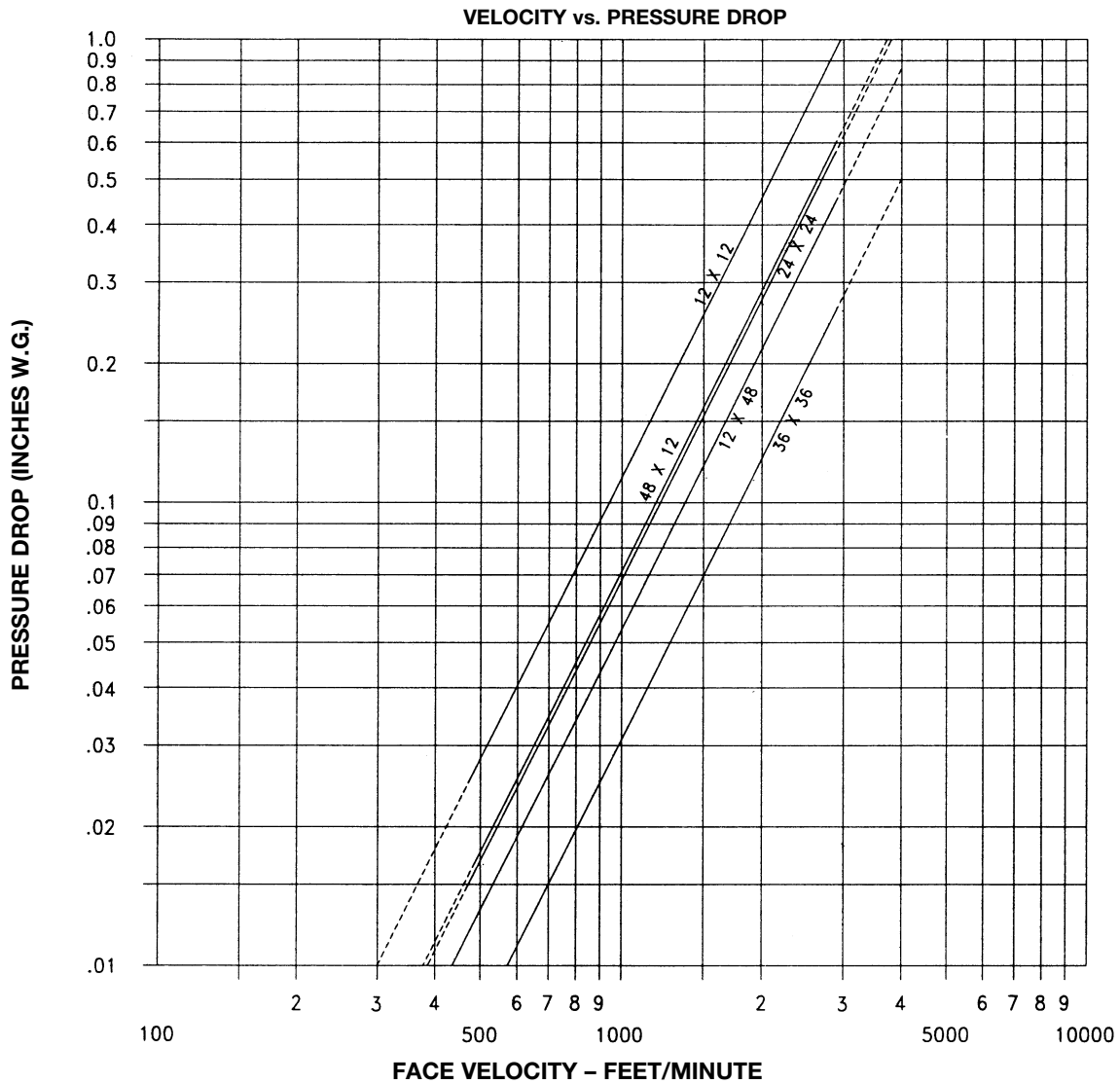

Specifications are subject to change without notice or obligation

CFS1, CFS2 Space Envelopes & Dimensional Data

SPACE ENVELOPE

Externally mounted actuators require space outside the damper sleeve. The “S” dimension is the “side” clearance, the “T” dimension is the “top” clearance and the “B” dimension is the “bottom” clearance required for the various actuators approved for use with Lau fire/smoke dampers. Actuators and accessories are factory mounted on the right side when viewed from the actuator side of the wall or floor. Lau fire/smoke dampers can be rotated or turned over to accommodate the application. If the actuator must be mounted on top or bottom, contact Lau.

The most commonly used electric actuators are shown in the table below. Refer to the **Actuators And Accessories Space Envelopes For All Fire and Smoke Dampers** data sheet for actuators and space information not shown.

ACTUATORS	H (Damper Height)	S	T	B
ML4202, H2000, H2024	15"	4"	0"	N/A
MS4209, MS8209	15"	4"	0"	N/A
MS4120, MS8120	17"	5"	0"	N/A
FSNF120, GGD221	17"	5"	0"	N/A



- The “H” dimension represents the required height to encompass the actuator and accessories with nothing protruding above or below the damper.
- The “B” (bottom) dimension does **Not Apply** to the “H” sizes shown. The MS4120, MS8120, FSNF120 and GGD221 will hang below the damper on sizes 10" high and shorter.

DAMPER SLEEVE DIMENSIONAL DATA

The drawing and corresponding table show the position of the damper when mounted in a factory sleeve. The standard mounting locations provide enough space for the mounting of actuators, controls and allow space for installation of retaining angles and duct connections. The minimum factory sleeve length is 17". Consult Lau for shorter sleeve lengths.

The standard location of a damper mounted in a factory sleeve (“L” dimension) is shown at right.



The entire damper frame is not required to be installed within the wall. The damper blades, when closed should be contained within the wall.

*Minimum Sleeve Length Formula:

$$\text{Sleeve Length} = \text{“L” dimension} + \text{wall/floor thickness} + 3" \text{ sleeve non-motor side}$$

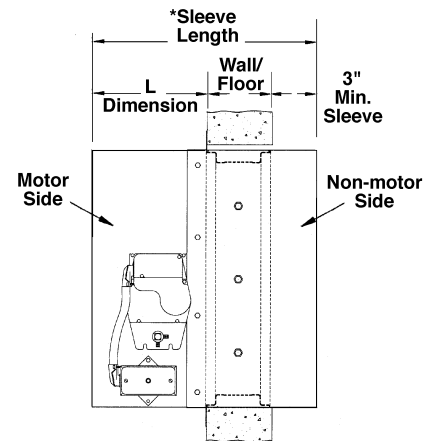
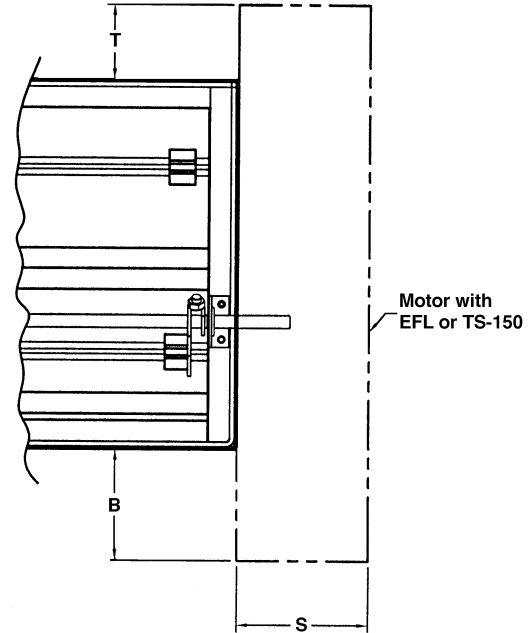

See basic UL Installation Instructions for complete installation requirements.

	All dampers with EFL or PFL		All dampers with TS150 or SP100							
	Over 10" High	10" High and Under	Electric Actuators		Pneumatic Actuators					
			Over 21" High (see note)	21" High and Under (see note)	331-4827(P)		331-2961(P)		331-3060(P)	
			Over 28" High	28" High & Under	Over 32" High	32" High & Under	Over 40" High	40" High & Under		
“L”	7 ¹ / ₈ "	10 ⁵ / ₈ "	7 ¹ / ₈ "	10 ⁵ / ₈ "	7 ¹ / ₈ "	10 ⁵ / ₈ "	7 ¹ / ₈ "	10 ⁵ / ₈ "	7 ¹ / ₈ "	10 ⁵ / ₈ "

Specifications are subject to change without notice or obligation

FIRE/SMOKE COMBINATION DAMPERS

Use in Dynamic & Static Systems



CFSR25

UL555C Leakage Class 1

1½ Hour UL555 Rated

APPLICATION

The CFSR25 is a "true" round Class 1 leakage rated fire/smoke damper. The CFSR25 can be installed vertically or horizontally. It is the ideal choice depending on application, when round duct is used on a project. The damper is rated for maximum velocity of 3,000 fpm and 4 inch static pressure. The integral frame and unique "cinch plate" design provides a low cost, easy to install, high performing damper.

STANDARD CONSTRUCTION

FRAME/SLEEVE

20 gauge galvanized steel, standard 17" long. Frame/sleeves available up to 36" in length. See minimum sleeve length chart on **Page 155** for assistance in choosing correct frame/sleeve length.

BLADES

Two-piece 14 gauge equivalent thickness galvanized steel.

BEARINGS

Stainless steel sleeve, pressed into frame.

BLADE SEALS

Silicone edge type sandwiched between two piece blade. Full circumference smoke seal to 450°F.

LINKAGE

Jackshaft to blade.

AXLE

1/2" diameter

CONTROLLED CLOSURE DEVICE (Heat-Actuated)

165°F standard. 212°F, 250°F, 285°F or 350°F are available at no additional cost.

DAMPER SIZES

MINIMUM SIZE

6" diameter

MAXIMUM SIZE

Vertical / Horizontal Installation – 24" diameter
See **Page 155** for dimensional information.

OPTIONS

- **TS150 FireStat** for re-openable operation in dynamic smoke management systems.
- **DSDF Flow Duct Smoke Detector** – Consult Lau.
- **SP100 Switch Package** to remotely indicate damper blade position.
- **Sleeve/Frame** of various lengths to insure field compliance with UL installation requirements.
- **MCP** control panels for test purposes or smoke management systems.
- **FM Approval.**

Model CFSR25 meets the requirements for fire dampers established by:

- **National Fire Protection Association NFPA Standards** 90A, 92A, 92B and 101
- **BOCA National Building Codes**
- **ICBO Uniform Building Codes**
- **SBCCI Standard Building Codes**
- **IBC International Building Codes**
- **CSFM California State Fire Marshal** (consult Lau for complete list of CSFM listed products)



FEATURES

- EFL (Electric Fuse Link) or PFL (Pneumatic Fuse Link) heat-actuated release devices permit controlled (rather than instantaneous) closure through the damper actuator. The EFL and PFL allow the damper to automatically reopen after a test, smoke detection or power failure condition.
- EFL is standard on dampers with electric actuators.
- PFL is standard on dampers with pneumatic actuators.
- EFL's may be ordered on dampers with pneumatic actuators but require an additional EP switch (consult factory).

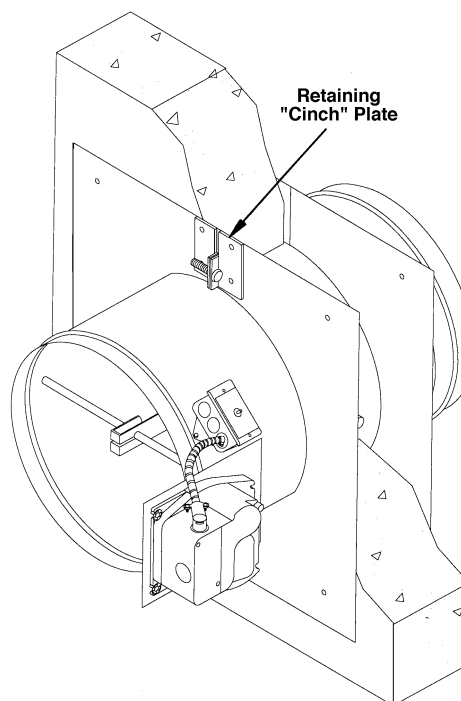

1. Units furnished approximately 1/8" smaller than given size.

Specifications are subject to change without notice or obligation

CFSR25

UL555C Leakage Class 1

1 1/2 Hour UL 555 Rated

The "L" dimension is the dimension the sleeve, on the actuator side of the damper, can extend beyond the wall or floor in a standard installation. The "L" dimension is designed to provide the installer with information to make installation easier. The table below provides a range for the "L" dimension.

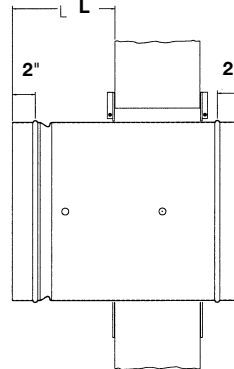

"L" DIMENSIONS

MINIMUM SLEEVE LENGTH

Wall/Floor Thickness	Min. Sleeve Length
4"	17"
5"	17"
6"	20"
7"	20"
8"	20"
9"	22"
10"	22"
11"	23"
12"	24"
Over 12" Thru 24"	Add 1" for every inch of wall/floor depth

WALL THICKNESS							
	4"	5"	6"	7"	8"	9"	10"
Minimum	8 1/4"	8 1/4"	8 1/4"	8 1/4"	8 1/4"	8 1/4"	8 1/4"
Standard	9"	9"	9"	9"	9"	9"	9"
Maximum	10"	10"	10"	10"	10"	10"	10"

NOTE: The 2" dimension is for duct connections. The "L" dimension includes the 2" for duct connection.

NOTE: 36" maximum sleeve length.

GENERAL INSTALLATION INFORMATION

METAL/WOOD/MASONRY WALL OR CONCRETE FLOOR INSTALLATION

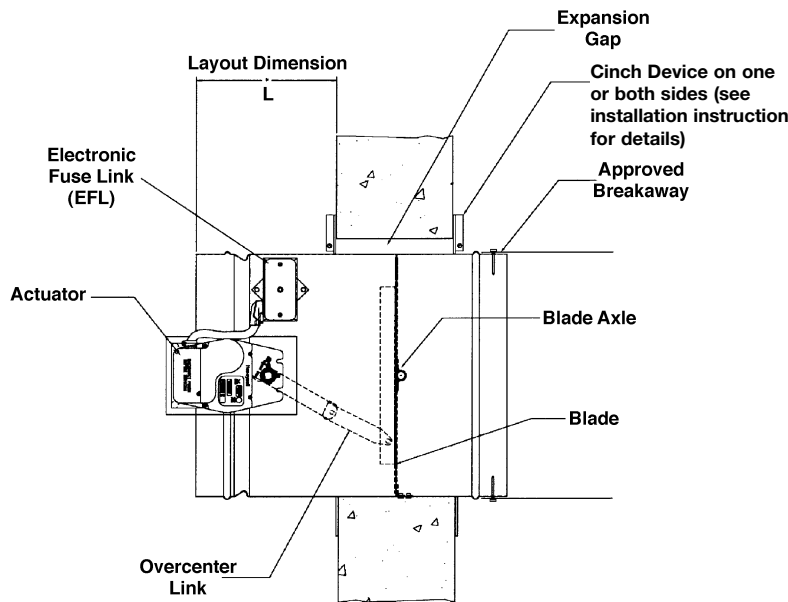

RETAINING "CINCH" PLATE

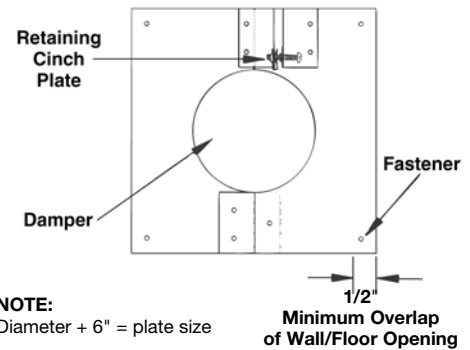

A square opening in wood or metal stud walls or masonry walls and floors shall be a minimum of 1" and a maximum of 2 1/2" larger than the damper diameter. See wood stud and metal stud framing for fire dampers installation instructions supplement for complete framing details. A round opening in masonry walls or floors shall be a minimum of 1" and a maximum of 2 1/2" larger than the damper diameter.

Factory supplied retaining "cinch" plates hold the damper within the wall opening. The plates must overlap the opening a minimum of 1/2". The plate fits snugly around the integral sleeve. The plates are fastened directly to the wall or floor.

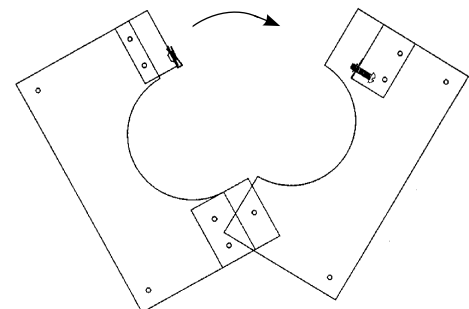

Refer to the CFSR25 Installation Instructions for complete installation details.

Specifications are subject to change without notice or obligation

FIRE/SMOKE COMBINATION DAMPERS

Use in Dynamic & Static Systems



CFS2C – CORRIDOR DAMPER

UL555S Leakage Class 2

1 Hour UL555 Rated

APPLICATION

The CFS2C is a one-hour fire/smoke rated corridor damper. Corridor dampers are tested in accordance to UL555 and is Class 2 leakage rated per UL555S. The CFS2C is available in different configurations for installation and access requirements. The illustrations on **Page 156** depict the different configurations.

The CFS2C damper is for use where air ducts penetrate or terminate at horizontal openings in the ceilings of wood stud or metal stud constructed interior tunnel corridors. The damper fails closed upon loss of power and mounts horizontally. It is designed for use in systems with airflow in either direction with velocities to 2,000 fpm and pressures to 4 inches w.g.

STANDARD CONSTRUCTION

FRAME

5" x 20 gauge galvanized, hat-shaped steel channel.

SLEEVE

18 1/2" x 20 gauge galvanized steel.

BLADES

Triple V-groove type, 16 gauge galvanized steel, maximum 6" wide.

BEARINGS

Stainless steel sleeve, pressed into frame.

BLADE SEALS

Silicone edge type for smoke seal to 450°F and galvanized steel for frame seal to 1,900°F.

LINKAGE

Concealed in frame.

AXLE

1/2" plated steel hex.

CONTROLLED CLOSURE DEVICE (Heat-Actuated)

165°F standard. 212°F, 250°F, 285°F or 350°F are available at no additional cost.

UL555S ELEVATED TEMPERATURE RATING

250°F or 350°F depending on actuator.

DAMPER SIZES

MINIMUM SIZE

8" w x 6" h

NOTE: See **Page 156** for actuator in air stream minimums.

MAXIMUM SIZE

Single Section – 24" w x 24" h

OPTIONS

- **TS150 FireStat** for re-openable operation in dynamic smoke management systems.
- **DSDP/DSDN Duct Smoke Detector** – Flow rated or no-flow.
- **SP100 Switch Package** to remotely indicate damper blade position.
- **Sleeve** in lengths other than 18 1/2" and gauges to insure field compliance with UL installation requirements.
- **MCP** control panels for test purposes or smoke management systems.
- **FM Approval.**

Model CFS2C meets the requirements for fire, smoke and combination dampers established by:

- **National Fire Protection Association NFPA Standards** 90A, 92A, 92B and 101
- **BOCA National Building Codes**
- **ICBO Uniform Building Codes**
- **SBCCI Standard Building Codes**
- **IBC International Building Codes**
- **CSFM California State Fire Marshal** (consult Lau for complete list of CSFM listed products)



FEATURES

- EFL (Electric Fuse Link) or PFL (Pneumatic Fuse Link) heat-actuated release devices permit controlled (rather than instantaneous) closure through the damper actuator. The EFL and PFL allow the damper to automatically reopen after a test, smoke detection or power failure condition.
- EFL is standard on dampers with electric actuators.
- PFL is standard on dampers with pneumatic actuators.
- EFL's may be ordered on dampers with pneumatic actuators but require an additional EP switch (consult factory).

CFS2C1
DUCTED CORRIDOR DAMPER

CFS2C1, C2, C3
DIFFUSER CORRIDOR DAMPER

CFS2C4
CORRIDOR DAMPER FOR STOCK

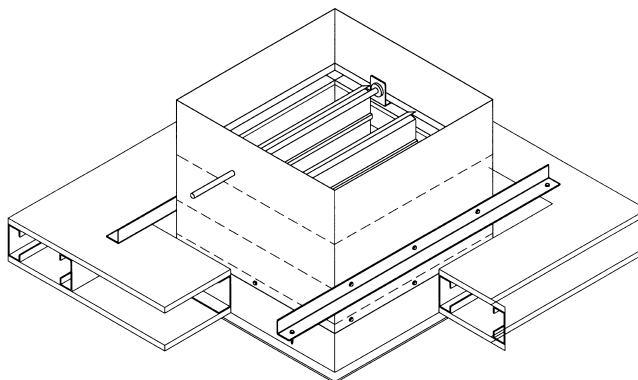

1. A and B dimensions are **actual** dimensions to the inside of the sleeve.

Specifications are subject to change without notice or obligation

CFS2C – CORRIDOR DAMPER

UL555S Leakage Class 2

1 Hour UL555 Rated

CFS2C1 WOOD OR METAL STUD DUCTED THROUGH PENETRATION

This illustration depicts the **C1** application which is applied in a ducted fire rated ceiling above the finished ceiling. Actuators can be mounted internally or externally above or below the rated ceiling. See *actuator limitations on Page 156*.

*If space is a problem the 9 1/2" dimension can be reduced to 6 3/4" by relocating the EFL, PFL, TS150 or SP100 (consult Lau).

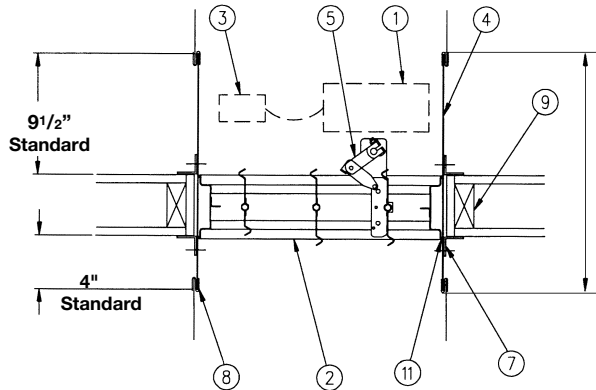

ITEM DESCRIPTION

1. Actuator (location may vary)
2. Damper Frame
3. TS150 FireStat, EFL or PFL (location may vary)
4. Sleeve (20 gauge standard)
5. Over Center Link
6. Mounting Angles 1 x 2 1/2 x 16 gauge
7. Mounting angles 1 1/2 x 1 1/2 x 20 gauge
8. Sleeve to Duct Break-away Connections
9. Single Stud Construction
10. Steel grille/diffuser (by others)
11. Caulking Material (meets 25/50 flame spread/smoke developed criteria)

CFS2C2 WOOD OR METAL STUD WITH V-FRAME DIFFUSER

This illustration depicts the **C2** application which is applied with a V-Frame diffuser and the fire rated ceiling is the finished ceiling. Access to the actuator is available from the finished ceiling (**external mount**) or through the diffuser (**internal mount**). See *actuator limitations on Page 160*. Lau will configure the assembly based on internal or external mount actuator.

*If space is a problem the 14 1/2" dimension and sleeve length can be shortened (consult Lau).

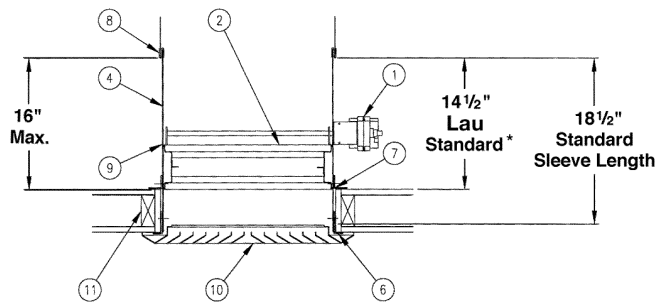

EXTERNAL MOUNT ACTUATOR

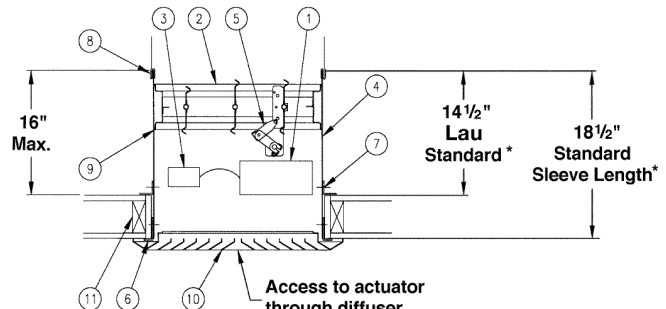

INTERNAL MOUNT ACTUATOR

CFS2C3 METAL STUD WITH FLAT FRAME DIFFUSER

This illustration depicts the **C3** application which is applied with a Flat-Frame diffuser and the fire rated ceiling (**metal stud only**) is the finished ceiling. Access to the actuator is available from above the finished ceiling (**external mount**) or through the diffuser (**internal mount**). See *actuator limitations on Page 156*. Lau will configure the assembly based on internal or external mount actuator.

*If space is a problem the 14 1/2" dimension and sleeve length can be shortened (consult Lau).

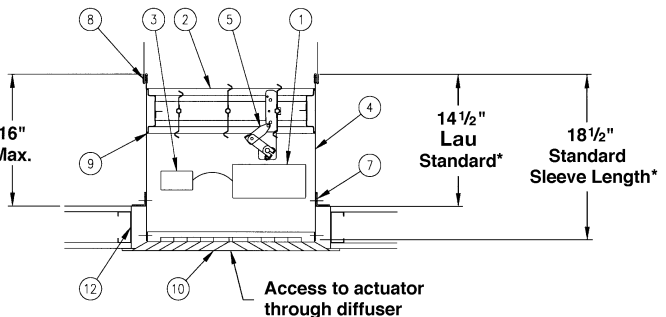
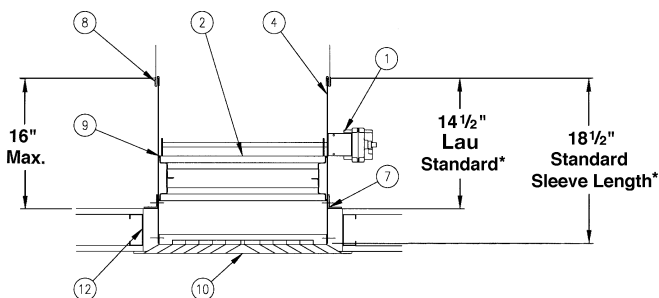

FIRE/SMOKE COMBINATION DAMPERS

Use in Dynamic & Static Systems



CFS2C – CORRIDOR DAMPER

UL555S Leakage Class 2

1 Hour UL555 Rated

CFS2C4 CORRIDOR OR COMBINATION FIRE AND SMOKE DAMPER

The CFS2C4 is both a 1 hour rated corridor damper and a standard 1½ hour fire and smoke damper for walls and floors. The C4 is ordered for stock and provided when either a corridor or standard fire/smoke damper is required by the customer. The C4 is configured the same as the C1 with external mounted actuators only and shipped complete with PFMA retaining angles and a 1" x 2½" x 16 gauge mounting angle (angles shipped loose).

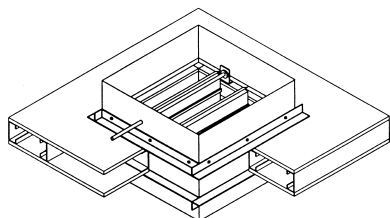

C4 INSTALLED IN TUNNEL CORRIDORS

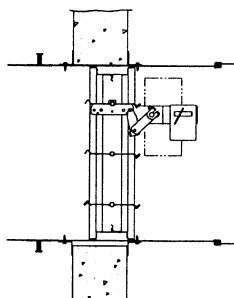

C4 INSTALLED IN WALLS

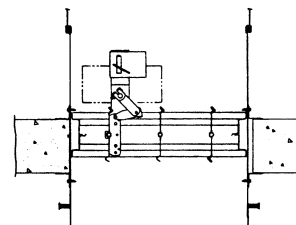

C4 INSTALLED IN FLOORS

REQUIRED MOUNTING ANGLES

C1 installations

PFMA or Retaining angles (shipped loose)
(Supplied by factory/additional charge)

C2 installations

4 each special 1" x 2½" x 16 gauge angle (provided by factory as standard and shipped loose)
1 each FAST (shipped loose or factory mounted/additional charge)

C3 installations

2 each 1" x 1½" x 30" minimum 16 gauge retaining angle
(Supplied by factory/additional charge)

C4 installations

All angles for C1, C2 or standard wall installations are factory provided for field determination of application.

OPTIONAL ROUND TOP OR SIDE CONNECTIONS

The CFS2C is available with round transitions for attachment to round duct. Use the **R style** when the application is an CFS2C1 application. Use the **RT style** when the application is an CFS2C2 or C3 application. The CFS2C is also available with a round side connection. Consult Lau prior to using the round side connection. R style and RT style dampers are available in sizes 4" to 22". The rectangular damper size is standard 2" larger than the R or RT style size. For example 6" RT style damper is standard 8" x 8". Consult Lau for non-standard sizes.

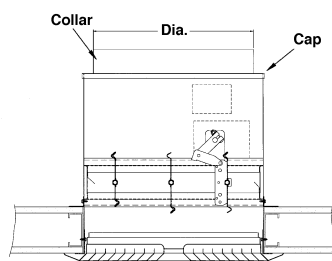

ROUND TOP CONNECTION RT STYLE

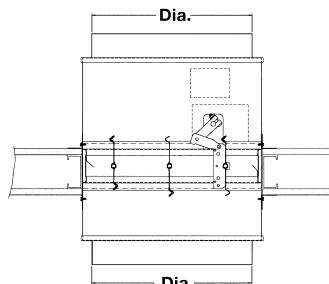

R STYLE

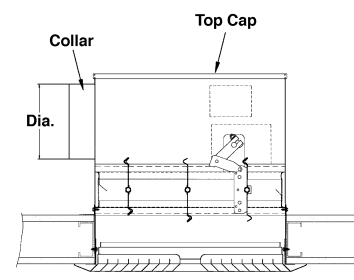

ROUND SIDE CONNECTION

FACTORY INSTALLED DAMPER ACTUATORS

Damper size maximums for each actuator, shown in the chart below, are based on fail closed operation, in which the damper closes when power is interrupted to the actuator. This is a Normally Closed (NC) actuator connection, Normally Open (NO) is not available.

Actuator damper size limitations are based on initial testing conducted for the corridor dampers. Consult Lau for additional UL listed actuators and for their size and temperature limitations.

FAIL CLOSE ACTUATORS

Model	Electric Description	Voltage	UL 555S Elevated Temp.	Max. Size for FCFS2/60-C	Min. Size for Actuator in Air Stream	
					W/EFL	W/EFL/SP100 or TS150
H2000/3	Two position	120 AC	250°F	24" x 24"	10" x 10"	16" x 14"
H2000/4	Two position	120 AC	350°F	24" x 24"	10" x 10"	16" x 14"
H2024/3	Two position	24 VAC	250°F	24" x 24"	10" x 10"	16" x 14"
H2024/4	Two position	24 VAC	350°F	24" x 24"	10" x 10"	16" x 14"

Specifications are subject to change without notice or obligation

CSD37
UL555S Classified
Leakage Class 1

APPLICATION

The CSD37 is a one-piece airfoil or triple V-groove bladed UL555S Leakage Class 1 Classified smoke damper for use in ducts that penetrate smoke rated barriers. The CSD37 may be installed vertically within 24" of walls and horizontally within 24" above or below floors. The CSD37 is for use in systems with airflow in either direction, with velocities 2,000 fpm and pressures to 4 inches w.g.

STANDARD CONSTRUCTION

FRAME

5" x 16 gauge galvanized single piece hat-shaped steel channel, structurally superior to 13 gauge channel frame.

BLADES

6" wide, 16 gauge equivalent thickness galvanized steel, approximately 6" on center, triple V-groove or one-piece airfoil shaped (factory option).

LINKAGE

Concealed in frame.

BEARINGS

Stainless steel sleeve, pressed into frame.

JAMB SEALS

Stainless steel, flexible metal compression type.

BLADE SEALS

Silicone edge type mechanically fastened to the blade edge, for smoke seal to 450°F.

UL555S ELEVATED TEMPERATURE RATING

250°F or 350°F depending on actuator.

DAMPER SIZES

MOUNTING

Vertical or horizontal.

MINIMUM SIZE

8"w x 6"h

Dampers less than 12" wide are Leakage Class 2.

MAXIMUM SIZE

Single Section – 36"w x 72"h

Multiple Section – 144"w x 96"h, 288"w x 48"h or 72"w x 144"h

OPTIONS

- **DSDN** Duct Smoke Detectors – for no or low air flow applications.
- **DSDL** Smoke Detectors – for low or normal air flow applications.
- **SP100 Switch Package** to remotely indicate damper blade position.
- **Sleeves** of various lengths and gauges.
- **"True Round"** smoke damper consult CSDRS25.
- **FM Approval.**

Model CSD37 meets the requirements for smoke dampers established by:

- **National Fire Protection Association** NFPA Standards 90A, 92A, 92B and 101
- **BOCA National Building Codes**
- **ICBO Uniform Building Codes**
- **SBCCI Standard Building Codes**
- **IBC International Building Codes**
- **CSFM California State Fire Marshal** (consult Lau for complete list of CSFM listed products)

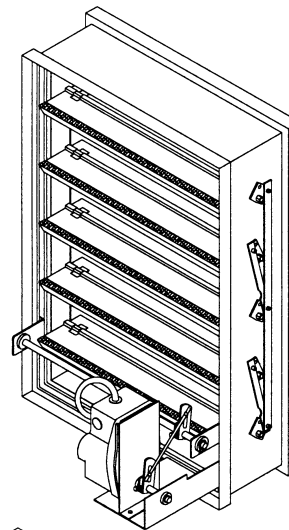

Internal Actuator Mounting

Actuators must be factory mounted

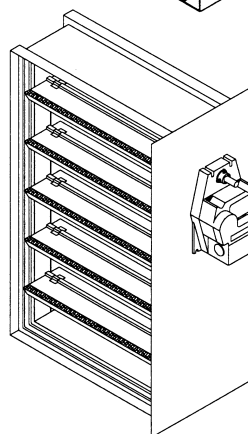

Sideplate Actuator Mounting

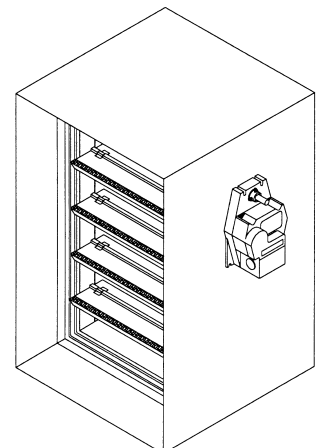

Sleeve Actuator Mounting



1. Dampers furnished approximately 1/4" less than given opening dimensions.

Specifications are subject to change without notice or obligation

SMOKE DAMPERS



CSD36

*UL555S Classified
Leakage Class 2*

APPLICATION

The CSD36 is a one-piece triple V-groove bladed UL555S Leakage Class 2 Classified smoke damper for use in ducts that penetrate smoke rated barriers. The CSD36 may be installed vertically within 24" of walls and horizontally within 24" above or below floors. The CSD36 is for use in systems with pressure up to 4 inches w.g. and 2,000 fpm air velocity.

STANDARD CONSTRUCTION

FRAME

5" x 16 gauge galvanized, single piece, hat-shaped channel, structurally superior to 13 gauge channel frame.

BLADES

6" wide, 16 gauge galvanized steel, approximately 6" on center. Triple V-groove shaped.

LINKAGE

Concealed in frame.

BEARINGS

Stainless steel sleeve, pressed into frame.

JAMB SEALS

Stainless steel, flexible metal compression type.

BLADE SEALS

Silicone edge type mechanically fastened to the blade edge for smoke seal to 450°F.

UL555S ELEVATED TEMPERATURE RATING

250°F or 350°F depending on actuator.

DAMPER SIZES

MINIMUM SIZE

8"w x 6"h

MAXIMUM SIZE

Single Section – 36"w x 72"h

Multiple Section – 144"w x 96"h, 72"w x 144"h or
288"w x 48"h

OPTIONS

- **DSDN** Duct Smoke Detectors – for no or low air flow applications.
- **DSDL** Smoke Detectors – for low or normal air flow applications.
- **SP100 Switch Package** to remotely indicate damper blade position.
- **Sleeves** of various lengths and gauges.
- **"True Round"** smoke damper consult CSDRS25.
- **FM Approval.**

Model CSD36 meets the requirements for smoke dampers established by:

- **National Fire Protection Association** NFPA Standards 90A, 92A, 92B and 101
- **BOCA National Building Codes**
- **ICBO Uniform Building Codes**
- **SBCCI Standard Building Codes**
- **IBC International Building Codes**
- **CSFM California State Fire Marshal** (consult Lau for complete list of CSFM listed products)

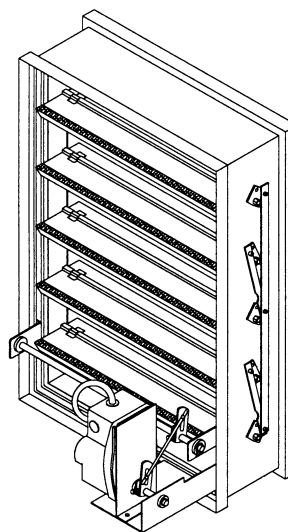

Internal Actuator Mounting

Actuators must be factory mounted

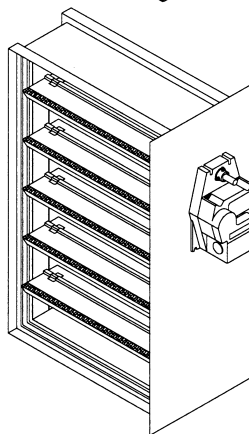

Sideplate Actuator Mounting

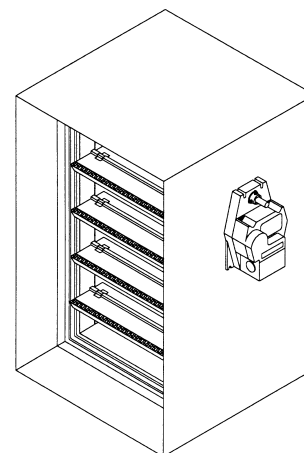

Sleeve Actuator Mounting



1. Dampers furnished approximately 1/4" less than given opening dimensions.

Specifications are subject to change without notice or obligation

CSDR25
UL555S Classified
Leakage Class 1

APPLICATION

The CSDRS25 is a “true round” single bladed UL555S Leakage Class 1 Classified smoke damper for use in ducts that penetrate smoke rated barriers. The damper is ideal for applications that require low pressure drop. The CSDRS25 may be installed vertically within 24" of walls and horizontally within 24" above or below floors. The CSDRS25 is designed for use in systems with airflow in either direction with velocities to 3,000 fpm and pressure to 4 inches w.g.

STANDARD CONSTRUCTION

FRAME

7" long, 20 gauge galvanized steel. 1½" x 1½" reinforcement ring for units above 20" diameter.

BLADE

Two-piece galvanized steel, 14 gauge equivalent thickness.

BEARINGS

Stainless steel sleeve, pressed into frame.

SEALS

Silicone rubber sandwiched between two blade pieces and fully encompasses blade edge.

UL555S ELEVATED TEMPERATURE RATING

250°F or 350° depending on actuator.

DAMPER SIZES

MOUNTING

Vertical or horizontal.

MINIMUM DAMPER SIZE

5" diameter

MAXIMUM DAMPER SIZE

24" diameter

OPTIONS

- FM Approval.

Model CSDRS25 meets the requirements for smoke dampers established by:

- **National Fire Protection Association** NFPA Standards 90A, 92A, 92B and 101
- **BOCA National Building Codes**
- **ICBO Uniform Building Codes**
- **SBCCI Standard Building Codes**
- **IBC International Building Codes**
- **CSFM California State Fire Marshal** (consult Lau for complete list of CSFM listed products)

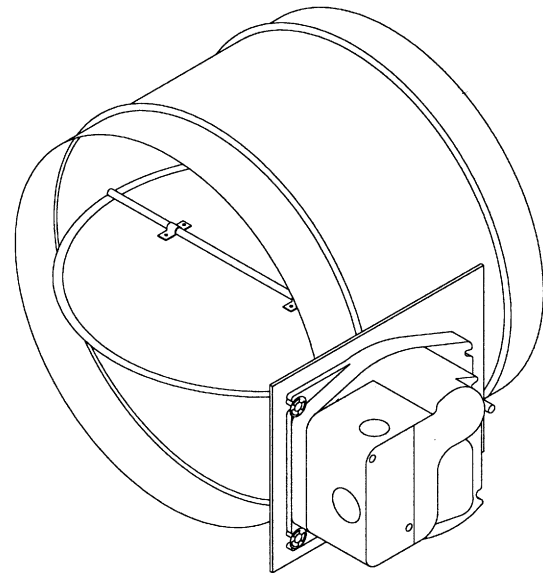

1. Dampers furnished approximately 1/8" less than D dimension.
2. All diameters between 5" and 24" available.

Specifications are subject to change without notice or obligation

Standard

APPLICATION

Lau access doors offer quick, easy and economical installation wherever duct access is needed. Manual locks assure tight door closure and the continuous piano-type hinge models give smooth operation. The CDRW and CDEW models feature a "see through" panel that permits visual duct inspection without door removal.

STANDARD CONSTRUCTION

FRAME

22 gauge galvanized steel with seal.

DOOR

24 gauge galvanized steel.

CDR14 – Removable, single skin.

CDE14 – Hinged, single skin.

CDR24 – Removable, double skin.

CDE24 – Hinged, double skin.

CDRW24 – Removable, double skin with round transparent plexiglass window.

CDEW24 – Hinged, double skin with round transparent plexiglass window.

HINGE (CDE Models Only)

Continuous piano type.

CAM LOCKS

CDE Models – Doors 16" and under have one lock, doors over 16" have two locks.

CDR Models – Doors 16" and under have two locks, doors over 16" have four locks.

MAXIMUM STATIC PRESSURE

Double skin access doors have been tested to 6 inches w.g. Leakage increases as system pressure increases.

SEALS

Foam gasket.

INSULATION

1" fiberglass.

ACCESS DOOR SIZES

MINIMUM SIZE

6"w x 6"h

MAXIMUM SIZE

24"w x 24"h

INSTALLATION

Cut hole $1\frac{1}{8}$ " smaller than door size.

OPTIONS

- Additional cam locks
- Wire reinforced glass window
- 20 gauge door panels
- Ventlock 100 latches
- Stainless steel construction
- Bronze hinge pins
- Brass cams
- Security chain
- Intermediate sizes between 6" x 6" and 24" x 24".

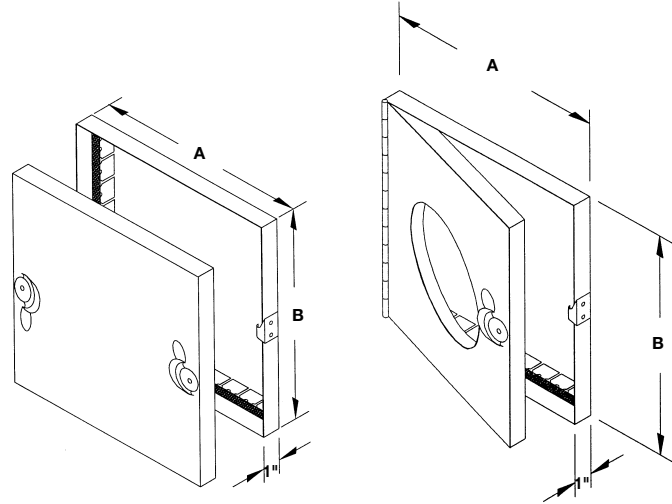

12" x 12" ACCESS DOOR

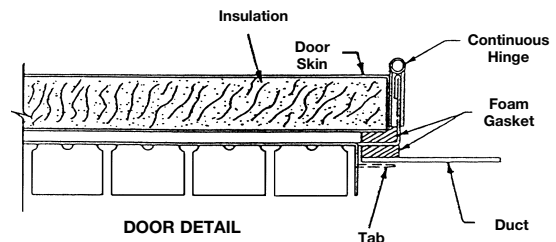
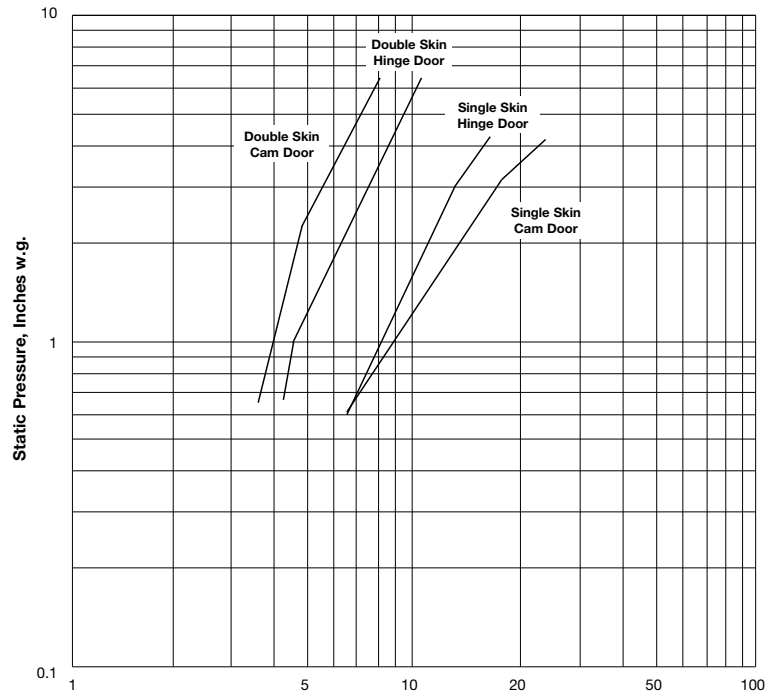

CDR & CDF QUICK FIT

For Round & Rectangular Ducts

APPLICATION

CDR and CDF access doors are an inexpensive, trouble-free way to gain access into sheet metal duct work systems for resetting dampers, cleaning filters, or access for general maintenance. The oval shaped opening permits the back plate or "inner plate" to be easily passed through the duct openings, and the neoprene gasket on the inner plate provides for an absolutely air-tight seal. The large hand knobs insure a quick method to remove and reinstall the door without the use of special tools.

The CDR (for round duct work) and CDF (for flat duct work) are available in three sizes, 16" x 12", 10" x 6" and 8" x 4" to accommodate the many different sizes of duct work that are available.

STANDARD CONSTRUCTION

METAL THICKNESSES

- 22 gauge steel - 10" x 6" door size.
- 20 gauge steel - 16" x 12" door size.

CELLULAR SPONGE GASKET

Fixed to the inner plate keeps the doors free of leaks at pressures to 20 inches w.g.

ACCESS DOOR MODELS AND SIZES

CDF

8" x 4", 10" x 6", 16" x 12"

CDR1 - 10" x 6"

Duct Sizes: 6", 8", 9", 10", 12", 14", 16", 18", 20", 22", 24", 26", 28", 30"

CDR2 - 16" x 12"

Duct Sizes: 18", 20", 22", 24", 26", 28", 30", 32", 34", 36", 38", 40", 42", 44", 46", 48", 50", 52", 54", 56", 58", 60"

CDR3 - 8" x 4"

Duct Sizes: 4", 6", 8", 9", 10", 12", 14", 16", 18", 20", 22", 24", 26", 28"

INSTALLATION INSTRUCTIONS

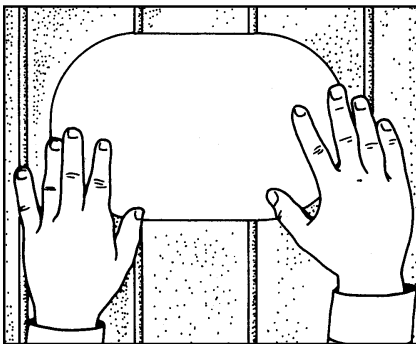

SELF-ADHESIVE TEMPLATES

are also provided so that the duct opening can be cut without expensive layout.

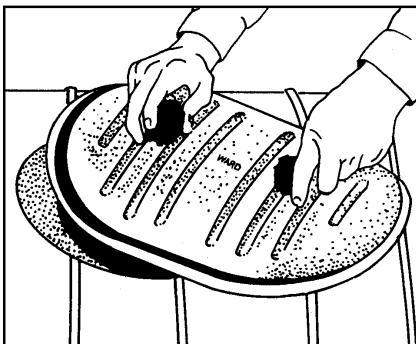

EASY INSTALLATION

after door opening has been cut, unscrew handles or door in insert in the opening, align then tighten knobs.



ACCESS DOOR CUTAWAY

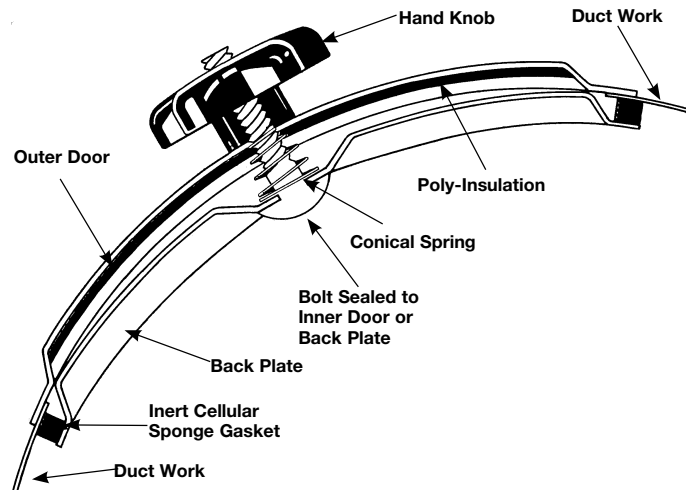

Milcor Fire Related Access Doors

APPLICATION

Milcor fire related access doors are designed for use in commercial construction.

FEATURES

Milcor doors feature high quality construction and are easy to install. Both NIFR and UFR styles are self closing, self latching, and have a cylinder lock with two keys (standard). Milcor doors meet the requirements of fire rated assemblies.

NIFR Style access doors have UL and CUL 1.5 hr, Class B fire rating and are available in custom-manufactured stainless steel.

UFR Style access doors have UL and CUL 1.5 hr, Class B fire rating and Warnock Hersey for 3-hour non-combustible floor/ceiling. They are available with a Mortise Cylinder option with the exception of the 8x8 size and stainless steel models.

NIFR Style

Non-Insulated Fire Rated Access Doors for Walls Only with Painted Steel Spider

Size	Wall Opening	No. of Locks	Shipping Weight (ea.)
8x8	8½ x 8½	1	7 lbs.
12x12	12½ x 12½	1	11 lbs.
14x14	14½ x 14½	1	13 lbs.
16x16	16½ x 16½	1	15 lbs.
18x18	18½ x 18½	1	18 lbs.
24x24	24½ x 24½	1	28 lbs.
22x30	22½ x 30½	1	29 lbs.
22x36	22½ x 36½	1	35 lbs.

UFR Style

Universal Fire Rated Access Doors for Walls and Ceilings Stainless Steel Construction

Size	Wall Opening	No. of Locks	Masonry Anchors	Shipping Weight (ea.)
12x12	12½ x 12½	1	4	10 lbs.
16x16	16½ x 16½	1	4	13 lbs.
18x18	18½ x 18½	1	4	17 lbs.
24x24	24½ x 24½	1	4	27 lbs.
24x36	24½ x 36½	1	4	44 lbs.

UFR Style

Universal Fire Rated Access Doors for Walls and Ceilings Painted Steel Construction

Size	Wall Opening	No. of Locks	Masonry Anchors	Weight Each (lbs.)	Exceptions
8x8	8½ x 8½	1	4	8 lbs.	Wall Only
12x12	12½ x 12½	1	4	12 lbs.	
12x24	12½ x 24½	1	4	19 lbs.	
14x14	14½ x 14½	1	4	15 lbs.	
16x16	16½ x 16½	1	4	17 lbs.	
18x18	18½ x 18½	1	4	21 lbs.	
22x30	22½ x 30½	1	4	35 lbs.	
22x36	22½ x 36½	1	4	40 lbs.	
24x24	24½ x 24½	1	4	32 lbs.	
24x30	24½ x 30½	1	4	38 lbs.	
24x36	24½ x 36½	1	4	42 lbs.	
24x48	24½ x 48½	2	6	50 lbs.	Wall Only
30x30	30½ x 30½	1	4	42 lbs.	Wall Only
32x32	32½ x 32½	1	4	45 lbs.	Wall Only
36x36	36½ x 36½	1	4	47 lbs.	Wall Only
36x48	36½ x 48½	2	6	70 lbs.	Wall Only
48x48	48½ x 48½	2	8	88 lbs.	Wall Only



For sizes not listed above, call Lau for pricing and lead times on custom-manufactured special sizes or options. Factory applies \$25 set-up fee.

STANDARD CONSTRUCTION

FRAME

5" x 1" x 16 gauge galvanized steel hat channel reinforced with corner braces for structural strength equal to 13 gauge channel frames. Low profile 3 1/2" x 3/8" x 16 gauge galvanized steel channel top and bottom frame on dampers under 13" high.

BLADES

6" wide, 16 gauge galvanized steel blades approximately 6" on center. Parallel or opposed action.

SEALS

Blade edge is PVC coated polyester fabric mechanically locked into blade edge. Jamb is flexible metal, compression type.

BEARINGS

Synthetic.

LINKAGE

Concealed in frame. Exposed linkage optional.

AXLES

1/2" plated steel hex.

CONTROL SHAFT

6" x 1/2" diameter. Outboard shaft support bearing supplied with all single section dampers for field mounted actuators. Factory-installed jackshaft supplied with all multiple section dampers.

FINISH

Mill.

MAXIMUM SIZE

Single section – 48" w x 72" h
Multiple section assembly – Unlimited size.

MINIMUM SIZE

Single blade – 5" w x 5" h
Two blades, parallel or opposed action, exposed linkage – 8" w x 14" h.
Two blades, parallel or opposed action, concealed linkage – 5" w x 10" h.

TEMPERATURE LIMITS

-25°F (-32°C) minimum and +180°F (+83°C) maximum.

Consult Lau if application involves pressures in excess of 2.5" w.g. or air velocities in excess of 2000 FPM.

VARIATIONS

Variations to the C302 basic design are available at additional cost. They include:

- Factory-installed, pneumatic and electric actuators (specific information required with order).
- SP100 Switch Package to remotely indicate damper blade position.
- Heavier frame construction with U-channel frame.
- Front, rear or double flange frame with or without bolt holes.
- 304 stainless steel construction.
- Shipping weight, approximately 7 lbs./sq. ft.

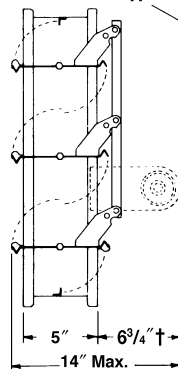
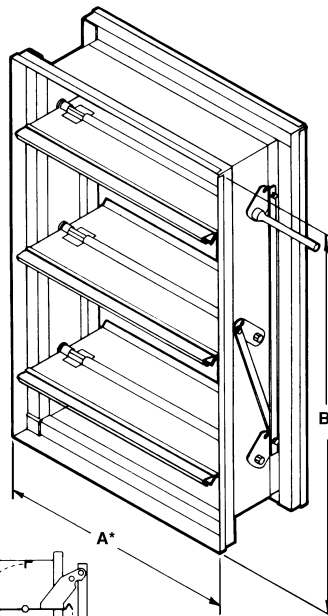

PARALLEL BLADE DEPICTED
Optional Exposed Linkage.

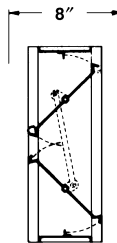

OPPOSED BLADE
Low profile frame illustrated is typical for units under 13" high.

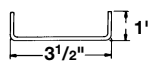

Heavy Construction/ Special Materials U-channel Frame Option

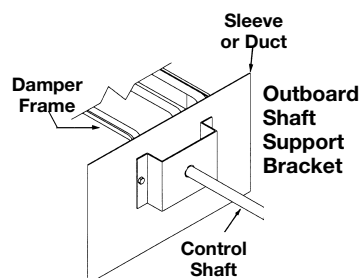

FEATURES

The C302 offers sturdy, steel construction with interlocking frame design. Damper locks together without bolts, screws, or rivets that could shake loose. Frame corners are internally braced to reduce racking.

Axles positively lock to blades without screws or welds. Non-stick, non-corrosive bearings assure long life and ease of operation. Axles and bearings combine with a shake proof linkage for low maintenance operation.

When tested in accordance with AMCA Standard 500, the reasonably priced C302 also exhibits low leakage rates that meet the frequently specified, 10 CFM/sq. ft. at 4" w.g. level.

PERFORMANCE DATA

The C302 is structurally designed for velocities to 2000 FPM and above. Turbulence may produce objectionable noise in some conditions with velocities above 1500 FPM.

Dampers may tolerate higher pressures and velocities than those listed here. Conservative ratings are presented intentionally in an effort to avoid misapplication. Consult Lau or your Lau representative when a damper is to be applied in conditions exceeding recommended maximums.

Damper Width	Maximum System Pressure	Maximum System Velocity	Leakage*	
			% OF MAX. FLOW	CFM/sq. ft.
48"	2.5" w.g.	1500 FPM	0.25	3.7
36"	3.0" w.g.	1500 FPM	0.25	3.7
24"	4.0" w.g.	1500 FPM	0.32	4.8
12"	5.0" w.g.	1500 FPM	0.47	7.0

*Leakage information based on pressure differential of 1" w.g. tested per AMCA Publication 500.

INSTALLATION

C302 IS NOT RECOMMENDED FOR INSTALLATION WITH BLADES RUNNING VERTICALLY.

For proper installation, damper must be installed square and free from racking. Actuator must be installed on linkage side. Opposed blade dampers must be operated from a power blade or shaft. See "Induct Mount Control Dampers Installation Instructions" for details.

BRACING OF MULTIPLE SECTION DAMPER ASSEMBLIES

The C302 is intended to be self supporting only in its largest single section size. Multiple section damper assemblies may require bracing to support the weight of the assembly and to hold against system pressure. Lau recommends appropriate bracing to support the damper horizontally at least once for every 8' of damper width. Vertical assemblies and higher system pressures may require more bracing.



*Units furnished approximately 1/4" smaller than given opening dimensions.

COMMERCIAL CONTROL DAMPERS



C306 High Performance Airfoil, Low Leakage

STANDARD CONSTRUCTION

FRAME

5" x 1" x 16 gauge galvanized steel hat channel reinforced with corner braces for structural strength equal to 11 gauge (channel frames. Low profile 3 1/2" x 3/8" x 16 gauge galvanized steel channel top and bottom frame on dampers under 12" high.

BLADES

Galvanized steel airfoil shaped, double skin construction of 14 gauge equivalent thickness, 6" wide. Parallel or opposed action.

SEALS

Ruskiprene blade edge seals and flexible metal compressible jamb seals.

BEARINGS

Stainless steel sleeve.

LINKAGE

Concealed in frame.

AXLES

1/2" plated steel hex.

CONTROL SHAFT

6" x 1/2" diameter, removable. Outboard shaft support bracket supplied with all single section dampers for field mounted actuators. Factory-installed jackshaft supplied with all multiple section dampers.

FINISH

Mill.

MAXIMUM SIZE

Single section – 60" w x 72" h
Multiple section assembly – Unlimited size.

MINIMUM SIZE

Single blade – 8" w x 6" h
Two blades, parallel or opposed action: 8" w x 11" h.

TEMPERATURE LIMITS

-72°F minimum and +275°F maximum.

VARIATIONS

Variations to the C306 basic design are available at additional cost, they include:

- Factory-installed, pneumatic and electric actuators (specific information required with order).
- SP100 Switch Package to remotely indicate damper blade position.
- Heavier frame construction with U-channel frame.
- Front, rear or double flange frame with or without bolt holes.

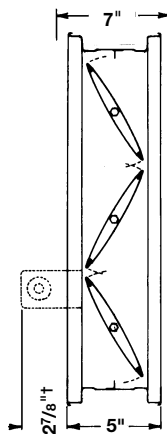
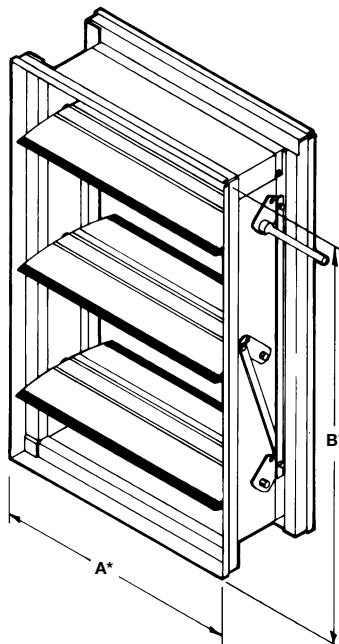

OPPOSED BLADE

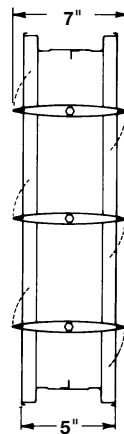

PARALLEL BLADE

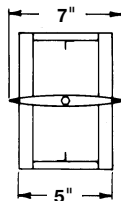

Low profile frame illustrated is typical for units under 12" high.

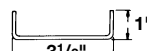

Heavy Construction/ Special Materials U-channel Frame Option

FEATURES

- The C306 offers sturdy, steel construction with interlocking frame design. Damper locks together without bolts, screws, or rivets that could shake loose. Frame corners are internally braced to reduce racking.
- Axles positively lock to blades without screws or welds. Non-stick, non-corrosive bearings assure long life and ease of operation. Axles and bearings combine with a shake proof linkage for low maintenance operation.
- Airfoil blade design and linkage concealed in the frame out of the air stream to reduce turbulence for low pressure drop and noise generation.
- Ruskiprene blade edge seals mechanically locked into the blade for superior low leakage in the closed position.

INSTALLATION

C306 IS NOT RECOMMENDED FOR INSTALLATION WITH BLADES RUNNING VERTICALLY.

If vertical blade application required, thrust collars and special construction necessary. Consult factory.

For proper installation, damper must be installed square and free from racking. Actuator must be installed on linkage side. Opposed blade dampers must be operated from a power blade or shaft. See "Induct Mount Control Dampers Installation Instructions" for details.

BRACING OF MULTIPLE SECTION DAMPER ASSEMBLIES

The C306 is intended to be self supporting only in its largest single section size. Multiple section damper assemblies may require bracing to support the weight of the assembly and to hold against system pressure. Lau recommends appropriate bracing to support the damper horizontally at least once for every 8' of damper width. Vertical assemblies and higher system pressures may require more bracing.

Pressure /Class	Leakage, Ft ³ /Min/Ft ² (L/S/M ²)			
	Required Rating		Extended Ranges (opt.)	
	1" W.G.	4" W.G.	8" W.G.	12" W.G.
1A	3 CFM	8 CFM	11 CFM	14 CFM
1	4 CFM	8 CFM	11 CFM	14 CFM
2	10 CFM	20 CFM	28 CFM	35 CFM
3	40 CFM	80 CFM	112 CFM	140 CFM

Damper Width	1" W.G.	4" W.G.	8" W.G.	12" W.G.
12"	IA	IA	IA	IA
24"	IA	IA	IA	—
36"	IA	IA	IA	—
48"	IA	IA	—	—
60"	IA	—	—	—



*Units furnished approximately 1/4" smaller than given opening dimensions.

†Jackshaft used only on multiple section dampers.

Leakage testing conducted in accordance with AMCA Standard 500-D-98. Torque applied holding damper closed, 5" lbs./ft. on opposed blade dampers and 7" lbs./sq. ft. on parallel blade dampers. Air leakage is based on operation between 50°F to 104°F. All data corrected to represent standard air density 0.075 lbs./ft³.

Specifications are subject to change without notice or obligation

C306 PERFORMANCE DATA

The actual pressure drop through a damper is the result of many factors. The formula and area factor table below may be used to estimate pressure drop for a C306 of a given size, with straight duct runs upstream and downstream, as in AMCA Figure 5.3.

C306 FREE AREA

Height Dim. B	Dimension A – Width In Inches													
	8"	12"	16"	20"	24"	28"	32"	36"	40"	44"	48"	52"	56"	60"
8"	0.17	0.29	0.42	0.54	0.67	0.79	0.92	1.04	1.17	1.29	1.42	1.54	1.67	1.79
10"	0.22	0.37	0.53	0.69	0.85	1.01	1.17	1.33	1.49	1.65	1.81	1.97	2.13	2.29
12"	0.29	0.51	0.72	0.94	1.15	1.37	1.58	1.80	2.01	2.23	2.44	2.66	2.87	3.09
14"	0.33	0.57	0.81	1.06	1.30	1.54	1.79	2.03	2.27	2.51	2.76	3.00	3.24	3.49
16"	0.40	0.70	1.00	1.30	1.60	1.89	2.19	2.49	2.79	3.09	3.39	3.69	3.99	4.28
18"	0.45	0.78	1.12	1.45	1.78	2.12	2.45	2.78	3.12	3.45	3.78	4.12	4.45	4.78
20"	0.52	0.91	1.30	1.69	2.08	2.47	2.86	3.25	3.63	4.02	4.41	4.80	5.19	5.58
24"	0.66	1.12	1.60	2.08	2.56	3.04	3.52	4.00	4.48	4.96	5.44	5.92	6.39	6.87
28"	0.77	1.34	1.90	2.47	3.04	3.61	4.18	4.75	5.32	5.89	6.46	7.03	7.60	8.17
32"	0.91	1.60	2.28	2.96	3.64	4.32	5.00	5.68	6.36	7.04	7.72	8.40	9.08	9.76
36"	1.04	1.81	2.58	3.35	4.12	4.89	5.66	6.43	7.20	7.97	8.74	9.52	10.29	11.06
40"	1.16	2.02	2.88	3.74	4.60	5.46	6.32	7.19	8.05	8.91	9.77	10.63	11.49	12.35
44"	1.31	2.28	3.25	4.22	5.20	6.17	7.14	8.11	9.08	10.06	11.03	12.00	12.97	13.95
48"	1.43	2.49	3.55	4.62	5.68	6.74	7.80	8.87	9.93	10.99	12.05	13.12	14.18	15.24
52"	1.55	2.70	3.86	5.01	6.16	7.31	8.47	9.62	10.77	11.92	13.08	14.23	15.38	16.54
56"	1.70	2.96	4.23	5.49	6.75	8.02	9.28	10.55	11.81	13.07	14.34	15.60	16.87	18.13
60"	1.82	3.17	4.53	5.88	7.24	8.59	9.95	11.30	12.65	14.01	15.36	16.72	18.07	19.42
64"	1.94	3.39	4.83	6.27	7.72	9.16	10.61	12.05	13.50	14.94	16.39	17.83	19.27	20.72
68"	2.09	3.64	5.20	6.76	8.31	9.69	11.42	12.98	14.54	16.09	17.65	19.20	20.76	22.31
72"	2.21	3.86	5.50	7.15	8.80	10.44	12.09	13.73	15.38	17.02	18.67	20.32	21.96	23.61

Formula

$$\Delta P = 1.45 \left[\frac{\text{CFM}}{\text{AREA FACTOR}} \cdot \text{Vel.} \right]^2 \div 4005$$

ΔP = Pressure drop in inches w.g.
 Vel. = Duct Velocity in ft. / min.
 CFM = Duct area in sq. ft. x velocity in FPM

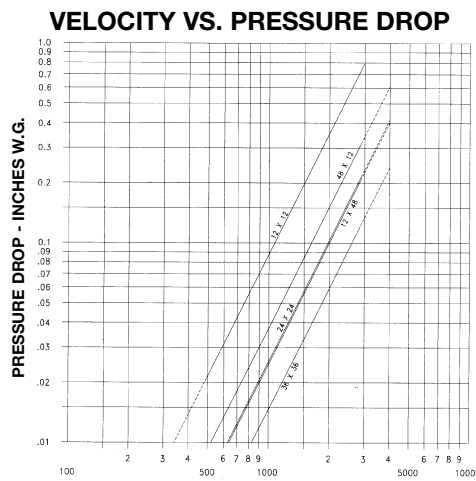

FACE VELOCITY - FEET/MINUTE — AMCA FIG. 5.3
 C306 sizes 12 x 12, 24 x 24, 48 x 12, 12 x 48, 36 x 36
 All data corrected to represent standard air at a density of 0.075 lbs/ft³.

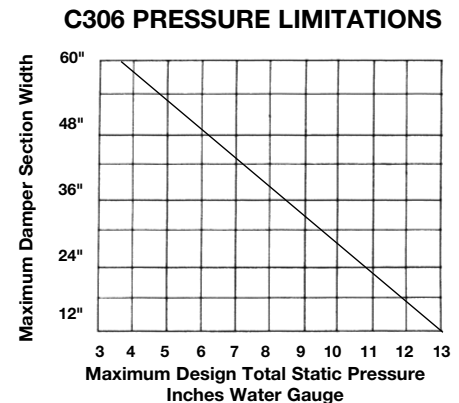

The C306 may be used in systems with total pressures exceeding 3.5" by reducing damper section width as indicated. Example: Maximum design total pressure of 8.5" w.g. would require C306 damper with maximum section width of 36".

Pressure limitations above allow maximum blade deflection of 1/180 of span on 60" damper widths. Deflections in other damper widths (less than 48" at higher pressures shown) will result in blade deflection substantially less than 1/180 of span.

Specifications are subject to change without notice or obligation

COMMERCIAL CONTROL DAMPERS



C350 Extruded Aluminum, Low Leakage

APPLICATION

The CD350 is a low leak, extruded aluminum damper designed with airfoil blades for higher velocity and pressure HVAC systems. It meets the leakage requirements of the International Energy Conservation Code by leaking less than 3 cfm/sq. ft. at 1" of static pressure and is AMCA licensed as a Class 1A damper.

STANDARD CONSTRUCTION

FRAME

5" x 1" x 6063T5 extruded aluminum hat channel with .125" minimum wall thickness. Low profile, 5" x 1/2" top and bottom frames on dampers 12" high and less. Mounting flanges on both sides of frame.

BLADES

6" wide, 6063T5 heavy gauge extruded aluminum, airfoil shape.

SEALS

Ruskiprene blade edge seals and flexible metal compressible jamb seals.

BEARINGS

Molded synthetic.

LINKAGE

Concealed in frame.

AXLES

1/2" plated steel hex.

MAXIMUM SIZE

Single section – 60"w x 72"h.
Multiple section assembly –
Unlimited size.

MINIMUM SIZE

Single blade – 6"w x 5"h.
Two blades, parallel or opposed
action: 6"w x 9"h.

TEMPERATURE LIMITS

-72°F and +275°F

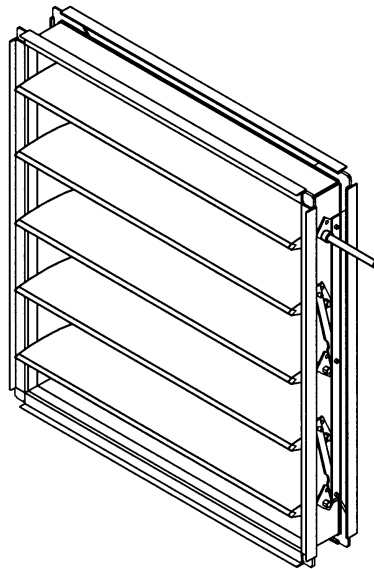

FEATURES

- Airfoil blade design for low pressure drop and less noise generation.
- Positive lock axles, noncorrosive bearings and shake proof linkage for low maintenance operation.
- Blade edge seals mechanically lock into the blade for superior sealing.

OPTIONS

- **Factory-installed**, pneumatic and electric actuators.
- Enamel and epoxy finishes.
- **SP100 Switch Package** to remotely indicate damper blade position.
- **16 gauge galvanized steel** hat channel frame.
- Front, rear or double flange frame with or without bolt holes.
- Face and bypass configurations.

SPECIFICATIONS

Furnish and install, at locations shown on plans, or in accordance with schedules, Low leakage dampers shall meet the following minimum construction standards: Frames shall be 5" x 1" x .125" (minimum thickness) 6063T5 extruded aluminum hat channel with hat mounting flanges on both sides of the frame. Each corner shall be reinforced with two die formed internal braces and machine staked for maximum rigidity. Blades shall be airfoil type extruded aluminum (maximum 6" depth) with integral structural reinforcing tube running full length of each blade.

Blade edge seals shall be extruded double edge design with inflatable pocket which enables air pressure from either direction to assist in blade to blade seal off. Blades seals shall be mechanically locked in extruded blade slots, yet shall be easily replaceable in field. Adhesive or clip-on type blade seals are not acceptable. Bearings shall be non-corrosive molded synthetic. Axles shall be hexagonal (round not acceptable) to provide positive locking connection to blades and linkage. Linkage shall be concealed in frame. Submittal must include leakage, maximum air flow and maximum pressure ratings based on AMCA Publication 500. Damper shall be tested and licensed in accordance with AMCA 511 for Air Performance and Air Leakage. Damper widths from 12" to 60" wide shall not leak any greater than 8 cfm sq. ft. at 4" w.g. and a maximum of 3 CFM sq. ft. at 1" w.g. Dampers shall be in all respects equivalent to Lau Model CD350.

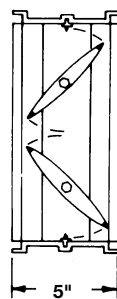
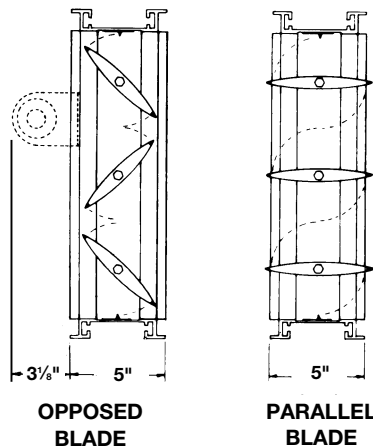

LOW PROFILE
Standard construction
for higher free area on
dampers 12" high and less.

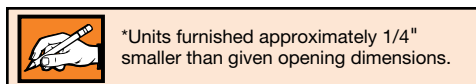
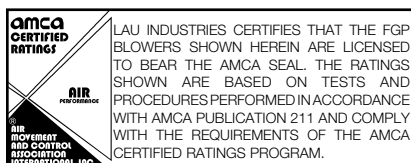

Specifications are subject to change without notice or obligation

C350 Extruded Aluminum, Low Leakage

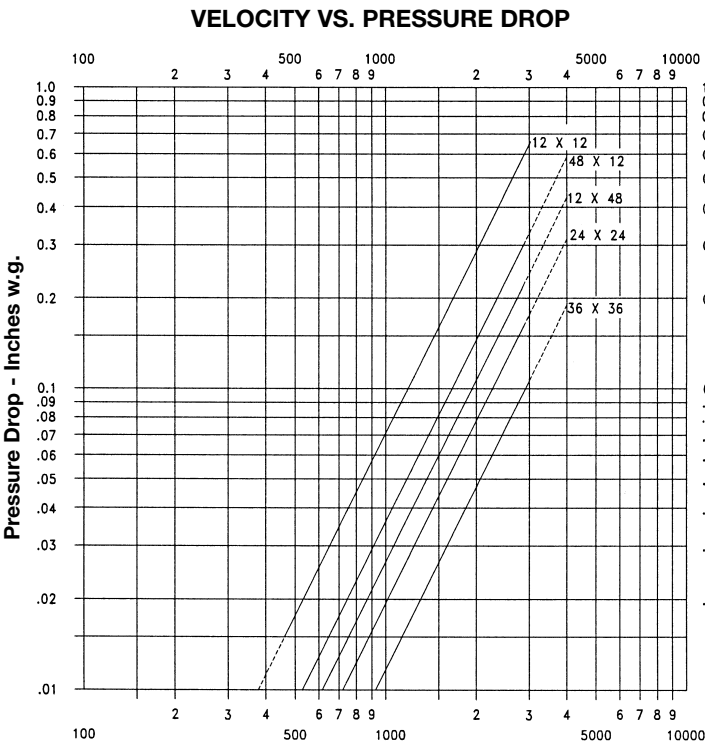

FACE VELOCITY - FEET/MINUTE (AMCA FIG. 5.3)

CD350 sizes 12 x 12, 24 x 24, 48 x 12, 12 x 48, 36 x 36
All data corrected to represent standard air at a density of 0.075 lbs/ft³

CD350 SOUND RATINGS

Damper Size	Damper Full Open		Damper 75% Open		Damper 50% Open		Damper 25% Open	
	CFM	NC	CFM	NC	CFM	NC	CFM	NC
12 x 12	2000	17	1500	11	1000	11	500	*
	3000	28	2250	22	1500	19	750	*
	4000	35	3000	29	2000	24	1000	*
18 x 18	2250	17	1688	10	1125	21	563	*
	4500	33	3375	26	2250	32	1125	*
	6750	43	5063	37	3375	40	1688	15
24 x 24	4000	11	3000	10	2000	26	1000	*
	8000	32	6000	30	4000	38	2000	21
	12000	43	9000	42	6000	46	3000	31

NC = Noise criteria in Decibels is based on 10db room effect and 10db of room attenuation.

* = Less than 10 NC

See ASHRAE Handbook (1977 Fundamentals, Chapter 7) for explanation of NC Ratings.

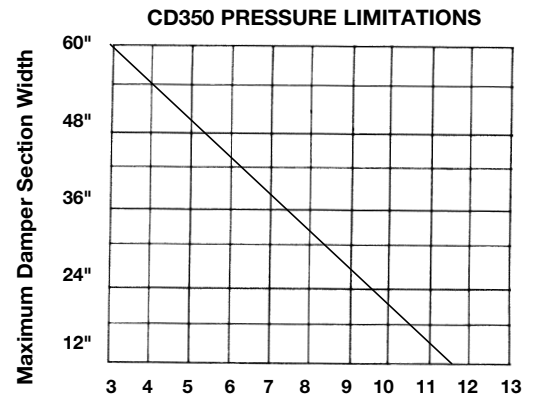

The CD350 may be used in systems with total pressures exceeding 3.5" by reducing damper section width as indicated.

Example: Maximum design total pressure of 8.5" w.g. would require CD350 damper with maximum section width of 36".

Pressure limitations shown above allow maximum blade deflection of 1/180 of span on 60" damper widths. Deflections in other damper widths (less than 48") at higher pressures shown will result in blade deflection substantially less than 1/180 of span.

Pressure /Class	Leakage, Ft ³ /Min/Ft ² (L/S/M ²)			
	Required Rating		Extended Ranges (opt.)	
	1" W.G.	4" W.G.	8" W.G.	12" W.G.
1A	3 CFM	NA	NA	NA
1	4 CFM	8 CFM	11 CFM	14 CFM
2	10 CFM	20 CFM	28 CFM	35 CFM
3	40 CFM	80 CFM	112 CFM	140 CFM

Damper Width	1" W.G.	4" W.G.	8" W.G.
12"	IA	I	II
24"	IA	I	II
36"	IA	I	NA
48"	IA	I	NA
60"	IA	I	NA

Leakage testing conducted in accordance with AMCA Standard 500-D-98. Torque applied holding damper closed, 5 in. lbs./sq. ft. on opposed blade dampers and 7 in. lbs./sq. ft. on parallel blade dampers. Air leakage is based on operation between 50°F to 104°F. All data corrected to represent standard air density 0.075 lbs/ft³.

COMMERCIAL CONTROL DAMPERS



C301 Standard Galvanized Steel

STANDARD CONSTRUCTION

FRAME

5" x 1" x 16 gauge galvanized steel hat channel reinforced with corner braces for structural strength equal to 13 gauge channel frames. Low profile 3 1/2" x 3/8" x 16 gauge galvanized steel channel top and bottom frame on dampers under 13" high.

BLADES

6" wide, 16 gauge galvanized steel blades approximately 6" on center. Parallel or opposed action.

BEARINGS

Synthetic.

LINKAGE

Concealed in frame. Exposed linkage optional.

AXLES

1/2" plated steel hex.

CONTROL SHAFT

6" x 1/2" diameter. Outboard support bearing supplied with all single section dampers for field mounted actuators. Factory-installed jackshaft supplied with all multiple section dampers.

FINISH

Mill.

MAXIMUM SIZE

Single section – 48" w x 72" h
Multiple section assembly – Unlimited size.

MINIMUM SIZE

Single blade – 5" w x 5" h
Two blades, parallel or opposed action, exposed linkage – 8" w x 14" h
Two blades, parallel or opposed action, concealed linkage – 5" w x 10" h.

TEMPERATURE LIMITS

-40°F (-40°C) minimum and +240°F (+116°C) maximum.

Maximum section width varies with static pressure. Consult Lau if application involves pressures in excess of 2.5 inches w.g. or air velocities in excess of 2000 FPM.

VARIATIONS

Variations to standard C301 construction available at additional cost are:

- Polyurethane foam blade seals.
- Flexible, metal compression type jamb seals.
- Heavier construction.
- Stainless steel construction.
- Factory-installed, pneumatic and electric actuators (specific information required with order).
- SP100 Switch Package to remotely indicate damper blade position.
- Front, or rear flange frame with or without bolt holes.

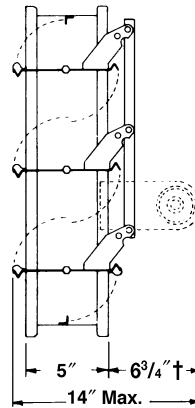
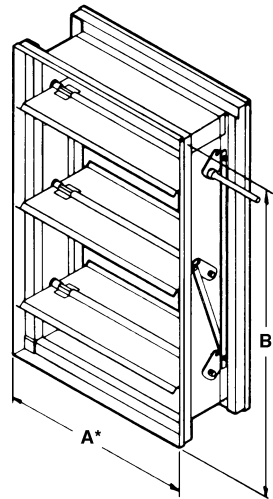

PARALLEL BLADE DEPICTED
Optional Exposed Linkage.

FEATURES

The C301 offers sturdy, steel construction with interlocking frame design. Damper locks together without bolts, screws, or rivets that could shake loose. Frame corners are internally braced to reduce racking.

Axles positively lock to blades without screws or welds. Non-stick, non-corrosive bearings assure long life and ease of operation. Axles and bearings combine with a shake proof linkage for low maintenance operation.

PERFORMANCE DATA

The C301 is structurally designed for velocities to 2000 FPM and above. Turbulence may produce objectionable noise in some conditions with velocities above 1500 FPM.

Dampers may tolerate higher pressures and velocities than those listed here. Conservative ratings are presented intentionally in an effort to avoid misapplication. Consult Lau or your Lau representative when a damper is to be applied in conditions exceeding recommended maximums.

Damper Width	Maximum System Pressure	Maximum System Velocity	Leakage with Seals*		Leakage without Seals*	
			% of max. flow	CFM/sq. ft.	% of max. flow	CFM/sq. ft.
48"	2.5" w.g.	1500 FPM	0.67	10	2.67	40
36"	3.0" w.g.	1500 FPM	0.67	10	2.67	40
24"	4.0" w.g.	1500 FPM	0.80	12	3.33	50
12"	5.0" w.g.	1500 FPM	1.13	17	4.33	65

*Leakage information based on pressure differential of 1" w.g. tested per AMCA Publication 500.

INSTALLATION

C301 IS NOT RECOMMENDED FOR INSTALLATION WITH BLADES RUNNING VERTICALLY. For proper installation, damper must be installed square and free from racking. Actuator must be installed on linkage side. Opposed blade dampers must be operated from a power blade or shaft. See "Induct Mount Control Dampers Installation Instructions" for details.

BRACING OF MULTIPLE SECTION DAMPER ASSEMBLIES

The C301 is intended to be self supporting only in its largest single section size. Multiple section damper assemblies may require bracing to support the weight of the assembly and to hold against system pressure. Lau recommends appropriate bracing to support the damper horizontally at least once for every 8' of damper width. Vertical assemblies and higher system pressures may require more bracing.

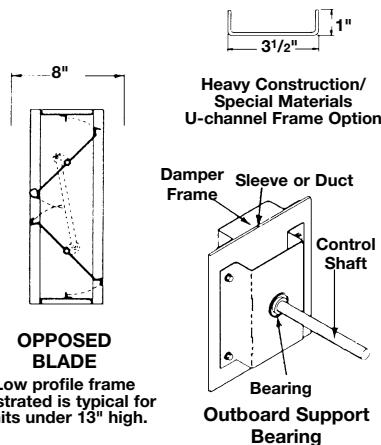

* Units furnished approximately 1/4" smaller than given opening dimensions.
† Jackshaft used only on multiple section dampers.

CRS25 Round, Low Leakage

STANDARD CONSTRUCTION

FRAME

20 gauge galvanized steel up to 24" diameter, 7" long.

BLADE

Two layers of galvanized steel; 14 gauge equivalent thickness.

BLADE SEAL

Polyethylene foam seal sandwiched between two sides of blades. Seal fully encompasses blade edge.

AXLE

1/2" diameter.

BEARING

Stainless steel sleeve pressed into frame.

CONTROL SHAFT

Axle extends 6" beyond frame exterior.

FINISH

Mill galvanized.

DAMPER SIZES

(D Diameter) 4", 5", 6", 8", 9", 10", 12", 14", 16", 18", 20", 22", and 24".

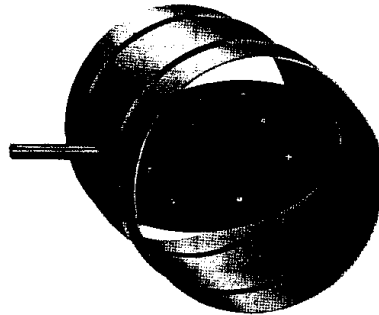

FEATURES

The CRS25 was developed in response to industry requirements for a low leakage butterfly damper, which easily installs in round spiral duct work. The specially designed blade-to-frame polyethylene foam seal is sandwiched between two round blades and fully encompasses the blade edge. The CRS25 can be optionally furnished with a variety of manual, pneumatic, or electric actuators (fail-safe spring return or double action). A leakage rating of .15 SCFM per inch of perimeter at 4" w.g. as well as pressure differentials up to 6" w.g. apply to CRS25 dampers produced to standard manufacturing tolerances.

STATIC PRESSURE IN INCHES W.G.

DIMENSION D (Diameter)	MIN. IN. LBS. TORQUE AT 2" w.g. OR LESS STATIC PRESSURE
4"	36
5"	40
6"	44
7"	48
8"	52
9"	56
10"	60
12"	68
14"	76
16"	84
18"	92
20"	100
22"	108
24"	116

Static Pressure Drop Chart

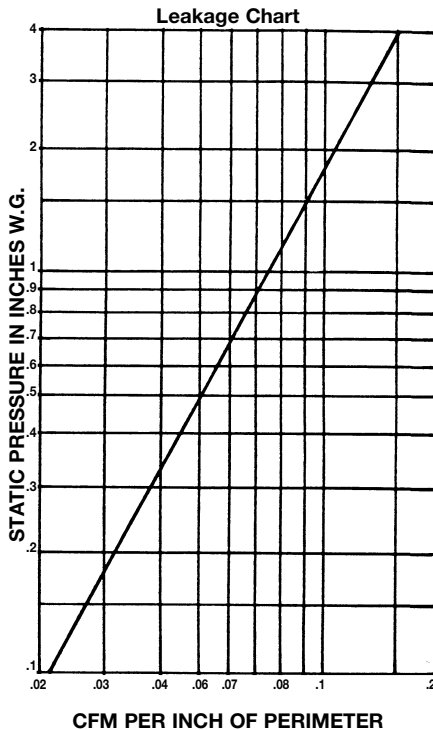
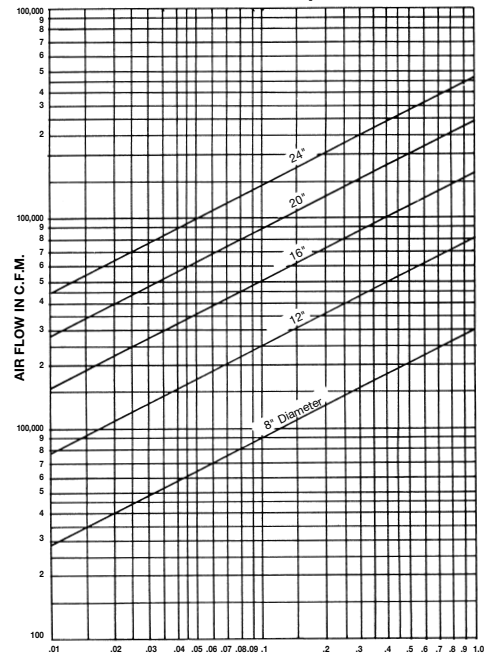

DETERMINING LEAKAGE

To determine damper leakage, enter Damper Leakage chart from the left side. Given the static pressure the damper will encounter in closed position, move horizontally to diagonal line, then go straight down the chart to CFM of leakage per inch of perimeter.

Example: Damper operating at 1.5" w.g. static pressure will leak .09 CFM per inch of perimeter. Total leakage on an 8" round will be 8 x 3.14 x .09 CFM per inch perimeter = 2.26 CFM leakage.

DETERMINING STATIC PRESSURE DROP

To determine static pressure drop through an open damper, enter the Damper Pressure Drop chart from the left side. Given the CFM of air flow through the damper, follow the CFM line to the diagonal line with the damper size required, then down to the static pressure drop of the unit.

Example:

The pressure drop of an 8" damper with 700 CFM flow is .06" w.g.



1. Ratings are based on AMCA Standard 500 using Test Setup Apparatus Figure 5.3 (damper installed with duct upstream and downstream).

2. Static pressure and CFM are corrected to .075 lb./cu. ft. air density.

* Units furnished approximately 1/8" smaller than D diameter dimensions.

COMMERCIAL CONTROL DAMPERS



C305 Heavy Duty

STANDARD CONSTRUCTION

FRAME

5" x 1" x 16 gauge galvanized steel channel with corner braces. Low profile top and bottom 3 1/2" x 3/8" x 16 gauge galvanized steel channel units under 13" high.

BLADES

8" maximum width 16 gauge galvanized steel. Opposed blade action is standard with parallel blade action optional at no additional charge.

FINISH

Mill galvanized.

LINKAGE

Exposed or concealed in frame as determined by Lau.

AXLES

1/2" hex.

BEARINGS

Molded synthetic.

CONTROL SHAFT

3" x 3/8" square plated steel. 1/2" jackshaft for multi-section dampers.

MAXIMUM SIZE

Single section – 48" w x 48" h – dampers under 10 3/8" nominal are single blade.

MULTIPLE SECTION ASSEMBLY

96" w x 96" h. Each section operates independently. Requires one hand quadrant per section. For larger sizes see Model C301.

MINIMUM SIZE

6" w x 5" h

TEMPERATURE LIMITS

-40°F (-40°C) minimum and +240°F (+116°C).

VARIATION

Available at additional cost:

- Locking hand quadrant.
- 2" stand-off hand quadrant mounting bracket (ship loose) (does not include hand quadrant).
- 1/2" round control shaft.
- Oilite bronze bearings.

PERFORMANCE DATA

The C305 is structurally designed for velocities to 2000 FPM and above. Turbulence may produce objectionable noise in some conditions with velocities above 1500 FPM.

Dampers may tolerate higher pressures and velocities than those listed here. Conservative ratings are presented intentionally in an effort to avoid misapplication. Consult Lau or your Lau representative when a damper is to be applied in conditions exceeding recommended maximums.

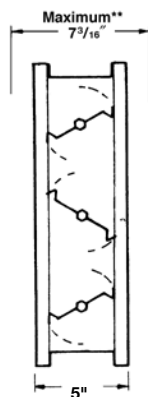
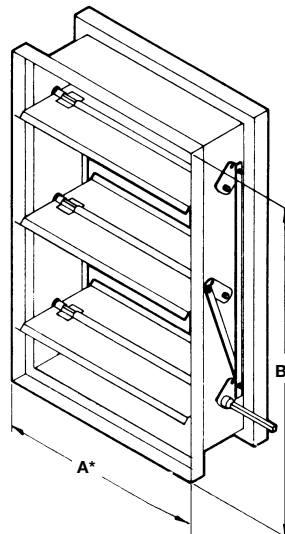

C305/OB OPPOSED BLADE

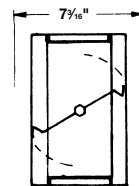

C305 SINGLE BLADE
Low profile top and bottom illustrated. Typical units under 13" high nominal.

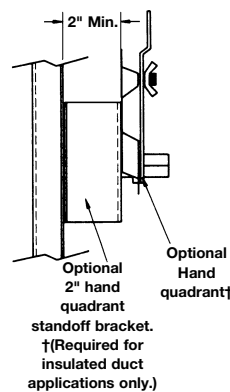

Optional 2" hand quadrant standoff bracket. †(Required for insulated duct applications only.)

FEATURES

Lau's C305 is a ruggedly built damper designed especially for manual balancing applications. It offers an economical manufactured product alternative to the "shop built" items often installed.

Features available with other commercial control dampers are standard with the C305. Non-stick, non-corrosive bearings assure long damper life and ease of operation. Linkage is shake proof and low maintenance. Hex axles lock positively with blades, without screws or welds that might shake loose. Steel frame design interlocks without bolts, screws or rivets and features internally braced corners to reduce racking.

Lau's C305 exceeds the volume damper designs recommended in SMACNA HVAC Duct Construction Standards (Metal and Flexible).



For proper operation, dampers must be installed square and free from racking. C305 is intended for reduced volume control, not positive shut off. It is not recommended for application as an automatic control damper.

BRACING OF MULTIPLE SECTION DAMPER ASSEMBLIES

The C305 is intended to be self supporting only in its largest single section size. Multiple section damper assemblies may require bracing to support the weight of the assembly and to hold against system pressure. Lau recommends appropriate bracing to support the damper horizontally at least once for every 8' of damper width. Vertical assemblies and higher system pressures may require more bracing.

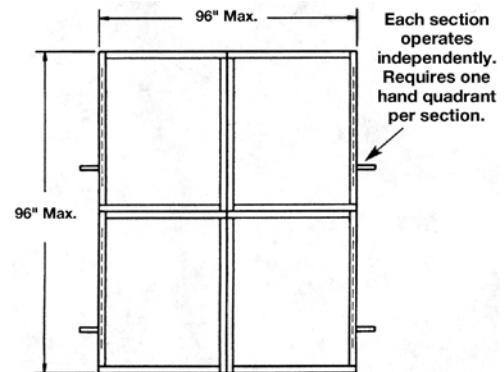

Damper can be provided with optional jackshaft for operation from one side.

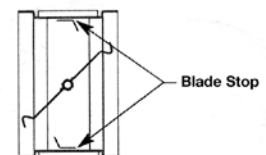

C305
Blade Stop is standard for units 12" high and under. Blade Stop is optional for units over 12" high.

Damper Width	Maximum System Pressure	Maximum System Velocity
48"	2.5" w.g.	1500 FPM
36"	3.0" w.g.	1500 FPM
24"	4.0" w.g.	1500 FPM
12"	5.0" w.g.	1500 FPM



† Items are shipped loose for field installation.
*Unit furnished approximately 1/4" smaller than given dimensions.

Specifications are subject to change without notice or obligation

STANDARD CONSTRUCTION

FRAME

22 gauge galvanized steel 3" or 5" x 1" x 18 gauge galvanized steel channel with corner braces.

BLADES

22 gauge galvanized steel single blade or 18 gauge galvanized. 8" maximum width.

FINISH

Mill galvanized.

LINKAGE

Concealed in frame for units over 36" w x 12" h

AXLES

3/8" square or 1/2" hex.

BEARINGS

Molded synthetic.

CONTROL SHAFT

3" x 3/8" square plated steel with 2" standoff bracket and locking hand quadrant.

MINIMUM SIZE

5" w x 4" h

MAXIMUM SIZE

48" w x 48" h – Dampers larger than 36" w or 12" h will be built as multiple section dampers.

TEMPERATURE

-40°F (-40°C) minimum and +240°F (+116°C).

PRESSURE RATING

48" wide 2 1/2" SP. at 1,500 FPM

VARIATIONS

Available at additional cost:

- 1/2" round control shaft.
- Oilite bronze bearings.

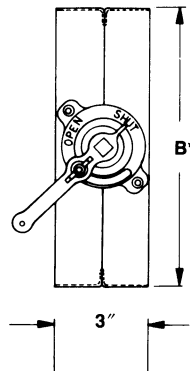

FEATURES

Lau's C315 is a ruggedly built, inexpensive damper with standoff bracket for the hand quadrant both factory furnished. The C315 is designed especially for manual balancing applications with rectangular duct work.

- Easy to install.
- Becomes part of the duct work.
- Offers an economical alternative to a "shop built" damper.



* Unit furnished approximately 1/4" smaller than given dimensions.

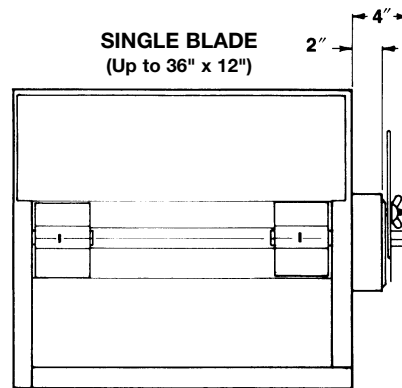

2" hand quadrant
stand-off bracket

MULTI- BLADE

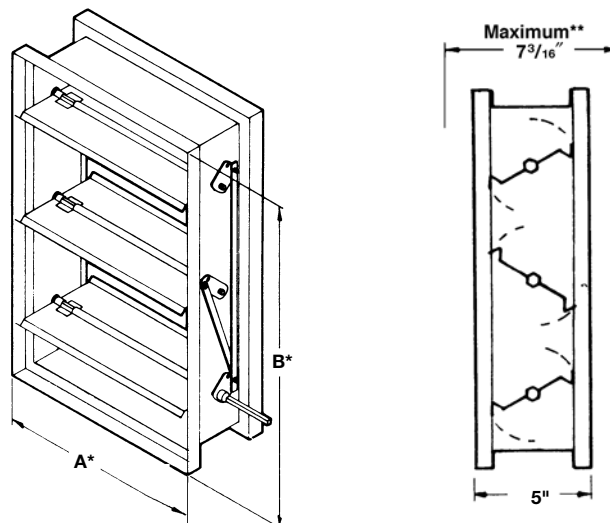

Specifications are subject to change without notice or obligation

MANUAL BALANCING DAMPERS



C310 Single Blade

STANDARD CONSTRUCTION

FRAME

22 gauge galvanized steel, 3" wide.

BLADES

22 gauge galvanized steel.

CONTROL SHAFT/HAND QUADRANT

3/8" square axle shaft, extending beyond frame with factory supplied, locking hand quadrant for field mounting.

BEARINGS

Molded synthetic

FINISH

Mill galvanized

MAXIMUM VELOCITY

1500 FPM

MAXIMUM TEMPERATURE

250°F (121°C)

MINIMUM SIZE (A X B)

5"w x 4"h

MAXIMUM SIZE (A X B)

36"w x 12"h. For unit requirements above 12" high, see C305.

VARIATION

Variations to standard construction available at additional cost are:

- Oilite bearings.
- 2" hand quadrant stand-off bracket.
- SMACNA construction on units greater than 19" wide, includes 16 gauge blades and 1/2" axles.

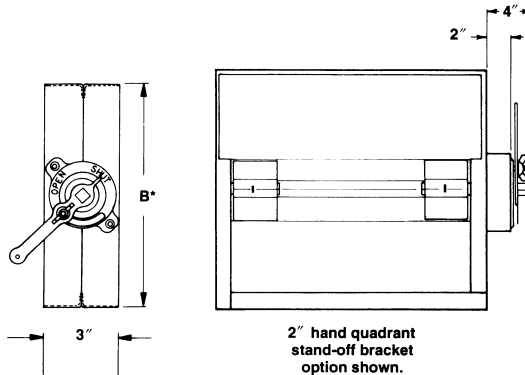
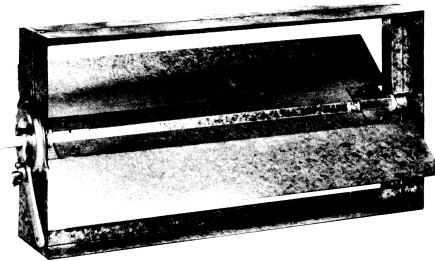

FEATURES

The C310 is a ruggedly built, inexpensive damper with factory furnished, locking hand quadrant designed especially for manual balancing applications with rectangular duct work.

- Easy to install.
- Becomes part of the duct work.
- Offers an economical alternative to a "shop built" damper.
- Meets SMACNA Standards for single blade volume dampers under 19" wide and over 19" wide with optional features.

MANUAL BALANCING DAMPERS

CR307 Single Blade

STANDARD CONSTRUCTION

FRAME

20 gauge galvanized steel, 7" wide.

BLADES

20 gauge galvanized steel.

CONTROL SHAFT/HAND QUADRANT

3/8" square axle shaft extending beyond frame through factory mounted, locking hand quadrant.

BEARINGS

Molded synthetic.

FINISH

Mill galvanized.

MAXIMUM VELOCITY

1500 FPM.

MAXIMUM TEMPERATURE

250°F (121°C).

DAMPER SIZES

4", 5", 6", 7", 8", 9", 10", 12", 14", 16", 18" and 20" diameters (D).

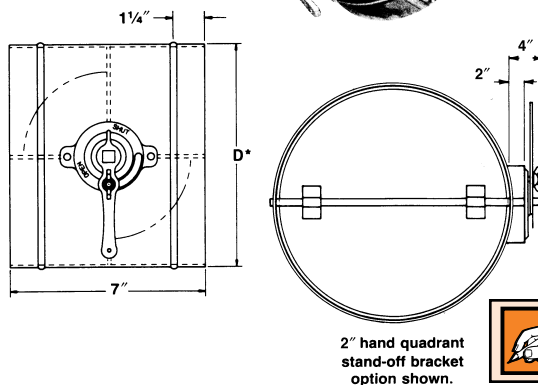

VARIATION

Variations to standard construction available at additional cost are:

- Oilite bearings.
- 2" hand quadrant stand-off bracket.

FEATURES

The CR307 is a ruggedly built damper with factory mounted, locking hand quadrant designed especially for manual balancing applications within round spiral duct work. It is easy to install and seal, becomes part of the duct work and offers an economical alternative to a "shop built" damper.



*Units furnished approximately 1/4" smaller than given opening dimensions.

Specifications are subject to change without notice or obligation

C400 Galvanized

STANDARD CONSTRUCTION

FRAME

20 gauge galvanized steel.

BLADES

28 gauge galvanized steel.

BLADE SEAL

Extruded vinyl seal mechanically locked into blade edges.

AXLES

Damper sections up to 42" wide: Zytel synthetic axle assembly mechanically locked onto blade edge. Damper assemblies larger than 42" wide: stainless steel axle and blade bracket assembly.

LINKAGE

Damper sections up to 24" wide: galvanized steel single tie bar linkage. Damper sections larger than 24" wide: galvanized steel double tie bar linkage.

FINISH

Mill.

TEMPERATURE LIMITS

-40°F to +200°F (-40°C to 94°C).

MINIMUM SIZE

8" x 8".

MAXIMUM SIZE

Single Section –

42" x 64" with standard construction.
40" x 48" with aluminum blades.

Multiple Section Assembly –

Unlimited Size.

VARIATIONS

- Counterweights and spring-assist kits for vertical airflow and extremely low pressure reliefs
- Electric actuators
- Chain pulls
- Sleeves
- Aluminum blades**
- Front or rear screens



* Unit furnished approximately 1/4" smaller than given dimensions.

** See Maximum Velocity for Aluminum Blade Units to the right.

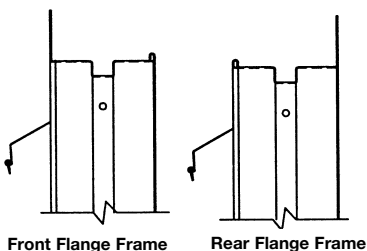

Front Flange Frame

Rear Flange Frame

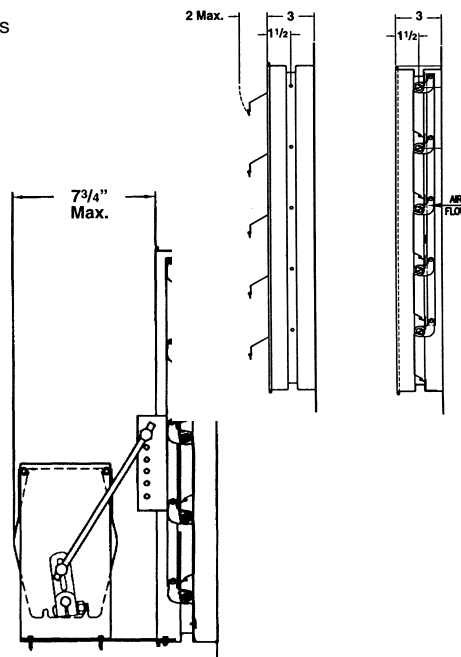
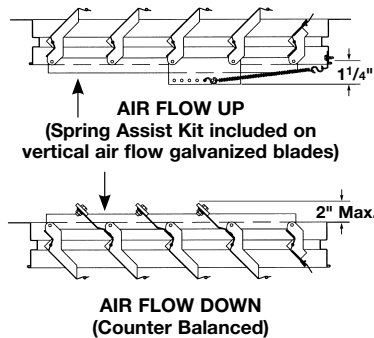
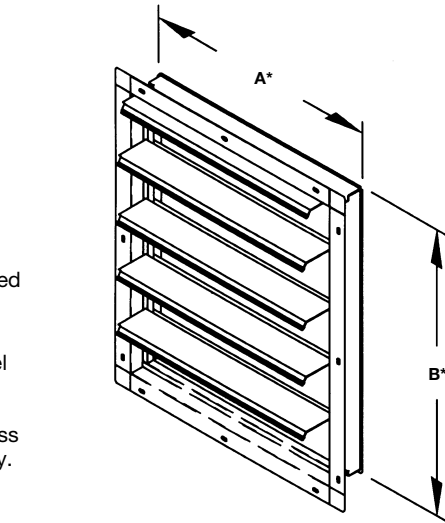

Internal Mounted Actuator

FEATURES

- Wide operating range – velocities up to 3000 FPM (refer to maximum velocity tables).
- Corrosion resistant galvanized steel construction, standard.
- Blade design for weather protection and leakage.
- Pre-punched mounting holes in flange frame units.
- Mechanically locked blade seals.

PERFORMANCE DATA

AIR VELOCITY (FPM) THROUGH DAMPER FACE AREA	STATIC PRESSURE DROP (INCHES W.G.)
600	.110
800	.110
1000	.075
1200	.070
1500	.100
1800	.140
2000	.180
2500	.290
3000	.390

C400 PRESSURE DROP

Based on 36" x 36" unit.

MAXIMUM VELOCITY FOR STANDARD GALVANIZED STEEL BLADE UNITS

DAMPER WIDTH	MAXIMUM FPM	
	STAINLESS STEEL AXLES	PLASTIC (ZYTEL) AXLES
8" - 24"	3,000	3,000
Over 24" - 36"	3,000	1,200
Over 36" - 42"	1,500	1,200

Units larger than 42" wide will be a one-piece unit with center mullion up to 72" w x 64" h, and multi-section assemblies for dampers larger than 72" wide.

MAXIMUM VELOCITY FOR ALUMINUM BLADE UNITS

DAMPER WIDTH	MAXIMUM FPM	
	STAINLESS STEEL AXLES	PLASTIC (ZYTEL) AXLES
8" - 24"	3,000	3,000
Over 24" - 36"	2,500	1,000
Over 36" - 40"	1,500	1,000

Units larger than 40" wide will be assembled as a multi-section unit.

Specifications are subject to change without notice or obligation

BACKDRAFT DAMPERS



C401 & C402 Aluminum Light and Medium Duty

STANDARD CONSTRUCTION

FRAME

6063T5 extruded aluminum, .090" wall thickness, mitered corners.

BLADES

C401 – .025 formed aluminum, extruded vinyl edge seals.
C402 – 6063T5 extruded aluminum, .050" wall thickness, extruded vinyl edge seals.

BEARINGS

Synthetic.

LINKAGE

Concealed in frame.

FINISH

Mill.

TEMPERATURE LIMITS

-40°F to +200°F (-40°C to +93°C).

MAXIMUM SPOT VELOCITY

C401 – 1500 FPM.
C402 – 2500 FPM.

MINIMUM SIZE

6"w x 6"h

MAXIMUM SIZE

Single section – 40" w x 48" h

NOTE:

When used in fan discharge applications, damper should be located at a minimum distance equal to half the fan diameter away from the fan discharge.

VARIATIONS

The following variations to the C401 and C402 are available at additional cost:

- Rear mounted screen
- Special finishes
- Electric actuators

INSTALLATION

For proper operation, the damper must be installed square and free from racking.

The C401 and C402 is intended to be self supporting only in the largest single section size. Multiple section damper assemblies may require bracing to support the weight of the assembly and to hold against system pressure.

Lau recommends appropriate bracing to support the weight of the assembly and to hold against system pressure.

Lau recommends appropriate bracing to support the damper horizontally at least once for every 8' of damper width. Vertical assemblies and higher system pressures may require more bracing.

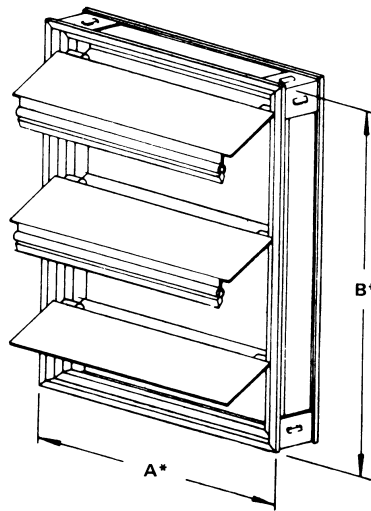

FEATURES

The C401 and C402 dampers offer backdraft protection in light to medium duty applications that demand less than 12 CFM per square foot of leakage at 1/2" w.g. Non-metallic blade-to-blade seal provides quiet operation during the highest spot velocities.

The damper's good looking appearance is maintained by sturdy, corrosion resistant aluminum construction. Contemporary styling features blades that overlap the frame for optimum resistance to weather.

PERFORMANCE DATA

AMCA Standard 500 provides a reasonable basis for testing and rating dampers. Testing to AMCA 500 is performed under a certain set of laboratory conditions. This does not guarantee that other conditions will not occur in the actual environment where dampers must operate.

Designs should provide a reasonable safety factor for damper performance by selecting at some point below damper leakage or pressure drop system requirements.

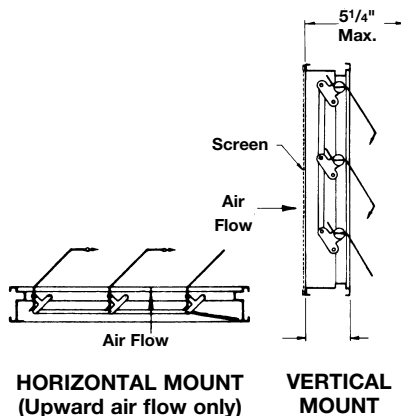

C401

DAMPER WIDTH	MAXIMUM BACK PRESSURE (EXTERNAL WIND VELOCITY)	MAXIMUM SYSTEM VELOCITY	LEAKAGE*	
			% OF MAX. FLOW	CFM/ SQ. FT.
40"	55 mph/1.5" w.g.	1000 FPM	1.5	15.0
36"	70 mph/2.5" w.g.	1000 FPM	1.5	15.0
24"	85 mph/3.5" w.g.	1000 FPM	2.0	20.0
12"	95 mph/4.5" w.g.	1000 FPM	4.0	40.0

C402

DAMPER WIDTH	MAXIMUM BACK PRESSURE (EXTERNAL WIND VELOCITY)	MAXIMUM SYSTEM VELOCITY	LEAKAGE*	
			% OF MAX. FLOW	CFM/ SQ. FT.
40"	75 mph/3" w.g.	1500 FPM	1.0	15.0
36"	90 mph/4" w.g.	1500 FPM	1.0	15.0
24"	100 mph/5" w.g.	1500 FPM	1.17	17.5
12"	100 mph/6" w.g.	1500 FPM	2.67	40.0

*Leakage information based on pressure differential of 1" w.g.

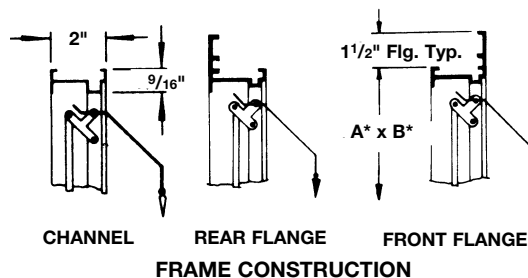

OPERATIONAL PRESSURES INCHES W.G.		
DAMPER MODEL	BLADES START TO OPEN	BLADES FULLY OPEN
C401	.03	.10
C402	.10	.15



*Units furnished approximately 1/4" smaller than given opening dimensions.

Specifications are subject to change without notice or obligation

C460 Aluminum Heavy Duty

STANDARD CONSTRUCTION

FRAME

6063T5 extruded aluminum, .125" wall thickness.

BLADES

6063T5 extruded aluminum, .070" wall thickness, extruded vinyl blade edge seals.

BEARINGS

Synthetic.

LINKAGE

1/2" tie bars.

FINISH

Mill.

TEMPERATURE LIMITS

-40°F to +200°F (-40°C to +93°C).

MAXIMUM SYSTEM VELOCITY

2500 FPM.

MAXIMUM SPOT VELOCITY

3500 FPM.

MINIMUM SIZE

6"w x 6"h

MAXIMUM SIZE

Single section – 48"w x 52"h

Multiple section assembly – Unlimited size.

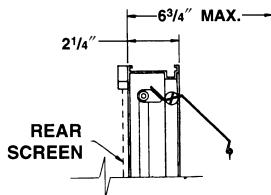
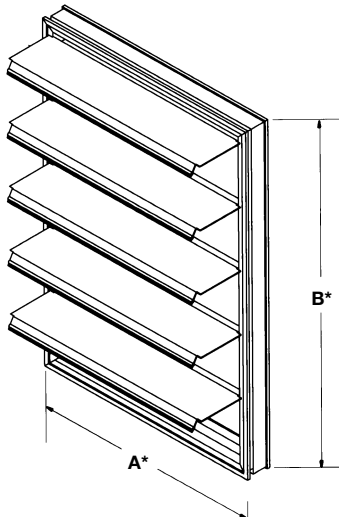

When used in fan discharge applications, damper should be located at a minimum distance equal to half the fan diameter away from the fan discharge.

VARIATIONS

The following variations to the C460 backdraft damper are available at additional cost:

- SPC static pressure control (one SPC per section)
- Rear or front mounted screen
- Special finishes
- Electric and pneumatic actuators

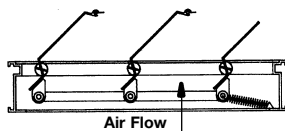

HORIZONTAL MOUNT – AIR FLOW UP
(Not available air flow down)

INSTALLATION

For proper operation, the damper must be installed square and free from racking.

The C460 is intended to be self supporting only in the largest single section size. Multiple section damper assemblies may require bracing to support the weight of the assembly and to hold against system pressure. Lau recommends appropriate bracing to support the damper horizontally at least once for every 8 feet of damper width. Vertical assemblies and higher system pressures may require more bracing.

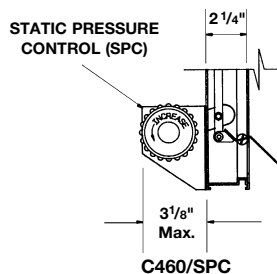

FEATURES

The C460 backdraft damper is ideally suited to heavy duty applications that demand less than 12 CFM per square foot of leakage at .5" w.g. When the C460 is equipped with the SPC (static pressure control) option, field adjustment can be made to maintain static pressures in the ranges up to .25" w.g. for dampers up to 17.3 sq. ft. and up to .75" w.g. for dampers up to 6 sq. ft. Aluminum construction helps maintain the damper's good-looking appearance and offers excellent resistance to corrosion. Contemporary styling features blades that overlap the frame for optimum weather resistance.

PERFORMANCE DATA

AMCA Standard 500 provides a reasonable basis for testing and rating dampers. Testing to AMCA 500 is performed under a certain set of laboratory conditions. This does not guarantee that other conditions will not occur in the actual environment where dampers must operate.

Design should provide a reasonable safety factor for damper performance by selecting at some point below damper leakage or pressure drop system requirements.

DAMPER PERFORMANCE

DAMPER WIDTH	MAXIMUM BACK PRESSURE	MAXIMUM SYSTEM VELOCITY	LEAKAGE % OF MAX. FLOW	LEAKAGE CFM/ SQ. FT.
48"	4" w.g.	2500 FPM	.6	15
36"	8" w.g.	2500 FPM	.6	15
24"	12" w.g.	2500 FPM	.7	17.5
12"	16" w.g.	2500 FPM	1.0	25

OPERATIONAL PRESSURES INCHES W.G.

BLADES START TO OPEN	BLADES FULLY OPEN
.12" w.g.	.20" w.g.

**Leakage information based on pressure differential of 1" w.g.

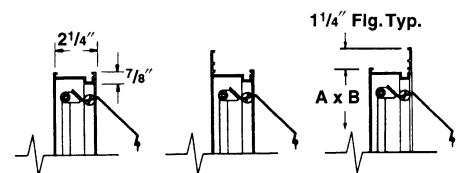

FRAME CONSTRUCTIONS



*Units furnished approximately 1/4" smaller than given opening dimensions.

BACKDRAFT DAMPERS



C412 Counter Balanced Aluminum, Light Duty

STANDARD CONSTRUCTION

(Spot velocities up to 1500 FPM)

FRAME

6063T5 extruded aluminum .090" wall thickness. Mitered corners.

BLADES

.025" formed aluminum with extruded vinyl edge seals.

BEARINGS

Synthetic.

LINKAGE

1/8" x 1/2" aluminum tie bars concealed in frame.

COUNTERBALANCE

Zinc plated steel weights on blades. Adjustable for final "on the job" setting.

FINISH

Mill.

MINIMUM SIZE

6"w x 7"h

MAXIMUM SIZE

Single section – 40"w x 48"h

Assembly of sections – size unlimited.

TEMPERATURE LIMITS

-40°F (-40°C) +200°F (93°C).

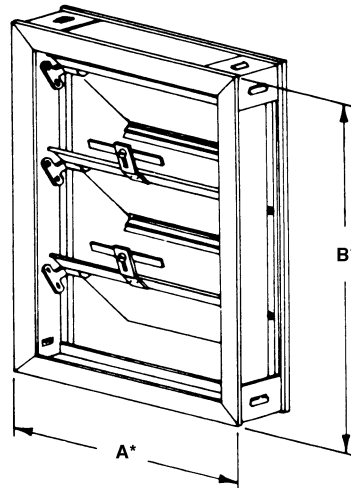

FEATURES

Extremely sensitive gravity operated backdraft damper. Counterbalance weights can be set to relieve air at pressure differentials less than .01 inches w.g.

Provides excellent weather protection when installed in exterior walls.



When used in fan discharge applications, damper should be located at least 1/2 fan diameter from fan discharge.

PERFORMANCE DATA

Damper Width	Maximum Back Pressure (External wind velocity)	Maximum System Velocity	Leakage*	
			% of Max. Flow	CFM/sq. ft.
40"	55 mph/1.5" w.g.	1000 FPM	1.5	15.0
36"	70 mph/2.5" w.g.	1000 FPM	1.5	15.0
24"	85 mph/3.5" w.g.	1000 FPM	2.0	20.0
12"	95 mph/4.5" w.g.	1000 FPM	4.0	40.0

*Leakage information based on pressure differential of 1" w.g.

INSTALLATION

Install with frame square without twisting or racking. Shims should be used between damper frame and opening or duct to prevent distortion of the frame. Multiple section assemblies must be fastened together on all sides, and top and bottom. Appropriate bracing must be supplied at every horizontal mullion and vertical bracing every 8' of damper width. Blade counter balance weights must be positioned to set desired blade opening pressure to complete installation.

When used in fan discharge applications, damper should be located at least 1/2 fan diameter from fan discharge. Isolation from excessive fan vibration is recommended.

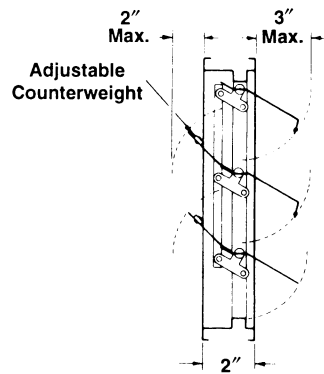

VERTICAL MOUNT

FRAME CONSTRUCTION

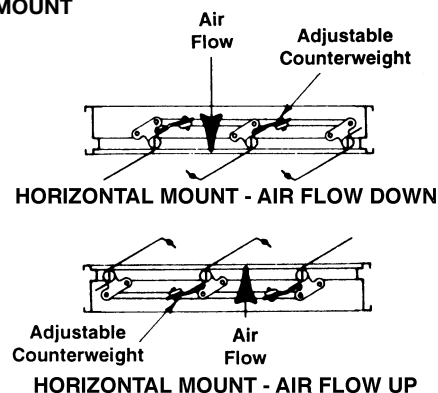
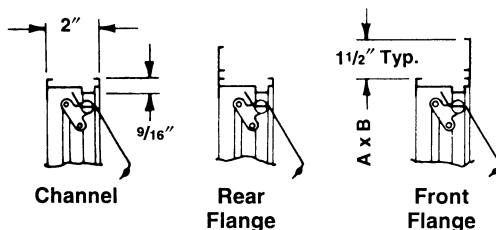

HORIZONTAL MOUNT - AIR FLOW DOWN

HORIZONTAL MOUNT - AIR FLOW UP



*Units furnished approximately 1/4" smaller than given opening dimensions.

Specifications are subject to change without notice or obligation

STANDARD CONSTRUCTION

FRAME

4" x 1" x 6063T5 extruded aluminum .081" nominal wall thickness.

BLADES

6063T5 extruded aluminum .070" nominal wall thickness.

AXLES

1/2" diameter synthetic.

BEARINGS

Dust proof ball bearings pressed into frame.

LINKAGE

1/8" x 1/2" aluminum tie bars with stainless steel pivot pins.

SEALS

Extruded vinyl locked into blade edge.

MOUNTING

Vertical – Air flow horizontal.

Horizontal – Air flow up or down.

MINIMUM SIZE

6" w x 11" h

MAXIMUM SIZE

Single section – 48" w x 52" h

Multiple section assembly – Unlimited size.

INSTALLATION

Install with frame square without twisting or racking. Shims should be used between damper frame and opening or duct to prevent distortion of the frame. Multiple section assemblies must be fastened together on all sides, and top and bottom. Appropriate bracing must be supplied at every horizontal mullion and vertical bracing every 8 feet of damper width. Blade counter balance weights must be positioned to set desired blade opening pressure to complete installation.

When used in fan discharge applications, damper should be located at least 1/2 fan diameter from fan discharge. Isolation from excessive fan vibration is recommended.

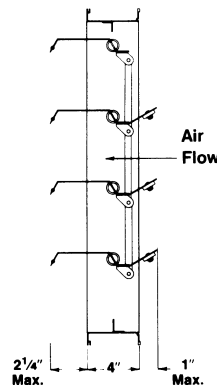
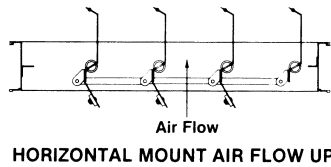
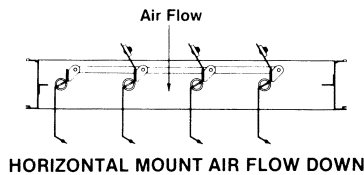
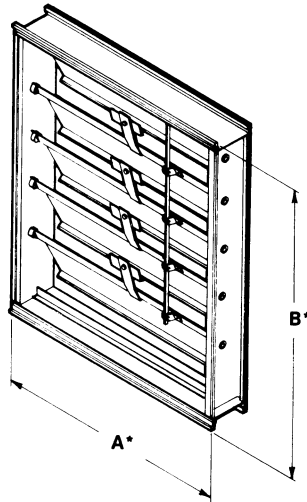

FEATURES

The C414 is designed for gravity relief at relatively low pressure differentials and low velocity airflow. Adjustable counterbalance weights enable the damper to operate in the range of .01 to .05 inches water gauge.

PERFORMANCE DATA

DAMPER WIDTH	MAXIMUM BACK PRESSURE	MAXIMUM SYSTEM VELOCITY	LEAKAGE*		BLADES START TO OPEN	BLADES FULLY OPEN
			Percent of Max. Flow	CFM/Sq. Ft.		
48"	4.0" w.g.	2500 FPM	.7%	17.5		
36"	8.0" w.g.	2500 FPM	.8%	20	.01" w.g.	.05" w.g.
24"	12.0" w.g.	2500 FPM	.9%	23		
12"	16.0" w.g.	2500 FPM	1.6%	40		

*Leakage information based on pressure differential of 1" w.g. tested per AMCA Std. 500.

DAMPER PRESSURE DROP

Damper Open (24" x 24" size)

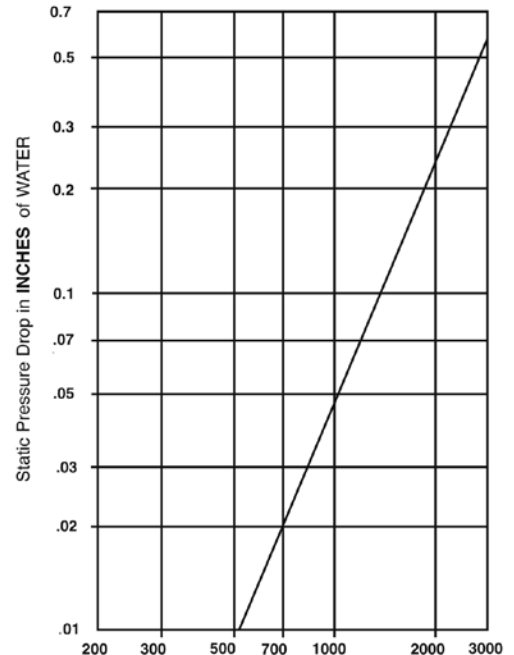

Air Velocity in FEET per minute through FACE AREA.

Tested per AMCA Std. 500, Fig. 5.3, duct work upstream and downstream.

FRAME CONSTRUCTIONS

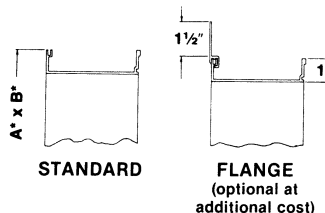

*Units furnished approximately 1/4" smaller than given opening dimensions.

BACKDRAFT DAMPERS



C416 Counter Balanced Aluminum, Heavy Duty

STANDARD CONSTRUCTION

FRAME

6063T5 extruded aluminum
.125" wall thickness.

BLADES

6063T5 extruded aluminum
.070" wall thickness with extruded vinyl edge seals.

BEARINGS

Zytel.

LINKAGE

1/8" x 1/2" aluminum tie bars.

COUNTERBALANCE

Zinc plated bar on blades (except top blade).
Adjustable for final "on the job" setting.

FINISH

Mill.

MINIMUM SIZE

6"w x 10"h

MAXIMUM SIZE

Single section – 48"w x 52"h
Assembly of sections – unlimited.

TEMPERATURE LIMITS

-40°F (-40°C) minimum and +200°F (93°C) maximum.

VARIATIONS (at extra charge)

- Special Finishes
- Flange Frames
 - Bird or Insect Screens



When used in fan discharge applications, damper should be located at least 1/2 fan diameter from fan discharge.

INSTALLATION

For proper operation, the damper must be installed square and free from racking.

The C416 is intended to be self supporting only in the largest single section size. Multiple section damper assemblies may require bracing to support the weight of the assembly and to hold against system pressure. Lau recommends appropriate bracing to support the weight of the assembly and to hold against system pressure. Lau recommends appropriate bracing to support the damper horizontally at least once for every 8' of damper width. Vertical assemblies and higher system pressures may require more bracing.

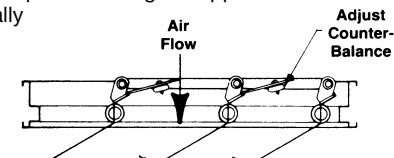

HORIZONTAL MOUNT — AIR FLOW DOWN

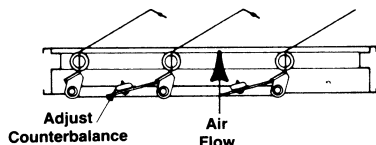

HORIZONTAL MOUNT — AIR FLOW UP

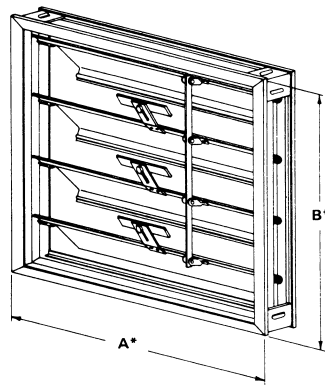

FRAME CONSTRUCTION

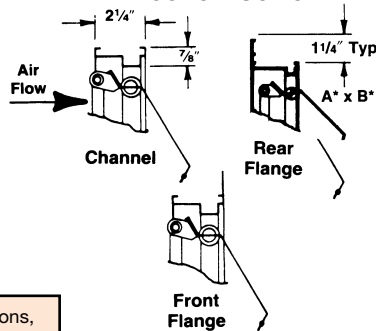

FEATURES

Weather resistant for relief air applications in exterior walls, this specially counter-balanced unit will relieve at extremely low pressures (approximately .02 inches w.g.). It is also of rugged design and Heavy Duty Construction allowing the handling of large air flows – Maximum spot velocities up to 3,500 FPM.

PERFORMANCE DATA

DAMPER WIDTH	MAXIMUM BACK PRESSURE	MAXIMUM SYSTEM VELOCITY	LEAKAGE*		BLADES START TO OPEN	BLADES FULLY OPEN
			Percent of Max. Flow	CFM/ Sq. Ft.		
48"	4.0" w.g.	2500 FPM	.6%	15		
36"	8.0" w.g.	2500 FPM	.6%	15	.01" w.g.	.05" w.g.
24"	12.0" w.g.	2500 FPM	.7%	17.5		
12"	16.0" w.g.	2500 FPM	1.0%	25		

*Leakage information based on pressure differential of 1" w.g. tested per AMCA Std. 500.

DAMPER PRESSURE DROP

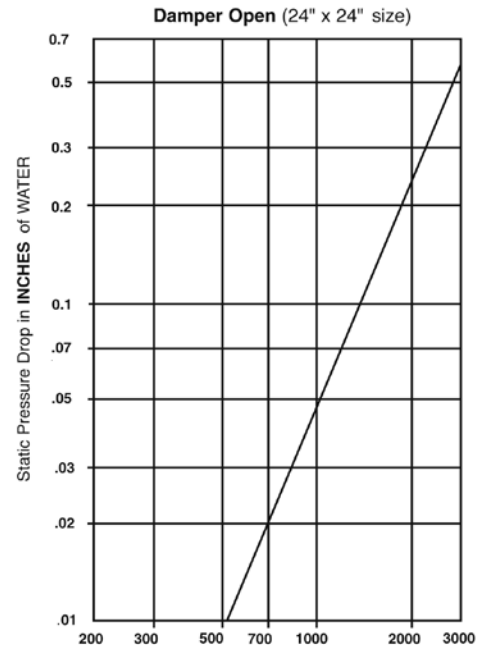

Air Velocity in FEET per minute through FACE AREA.
Tested per AMCA Std. 500, Fig. 5.3, duct work upstream and downstream.



*Units furnished approximately 1/4" smaller than given opening dimensions.

Specifications are subject to change without notice or obligation

CRBD2 Round

STANDARD CONSTRUCTION

FRAME

20 gauge galvanized steel up to 24" diameter, 11" long.

BLADES

.016" thick aluminum.

BLADE STOP AND AXLE KEEPER

20 gauge galvanized.

BLADE SEAL

Vinyl foam.

AXLES

3/16" dia. plated steel.

FINISH

Mill galvanized frame, mill finished blades.

DAMPER SIZES

(D Diameter) 6", 7", 8", 9", 10", 12", 14", 16", 18", 20", 22", 24".

MAX. VELOCITY

2000 FPM.

TEMPERATURE LIMITS

-40°F (-40°C) minimum and +150°F (165°C) maximum.

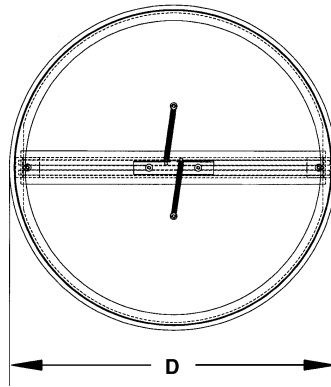

Air entering side

FEATURES

The CRBD2 was developed in response to industry requirements for a round backdraft damper with low leakage and easy to install in round spiral duct work. The specially designed blades with closing spring insure a tight seal to minimize back flow through the damper. Lau's exclusive blade hinge design has no frame penetrations to allow air leakage out of the duct. Integral rolled blade stop insures correct installation of blade seal and positioning of blades in the damper.

Damper can be used for vertical and horizontal air flow conditions.

STATIC PRESSURE	LEAKAGE IN CFM. PER SQUARE FOOT
1.0	8.7
1.5	11.0
2.0	10.6
2.5	11.6
3.0	13.0

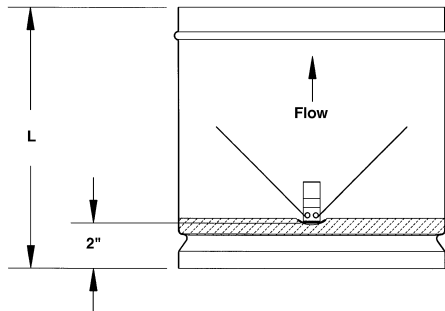

DIAMETER	"L"
6" through 9"	6"
Over 9" through 16"	10"
Over 16" through 24"	14"

Leakage for a 6" diameter unit at the following static pressure.

VELOCITY vs. PRESSURE DROP

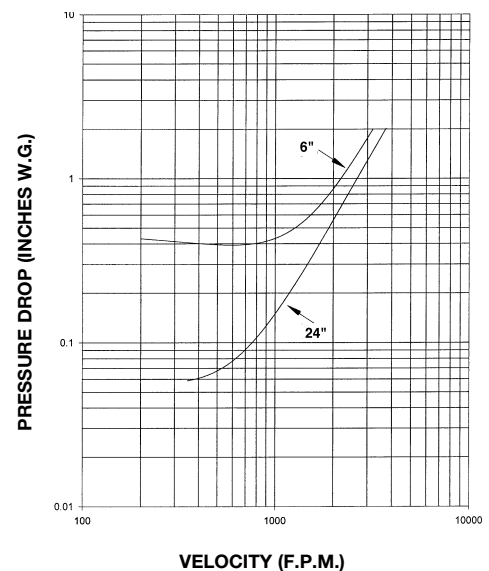

Pressure drop is for 6" and 24" diameter units.



*Units furnished approximately 1/4" smaller than given opening dimensions.

3

MINUTE QUOTE, DAY BUILD.

**For the fastest service on
your damper order, call
Lau Parts Division.**

*We will quote our job in 3 minutes or less
and offer a 3-day build with no upcharge
on the industry's most popular products.*

Static / Dynamic Fire Dampers

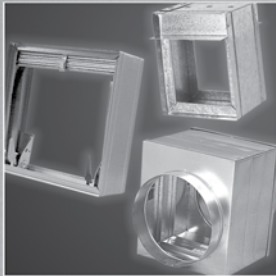

Ceiling Radiation Dampers



Control Dampers

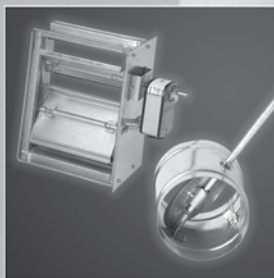

Backdraft Dampers

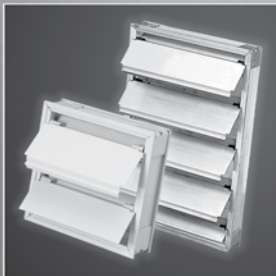

Louvers



Access Doors



Lau

CFS1 & CFS2 Fire & Smoke Damper Actuators Electric & Pneumatic – 250°F

ELECTRIC TWO POSITION ACTUATORS FOR UL555 TEMPERATURE RATINGS OF 250°F. (Actuators for CFS models not shown are on model price sheets)

Model	Voltage	Max. Damper Size (per actuator) at 4" w.g	
		CFS1	CFS2
H2000/3	120 AC	3 Ft. ² and 32"w and 32"h	3 Ft. ² and 36"w and 32"h
H2000/6	120 AC	6 Ft. ² and 32"w and 32"h	6 Ft. ² and 36"w and 32"h
H2000/8	120 AC	7.1 Ft. ² and 32"w and 32"h	8 Ft. ² and 36"w and 32"h
MS4209	120 AC	8 Ft. ² and 64"w and 36"h	8 Ft. ² and 72"w and 36"h
FSNF120	120 AC	8 Ft. ² and 64"w and 36"h	8 Ft. ² and 72"w and 36"h
FSNF 120S w/2 aux switches	120 AC	8 Ft. ² and 64"w and 36"h	8 Ft. ² and 72"w and 36"h
GGD221	120 AC	10.7 Ft. ² and 32"w and 48"h	12 Ft. ² and 36"w and 48"h
MS4120	120 AC	32"w and 48"h or 64"w and 32"h	36"w and 48"h or 72"w and 32"h
MS4120S w/2 aux switches	120 AC	32"w and 48"h or 64"w and 32"h	36"w and 48"h or 72"w and 32"h
FSAF120	120 AC	10.7 Ft. ² and 32"w and 48"h	12 Ft. ² and 36"w and 48"h
FASF120S w/2 aux switches	120 AC	10.7 Ft. ² and 32"w and 48"h	12 Ft. ² and 36"w and 48"h
H2024/3	24 AC	3 Ft. ² and 32"w and 32"h	3 Ft. ² and 36"w and 32"h
H2024/6	24 AC	6 Ft. ² and 32"w and 32"h	6 Ft. ² and 36"w and 32"h
H2024/8	24 AC	7.1 Ft. ² and 32"w and 32"h	8 Ft. ² and 36"w and 32"h
MS8209	24 AC	8 Ft. ² and 64"w and 36"h	8 Ft. ² and 72"w and 36"h
FSNF24	24 AC	8 Ft. ² and 64"w and 36"h	8 Ft. ² and 72"w and 36"h
FSNF24S w/2 aux switches	24 AC	8 Ft. ² and 64"w and 36"h	8 Ft. ² and 72"w and 36"h
MS8120	24 AC	32"w and 48"h or 64"w and 32"h	36"w and 48"h or 72"w and 32"h
MS8120S w/2 aux switches	24 AC	32"w and 48"h or 64"w and 32"h	36"w and 48"h or 72"w and 32"h
FSAF24	24 AC/DC	10.7 Ft. ² and 32"w and 48"h	12 Ft. ² and 36"w and 48"h
FSAF24S w/2 aux switches	24 AC/DC	10.7 Ft. ² and 32"w and 48"h	12 Ft. ² and 36"w and 48"h
H2230/3	230 AC	3 Ft. ² and 32"w and 32"h	3 Ft. ² and 36"w and 32"h
H2230/6	230 AC	6 Ft. ² and 32"w and 32"h	6 Ft. ² and 36"w and 32"h
H2230/8	230 AC	7.1 Ft. ² and 32"w and 32"h	8 Ft. ² and 36"w and 32"h
FSNF230	230 AC	8 Ft. ² and 64"w and 36"h	8 Ft. ² and 64"w and 36"h
FSNF230S w/2 aux switches	230 AC	8 Ft. ² and 64"w and 36"h	8 Ft. ² and 64"w and 36"h
MS4709	230 AC	8 Ft. ² and 64"w and 36"h	8 Ft. ² and 72"w and 36"h
MS4620	230 AC	32"w and 48"h	36"w and 48"h
MS4620S w/2 aux switches	230 AC	32"w and 48"h	36"w and 48"h

IMPORTANT NOTES:

1. Out of air stream mounting requires a sleeve or side plate.
2. Specify fail close position on all orders.
3. Lau recommends all actuators be mounted out of the air stream. Consult Lau if in air stream mounting is required.
4. Factory installed actuators out of the air stream may extend above or below the height of the damper. Consult Lau if specific clearances are required.

Specifications are subject to change without notice or obligation

CFS1 & CFS2 Fire & Smoke Damper Actuators 350°F – Electric & Pneumatic

ELECTRIC TWO POSITION ACTUATORS FOR UL555S TEMPERATURE RATINGS OF 350°F. (Actuators for CFS models not shown are on model price sheets)

Model	Voltage	Max. Damper Size (per actuator) at 4" w.g	
		CFS1	CFS2
ML4202	120 AC	1 Ft. ² and 24"w and 18"h	1 Ft. ² and 28"w and 24"h
FSLF120	120 AC	24"w and 24"h	24"w and 24"h
FSLF120S w/2 aux switches	120 AC	24"w and 24"h	24"w and 24"h
MS4209	120 AC	8 Ft. ² and 64"w and 36"h	8 Ft. ² and 72"w and 36"h
FSNF120	120 AC	8 Ft. ² and 64"w and 36"h	8 Ft. ² and 72"w and 36"h
FSNF120S w/2 aux switches	120 AC	8 Ft. ² and 64"w and 36"h	8 Ft. ² and 72"w and 36"h
MS4120	120 AC	32"w and 48"h	36"w and 48"h
MS4120S w/2 aux switches	120 AC	32"w and 48"h	36"w and 48"h
ML8202	24 AC	1 Ft. ² and 24"w and 18"h	1 Ft. ² and 28"w and 24"h
FSLF24	24 AC	24"w and 24"h	24"w and 24"h
FSLF24S w/2 aux switches	24 AC	24"w and 24"h	24"w and 24"h
MS8209	24 AC	8 Ft. ² and 64"w and 36"h	8 Ft. ² and 72"w and 36"h
FSNF24	24 AC	8 Ft. ² and 64"w and 36"h	8 Ft. ² and 72"w and 36"h
FSNF24S w/2 aux switches	24 AC	8 Ft. ² and 64"w and 36"h	8 Ft. ² and 72"w and 36"h
MS8120	24 AC	32"w and 48"h	36"w and 48"h
MS8120S w/2 aux switches	24 AC	32"w and 48"h	36"w and 48"h
FSNF230	230 AC	8 Ft. ² and 64"w and 36"h	8 Ft. ² and 64"w and 36"h
FSNF230S w/2 aux switches	230 AC	8 Ft. ² and 64"w and 36"h	8 Ft. ² and 64"w and 36"h
MS4709	230 AC	8 Ft. ² and 64"w and 36"h	8 Ft. ² and 72"w and 36"h
MS4620	230 AC	32"w and 48"h	36"w and 48"h
MS4620S w/2 aux switches	230 AC	32"w and 48"h	36"w and 48"h

PNEUMATIC TWO POSITION ACTUATORS FOR UL555S TEMPERATURE RATINGS OF 250°F. (Actuators for CFS models not shown are on model price sheets)

Model	Air Pressure Minimum	Max. Damper Size (per actuator) at 4" w.g	
		CFS1	CFS2
331-4827	25 psi	4 Ft. ² and 24"w and 24"h	4 Ft. ² and 24"w and 24"h
331-2961	25 psi	10.7 Ft. ² and 32"w and 48"h	12 Ft. ² and 36"w and 48"h
331-3060	25 psi	64"w and 48"h	72"w and 48"h

PNEUMATIC TWO POSITION ACTUATORS FOR UL555S TEMPERATURE RATINGS OF 350°F. (Actuators for CFS models not shown are on model price sheets)

Model	Air Pressure Minimum	Max. Damper Size (per actuator) at 4" w.g	
		CFS1	CFS2
331-4827	25 psi	4 Ft. ² and 24"w and 24"h	4 Ft. ² and 24"w and 24"h
331-3060	25 psi	10.7 Ft. ² and 32"w and 48"h	12 Ft. ² and 36"w and 48"h

Specifications are subject to change without notice or obligation

REPLACEMENT FUSE LINKS Style A, Style B, Style J

FUSE LINK – STYLE A

Specify 165°F, 212°F or 285°F
for all CP and CPD Curtain Type Fire Damper
Models excluding CPT

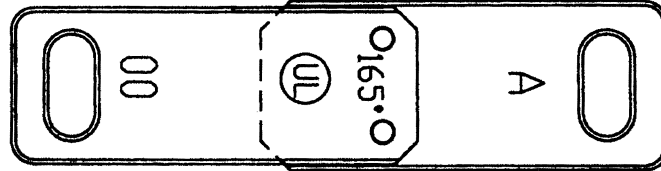

Discontinued Fuse Links – Replace with Style A

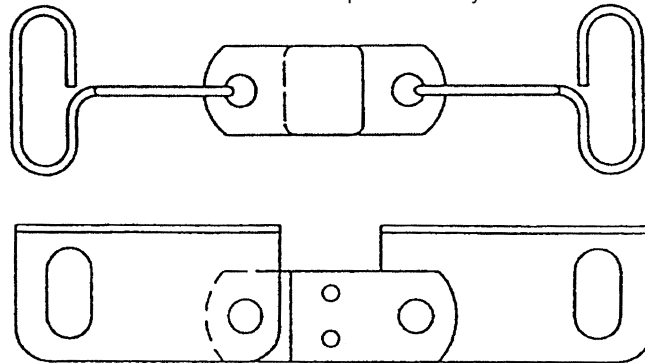

FUSE LINK – STYLE B & STYLE J

Specify 165°F, 212°F or 285°F

STYLE B
CPD35, CPT Dampers

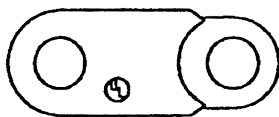

STYLE J
All CCD's, all PFL's

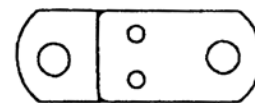

INTEGRAL SLEEVES & RETAINING ANGLES FAST and PFMA

FAST AND PFMA

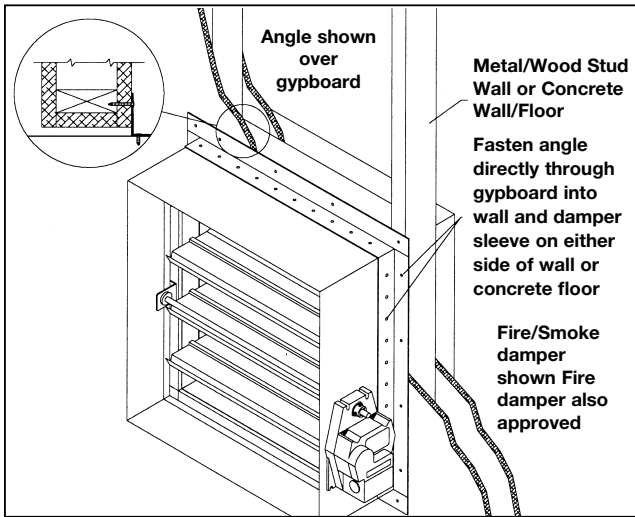

Figure 1
FAST ANGLE

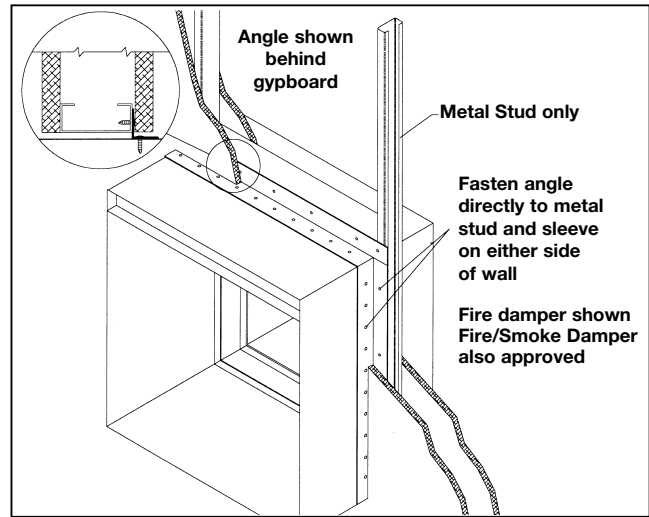

Figure 2
FAST ANGLE

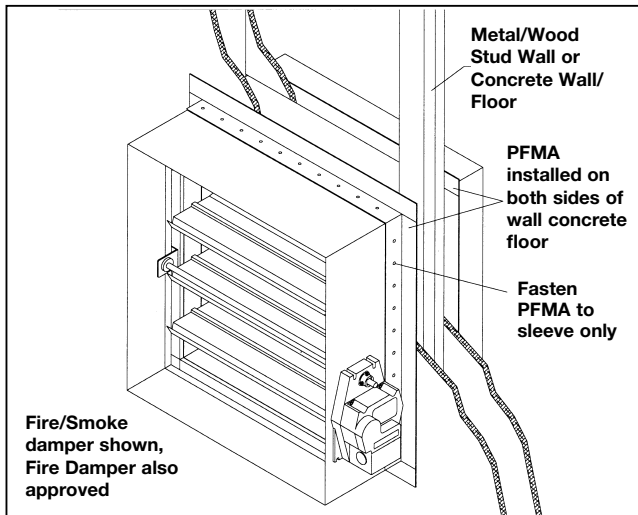

Figure 3
PFMA

APPLICATION – WALLS AND CONCRETE FLOORS

Lau FAST and PFMA are 20 gauge steel mounting angles designed and approved for use specifically with Lau fire and fire/smoke dampers. Unlike conventional mounting angles that cannot be fastened together in the corners and ship separately from the dampers, the FAST and PFMA are:

- One piece angles (fastened together in the corners)
- Shipped loose around damper
- Provided with pre-punched sleeve fastener holes on 2" centers.

The Lau FAST and PFMA make fire and fire/smoke damper installation easier and less costly.

FAST – ONE SIDE ANGLE (Figure 1 & Figure 2)

The Lau FAST angle is designed and UL approved for use with Lau 1½ hour rated fire and combination fire/smoke dampers. An angle on "one side" is approved for opening sizes 90" w x 48" h or 48" w x 90" h in metal stud, wood stud walls or concrete/masonry walls and floors.

For one side angle installations the FAST must be fastened to the damper sleeve and partition in accordance with the damper basic installation instructions. Both FAST and PFMA angles require factory installed sleeve.

PFMA – TWO SIDE ANGLES (Figure 3)

The Lau PFMA is designed and UL approved for use with Lau 1½ or 3 hour fire and fire/smoke dampers when two angle installations are required or desired. PFMA are installed on both sides of the partition and fastened only to the damper sleeve in accordance with the damper basic installation instructions.



DSDF Flow Duct Smoke Detector

DEFINITION

The DSDF is designed for use with Lau UL Classified Smoke and Fire/Smoke Dampers. The device detects the presence of smoke in the airstream of ductwork in HVAC systems operating at no less than 300 fpm.

DSDF (flow rated duct smoke detectors) are factory mounted for "single point field power connection" to a standard Lau electronic fuse link (EFL) or optional FireStat (TS150).

The DSDF factory mounted with a smoke rated damper is intended to close the damper only. The DSDF can be field wired back to a UL listed fire alarm panel by others.

APPROVAL

Underwriter's Laboratories, Inc. does not have a separate Product Category for factory mounted smoke detectors. The smoke detector and the damper have been individually evaluated by their applicable UL standards.

Since the smoke detector is not rated for use at velocities below 300 fpm, local code may require an alternative means of damper closure such as zone detection or automated damper closure when the system fan is shut down. The local authority having jurisdiction should be consulted prior to installation of the damper and smoke detector.

APPLICATION

National and local safety standards and codes recognize the ability of air duct systems to transfer smoke, toxic gases and flame from area to area. Smoke can be a serious hazard to life safety unless blowers are shut down and dampers are actuated. **The primary purpose of duct smoke detection is to prevent injury, panic and property damage by reducing the spread of smoke.** Duct smoke detection can also serve to protect the air conditioning system itself from fire and smoke damage, and can be used to assist in equipment protection applications. Duct smoke detectors can be supplied by Lau in one of two ways:

1. Factory mounted for single point field wiring connection.
2. Shipped loose for field installation.

If the detector is shipped loose for field installation refer to the duct smoke detector manufacturer's installation instructions (shipped with each detector) for proper application.

When presence of smoke in the duct is sensed, or when loss of power occurs the damper will fail close. **Consult NFPA90A, NFPA72 documents and local codes to determine where smoke detectors are required.**

DAMPERS

The DSDF can be factory mounted on any of the following Lau combination fire/smoke and smoke dampers: CFS1, CFS2, CSD37 and CSD36.

ACCESSORIES

Annunciators, remote test and reset stations, sounders, strobes, etc. are available from the duct smoke detector manufacturer.

Model DSDF Flow Smoke Detectors meets the requirements established by:

- **CSFM California State Fire Marshal** (consult Lau for complete list of CSFM listed products) UL Listing (S1383)



SEE COMPLETE MARKING ON PRODUCT

MAINTENANCE AND SERVICE OF DUCT DETECTORS

Dust, dirt and other foreign matter can accumulate inside a detector and change its sensitivity. Detectors should be tested and maintained periodically. Routine maintenance should be performed at least once a year and more frequently in dirtier environments. Refer to NFPA90A, NFPA72 and detector manufacturer's instructions packaged with each detector for specific maintenance and testing information.

DSDF DESCRIPTION/SPECIFICATION

Model: Hochiki DH-98

Type: Photoelectronic (Consult Lau for availability of Ionization type detectors).

Velocity: 300 to 4,000 fpm.

Dimensions (L x W x D): 9 1/8" x 7 1/4" x 2 1/4".

Weight: 3 lbs.

Operating Temperature Range: 32°F to 120°F.

Operating Humidity Range: 10% to 85% Relative Humidity.

Operating Voltages: 24 VAC/VDC or 120/220 VAC operation.

Contact Ratings: Refer to information provided with detector.

Alarm Reset: Push button on DSDF unit (not remote reset).

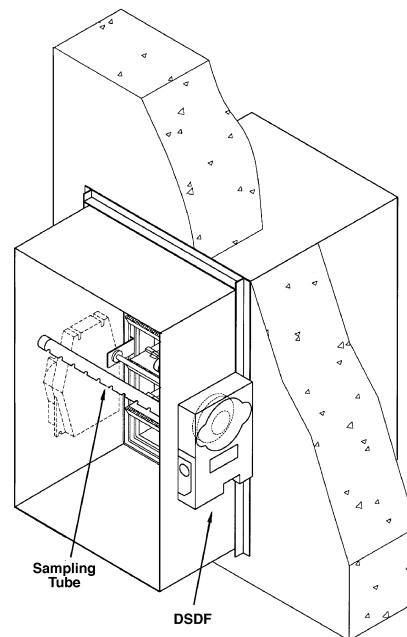

Specifications are subject to change without notice or obligation

DSDF Flow Duct Smoke Detector

FACTORY MOUNTING DETAILS

The DSD is mounted on the opposite side of the sleeve from the actuator.

 Lau factory installs the duct smoke detector with holes in sampling tube pointed away from the damper. The sampling tube must be rotated in the field so the holes are pointed in the direction of the air flow. Minimum damper size is 5" wide x 6" high (actual size).

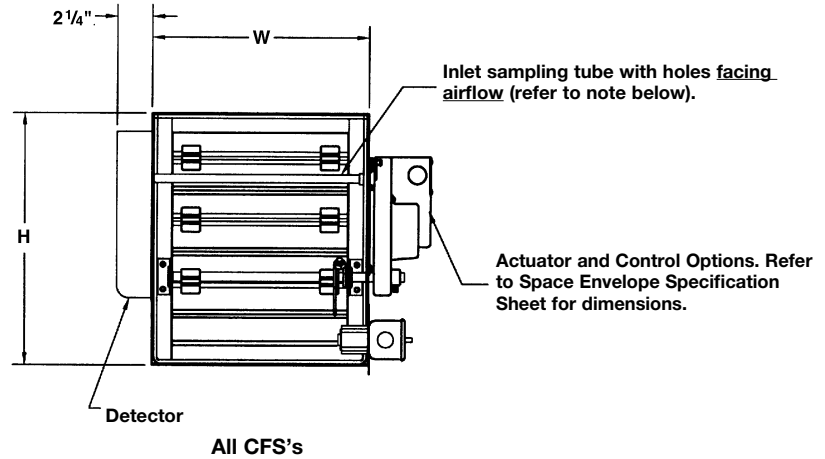

DSD FACTORY WIRED TO CFS WITH EFL

 1. Not all screw terminals \emptyset in the DSD compartment are shown, for clarity.
2. Connectors between screw terminals 6, 7 & 8 are pre-wired by the DSD manufacturer. At smoke condition, contact between 6 & 7 breaks: contact between 7 and 8 makes.
3. Switch "S" by others.
4. These wiring diagrams apply to model DH-98 duct smoke detector (made by HOCHIKI) with either photoelectric or ionization detector head.
5. // Indicated connections needed to be made in the field by qualified electrician.

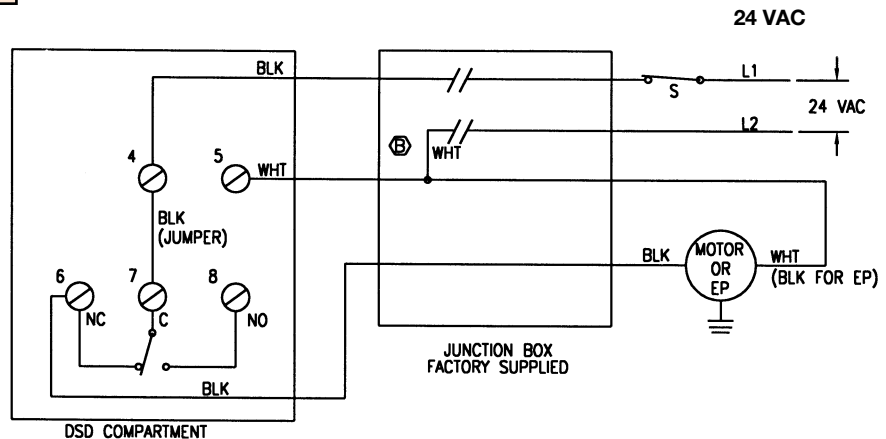
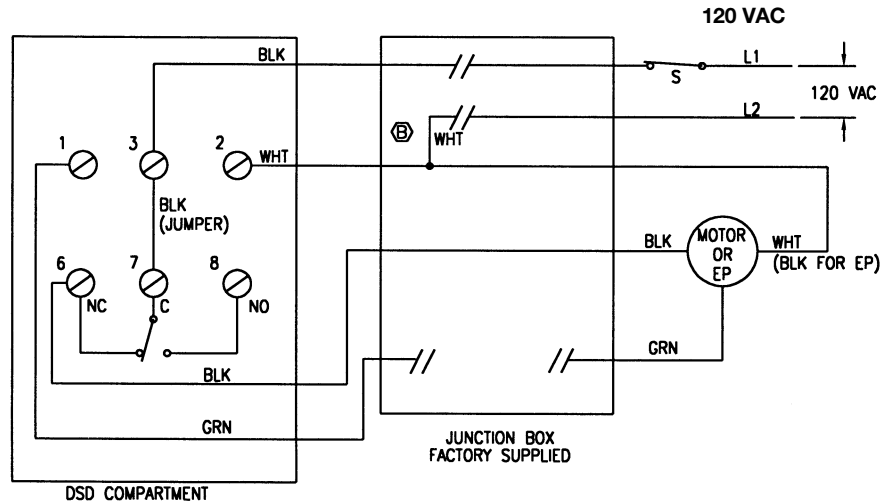

Specifications are subject to change without notice or obligation

DSDF Flow Duct Smoke Detector

DSD FACTORY WIRED TO CFS WITH EFL/SP100

120 VAC

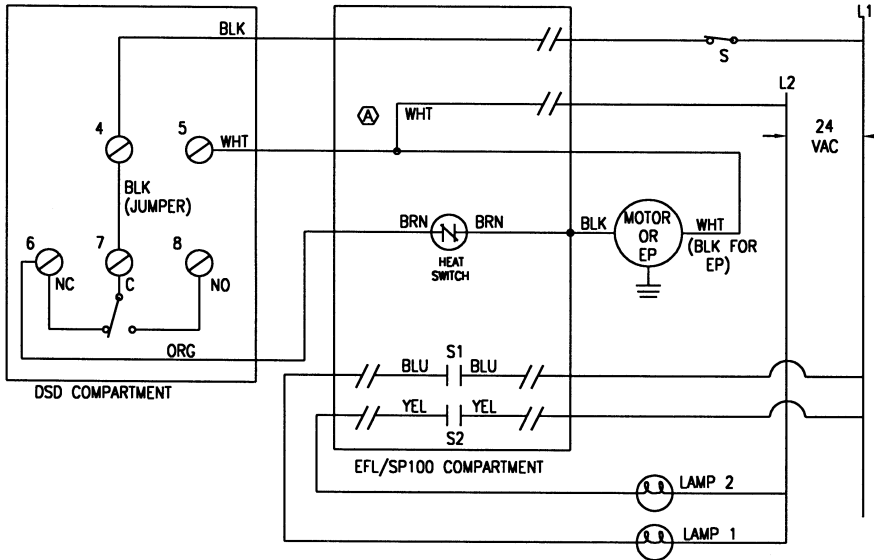

24 VAC

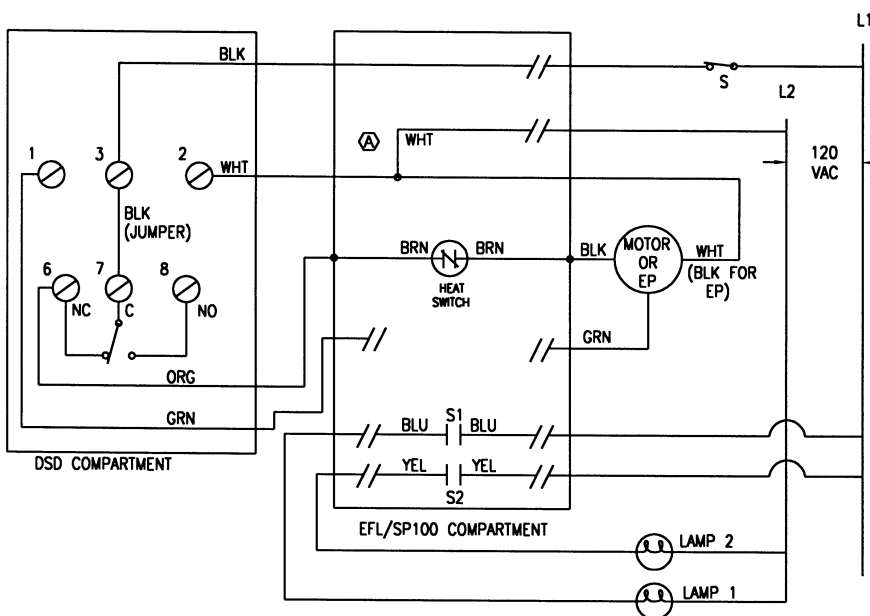

1. Not all screw terminals \emptyset in the DSD compartment are shown, for clarity.

2. Connectors between screw terminals 6, 7 and 8 are pre-wired by the DSD manufacturer. At smoke condition, contact between 6 and 7 breaks: contact between 7 and 8 makes.

3. Switch "S" lamp 1 and lamp 2 are by others.

4. These wiring diagrams apply to model DH-98 duct smoke detector (made by HOCHIKI) with either photoelectric or ionization detector head.

5. // Indicated connections needed to be made in the field by qualified electrician.

DSDF Flow Duct Smoke Detector

DSD FACTORY WIRED TO FSD WITH TS-150

120 VAC

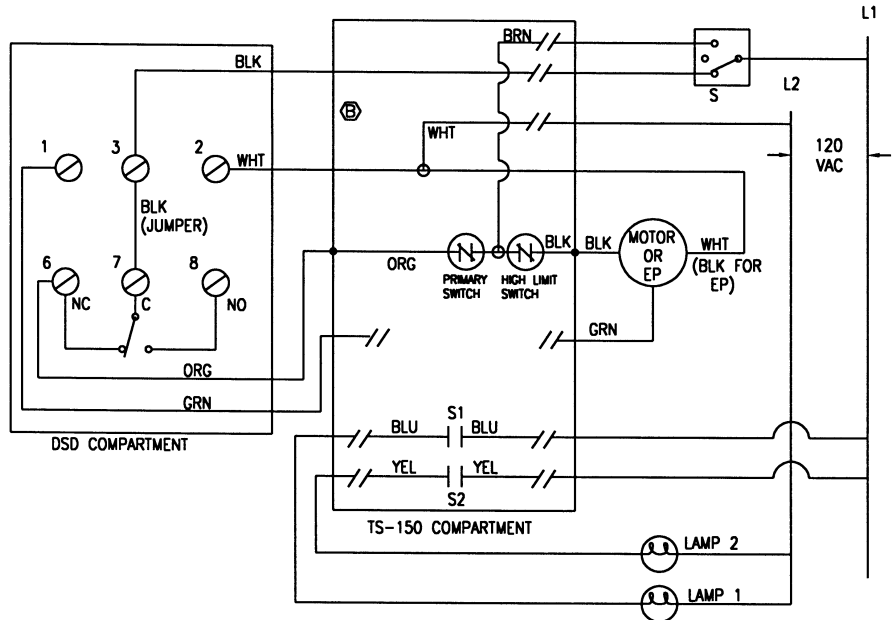

1. Not all screw terminals ø in the DSD compartment are shown, for clarity.

2. Connectors between screw terminals 6, 7 and 8 are pre-wired by the DSD manufacturer. At smoke condition, contact between 6 and 7 breaks: contact between 7 and 8 makes.
3. Switch "S" lamp 1 and lamp 2 are by others.
4. These wiring diagrams apply to model DH-98 duct smoke detector (made by HOCHIKI) with either photoelectric or ionization detector head.
5. // Indicated connections needed to be made in the field by qualified electrician.

24 VAC

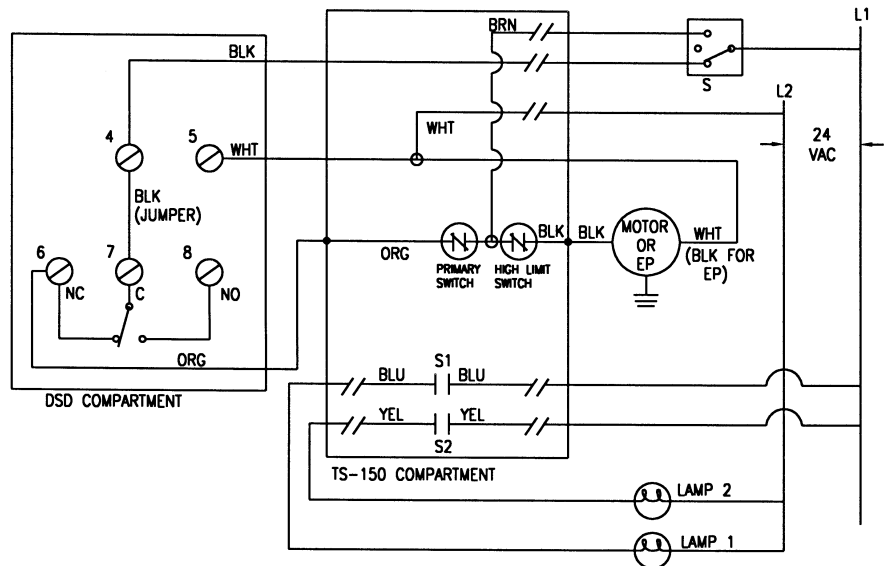

DSDN No Flow Duct Smoke Detector

DEFINITION

The DSDN (No Flow Duct Smoke Detector) is designed for use with Lau UL555S classified smoke dampers. The device detects the presence of smoke in the airstream of duct work in HVAC systems without a minimum operating velocity.

DSDN are factory mounted for "single point field power connection" to a standard Lau electronic fuse link (EFL) or optional FireStat (TS150).

The DSDN factory mounted with a smoke rated damper is intended to close the damper only. Consult Lau prior to ordering if DSDN is to be wired back to a UL listed fire alarm panel.

APPROVAL

Underwriter's Laboratories, Inc. does not have a separate Product Category for factory mounted smoke detectors. The smoke detector and the damper have been individually evaluated by their applicable UL standards.

The local authority having jurisdiction should be consulted prior to installation of the damper and smoke detector.

APPLICATION

National and local safety standards and codes recognize the ability of air duct systems to transfer smoke, toxic gases and flame from area to area. Smoke can be a serious hazard to life safety unless blowers are shut down and dampers are actuated. **The primary purpose of duct smoke detection is to prevent injury, panic and property damage by reducing the spread of smoke.** Duct smoke detection can also serve to protect the air conditioning system itself from fire and smoke damage, and can be used to assist in equipment protection applications.

When presence of smoke in the duct is sensed, or when loss of power occurs the damper will fail close. **Consult NFPA90A, NFPA72 documents and local codes to determine where smoke detectors are required.**

DAMPERS

The DSDN can be factory mounted on any of the following Lau combination fire/smoke and smoke dampers: CFS1, CFS2, CSD37 and CSD36.

ACCESSORIES

Annunciators, remote test and reset stations, sounders, strobes, etc. are available from the duct smoke detector manufacturer.

MAINTENANCE AND SERVICE OF DUCT DETECTORS

Dust, dirt and other foreign matter can accumulate inside a detector and change its sensitivity. Detectors should be tested and maintained periodically. Routine maintenance should be performed at least once a year and more frequently in dirtier environments. Refer to NFPA90A, NFPA72 and detector manufacturer's instructions packaged with each detector for specific maintenance and testing information.

Model DSDN No Flow Smoke Detectors meets the requirements established by:

- **CSFM California State Fire Marshal** (consult Lau for complete list of CSFM listed products)
- **Factory Mutual** approved #OX5A4.AY



DSDN DESCRIPTION/SPECIFICATION

Model: System Sensor 2151

Type: Photoelectric.

Velocity: 0 to 3,000 fpm.

Dimensions (Dia.): 6.1"

Weight: 3.6 oz.

Operating Temperature Range: 32°F to 120°F.

Operating Humidity Range: 10% to 93% Relative Humidity.

Operating Voltages: 120 VAC operation.

Contact Ratings: Refer to information provided with detector.

Latching Alarm: Reset by momentary power interruption (not automatic).

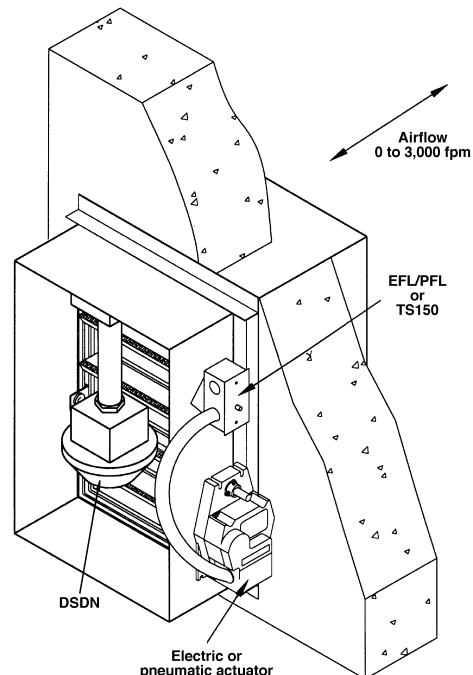

DSDN No Flow Duct Smoke Detector

FACTORY MOUNTING DETAILS

Minimum Size (see Note 1) – 8" w x 8" h

Maximum Size (see Note 2) – 36" w x 36" h

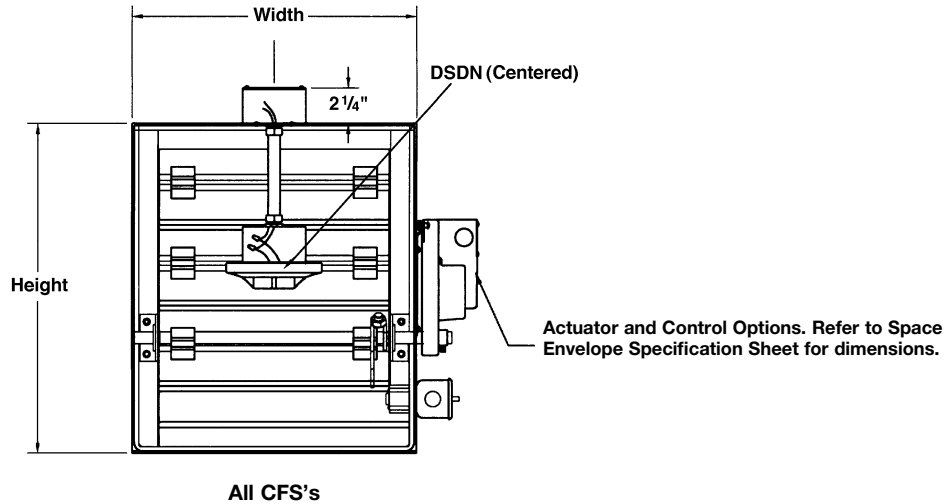

TYPICAL INSTALLATION DETAILS FOR FSD WITH DSDN

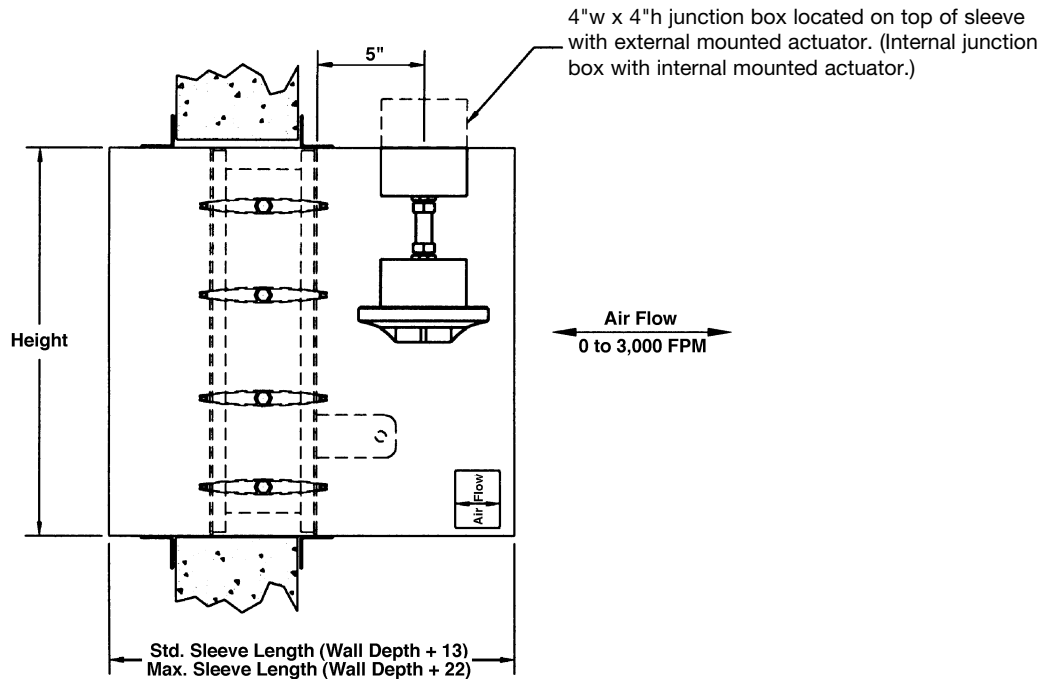

1. Consult Lau for minimum size for actuator in airstream.
2. Multiple detectors required for dampers larger than 36" w x 36" h. Consult Lau.

Specifications are subject to change without notice or obligation

DSDN No Flow Duct Smoke Detector

WIRING DIAGRAMS 120 VAC

DSD FACTORY WIRED TO CFS WITH EFL

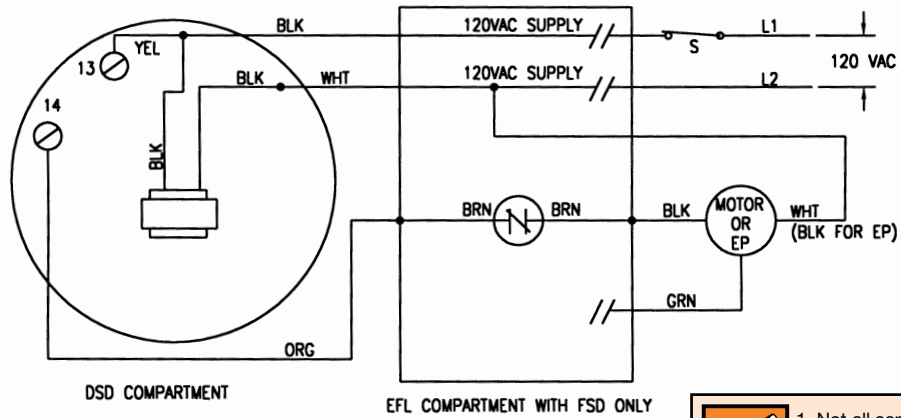

1. Not all screw terminals Ø in the DSD compartment are shown, for clarity.
2. Switch "S" by others.
3. These wiring diagrams apply to model B114LP duct smoke detector (made by System Sensor) with either photoelectric or ionization detector head.
4. // Indicated connections needed to be made in the field by qualified electrician.

DSD FACTORY WIRED TO CFS WITH EFL/SP100

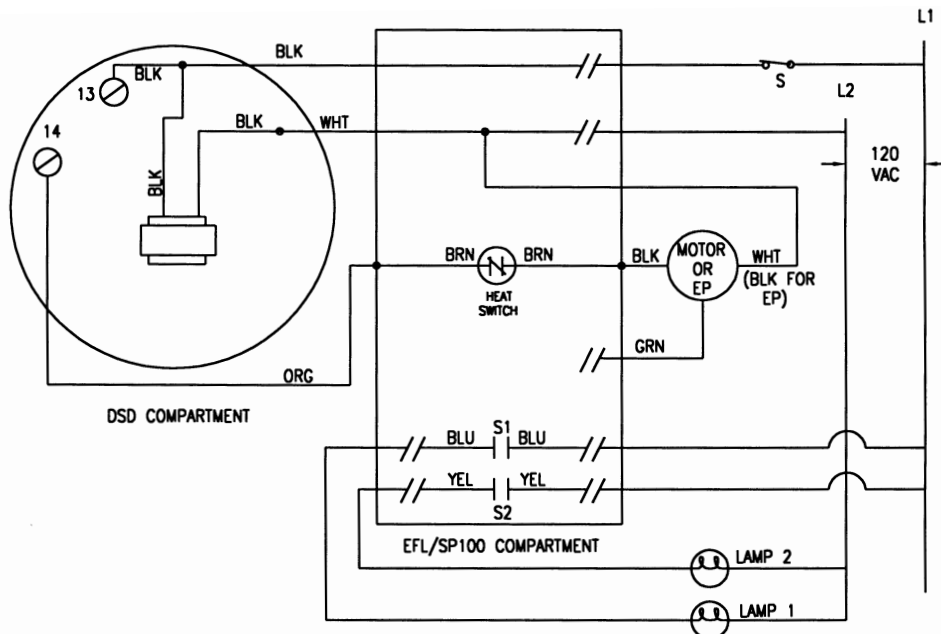

Specifications are subject to change without notice or obligation

DSDN No Flow Duct Smoke Detector

WIRING DIAGRAMS 120 VAC

DSDN FACTORY WIRED TO CFS WITH TS150

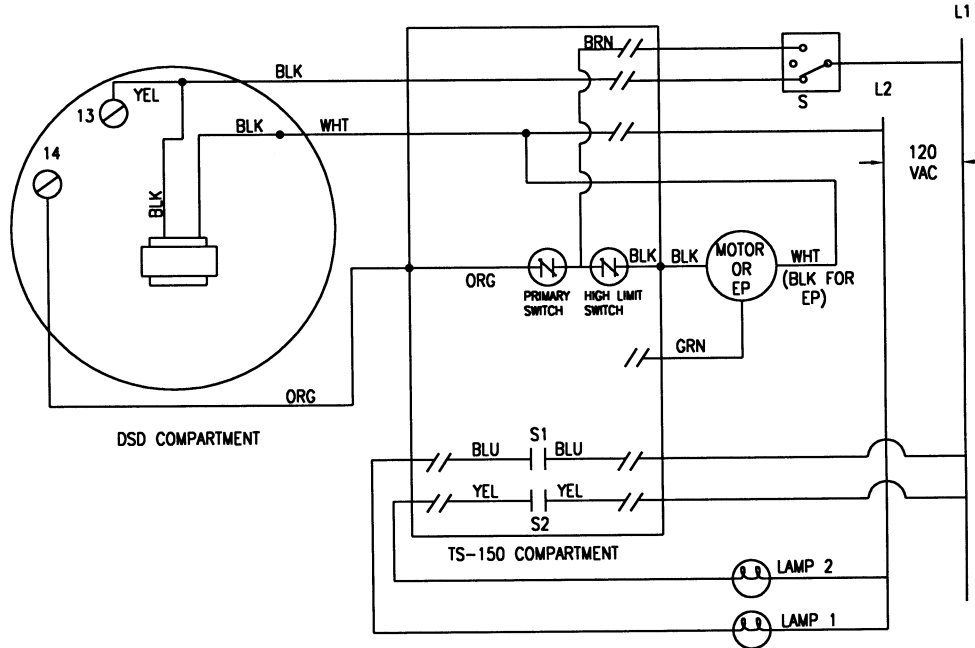

DSDN FACTORY WIRED TO SMOKE DAMPER

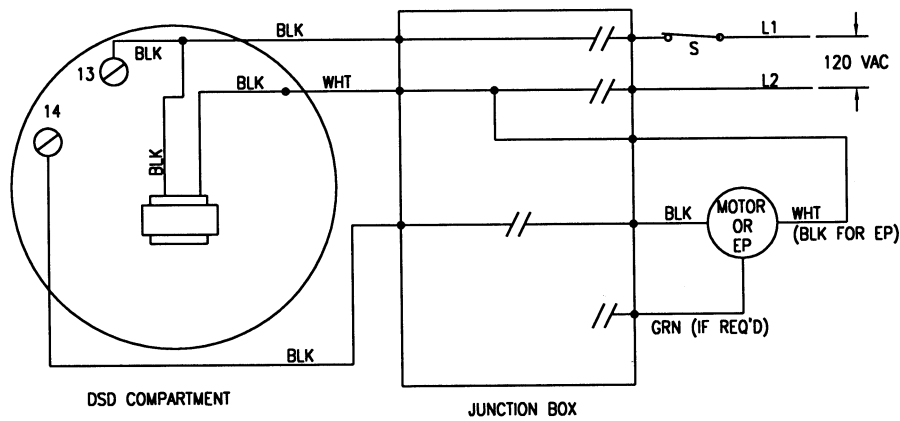

Specifications are subject to change without notice or obligation

TS150 FIRESTAT For "Re-Openable" Fire & Smoke Dampers

APPLICATION

The TS150 is a UL Classified heat responsive device which is used in conjunction with Lau fire/smoke dampers. The TS150 is an **optional** device which can be ordered with electric actuators or pneumatic actuators and EP (electro/pneumatic) switches. The TS150 allows the dampers to be reopened after the initial closure for dynamic smoke control. **The TS150 must be installed at the factory and cannot be added in the field. Replacement TS150's may be field installed with the approval of the local authority.**

SMOKE DETECTION/TEST/POWER FAILURE OPERATION

If smoke is detected, or during testing, or if power failure occurs, the damper will close and lock. When the smoke signal ceases (or smoke detector resets), the test is complete or power is restored the SYSTEM will automatically REMOTE RESET the damper to the open position. The damper automatically resets if nuisance alarms occur and the SYSTEM is reset. The damper may be closed at any time by placing the MCP1 (optional) or other control switch (by others) in the CLOSED position.

FIRE OPERATION

When the switch of a control panel (MCP) is in the NORMAL position and temperatures in excess of 165°F (212°F optional) are detected, the damper will close and lock and the damper CLOSED indicator light on the control panel will light.

The damper remains closed until the override signal for smoke management from a remote command station is present and the duct temperature has not exceeded the high limit. The high limit temperature sensor prevents the damper from reopening when duct temperature is above the damper's UL555S degradation test temperature of 250°F or 350°F. Upon cessation of the fire condition, the damper can be reopened by pressing the RESET button on the TS150 assembly. At no time will the damper disengage from the actuator. The integral SP100 will positively communicate to the fire commander via the control panel the position of the damper for smoke management purposes.

Refer to the appropriate damper installation instructions for details on damper installation. All electrical wiring and connections to the FireStat must be in accordance with the standards of the authorities having jurisdiction.

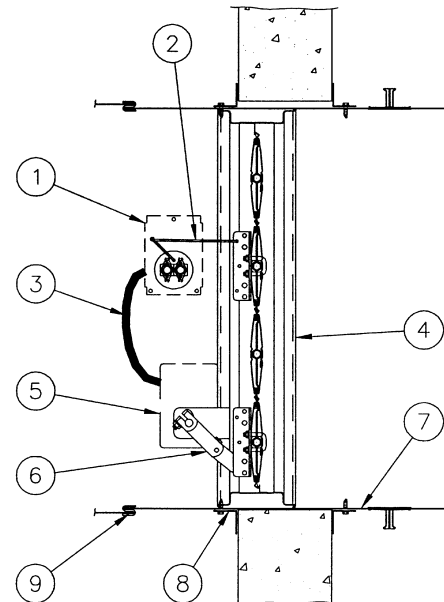

ITEM

1. TS150 Fire Stat
2. Adjustable Connecting Rod
3. Flex Conduit
4. Damper Frame
5. Actuator or EP Switch

ITEM

6. Over-Center Lock
7. Damper Sleeve
8. FAST, PFMA or conventional mounting angles
9. Sleeve to Duct Connection (by others)

S1 and S2 Switch AMP Ratings: 15 AMPS @ 24, 125 or 250 VAC
1/2 AMP @ 125 VDC, 1/4 AMP @ 250 VDC

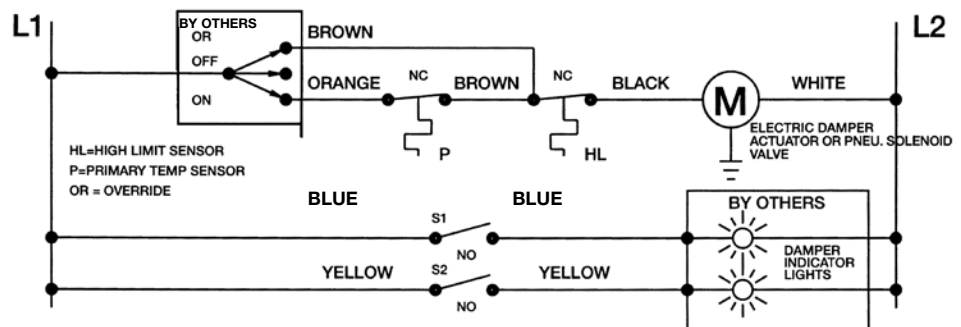
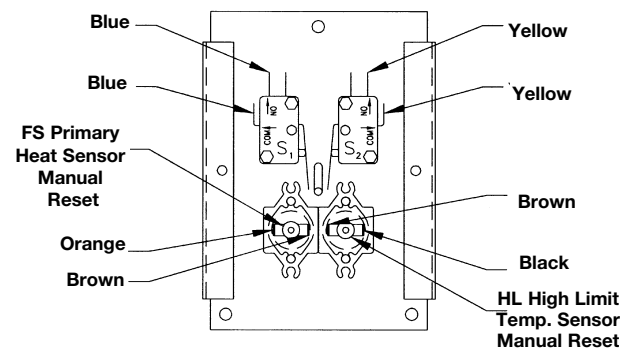

Specifications are subject to change without notice or obligation

MCP CONTROL PANELS MCP1, MCP14, MCP2 & MCP24

APPLICATION

The MCP1/14 and MCP2/24, are shipped as loose single control panels for use with in dynamic smoke management systems on fire/smoke dampers equipped with the TS150.

FEATURES

The MCP1/14 utilizes a toggle type switch and the MCP2/24 utilizes a "removable" key type switch. These control panels also have a "replaceable" red light for closed damper and a "replaceable" green light for open damper. The MCP1 and 2 are for use in 120VAC systems while the MCP14 and 24 are for use in 24VAC systems.

The toggle switch and key switch are 3 position switches with the following options:

NORMAL – The fire/smoke damper remains open until closed by elevated temperatures.

CLOSED – The fire/smoke damper closes and remains closed regardless of any sensor signal.

OPEN – The fire/smoke damper opens and remains open until any temperature sensor signals the damper to close.



MCP1/14

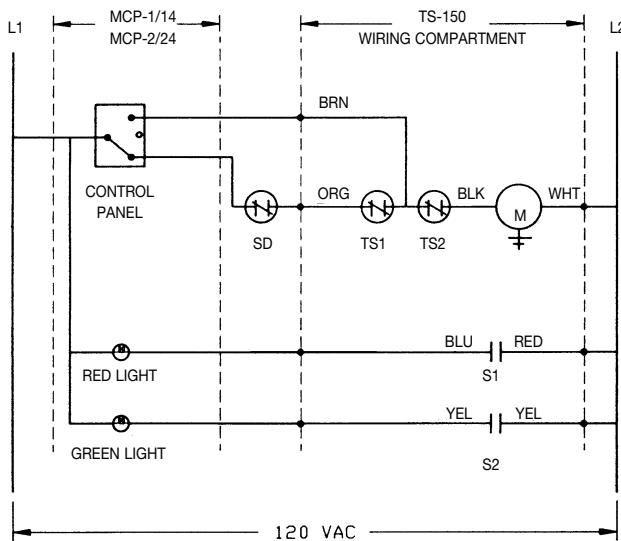

MCP2/24

- M – Electric Actuator or EP Switch
- TS1 – Primary Temp. Sensor
- TS2 – High Limit Temp. Sensor
- S1 – Damper Position Indication Switch, closed when damper is closed.
- S2 – Damper Position Indication Switch, closed when damper is open.
- SD – Smoke Detector (optional, by others)

MCP CONTROL PANELS MCP10, MCP104, MCP20 & MCP204

APPLICATION

These master control panels are for use in dynamic smoke management systems containing combination fire/smoke dampers equipped with the Lau TS150 FireStat.

FEATURES

The MCP10 with ten control stations and the MCP20 with 20 control stations offer completely enclosed lights, switches and wiring terminals located within and protected by a hinged, lockable cover with viewing windows. Damper position indicator lights are replaceable and are red for a closed damper and green for an open damper. MCP10 and MCP20 are for 120 VAC applications while the MCP104 and 204 are for 24 VAC applications.

The switch used on the MCP10/104 and the MCP20/204 is a three position with the following options:

NORMAL position – The damper functions as a fire damper by remaining open until closed by elevated temperatures.

The damper may also be closed by smoke detector signal, fan interlock contact, etc.

CLOSED position – The damper closes and remains closed regardless of any sensor signal.

OPEN position – The damper opens and remains open until any optional sensor signals the damper to close and lock.

M – Electric Actuator or EP Switch

TS1 – Primary Temp. Sensor

TS2 – High Limit Temp. Sensor

S1 – Damper Position Indication Switch, closed when damper is closed.

S2 – Damper Position Indication Switch, closed when damper is open.

SD – Smoke Detector (optional, by others)



MCP20

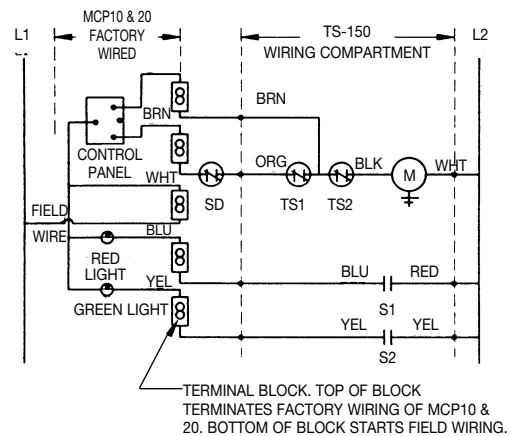

Damper Accessories

TERMINAL NO.	1	2	3	4	5	6	7	8	9	10	
BLUE	⊗	○	○	○	○	○	○	○	○	○	RED LIGHT
YELLOW	⊗	○	○	○	○	○	○	○	○	○	GREEN LIGHT
BLACK	⊗	○	○	○	○	○	○	○	○	○	TOGGLE SWITCH
WHITE	⊗	○	○	○	○	○	○	○	○	○	TOGGLE SWITCH
BROWN											
TYPICAL WIRING EACH CHANNEL											
TOGGLE SWITCH UP MAKES WHITE TO BROWN (NORMAL POS. DAMPER OPEN) CENTER POS. OFF (DAMPER CLOSED) DOWN MAKES WHITE TO BLACK (DAMPER OPEN FOR EMERGENCY)											
TERMINAL NO.	11	12	13	14	15	16	17	18	19	20	
BLUE	⊗	○	○	○	○	○	○	○	○	○	RED LIGHT
YELLOW	⊗	○	○	○	○	○	○	○	○	○	GREEN LIGHT
BLACK	⊗	○	○	○	○	○	○	○	○	○	TOGGLE SWITCH
WHITE	⊗	○	○	○	○	○	○	○	○	○	TOGGLE SWITCH
BROWN											
TYPICAL WIRING EACH CHANNEL											

**CONTROL PANEL LAYOUT
FOR MCP10 AND MCP20**

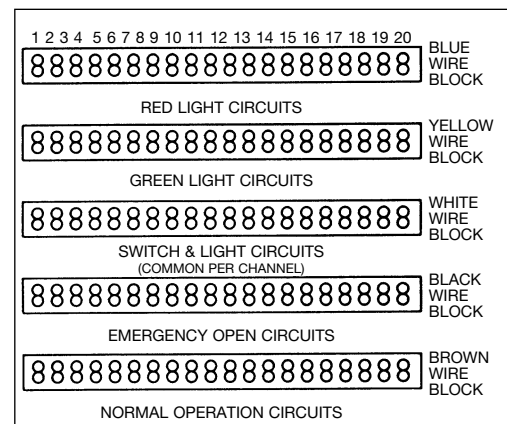

**TERMINAL PANEL LAYOUT
FOR MCP10 AND MCP20**

Specifications are subject to change without notice or obligation

SP100 SWITCH PACKAGE

APPLICATION

The SP100 Switch Package used with a control damper, smoke damper or Fire/Smoke damper, provides the ability to remotely indicate blade position. Electrical interface with remote control on/off fan stations is also possible with the SP100.

OPERATION

The SP100 Switch Package consists of a switch box containing two damper position indicator switches. One switch closes when the blades are fully open and the second switch closes when the blades are fully closed. The switches positively communicate to the fire commander the position of the blades when interfaced with the fire command center.

Refer to the appropriate damper installation instructions for details on damper installation. All electrical wiring and connections to the SP100 must be in accordance with the National Electric code and the local authority with jurisdiction.

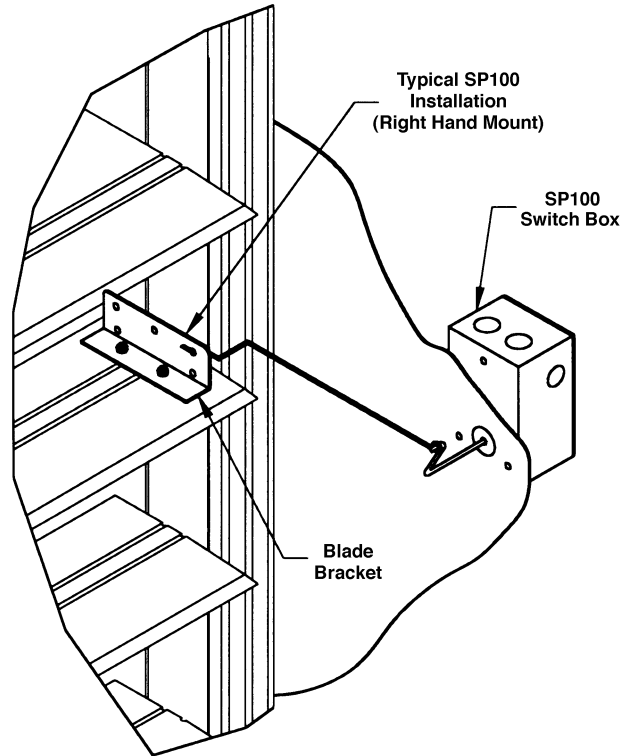

SP100 DIMENSIONS

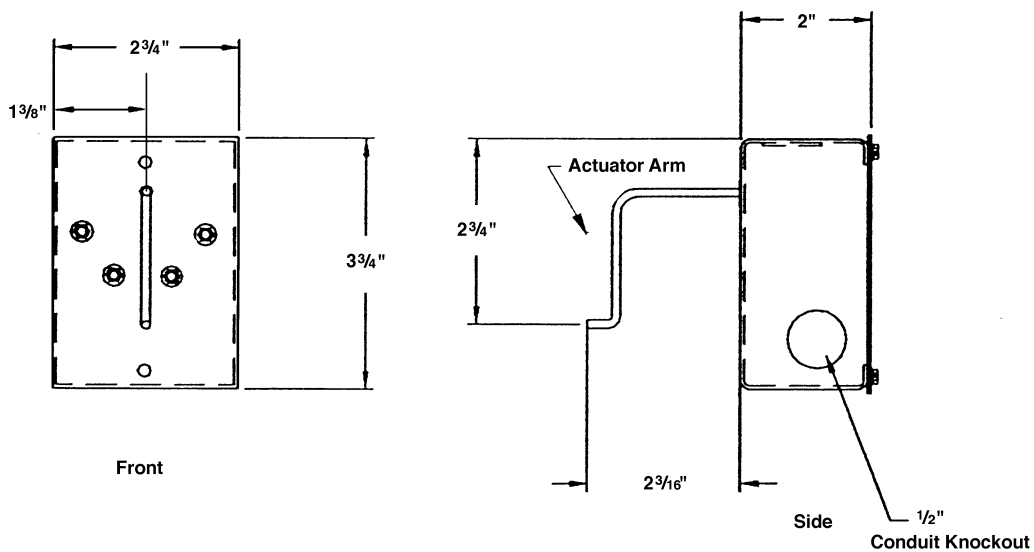

Specifications are subject to change without notice or obligation

- S - Damper position indicator switch. Closed (makes) when damper is open.
 - S - Damper position indicator switch. Closed (makes) when damper is closed.
 - B - Remote position indicator lamp.
 - B - Remote position indicator lamp.
- *Remote command station is provided by others.

WIRING

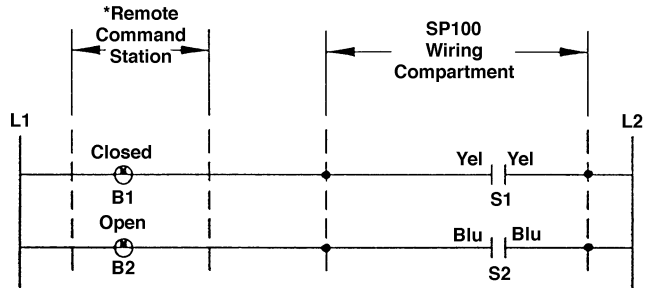

RIGHT HAND MOUNT

LAYOUT

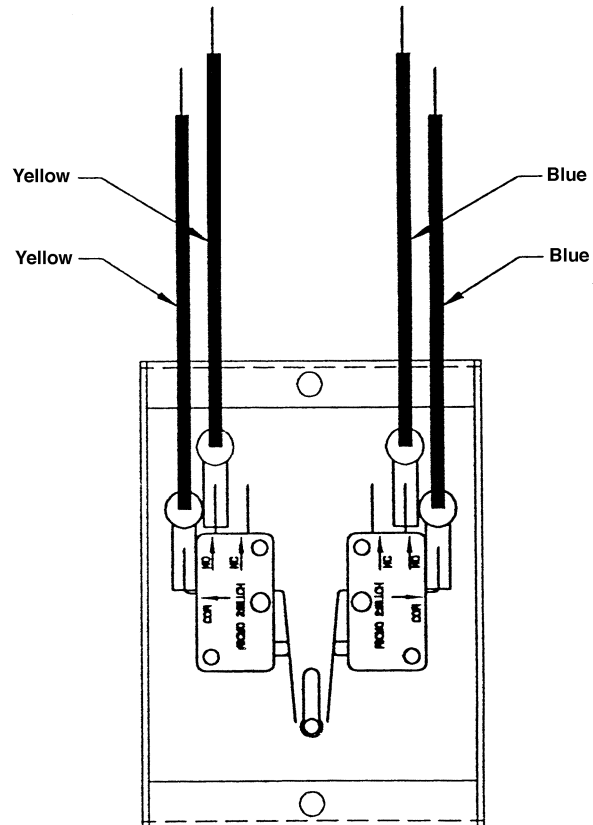

SP100 Indicator Switches
(contained within Switch Box)

MICRO SWITCH SPECIFICATIONS

High temperature to 302°F; Single pole, double throw

AMP Ratings:

- 15 AMPS, 1/3 HP, 125 or 250 VAC
- 1/2 AMP, 125 VDC, 1/4 AMP, 250 VDC
- 5 AMPS, 120 VAC "L" (Lamp Load)
- 24 VDC, 1.5 AMPS
- 24 VAC, 10 AMPS

WHY USE A LAU EXTRUDED ALUMINUM LOUVER?

Lau's extruded aluminum louvers are engineered to endure the stringent criteria of hurricane force winds and flying debris. Our in-house, computer-aided design capabilities and air performance testing laboratory for research and development continually test wind and rain conditions making sure our louvers are suitable for severe weather applications.

Lau offers several models of louvers including extruded aluminum, formed steel, stationary, combination, operable, and acoustical. Our louvers are available for standard and special needs, such as high-volume airflow, wind driven rain, special architectural shapes, sight proof, and security applications and offer a 20-year warranty.

WHICH LOUVER DO I NEED?

Thin-Line Stationary louvers are commonly used with air conditioner (PTAC) units or for decorative architectural applications. These louvers provide a high free area with limited weather protection.

General Purpose Stationary louvers are designed for applications that require intake and exhaust ventilation with moderate protection against water penetration. Models are available with drainable blades or drainable head and blades.

High Performance Stationary louvers are designed to minimize water penetration through wall openings. Models are available with drainable blades or drainable head and blades.

Combination louvers incorporate stationary and adjustable blades in a single frame and offer constant exterior appearance yet afford optimum control of intake and exhaust airflow through operation of the adjustable blades.

Adjustable louvers are designed to permit air intake and exhaust ventilation in exterior walls. When closed, extruded aluminum adjustable louver blades may be rotated to resist air leakage and water penetration.

WHICH KYNAR FINISH?

- **Kynar 500 finish** offers the best overall performance and can be computer formulated in-house to match an almost endless range of custom colors.
- **Standard 50% Kynar finish** economically provides the same color matching capability and excellent performance.
- **Acrodize Hardcoat 50% Kynar finish** furnishes a metallic sheen similar to anodize and metallic paints.

LOUVER TABLE OF CONTENTS

General Information	198
Thin Line Stationary	
CSE20	199
CSE20D	200
General Purpose Stationary	
CSE800	201
CSE800D - Drainable	202
High Performance Stationary	
CSE400	203
CSE400D - Drainable	204
CSE400 & CSE400D - Performance Data	205
CSE600	206
CSE600D - Drainable	207
Combination Louver	
CL600DX - Drainable	208-209
CL400D - Drainable	210-211
Adjustable	
AL600D - Drainable	212-213

CSE20 Thin Line Stationary 2" Deep, 45° Blade Angle

STANDARD CONSTRUCTION

FRAME

2" deep 6063T5 extruded aluminum with .060" nominal wall thickness. Caulking surfaces provided.

BLADES

6063T5 extruded aluminum with .060" nominal wall thickness. Blades are positioned at 45° angle and spaced approximately 3^{3/16}" center to center.

SCREEN

3/4" x .051" expanded, flattened aluminum bird screen in removable frame. Screen adds approximately 1/2" to louver depth.

FINISH

Mill.

MINIMUM SIZE

6"w x 10"h

APPROXIMATE SHIPPING WEIGHT

2 lbs. per sq. ft.

MAXIMUM SIZE

Shall be 75 sq. ft. per section, not to exceed 120"w x 90"h or 90"w x 120"h. Louvers larger than the maximum factory assembly size will require field assembly of smaller sections.

SUPPORTS

Louvers may be provided with rear mounted blade supports that increase overall louver depth depending on louver size, assembly configuration or windload.

VARIATIONS

Variations to the basic design of the louver are available at additional cost. They include:

- Extended sill.
- Hinged frame.
- Front or rear security bars.
- Filter racks.
- Installation angles.
- A variety of bird and insect screens.
- Selection of finishes: prime coat, baked enamel (modified fluoropolymer), epoxy, Pearledize, Kynar, clear and color anodize (some variation in anodize color consistency is possible).

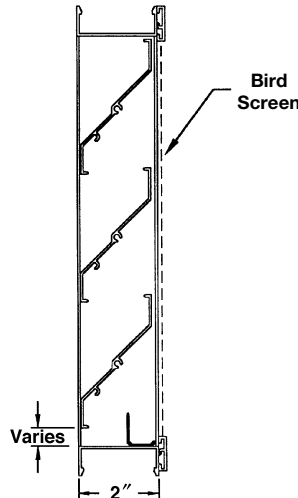
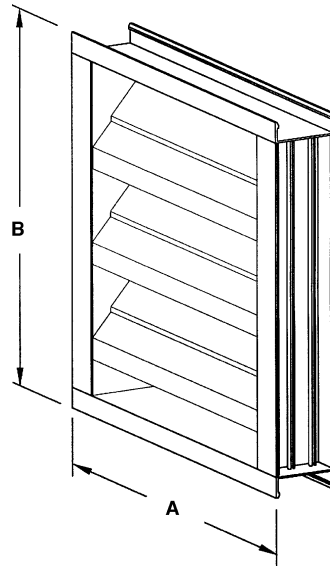

FEATURES

The CSE20 offers:

- 42% Free Area.
- Published performance ratings based on testing in accordance with AMCA Standard 500.
- Aluminum construction for low maintenance and high resistance to corrosion.

PERFORMANCE DATA

PRESSURE DROP

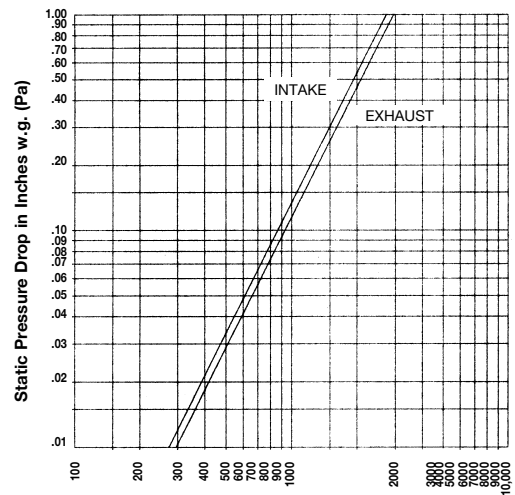

FREE AREA GUIDE

Free Area Guide shows free area in ft² and m² for various sizes of CSE20
Width – Inches and Meters

Height – Inches and Meters	12		18		24		30		36		42		48		54		60	
	0.30	0.46	0.61	0.76	0.91	1.07	1.22	1.37	1.52	1.67	1.82	1.97	2.12	2.27	2.42	2.57	2.72	2.87
12	0.26	0.41	0.56	0.71	0.86	1.01	1.16	1.31	1.46	1.61	1.76	1.91	2.06	2.21	2.36	2.51	2.66	2.81
0.30	0.02	0.04	0.05	0.07	0.08	0.09	0.11	0.12	0.14	0.15	0.17	0.18	0.20	0.21	0.23	0.24	0.26	0.27
18	0.45	0.71	0.96	1.22	1.48	1.73	1.99	2.25	2.50	2.76	3.01	3.27	3.52	3.78	4.03	4.29	4.54	4.80
0.46	0.04	0.07	0.09	0.11	0.14	0.16	0.19	0.21	0.23	0.26	0.28	0.31	0.33	0.35	0.38	0.40	0.42	0.44
24	0.76	1.20	1.63	2.07	2.50	2.94	3.37	3.81	4.24	4.67	5.10	5.53	5.96	6.39	6.82	7.25	7.68	8.11
0.61	0.07	0.11	0.15	0.19	0.23	0.27	0.31	0.35	0.39	0.43	0.47	0.51	0.55	0.59	0.63	0.67	0.71	0.75
30	0.95	1.49	2.03	2.57	3.12	3.66	4.20	4.74	5.29	5.82	6.36	6.90	7.44	7.98	8.52	9.06	9.60	10.14
0.76	0.09	0.14	0.19	0.24	0.29	0.34	0.39	0.44	0.49	0.54	0.59	0.64	0.69	0.74	0.79	0.84	0.89	0.94
36	1.14	1.78	2.43	3.08	3.73	4.38	5.03	5.68	6.33	6.97	7.62	8.27	8.92	9.57	10.22	10.87	11.52	12.17
0.91	0.11	0.17	0.23	0.29	0.35	0.41	0.47	0.53	0.59	0.65	0.71	0.77	0.83	0.89	0.95	1.01	1.07	1.13
42	1.32	2.08	2.83	3.59	4.35	5.10	5.86	6.61	7.37	8.12	8.88	9.63	10.39	11.14	11.90	12.65	13.41	14.16
1.07	0.05	0.08	0.11	0.14	0.17	0.20	0.23	0.26	0.29	0.32	0.35	0.38	0.41	0.44	0.47	0.50	0.53	0.56
48	1.51	2.37	3.23	4.10	4.96	5.82	6.69	7.55	8.41	9.27	10.13	11.00	11.86	12.72	13.58	14.44	15.30	16.16
1.22	0.14	0.22	0.30	0.38	0.46	0.54	0.62	0.70	0.78	0.86	0.94	1.02	1.10	1.18	1.26	1.34	1.42	1.50
54	1.70	2.67	3.64	4.60	5.57	6.54	7.51	8.48	9.45	10.42	11.39	12.36	13.33	14.30	15.27	16.24	17.21	18.18
1.37	0.16	0.25	0.34	0.43	0.52	0.61	0.70	0.79	0.88	0.97	1.06	1.15	1.24	1.33	1.42	1.51	1.60	1.69
60	1.88	2.96	4.04	5.11	6.19	7.26	8.34	9.42	10.49	11.57	12.64	13.72	14.80	15.88	16.95	18.03	19.11	20.19
1.52	0.18	0.28	0.38	0.48	0.58	0.68	0.78	0.88	0.98	1.08	1.18	1.28	1.38	1.48	1.58	1.68	1.78	1.88
66	2.20	3.45	4.71	5.96	7.21	8.47	9.72	10.98	12.23	13.49	14.74	16.00	17.25	18.50	19.75	21.00	22.25	23.50
1.68	0.20	0.32	0.44	0.55	0.67	0.79	0.90	1.02	1.14	1.26	1.38	1.50	1.62	1.74	1.86	1.98	2.10	2.22
72	2.38	3.74	5.11	6.47	7.83	9.19	10.55	11.91	13.27	14.63	16.00	17.36	18.72	20.08	21.44	22.80	24.16	25.52
1.83	0.22	0.35	0.47	0.60	0.73	0.85	0.98	1.11	1.23	1.36	1.49	1.62	1.75	1.88	2.01	2.14	2.27	2.40

FRAME CONSTRUCTION

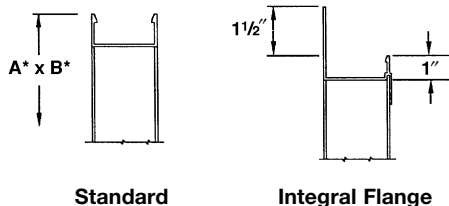

EXTRUDED ALUMINUM LOUVERS



CSE20D

Thin Line Stationary, Drainable
2" Deep, 45° Blade Angle

STANDARD CONSTRUCTION

FRAME

2" deep 6063T5 extruded aluminum, .060" nominal wall thickness. Downspouts and caulking surfaces provided.

BLADES

6063T5 extruded aluminum, .060" nominal wall thickness. Drainable blades are positioned at 45° angle and spaced approximately 2 7/16" center to center.

SCREEN

3/4"x .051" expanded, flattened aluminum bird screen in removable frame. Screen adds approximately 1/2" to louver depth.

FINISH

Mill.

MINIMUM SIZE

6"w x 10"h

APPROXIMATE SHIPPING WEIGHT

2 lbs. per sq. ft.

MAXIMUM SIZE

Shall be 75 sq. ft. per section, not to exceed 120"w x 90"h or 90"w x 120"h. Louvers larger than the maximum factory assembly size will require field assembly of smaller sections.

SUPPORTS

Louvers may be provided with rear mounted Hidden Vertical Blade Supports that increase overall louver depth depending on louver size, assembly configuration or windload.

VARIATIONS

Variations to the basic design of the louver are available at additional cost. They include:

- Extended sill.
- Hinged frame.

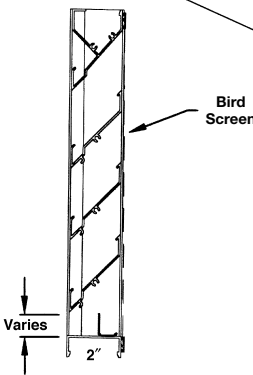
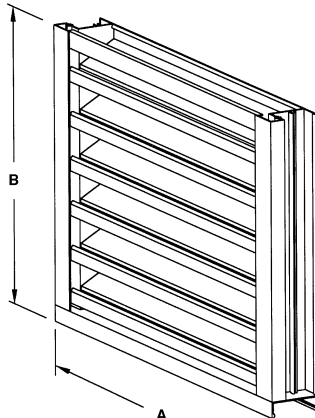

FRAME CONSTRUCTION

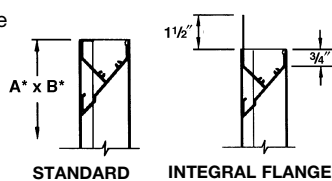

VARIATIONS (con't.)

- Front or rear security bars.
- Filter racks.
- Installation angles.
- A variety of bird and insect screens.
- Selection of finishes: prime coat, baked enamel (modified fluoropolymer), epoxy, Pearledize, Kynar, clear and color anodize (some variation in anodize color consistency is possible).

FEATURES

The CSE20D offers:

- 38% Free Area.
- Published performance ratings based on testing in accordance with AMCA Publication 500.
- High performance frame system with drainable head collects and removes water to provide excellent water penetration performance.
- Drain gutter in each blade minimizes water cascade between blades.
- Architecturally styled, hidden mullions allowing continuous blade appearance up to 120".
- All aluminum construction for low maintenance and high resistance to corrosion.

PERFORMANCE DATA

WATER PENETRATION

Test size 48" wide x 48" high
Beginning point of water penetration at .01 oz./sq. ft. is 1197 FPM.

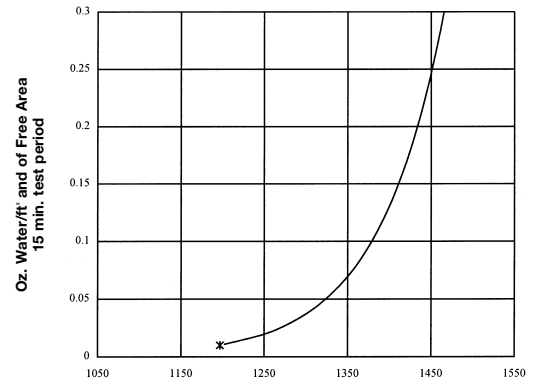

Free Area Velocity in feet per minute Standard air .075 lb/ft³

PRESSURE DROP

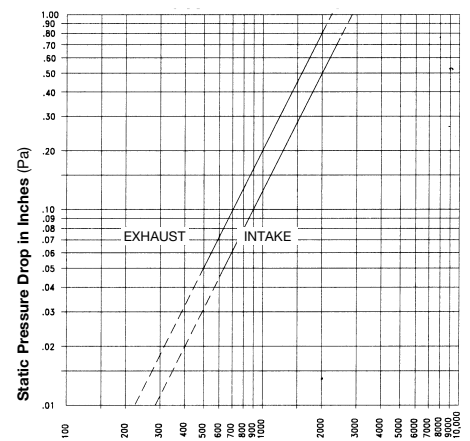

Air Velocity in feet/minute through Free Area
Ratings do not include the effect of a bird screen.

FREE AREA GUIDE

Free Area Guide shows free area in ft² and m² of various sizes of CSE20D

	12	18	24	30	36	42	48	54	60	66	72	78	84	90	96	102	108	114	120
12	0.30	0.46	0.61	0.76	0.91	1.07	1.22	1.37	1.52	1.68	1.83	1.98	2.13	2.29	2.44	2.59	2.74	2.90	3.05
0.30	0.03	0.04	0.06	0.08	0.09	0.11	0.12	0.14	0.16	0.17	0.19	0.20	0.22	0.24	0.25	0.27	0.28	0.30	0.32
18	0.53	0.84	1.14	1.45	1.75	2.05	2.36	2.66	2.97	3.27	3.58	3.88	4.18	4.49	4.79	5.10	5.40	5.71	6.01
0.46	0.05	0.08	0.11	0.13	0.16	0.19	0.22	0.25	0.28	0.30	0.33	0.36	0.39	0.42	0.45	0.47	0.50	0.53	0.56
24	0.66	1.04	1.42	1.79	2.17	2.55	2.93	3.31	3.68	4.06	4.44	4.82	5.19	5.57	5.95	6.33	6.71	7.08	7.46
0.61	0.06	0.10	0.13	0.17	0.20	0.24	0.27	0.31	0.34	0.38	0.41	0.45	0.48	0.52	0.55	0.59	0.62	0.66	0.69
30	0.89	1.40	1.91	2.42	2.93	3.44	3.95	4.46	4.97	5.48	5.99	6.50	7.01	7.52	8.03	8.54	9.05	9.56	10.07
0.76	0.08	0.13	0.18	0.23	0.27	0.32	0.37	0.42	0.46	0.51	0.56	0.60	0.65	0.70	0.75	0.79	0.84	0.89	0.94
36	1.02	1.60	2.19	2.77	3.36	3.94	4.52	5.11	5.69	6.27	6.86	7.44	8.02	8.61	9.19	9.77	10.36	10.94	11.52
0.91	0.09	0.15	0.20	0.26	0.31	0.37	0.42	0.47	0.53	0.58	0.64	0.69	0.75	0.80	0.85	0.91	0.96	1.02	1.07
42	1.25	1.97	2.68	3.40	4.12	4.83	5.55	6.26	6.98	7.70	8.41	9.13	9.84	10.56	11.27	11.99	12.71	13.42	14.14
1.07	0.12	0.18	0.25	0.32	0.38	0.45	0.52	0.58	0.65	0.72	0.78	0.85	0.92	0.98	1.05	1.12	1.18	1.25	1.31
48	1.38	2.17	2.96	3.75	4.54	5.33	6.12	6.91	7.70	8.48	9.27	10.06	10.85	11.64	12.43	13.22	14.01	14.80	15.59
1.22	0.13	0.20	0.28	0.35	0.42	0.50	0.57	0.64	0.72	0.79	0.86	0.94	1.01	1.08	1.16	1.23	1.30	1.38	1.45
54	1.61	2.53	3.46	4.38	5.30	6.22	7.14	8.06	8.99	9.91	10.83	11.75	12.67	13.59	14.51	15.44	16.36	17.28	18.20
1.37	0.15	0.24	0.32	0.41	0.49	0.58	0.66	0.75	0.84	0.92	1.01	1.09	1.18	1.26	1.35	1.44	1.52	1.61	1.69
60	1.74	2.74	3.73	4.73	5.72	6.72	7.71	8.71	9.70	10.70	11.69	12.69	13.68	14.68	15.67	16.67	17.66	18.66	19.65
1.52	0.16	0.25	0.35	0.44	0.53	0.62	0.72	0.81	0.90	0.99	1.09	1.18	1.27	1.36	1.46	1.55	1.64	1.74	1.83
66	1.97	3.10	4.23	5.35	6.48	7.61	8.74	9.86	10.99	12.12	13.25	14.37	15.50	16.63	17.76	18.88	20.01	21.14	22.26
1.68	0.18	0.29	0.39	0.50	0.60	0.71	0.81	0.92	1.02	1.13	1.23	1.34	1.44	1.55	1.65	1.76	1.86	1.97	2.07
72	2.20	3.46	4.72	5.98	7.24	8.50	9.76	11.02	12.28	13.54	14.80	16.06	17.32	18.58	19.84	21.10	22.36	23.62	24.88
1.83	0.21	0.32	0.44	0.56	0.67	0.79	0.91	1.03	1.14	1.26	1.38	1.49	1.61	1.73	1.85	1.96	2.08	2.20	2.31
78	2.33	3.67	5.00	6.33	7.67	9.00	10.33	11.66	13.00	14.33	15.66	17.00	18.33	19.66	21.00	22.33	23.66	25.00	26.33
1.98	0.22	0.34	0.46	0.59	0.71	0.84	0.96	1.08	1.21	1.33	1.46	1.58	1.70	1.83	1.95	2.08	2.20	2.32	2.45
84	2.56	4.03	5.50	6.96	8.43	9.89	11.36	12.82	14.29	15.75	17.22	18.68	20.15	21.61	23.08	24.55	26.01	27.48	28.94
2.13	0.24	0.37	0.51	0.65	0.78	0.92	1.06	1.19	1.33	1.47	1.60	1.74	1.87	2.01	2.15	2.28	2.42	2.56	2.69
90	2.69	4.23	5.77	7.31	8.85	10.39	11.93	13.46	15.00	16.54	18.08	19.62	21.16	22.70	24.24	25.78	27.31	28.85	30.39
2.29	0.25	0.39	0.54	0.68	0.82	0.97	1.11	1.25	1.40	1.54	1.68	1.82	1.97	2.11	2.25	2.40	2.54	2.68	2.83

Specifications are subject to change without notice or obligation

CSE800 General Purpose Stationary 4" Deep, 45° Blade Angle

STANDARD CONSTRUCTION

FRAME

4" deep, 6063T5 extruded aluminum with .080" nominal wall thickness. Box or integral flange frames are available. Caulking slots provided on box frame.

BLADES

6063T5 extruded aluminum with .063" nominal wall thickness. J-style blades (formerly "weather-proof") are positioned at 45° angle and spaced approximately 5" center to center.

SCREEN

3/4" x .051" expanded, flattened aluminum bird screen in removable frame. Screen adds approximately 1/2" to louver depth.

FINISH

Mill.

MINIMUM SIZE

12" w x 12" h

MAXIMUM SIZE

60" w x 60" h

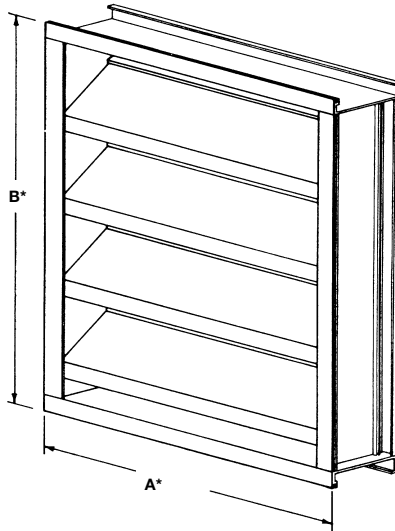

PERFORMANCE DATA

FREE AREA GUIDE

Free Area Guide shows free area in ft² and m² for various sizes of CSE800.

	12	18	24	30	36	42	48	54	60
	0.30	0.46	0.61	0.76	0.91	1.07	1.22	1.37	1.52
12	.17	.27	.37	.47	.57	.67	.77	.87	.98
0.30	.02	.03	.03	.04	.05	.06	.07	.08	.09
18	.42	.67	.93	1.18	1.44	1.69	1.95	2.20	2.46
0.46	.04	.06	.09	.11	.13	.16	.18	.20	.23
24	.67	1.08	1.49	1.90	2.31	2.72	3.13	3.54	3.95
0.61	.06	.10	.14	.18	.21	.25	.29	.33	.37
30	.91	1.47	2.03	2.59	3.15	3.71	4.27	4.83	5.38
0.76	.08	.14	.19	.24	.29	.34	.40	.45	.50
36	1.12	1.80	2.49	3.17	3.85	4.54	5.22	5.90	6.59
0.91	.10	.17	.23	.29	.36	.42	.48	.55	.61
42	1.28	2.06	2.84	3.62	4.40	5.18	5.96	6.74	7.52
1.07	.12	.19	.26	.34	.41	.48	.55	.63	.70
48	1.53	2.46	3.40	4.33	5.27	6.20	7.10	8.07	9.00
1.22	.14	.23	.32	.40	.49	.58	.66	.75	.84
54	1.78	2.87	3.96	5.05	6.14	7.23	8.32	9.41	10.50
1.37	.17	.27	.37	.47	.57	.67	.77	.87	.98
60	2.03	3.26	4.50	5.74	6.98	8.21	9.45	10.69	11.93
1.52	.19	.30	.42	.53	.65	.76	.88	.99	1.11

Height - Inches and Meters

Width - Inches and Meters

SUGGESTED INSTALLATION DETAILS

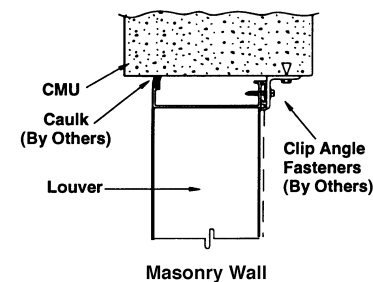

Masonry Wall

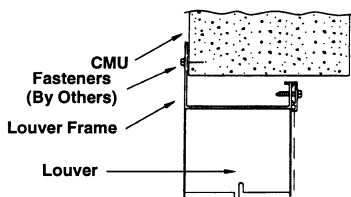

Flange Mount

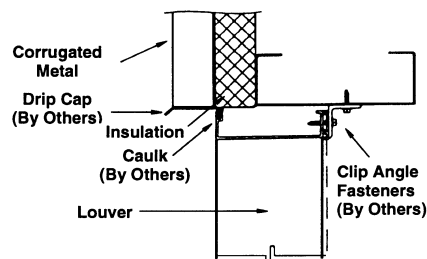
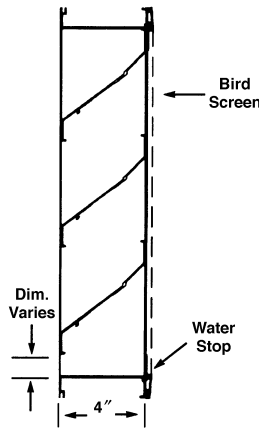

Metal Panel Wall

FRAME CONSTRUCTION (Specify one)

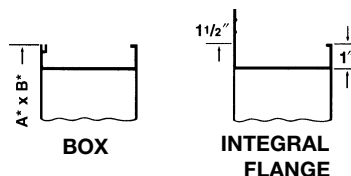

PRESSURE DROP

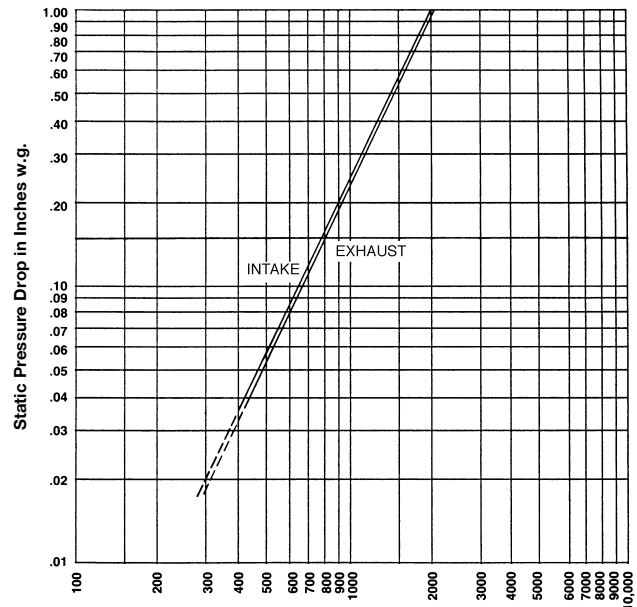

Air Velocity in feet per minute through Free Area

Ratings do not include the effect of a bird screen.

Unit furnished approximately 1/4" smaller than given opening dimensions.

Specifications are subject to change without notice or obligation

EXTRUDED ALUMINUM LOUVERS



CSE800D

General Purpose Stationary, Drainable

4" Deep, 45° Blade Angle

STANDARD CONSTRUCTION

FRAME

4" deep, 6063T5 extruded aluminum with .080" nominal wall thickness. Box or integral flange frames are available with integral downspouts. Caulking surfaces provided on box frame.

BLADES

6063T5 extruded aluminum with .063" nominal wall thickness. Drainable blades are positioned at 45° angle and spaced approximately 5" center to center.

SCREEN

3/4" x .051" expanded, flattened aluminum bird screen in removable frame. Aluminum 1/2" x .063" mesh bird or 18-16 mesh insect screens are also available. Screen adds approximately 1/2" to louver depth.

FINISH

Mill.

INSTALLATION ANGLES

1 1/2" x 1 1/2" x 1/8" thick x 2" long aluminum clip angles with holes and two #10 self drilling screws (clip to louver) provided loose (clip to wall fasteners not included). Install clips 6" max. from ends and at 24" max. between for 20 PSF windload.

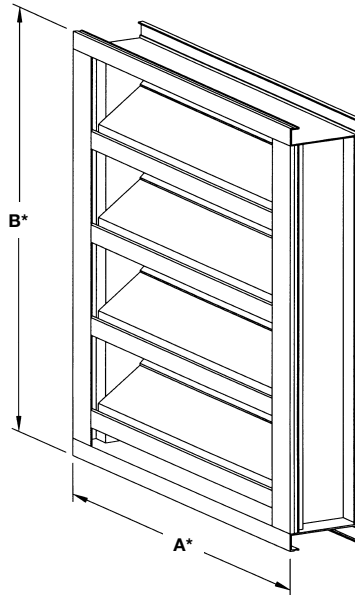

MINIMUM SIZE

12"w x 12"h

MAXIMUM SIZE

60"w x 60"h

PERFORMANCE DATA

FREE AREA GUIDE

Free Area Guide shows free area in ft² and m² for various sizes of CSE800D.

	12	18	24	30	36	42	48	54	60
	0.30	0.46	0.61	0.76	0.91	1.07	1.22	1.37	1.52
12	.17	.27	.38	.48	.58	.69	.79	.90	1.00
	0.30	.02	.03	.04	.05	.06	.07	.08	.09
18	.43	.69	.95	1.20	1.46	1.72	1.98	2.24	2.49
	0.46	.04	.06	.09	.11	.14	.16	.18	.21
24	.69	1.11	1.52	1.93	2.35	2.76	3.18	3.59	4.01
	0.61	.06	.10	.14	.18	.22	.26	.30	.33
30	.95	1.52	2.09	2.66	3.23	3.81	4.38	4.95	5.52
	0.76	.09	.14	.19	.245	.230	.35	.401	.456
36	1.21	1.94	2.67	3.39	4.12	4.85	5.58	6.30	7.03
	0.91	.11	.18	.25	.32	.38	.45	.52	.59
42	1.25	2.04	2.83	3.62	4.41	5.20	5.99	6.78	7.57
	1.07	.12	.19	.26	.34	.41	.48	.56	.63
48	1.58	2.57	3.47	4.42	5.36	6.31	7.26	8.20	9.15
	1.22	.15	.23	.32	.41	.50	.59	.67	.76
54	1.84	2.94	4.04	5.15	6.25	7.35	8.46	9.56	10.66
	1.37	.17	.27	.38	.48	.58	.68	.79	.89
60	2.10	3.36	4.62	5.88	7.14	8.40	9.66	10.91	12.17
	1.52	.20	.31	.43	.55	.66	.78	.90	1.01

Height & Width - Inches and Meters

SUGGESTED INSTALLATION DETAILS

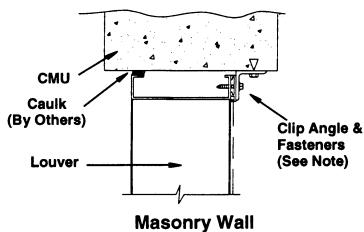

Masonry Wall

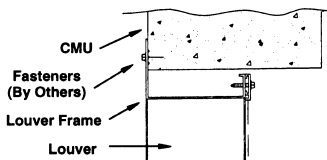

Flange Mount

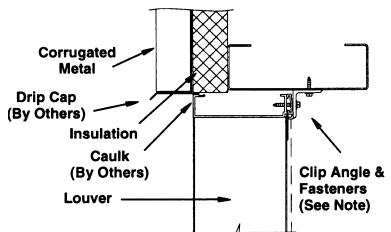

Metal Panel Wall

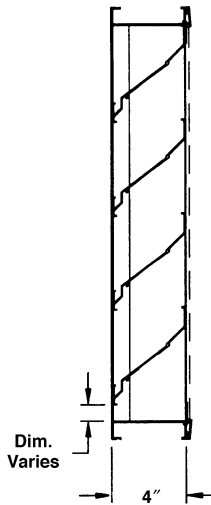

FRAME CONSTRUCTION (Specify one)

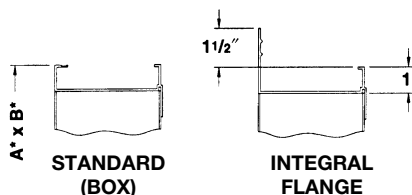

PRESSURE DROP

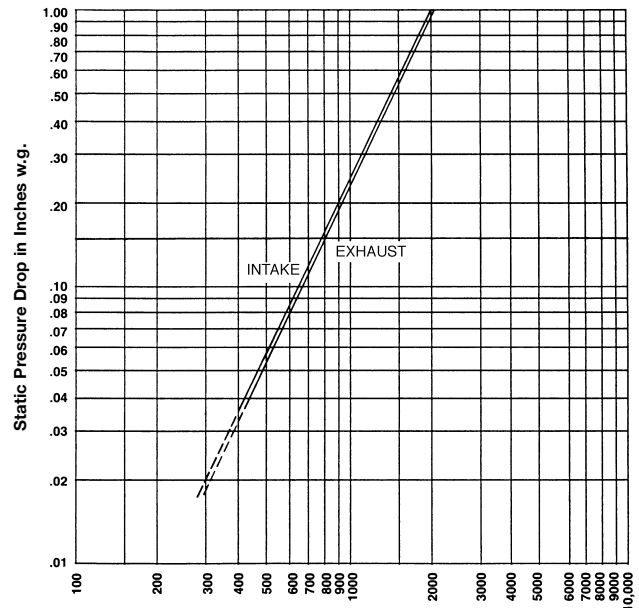

Air Velocity in feet per minute through Free Area

Ratings do not include the effect of a bird screen.

Unit furnished approximately 1/4" smaller than given opening dimensions.

Specifications are subject to change without notice or obligation

CSE400 High Performance Stationary 4" Deep, 37½° Blade Angle

STANDARD CONSTRUCTION

FRAME

4" deep, 6063T5 extruded aluminum. .081" nominal wall thickness. Down-spouts and caulking surfaces provided.

BLADES

6063T5 extruded aluminum. .081" nominal wall thickness. Blades are positioned at 37½° angle and spaced approximately 5³/₃₂" center to center.

SCREEN

3/4" x .051" expanded, flattened aluminum bird screen in removable frame. Screen adds approximately 1/2" to louver depth.

FINISH

Mill.

MINIMUM SIZE

12"w x 12"h

APPROXIMATE SHIPPING WEIGHT

4 lbs./ft.².

MAXIMUM FACTORY ASSEMBLY SIZE

Shall be 75 sq. ft. per section, not to exceed 120"w x 90"h or 90"w x 120"h. Louvers larger than the maximum factory assembly size will require field assembly of smaller sections.

SUPPORTS

Louvers may be provided with rear mounted blade supports that increase overall louver depth depending on louver size, assembly configuration or windload.

VARIATIONS

Variations to the basic design of these louvers are available at additional cost. They include:

- Extended sill.
- Hinged frame.
- Front or rear security bars.
- Filter racks.
- A variety of bird and insect screens.
- Selection of finishes: prime coat, baked enamel (modified fluoropolymer), epoxy, Pearledize, Kynar, clear and color anodize (some variation in anodize color consistency is possible).

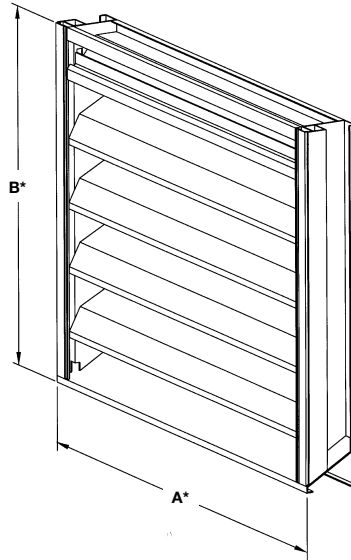

FEATURES

The CSE400 offers:

- 54% Free Area.
- Published performance ratings based on testing in accordance with AMCA Publication 511.
- High performance frame system with drainable head collects and removes water to provide excellent water penetration performance.
- Architecturally styled, hidden mullions allowing continuous line appearance up to 120".
- Aluminum construction for low maintenance and high resistance to corrosion.
- All welded construction.

PERFORMANCE DATA

AMCA Standard 500 provides a reasonable basis for testing and rating louvers. Testing to AMCA 500 is performed under a certain set of laboratory conditions. This does not guarantee that other conditions will not occur in the actual environment where louvers must operate.

The louver system should be designed with a reasonable safety factor for louver performance. To ensure protection from water carryover, design with a performance level somewhat below maximum desired pressure drop and .01 oz./sq. ft. of water penetration.

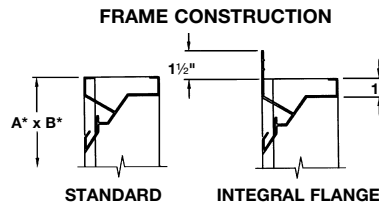

WATER PENETRATION

Test size 48" wide x 48" high
Beginning point of water penetration at
.01 oz./sq. ft. is 803 FPM.

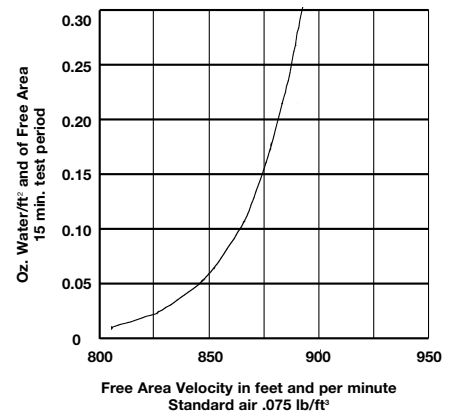

PRESSURE DROP

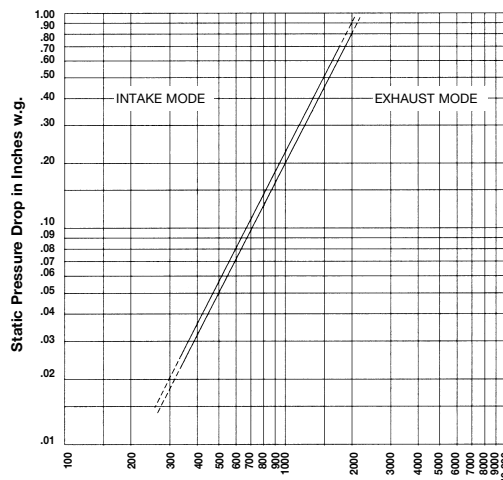

Air Velocity in feet per minute through Free Area

Ratings do not include the effect of a bird screen.



Unit furnished approximately 1/4" smaller than given opening dimensions. Consult Lau for other special requirements or additional information.



See chart on Page 205 for Free Area Guide.

EXTRUDED ALUMINUM LOUVERS



CSE400D

High Performance Stationary, Drainable

4" Deep, 37 1/2° Blade Angle

STANDARD CONSTRUCTION

FRAME

4" deep, 6063T5 extruded aluminum. .081" nominal wall thickness. Downspouts and caulking surfaces provided.

BLADES

6063T5 extruded aluminum. .081" nominal wall thickness. Drainable blades are positioned at 37 1/2° angle and spaced approximately 5 3/32" center to center.

SCREEN

3/4" x .051" expanded, flattened aluminum bird screen in removable frame. Screen adds approximately 1/2" to louver depth.

FINISH

Mill.

MINIMUM SIZE

12" w x 12" h

APPROXIMATE SHIPPING WEIGHT

4 lbs./ft.²

MAXIMUM FACTORY ASSEMBLY SIZE

Shall be 75 sq. ft. per section, not to exceed 120" w x 90" h or 90" w x 120" h. Louvers larger than the maximum factory assembly size will require field assembly of smaller sections.

SUPPORTS

Louvers may be provided with rear mounted blade supports that increase overall louver depth depending on louver size, assembly configuration or windload.

VARIATIONS

Variations to the basic design of these louvers are available at additional cost. They include:

- Extended sill.
- Hinged frame.
- Front or rear security bars.
- Filter racks.
- A variety of bird and insect screens.
- Selection of finishes: prime coat, baked enamel (modified fluoropolymer), epoxy, Pearledize, Kynar, clear and color anodize (some variation in anodize color consistency is possible).

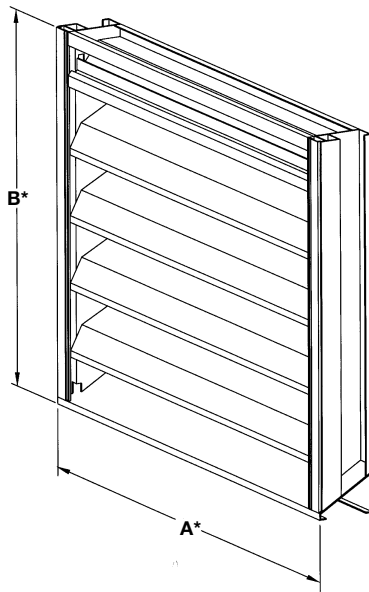

FEATURES

The CSE400D offers:

- 54% Free Area.
- Published performance ratings based on testing in accordance with AMCA Publication 511.
- High performance frame system with drainable head collects and removes water to provide excellent water penetration performance.
- Drain gutter in each blade minimizes water cascade between blades.
- Architecturally styled, hidden mullions allowing continuous line appearance up to 120".
- Aluminum construction for low maintenance and high resistance to corrosion.
- All welded construction.

PERFORMANCE DATA

AMCA Standard 500 provides a reasonable basis for testing and rating louvers. Testing to AMCA 500 is performed under a certain set of laboratory conditions. This does not guarantee that other conditions will not occur in the actual environment where louvers must operate.

The louver system should be designed with a reasonable safety factor for louver performance. To ensure protection from water carryover, design with a performance level somewhat below maximum desired pressure drop and .01 oz./sq. ft. of water penetration.

FRAME CONSTRUCTION

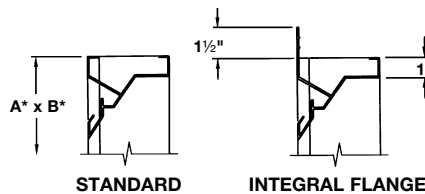

PRESSURE DROP

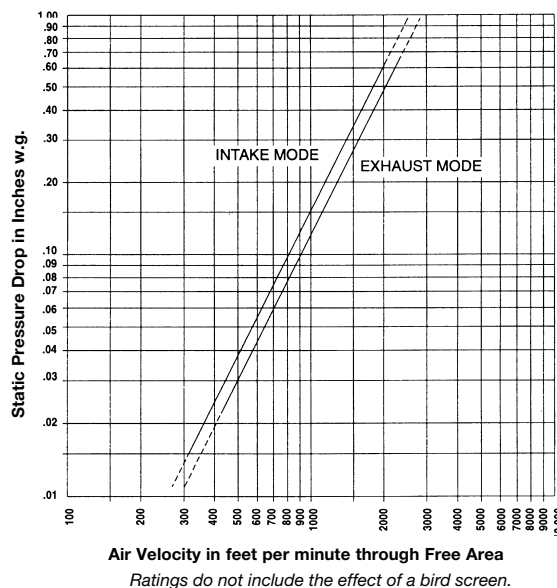

WATER PENETRATION

Test size 48" wide x 48" high
Beginning point of water penetration at .01 oz./sq. ft. is 873 FPM.

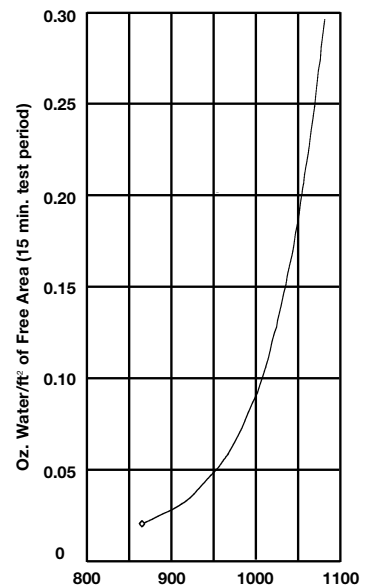

See chart on **PG. 207** for Free Area Guide.

Unit furnished approximately 1/4" smaller than given opening dimensions.
Consult Lau for other special requirements or additional information.

Specifications are subject to change without notice or obligation

CSE400 & CSE400D High Performance Stationary 4" Deep, 37½° Blade Angle

CSE400 & CSE400D PERFORMANCE DATA

The actual pressure drop through a damper is the result of many factors. The formula and area factor table below may be used to estimate pressure drop for a CSE400 & CSE400D of a given size, with straight duct runs upstream and downstream, as in AMCA Figure 5.3.

FREE AREA GUIDE

Free Area Guide shows free area in ft² and m² for various sizes of CSE400 & CSE400D.

	12	18	24	30	36	42	48	54	60	66	72	78	84	90	96	102	108	114	120
	0.30	0.46	0.61	0.76	0.91	1.07	1.22	1.37	1.52	1.68	1.83	1.98	2.13	2.29	2.44	2.59	2.74	2.90	3.05
12	0.26	0.41	0.56	0.71	0.87	1.02	1.17	1.33	1.48	1.63	1.79	1.94	2.09	2.24	2.40	2.55	2.70	2.86	3.01
0.30	0.02	0.04	0.05	0.07	0.08	0.09	0.11	0.12	0.14	0.15	0.17	0.18	0.19	0.21	0.22	0.24	0.25	0.27	0.28
18	0.61	0.97	1.33	1.70	2.06	2.43	2.79	3.15	3.52	3.88	4.25	4.61	4.97	5.34	5.70	6.06	6.43	6.79	7.16
0.46	0.06	0.09	0.12	0.16	0.19	0.23	0.26	0.29	0.33	0.36	0.39	0.43	0.46	0.50	0.53	0.56	0.60	0.63	0.67
24	0.87	1.40	1.92	2.45	2.97	3.50	4.02	4.55	5.07	5.60	6.12	6.65	7.17	7.70	8.22	8.75	9.27	9.80	10.32
0.61	0.08	0.13	0.18	0.23	0.28	0.33	0.37	0.42	0.47	0.52	0.57	0.62	0.67	0.72	0.76	0.81	0.86	0.91	0.96
30	1.14	1.83	2.51	3.20	3.89	4.57	5.26	5.94	6.63	7.33	8.00	8.69	9.37	10.06	10.74	11.43	12.12	12.80	13.49
0.76	0.11	0.17	0.23	0.30	0.36	0.42	0.49	0.55	0.62	0.68	0.74	0.81	0.87	0.93	1.00	1.06	1.13	1.19	1.25
36	1.33	2.13	2.92	3.72	4.52	5.31	6.11	6.91	7.70	8.50	9.30	10.09	10.89	11.69	12.49	13.28	14.08	14.88	15.67
0.91	0.12	0.20	0.27	0.35	0.42	0.49	0.57	0.64	0.72	0.79	0.86	0.94	1.01	1.09	1.16	1.23	1.31	1.38	1.46
42	1.60	2.55	3.51	4.47	5.43	6.39	7.34	8.30	9.26	10.22	11.18	12.13	13.09	14.05	15.01	15.96	16.92	17.88	18.84
1.07	0.15	0.24	0.33	0.42	0.50	0.59	0.68	0.77	0.86	0.95	1.04	1.13	1.22	1.31	1.39	1.48	1.57	1.66	1.75
48	1.86	2.98	4.10	5.22	6.34	7.46	8.58	9.70	10.82	11.93	13.05	14.17	15.29	16.41	17.53	18.65	19.77	20.89	22.00
1.22	0.17	0.28	0.38	0.49	0.59	0.69	0.80	0.90	1.01	1.11	1.21	1.32	1.42	1.52	1.63	1.73	1.84	1.94	2.04
54	2.13	3.41	4.69	5.97	7.25	8.53	9.81	11.09	12.37	13.65	14.93	16.21	17.49	18.77	20.05	21.33	22.61	23.89	25.17
1.37	0.20	0.32	0.44	0.55	0.67	0.79	0.91	1.03	1.15	1.27	1.39	1.51	1.63	1.74	1.86	1.98	2.10	2.22	2.34
60	2.40	3.84	5.28	6.72	8.16	9.61	11.05	12.49	13.93	15.37	16.81	18.25	19.69	21.13	22.57	24.01	25.45	26.90	28.34
1.52	0.22	0.36	0.49	0.62	0.76	0.89	1.03	1.16	1.29	1.43	1.56	1.70	1.83	1.96	2.10	2.23	2.37	2.50	2.63
66	2.59	4.14	5.69	7.24	8.79	10.35	11.90	13.45	15.00	16.55	18.11	19.66	21.21	22.76	24.31	25.86	27.42	28.97	30.52
1.68	0.24	0.38	0.53	0.67	0.82	0.96	1.11	1.25	1.39	1.54	1.68	1.83	1.97	2.12	2.26	2.40	2.55	2.69	2.84
72	2.85	4.57	6.28	7.99	9.71	11.42	13.13	14.84	16.56	18.27	19.98	21.70	23.41	25.12	26.83	28.55	30.26	31.97	33.69
1.83	0.26	0.42	0.58	0.74	0.90	1.06	1.22	1.38	1.54	1.70	1.86	2.02	2.18	2.33	2.49	2.65	2.81	2.97	3.13
78	3.12	5.00	6.87	8.74	10.62	12.49	14.37	16.24	18.11	19.99	21.86	23.74	25.61	27.48	29.36	31.23	33.10	34.98	36.85
1.98	0.29	0.46	0.64	0.81	0.99	1.16	1.34	1.51	1.68	1.86	2.03	2.21	2.38	2.55	2.73	2.90	3.08	3.25	3.42
84	3.39	5.43	7.46	9.50	11.53	13.57	15.60	17.63	19.67	21.70	23.74	25.77	27.81	29.84	31.88	33.91	35.95	37.98	40.02
2.13	0.32	0.50	0.69	0.88	1.07	1.26	1.45	1.64	1.83	2.02	2.21	2.39	2.58	2.77	2.96	3.15	3.34	3.53	3.72
90	3.66	5.86	8.05	10.25	12.44	14.64	16.83	19.03	21.23	23.42	25.62	27.81	30.01	32.20	34.40	36.60	38.79	40.99	43.18
2.29	0.34	0.54	0.75	0.95	1.16	1.36	1.56	1.77	1.97	2.18	2.38	2.58	2.79	2.99	3.20	3.40	3.60	3.81	4.01

TYPICAL INSTALLATION DETAILS

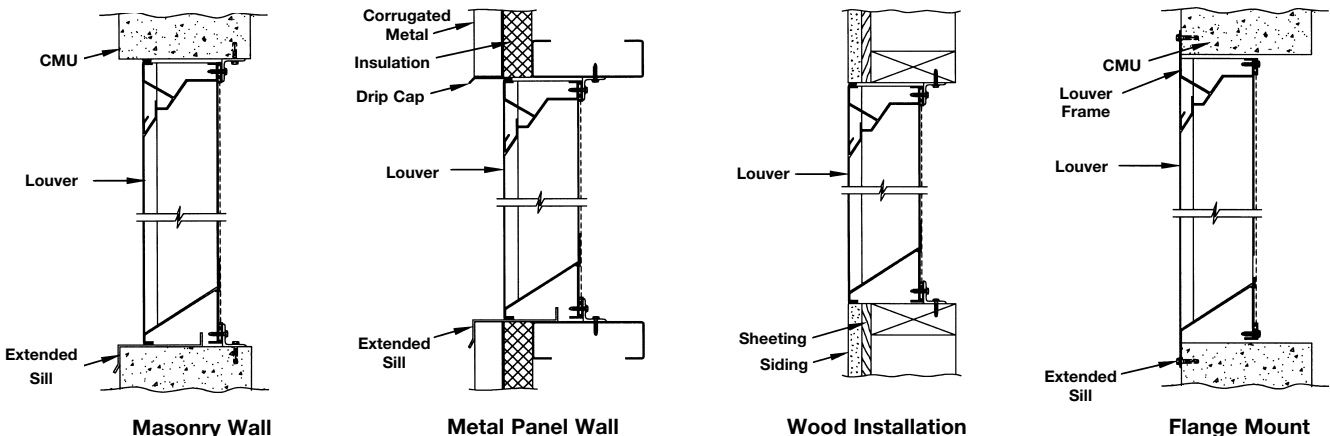

Specifications are subject to change without notice or obligation

EXTRUDED ALUMINUM LOUVERS



CSE600 High Performance Stationary 6" Deep, 37 1/2° Blade Angle

STANDARD CONSTRUCTION

FRAME

6" deep, 6063T5 extruded aluminum.
.081" nominal wall thickness. Downspouts and caulking surfaces provided.

BLADES

6063T5 extruded aluminum, .081" nominal wall thickness. Blades are positioned at 37 1/2° angle and spaced approximately 5 29/32" center to center.

SCREEN

3/4"x .051" expanded, flattened aluminum bird screen in removable frame. Screen adds approximately 1/2" to louver depth.

FINISH

Mill.

MINIMUM SIZE

12"w x 12"h

APPROXIMATE SHIPPING WEIGHT

4 lbs./ft.²

MAXIMUM FACTORY ASSEMBLY SIZE

Shall be 75 sq. ft. per section, not to exceed 120"w x 90"h or 90"w x 120"h.

Louvers larger than the maximum factory assembly size will require field assembly of smaller sections.

SUPPORTS

Louvers may be provided with rear mounted blade supports that increase overall louver depth depending on louver size, assembly configuration or windload.

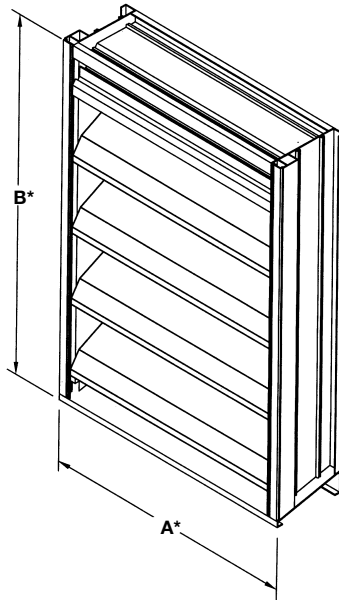

FRAME CONSTRUCTION

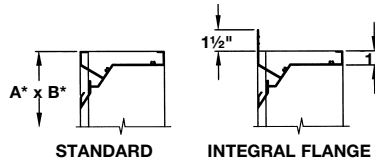

FEATURES

The CSE600 offers:

- 55% Free Area.
- Published performance ratings based on testing in accordance with AMCA Publication 511.
- High performance frame system with drainable head collects and removes water to provide excellent water penetration performance.
- Architecturally styled, hidden mullions allowing continuous line appearance up to 120".
- Aluminum construction for low maintenance and high resistance to corrosion.
- All welded construction.

PERFORMANCE DATA

AMCA Standard 500 provides a reasonable basis for testing and rating louvers. Testing to AMCA 500 is performed under a certain set of laboratory conditions. This does not guarantee that other conditions will not occur in the actual environment where louvers must operate.

The louver system should be designed with a reasonable safety factor for louver performance. To ensure protection from water carryover, design with a performance level somewhat below maximum desired pressure drop and .01 oz./sq. ft. of water penetration.

WATER PENETRATION Test size 48" wide x 48" high Beginning point of water penetration at .01 oz./sq. ft. is 803 FPM.

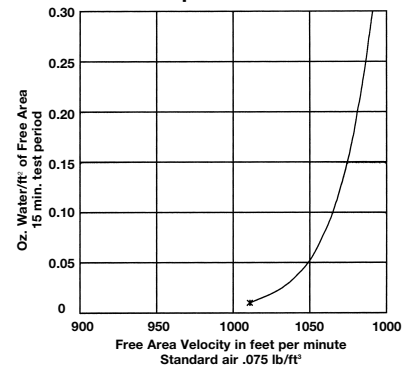

FREE AREA GUIDE

Free Area Guide shows free area in ft² and m² for various sizes of CSE600.

Height & Width - Inches and Meters	12	18	24	30	36	42	48	54	60	66	72	78	84	90	96	102	108	114	120
	0.30	0.46	0.61	0.76	0.91	1.07	1.22	1.37	1.52	1.68	1.83	1.98	2.13	2.29	2.44	2.59	2.74	2.90	3.05
12	0.31	0.50	0.69	0.88	1.07	1.26	1.45	1.63	1.81	2.01	2.20	2.39	2.58	2.77	2.96	3.15	3.34	3.49	3.71
0.30	0.03	0.05	0.06	0.08	0.10	0.12	0.13	0.15	0.17	0.19	0.20	0.22	0.24	0.26	0.28	0.29	0.31	0.32	0.34
18	0.58	0.94	1.28	1.63	1.98	2.32	2.68	3.03	3.38	3.73	4.08	4.43	4.78	5.13	5.48	5.83	6.18	6.53	6.88
0.46	0.05	0.09	0.12	0.15	0.18	0.22	0.25	0.28	0.31	0.35	0.38	0.41	0.44	0.48	.051	0.54	0.57	0.61	0.64
24	0.85	1.36	1.87	2.38	2.89	3.40	3.91	4.42	4.93	5.43	5.94	6.45	6.96	7.47	7.98	8.49	9.00	9.51	10.02
0.61	0.08	0.13	0.17	0.22	0.27	0.32	0.36	0.41	0.46	0.50	0.55	0.60	0.65	0.69	0.74	0.79	0.84	0.88	0.93
30	1.12	1.79	2.46	3.13	3.80	4.47	5.14	5.81	6.48	7.15	7.82	8.49	9.16	9.84	10.51	11.18	11.85	12.52	13.19
0.76	0.10	0.17	0.23	0.29	0.35	0.42	0.48	0.54	0.60	0.66	0.72	0.78	0.84	0.90	0.96	1.02	1.08	1.14	1.20
36	1.39	2.22	3.05	3.88	4.71	5.54	6.38	7.21	8.04	8.87	9.70	10.53	11.37	12.20	13.03	13.86	14.69	15.52	16.36
0.91	0.13	0.21	0.28	0.36	0.44	0.51	0.59	0.67	0.75	0.82	0.90	0.98	1.06	1.13	1.21	1.29	1.37	1.44	1.52
42	1.65	2.65	3.64	4.63	5.63	6.62	7.61	8.60	9.60	10.59	11.58	12.57	13.57	14.56	15.55	16.54	17.54	18.53	19.52
1.07	0.15	0.25	0.34	0.43	0.52	0.62	0.71	0.80	0.89	0.98	1.08	1.17	1.26	1.35	1.45	1.54	1.63	1.72	1.81
48	1.92	3.08	4.23	5.38	6.54	7.69	8.85	10.00	11.15	12.31	13.46	14.61	15.77	16.92	18.08	19.23	20.38	21.54	22.69
1.22	0.18	0.29	0.39	0.50	0.61	0.71	0.82	0.93	1.04	1.14	1.25	1.36	1.47	1.57	1.68	1.79	1.89	2.00	2.11
54	2.19	3.51	4.82	6.14	7.45	8.77	10.08	11.40	12.71	14.02	15.34	16.65	17.97	19.28	20.60	21.91	23.23	24.54	25.86
1.37	0.20	0.33	0.45	0.57	0.69	0.81	0.94	1.06	1.18	1.30	1.43	1.55	1.67	1.79	1.91	2.04	2.16	2.28	2.40
60	2.46	3.94	5.41	6.89	8.36	9.84	11.32	12.79	14.27	15.74	17.22	18.69	20.17	21.65	23.12	24.60	26.07	27.55	29.03
1.52	0.23	0.37	0.50	0.64	0.78	0.91	1.05	1.19	1.33	1.46	1.60	1.74	1.87	2.01	2.15	2.29	2.42	2.56	2.70
66	2.73	4.37	6.00	7.64	9.28	10.91	12.55	14.19	15.82	17.46	19.10	20.73	22.37	24.01	25.65	27.28	28.92	30.56	32.19
1.68	0.25	0.41	0.56	0.71	0.86	1.01	1.17	1.32	1.47	1.62	1.77	1.93	2.08	2.23	2.38	2.54	2.69	2.84	2.99
72	3.00	4.79	6.59	8.39	10.19	11.99	13.78	15.58	17.38	19.18	20.98	22.77	24.57	26.37	28.17	29.97	31.76	33.56	35.36
1.83	0.28	0.45	0.61	0.78	0.95	1.11	1.28	1.45	1.62	1.78	1.95	2.12	2.28	2.45	2.62	2.79	2.95	3.12	3.29
78	3.27	5.22	7.18	9.14	11.10	13.06	15.02	16.98	18.94	20.90	22.86	24.81	26.77	28.73	30.69	32.65	34.61	36.57	38.53
1.98	0.30	0.49	0.67	0.85	1.03	1.21	1.40	1.58	1.76	1.94	2.12	2.31	2.49	2.67	2.85	3.03	3.22	3.40	3.58
84	3.53	5.65	7.77	9.89	12.01	14.13	16.25	18.37	20.49	22.61	24.73	26.85	28.98	31.10	33.22	35.34	37.46	39.58	41.70
2.13	0.33	0.53	0.72	0.92	1.12	1.31	1.51	1.71	1.90	2.10	2.30	2.50	2.69	2.89	3.09	3.28	3.48	3.68	3.88
90	3.80	6.08	8.36	10.65	12.93	15.21	17.49	19.77	22.05	24.33	26.61	28.90	31.18	33.46	35.74	38.02	40.30	42.58	44.86
2.29	0.35	0.57	0.78	0.99	1.20	1.41	1.63	1.84	2.05	2.26	2.47	2.69	2.90	3.11	3.32	3.53	3.75	3.96	4.17



Unit furnished approximately 1/4" smaller than given opening dimensions.
Consult Lau for other special requirements or additional information.

VARIATIONS

Variations to the basic design of these louvers are available at additional cost.

They include:

- Extended sill.
- Hinged frame.
- Front or rear security bars.
- Filter racks.
- A variety of bird and insect screens.
- Selection of finishes: prime coat, baked enamel (modified fluoropolymer), epoxy, Pearledize, Kynar, clear and color anodize (some variation in anodize color consistency is possible).

Specifications are subject to change without notice or obligation



EXTRUDED ALUMINUM LOUVERS

CSE600D High Performance Stationary, Drainable 6" Deep, 37 1/2° Blade Angle

STANDARD CONSTRUCTION

FRAME

6" deep, 6063T5 extruded aluminum.
.081" nominal wall thickness. Downspouts and caulking surfaces provided.

BLADES

6063T5 extruded aluminum, .081" nominal wall thickness. Blades are positioned at 37 1/2° angle and spaced approximately 5 29/32" center to center.

SCREEN

3/4" x .051" expanded, flattened aluminum bird screen in removable frame. Screen adds approximately 1/2" to louver depth.

FINISH

Mill.

MINIMUM SIZE

12"w x 12"h

APPROXIMATE SHIPPING WEIGHT

4 lbs./ft.²

MAXIMUM FACTORY ASSEMBLY SIZE

Shall be 75 sq. ft. per section, not to exceed 120"w x 90"h or 90"w x 120"h.

Louvers larger than the maximum factory assembly size will require field assembly of smaller sections.

SUPPORTS

Louvers may be provided with rear mounted blade supports that increase overall louver depth depending on louver size, assembly configuration or windload.

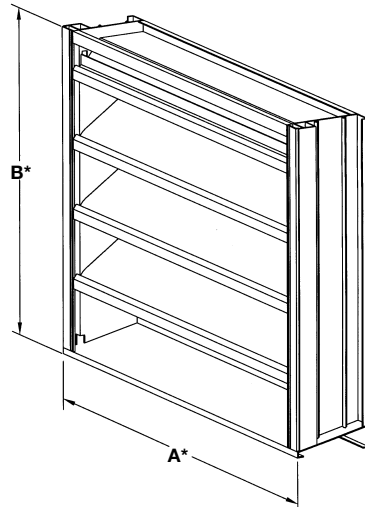

FEATURES

The CSE600D offers:

- 57% Free Area.
- Published performance ratings based on testing in accordance with AMCA Publication 511.
- High performance frame system with drainable head collects and removes water to provide excellent water penetration performance.
- Architecturally styled, hidden mullions allowing continuous line appearance up to 120".
- Aluminum construction for low maintenance and high resistance to corrosion.
- All welded construction.

PERFORMANCE DATA

AMCA Standard 500 provides a reasonable basis for testing and rating louvers. Testing to AMCA 500 is performed under a certain set of laboratory conditions. This does not guarantee that other conditions will not occur in the actual environment where louvers must operate.

The louver system should be designed with a reasonable safety factor for louver performance. To ensure protection from water carryover, design with a performance level somewhat below maximum desired pressure drop and .01 oz./sq. ft. of water penetration.

FRAME CONSTRUCTION

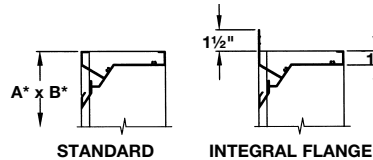

WATER PENETRATION

Test size 48" wide x 48" high
Beginning point of water penetration at
.01 oz./sq. ft. is 803 FPM.

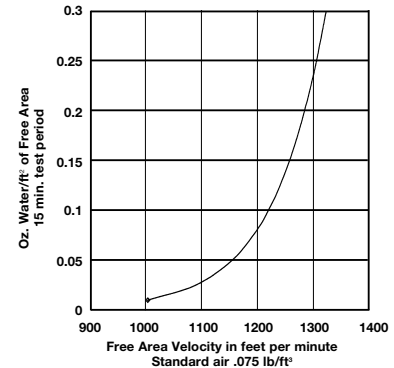

FREE AREA GUIDE

Free Area Guide shows free area in ft² and m² for various sizes of CSE600D.

Height & Width - Inches and Meters	12		18		24		30		36		42		48		54		60		66		72		78		84		90		96		102		108		114		120		
	12 0.30	18 0.46	24 0.61	30 0.76	36 0.91	42 1.07	48 1.22	54 1.37	60 1.52	66 1.68	72 1.83	78 1.98	84 2.13	90 2.29	96 2.44	102 2.59	108 2.74	114 2.90	120 3.05	12 0.30	18 0.46	24 0.61	30 0.76	36 0.91	42 1.07	48 1.22	54 1.37	60 1.52	66 1.68	72 1.83	78 1.98	84 2.13	90 2.29	96 2.44	102 2.59	108 2.74	114 2.90	120 3.05	
12	0.31	0.49	0.67	0.86	1.04	1.22	1.41	1.59	1.77	1.96	2.14	2.32	2.51	2.69	2.88	3.06	3.25	3.43	3.61	0.30	0.03	0.05	0.06	0.08	0.10	0.11	0.13	0.15	0.16	0.18	0.20	0.22	0.23	0.25	0.27	0.28	0.30	0.32	0.34
18	0.58	0.93	1.28	1.63	1.98	2.32	2.68	3.03	3.37	3.73	4.08	4.42	4.77	5.13	5.48	5.82	6.18	6.52	6.87	0.46	0.05	0.09	0.12	0.15	0.18	0.22	0.25	0.28	0.31	0.35	0.38	0.41	0.44	0.48	0.51	0.54	0.57	0.61	0.64
24	0.86	1.38	1.89	2.40	2.92	3.43	3.96	4.47	4.98	5.50	6.02	6.53	7.05	7.57	8.09	8.60	9.12	9.63	10.15	0.61	0.08	0.13	0.18	0.22	0.27	0.32	0.37	0.42	0.46	0.51	0.56	0.61	0.66	0.70	0.75	0.80	0.85	0.89	0.94
30	1.14	1.82	2.50	3.18	3.87	4.54	5.24	5.92	6.59	7.28	7.97	8.64	9.33	10.01	10.70	11.37	12.06	12.74	13.42	0.76	0.11	0.17	0.23	0.30	0.36	0.42	0.49	0.55	0.61	0.68	0.74	0.80	0.87	0.93	0.99	1.06	1.12	1.18	1.25
36	1.41	2.26	3.11	3.95	4.80	5.64	6.52	7.35	8.18	9.04	9.89	10.73	11.58	12.44	13.29	14.13	14.98	15.82	16.67	0.91	0.13	0.21	0.29	0.37	0.45	0.52	0.61	0.68	0.76	0.84	0.92	1.00	1.08	1.16	1.24	1.31	1.39	1.47	1.55
42	1.69	2.70	3.72	4.72	5.75	6.74	7.79	8.79	9.79	10.81	11.83	12.83	13.86	14.88	15.89	16.90	17.92	18.92	19.94	1.07	0.16	0.25	0.35	0.44	0.53	0.63	0.72	0.82	0.91	1.00	1.10	1.19	1.29	1.38	1.48	1.57	1.67	1.76	1.85
48	1.97	3.15	4.33	5.50	6.69	7.86	9.08	10.24	11.40	12.59	13.78	14.95	16.14	17.33	18.51	19.68	20.87	22.04	23.23	1.22	0.18	0.29	0.40	0.51	0.62	0.73	0.84	0.95	1.06	1.17	1.28	1.39	1.50	1.61	1.72	1.83	1.94	2.05	2.16
54	2.24	3.59	4.94	6.27	7.63	8.96	10.35	11.67	13.00	14.35	15.71	17.04	18.40	19.75	21.10	22.44	23.79	25.12	26.48	1.37	0.21	0.33	0.46	0.58	0.71	0.83	0.96	1.08	1.21	1.33	1.46	1.58	1.71	1.84	1.96	2.09	2.21	2.33	2.46
60	2.52	4.03	5.55	7.05	8.57	10.06	11.62	13.12	14.60	16.13	17.65	19.14	20.67	22.19	23.71	25.21	26.73	28.22	29.75	1.52	0.23	0.37	0.52	0.66	0.80	0.93	1.08	1.22	1.36	1.50	1.64	1.78	1.92	2.06	2.20	2.34	2.48	2.62	2.76
66	2.80	4.47	6.16	7.82	9.51	11.17	12.90	14.56	16.20	17.90	19.59	21.24	22.94	24.63	26.31	27.98	29.67	31.32	33.01	1.68	0.26	0.42	0.57	0.73	0.88	1.04	1.20	1.35	1.51	1.66	1.82	1.97	2.13	2.29	2.44	2.60	2.76	2.91	3.07
72	3.08	4.92	6.76	8.59	10.45	12.27	14.18	16.00	17.81	19.67	21.53	23.35	25.21	27.07	28.91	30.74	32.60	34.42	36.28	1.83	0.29	0.46	0.63	0.80	0.97	1.14	1.32	1.49	1.66	1.83	2.00	2.17	2.34	2.52	2.69	2.86	3.03	3.20	3.37
78	3.35	5.36	7.37	9.37	11.40	13.38	15.45	17.44	19.41	21.44	23.47	25.45	27.48	29.51	31.52	33.51	35.54	37.52	39.55	1.98	0.31	0.50	0.68	0.87	1.06	1.24	1.44	1.61	1.79	1.99	2.18	2.37	2.55	2.74	2.93	3.11	3.30	3.49	3.68
84	3.63	5.80	7.98	10.14	12.34	14.48	16.73	18.88	21.02	23.21	25.41	27.55	29.75	31.94	34.12	36.28	38.48	40.62	42.82	2.13	0.34	0.54	0.74	0.94	1.15	1.35	1.55	1.75	1.95	2.16	2.36	2.56	2.76	2.97	3.17	3.37	3.58	3.77	3.98
90	3.91	6.25	8.59	10.92	13.28	15.59	18.01	20.32	22.62	24.98	27.35	29.65	32.02	34.38	36.73	39.05	41.41	43.72	46.09	2.29	0.36	0.58	0.80	1.01	1.23	1.45	1.67	1.89	2.10	2.32	2.54	2.76	2.98	3.19	3.41	3.63	3.85	4.06	4.28



Unit furnished approximately 1/4" smaller than given opening dimensions.
Consult Lau for other special requirements or additional information.

Specifications are subject to change without notice or obligation

EXTRUDED ALUMINUM LOUVERS



CL600DX Combination Louver, Drainable 6" Deep, 37 1/2° Blade Angle

STANDARD CONSTRUCTION

FRAME

6" deep, 6063T5 extruded aluminum with .125" nominal wall thickness. Downspouts and caulking surfaces provided.

BLADES

Front stationary drainable blades – 6063T5 extruded aluminum with .081" nominal wall thickness, positioned at 37 1/2° angle and spaced approximately 6 1/8" on center. Rear adjustable airfoil blades – 6063T5 extruded aluminum, .140" nominal wall thickness.

SCREEN

3/4" x .051" expanded, flattened aluminum bird screen in removable frame. Screen adds approximately 1/2" to louver depth.

SEALS

Extruded vinyl blade edge seals on rear adjustable blades and flexible, compressible aluminum jamb seals.

LINKAGE

Concealed in frame.

BEARINGS

Stainless steel sleeve pressed into frame.

AXLES

1/2" plated steel hex.

ACTUATOR

Locking louver quadrant.

FINISH

Mill.

MINIMUM SIZE

12"w x 12"h

APPROXIMATE SHIPPING WEIGHT

8 lbs. per sq. ft.

MAXIMUM FACTORY ASSEMBLY SIZE

Shall be 120"w x 96"h with standard frame, 120"w x 93"h with integral flange frame. Maximum operating section width is 60".

Louvers larger than the maximum factory assembly size will require field assembly of smaller sections.

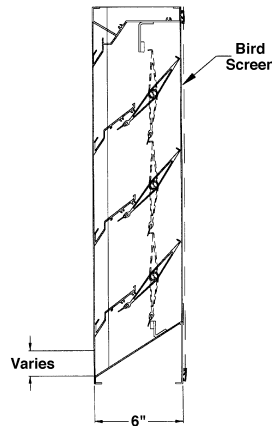
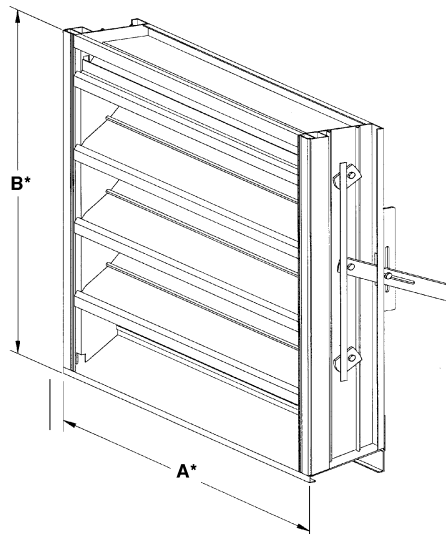

FRAME CONSTRUCTION

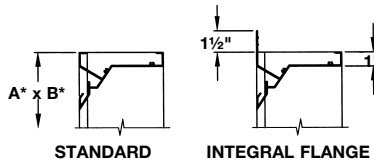

FEATURES

The CL600DX offers:

- 47% Free Area.
- Published performance ratings based on testing in accordance with AMCA Publication 511.
- Concealed blade linkage is protected from weather exposure and reduces required installation depth.
- Adjustable rear blades provide desired shut off in the same 6" deep frame normally required by a louver alone.
- Blade and jamb seals provide tight closure.
- High performance frame system with drainable head collects and removes water to provide excellent water penetration performance.
- A drain gutter in each front stationary blade minimizes water cascade between blades.
- Architecturally styled hidden mullions allowing continuous line appearance up to 120".

PERFORMANCE DATA

AMCA Standard 500 provides a reasonable basis for testing and rating louvers. Testing to AMCA 500 is performed under a certain set of laboratory conditions. This does not guarantee that other conditions will not occur in the actual environment where louvers must operate.

The louver system should be designed with a reasonable safety factor for louver performance. To ensure protection from water carry-over, design with a performance level somewhat below maximum desired pressure drop and .01 oz./sq. ft. of water penetration.

VARIATIONS

Variations to the basic design of the louver are available at additional cost. They include:

- Extended sill.
- Hinged frame.
- Front or rear security bars.
- Filter racks.
- Installation angles.
- A variety of bird and insect screens.
- A selection of manual, electric, and pneumatic actuators.
- Selection of finishes: prime coat, baked enamel (modified fluoropolymer), epoxy, Acrodize, Kynar, clear and color anodize (some variation in anodize color consistency is possible).



Unit furnished approximately 1/4" smaller than given opening dimensions. Consult Lau for other special requirements or additional information.



EXTRUDED ALUMINUM LOUVERS

CL600DX Combination Louver, Drainable 6" Deep, 37½° Blade Angle

WATER PENETRATION

Test size 48" wide x 48" high
Beginning point of water penetration
at .01 oz./sq. ft. is 1169 fpm

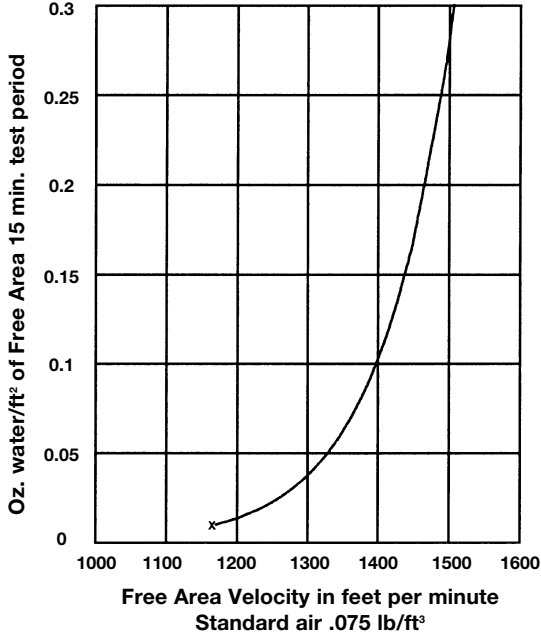

PRESSURE DROP

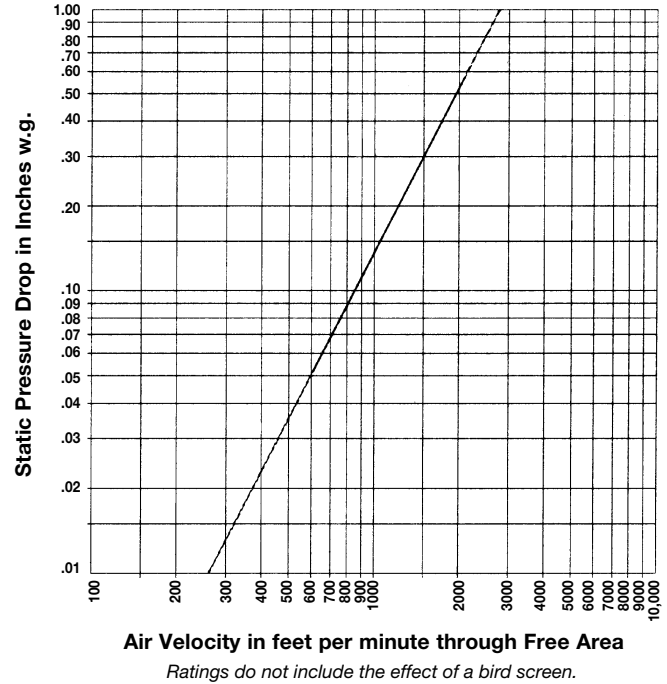

FREE AREA GUIDE

Free Area Guide shows free area in ft² and m²
for various sizes of CL600DX.
Width - Inches (Meters)

Height - Inches and Meters	Width - Inches (Meters)																			
	12	18	24	30	36	42	48	54	60	66	72	78	84	90	96	102	108	114	120	
18	0.48	0.77	1.06	1.35	1.64	1.93	2.21	2.50	2.79	2.94	3.23	3.51	3.80	4.09	4.38	4.67	4.96	5.25	5.54	
24	0.69	1.11	1.52	1.94	2.35	2.77	3.18	3.60	4.01	4.22	4.64	5.05	5.47	5.88	6.30	6.71	7.13	7.54	7.96	
30	0.93	1.48	2.04	2.59	3.15	3.70	4.26	4.81	5.37	5.64	6.20	6.75	7.31	7.86	8.42	8.97	9.53	10.09	10.64	
36	1.16	1.85	2.55	3.24	3.94	4.63	5.33	6.03	6.72	7.07	7.76	8.46	9.15	9.85	10.54	11.24	11.93	12.63	13.32	
42	1.39	2.23	3.06	3.90	4.73	5.57	6.40	7.24	8.07	8.49	9.33	10.16	11.00	11.83	12.67	13.50	14.34	15.17	16.01	
48	1.63	2.60	3.58	4.55	5.53	6.50	7.48	8.45	9.43	9.92	10.89	11.87	12.84	13.82	14.79	15.77	16.74	17.72	18.69	
54	1.86	2.97	4.09	5.21	6.32	7.44	8.55	9.67	10.78	11.34	12.46	13.57	14.69	15.80	16.92	18.03	19.15	20.26	21.38	
60	2.09	3.35	4.60	5.86	7.11	8.37	9.63	10.88	12.14	12.76	14.02	15.28	16.53	17.79	19.04	20.30	21.55	22.81	24.06	
66	2.33	3.72	5.12	6.51	7.91	9.30	10.70	12.09	13.49	14.19	15.58	16.98	18.37	19.77	21.17	22.56	23.96	25.35	26.75	
72	2.56	4.09	5.63	7.17	8.70	10.24	11.77	13.31	14.84	15.61	17.15	18.68	20.22	21.75	23.29	24.83	26.36	27.90	29.43	
78	2.79	4.47	6.14	7.82	9.50	11.17	12.85	14.52	16.20	17.04	18.71	20.39	22.06	23.74	25.41	27.09	28.77	30.44	32.12	
84	3.03	4.84	6.66	8.47	10.29	12.11	13.92	15.74	17.55	18.46	20.28	22.09	23.91	25.72	27.54	29.35	31.17	32.99	34.80	
90	3.26	5.22	7.17	9.13	11.08	13.04	14.99	16.95	18.91	19.88	21.84	23.80	25.75	27.71	29.66	31.62	33.57	35.53	37.49	
96	3.49	5.59	7.68	9.78	11.88	13.97	16.07	18.16	20.26	21.31	23.40	25.50	27.60	29.69	31.79	33.88	35.98	38.08	40.17	
102	3.72	6.02	8.24	10.48	12.76	15.04	17.32	19.60	21.88	22.99	25.26	27.54	29.82	32.10	34.38	36.66	38.94	41.22	43.50	
108	3.95	6.49	8.81	11.19	13.66	16.13	18.60	21.07	23.54	24.71	27.18	29.65	32.12	34.59	37.06	39.53	42.00	44.47	46.94	
114	4.18	6.99	9.34	11.92	14.44	17.11	19.78	22.45	25.12	26.35	28.92	31.49	34.06	36.63	39.20	41.77	44.34	46.91	49.48	
120	4.41	7.52	9.91	12.68	15.34	18.24	21.00	23.76	26.52	27.81	30.58	33.35	36.12	38.89	41.66	44.43	47.20	49.97	52.74	

AIR LEAKAGE

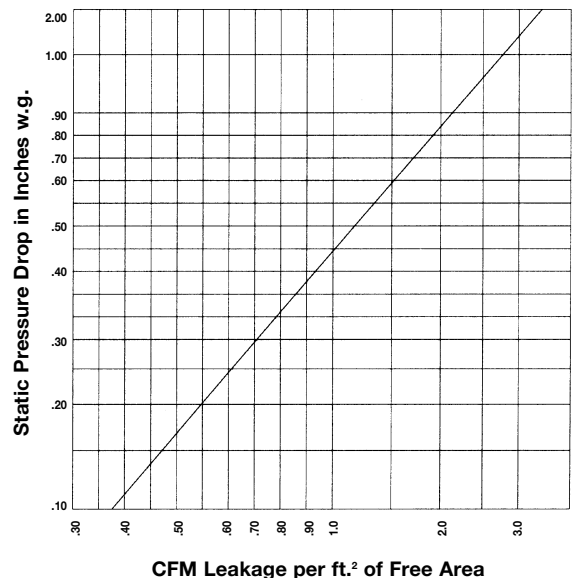

Specifications are subject to change without notice or obligation

EXTRUDED ALUMINUM LOUVERS



CL400D Combination Louver, Drainable 4" Deep, 45° Blade Angle

STANDARD CONSTRUCTION

FRAME

4" deep, 6063T5 extruded aluminum with .081" nominal wall thickness. Downspouts and caulking surfaces provided.

BLADES

Front stationary drainable blades – 6063T5 extruded aluminum with .060" nominal wall thickness, positioned at 45° angle and spaced approximately 4⁷/₈" center to center.

Rear adjustable blades – 6063T5 extruded aluminum, .125" nominal wall thickness for operating section widths through 48".

SCREEN

3/4" x .051" expanded, flattened aluminum bird screen in removable frame. Screen adds approximately 1/2" to louver depth.

SEALS

Extruded vinyl blade edge seals on rear adjustable blades and flexible, compressible aluminum jamb seals.

LINKAGE

Concealed.

BEARINGS

Stainless steel sleeve pressed into frame.

AXLES

1/2" plated steel hex.

ACTUATOR

Locking louver quadrant.

FINISH

Mill.

MINIMUM SIZE

12"w x 12"h

APPROXIMATE SHIPPING WEIGHT

6 lbs./ft.².

MAXIMUM FACTORY ASSEMBLY SIZE

Shall be 48"w x 96"h

Louvers larger than the maximum factory assembly size will require field assembly of smaller sections.

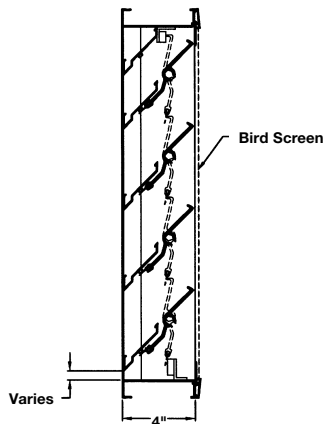
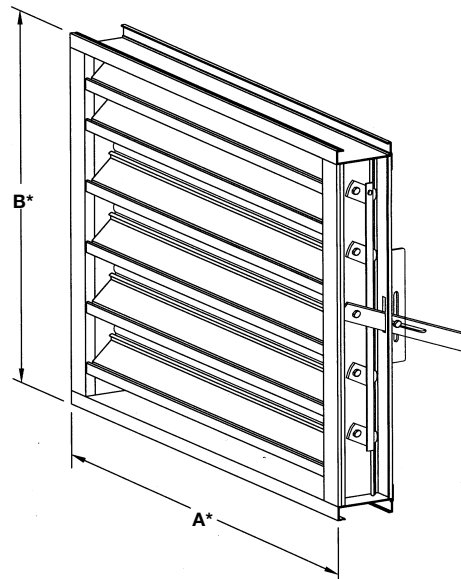

FEATURES

The CL400D offers:

- 39% Free Area.
- Published performance ratings based on testing in accordance with AMCA Publication 511.
- High free area, low water penetration, and low pressure drop.
- Concealed blade linkage is protected from weather exposure and reduces required installation depth.
- Adjustable rear blades provide desired shut off in the same 4" deep frame normally required by a louver alone.
- Blade and jamb seals provide tight closure.
- A drain gutter in each front stationary blade and downspouts in jambs and mullions drain water from the louver with minimum water cascade from blade to blade.

PERFORMANCE DATA

AMCA Standard 500 provides a reasonable basis for testing and rating louvers. Testing to AMCA 500 is performed under a certain set of laboratory conditions. This does not guarantee that other conditions will not occur in the actual environment where louvers must operate.

The louver system should be designed with a reasonable safety factor for louver performance. To ensure protection from water carry-over, design with a performance level somewhat below maximum desired pressure drop and .01 oz./sq. ft. of water penetration.

VARIATIONS

Variations to the basic design of the louver are available at additional cost. They include:

- Extended sill.
- Electric or pneumatic actuators.
- Front or rear security bars.
- Filter racks.
- A variety of bird and insect screens.
- Selection of finishes: prime coat, baked enamel (modified fluoropolymer), epoxy, Acrodize, Kynar, clear and color anodize (some variation in anodize color consistency is possible).

FRAME CONSTRUCTION

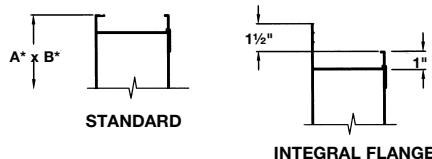

Unit furnished approximately 1/4" smaller than given opening dimensions. Consult Lau for other special requirements or additional information.

Specifications are subject to change without notice or obligation

CL400D Combination Louver, Drainable 4" Deep, 45° Blade Angle

WATER PENETRATION

Test size 48" wide x 48" high
Beginning point of water penetration
at .01 oz./sq. ft. is 974 fpm

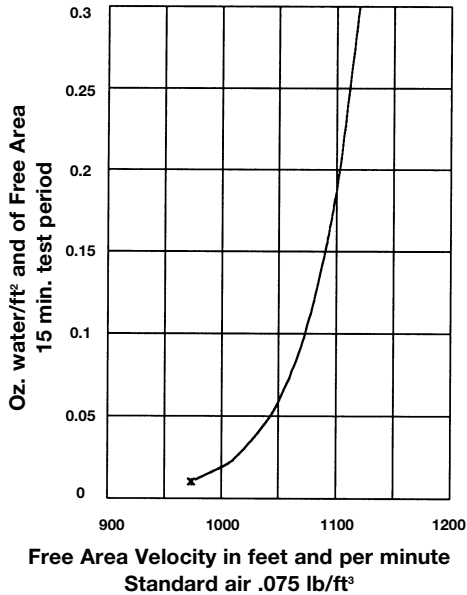

PRESSURE DROP

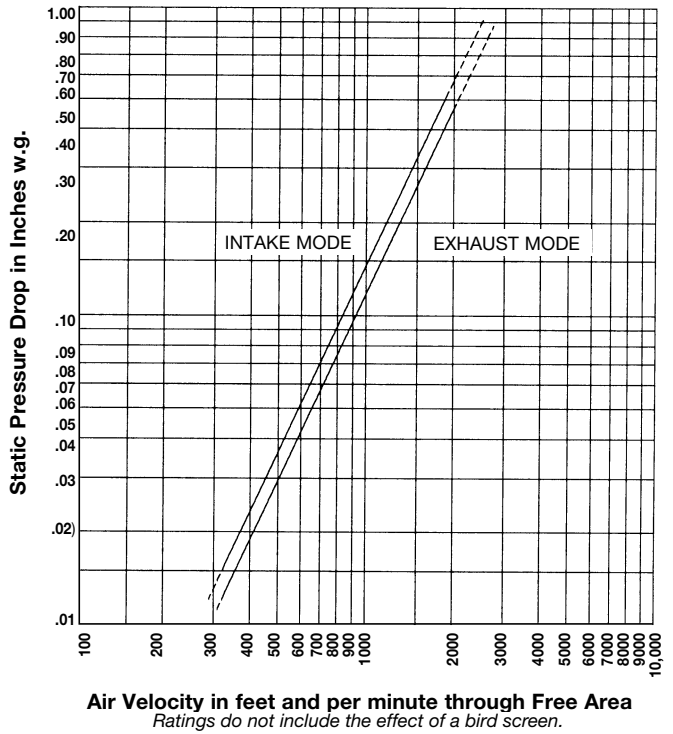

FREE AREA GUIDE

Free Area Guide shows free area in ft² and m²
for various sizes of CL400D.

Height - Inches and Meters	12	18	24	30	36	42	48
	0.30	0.30	0.46	0.61	0.76	0.91	1.07
12	0.11	0.18	0.24	0.31	0.38	0.45	0.51
0.30	0.01	0.02	0.02	0.03	0.04	0.04	0.05
18	0.40	0.64	0.89	1.13	1.38	1.63	1.87
0.46	0.04	0.06	0.08	0.11	0.13	0.15	0.17
24	0.54	0.87	1.21	1.55	1.88	2.22	2.55
0.61	0.05	0.08	0.11	0.14	0.17	0.21	0.24
30	0.75	1.22	1.69	2.15	2.62	3.09	3.56
0.76	0.07	0.11	0.16	0.20	0.24	0.29	0.33
36	0.97	1.57	2.18	2.78	3.39	3.99	4.59
0.91	0.09	0.15	0.20	0.26	0.32	0.37	0.43
42	1.11	1.81	2.50	3.19	3.89	4.58	5.27
1.07	0.10	0.17	0.23	0.30	0.36	0.43	0.49
48	1.32	2.15	2.98	3.80	4.63	5.45	6.28
1.22	0.12	0.20	0.28	0.35	0.43	0.51	0.58
54	1.54	2.50	3.47	4.43	5.39	6.35	7.31
1.37	0.14	0.23	0.32	0.41	0.50	0.59	0.68
60	1.69	2.74	3.79	4.84	5.89	6.94	7.99
1.52	0.16	0.25	0.35	0.45	0.55	0.64	0.74
66	1.90	3.08	4.26	5.45	6.63	7.81	9.00
1.68	0.18	0.29	0.40	0.51	0.62	0.73	0.84
72	2.12	3.44	4.76	6.07	7.39	8.71	10.03
1.83	0.20	0.32	0.44	0.56	0.69	0.81	0.93
78	2.26	3.67	5.08	6.49	7.90	9.30	10.71
1.98	0.21	0.34	0.47	0.60	0.73	0.86	1.00
84	2.55	4.13	5.72	7.31	8.90	10.48	12.07
2.13	0.24	0.38	0.53	0.68	0.83	0.97	1.12
90	2.69	4.37	6.04	7.72	9.40	11.08	12.75
2.29	0.25	0.41	0.56	0.72	0.87	1.03	1.18
96	2.83	4.60	6.37	8.13	9.90	11.67	13.43
2.44	0.26	0.43	0.59	0.76	0.92	1.08	1.25

AIR LEAKAGE

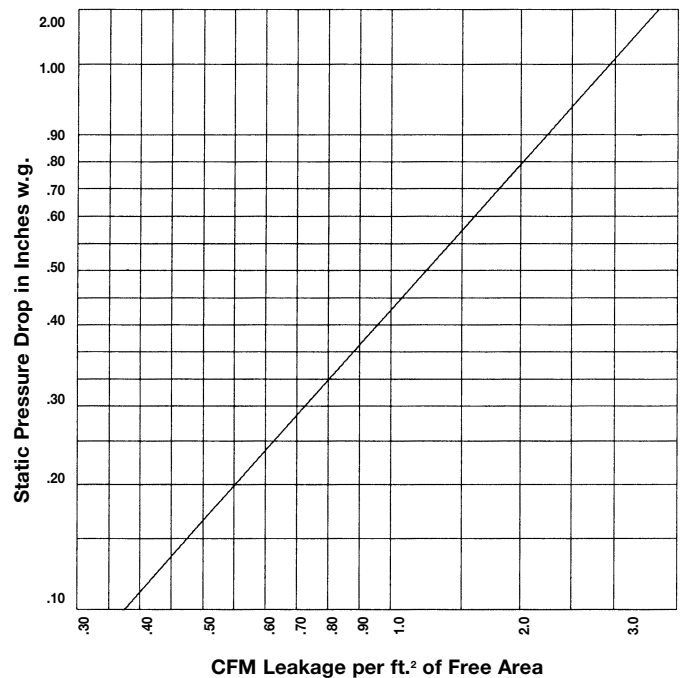

Specifications are subject to change without notice or obligation

EXTRUDED ALUMINUM LOUVERS



AL600D

Adjustable Louver, Drainable

6" Deep, 37 1/2° Blade Angle

STANDARD CONSTRUCTION

FRAME

6" deep, 6063T5 extruded aluminum with .081" nominal wall thickness. Downspouts and caulking surfaces provided.

BLADES

6063T5 extruded aluminum. .081" nominal wall thickness. Drainable blades are adjustable to 37 1/2° angle. Blade spacing is approximately 6" center to center.

SCREEN

3/4" x .051" expanded, flattened aluminum bird screen in removable frame. Screen adds approximately 1/2" to louver depth.

SEALS

Flexible, compressible aluminum jamb seals.

BEARINGS

Stainless steel sleeve pressed into frame.

AXLES

1/2" plated steel hex.

FINISH

Mill.

LINKAGE

Concealed in frame.

ACTUATOR

Locking louver quadrant.

MINIMUM SIZE

12"w x 12"h

APPROXIMATE SHIPPING WEIGHT

3.5 lbs./ ft.².

MAXIMUM FACTORY ASSEMBLY SIZE

Shall be 60"w x 96"h without seals. Louvers with standard jamb seals and/or optional blade seals shall be 48"w x 96"h. Standard construction includes jamb seals. Louvers larger than the maximum factory assembly size will require field assembly of smaller sections.

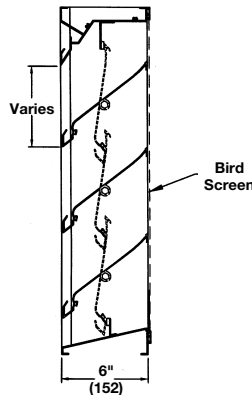
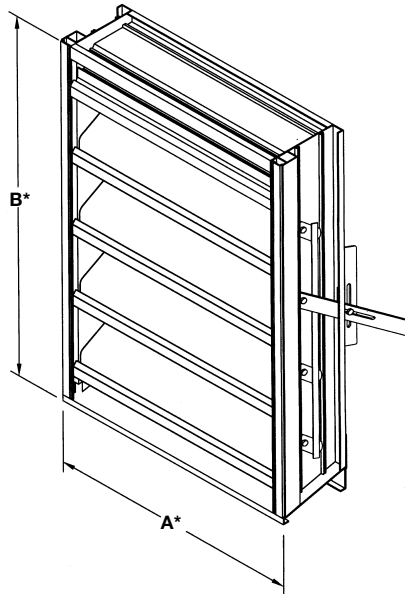

FRAME CONSTRUCTION

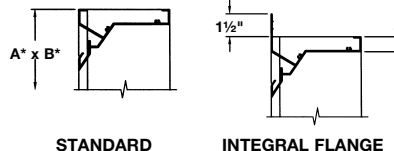

FEATURES

The AL600D offers:

- 55% Free Area.
- Published performance ratings based on testing in accordance with AMCA Publication 511.
- Low torque operation and architecturally pleasing appearance with low leakage performance.
- Drain gutter in the head frame and each blade; downspouts in jombs and mullions to drain water from louver for minimum water cascade from blade to blade.
- Concealed blade linkage is protected from weather exposure and reduces required installation depth.
- Jamb seals provide tight blade-to-frame closure.

PERFORMANCE DATA

AMCA Standard 500 provides a reasonable basis for testing and rating louvers. Testing to AMCA 500 is performed under a certain set of laboratory conditions. This does not guarantee that other conditions will not occur in the actual environment where louvers must operate.

The louver system should be designed with a reasonable safety factor for louver performance. To ensure protection from water carry-over, design with a performance level somewhat below maximum desired pressure drop and .01 oz./sq. ft. of water penetration.

VARIATIONS

Variations to the basic design of this louver are available at additional cost. They include:

- Extended sill.
- Front or rear security bars.
- Filter racks.
- Blade edge seals.
- A variety of bird and insect screens.
- Selection of finishes: prime coat, baked enamel (modified fluoropolymer), epoxy, Acrodize, Kynar, clear and color anodize (some variation in anodize color consistency is possible).
- Manual, electric or pneumatic actuators.



Unit furnished approximately 1/4" smaller than given opening dimensions. Consult Lau for other special requirements or additional information.

Specifications are subject to change without notice or obligation

AL600D Adjustable Louver, Drainable 6" Deep, 37½° Blade Angle

WATER PENETRATION

Test size 48" wide x 48" high
Beginning point of water penetration
at .01 oz./sq. ft. is 846 fpm.

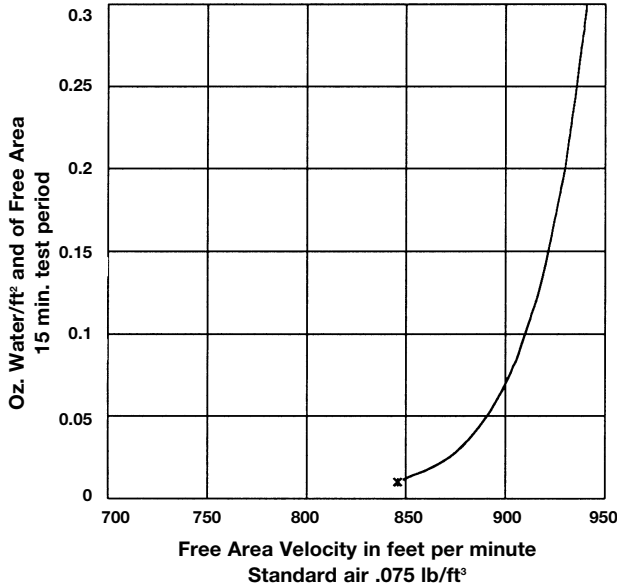

PRESSURE DROP

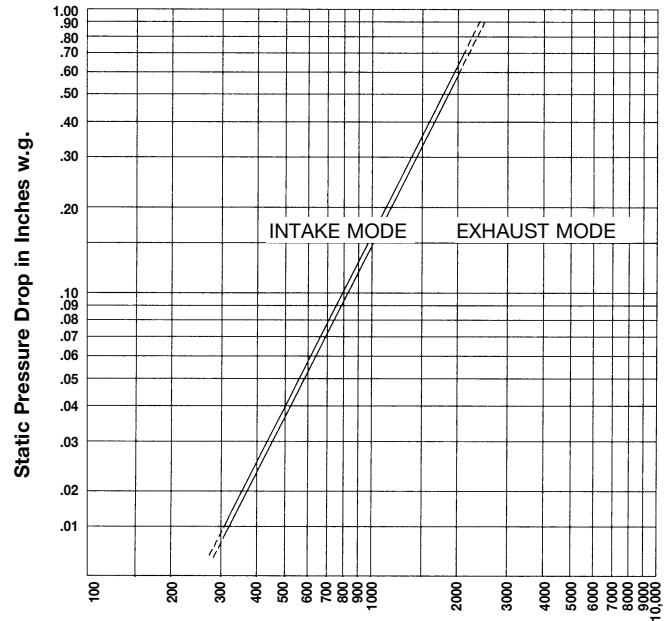

Air Velocity in feet per minute through Free Area
Ratings do not include the effect of a bird screen.

Louver tested for water penetration and pressure drop with jamb seals.

FREE AREA GUIDE

Free Area Guide shows free area in ft² and m²
for various sizes of AL600D.
Width – Inches and Meters

Height – Inches and Meters	12	18	24	30	36	42	48	54	60
	0.30	0.46	0.61	0.76	0.91	1.07	1.22	1.37	1.52
12	0.31	0.50	0.68	0.87	1.06	1.24	1.43	1.55	1.74
0.30	0.03	0.05	0.06	0.08	0.10	0.12	0.13	0.14	0.16
18	0.57	0.92	1.26	1.61	1.95	2.30	2.64	2.87	3.22
0.46	0.05	0.09	0.12	0.15	0.18	0.21	0.25	0.27	0.30
24	0.84	1.34	1.84	2.35	2.85	3.35	3.86	4.19	4.69
0.61	0.08	0.12	0.17	0.22	0.26	0.31	0.36	0.39	0.44
30	1.10	1.76	2.43	3.09	3.75	4.41	5.07	5.51	6.17
0.76	0.10	0.16	0.23	0.29	0.35	0.41	0.47	0.51	0.57
36	1.37	2.19	3.01	3.83	4.65	5.47	6.29	6.83	7.65
0.91	0.13	0.20	0.28	0.36	0.43	0.51	0.58	0.63	0.71
42	1.63	2.61	3.59	4.57	5.54	6.52	7.50	8.15	9.13
1.07	0.15	0.24	0.33	0.42	0.51	0.61	0.70	0.76	0.85
48	1.89	3.03	4.17	5.30	6.44	7.58	8.71	9.47	10.61
1.22	0.18	0.28	0.39	0.49	0.60	0.70	0.81	0.88	0.99
54	2.16	3.45	4.75	6.04	7.34	8.63	9.93	10.79	12.09
1.37	0.20	0.32	0.44	0.56	0.68	0.80	0.92	1.00	1.12
60	2.42	3.88	5.33	6.78	8.24	9.69	11.14	12.11	13.57
1.52	0.22	0.36	0.50	0.63	0.77	0.90	1.04	1.13	1.26
66	2.69	4.30	5.91	7.52	9.13	10.75	12.36	13.43	15.04
1.68	0.25	0.40	0.55	0.70	0.85	1.00	1.15	1.25	1.40
72	2.95	4.72	6.49	8.26	10.03	11.80	13.57	14.75	16.52
1.83	0.27	0.44	0.60	0.77	0.93	1.10	1.26	1.37	1.54
78	3.21	5.14	7.07	9.00	10.93	12.86	14.79	16.07	18.00
1.98	0.30	0.48	0.66	0.84	1.02	1.20	1.37	1.49	1.67
84	3.48	5.57	7.65	9.74	11.83	13.91	16.00	17.39	19.48
2.13	0.32	0.52	0.71	0.91	1.10	1.29	1.49	1.62	1.81
90	3.74	5.99	8.23	10.48	12.73	14.97	17.22	18.71	20.96
2.29	0.35	0.56	0.76	0.97	1.18	1.39	1.60	1.74	1.95
96	4.01	6.41	8.81	11.22	13.62	16.03	18.43	20.03	22.44
2.44	0.37	0.60	0.82	1.04	1.27	1.49	1.71	1.86	2.09

AIR LEAKAGE WITH BLADES CLOSED

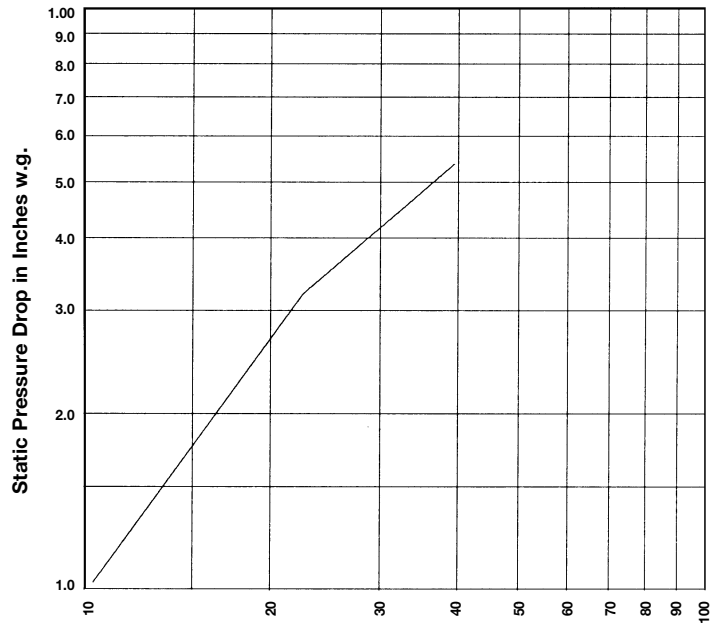

Air Velocity in feet per minute through Free Area
Leakage at 1" w.g. static pressure drop is 10.8 CFM per ft.² and (m²).
Louvers tested for air leakage with jamb seals and optional blade seals.

Specifications are subject to change without notice or obligation

General Information

AIR CURTAIN OVERVIEW

Lau Series LAD and LHAD Air Curtains can be used in a variety of locations and applications. They are designed to keep air, dirt, dust, fumes, insects, and pollen outside while maintaining a cleaner, healthier environment inside. Typical applications include fly and insect prevention at restaurant doors, thermal barriers at shopping mall entrances, and wind resistance and temperature separation at factory freight doors.

Lau Air Curtains save energy and lower building operating costs because they reduce heat loss or gain through open doors or windows while enabling traffic to flow unobstructed. They also improve energy efficiency by reducing the load on the building's HVAC system while maintaining a comfortable air temperature indoors.

WHY HAVE AN AIR CURTAIN?

Comfort - In wintertime, the air curtain reduces cold air infiltration from the outside and helps keep heated air from escaping. In summer, the curtain does the opposite, keeping cool air in while helping reduce warm air from leaking through.

Flying Insects - The high velocity air protects openings against flying insects.

Dust, Pollen, Fume & Contaminant Control - Lau Air Curtains keep airborne contaminants out of the work environment.

Safety - Air Curtains provide unobstructed visibility to an opening for customers, employees, and equipment.

Energy Efficiency - Air Curtains operate year round in all climates. In the summer, they seal in air conditioning and seal out hot air. In the winter, the opposite is true.

Cost Savings - By providing an invisible wall, energy used by Lau's Air Curtain is more than offset by the savings of the building's HVAC equipment.



Lau Air Curtains provide a powerful, uniform stream of air by sealing openings against environmental elements and contaminants.



For Baked Enamel color finishes, see Page 218.

To receive color samples, call: 937.253-2000

AIR CURTAIN TABLE OF CONTENTS

General Information	214
LAD Series	215
LHAD Series	216
Quick Reference Chart	217
LAD & LHAD Suggested Specifications	218
Baked Enamel Coatings	218

Lau LAD Air Curtains are designed to keep dirt, dust, fumes, insects, pollen, and odors outside while maintaining a cleaner, healthier environment inside.

Features

- **UL listed assembly**
- **Adjustable inlet and discharge flow**
- **15 standard colors**



Accessories & Options

- **Control Box – for manual ON/OFF control**
- **Air Filter – reusable, washable aluminum wire mesh**
- **Custom paint color (requires chip)**

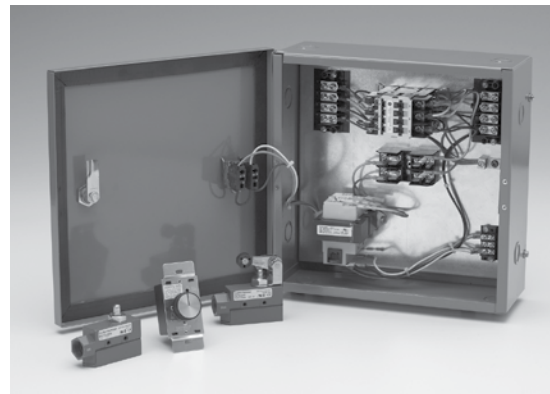

Optional control box can be used for stand-alone manual control or in conjunction with optional switches.

LAD MODEL SELECTION CHART

Unit Sizes	Unit Weight	Sound (dBA)	Motor Options	Door Height	Cabinet Color	Curtain Switches	Filter (in.)
36"	61 lbs.	60	115V/60Hz/1ph 208V/240V 60Hz/1ph 480V/60Hz/3ph	8 ft.	Choose from 15 standard colors (see Page 218) or create a custom color	Plunger Type Roller Type	F-XX
42"	65 lbs.	60					
48"	68 lbs.	60					
64"	113 lbs.	63					
78"	122 lbs.	63					
84"	126 lbs.	63					

Specifications are subject to change without notice or obligation

COMMERCIAL AIR CURTAINS

LHAD Series



With Electric Heater

Lau LHAD Air Curtains contain electric heaters (various heater ranges) providing instantaneous comfort in cold weather conditions.



**5-Year
Warranty
on Entire
Assembly**

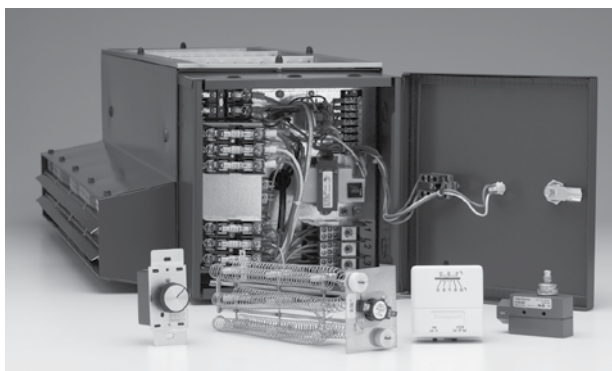

Standard control box can be mounted on the left or right hand side facing the inlet grille and controls the ON/OFF operation of the motor/blower assembly.

Features

- Standard mounted control box with thermostat control
- Factory furnished & mounted NEMA 1 control box and electric heating elements
- Remote mounted thermostat for flexibility
- UL Listed assembly
- 24 VAC heating thermostat with system and fan switches
- Adjustable inlet and discharge airflow
- 15 standard colors

Accessories & Options

- Optional plunger mounted curtain switches
- Air Filter – reusable, washable aluminum wire mesh
- Control box can be mounted on left-hand side
- Custom paint color (requires chip)

LAD MODEL SELECTION CHART

Unit Sizes	Unit Weight	Sound (dBA)	Motor Options	Door Height	Cabinet Color	Curtain Switches	Filter (in.)
36"	80 lbs.	60	240V/60Hz/1ph 208V/60Hz/1ph 480V/60Hz/3ph	8 ft.	Choose from 15 standard colors (see Page 218) or create a custom color	Plunger Type Roller Type	F-XX
42"	84 lbs.	60					
48"	87 lbs.	60					
64"	135 lbs.	63					
78"	144 lbs.	63					
84"	148 lbs.	63					

Specifications are subject to change without notice or obligation



COMMERCIAL AIR CURTAINS

LAD & LHAD Quick Reference Charts

MODEL - MOTORS, HEATERS, & CONTROL BOX DATA							
Air Curtain Model	Supply Voltage	Heater Watts (kW)	Amps Total Unit	Control Box Location*	Slave Control Box	Unit Wt. (lbs)	Sound Power (dBA)
LHAD-36	208V/60Hz/1ph	4.5, 6.8, 9	24.1, 35.2, 45.8	R (or L)	N/A	82	60
	240V/60Hz/1ph	6, 9, 12	27.5, 40, 52.5	R (or L)	N/A		
	480V/60Hz/3ph	8, 12, 16	10.4, 15.2, 20	R (or L)	N/A		
LHAD-42	208V/60Hz/1ph	4.5, 6.8, 9	24.1, 35.2, 45.8	R (or L)	N/A	86	60
	240V/60Hz/1ph	6, 9, 12	27.5, 40, 52.5	R (or L)	N/A		
	480V/60Hz/3ph	8, 12, 16	10.4, 15.2, 20	R (or L)	N/A		
LHAD-48	208V/60Hz/1ph	4.5, 6.8, 9	24.1, 35.2, 45.8	R (or L)	N/A	89	60
	240V/60Hz/1ph	6, 9, 12	27.5, 40, 52.5	R (or L)	N/A		
	480V/60Hz/3ph	8, 12, 16	10.4, 15.2, 20	R (or L)	N/A		
LHAD-64	208V/60Hz/1ph	9	48.3	R (or L)	N/A	135	63
	208V/60Hz/1ph	13.6, 18	70.4, 91.5	R (or L)	✓		
	240V/60Hz/1ph	12	55	R (or L)	N/A		
	240V/60Hz/1ph	18, 24	80, 105	R (or L)	✓		
	480V/60Hz/3ph	16, 24	20.8, 30.5	R (or L)	N/A		
	480V/60Hz/3ph	32	40.1	R (or L)	✓		
LHAD-78	208V/60Hz/1ph	9	48.3	R (or L)	N/A	144	63
	208V/60Hz/1ph	13.6, 18	70.4, 91.5	R (or L)	✓		
	240V/60Hz/1ph	12	55	R (or L)	N/A		
	240V/60Hz/1ph	18, 24	80, 105	R (or L)	✓		
	480V/60Hz/3ph	16, 24	20.8, 30.5	R (or L)	N/A		
	480V/60Hz/3ph	32	40.1	R (or L)	✓		
LHAD-84	208V/60Hz/1ph	9	48.3	R (or L)	N/A	148	63
	208V/60Hz/1ph	13.6, 18	70.4, 91.5	R (or L)	✓		
	240V/60Hz/1ph	12	55	R (or L)	N/A		
	240V/60Hz/1ph	18, 24	80, 105	R (or L)	✓		
	480V/60Hz/3ph	16, 24	20.8, 30.5	R (or L)	N/A		
	480V/60Hz/3ph	32	40.1	R (or L)	✓		

* Lau's standard control box comes factory mounted on the right side facing the inlet grille.
 ✓ Indicates that slave control box is required for proper operation. Slave control boxes ship loose.

AIR FLOW and SOUND PERFORMANCE DATA							
Model	Recommended Curtain Opening Width (mm)	Nozzle Opening (in.)	Motor (hp)	Amp Draw Full Load (115/208/480)	Airflow (cfm)	Unit Wt. (lbs)	Sound Power (dBA)
LAD-36	32" (813)	4" x 36"	1/2	5.1/2.5/0.8	1226	61	60
LAD-42	38" (965)	4" x 42"	1/2	5.1/2.5/0.8	1226	65	60
LAD-48	44" (1118)	4" x 48"	1/2	5.1/2.5/0.8	1226	68	60
LAD-64	60" (1524)	4" x 64"	(2) 1/2	10.2/5.0/1.6	2452	113	63
LAD-78	74" (1880)	4" x 78"	(2) 1/2	10.2/5.0/1.6	2452	122	63
LAD-84	80" (2032)	4" x 84"	(2) 1/2	10.2/5.0/1.6	2452	126	63

Sound tested to ANSI S12.31.

Specifications are subject to change without notice or obligation

COMMERCIAL AIR CURTAINS



LAD & LHAD Suggested Specifications

Cabinet: 20 gauge (0.9) thick painted galvanized steel.

- Baked enamel with minimum 50% Kynar finish.
- Colors must be one of Lau's 15 standard colors or as specified.

Discharge Grille: Adjustable blades made of 6063T5 aluminum extending the full length of the discharge opening.

- Securely fasten the discharge grille using 24 gauge (0.6) stainless steel clips.

Adjustable Inlet Grille: Single deflection extruded aluminum with clear anodize finish.

Factory Furnished: NEMA 1 control box, electric heating elements and thermostat.

- Mount the control box on the left or right hand side facing the inlet grille to control the ON/OFF/AUTO operation of the motor/blower assembly.

Heater Elements: Wired heating coils located in the discharge and includes a protective screen.

Motor and Blower Base: 16 gauge (1.6) galvanized steel. Either 208V/1ph/60hz multiple speed (or) 240V/1ph/60hz multiple speed (or) 480V/3ph/60hz single speed.

Thermostat with System and Fan Switches: 24 VAC remotely mounted for flexibility.

Blower: Includes forward curve (FC) double-wide, double-inlet wheel (DWDI).

Door Switches (Optional): Plunger operated (or) roller operated.

Air Filters (Optional): Reusable, washable aluminum wire mesh.

UL Listed: UL 2021 (heated) - UL 507 (unheated) **Canadian Listed:** CSA C22.2

Airflow tested in accordance with AMCA Standard 220. Sound tested in accordance with ANSI S12.51

5-year warranty on the entire air curtain assembly. Air curtains having parts-only warranty are not warranted. When submitting Air Curtain specifications, include curtain width, application, location, color, motor voltage, heater kW, and variations.

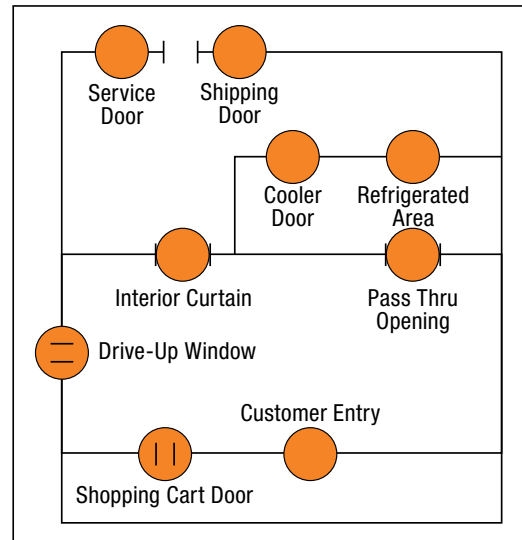

Lau Air Curtains are easy to install in hotels, manufacturing facilities, restaurants, theaters, supermarkets, hospitals, educational institutes, banks, offices, freezers, libraries and laboratories.

Baked Enamel Coatings

Lau Air Curtain finishes come in a variety of colors to blend with surrounding areas. Our finishes provide excellent weather resistance and flexibility.

Lau's High Performance Baked Enamel Finish: 50% PVDF finishes provide fluoropolymer

benefits such as long color life and resistance to chalking and chemicals.

All Lau Air Curtains receive factory applied, baked-on color coating following thorough cleaning and pretreatment of metal. Specify color name and number when ordering.

15 Standard Baked Enamel Coating Colors

Bone White (24), Ascot White (19), Herringbone (37), Dark Bronze (75), Coronado Red (34), Stone Gray (78), Shelburne (69), Portland Stone (49), Sandstone (67), Sahara Tan (65), Forest Green (36), Light Stone (43), Black (89), Taupe (52), Medium Bronze (72)

Lau can match colors in Kynar, Baked Enamel and Pearledize finishes.

The colors names above are only a sample of the thousands of colors available.

Please contact Lau for information regarding custom color matching and/or color swatches.

Specifications are subject to change without notice or obligation



APPENDIX A Propeller Performance Chart

2-Blade, Fixed Hub

Dia.	Part Number	Model Number	Rot.	Pitch	Hub Location	RPM	Static Pressure										Pk.
							0" WC		.1" WC		.2" WC		.3" WC		.4" WC		
							CFM	HP	CFM	HP	CFM	HP	CFM	HP	CFM	HP	
14"	6130470001	S08M55A1432CW	CW	32°	Discharge	825	983	.020	494	.025							2
						1075	1281	.044	929	.051	447	.061					
						1140	1359	.053	1027	.061	638	.068					
						1550	1847	.132	1605	.145	1359	.154	1094	.162	736	.178	
						1625	1937	.152	1706	.165	1472	.175	1227	.184	932	.196	
14"	6130460001	S08M55A1436CCW	CCW	36°	Intake	825	1016	.024	490	.030						2	
						1075	1324	.053	985	.061	460	.072					
						1140	1404	.064	1092	.072	628	.081					
						1550	1908	.160	1699	.172	1443	.182	1122	.191	729		.211
						1625	2001	.184	1802	.197	1565	.207	1275	.217	920		.232
14"	60743401	S02P14A1436CW	CW	36°	Discharge	825	1067	.027	689	.035						2	
						1075	1391	.061	1145	.068	742	.083					
						1140	1475	.072	1248	.080	913	.094	399	.120			
						1550	2005	.182	1850	.191	1667	.202	1442	.219	1134		.244
						1625	2102	.210	1956	.219	1785	.230	1582	.247	1321		.269
18"	6130490001	S10S08A1819CCW	CCW	19°	Intake	825	1650	.035	1075	.043						2	
						1075	2024	.081	1518	.093	1012	.100					
						1140	2147	.097	1610	.111	1073	.119	537	.121			
18"	60772501	S10CH08A1828CCW	CCW	28°	Intake	830	2003	.061	1569	.070	668	.082				2	
						1075	2572	.122	2219	.131	1799	.146	984	.160	606		.197
						1140	2768	.144	2394	.155	2093	.174	1189	.177	814		.215
18"	60652101	S10CH87A1833CCW	CCW	32°	Intake	830	2217	.078	1758	.090	748	.103				2	
						1075	2841	.154	2491	.165	2124	.189	1080	.201	707		.245
						1140	3015	.187	2667	.199	2380	.223	1310	.219	884		.268
20"	60772601	S10CH08A2028CCW	CCW	28°	Intake	830	2375	.085	1775	.095	1025	.100	400	.120		2	
						1000	2861	.148	2410	.161	1777	.168	1175	.184			
						1140	3262	.220	2850	.236	2404	.246	1827	.251			
22"	60772701	S10CH95A2216CCW	CCW	16°	Intake	830	2325	.060	1425	.070	450	.100				2	
						1000	2800	.105	2024	.110	1289	.138	452	.210			
						1140	3193	.155	2541	.158	1889	.181	1188	.218			
22"	6128990001	S10S95G2221CCW	CCW	21°	Intake	825	2950	.075	2251	.092	1401	.103				2	
						1075	3844	.166	3348	.191	2739	.204	2087	.219			
						1140	4076	.198	3614	.223	3056	.243	2441	.249	1816		.266
22"	60814201	S15E102227CCW	CCW	27°	Intake	830	3250	.095	2650	.113	1815	.130	1250	.148		2	
						1000	3910	.160	3400	.188	2890	.210	2100	.226			
						1140	4450	.240	4020	.270	3570	.298	3060	.320			
24"	61040201	S10H08A2422CCW	CCW	22°	Intake	825	3731	.100	2964	.123	1846	.137	642	.171		2	
						1075	4862	.221	4318	.255	3640	.279	2787	.295	1811		.319
						1140	5156	.264	4649	.300	4034	.327	3277	.346	2383		.365
24"	6130580001	S10S08A2424CCW	CCW	24°	Intake	825	3697	.103	2973	.120	1908	.135	911	.156	246	.183	2
						1075	4817	.228	4309	.250	3659	.270	2838	.290	1969	.313	
						1140	5108	.272	4635	.296	4049	.317	3316	.338	2486	.360	
24"	60772801	S10CH08A2427CCW	CCW	27°	Intake	830	4136	.151	3504	.175	2358	.186	899	.240		2	
						1075	5299	.300	4753	.318	4346	.360	3785	.393	1845		.416
						1140	5647	.367	5015	.370	4645	.418	4202	.460	2254		.456

Specifications are subject to change without notice or obligation

APPENDIX A

Propeller Performance Chart



3-Blade, Free Air

Dia.	Part Number	Model Number	Rot.	Pitch	Hub Location	RPM	Free Air Ratings		Pk.
							CFM	HP	
10"	60265201 60265301	T03Y10A1027CW T03Y10A1027CCW	CW CCW	27°	Inter- changeable	1050	415	0.005	2
						1140	456	0.006	
						1550	620	0.016	
						1725	690	0.022	
12"	60265401 60265501	T03R12A1223CW T03R12A1223CCW	CW CCW	23°	Inter- changeable	1050	460	0.005	2
						1140	490	0.006	
						1550	675	0.016	
						1725	750	0.022	
14"	60265801 60265901	T03R14A1423CW T03R14A1423CCW	CW CCW	23°	Inter- changeable	1050	730	0.010	2
						1140	790	0.012	
						1550	1070	0.031	
						1725	1200	0.043	
16"	60266201 60266301	T08R16A1623CW T08R16A1623CCW	CW CCW	23°	Inter- changeable	1050	1200	0.016	2
						1140	1330	0.021	
						1550	1780	0.052	
						1725	2000	0.072	
18"	60555901 60556001	T08R18A1823CW T08R18A1823CCW	CW CCW	23°	Inter- changeable	1050	1575	0.035	2
						1140	1725	0.044	
						1550	2330	0.110	
						1725	2600	0.150	
20"	60267001 60267101	T08R20A2023CW T08R20A2023CCW	CW CCW	23°	Inter- changeable	1050	2120	0.076	2
						1140	2300	0.097	
						1550	3120	0.244	
						1725	3500	0.340	
24"	60267601	T10R22A2418CW	CW	18°	Inter- changeable	1050	3300	0.102	2
						1140	3600	0.130	
						1550	4800	0.320	
						1725	5400	0.525	

4-Blade, Free Air

Dia.	Part Number	Model Number	Rot.	Pitch	Hub Location	RPM	Free Air Ratings		Pk.
							CFM	HP	
10"	60269301 60269401	F01R10A1023CW F01R10A1023CCW	CW CCW	23°	Inter- changeable	1050	298	0.003	2
						1140	322	0.005	
						1550	429	0.006	
						1725	470	0.012	
12"	60262201 60262301	F02R12A1223CW F02R12A1223CCW	CW CCW	23°	Inter- changeable	1050	460	0.006	2
						1140	500	0.007	
						1550	680	0.019	
						1725	760	0.026	
14"	60262801 60262901	F02R14A1427CW F02R14A1427CCW	CW CCW	27°	Inter- changeable	1050	880	0.021	2
						1140	960	0.027	
						1550	1300	0.068	
						1725	1450	0.095	
18"	60555301 60555401	F08R18A1823CW F08R18A1823CCW	CW CCW	23°	Inter- changeable	1050	1650	0.042	2
						1140	1780	0.054	
						1550	2425	0.135	
						1725	2700	0.185	
18"	60555501 60555601	F08R18A1827CW F08R18A1827CCW	CW CCW	27°	Inter- changeable	1050	1950	0.063	2
						1140	2110	0.087	
						1550	2875	0.220	
						1725	3170	0.300	

Specifications are subject to change without notice or obligation

4-Blade, Free Air

Dia.	Part Number	Model Number	Rot.	Pitch	Hub Location	Free Air Ratings			Pk.
						RPM	CFM	HP	
20"	60263801 60263901	F08R20A2023CW F08R20A2023CCW	CW CCW	23°	Inter-changeable	1050	2140	0.070	2
						1140	2310	0.090	
						1550	3170	0.226	
						1725	3500	0.320	
20"	60264001 60264101	F08R20A2027CW F08R20A2027CCW	CW CCW	27°	Inter-changeable	1050	2540	0.102	2
						1140	2750	0.131	
						1550	3750	0.330	
						1725	4170	0.455	
20"	60285301 60285401	F08R20A2033CW F08R20A2033CCW	CW CCW	33°	Inter-changeable	1050	2950	0.182	2
						1140	3210	0.230	
						1550	4300	0.570	
						1725	Not Recommended		
24"	60562101 60562201	F05R22A2418CW F05R22A2418CCW	CW CCW	18°	Inter-changeable	1050	3689	0.142	2
						1140	3952	0.193	
						1550	5029	0.484	
						1725	5373	0.657	
24"	60562301 60562401	F05R22A2423CW F05R22A2423CCW	CW CCW	23°	Inter-changeable	1050	3689	0.142	2
						1140	4789	0.293	
						1550	6217	0.742	
						1725	6736	1.000	
24"	60562501 60562601	F05R22A2427CW F05R22A2427CCW	CW CCW	23°	Inter-changeable	1050	5087	0.313	2
						1140	5438	0.400	
						1550	7027	0.969	
						1725	7638	1.290	

3-Blade, Heavy Duty Condenser Style

Dia.	Part Number	Model Number	Rot.	Pitch	Hub Location	RPM	0" WC		.1" WC		Static Pressure		.3" WC		.4" WC		Pk.	
							CFM	HP	CFM	HP	CFM	HP	CFM	HP	CFM	HP		
10"	6129770001 6129760001	T03Y10A1023CW T03Y10A1023CCW	CW CCW	23°	Inter-changeable	825	294	.039										2
						1075	383	.086	146	.136	64	.181	19	.222				
						1140	406	.103	173	.154	82	.205	34	.249				
						1550	552	.258	428	.306	219	.400	146	.471	99	.534		
						1625	579	.297	470	.345	251	.444	169	.522	120	.590		
10"	60265201 60265301	T02CY10A1027CW T02CY10A1027CCW	CW CCW	27°	Inter-changeable	1075	443	.013	213	.018	96	.019						2
						1140	471	.016	255	.020	115	.027						
						1550	632	.027	508	.034	335	.040	229	.048				
						1725	702	.036	593	.044	424	.050	312	.059	210	.065		
12"	60716101 60716201	T03CY12A1219CW T03CY12A1219CCW	CW CCW	19°	Inter-changeable	1075	559	.015	309	.021	169	.026						2
						1140	587	.017	378	.023	204	.028						
						1550	800	.032	674	.040	490	.047	353	.055	260	.061		
						1725	886	.042	769	.050	630	.058	455	.068	369	.076		
12"	60716301 60716401	T03CY12A1223CW T03CY12A1223CCW	CW CCW	23°	Inter-changeable	1075	720	.019	543	.027	263	.033						2
						1140	769	.022	608	.029	327	.037	162	.041				
						1550	1037	.045	936	.053	792	.064	543	.075	407	.084		
						1725	1147	.060	1064	.072	947	.082	725	.082	555	.105		
12"	6129790001 6129780001	T03R12A1227CW T03R12A1227CCW	CW CCW	27°	Inter-changeable	825	457	.009	179	.014								2
						1075	595	.020	347	.027	191	.034						
						1140	631	.024	392	.031	235	.038						
						1550	858	.060	680	.069	511	.080	390	.090	290	.100		
						1625	900	.069	731	.079	563	.089	440	.101	341	.110		

Continued on next page

Specifications are subject to change without notice or obligation

APPENDIX A

Propeller Performance Chart



3-Blade, Heavy Duty Condenser Style

Dia.	Part Number	Model Number	Rot.	Pitch	Hub Location	RPM	Static Pressure								Pk.		
							0" WC		.1" WC		.2" WC		.3" WC			.4" WC	
							CFM	HP	CFM	HP	CFM	HP	CFM	HP		CFM	HP
14"	60716501 60716601	T03CY14A1423CW T03CY14A1423CCW	CW CCW	23°	Inter-changeable	1075	1060	.031	806	.041	499	.053					2
						1140	1120	.035	893	.047	602	.058	397	.074			
						1550	1512	.071	1395	.086	1172	.102	927	.116	757	.134	
						1725	1660	.099	1566	.115	1403	.132	1141	.148	947	.167	
14"	60716701 60716801	T03CY14A1427CW T03CY14A1427CCW	CW CCW	27°	Inter-changeable	1075	1211	.037	951	.047	610	.060	338	.077			2
						1140	1275	.046	1065	.057	723	.069	485	.087			
						1550	1717	.103	1586	.117	1388	.133	1116	.149	895	.169	
						1725	1908	.134	1798	.150	1646	.166	1426	.180	1185	.199	
16"	60716901 60717001	T08Y16A1619CW T08Y16A1619CCW	CW CCW	19°	Inter-changeable	1075	1415	.046	1218	.057	774	.071	518	.085			2
						1140	1500	.053	1322	.063	962	.079	641	.093	413	.107	
						1550	2014	.111	1890	.125	1751	.142	1555	.161	1187	.181	
						1725	2212	.140	2105	.155	1988	.174	1844	.195	1620	.219	
16"	60717101 60717201	T08Y16A1623CW T08Y16A1623CCW	CW CCW	23°	Inter-changeable	1075	1613	.054	1432	.068	1080	.083	689	.101	349	.112	2
						1140	1725	.062	1556	.076	1234	.091	806	.110	562	.128	
						1550	2299	.140	2181	.158	2044	.178	1860	.200	1556	.222	
						1725	2538	.184	2438	.204	2320	.225	2170	.247	1960	.271	
16"	6129810001 6129800001	T08R16A1627CW T08R16A1627CCW	CW CCW	27°	Inter-changeable	825	1193	.025	811	.035	439	.052					2
						1075	1555	.056	1229	.064	984	.084	719	.107			
						1140	1649	.066	1334	.074	1100	.095	865	.118	502	.142	
						1550	2242	.167	1984	.170	1786	.190	1613	.217	1446	.247	
18"	60556101 60556201	T08Y18A1827CW T08Y18A1827CCW	CW CCW	27°	Inter-changeable	830	2138	.068	1741	.083	970	.097	597	.122			2
						1075	2736	.131	2489	.142	2182	.169	1464	.187	1057	.211	
						1140	2910	.155	2664	.164	2399	.192	1900	.220	1269	.237	
						1625	3957	.390	3776	.392	3595	.417	3409	.454	3189	.495	
18"	60555901 60556001	T08R18A1823CW T08R18A1823CCW	CW CCW	23°	Inter-changeable	825	1419	.031	975	.041	593	.062					2
						1075	1848	.068	1479	.077	1184	.099	895	.126	561	.152	
						1140	1960	.081	1605	.089	1322	.112	1053	.139	763	.165	
						1550	2665	.203	2382	.207	2149	.228	1939	.258	1738	.292	
18"	60556301 60556401	T08Y18A1830CW T08Y18A1830CCW	CW CCW	30°	Inter-changeable	825	2236	.080	1820	.093	1028	.110	640	.138			2
						1075	2908	.164	2596	.166	2256	.199	1582	.220	1136	.244	
						1140	3066	.189	2804	.195	2524	.226	2022	.257	1351	.274	
						1625	4370	.548	4192	.540	4003	.564	3817	.605	3612	.652	
18"	60556501 60556601	T08Y18A1833CW T08Y18A1833CCW	CW CCW	33°	Inter-changeable	825	2453	.095	2032	.105	1209	.122	746	.149			2
						1075	3127	.197	2857	.193	2534	.223	1802	.249	1252	.271	
						1140	3321	.229	3063	.229	2765	.259	2174	.292	1483	.306	
						1625	4588	.570	4448	.583	4292	.605	4109	.637	3882	.676	
20"	6129830001 6129820001	T08R20A2024CW T08R20A2024CCW	CW CCW	24°	Intake	825	1700	.038	1268	.051	938	.074					2
						1075	2215	.084	1849	.096	1574	.122	1324	.152	1051	.182	
						1140	2349	.100	1998	.111	1730	.138	1492	.169	1250	.201	
						1550	3194	.252	2915	.258	2683	.284	2482	.319	2298	.359	
20"	60556701	T08Y20A2027CW	CW	27°	Inter-changeable	850	2500	.072	2100	.085	1460	.105	950	.122			2
						1000	2970	.115	2600	.135	2170	.155	1600	.175			
						1140	3360	.170	3070	.200	2700	.230	2280	.250			
20"	60557101 60557201	T08Y20A2033CW T08Y20A2033CCW	CW CCW	33°	Inter-changeable	850	2950	.110	2570	.120	1850	.140	1300	.170			2
						1000	3500	.175	3170	.190	2550	.217	2000	.240			
						1140	4000	.250	3700	.270	3400	.300	2860	.350			

Specifications are subject to change without notice or obligation

3-Blade, Heavy Duty Condenser Style

Dia.	Part Number	Model Number	Rot.	Pitch	Hub Location	RPM	Static Pressure										Pk.
							0" WC		.1" WC		.2" WC		.3" WC		.4" WC		
							CFM	HP	CFM	HP	CFM	HP	CFM	HP	CFM	HP	
22"	60557301 60557401	T12E10A2227CW T12E10A2227CCW	CW CCW	27°	Inter-changeable	850	3930	.200	3650	.220	3200	.240	2500	.275			2
						1000	4700	.340	4400	.360	4050	.380	3600	.400			
						1140	5330	.500	5100	.530	4800	.570	4500	.620			
22"	6129850001 6129840001	T12E10A2230CW T12E10C2230CCW	CW CCW	30°	Inter-changeable	825	4135	.222	3801	.247	3352	.268	2689	.288	1897	.315	2
						1075	5388	.491	5145	.525	4862	.555	4523	.583	4100	.609	
						1140	5714	.586	5486	.621	5227	.654	4924	.684	4560	.712	
						1550	7769	1.472	7606	1.522	7432	1.569	7245	1.614	7044	1.657	
22"	60557501 60557601	T12E10A2233CW T12E10A2233CCW	CW CCW	33°	Inter-changeable	850	4600	.300	4250	.330	3800	.360	3100	.380			2
						1000	5450	.490	5150	.510	4800	.522	4380	.553			
						1140	6200	.720	5950	.753	5600	.810	5300	.850			
						825	4642	.312	4092	.340	3849	.348	3464	.360	2227	.401	
22"	6129870001 6129860001	T12E10A2235CW T12E10A2235CCW	CW CCW	35°	Inter-changeable	1075	6048	.690	5460	.742	5278	.755	5094	.766	4880	.777	2
						1140	6414	.823	5813	.884	5640	.897	5469	.909	5282	.921	
						1550	8721	2.069	8022	2.202	7883	2.224	7754	2.243	7630	2.260	
						1625	9143	2.384	8425	2.535	8289	2.558	8166	2.579	8046	2.597	
24"	6131430001	T10S08A2422	CW	22°	Intake	825	3682	.116	3260	.138	2498	.157	1553	.178			2
						1075	4798	.257	4505	.286	4117	.313	3548	.338	2780	.360	
						1140	5088	.306	4815	.338	4470	.366	3992	.394	3318	.419	
24"	60557701 60557801	T12E10A2427CW T12E10A2427CCW	CW CCW	27°	Inter-changeable	825	4844	.237	4302	.241	3855	.286	1819	.315	1247	.384	2
						1075	6277	.492	5834	.492	5518	.537	5195	.590	4769	.643	
						1140	6632	.583	6170	.584	5872	.633	5588	.688	5267	.742	
						1625	9151	1.533	8669	1.481	8427	1.536	8229	1.605	8049	1.679	
24"	60557901 60558001	T12E10A2433CW T12E10A2433CCW	CW CCW	33°	Inter-changeable	825	5335	.300	4708	.307	4244	.364	1931	.395	1444	.472	2
						1075	6956	.640	6432	.635	6092	.688	5758	.747	5346	.803	
						1140	7538	.747	6889	.725	6550	.780	6233	.848	5877	.919	
						1625	10072	1.857	9698	1.885	9421	1.949	9194	2.017	8985	2.087	
26"	61046601	T10S08A2626CW	CW	26°	Discharge	825	5115	.199	4528	.230	3569	.255	2717	.275			2
						1075	6665	.440	6225	.484	5733	.518	4968	.553	4261	.578	
						1140	7068	.525	6651	.573	6212	.609	3575	.645	4811	.677	
26"	6129890001 6129880001	T10E10A2626CW T10E10A2626CCW	CW CCW	26°	Inter-changeable	825	5600	.275	5154	.315	4648	.360	3999	.389	3133	.465	2
						1075	7297	.608	6958	.651	6607	.718	6222	.779	5782	.820	
						1140	7738	.726	7419	.769	7091	.838	6739	.907	6347	.959	
26"	6129910001 6129900001	T10E10A2633CW T10E10A2633CCW	CW CCW	33°	Inter-changeable	825	6800	.450	6419	.484	5916	.528	5325	.583	4174	.664	2
						1075	8860	.996	8595	1.041	8254	1.086	7867	1.143	7459	1.211	
						1140	9396	1.187	9150	1.235	8839	1.283	8482	1.339	8105	1.408	
26"	6130660001	T10S08A2637CW	CW	37°	Intake	825	6798	.421	6156	.433	5266	.462	4270	.499	3247	.553	2
						1075	8859	.932	8408	.941	7834	.967	7151	1.006	6410	1.050	
						1140	9394	1.112	8976	1.120	8454	1.145	7833	1.183	7150	1.228	
30"	6129930001 6129920001	T12E06A3027CW T12E06A3027CCW	CW CCW	27°	Inter-changeable	825	8871	.482	8002	.540	6844	.570	5148	.577	3565	.618	2
						1075	11559	1.066	10922	1.150	10195	1.211	9322	1.251	8215	1.268	
						1140	12258	1.272	11663	1.361	10993	1.431	10216	1.479	9270	1.506	
30"	6129950001 6129940001	T12E06A3033CW T12E06A3033CCW	CW CCW	33°	Inter-changeable	825	9775	.740	8854	.779	7613	.797	6126	.821	4668	.848	2
						1075	12737	1.637	12075	1.696	11282	1.732	10335	1.755	9250	1.779	
						1140	13507	1.953	12889	2.017	12164	2.058	11312	2.084	10334	2.108	

Interchangeable hubs for all 3, 4 and 5-Blade propellers can be ordered separately.

Specifications are subject to change without notice or obligation

APPENDIX A

Propeller Performance Chart



4-Blade, Heavy Duty Condenser Style

Dia.	Part Number	Model Number	Rot.	Pitch	Hub Location	RPM	Static Pressure								Pk.		
							0" WC		.1" WC		.2" WC		.3" WC			.4" WC	
							CFM	HP	CFM	HP	CFM	HP	CFM	HP		CFM	HP
10"	6129970001 6129960001	F02Y10A1016CW F02Y10A1016CCW	CW CCW	16°	Inter-changeable	825	359	.010	238	.014	145	.022					2
						1075	468	.023	375	.029	284	.034	213	.043	157	.057	
						1140	496	.028	409	.034	321	.038	249	.047	191	.060	
						1550	675	.070	612	.079	546	.086	480	.091	419	.099	
						1625	708	.080	648	.090	585	.097	521	.103	461	.111	
10"	60717301 60717401	F02Y10A1019CW F02Y10A1019CCW	CW CCW	19°	Inter-changeable	825	432	.012	309	.017						2	
						1075	563	.027	477	.033	361	.038					
						1140	597	.033	516	.039	416	.044					
						1550	812	.082	754	.091	692	.099	623	.107	536		.113
						1625	851	.095	796	.104	738	.113	674	.121	598		.128
10"	60717501 60717601	F02Y10A1023CW F02Y10A1023CCW	CW CCW	23°	Inter-changeable	1075	402	.012	220	.017	132	.023				2	
						1140	429	.016	271	.021	154	.026					
						1550	580	.025	479	.032	333	.038	252	.046	193		.054
						1725	646	.033	557	.041	422	.047	330	.056	277		.064
10"	60717701 60717801	F02Y10A1027CW F02Y10A1027CCW	CW CCW	27°	Inter-changeable	1140	580	.011	366	.023	209	.018				2	
						1550	788	.027	600	.029	440	.033	350	.040			
						1725	877	.037	723	.039	587	.042	462	.049			
10"	60759901 60760001	F02Y10A1033CW F02Y10A1033CCW	CW CCW	33°	Inter-changeable	1075	535	.019	334							2	
						1140	564	.022	365	.027	231	.035					
						1550	771	.045	635	.050	497	.058	398	.069			
						1725	856	.057	771	.064	607	.069	519	.080	437		.092
12"	60717901 60718001	F02Y12A1219CW F02Y12A1219CCW	CW CCW	19°	Inter-changeable	1075	586	.019	410	.025	273	.031	168	.035		2	
						1140	623	.020	471	.027	318	.033	228	.039			
						1550	839	.042	746	.051	613	.060	495	.069	415		.077
						1725	929	.054	841	.064	725	.074	612	.085	527		.094
12"	60718101 60718201	F02Y12A1223CW F02Y12A1223CCW	CW CCW	23°	Inter-changeable	1075	731	.022	569	.029	345	.037	228	.044		2	
						1140	773	.024	640	.033	414	.042	290	.049			
						1550	1045	.048	969	.061	824	.074	644	.086	534		.095
						1725	1162	.065	1095	.088	994	.089	831	.105	690		.117
12"	60718301 60718401	F02Y12A1227CW F02Y12A1227CCW	CW CCW	27°	Inter-changeable	1075	822	.023	683	.032	422	.040	272	.048		2	
						1140	872	.030	725	.039	489	.048	341	.057			
						1550	1171	.060	1100	.071	983	.084	762	.100	610		.122
						1725	1302	.081	1233	.092	1136	.107	973	.124	794		.139
12"	60760101 60760201	F02Y12A1233CW F02Y12A1233CCW	CW CCW	33°	Inter-changeable	1075	953	.032	808	.041	488	.052	326	.062		2	
						1140	1015	.040	902	.047	565	.060	408	.071			
						1550	1369	.087	1292	.096	1161	.110	919	.129	745		.144
						1725	1508	.119	1447	.127	1356	.140	1172	.163	943		.184
14"	6130010001 6130000001	F02Y14A1416CW F02Y14A1416CCW	CW CCW	16°	Inter-changeable	825	633	.008	435	.010	332	.010	278	.017	240	.028	2
						1075	825	.017	670	.022	533	.022	456	.022	404	.027	
						1140	875	.020	730	.025	591	.027	506	.025	451	.029	
						1550	1190	.050	1090	.055	975	.065	865	.070	780	.068	
						1625	1248	.058	1153	.059	1044	.072	936	.080	847	.079	
14"	60718501 60718601	F02Y14A1419CW F02Y14A1419CCW	CW CCW	19°	Inter-changeable	1075	970	.023	772	.035	492	.045	344	.055		2	
						1140	1030	.029	853	.040	576	.050	413	.063	264		.073
						1550	1380	.066	1281	.080	1134	.095	899	.108	731		.123
						1725	1523	.088	1445	.104	1332	.119	1134	.133	926		.149
14"	60718701 60718801	F02Y14A1423CW F02Y14A1423CCW	CW CCW	23°	Inter-changeable	1075	1142	.035	982	.047	628	.059	448	.072	252	.081	2
						1140	1216	.043	1075	.054	741	.069	535	.081	386	.093	
						1550	1643	.089	1564	.103	1452	.119	1248	.136	972	.154	
						1725	1810	.123	1740	.139	1644	.155	1488	.171	1211	.190	

Specifications are subject to change without notice or obligation

4-Blade, Heavy Duty Condenser Style

Dia.	Part Number	Model Number	Rot.	Pitch	Hub Location	RPM	Static Pressure								Pk.		
							0" WC		.1" WC		.2" WC		.3" WC			.4" WC	
							CFM	HP	CFM	HP	CFM	HP	CFM	HP		CFM	HP
14"	60718901 60719001	F02Y14A1427CW F02Y14A1427CCW	CW CCW	27°	Inter-changeable	1075	1286	.046	1131	.055	737	.071	525	.087		2	
						1140	1370	.054	1225	.064	843	.081	624	.096	440		.113
						1550	1838	.125	1754	.138	1629	.153	1376	.173	1090		.198
						1725	2036	.167	1963	.180	1863	.197	1702	.218	1418		.244
14"	60760301 60760401	F02Y14A1433CW F02Y14A1433CCW	CW CCW	33°	Inter-changeable	1075	1448	.061	1241	.069	858	.089	596	.105		2	
						1140	1531	.076	1341	.085	940	.108	709	.125	517		.143
						1550	2077	.179	1972	.185	1811	.200	1521	.228	1240		.255
						1725	2298	.234	2208	.245	2086	.260	1891	.282	1598		.312
16"	60719101 60719201	F08Y16A1619CW F08Y16A1619CCW	CW CCW	19°	Inter-changeable	1075	1405	.045	1231	.059	919	.075	646	.089	490	.102	2
						1140	1482	.049	1332	.065	1098	.079	766	.093	562	.109	
						1550	1960	.113	1864	.131	1740	.151	1564	.171	1324	.192	
						1725	2161	.142	2077	.166	1975	.189	1841	.213	1657	.235	
16"	60719301 60719401	F08Y16A1623CW F08Y16A1623CCW	CW CCW	23°	Inter-changeable	1075	1671	.064	1527	.078	1251	.096	845	.113	637	.133	2
						1140	1774	.072	1638	.087	1410	.107	1018	.126	784	.144	
						1550	2365	.169	2268	.189	2156	.210	2016	.233	1815	.258	
						1725	2602	.218	2518	.239	2422	.263	2307	.290	2158	.321	
16"	60719501 60719601	F08Y16A1627CW F08Y16A1627CCW	CW CCW	27°	Inter-changeable	1075	1896	.087	1747	.099	1498	.120	1018	.140	754	.158	2
						1140	1997	.100	1872	.115	1653	.133	1237	.154	934	.175	
						1550	2677	.229	2593	.244	2488	.263	2348	.288	2123	.319	
						1725	2959	.314	2879	.327	2789	.346	2682	.369	2547	.397	
16"	60760501 60760601	F08Y16A1633CW F08Y16A1633CCW	CW CCW	33°	Inter-changeable	1075	2013	.110	1852	.119	1469	.139	1123	.164	873	.188	2
						1140	2134	.123	1963	.131	1611	.154	1277	.183	1038	.209	
						1550	2882	.299	2782	.308	2655	.327	2501	.355	2296	.390	
						1725	3201	.397	3107	.405	2988	.422	2851	.449	2684	.483	
18"	6130030001 6130020001	F08Y18A1816CW F08Y18A1816CCW	CW CCW	16°	Inter-changeable	825	2011	.052	1749	.068	1215	.087	893	.105	711	.122	2
						1075	2620	.115	2448	.136	2184	.158	1748	.183	1394	.207	
						1140	2779	.137	2619	.159	2391	.182	2021	.208	1619	.235	
						1550	3778	.345	3669	.374	3540	.404	3384	.435	3185	.468	
18"	6130050001 6130040001	F08Y18A1819CW F08Y18A1819CCW	CW CCW	19°	Inter-changeable	825	1630	.030	1478	.036	980	.055	629	.069	471	.061	2
						1075	2124	.065	2022	.075	1872	.083	1543	.099	1039	.144	
						1140	2252	.078	2159	.088	2028	.096	1801	.108	1267	.154	
						1550	3062	.196	2999	.210	2923	.222	2832	.234	2720	.246	
18"	60800201 60800301	F08Y18A1823CW F08Y18A1823CCW	CW CCW	23°	Inter-changeable	825	1918	.053	1678	.068	1027	.085	663	.103		2	
						1075	2491	.105	2291	.121	2060	.147	1595	.173	1117		.190
						1140	2614	.126	2450	.142	2252	.168	1900	.199	1325		.217
						1625	3624	.319	3508	.335	3388	.361	3259	.393	3111		.431
18"	60558101 60558201	F08Y18A1827CW F08Y18A1827CCW	CW CCW	27°	Inter-changeable	825	2115	.068	1855	.082	1205	.102	765	.124		2	
						1075	2690	.136	2502	.157	2240	.188	1657	.216	1212		.236
						1140	2873	.167	2702	.179	2495	.205	2174	.239	1465		.263
						1625	3960	.408	3855	.426	3740	.451	3609	.484	3454		.523
18"	60558301 60558401	F08Y18A1830CW F08Y18A1830CCW	CW CCW	30°	Inter-changeable	825	2241	.078	1942	.093	1244	.114	799	.138		2	
						1075	2886	.172	2699	.179	2461	.204	1954	.238	1289		.259
						1140	3045	.194	2869	.206	2654	.234	2295	.270	1521		.290
						1625	4231	.487	4122	.503	4003	.529	3873	.563	3727		.603
					1725	4491	.583	4389	.599	4278	.625	4160	.659	4029	.699		



Interchangeable hubs for all 3, 4 and 5-Blade propellers can be ordered separately.

Continued on next page

Specifications are subject to change without notice or obligation

APPENDIX A

Propeller Performance Chart



4-Blade, Heavy Duty Condenser Style

Dia.	Part Number	Model Number	Rot.	Pitch	Hub Location	RPM	Static Pressure										Pk.
							0" WC		.1" WC		.2" WC		.3" WC		.4" WC		
							CFM	HP	CFM	HP	CFM	HP	CFM	HP	CFM	HP	
18"	60558501 60558601	F08Y18A1833CW F08Y18A1833CCW	CW CCW	33°	Inter-changeable	825	2433	.100	2055	.113	1391	.135	862	.157			2
						1075	3130	.208	2934	.214	2648	.240	2047	.274	1513	.297	
						1140	3309	.247	3089	.242	2828	.272	2458	.316	1750	.340	
						1625	4623	.638	4501	.634	4350	.650	4188	.683	4001	.730	
						1725	4907	.763	4796	.758	4655	.771	4506	.802	4341	.846	
20"	6130070001 6130060001	F08Y20A2014CW F08Y20A2014CCW	CW CCW	14°	Inter-changeable	825	1775	.009	1351	.024	996	.045	596	.059			2
						1075	2313	.020	1960	.036	1678	.062	1407	.089	1124	.113	
						1140	2452	.054	2115	.040	1844	.067	1588	.096	1328	.123	
						1550	3335	.061	3065	.076	2843	.105	2642	.141	2450	.180	
20"	6130090001 6130080001	F08Y20A2017CW F08Y20A2017CCW	CW CCW	17°	Inter-changeable	825	1925	.029	1475	.040	1130	.061	792	.078	329	.077	2
						1075	2508	.064	2134	.073	1837	.096	1573	.123	1319	.149	
						1140	2660	.077	2301	.085	2014	.108	1759	.136	1518	.165	
						1550	3617	.193	3335	.196	3094	.217	2879	.248	2680	.283	
20"	6130110001 6130100001	F08Y20A2019CW F08Y20A2019CCW	CW CCW	19°	Inter-changeable	825	2050	.048	1574	.057	1215	.073	881	.090	500	.099	2
						1075	2671	.106	2276	.114	1962	.131	1687	.153	1429	.175	
						1140	2833	.126	2454	.134	2150	.151	1883	.173	1635	.197	
						1550	3851	.318	3555	.323	3300	.339	3071	.361	2861	.386	
20"	60558701 60558801	F08Y20A2029CW F08Y20A2027CCW	CW CCW	27°	Inter-changeable	850	2590	.090	2180	.103	1700	.130	1300	.142			2
						1000	3000	.150	2680	.162	2300	.180	1900	.200			
						1140	3420	.196	3120	.230	2800	.255	2450	.280			
20"	60558901 60559001	F08Y20A2030CW F08Y20A2030CCW	CW CCW	30°	Inter-changeable	850	2800	.110	2490	.128	1900	.145	1500	.170			2
						1000	3300	.180	3020	.200	2650	.220	2150	.240			
						1140	3770	.260	3510	.290	3215	.310	2830	.335			
20"	60559101 60559201	F08Y20A2033CW F08Y20A2033CCW	CW CCW	33°	Inter-changeable	850	3120	.130	2700	.150	2040	.165	1610	.195			2
						1000	3660	.210	3330	.235	2850	.260	2300	.282			
						1140	4160	.315	3900	.340	3520	.360	3020	.390			
22"	60804101 60804201	F05E10A2223CW F05E10A2223CCW	CW CCW	23°	Inter-changeable	850	3300	.150	3070	.175	2760	.200	2340	.220			2
						1000	3870	.245	3700	.275	3450	.305	3150	.330			
						1140	4410	.360	4270	.395	4090	.430	3850	.460			
22"	60559301 60559401	F05E10A2223CW F05E10A2227CCW	CW CCW	27°	Inter-changeable	850	3900	.208	3650	.230	3280	.255	2800	.280			2
						1000	4580	.330	4400	.365	4100	.395	3780	.427			
						1140	5220	.500	5050	.520	4840	.565	4580	.600			
22"	60558301 60558401	F08Y18A1830CW F08Y18A1830CCW	CW CCW	30°	Inter-changeable	825	2241	.078	1942	.093	1244	.114	799	.138			2
						1075	2886	.172	2699	.179	2461	.204	1954	.238	1289	.259	
						1140	3045	.194	2869	.206	2654	.234	2295	.270	1521	.290	
						1625	4231	.487	4122	.503	4003	.529	3873	.563	3727	.603	
22"	60559501 60559601	F05E10A2233CW F05E10A2233CCW	CW CCW	33°	Inter-changeable	850	4460	.300	4200	.322	3830	.350	3100	.375			2
						1000	5250	.480	5050	.520	4780	.552	4400	.580			
						1140	6000	.710	5800	.760	5600	.800	5320	.830			
22"	6130130001 6130120001	F05E10A2235CW F05E10A2235CCW	CW CCW	35°	Inter-changeable	825	4839	.300	4549	.319	4164	.344	3525	.395	2540	.480	2
						1075	6306	.665	6093	.689	5849	.714	5559	.746	5189	.789	
						1140	6687	.793	6488	.818	6264	.845	6005	.876	5691	.915	
						1550	9092	1.992	8949	2.027	8797	2.062	8636	2.098	8463	2.135	
						1625	9532	2.296	9396	2.332	9253	2.368	9101	2.406	8939	2.445	
24"	6130150001 6130140001	F05E10A2413CW F05E10A2413CCW	CW CCW	13°	Inter-changeable	825	2631	.110	2312	.126	1889	.143	1506	.143	1231	.175	2
						1075	3428	.244	3203	.264	2921	.286	2594	.307	2267	.329	
						1140	3635	.291	3426	.312	3169	.335	2869	.358	2554	.380	
						1550	4943	.731	4798	.760	4632	.790	4448	.820	4246	.851	
						1625	5182	.842	5045	.872	4889	.904	4717	.936	4530	.968	

Specifications are subject to change without notice or obligation

4-Blade, Heavy Duty Condenser Style

Dia.	Part Number	Model Number	Rot.	Pitch	Hub Location	RPM	Static Pressure										Pk.
							0" WC		.1" WC		.2" WC		.3" WC		.4" WC		
							CFM	HP	CFM	HP	CFM	HP	CFM	HP	CFM	HP	
24"	6130170001 6130160001	F05E10A2416CW F05E10A2416CCW	CW CCW	16°	Inter-changeable	825	3166	.131	2901	.151	2501	.174	1947	.202	1529	.228	2
						1075	4126	.291	3937	.316	3704	.343	3404	.372	3010	.406	
						1140	4375	.347	4199	.373	3988	.401	3725	.431	3389	.465	
						1550	5949	.872	5824	.907	5688	.944	5537	.981	5369	1.020	
						1625	6237	1.004	6118	1.042	5990	1.080	5849	1.119	5695	1.159	
24"	6130190001 6130180001	F05E10A2418CW F05E10A2418CCW	CW CCW	18°	Inter-changeable	825	3586	.143	3339	.171	2951	.200	2218	.231	1686	.260	2
						1075	4673	.317	4497	.353	4280	.390	3992	.428	3562	.468	
						1140	4956	.378	4791	.416	4594	.455	4346	.495	4006	.536	
						1550	6738	.949	6622	1.002	6494	1.054	6354	1.108	6198	1.161	
						1625	7064	1.094	6953	1.149	6834	1.204	6703	1.260	6559	1.316	
24"	6130210001 6130200001	F05E10A2420CW F05E10A2420CCW	CW CCW	20°	Inter-changeable	825	4094	.169	3781	.198	3275	.228	2309	.263	1689	.301	2
						1075	5334	.374	5112	.411	4836	.449	4463	.486	3883	.530	
						1140	5657	.445	5450	.485	5200	.526	4880	.567	4429	.609	
						1550	7691	1.120	7385	1.228	7207	1.283	7207	1.283	7007	1.338	
						1625	8063	1.290	7924	1.347	7773	1.404	7608	1.461	7425	1.519	
24"	60804301 60804401	F05E10A2423CW F05E10A2423CCW	CW CCW	23°	Inter-changeable	825	4188	.187	3829	.213	3415	.258	2262	.292	1550	.334	2
						1075	5457	.413	5112	.408	4857	.453	4611	.508	4322	.567	
						1140	5728	.484	5466	.506	5217	.550	4962	.601	4662	.655	
						1625	7742	1.266	7504	1.252	7296	1.290	7124	1.345	6964	1.408	
24"	60559701 60559801	F05E10A2427CW F05E10A2427CCW	CW CCW	27°	Inter-changeable	825	4958	.262	4570	.281	4103	.328	2761	.365	1904	.414	2
						1075	6329	.535	6081	.565	5829	.607	5546	.657	5183	.711	
						1140	6735	.627	6450	.673	6194	.723	5930	.774	5629	.825	
						1625	9042	1.548	8848	1.642	8670	1.705	8496	1.769	8323	1.835	
24"	60559901 60560001	F05E10A2433CW F05E10A2433CCW	CW CCW	33°	Inter-changeable	825	5879	.376	5526	.402	5041	.444	3560	.484	2322	.522	2
						1075	7519	.806	7293	.827	7029	.864	6700	.919	6235	.988	
						1140	7943	.935	7669	.965	7391	1.103	7089	1.071	6733	1.137	
						1625	10763	2.312	10586	2.359	10412	2.416	10237	2.481	10059	2.553	
26"	60760701 60760801	F05E10A2624CW F05E10A2624CCW	CW CCW	24°	Inter-changeable	850	5440	.333	5200	.375	4900	.412	4500	.448		1	
						1000	6400	.540	6200	.590	6000	.630	5700	.680			
						1140	7300	.810	7120	.860	6930	.910	6720	.960			
26"	60760901 60761001	F05E10A2627CW F05E10A2627CCW	CW CCW	27°	Inter-changeable	825	6062	.390	5748	.419	5370	.451	4875	.494	4139	.557	1
						1075	7899	.863	7666	.900	7410	.938	7123	.981	6791	1.029	
						1140	8376	1.029	8158	1.068	7920	1.108	7659	1.152	7364	1.200	
26"	60761101 60761201	F05E10A2633CW F05E10A2633CCW	CW CCW	33°	Inter-changeable	825	7346	.607	6959	.625	6495	.654	5893	.702	5015	.787	1
						1075	9572	1.342	9284	1.364	8968	1.392	8616	1.430	8211	1.479	
						1140	10150	1.602	9880	1.624	9588	1.652	9266	1.689	8906	1.736	
30"	6131250001 6131240001	F05E06A3027CW F05E06A3027CCW	CW CCW	27°	Inter-changeable	825	8550	.562	8000	.605	7249	.629	6104	.660	4500	.680	1
						1075	11141	1.242	10743	1.305	10273	1.350	9706	1.381	8993	1.409	
						1140	11814	1.482	11442	1.549	11012	1.600	10507	1.636	9895	1.665	
30"	6131270001 6131260001	F05E06A3033CW F05E06A3033CCW	CW CCW	33°	Inter-changeable	825	9646	.712	9047	.757	8289	.784	6991	.812	5100	.820	1
						1075	12569	1.575	12125	1.641	11634	1.689	11062	1.723	10339	1.752	
						1140	13329	1.878	12913	1.949	12458	2.003	11948	2.043	11332	2.074	



Interchangeable hubs for all 3, 4 and 5-Blade propellers can be ordered separately.

APPENDIX A

Propeller Performance Chart



5-Blade, Heavy Duty Condenser Style

Dia.	Part Number	Model Number	Rot.	Pitch	Hub Location	RPM	Static Pressure								Pk.		
							0" WC		.1" WC		.2" WC		.3" WC			.4" WC	
							CFM	HP	CFM	HP	CFM	HP	CFM	HP		CFM	HP
10"	60720101 60720201	Y102Y10A1027CW Y102Y10A1027CCW	CW CCW	27°	Inter-changeable	825	553	.018	421	.023							2
						1075	721	.040	620	.045	516	.053	367	.060			
						1140	764	.048	669	.053	573	.061	456	.069			
						1550	1039	.121	969	.127	900	.135	830	.145	757	.156	
						1625	1090	.139	1022	.145	956	.154	890	.164	822	.175	
12"	60720401	Y02Y12A1219CCW	CCW	19°	Inter-changeable	1140	820	.018	645	.030	395	.035	315	.404		2	
						1550	1115	.045	1030	.060	825	.077	610	.086			
						1725	1240	.062	1165	.080	1040	.098	775	.110			
12"	60720501 60720601	Y02Y12A1223CW Y02Y12A1223CCW	CW CCW	23°	Inter-changeable	1140	895	.022	720	.034	480	.040	390	.045		2	
						1550	1220	.055	1125	.068	940	.087	730	.098			
						1725	1354	.076	1273	.095	1145	.113	922	.125			
12"	60720701 60720801	Y02Y12A1227CW Y02Y12A1227CCW	CW CCW	27°	Inter-changeable	1140	970	.027	795	.036	575	.044	460	.049		2	
						1550	1320	.068	1215	.078	1050	.092	875	.104			
						1725	1470	.094	1375	.108	1250	.120	1080	.135			
14"	60721101 60721201	Y02Y14A1423CW Y02Y14A1423CCW	CW CCW	23°	Inter-changeable	1140	1190	.045	1020	.055	830	.065	670	.075		2	
						1550	1620	.113	1495	.127	1365	.142	1225	.154			
						1725	1800	.156	1695	.170	1580	.186	1450	.200			
14"	60721301 60721401	Y02Y14A1427CW Y02Y14A1427CCW	CW CCW	27°	Inter-changeable	1140	1330	.055	1130	.063	880	.076	725	.085		2	
						1550	1810	.138	1680	.145	1510	.160	1310	.178			
						1725	2015	.191	1900	.200	1760	.212	1580	.230			
16"	60560101 60560201	Y08Y16A1627CW Y08Y16A1627CCW	CW CCW	27°	Inter-changeable	825	1556	.058	1381	.069	785	.084	462	.096		2	
						1075	2058	.120	1928	.130	1723	.148	1197	.165	887		.179
						1140	2178	.138	2058	.146	1882	.163	1486	.191	1075		.205
						1625	2883	.323	2805	.336	2714	.353	2598	.374	2438		.400
16"	6130230001 6130220001	Y08Y16A1629CW Y08Y16A1629CCW	CW CCW	29°	Inter-changeable	825	1690	.052	1431	.067	1068	.079	678	.091	426	.103	2
						1075	2202	.115	2017	.136	1792	.154	1515	.170	1196	.184	
						1140	2335	.137	2163	.159	1958	.179	1711	.197	1420	.212	
						1550	3175	.344	3055	.375	2920	.405	2772	.433	2611	.459	
16"	60560301 60560401	Y08Y16A1633CW Y08Y16A1633CCW	CW CCW	33°	Inter-changeable	825	1963	.085	1757	.094	948	.109	577	.127		2	
						1075	2532	.179	2394	.182	2193	.199	1554	.226	1054		.236
						1140	2673	.216	2537	.216	2374	.231	2119	.257	1187		.272
						1625	3552	.479	3467	.484	3371	.497	3262	.517	3113		.544
18"	6130250001 6130240001	Y08Y18A1828CW Y08Y18A1828CCW	CW CCW	25°	Inter-changeable	825	2200	.082	2000	.097	1570	.114	1079	.138	678	.127	2
						1075	2867	.182	2734	.201	2538	.219	2217	.240	1786	.274	
						1140	3040	.217	2918	.237	2745	.257	2485	.277	2093	.307	
						1550	4133	.545	4052	.572	3951	.600	3831	.627	3685	.654	
18"	60560501 60560601	Y08Y18A1827CW Y08Y18A1827CCW	CW CCW	27°	Inter-changeable	825	2153	.074	1917	.092	1199	.111	777	.130	481	.155	2
						1075	2789	.151	2644	.172	2446	.199	2003	.231	1357	.246	
						1140	2951	.182	2798	.197	2618	.222	2351	.257	1626	.280	
						1625	4086	.457	3986	.476	3881	.504	3766	.538	3636	.578	
18"	6130270001 6130260001	Y08Y18A1831CW Y08Y18A1831CCW	CW CCW	31°	Inter-changeable	825	2418	.100	2192	.195	1826	.338	1300	.595	1024	.174	2
						1075	3151	.222	2992	.342	2788	.473	2513	.650	2150	.934	
						1140	3342	.265	3194	.392	3010	.527	2772	.695	2462	.945	
						1550	4543	.668	4440	.839	4324	1.013	4194	1.192	4046	1.385	
18"	60560701 60560801	Y08Y18A1833CW Y08Y18A1833CCW	CW CCW	33°	Inter-changeable	825	2598	.119	2357	.130	1685	.156	936	.173	564	.206	2
						1075	3327	.249	3152	.258	2932	.284	2534	.321	1546	.329	
						1140	3517	.292	3379	.301	3195	.319	2881	.350	1979	.380	
						1625	4848	.747	4764	.764	4670	.786	4562	.814	4433	.849	

Specifications are subject to change without notice or obligation

5-Blade, Heavy Duty Condenser Style

Dia.	Part Number	Model Number	Rot.	Pitch	Hub Location	RPM	Static Pressure										Pk.
							0" WC		.1" WC		.2" WC		.3" WC		.4" WC		
							CFM	HP	CFM	HP	CFM	HP	CFM	HP	CFM	HP	
20"	6130290001 6130280001	Y08Y20A2025CW Y08Y20A2025CCW	CW CCW	25°	Inter-changeable	825	2583	.116	2320	.129	1956	.144	1484	.160	1024	.174	2
						1075	3366	.257	3176	.272	2949	.291	2673	.311	2341	.332	
						1140	3569	.306	3392	.323	3185	.342	2938	.363	2646	.385	
						1550	4853	.769	4727	.791	4591	.815	4442	.840	4279	.867	
20"	60560901 60561001	Y08Y20A2027CW Y08Y20A2027CCW	CW CCW	27°	Inter-changeable	850	2890	.130	2600	.150	2200	.163	1620	.185		2	
						1000	3350	.220	3100	.250	2850	.275	2500	.295			
						1140	3800	.330	3600	.350	3400	.370	3100	.400			
20"	6130310001 6130300001	Y08Y20A2030CW Y08Y20A2030CCW	CW CCW	30°	Inter-changeable	825	3061	.140	2644	.155	2132	.179	1639	.203	1190	.224	2
						1075	3988	.310	3691	.327	3330	.352	2935	.383	2543	.416	
						1140	4230	.369	3953	.387	3621	.413	3253	.445	2879	.479	
						1550	5751	.929	5557	.951	5341	.978	5102	1.011	4844	1.050	
20"	60561101 60561201	Y08Y20A2033CW Y08Y20A2033CCW	CW CCW	33°	Inter-changeable	850	3460	.183	3180	.204	2750	.225	2200	.240		2	
						1000	4050	.300	3800	.320	3520	.350	3120	.370			
						1140	4650	.440	4450	.455	4210	.480	3960	.510			
22"	60561301 60561401	Y12E07A2227CW Y12E07A2227CCW	CW CCW	27°	Inter-changeable	850	4050	.190	3725	.220	3270	.240	2425	.262		2	
						1000	4700	.320	4500	.335	4170	.350	3800	.390			
						1140	5400	.475	5230	.490	4960	.520	4650	.545			
22"	60561501 60561601	Y12E07A2233CW Y12E07A2233CCW	CW CCW	33°	Inter-changeable	850	4800	.322	4425	.340	3875	.355	2850	.365		2	
						1000	5700	.530	5350	.550	4950	.565	4420	.572			
						1140	6500	.775	6250	.800	5850	.825	5450	.850			
24"	60561701 60561801	Y12E07A2427CW Y12E07A2427CCW	CW CCW	27°	Inter-changeable	825	5056	.284	4631	.314	4109	.337	2446	.354	1722	.401	2
						1075	6577	.627	6240	.664	5908	.702	5525	.737	4966	.760	
						1140	6942	.749	6626	.794	6332	.832	6015	.864	5624	.889	
						1625	9783	2.019	9608	2.088	9429	2.156	9249	2.156	9064	2.286	
24"	60561901 60562001	Y12E07A2433CW Y12E07A2433CCW	CW CCW	33°	Inter-changeable	825	5791	.387	5409	.420	4789	.443	2875	.451	1919	.501	2
						1075	7555	.838	7258	.875	6922	.914	6509	.952	5892	.980	
						1140	7956	.984	7708	1.035	7418	1.084	7070	1.126	6604	1.157	
						1625	11179	2.750	11006	2.882	10825	2.894	10634	2.965	10431	3.035	
26"	60761301 60761401	Y12E07A2627CW Y12E07A2627CCW	CW CCW	27°	Inter-changeable	850	6600	.500	6170	.530	5690	.560	5080	.586		1	
						1000	7765	.814	7420	.848	7040	.884	6580	.920			
						1140	8850	1.205	8540	1.240	8220	1.280	7875	1.328			
26"	6130330001 6130320001	Y12E07A2629CW Y12E07A2629CCW	CW CCW	29°	Inter-changeable	825	6194	.313	5626	.356	4648	.383	3178	.396	2361	.438	1
						1075	8071	.692	7671	.751	7161	.802	6441	.836	5342	.852	
						1140	8559	.826	8187	.889	7728	.944	7120	.988	6235	1.012	
26"	60761501 60761601	Y12E07A2633CW Y12E07A2633CCW	CW CCW	33°	Inter-changeable	850	7700	.710	7125	.760	6500	.800	5700	.824		1	
						1000	9060	1.156	8580	1.211	8060	1.265	7520	1.310			
						1140	10330	1.712	9920	1.772	9470	1.832	9020	1.896			
28"	6130350001 6130340001	Y12E07A2827CW Y12E07A2827CCW	CW CCW	27°	Inter-changeable	825	7350	.591	6725	.633	5950	.674	5107	.686	4299	.710	1
						1075	9577	1.307	9127	1.358	8594	1.419	8001	1.474	7365	1.508	
						1140	10156	1.559	9738	1.611	9245	1.676	8700	1.739	8113	1.785	
28"	6130370001 6130360001	T12E07A2829CW T12E07A2829CCW	CW CCW	29°	Inter-changeable	825	7550	.660	6918	.701	6093	.731	5268	.750	4447	.780	1
						1075	9838	1.461	9395	1.514	8835	1.565	8199	1.605	7549	1.632	
						1140	10432	1.743	10022	1.799	9510	1.854	8924	1.900	8309	1.933	
28"	6130390001 6130380001	Y12E07A2833CW Y12E07A2833CCW	CW CCW	33°	Inter-changeable	825	8125	.830	7421	.850	6619	.869	5722	.899	4949	.930	1
						1075	10587	1.836	10058	1.864	9495	1.888	8884	1.912	8215	1.943	
						1140	11227	2.189	10733	2.220	10206	2.245	9643	2.270	9032	2.299	
30"	6130410001 6130400001	Y12E07A3027CW Y12E07A3027CCW	CW CCW	27°	Inter-changeable	825	9229	.898	8638	.955	7885	1.001	7012	1.029	6136	1.051	1
						1075	12025	1.987	11597	2.063	11097	2.134	10523	2.194	9879	2.241	
						1140	12752	2.369	12352	2.451	11892	2.527	11369	2.594	10785	2.649	



Interchangeable hubs for all 3, 4 and 5-Blade propellers can be ordered separately.

Continued on next page

Specifications are subject to change without notice or obligation

APPENDIX A

Propeller Performance Chart



5-Blade, Heavy Duty Condenser Style

Dia.	Part Number	Model Number	Rot.	Pitch	Hub Location	RPM	Static Pressure								Pk.		
							0" WC		.1" WC		.2" WC		.3" WC			.4" WC	
							CFM	HP	CFM	HP	CFM	HP	CFM	HP		CFM	HP
30"	6130430001	Y12E07A3029CW	CW	29°	Inter-changeable	825	9600	.980	8800	1.020	8100	1.080	7300	1.100	6400	1.110	1
	6130420001	Y12E07A3029CCW	CCW			1075	12509	2.168	11845	2.194	11307	2.285	10774	2.365	10204	2.416	
						1140	13265	2.586	12628	2.606	12114	2.700	11616	2.792	11096	2.859	
30"	6130450001	Y12E07A3033CW	CW	33°	Inter-changeable	825	10300	1.200	9400	1.220	8500	1.24	7200	1.280	6500	1.320	1
	6130440001	Y12E07A3033CCW	CCW			1075	13421	2.655	12622	2.683	12083	2.706	11426	2.731	10392	2.770	
						1140	14232	3.166	13449	3.197	12942	3.221	12376	3.246	11568	3.279	



Interchangeable hubs for all 3, 4 and 5-Blade propellers can be ordered separately.

3-Blade, Large Heavy Duty Steel

Dia.	Part Number	Model Number	Rot.	Pitch	RPM	Static Pressure								Max RPM	Approx Wt (lbs) Less Ctn / Max HP
						0" WC		.1" WC		.2" WC		.3" WC			
						RPM	CFM	HP	CFM	HP	CFM	HP	CFM		
30"	61093601	T16E06G3022TAPCW	CW	22°	850	7430	0.35	6790	0.39	5900	0.41	4430	0.43	1140	7.0
					1000	8730	0.58	8220	0.62	7580	0.65	6710	0.68		
					1140	9960	0.85	9520	0.90	9000	0.94	8370	0.98		
30"	61093701	T16E06G3027TAPCW	CW	27°	850	8510	0.49	7740	0.52	6800	0.54	5540	0.56	1140	7.0
					1000	10010	0.79	9380	0.83	8650	0.86	7780	0.88		
					1140	11380	1.18	10830	1.22	10220	1.25	9530	1.29		
36"	61093801	T16E06G3627TAPCW	CW	27°	720	11450	0.56	10250	0.61	8600	0.64	6210	0.64	1000	8.0
					850	13520	0.92	12540	0.98	11340	1.03	9790	1.05		
					1000	15900	1.49	15090	1.57	14160	1.63	13070	1.68		
36"	61093901	T16E06G3633TAPCW	CW	33°	720	13190	0.81	12000	0.86	10390	0.89	7890	0.88	1000	8.0
					850	15570	1.33	14600	1.40	13420	1.45	11900	1.46		
					1000	18320	2.16	17520	2.25	16600	2.32	15530	2.36		

4-Blade, Large Heavy Duty Steel

Dia.	Part Number	Rot.	Pitch	RPM	Static Pressure								Max RPM	Approx Wt (lbs) Less Ctn / Max HP
					0" WC		.1" WC		.2" WC		.3" WC			
					CFM	HP	CFM	HP	CFM	HP	CFM	HP		
24"	60832901	CW	27°	850	5070	0.26	4580	0.28	3850	0.32	2690	0.34	1335	6.8 / 1.2
				1000	5960	0.42	5560	0.45	5050	0.48	4330	0.52		
				1140	6790	0.62	6450	0.65	6050	0.69	5520	0.73		
26"	60833001	CW	27°	850	6730	0.46	6210	0.49	5560	0.52	4610	0.54	1140	7.0 / 1.2
				1000	7910	0.74	7470	0.78	7020	0.82	6400	0.85		
				1140	9020	1.10	8630	1.14	8250	1.18	7800	1.22		
28"	60833101	CW	27°	750	7410	0.45	6780	0.49	5950	0.52	4450	0.54	950	7.8 / 1.2
				850	8400	0.66	7840	0.70	7200	0.74	6370	0.77		
				950	10267	0.99	9700	1.06	8965	1.10	8527	1.14		
30"	60833201	CW	27°	720	7970	0.47	7170	0.54	6400	0.58	5250	0.63	950	8.0 / 1.25
				850	9410	0.78	8750	0.85	8050	0.93	7400	0.96		
				940	10402	1.05	9809	1.13	9169	1.21	8570	1.25		
36"	60833301	CW	27°	500	10170	0.45	8820	0.51	6750	0.55	4400	0.60	765	12.0 / 1.9
				720	14650	1.35	13800	1.44	12800	1.52	11600	1.59		
				765	15155	1.90	14354	1.99	13381	1.67	12303	1.75		

Specifications are subject to change without notice or obligation



APPENDIX A Propeller Performance Chart

Appendix A

4-Blade, Large Heavy Duty Steel

Dia.	Part Number	Rot.	Pitch	RPM	Static Pressure								Max RPM	Approx Wt (lbs) Less Ctn / Max HP
					0" WC		.1" WC		.2" WC		.3" WC			
					CFM	HP	CFM	HP	CFM	HP	CFM	HP		
42"	60833401	CW	27°	500	15440	0.99	13640	1.05	11600	1.10	8500	1.18	630	20.0 / 2.45
				600	18520	1.71	17010	1.77	15500	1.85	13700	1.92		
				630	19441	1.98	18007	2.04	16603	2.14	14917	2.18		
48"	60833501	CW	27°	300	14240	0.40	10520	0.47	4920	0.53	2500	0.65	525	25.0 / 2.45
				400	18990	0.95	16600	1.01	13208	1.18	8080	1.20		
				500	23750	1.86	21820	1.94	19650	2.03	16900	2.18		
54"	60833601	CW	27°	300	19800	0.76	15620	0.84	9100	0.88	6250	1.04	575	50.0 / 6.0
				400	26360	1.80	23650	1.90	19800	2.01	14200	2.08		
				500	32950	3.51	30870	3.69	28500	3.76	25165	3.91		
				575	37900	5.34	36080	5.54	34120	5.63	32000	5.83		
60"	60833701	CW	27°	200	17500	0.33	8900	0.40	3650	0.53	850	0.73	525	60.0 / 6.5
				300	26210	1.13	22550	1.25	14950	1.33	10250	1.43		
				400	34950	2.67	32330	2.84	29120	2.96	24200	3.15		
				475	41500	4.48	39300	4.67	37070	4.88	33950	4.96		
60"	60834301	CW	40°	200	22000	0.61	13260	0.68	6950	0.80	3320	1.02	470	60.0 / 6.5
				300	33000	2.06	28920	2.18	21700	2.18	16180	2.36		
				400	44000	4.88	41000	5.05	37820	5.21	33150	5.38		
				460	50600	7.42	48000	7.62	45350	7.81	42500	7.97		

6-Blade, Large Heavy Duty Steel

Dia.	Part Number	Rot.	Pitch	RPM	Static Pressure								Max RPM	Approx Wt (lbs) Less Ctn / Max HP
					0" WC		.1" WC		.2" WC		.3" WC			
					CFM	HP	CFM	HP	CFM	HP	CFM	HP		
30"	60833801	CW	40°	720	11062	1.23	10274	1.27	9418	1.29	8212	1.31	1140	18.0 / 3.65
				850	13059	2.02	12402	2.07	11711	2.11	10938	2.12		
				1000	15364	3.29	14811	3.35	14228	3.40	13642	3.44		
				1140	17515	4.88	17030	4.94	16529	5.00	16014	5.05		
36"	60833901	CW	40°	500	11564	0.76	10176	0.80	8298	0.81	5691	0.85	860	21.0 / 4.45
				720	16652	2.28	15301	2.35	14736	2.37	13600	2.39		
				850	19659	3.74	18938	3.83	18146	3.89	17195	3.91		
				1000	23128	6.10	22515	6.19	21902	6.29	21161	6.34		
42"	60834001	CW	40°	500	17992	1.68	16799	1.76	15408	1.80	13429	1.84	650	32.0 / 3.70
				600	21590	2.90	20576	3.00	19541	3.07	18346	3.12		
				720	25908	5.01	25051	5.13	24249	5.23	23330	5.31		
				850	30585	8.24	29859	8.38	29154	8.51	28485	8.63		
48"	60834101	CW	40°	300	15815	0.61	13110	0.67	6811	0.71	3587	0.82	500	37.0 / 3.70
				400	21087	1.44	19175	1.55	16562	1.65	11536	1.74		
				500	26358	2.81	24985	2.95	23162	3.06	21123	3.19		
				600	31630	4.85	30485	5.02	29157	5.18	27615	5.30		
54"	60834201	CW	40°	300	22741	1.13	19501	1.22	13772	1.34	8105	1.35	555	57.0 / 8.00
				400	30320	2.68	28051	2.80	25216	2.93	21881	3.04		
				500	37899	5.24	36138	5.38	34220	5.53	31906	5.70		
				575	43583	8.00	42053	8.12	40435	8.30	38758	8.47		

Specifications are subject to change without notice or obligation

APPENDIX A

Propeller Performance Chart



4-Blade, Large Extra Heavy Duty Steel

Dia.	Part Number	Rot.	Pitch	RPM	Static Pressure						Max HP	Max RPM	Approx Wt (lbs)
					0" WC		.25" WC		.5" WC				
					CFM	HP	CFM	HP	CFM	HP			
24"	6126890001	CW	27°	1250	7415	0.82	6596	0.91	5157	1.03	2.1	1640	7
				1425	8454	1.21	7780	1.31	6749	1.45			
				1600	9492	1.71	8906	1.83	8124	1.97			
26"	6126890002	CW	27°	1200	9489	1.28	8580	1.39	7312	1.49	2.1	1350	9
				1280	10121	1.55	9269	1.67	8143	1.78			
				1350	10675	1.82	9867	1.95	8845	2.07			
28"	6126890003	CW	27°	1000	10807	1.16	9225	1.29	6200	1.38	2.1	1140	10
				1075	11618	1.44	10184	1.59	7823	1.70			
				1140	12321	1.71	10995	1.88	9008	2.06			
37"	6126890004	CW	27°	1000	11066	1.27	9617	1.49	7929	1.63	2.8	1230	11
				1140	12615	1.88	11349	2.13	10121	2.30			
				1220	13501	2.30	12325	2.57	11146	2.79			
36"	6126890005	CW	27°	800	15849	1.72	13672	1.94	10280	2.11	3.5	905	18
				850	16839	2.06	14838	2.29	11929	2.50			
				905	17929	2.48	16088	2.74	13555	2.96			
42"	6126890006	CW	27°	650	20058	2.18	16552	2.36	11286	2.57	4.5	835	25
				725	22372	3.02	19287	3.25	15537	3.39			
				800	24687	4.06	21879	4.29	18705	4.49			
48"	6126890007	CW	27°	540	25625	2.35	20825	2.58	11881	2.90	5.2	685	37
				605	28709	3.30	24691	3.53	18959	3.87			
				675	32031	4.58	28498	4.84	23793	5.20			
54"	6126890008	CW	27°	585	38543	5.63	33847	5.93	27085	6.52	7.6	610	59
				600	39531	6.07	34973	6.40	28395	6.95			
				610	40190	6.38	35719	6.72	29295	7.25			
60"	6126890009	CW	27°	500	43669	5.22	38408	5.76	27244	6.16	8.5	565	69
				535	46726	6.40	41826	6.97	34063	7.42			
				565	48910	7.34	44240	7.92	37567	8.35			

6-Blade, Large Extra Heavy Duty Steel

Dia.	Part Number	Rot.	Pitch	RPM	Static Pressure						Max HP	Max RPM	Approx Wt (lbs)
					0" WC		.25" WC		.5" WC				
					CFM	HP	CFM	HP	CFM	HP			
30"	6126890010	CW	40°	1160	16433	3.68	15386	3.91	13946	4.16	4.7	1220	21
				1200	17000	4.07	15996	4.31	14696	4.59			
				1220	17283	4.28	16295	4.52	15044	4.70			
36"	6126890011	CW	40°	870	20910	3.94	19314	4.10	16183	4.43	5.8	940	27
				900	21631	4.37	20089	4.52	17781	4.87			
				940	22593	4.98	21116	5.14	19004	5.48			
42"	6126890012	CW	40°	700	24935	3.72	22469	4.04	19374	4.44	8.0	860	40
				780	27784	5.15	25592	5.47	23191	5.95			
				860	30634	6.90	28656	7.24	26571	7.75			
48"	6126890013	CW	40°	575	32511	4.58	28697	4.78	22924	5.07	8.0	675	46
				625	35338	5.88	31848	6.07	27029	6.47			
				675	38165	7.40	34953	7.58	30946	8.00			
54"	6126890014	CW	40°	570	43936	8.06	39981	8.42	34929	8.78	10.75	610	77
				590	45478	8.94	41700	9.32	37282	9.68			
				610	47019	9.87	43408	10.29	39542	10.64			

Specifications are subject to change without notice or obligation



APPENDIX A Propeller Performance Chart

2-Blade, Cobra

Dia.	Part Number	Model Number	Rot.	Pitch	Hub Location	RPM	Static Pressure										Pk.
							0" WC		.1" WC		.2" WC		.3" WC		.4" WC		
							CFM	HP	CFM	HP	CFM	HP	CFM	HP	CFM	HP	
22"	6140560001	S10HS9A 2220 CW .50 I	CW	20°	Inter-changeable	825	2651	0.062	2169	0.081							1
						1075	3454	0.138	3105	0.157	2686	0.188					
						1140	3663	0.164	3330	0.184	2960	0.217	2220	0.25			
22"	6140600001	S10HS9A 2224 CW .50 I	CW	24°	Inter-changeable	825	3054	0.085	2560	0.105						1	
						1075	3980	0.189	3618	0.209	3216	0.24					
						1140	4220	0.225	3922	0.242	3538	0.276					
22"	6140650001	S10HS9A 2228 CW .50 I	CW	28°	Inter-changeable	825	3369	0.117	2859	0.136						1	
						1075	4390	0.259	3991	0.279	3592	0.312	2971	0.349			
						1140	4656	0.309	4279	0.329	3903	0.364	3433	0.401			
22"	6140710001	S10HS9A 2234 CW .50 I	CW	34°	Inter-changeable	825	3868	0.183	3360	0.204						1	
						1075	5040	0.405	4683	0.416	4276	0.463	3716	0.52			
						1140	5344	0.483	5020	0.491	4588	0.545	4157	0.599			
24"	6139700001	S10HS6A 2420 .50 CCW I	CCW	20°	Inter-changeable	825	2849	0.067	2360	0.084						1	
						1075	3712	0.148	3375	0.158	2925	0.197					
						1140	3937	0.176	3619	0.185	3221	0.224					
24"	6139820001	S10HS6A 2424 .50 CCW I	CCW	24°	Inter-changeable	825	3329	0.091	2825	0.107						1	
						1075	4338	0.201	3944	0.209	3550	0.251					
						1140	4601	0.239	4229	0.245	3857	0.289	3346	0.338			
24"	6139900001	S10HS6A 2428 .50 CCW I	CCW	28°	Inter-changeable	825	3877	0.133	3329	0.149	2585	0.187				1	
						1075	5052	0.295	4593	0.298	4235	0.345	3776	0.396			
						1140	5357	0.351	4924	0.349	4600	0.394	4167	0.456			
24"	6140020001	S10HS6A 2434 .50 CCW I	CCW	34°	Inter-changeable	825	4530	0.206	3935	0.215	3340	0.271				1	
						1075	5903	0.457	5366	0.436	5008	0.497	4591	0.57			
						1140	6260	0.545	5754	0.512	5375	0.579	4995	0.658	4489		0.612
26"	6140160001	S10HS8A 2620 .50 CCW I	CCW	20°	Inter-changeable	825	3467	0.085	2907	0.108						1	
						1075	4518	0.189	4061	0.212	3651	0.253					
						1140	4791	0.225	4355	0.248	3968	0.291	3339	0.333			
26"	6140220001	S10HS8A 2624 .50 CCW I	CCW	24°	Inter-changeable	825	4085	0.12	3548	0.139	2806	0.177				1	
						1075	5322	0.265	4838	0.281	4516	0.321	4032	0.373			
						1140	5644	0.316	5188	0.328	4846	0.375	4447	0.428			
26"	6140300001	S10HS8A 2628 .50 CCW I	CCW	28°	Inter-changeable	825	4751	0.172	4175	0.186	3600	0.232				1	
						1075	6191	0.382	5753	0.373	5378	0.421	4940	0.486			
						1140	6566	0.455	6101	0.444	5770	0.491	5372	0.56	4841		0.625
26"	6140440001	S10HS8A 2634 .50 CCW I	CCW	34°	Inter-changeable	825	5680	0.275	4992	0.277	4476	0.338				1	
						1075	7402	0.609	6804	0.564	6430	0.629	6056	0.707			
						1140	7849	0.727	7294	0.663	6898	0.731	6581	0.806			
28"	6139520001	S10HS4A 2820 .50 CCW I	CCW	20°	Inter-changeable	825	3960	0.099	3200	0.128						1	
						1075	5160	0.218	4483	0.249	4014	0.299					
						1140	5472	0.26	4809	0.29	4422	0.338	3759	0.388			
28"	6139550001	S10HS4A 2824 .50 CCW I	CCW	24°	Inter-changeable	825	4634	0.143	3979	0.163	3323	0.206				1	
						1075	6038	0.316	5428	0.328	5062	0.379	4635	0.432			
						1140	6403	0.376	5821	0.382	5433	0.441	5045	0.5			
28"	6139580001	S10HS4A 2828 .50 CCW I	CCW	28°	Inter-changeable	825	5389	0.212	4790	0.214	4246	0.269				1	
						1075	7022	0.468	6454	0.444	6100	0.497	5674	0.572	5107		0.643
						1140	7446	0.558	6920	0.522	6544	0.578	6168	0.653			
28"	6139610001	S10HS4A 2834 .50 CCW I	CCW	34°	Inter-changeable	825	6516	0.321	5792	0.321	5331	0.379	4409	0.44		1	
						1075	8490	0.71	7890	0.659	7461	0.728	7118	0.802			
						1140	9003	0.847	8367	0.786	8003	0.848	7639	0.934			

Specifications are subject to change without notice or obligation

APPENDIX A

Propeller Performance Chart



3-Blade, Cobra

Dia.	Part Number	Model Number	Rot.	Pitch	Hub Location	RPM	Static Pressure										Pk.
							0" WC		.1" WC		.2" WC		.3" WC		.4" WC		
							CFM	HP	CFM	HP	CFM	HP	CFM	HP	CFM	HP	
22"	6140570001	T10HS9A 2220 CW .50 I	CW	20°	Inter-changeable	825	2731	0.076	2427	0.093							1
						1075	3558	0.167	3342	0.184	3055	0.220	2552	0.268			
						1140	3773	0.200	3545	0.219	3316	0.251	2935	0.3			
22"	6140610001	T10HS9A 2224 CW .50 I	CW	24°	Inter-changeable	825	3215	0.109	2857	0.128	2240	0.159				1	
						1075	4189	0.241	3935	0.260	3639	0.292	3216	0.332			
						1140	4442	0.287	4218	0.306	3948	0.337	3589	0.378			
22"	6140660001	T10HS9A 2228 CW .50 I	CW	28°	Inter-changeable	825	3611	0.150	3173	0.163	2553	0.203				1	
						1075	4705	0.331	4372	0.336	4039	0.372	3612	0.423			
						1140	4989	0.395	4687	0.396	4384	0.430	3981	0.486	3427		0.487
22"	6140720001	T10HS9A 2234 CW .50 I	CW	34°	Inter-changeable	825	4194	0.238	3686	0.249	3093	0.289				1	
						1075	5465	0.525	5078	0.522	4692	0.564	4250	0.618			
						1140	5795	0.627	5444	0.618	5034	0.664	4683	0.714			
24"	6139720001	T10HS6A 2420 .50 CCW I	CCW	20°	Inter-changeable	825	3201	0.084	2748	0.116	1972	0.141				1	
						1075	4171	0.185	3792	0.226	3497	0.267	3034	0.306			
						1140	4423	0.221	4066	0.263	3753	0.312	3396	0.353			
24"	6139840001	T10HS6A 2424 .50 CCW I	CCW	24°	Inter-changeable	825	3701	0.119	3252	0.150	2729	0.189				1	
						1075	4822	0.263	4481	0.291	4140	0.348	3799	0.398			
						1140	5114	0.313	4804	0.339	4494	0.396	4184	0.452	3668		0.420
24"	6139920001	T10HS6A 2428 .50 CCW I	CCW	28°	Inter-changeable	825	4262	0.166	3789	0.194	3358	0.239				1	
						1075	5554	0.367	5161	0.389	4881	0.441	4544	0.504	3927		0.561
						1140	5890	0.437	5533	0.454	5236	0.512	4938	0.577	4522		0.646
24"	6140040001	T10HS6A 2434 .50 CCW I	CCW	34°	Inter-changeable	825	4962	0.254	4460	0.281	4009	0.339				1	
						1075	6465	0.562	6073	0.570	5747	0.636	5355	0.725	4898		0.793
						1140	6856	0.671	6440	0.679	6163	0.74	5817	0.831	5471		0.907
26"	6140190001	T10HSE8A 2620 .50 CCW I	CW	20°	Inter-changeable	825	3558	0.101	2983	0.128	2300	0.163				1	
						1075	4636	0.223	4121	0.254	3793	0.295	3278	0.344			
						1140	4917	0.266	4420	0.296	4072	0.345	3675	0.393	3029		0.437
26"	6140250001	T10HSE8A 2624 .50 CW D	CW	24°	Inter-changeable	825	4175	0.144	3711	0.168	3121	0.210				1	
						1075	5440	0.319	5056	0.342	4726	0.387	4286	0.444	3407		0.497
						1140	5769	0.380	5419	0.401	5070	0.452	4720	0.506			
26"	6140330001	T10HSE8A 2628 .50 CW D	CW	28°	Inter-changeable	825	4918	0.208	4471	0.214	3974	0.267				1	
						1075	6409	0.461	6085	0.444	5696	0.495	5373	0.556			
						1140	6796	0.550	6453	0.530	6110	0.577	5835	0.634	5423		0.640
26"	6140470001	T10HSE8A 2634 .50 CW D	CW	34°	Inter-changeable	825	6044	0.334	5494	0.324	4945	0.397				1	
						1075	7875	0.738	7398	0.688	7000	0.749	6602	0.842	6205		0.931
						1140	8351	0.881	7929	0.816	7508	0.874	7170	0.958			
28"	6139530001	T10HS4A 2820 .50 CCW I	CCW	20°	Inter-changeable	825	4113	0.133	3407	0.163	2825	0.193				1	
						1075	5359	0.294	4655	0.332	4331	0.374	3897	0.415			
						1140	5683	0.351	4994	0.388	4650	0.438	4305	0.479			
28"	6139560001	T10HS4A 2824 .50 CCW I	CCW	24°	Inter-changeable	825	4918	0.189	4223	0.213	3776	0.260				1	
						1075	6409	0.418	5761	0.424	5373	0.496	5049	0.555	4596		0.614
						1140	6796	0.498	6110	0.506	5766	0.577	5492	0.635	5080		0.707
28"	6139590001	T10HS4A 2828 .50 CCW I	CCW	28°	Inter-changeable	825	5800	0.277	5156	0.285	4746	0.341	4043	0.403		1	
						1075	7558	0.613	7024	0.577	6642	0.646	6260	0.738			
						1140	8015	0.731	7448	0.688	7124	0.751	6801	0.836	6477		0.921
28"	6139620001	T10HS4A 2834 .50 CCW I	CCW	34°	Inter-changeable	825	7078	0.448	6506	0.423	6006	0.492	5434	0.572		1	
						1075	9223	0.991	8758	0.910	8292	0.971	7919	1.063	7546		1.162
						1140	9781	1.182	9287	1.085	8892	1.135	8595	1.21			

Specifications are subject to change without notice or obligation



APPENDIX A Propeller Performance Chart

4-Blade, Cobra

Dia.	Part Number	Model Number	Rot.	Pitch	Hub Location	RPM	Static Pressure										Pk.
							0" WC		.1" WC		.2" WC		.3" WC		.4" WC		
							CFM	HP	CFM	HP	CFM	HP	CFM	HP	CFM	HP	
22"	6140580001	F10HS9A 2220 CW .50 I	CW	20°	Inter-changeable	825	2794	0.097	2540	0.112	2060	0.148					1
						1075	3641	0.215	3457	0.229	3236	0.258	2869	0.307	2280	0.359	
						1140	3861	0.257	3705	0.269	3471	0.301	3198	0.344	2730	0.359	
22"	6140620001	F10HS9A 2224 CW .50 I	CW	24°	Inter-changeable	825	3284	0.121	2952	0.139	2388	0.182					1
						1075	4279	0.268	4063	0.281	3717	0.325	3328	0.378			
						1140	4538	0.32	4308	0.335	4033	0.373	3713	0.424	3208	0.437	
22"	6140670001	F10HS9A 2228 CW .50 I	CW	28°	Inter-changeable	825	3697	0.162	3286	0.183	2689	0.227					1
						1075	4817	0.359	4525	0.377	4185	0.417	3747	0.474			
						1140	5109	0.429	4851	0.444	4541	0.483	4128	0.544			
22"	6140730001	F10HS9A 2234 CW .50 I	CW	34°	Inter-changeable	825	4428	0.269	3891	0.272	3309	0.324					1
						1075	5769	0.596	5361	0.572	4953	0.619	4545	0.684			
						1140	6118	0.711	5747	0.68	5376	0.718	4944	0.794	4449	0.766	
24"	6139740001	F10HS6A 2420 .50 CCW I	CCW	20°	Inter-changeable	825	3133	0.104	2659	0.128	2279	0.163	1519	0.19	1108	0.229	1
						1075	4083	0.229	3671	0.245	3382	0.298	3134	0.339	2722	0.505	
						1140	4330	0.273	3893	0.293	3674	0.337	3411	0.389	3105	0.38	
24"	6139860001	F10HS6A 2424 .50 CCW I	CCW	24°	Inter-changeable	825	3734	0.152	3244	0.173	2867	0.216	1924	0.248			1
						1075	4866	0.336	4423	0.346	4177	0.393	3883	0.452	3489	0.507	
						1140	5160	0.401	4743	0.403	4482	0.457	4222	0.517	3909	0.577	
24"	6139940001	F10HS6A 2428 .50 CCW I	CCW	28°	Inter-changeable	825	4417	0.206	3881	0.224	3480	0.273					1
						1075	5755	0.457	5290	0.452	4941	0.521	4651	0.583	4244	0.648	
						1140	6103	0.545	5610	0.539	5302	0.606	5055	0.666	4685	0.745	
24"	6140060001	F10HS6A 2434 .50 CCW I	CCW	34°	Inter-changeable	825	5270	0.329	4738	0.321	4312	0.39	3726	0.452			1
						1075	6867	0.727	6381	0.671	6035	0.744	5757	0.823	5410	0.915	
						1140	7282	0.867	6767	0.800	6473	0.866	6252	0.934	5958	1.028	
26"	6140200001	F10HS8A 2620 .50 CCW I	CCW	20°	Inter-changeable	825	3756	0.137	3224	0.161	2845	0.200	2048	0.232			1
						1075	4894	0.304	4399	0.319	4152	0.365	3856	0.42	3460	0.284	
						1140	5189	0.362	4718	0.371	4456	0.424	4194	0.48	3879	0.472	
26"	6140260001	F10HS8A 2624 .50 CCW I	CCW	24°	Inter-changeable	825	4528	0.204	4024	0.22	3659	0.268	3064	0.312			1
						1075	5899	0.452	5482	0.446	5184	0.501	4886	0.567	4588	0.626	
						1140	6256	0.539	5814	0.531	5561	0.582	5308	0.645	4992	0.721	
26"	6140340001	F10HS8A 2628 .50 CCW I	CCW	28°	Inter-changeable	825	5356	0.285	4923	0.281	4544	0.333	4057	0.395			1
						1075	6979	0.63	6626	0.596	6344	0.634	6062	0.7			
						1140	7401	0.751	7027	0.711	6728	0.757	6504	0.814			
26"	6140480001	F10HS8A 2634 .50 CCW I	CCW	34°	Inter-changeable	825	6507	0.445	5981	0.414	5521	0.484	4995	0.568			1
						1075	8478	0.985	8050	0.892	7708	0.931	7365	1.019			
						1140	8991	1.174	8628	1.068	8264	1.091	7901	1.186	7538	1.307	
28"	6139540001	F10HS4A 2820 .50 CCW I	CCW	20°	Inter-changeable	825	4161	0.178	3488	0.201	3110	0.236	2522	0.262			1
						1075	5421	0.394	4710	0.416	4436	0.464	4162	0.507			
						1140	5749	0.47	5052	0.485	4820	0.53	4530	0.585	4239	0.63	
28"	6139570001	F10HS4A 2824 .50 CCW I	CCW	24°	Inter-changeable	825	5062	0.252	4346	0.262	3988	0.311	3528	0.355			1
						1075	6596	0.557	5863	0.536	5596	0.595	5330	0.659	5063	0.716	
						1140	6995	0.664	6288	0.625	6005	0.691	5723	0.767			
28"	6139600001	F10HS4A 2828 .50 CCW I	CCW	28°	Inter-changeable	825	5981	0.347	5256	0.350	4893	0.409	4410	0.474			1
						1075	7793	0.768	7084	0.720	6770	0.795	6455	0.884			
						1140	8264	0.916	7513	0.858	7262	0.922	6928	1.027			
28"	6139630001	F10HS4A 2834 .50 CCW I	CCW	34°	Inter-changeable	825	7515	0.543	6756	0.526	6300	0.607	5845	0.684			1
						1075	9792	1.202	9099	1.106	8704	1.191	8407	1.280			
						1140	10384	1.433	9754	1.307	9335	1.389	9020	1.490			

Continued on next page

Specifications are subject to change without notice or obligation

APPENDIX A

Standard Props to Cobra Props



Cobra Blades Cross Reference

Standard Catalog 2-Blade Props					2-Blade Cobra Props					3-Blade Cobra Props				
Part No.	Model	Dia.	Pitch	Rot.	Part No.	Model	Dia.	Pitch	Rot.	Part No.	Model	Dia.	Pitch	Rot.
6130580001	S10S08-2424	24"	24°	CCW	6139820001	S10HS6A-2424	24"	24°	CCW	6139720001	T10HS6A-2420	24"	20°	CCW

Standard Catalog 3-Blade Props					3-Blade Cobra Props					4-Blade Cobra Props				
Part No.	Model	Dia.	Pitch	Rot.	Part No.	Model	Dia.	Pitch	Rot.	Part No.	Model	Dia.	Pitch	Rot.
60557301	T12E10-2227	22"	27°	CW	6140720001	T10HS9A-2234	22"	34°	CW	N/A				
6129850001	T12E10-2230	22"	30°	CW	6140720001	T10HS9A-2234	22"	34°	CW	6140730001	F10HS9A-2234	22"	34°	CW
60557501	T12E10-2233	22"	33°	CW	6140720001	T10HS9A-2234	22"	34°	CW	6140730001	F10HS9A-2234	22"	34°	CW
6129870001	T12E10-2235	22"	35°	CW	N/A					6140730001	F10HS9A-2234	22"	34°	CW
60557801	T12E10-2427	24"	27°	CCW	N/A					6139940001	F10HS6A-2428	24"	28°	CCW
60558001	T12E10-2433	24"	33°	CCW	N/A					6140060001	F10HS6A-2434	24"	34°	CCW
61046601	T10S08-2626	26"	26°	CW	6140330001	T10HS8A-2628	26"	28°	CW	N/A				
6129890001	T10E10-2626	26"	26°	CW	6140470001	T10HS8A-2634	26"	34°	CW	N/A				
6129900001	T10E10-2633	26"	33°	CCW	N/A					6140480001	F10HS8A-2634	26"	34°	CCW
6130660001	T10S08-2637	26"	37°	CW	6140470001	T10HS8A-2634	26"	34°	CW	N/A				

Standard Catalog 4-Blade Props					4-Blade Cobra Props					3-Blade Cobra Props				
Part No.	Model	Dia.	Pitch	Rot.	Part No.	Model	Dia.	Pitch	Rot.	Part No.	Model	Dia.	Pitch	Rot.
60804101	F05E10-2223	22"	23°	CW	6140620001	F10HS9A-2224	22"	24°	CW	6140660001	T10HS9A-2228	22"	28°	CW
60559301	F05E10-2227	22"	27°	CW	6140670001	F10HS9A-2228	22"	28°	CW	N/A				
60559501	F05E10-2233	22"	33°	CW	6140730001	F10HS9A-2234	22"	34°	CW	N/A				
6130140001	F05E10-2413	24"	13°	CCW	6139740001	F10HS6A-2420	24"	20°	CCW	N/A				
6130160001	F05E10-2416	24"	16°	CCW	6139740001	F10HS6A-2420	24"	20°	CCW	6139720001	T10HS6A-2420	24"	20°	CCW
6130180001	F05E10-2418	24"	18°	CCW	6139860001	F10HS6A-2424	24"	24°	CCW	6139840001	T10HS6A-2424	24"	24°	CCW
6130200001	F05E10-2420	24"	20°	CCW	6139860001	F10HS6A-2424	24"	24°	CCW	6139840001	T10HS6A-2424	24"	24°	CCW
60804401	F05E10-2423	24"	23°	CCW	6139940001	F10HS6A-2428	24"	28°	CCW	6139920001	T10HS6A-2428	24"	28°	CCW
60559801	F05E10-2427	24"	27°	CCW	6140060001	F10HS6A-2434	24"	34°	CCW	6140040001	T10HS6A-2434	24"	34°	CCW
60760701	F05E10-2624	26"	24°	CW	N/A					6140470001	T10HS8A2634	26"	34°	CW
60760901	F05E10-2627	26"	27°	CW	6140480001	F10HS8A-2634	26"	34°	CW	N/A				

Specifications are subject to change without notice or obligation

Lau Parts Cross Reference

BELT DRIVE BLOWERS

Model Number	.25 SP			.5 SP		.75 SP		1.00 SP	
	CFM	RPM	BHP	RPM	BHP	RPM	BHP	RPM	BHP
A9-6ACE	400	556	0.07	783	0.11	992	0.15	1156	0.19
	600	575	0.09	769	0.13	950	0.17	1102	0.21
	800	630	0.12	794	0.16	958	0.21	1092	0.25
	1000	700	0.18	845	0.22	986	0.27	1100	0.37
A9-7ACE	400	553	0.07	807	0.09	986	0.14	1133	0.19
	600	563	0.09	790	0.13	954	0.19	1118	0.22
	800	599	0.11	793	0.16	946	0.22	1097	0.31
	1000	644	0.14	813	0.19	954	0.26	1092	0.34
A9-9ACE	600	566	0.10	788	0.14	998	0.20	1148	0.25
	800	589	0.12	787	0.16	972	0.23	1127	0.29
	1000	623	0.15	803	0.20	964	0.27	1109	0.33
	1200	663	0.19	828	0.25	980	0.33	1111	0.39
A10-6ACE	400	491	0.06	704	0.11	872	0.15	1014	0.18
	600	500	0.09	686	0.13	841	0.16	983	0.21
	800	529	0.12	697	0.16	838	0.21	964	0.26
	1000	577	0.16	724	0.21	854	0.27	969	0.31
A10-8ACE	600	477	0.08	700	0.11	863	0.17	1013	0.22
	800	492	0.10	693	0.14	836	0.18	981	0.25
	1000	517	0.12	690	0.17	829	0.22	963	0.31
	1200	550	0.17	727	0.23	836	0.30	956	0.35
A10-10ACE	400	490	0.13	700	0.20	859	0.28	1002	0.37
	600	507	0.16	693	0.21	843	0.30	977	0.38
	800	529	0.18	705	0.26	841	0.33	967	0.42
	1000	558	0.22	718	0.29	847	0.38	968	0.46
A12-6ACE	600	414	0.11	593	0.18	735	0.24	852	0.30
	800	417	0.11	577	0.19	712	0.26	835	0.32
	1000	439	0.14	586	0.22	708	0.30	812	0.36
	1200	472	0.18	602	0.27	712	0.34	811	0.41
A12-9ACE	1000	400	0.11	566	0.18	714	0.28	828	0.36
	1200	410	0.13	563	0.21	697	0.29	815	0.38
	1400	424	0.15	566	0.23	688	0.32	800	0.42
	1600	447	0.19	575	0.27	689	0.36	794	0.46

Model No.	CFM	.25 SP		.5 SP		.75 SP		1.00 SP	
		RPM	BHP	RPM	BHP	RPM	BHP	RPM	BHP
A12-12ACE	1400	424	0.16	574	0.26	700	0.33	816	0.42
	1600	436	0.18	579	0.29	702	0.37	809	0.47
	1800	451	0.22	587	0.32	704	0.42	811	0.51
	2000	463	0.26	596	0.37	711	0.47	812	0.56
	2200	486	0.30	609	0.42	718	0.52	817	0.62
	2400	507	0.36	623	0.47	728	0.58	823	0.69
A15-9ACE	2600	530	0.42	638	0.54	740	0.65	831	0.76
	1500	347	0.17	472	0.24	582	0.34	666	0.43
	2000	375	0.25	483	0.34	576	0.44	657	0.55
	2500	411	0.36	503	0.46	590	0.60	665	0.72
	3000	458	0.52	534	0.62	608	0.81	680	0.95
	3500	493	0.73	564	0.87	633	1.06	702	1.23
A15-11ACE	4000	540	1.05	605	1.22	667	1.42	729	1.55
	4500	589	1.37	648	1.58	703	1.80	761	2.02
	5000	637	1.75	690	2.05	745	2.30	800	2.50
	2000	344	0.21	459	0.30	562	0.42	654	0.52
	2500	368	0.30	467	0.40	563	0.52	652	0.66
	3000	398	0.41	487	0.53	573	0.67	654	0.82
A15-15ACE	3500	441	0.50	512	0.73	590	0.89	663	1.05
	4000	479	0.84	543	1.00	611	1.17	679	1.32
	2000	350	0.20	480	0.31	595	0.45	696	0.56
	2500	370	0.27	488	0.40	592	0.55	682	0.69
	3000	395	0.36	504	0.52	598	0.67	679	0.81
	3500	429	0.49	524	0.67	610	0.83	685	0.97
A18-13ACE	4000	467	0.68	552	0.85	626	1.02	696	1.17
	4500	505	0.88	579	1.06	647	1.25	712	1.44
	3000	309	0.31	415	0.52	497	0.64	570	0.76
	3500	327	0.41	423	0.58	500	0.76	571	0.94
	4000	352	0.58	435	0.73	506	0.92	576	1.13
	4500	377	0.70	448	0.90	514	1.11	582	1.37
A18-18ACE	5000	400	0.90	463	1.10	527	1.38	590	1.54
	5500	427	1.17	483	1.36	541	1.60	599	1.86
	6000	455	1.44	502	1.62	557	1.89	613	2.14
	3000	302	0.28	414	0.47	505	0.61	593	0.82
	3500	315	0.36	418	0.56	503	0.71	585	0.93
	4000	340	0.48	427	0.66	505	0.83	581	1.06

A12 - 12ACE

CFM	STATIC PRESSURE (INCHES: WC)																			
	.25		.50		.75		1.00		1.25		1.50		1.75		2.00		2.25		2.50	
	RPM	HP	RPM	HP	RPM	HP	RPM	HP	RPM	HP	RPM	HP	RPM	HP	RPM	HP	RPM	HP	RPM	HP
1400	409	.11	571	.17	706	.27	823	.37	*	*	*	*	*	*	*	*	*	*	*	*
1600	416	.13	571	.22	701	.32	815	.42	919	.53	*	*	*	*	*	*	*	*	*	*
1800	425	.16	574	.26	699	.36	810	.47	911	.59	*	*	*	*	*	*	*	*	*	*
2000	439	.20	579	.31	700	.42	808	.53	906	.66	997	.78	*	*	*	*	*	*	*	*
2200	457	.25	585	.36	703	.48	808	.60	903	.73	992	.86	*	*	*	*	*	*	*	*
2400	480	.31	594	.42	708	.55	810	.68	903	.81	989	.96	1071	1.10	1149	1.25	*	*	*	*
2600	505	.38	604	.48	714	.62	813	.76	904	.91	989	1.06	1069	1.21	1145	1.37	1217	1.53	1287	1.70
2800	533	.46	618	.56	721	.70	818	.85	907	1.01	990	1.16	1068	1.32	1142	1.49	1213	1.66	1282	1.83
3000	561	.56	635	.65	730	.79	824	.95	911	1.12	993	1.28	1069	1.45	1142	1.62	1211	1.80	1278	1.98
3200	X	X	656	.76	741	.90	831	1.06	917	1.24	996	1.41	1071	1.59	1143	1.77	1211	1.95	1277	2.14
3400	X	X	679	.88	755	1.01	840	1.18	923	1.36	1001	1.55	1075	1.74	1145	1.92	1212	2.11	1277	2.31
3600	X	X	704	1.02	771	1.15	850	1.31	930	1.50	1007	1.70	1080	1.89	1149	2.09	1214	2.29	1278	2.49
3800	X	X	731	1.17	791	1.30	862	1.46	939	1.65	1014	1.85	1085	2.06	1153	2.27	1218	2.48	1280	2.69
4000	X	X	X	X	812	1.46	877	1.62	949	1.82	1021	2.02	1091	2.24	1158	2.46	1222	2.67	1284	2.89



Symbol representation is on the next page.

Specifications are subject to change without notice or obligation

APPENDIX B

Blower Performance Charts



Belt Drive Blowers

A15 – 15ACE

CFM	STATIC PRESSURE (INCHES: WC)																				
	.25		.50		.75		1.00		1.25		1.50		1.75		2.00		2.25		2.50		
	RPM	HP	RPM	HP	RPM	HP	RPM	HP	RPM	HP	RPM	HP	RPM	HP	RPM	HP	RPM	HP	RPM	HP	RPM
2000	341	.14	474	.26	587	.39	686	.53	*	*	*	*	*	*	*	*	*	*	*	*	*
2500	355	.21	476	.34	581	.48	675	.64	760	.81	839	.99	911	1.17	*	*	*	*	*	*	*
3000	376	.31	486	.45	583	.61	670	.78	752	.96	827	1.16	899	1.36	965	1.57	1029	1.78	1089	2.00	
3500	406	.45	501	.59	591	.76	673	.95	750	1.14	822	1.35	890	1.57	955	1.80	1017	2.03	1076	2.27	
4000	441	.63	521	.78	604	.96	681	1.16	754	1.36	822	1.59	887	1.82	949	2.06	1009	2.31	1066	2.56	
4500	X	X	546	1.01	621	1.20	694	1.41	762	1.63	827	1.86	889	2.11	948	2.36	1006	2.62	1061	2.90	
5000	X	X	577	1.30	642	1.49	710	1.71	775	1.95	837	2.19	896	2.45	953	2.72	1007	2.99	●	●	
5500	X	X	612	1.65	668	1.85	729	2.08	790	2.30	849	2.58	906	2.85	961	3.13	●	●	●	●	

A18 – 18ACE

CFM	STATIC PRESSURE (INCHES: WC)																				
	.25		.50		.75		1.00		1.25		1.50		1.75		2.00		2.25		2.50		
	RPM	HP	RPM	HP	RPM	HP	RPM	HP	RPM	HP	RPM	HP	RPM	HP	RPM	HP	RPM	HP	RPM	HP	RPM
3000	299	.25	411	.45	506	.69	588	.93	660	1.19	*	*	*	*	*	*	*	*	*	*	*
3500	310	.32	414	.54	504	.79	584	1.06	656	1.35	724	1.47	785	1.74	*	*	*	*	*	*	*
4000	322	.42	419	.65	505	.91	582	1.21	652	1.52	719	1.66	780	1.95	836	2.25	889	2.55	*	*	*
4500	337	.53	428	.78	509	1.06	582	1.37	650	1.70	714	1.86	775	2.17	831	2.49	884	2.82	935	3.16	3.46
5000	353	.67	439	.93	515	1.23	585	1.55	651	1.89	712	2.09	771	2.41	826	2.75	879	3.10	929	3.46	3.78
5500	369	.84	452	1.12	524	1.43	591	1.76	654	2.12	712	2.35	769	2.69	823	3.04	875	3.41	925	3.78	4.14
6000	387	1.03	466	1.33	535	1.65	599	2.00	659	2.38	715	2.64	769	2.99	822	3.36	872	3.75	921	4.14	4.53
6500	X	X	480	1.58	547	1.92	608	2.28	666	2.67	719	2.97	772	3.34	823	3.72	872	4.12	919	4.53	4.96
7000	X	X	496	1.86	560	2.22	619	2.59	675	2.00	726	3.33	777	3.72	826	4.12	873	4.53	919	4.96	5.43
7500	X	X	513	2.17	575	2.55	631	2.95	685	3.36	735	3.74	783	4.15	831	4.56	876	4.99	921	5.43	5.95
8000	X	X	X	X	590	2.93	645	3.34	696	3.77	745	4.19	792	4.62	837	5.05	881	5.49	925	5.95	6.51
8500	X	X	X	X	605	3.35	659	3.78	709	4.23	756	4.69	801	5.13	845	5.58	888	6.04	930	6.51	7.13
9000	X	X	X	X	622	3.81	674	4.26	722	4.73	768	5.23	812	5.69	855	6.16	896	6.64	937	7.13	★
9500	X	X	X	X	X	X	689	4.79	736	5.28	781	5.81	824	6.30	866	6.79	906	7.29	★	★	★
10000	X	X	X	X	X	X	705	5.37	751	5.88	795	6.45	837	6.96	877	7.47	★	★	★	★	★

A18 – 18ACE, Continued

CFM	STATIC PRESSURE (INCHES: WC)									
	2.75		3.00		3.25		3.50		3.75	
	RPM	HP	RPM	HP	RPM	HP	RPM	HP	RPM	HP
3000	*	*	*	*	*	*	*	*	*	*
3500	*	*	*	*	*	*	*	*	*	*
4000	*	*	*	*	*	*	*	*	*	*
4500	983	3.50	1028	3.85	*	*	*	*	*	*
5000	977	3.82	1023	4.20	1067	4.58	*	*	*	*
5500	972	4.17	1018	4.56	1062	4.96	1104	5.37	1145	5.79
6000	968	4.54	1013	4.95	1057	5.37	1099	5.80	1140	6.24
6500	965	4.95	1009	5.38	1052	5.81	1094	6.26	1135	6.71
7000	964	5.39	1007	5.84	1049	6.29	1090	6.75	1130	7.22
7500	964	5.88	1007	6.34	1048	6.81	1088	7.29	★	★
8000	967	6.41	1008	6.88	1048	7.37	★	★	★	★
8500	971	6.99	1011	7.48	★	★	★	★	★	★
9000	976	7.62	★	★	★	★	★	★	★	★
9500	★	★	★	★	★	★	★	★	★	★
10000	★	★	★	★	★	★	★	★	★	★

THESE SYMBOLS REPRESENT THE FOLLOWING CONDITIONS

- * = Performance is Unstable and Not Recommended
- X = Performance is Below 10% Static Efficiency
- = Exceeds 3 HP
- ★ = Exceeds 7 1/2 HP

NOTE: A18-18ACE Must ship via common carrier.

1725 RPM DRIVE CHART FOR BELT DRIVE BLOWER ASSEMBLIES

Blower Size (All Widths)	DISCHARGE	Motor Location	Motor Pulleys *48 = 1/2 *56 = 3/4	Belt Length												Blower Pulley Size*		
				RPM 845-1132		RPM 697-938		RPM 594-798		RPM 518-698		RPM 458-617		RPM 412-554			RPM 339-457	
				5"		6"		7"		8"		9"		10"			12"	
				Motor Frame		Motor Frame		Motor Frame		Motor Frame		Motor Frame		Motor Frame			Motor Frame	
		48	56	48	56	48	56	48	56	48	56	48	56	48	56			
A9	BH	1	3/4 x *	33	34	35	36	36	37	38	39	40	41					
	BH	2	3/4 x *	35	36	37	38	39	40	40	41	42	43					
	UB	1	3/4 x *	33	34	35	36	37	38	38	40	40	42					
	UB	2	3/4 x *	37	38	39	40	41	42	42	43	44	45					
	TH	1	3/4 x *	36	37	38	39	39	41	41	42	43	44					
	TH	2	3/4 x *	35	36	37	38	38	40	40	41	42	43					
	DB	1	3/4 x *	37	38	38	40	40	41	42	43	44	45					
A10	DB	2	3/4 x *	33	35	35	36	37	38	38	39	40	41					
	BH	1	3/4 x *	35	36	36	37	38	39	40	41	41	43	43	45			
	BH	2	3/4 x *	37	38	39	40	41	42	42	44	44	45	46	47			
	UB	1	3/4 x *	35	36	36	38	38	39	39	41	41	43	43	45			
	UB	2	3/4 x *	39	40	41	42	43	44	45	45	46	47	48	49			
	TH	1	3/4 x *	38	39	40	41	41	43	43	45	45	46	47	48			
	TH	2	3/4 x *	37	38	38	40	40	42	42	43	44	45	45	47			
A12	DB	1	3/4 x *	39	41	40	43	42	44	44	46	46	47	47	49			
	DB	2	3/4 x *	34	36	36	37	38	39	39	41	41	43	43	45			
	BH	1	3/4 x *			38	39	40	42	42	43	44	45	46	47			
	BH	2	3/4 x *			42	43	44	45	45	47	47	49	49	51			
	UB	1	3/4 x *			38	40	40	42	42	44	44	45	45	47			
	UB	2	3/4 x *			44	45	46	47	47	49	49	50	51	52			
	TH	1	3/4 x *			43	44	44	46	46	48	48	49	50	51			
A15	TH	2	3/4 x *			41	42	43	45	45	46	47	48	48	50			
	DB	1	3/4 x *			44	45	46	47	47	49	49	51	50	53			
	DB	2	3/4 x *			38	39	40	42	42	43	44	45	46	47			
	BH	1	3/4 x *			41	42	43	44	45	46	47	47	48	49	52	54	
	BH	2	3/4 x *			44	46	46	48	47	50	49	52	51	53	55	58	
	UB	1	3/4 x *			42	43	44	45	46	47	47	49	49	50	53	54	
	UB	2	3/4 x *			48	49	50	51	51	52	53	55	55	56	59	60	
A18	TH	1	3/4 x *			47	49	49	51	50	53	52	55	54	56	58	59	
	TH	2	3/4 x *			45	47	46	48	48	51	50	52	51	54	56	57	
	DB	1	3/4 x *			47	49	49	51	51	54	53	56	54	57	58	61	
	DB	2	3/4 x *			42	44	43	45	45	48	47	49	48	50	52	54	
	BH	1	3/4 x *										52	53	54	55	58	59
	BH	2	3/4 x *										56	57	58	59	62	63
	UB	1	3/4 x *										49	50	51	52	55	56
A18	UB	2	3/4 x *									52	53	54	55	58	59	
	TH	1	3/4 x *									57	58	59	60	63	64	
	TH	2	3/4 x *									54	55	56	57	60	61	
	DB	1	3/4 x *									58	59	59	60	63	64	
	DB	2	3/4 x *									51	52	53	54	57	58	

All drives listed are for 1725 RPM motors.

BLOWER DISCHARGE AND MOTOR LOCATION



Check out Gates on Page 65 to order popular Pulleys and Belts.

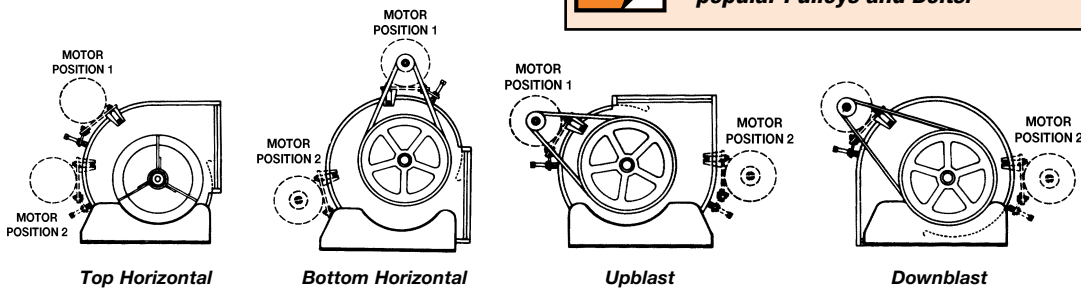
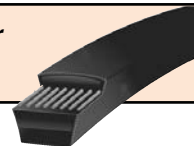

Specifications are subject to change without notice or obligation

APPENDIX B

Dimensional Data



FGP Series Blowers

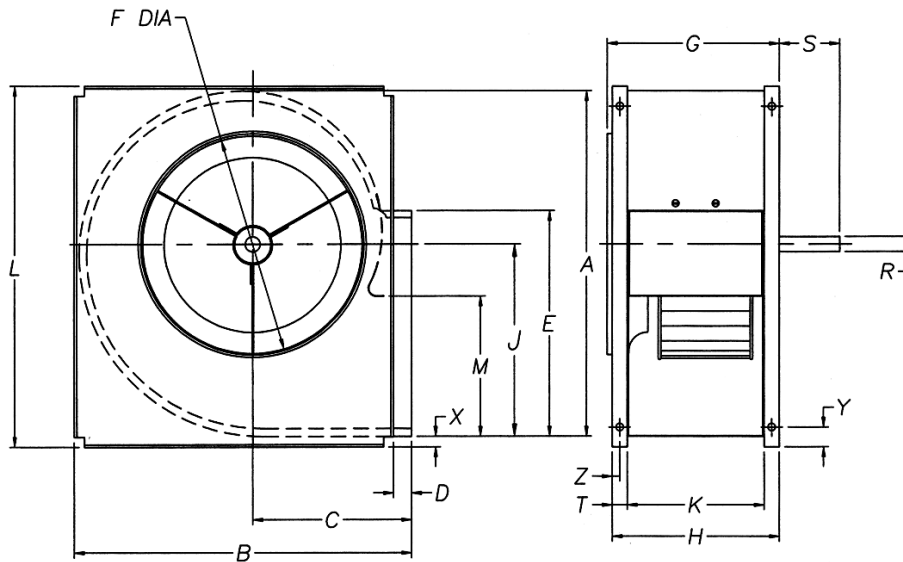

CW ROTATION SHOWN
FGP 10-6A, 12-6A, 15-9A & 18-13A

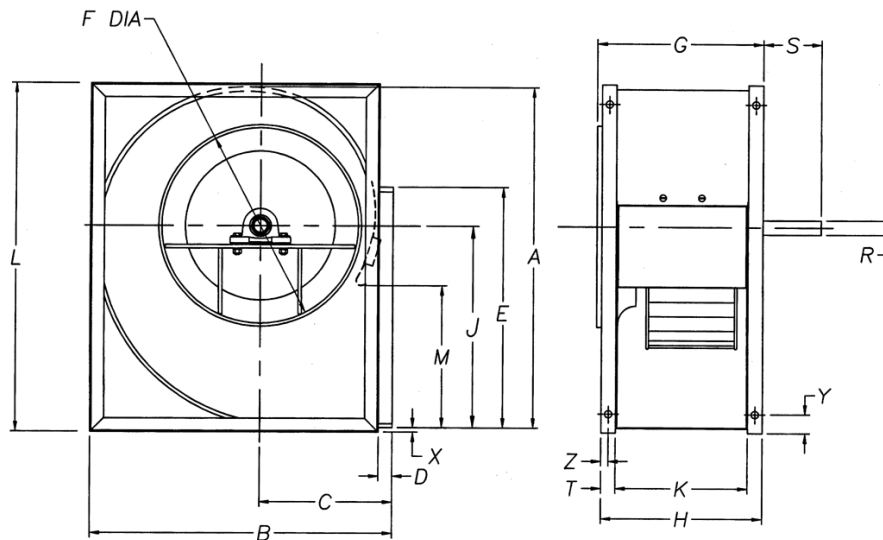

CW ROTATION SHOWN
FGP 22-11K, 25-12K, 27 1/2-14K & 30-15K

Model	A	B	C	D	E	F	G	H	J	K	L	M	R	S	T	X	Y	Z
FGP 10-6A	17.38	16.31	7.94	.69	11.38	9.94	10.31	10.38	9.94	8.25	18.00	6.25	.75	1.94	1.06	.25	.81	.50
FGP 12-6A	20.38	19.25	9.06	.69	13.44	11.94	10.31	10.38	11.75	8.25	21.12	8.38	.75	1.94	1.06	.25	.81	.50
FGP 15-9A	24.25	22.50	10.50	.69	15.88	15.94	14.69	14.62	13.81	12.50	25.00	9.69	1.00	1.94	1.06	.25	.81	.50
FGP 18-13A	29.19	26.88	12.38	.69	18.88	19.94	18.94	18.88	16.56	16.75	30.00	11.75	1.00	3.44	1.06	.25	.81	.50
FGP 22-11K	39.38	35.12	15.69	.62	27.25	21.88	20.19	20.12	23.22	17.12	40.12	14.75	1.19	3.50	1.50	.62	2.50	.75
FGP 25-12K	44.62	39.25	17.25	.62	31.25	25.88	22.69	22.62	26.28	19.62	45.38	17.50	1.19	3.50	1.50	.62	2.50	.75
FGP 27 1/2-14K	49.31	43.50	19.12	.62	34.25	29.88	23.56	23.50	28.91	20.50	50.12	19.88	1.44	5.00	1.50	.62	2.50	.75
FGP 30-15K	53.25	46.75	20.31	.62	36.75	31.88	24.69	24.62	31.22	21.62	54.00	21.75	1.44	5.00	1.50	.62	2.50	.75

Specifications are subject to change without notice or obligation

FGP Series Blowers

FGP 10-6A – CW & CCW

OUT-LET VOL. FPM	VOL. IN CFM	STATIC PRESSURE																							
		.125		.250		.375		.500		.625		.750		.875		1.00		1.25		1.50		1.75		2.00	
		RPM	BHP	RPM	BHP	RPM	BHP	RPM	BHP	RPM	BHP	RPM	BHP	RPM	BHP	RPM	BHP	RPM	BHP	RPM	BHP	RPM	BHP	RPM	BHP
954	600			580	.06	670	.08	747	.09	817	.11	881	.13	944	.14	1003	.16	1118	.20	1230	.24	1344	.28	1458	.32
1113	700	505	.06	612	.08	701	.10	776	.12	844	.14	906	.16	964	.18	1020	.20	1125	.24	1225	.28	1323	.32	1421	.37
1272	800	546	.08	645	.10	731	.13	806	.15	874	.17	934	.20	991	.22	1044	.24	1144	.28	1238	.33	1327	.38	1415	.43
1431	900	590	.10	680	.13	764	.16	837	.19	903	.21	964	.24	1019	.26	1072	.29	1169	.34	1258	.39	1343	.44	1426	.49
1590	1000	636	.14	719	.17	797	.20	869	.23	934	.26	994	.29	1050	.31	1102	.34	1196	.40	1284	.45	1366	.51	1444	.57
1749	1100	684	.18	759	.21	833	.24	902	.27	966	.31	1025	.34	1080	.37	1131	.40	1226	.46	1312	.53	1393	.59	1468	.65
1908	1200	733	.22	802	.26	870	.29	936	.33	998	.36	1056	.40	1111	.44	1162	.47	1256	.54	1342	.61	1421	.67	1495	.74
2967	1300	783	.28	847	.31	911	.35	973	.39	1032	.43	1089	.47	1142	.51	1193	.55	1287	.62	1372	.70	1450	.77	1524	.84
2226	1400	833	.34	893	.38	953	.42	1011	.46	1068	.50	1122	.54	1175	.59	1225	.63	1317	.71	1402	.79	1480	.87		
2385	1500	884	.41	941	.45	996	.49	1051	.54	1105	.58	1158	.63	1208	.67	1257	.72	1349	.81	1433	.90	1510	.98		
2544	1600	936	.49	989	.54	1041	.58	1093	.62	1144	.67	1194	.72	1243	.77	1291	.82	1381	.92	1464	1.01				
2703	1700	988	.59	1038	.63	1087	.68	1136	.72	1185	.77	1233	.82	1279	.88	1325	.93	1413	1.03	1495	1.13				
2862	1800	1040	.69	1088	.74	1135	.78	1181	.83	1227	.89	1272	.94	1317	.99	1361	1.05	1447	1.15						
3021	1900	1092	.81	1138	.85	1183	.90	1227	.96	1270	1.01	1314	1.07	1357	1.12	1399	1.18								
3180	2000	1145	.94	1189	.99	1231	1.04	1273	1.09	1315	1.15	1356	1.20	1397	1.26										

FGP 12-6A – CW & CCW

OUT-LET VOL. FPM	VOL. IN CFM	STATIC PRESSURE																							
		.125		.250		.375		.500		.625		.750		.875		1.00		1.25		1.50		1.75		2.00	
		RPM	BHP	RPM	BHP	RPM	BHP	RPM	BHP	RPM	BHP	RPM	BHP	RPM	BHP	RPM	BHP	RPM	BHP	RPM	BHP	RPM	BHP	RPM	BHP
1081	800	363	0.05	456	0.07	535	0.10	602	0.12	662	0.14	715	0.16	762	0.18	806	0.20	662	0.14	762	0.18	806	0.20	602	0.12
1351	1000	406	0.08	488	0.11	561	0.14	627	0.17	686	0.20	740	0.22	790	0.25	836	0.28	918	0.33	990	0.38	836	0.28	879	0.30
1622	1200	455	0.13	527	0.16	594	0.19	655	0.23	711	0.26	764	0.30	814	0.33	860	0.36	945	0.43	1020	0.49	1089	0.56	1151	0.61
1892	1400	508	0.19	570	0.23	632	0.27	688	0.30	741	0.34	792	0.38	839	0.42	884	0.46	968	0.54	1045	0.62	1116	0.70	1180	0.77
2162	1600	565	0.28	618	0.32	673	0.36	726	0.40	776	0.44	823	0.49	869	0.53	912	0.58	993	0.67	1069	0.76	1139	0.85	1205	0.94
2432	1800	624	0.39	670	0.43	719	0.47	767	0.52	814	0.57	858	0.62	902	0.67	942	0.72	1021	0.82	1095	0.92	1163	1.03	1228	1.13
2703	2000	685	0.52	724	0.56	768	0.61	811	0.66	855	0.72	897	0.77	938	0.82	977	0.88	1052	0.99	1123	1.10	1190	1.22	1253	1.33
2973	2200	746	0.68	781	0.73	819	0.78	859	0.84	899	0.89	939	0.95	977	1.01	1014	1.07	1086	1.19	1154	1.31	1219	1.44		
3243	2400	808	0.88	840	0.93	873	0.98	909	1.04	946	1.10	982	1.16	1019	1.22	1054	1.29	1123	1.42						
3514	2600	871	1.11	899	1.16	930	1.22	962	1.28	996	1.34	1029	1.41	1063	1.47	1096									

FGP 15-9A – CW & CCW

OUT-LET VOL. FPM	VOL. IN CFM	STATIC PRESSURE																							
		.125		.250		.375		.500		.625		.750		.875		1.00		1.25		1.50		1.75		2.00	
		RPM	BHP	RPM	BHP	RPM	BHP	RPM	BHP	RPM	BHP	RPM	BHP	RPM	BHP	RPM	BHP	RPM	BHP	RPM	BHP	RPM	BHP	RPM	BHP
896	1200	298	.07	366	.10	431	.13	499	.17	568	.22	634	.27	692	.33	744	.38	835	.49	914	.60	986	.71	1051	.82
1045	1400	313	.10	384	.13	442	.17	498	.21	557	.25	615	.30	675	.36	731	.42	829	.55	913	.68	988	.80	1056	.93
1194	1600	334	.13	403	.17	460	.21	510	.25	559	.30	609	.35	660	.40	711	.46	814	.60	904	.74	984	.89	1054	1.03
1343	1800	357	.17	423	.22	479	.26	527	.31	571	.36	614	.41	658	.46	703	.52	794	.65	887	.80	971	.97	1047	1.13
1493	2000	380	.22	444	.27	498	.33	545	.38	588	.43	627	.48	666	.53	706	.59	787	.72	869	.87	952	1.03	1032	1.21
1642	2200	404	.27	466	.34	518	.40	564	.46	606	.51	645	.57	681	.63	716	.68	787	.81	862	.95	936	1.11	1010	1.27
1791	2400	430	.34	488	.41	539	.48	584	.54	625	.61	663	.67	699	.73	732	.79	796	.92	862	1.06	930	1.21	998	1.39
1940	2600	456	.42	511	.50	560	.57	604	.64	645	.71	682	.78	717	.85	750	.92	811	1.05	871	1.19	932	1.33	994	1.50
2090	2800	482	.51	534	.60	582	.68	625	.76	665	.83	701	.91	736	.98	768	1.05	829	1.20	885	1.34	940	1.49	997	1.65
2239	3000	509	.61	558	.70	604	.80	647	.88	685	.96	721	1.04	755	1.12	788	1.20	847	1.36	902	1.51	954	1.66	1005	1.82
2388	3200	536	.73	583	.83	627	.93	668	1.02	706	1.11	742	1.20	775	1.28	807	1.37	866	1.53	920	1.70	971	1.86	1019	2.03
2537	3400	564	.86	608	.97	651	1.07	690	1.17	728	1.27	763	1.36	795	1.46	827	1.55	885	1.72	938	1.90	989	2.08		
2687	3600	592	1.01	634	1.12	675	1.23	713	1.34	749	1.45	784	1.55	816	1.64	847	1.74	904	1.93						
2836	3800	621	1.18	661	1.29	699	1.41	736	1.53	772	1.64	805	1.75	837	1.86	867	1.96	924	2.16						
2985	4000	649	1.36	687	1.48	724	1.60	760	1.73	795	1.85	827	1.96	859	2.08	888	2.19								

PERFORMANCE DATA

Performance is based on standard air (.075 lbs./cu. ft.). Operation in shaded area may result in fluctuating pressure. Power rating (BHP) does not include drive losses. Performance shown is for installation Type B-Free inlet, ducted outlet. Performance ratings do not include the effects of appurtenances in the airstream.

Specifications are subject to change without notice or obligation

APPENDIX B

Performance Charts



FGP Series Blowers

FGP 18-13A – CW & CCW

OUT-LET VOL. FPM	VOL. IN CFM	STATIC PRESSURE																							
		.125		.250		.375		.500		.625		.750		.875		1.00		1.25		1.50		1.75		2.00	
		RPM	BHP	RPM	BHP	RPM	BHP	RPM	BHP	RPM	BHP	RPM	BHP	RPM	BHP	RPM	BHP	RPM	BHP	RPM	BHP	RPM	BHP	RPM	BHP
917	2000	285	.14	356	.21	422	.28	479	.36	531	.44	577	.52	620	.60	659	.68	731	.85	796	1.02	856	1.19	912	1.37
1055	2300	306	.20	370	.26	431	.34	487	.43	537	.52	584	.61	626	.70	666	.80	739	.98	804	1.17	864	1.37	919	1.56
1193	2600	331	.26	387	.34	443	.42	496	.51	545	.61	591	.71	633	.81	673	.92	745	1.13	811	1.34	871	1.55	927	1.77
1330	2900	356	.35	407	.43	458	.51	507	.61	554	.71	598	.82	640	.93	680	1.05	752	1.28	818	1.51	878	1.75	934	1.99
1468	3200	383	.45	429	.53	475	.62	521	.72	565	.83	608	.95	648	1.07	687	1.19	759	1.44	824	1.70	885	1.95	941	2.21
1606	3500	410	.57	453	.66	495	.75	537	.86	579	.97	619	1.09	658	1.22	695	1.35	766	1.61	831	1.89	891	2.17	948	2.45
1743	3800	438	.71	478	.81	517	.91	556	1.02	594	1.13	632	1.26	669	1.39	705	1.52	774	1.80	838	2.10	898	2.40	954	2.70
1881	4100	466	.87	504	.98	540	1.09	576	1.20	612	1.32	647	1.45	683	1.58	717	1.72	783	2.01	846	2.32	905	2.64	961	2.96
2018	4400	495	1.06	530	1.18	564	1.29	598	1.41	631	1.53	665	1.66	698	1.80	731	1.94	794	2.25	855	2.57	913	2.90	968	3.24
2156	4700	523	1.28	557	1.40	589	1.52	621	1.64	652	1.77	684	1.91	715	2.05	746	2.19	807	2.51	866	2.84	922	3.18		
2294	5000	553	1.52	584	1.65	615	1.78	645	1.91	674	2.04	704	2.18	733	2.32	763	2.48	821	2.80	877	3.14				
2431	5300	582	1.80	612	1.93	641	2.07	670	2.20	698	2.34	726	2.49	753	2.64	781	2.79	836	3.12						
2569	5600	611	2.10	640	2.25	668	2.39	695	2.53	722	2.68	748	2.83	775	2.98	801	3.14								
2706	5900	641	2.44	669	2.60	695	2.75	721	2.90	746	3.05	772	3.20												
2844	6200	671	2.81	697	2.98	723	3.14																		

FGP 22-11K – CW & CCW

OUT-LET VOL. FPM	VOL. IN CFM	STATIC PRESSURE																							
		.125		.250		.375		.500		.625		.750		.875		1.00		1.25		1.50		1.75		2.00	
		RPM	BHP	RPM	BHP	RPM	BHP	RPM	BHP	RPM	BHP	RPM	BHP	RPM	BHP	RPM	BHP	RPM	BHP	RPM	BHP	RPM	BHP	RPM	BHP
926	3000							338	.40	417	.60	487	.81	550	1.04	607	1.29	659	1.55	708	1.82	797	2.40	871	2.92
1111	3600					309	.45	347	.55	413	.72	480	.95	541	1.20	598	1.46	650	1.74	699	2.03	788	2.65	868	3.32
1296	4200	246	.40	286	.50	324	.60	358	.70	422	.93	478	1.12	535	1.38	589	1.67	641	1.96	689	2.26	779	2.92	859	3.62
1481	4800	271	.56	306	.67	340	.78	373	.90	432	1.16	487	1.41	536	1.63	585	1.89	635	2.21	681	2.54	769	3.22	850	3.96
1667	5400	296	.77	327	.90	358	1.01	389	1.14	444	1.41	496	1.71	545	1.99	589	2.24	630	2.48	676	2.84	761	3.58	841	4.34
1852	6000	326	1.02	350	1.16	379	1.30	407	1.43	460	1.72	507	2.03	554	2.36	598	2.68	638	2.96	676	3.23	757	3.94	833	4.76
2037	6600	349	1.34	375	1.49	400	1.64	426	1.78	476	2.09	522	2.42	565	2.76	607	3.12	647	3.47	685	3.80	755	4.40	828	5.20
2222	7200	376	1.71	400	1.86	422	2.03	447	2.19	494	2.52	538	2.85	575	3.22	619	3.60	657	4.00	694	4.38	764	5.10	826	5.74
2407	7800	404	2.15	422	2.30	447	2.49	469	2.67	512	3.00	555	3.38	595	3.75	632	4.15	669	4.56	704	4.99	772	5.82	835	6.57
2593	8400	432	2.66	451	2.82	472	3.02	492	3.21	533	3.58	573	3.96	611	4.36	648	4.78	682	5.20	716	5.64	782	6.57	844	7.45
2778	9000	460	3.25	478	3.42	497	3.62	516	3.82	554	4.24	591	4.62	629	5.05	663	5.46	698	5.92	730	6.38	793	7.35		
2963	9600	488	3.92	505	4.10	522	4.29	541	4.52	576	4.97	612	5.38	647	5.82	681	6.27	713	6.71	745	7.21				
3148	10200	516	4.67	533	4.87	548	5.05	566	5.30	599	5.78	633	6.23	665	6.66	699	7.15	730	7.63						
3333	10800	544	5.51	560	5.73	575	5.93	591	6.16	623	6.67	655	7.18	686	7.63										

FGP 25-12K – CW & CCW

OUT-LET VOL. FPM	VOL. IN CFM	STATIC PRESSURE																							
		.125		.250		.375		.500		.625		.750		.875		1.00		1.25		1.50		1.75		2.00	
		RPM	BHP	RPM	BHP	RPM	BHP	RPM	BHP	RPM	BHP	RPM	BHP	RPM	BHP	RPM	BHP	RPM	BHP	RPM	BHP	RPM	BHP	RPM	BHP
828	3600					256	.36	295	.48	367	.71	430	1.01	487	1.34	537	1.67	581	2.00	622	2.34	690	3.03	752	3.76
1011	4400					262	.48	297	.60	361	.87	422	1.16	476	1.47	527	1.86	574	2.26	618	2.66	695	3.46	761	4.28
1195	5200			240	.54	272	.64	304	.77	363	1.06	417	1.38	469	1.70	518	2.06	563	2.44	607	2.89	687	3.83	759	4.79
1379	6000	227	.62	262	.77	285	.85	314	.99	368	1.29	419	1.62	466	1.99	511	2.37	556	2.75	598	3.17	676	4.10	749	5.17
1563	6800	248	.86	281	1.03	306	1.16	325	1.25	377	1.58	424	1.93	468	2.31	511	2.71	551	3.15	591	3.57	668	4.48	737	5.47
1747	7600	272	1.15	300	1.34	328	1.53	346	1.64	388	1.94	432	2.30	474	2.69	514	3.11	552	3.56	590	4.04	661	4.98	730	6.00
1931	8400	291	1.51	319	1.70	346	1.92	369	2.11	400	2.35	442	2.75	482	3.15	520	3.58	556	4.05	592	4.53	659	5.57	724	6.62
2115	9200	314	1.94	340	2.16	364	2.39	388	2.62	421	2.94	454	3.26	492	3.70	528	4.14	563	4.61	597	5.12	661	6.17	722	7.32
2299	10000	337	2.46	361	2.69	383	2.91	406	3.19	443	3.61	470	3.90	503	4.32	538	4.80	571	5.28	604	5.78	665	6.87		
2483	10800	361	3.06	383	3.30	404	3.55	425	3.83	464	4.36	491	4.71	516	5.00	549	5.53	581	6.04	611	6.55	671	7.67		
2667	11600	385	3.76	405	4.00	425	4.28	444	4.53	482	5.14	513	5.62	536	5.96	561	6.31	592	6.90						
2851	12400	408	4.56	427	4.80	446	5.10	464	5.38																

PERFORMANCE DATA

Performance is based on standard air (.075 lbs./cu. ft.). Operation in shaded area may result in fluctuating pressure. Power rating (BHP) does not include drive losses. Performance shown is for installation Type B-Free inlet, ducted outlet. Performance ratings do not include the effects of appurtenances in the airstream.

Specifications are subject to change without notice or obligation

FGP Series Blowers

FGP 27½-14K – CW & CCW

OUT-LET VOL. FPM	VOL. IN CFM	STATIC PRESSURE																							
		.125		.250		.375		.500		.625		.750		.875		1.00		1.25		1.50		1.75		2.00	
		RPM	BHP	RPM	BHP	RPM	BHP	RPM	BHP	RPM	BHP	RPM	BHP	RPM	BHP	RPM	BHP	RPM	BHP	RPM	BHP	RPM	BHP	RPM	BHP
826	4000					229	.40	265	.53	333	.83	391	1.17	441	1.53	484	1.90	523	2.29	559	2.70	623	3.48	680	4.39
1033	5000					235	.55	266	.68	324	.99	379	1.34	431	1.76	478	2.17	520	2.62	558	3.08	624	3.97	685	5.08
1240	6000					246	.76	274	.90	325	1.22	374	1.58	420	1.98	465	2.43	509	2.93	549	3.42	620	4.40	684	5.59
1446	7000			234	.88	261	1.04	286	1.19	332	1.52	376	1.89	418	2.31	458	2.77	498	3.23	536	3.77	611	4.83	676	6.10
1653	8000			251	1.18	277	1.38	301	1.56	343	1.91	383	2.30	421	2.72	459	3.20	495	3.69	530	4.22	599	5.37	665	6.64
1860	9000	240	1.32	269	1.56	294	1.80	316	2.01	356	2.41	393	2.82	429	3.25	463	3.72	496	4.24	529	4.78	543	5.86	653	7.16
2066	10000	261	1.76	287	2.02	311	2.28	333	2.53	371	3.00	406	3.44	439	3.89	471	4.37	502	4.89	532	5.42	593	6.60	648	7.90
2273	11000	282	2.29	306	2.56	329	2.86	349	3.14	387	3.67	420	4.17	451	4.64	481	5.15	510	5.68	539	6.23	595	7.50	648	8.75
2479	12000	304	2.92	325	3.20	347	3.53	367	3.84	403	4.44	436	5.00	466	5.54	493	6.04	521	6.61	548	7.18	601	8.39	651	9.72
2686	13000	326	3.66	347	3.96	366	4.30	385	4.65	420	5.32	451	5.94	481	6.54	508	7.11	533	7.66	559	8.26	609	9.50	656	10.86
2893	14000	348	4.54	366	4.84	385	5.19	403	5.58	437	6.30	468	6.99	496	7.65	523	8.30	548	8.91	572	9.51	618	10.66	664	12.15
3099	15000	371	5.54	387	5.84	404	6.21	422	6.62	455	7.40	485	8.18	512	8.91	538	9.59	563	10.28	586	10.93	630	12.21	674	13.66
3306	16000	393	6.69	409	7.00	424	7.37	441	7.78	473	8.64	502	9.48	529	10.27	554	11.04	578	11.76	601	12.50	643	13.80	685	15.31
3512	17000	416	7.99	430	8.30	445	8.68	460	9.10	491	10.03	519	10.90	546	11.78	571	12.61	594	13.41						
3719	18000	439	9.45	452	9.76	466	10.14	480	10.58	510	11.56														

FGP 30-15K – CW & CCW

OUT-LET VOL. FPM	VOL. IN CFM	STATIC PRESSURE																							
		.125		.250		.375		.500		.625		.750		.875		1.00		1.25		1.50		1.75		2.00	
		RPM	BHP	RPM	BHP	RPM	BHP	RPM	BHP	RPM	BHP	RPM	BHP	RPM	BHP	RPM	BHP	RPM	BHP	RPM	BHP	RPM	BHP	RPM	BHP
1058	5800							247	.80	298	1.12	345	1.46	388	1.83	429	2.25	467	2.66	503	3.14	571	4.13	629	5.18
1277	7000							254	1.08	302	1.44	345	1.83	385	2.22	423	2.64	459	3.09	493	3.56	569	4.24	628	5.26
1496	8200					240	1.24	264	1.44	309	1.85	349	2.27	387	2.70	422	3.17	456	3.63	488	4.12	556	4.69	615	5.79
1715	9400					253	1.65	276	1.88	318	2.35	356	2.82	391	3.28	424	3.75	457	4.37	487	4.83	545	5.91	600	7.12
1934	10600			248	1.91	269	2.16	290	2.41	329	2.94	365	3.47	398	3.99	430	4.51	460	5.06	490	5.60	545	6.83	597	8.02
2153	11800	246	2.24	267	2.50	286	2.78	305	3.05	341	3.64	375	4.21	407	4.81	438	5.39	466	5.97	494	6.57	547	7.79	597	9.16
2372	13000	267	2.92	286	3.22	304	3.52	321	3.83	355	4.45	387	5.10	418	5.72	447	6.39	474	7.00	501	7.69	552	9.00	600	10.31
2591	14200	289	3.74	306	4.08	323	4.40	339	4.72	370	5.38	400	6.10	429	6.80	457	7.47	484	8.22	509	8.89	560	10.94	607	12.37
2810	15400	310	4.71	326	5.08	342	5.42	357	5.79	386	6.49	414	7.22	442	8.01	469	8.76	494	9.49	519	10.30	566	11.79	610	13.33
3029	16600	332	5.84	347	6.23	362	6.62	376	6.98	403	7.76	430	8.52	456	9.35	481	10.18	506	11.00	530	11.78	575	13.47	618	15.11
3248	17800	354	7.14	368	7.56	382	7.98	395	8.37	422	9.17														
3467	19000	376	8.61																						

PERFORMANCE DATA

Performance is based on standard air (.075 lbs./cu. ft.). Operation in shaded area may result in fluctuating pressure. Power rating (BHP) does not include drive losses. Performance shown is for installation Type B-Free inlet, ducted outlet. Performance ratings do not include the effects of appurtenances in the airstream.

Call your Customer Service Representative today for more information!!

SHIPPING NOTE:

Most Lau products can be shipped normal parcel shipping services, such as FedEx or UPS, but, some products are too large and must be shipped via common carrier.

Next Day or 2nd Day parcel services can be used to ship items special handling costs. Because the majority of items in this catalog are bulky, we recommend checking with our Customer Service Representatives to verify pricing of expedited service.

APPENDIX B

Drive Charts & Guidelines



FGP Series Blowers

FGP 10-6A

RPM RANGE	MOTOR			PULLEYS			BELT		DRIVE SET NUMBER
				ADJ. MOTOR		BLOWER			
	HP	FRAME	SHAFT I.D.	O.D.	P.D. MIN/MAX	P.D.	TYPE/SIZE	QUANTITY	
483 - 655	¼ - ½	48	½	4.15	2.8 - 3.8	10.00	4L490	1	100
536 - 728	¼ - ½	48	½	4.15	2.8 - 3.8	9.00	4L470	1	101
604 - 819	¼ - ½	48	½	4.15	2.8 - 3.8	8.00	4L460	1	102
690 - 936	¼ - ½	48	½	4.15	2.8 - 3.8	7.00	4L440	1	103
805 - 1092	¼ - ½	48	½	4.15	2.8 - 3.8	6.00	4L420	1	104
966 - 1311	¼ - ½	48	½	4.15	2.8 - 3.8	5.00	4L410	1	105
838 - 1084	½ - ¾	56	⅝	4.75	3.4 - 4.4	7.00	4L460	1	106
977 - 1265	½ - ¾	56	⅝	4.75	3.4 - 4.4	6.00	4L440	1	107
1173 - 1518	½ - ¾	56	⅝	4.75	3.4 - 4.4	5.00	4L420	1	108
977 - 1265	1 - 1½ - 2	143T	⅞	4.75	3.4 - 4.4	6.00	A42	1	109
1173 - 1518	1 - 1½ - 2	143T	⅞	4.75	3.4 - 4.4	5.00	A40	1	110

FGP 12-6A

RPM RANGE	MOTOR			PULLEYS			BELT		DRIVE SET NUMBER
				ADJ. MOTOR		BLOWER			
	HP	FRAME	SHAFT I.D.	O.D.	P.D. MIN/MAX	P.D.	TYPE/SIZE	QUANTITY	
328 - 500	¼ - ½	48	½	3.15	1.9 - 2.9	10.00	4L520	1	111
468 - 714	¼ - ½	48	½	3.15	1.9 - 2.9	7.00	4L470	1	112
609 - 936	¼ - ½	48	½	4.15	2.8 - 3.8	7.00	4L480	1	113
986 - 1232	½ - ¾	56	⅝	5.35	4.0 - 5.0	7.00	A48	1	114
690 - 936	½ - ¾	56	⅝	4.15	2.8 - 3.8	7.00	4L490	1	115
805 - 1095	½ - ¾	56	⅝	4.15	2.8 - 3.8	6.00	4L470	1	116
863 - 1078	1 - 1½ - 2	143T - 145T	⅞	5.35	4.0 - 5.0	8.00	A50	1	117
986 - 1232	1 - 1½ - 2	143T - 145T	⅞	5.35	4.0 - 5.0	7.00	A48	1	118
1150 - 1437	1 - 1½	145T	⅞	5.35	4.0 - 5.0	6.00	A46	1	119

FGP 15-9A

RPM RANGE	MOTOR			PULLEYS			BELT		DRIVE SET NUMBER
				ADJ. MOTOR		BLOWER			
	HP	FRAME	SHAFT I.D.	O.D.	P.D. MIN/MAX	P.D.	TYPE/SIZE	QUANTITY	
298 - 455	¼ - ½	48	½	3.15	1.9 - 2.9	11.00	4L560	1	120
410 - 625	¼ - ½	48	½	3.15	1.9 - 2.9	8.00	4L520	1	121
468 - 652	½ - ¾	56	⅝	3.75	2.4 - 3.4	9.00	4L540	1	122
591 - 838	½ - ¾	56	⅝	3.75	2.4 - 3.4	7.00	4L510	1	123
533 - 690	1 - 1½ - 2	143T - 145T	⅞	4.75	3.4 - 4.4	11.00	A57	1	124
587 - 759	1 - 1½ - 2	143T - 145T	⅞	4.75	3.4 - 4.4	10.00	A56	1	125
733 - 949	1 - 1½ - 2	143T - 145T	⅞	4.75	3.4 - 4.4	8.00	A52	1	126
863 - 1078	1 - 1½ - 2	143T - 145T	⅞	5.35	4.0 - 5.0	8.00	A53	1	127

GENERAL DRIVE GUIDELINES

Pulleys: Use Cast Iron when motor is over 1 HP. Due to variations in pulleys, actual HP and RPM should always be checked to prevent motor overload.

Belts: 4L = FHP Belts
A = A Section Standard Duty
B = B Section
Sets must be length matched

Motors: All motors over 5 HP must be floor mounted.

If Belt Length is not given, motor is to be floor mounted, only. Determine belt length by using the following formula:

$$L = 2C + 1.57(D + d) + \frac{(D - d)^2}{4C}$$

L = Pitch Length of Belt

D = Pitch Dia. of Large Pulley

C = Center Distance

d = Pitch Dia. Small Pulley

Specifications are subject to change without notice or obligation

FGP Series Blowers

FGP 18-13A

RPM RANGE	MOTOR			PULLEYS			BELT		DRIVE SET NUMBER
				ADJ. MOTOR		BLOWER P.D.			
	HP	FRAME	SHAFT I.D.	O.D.	P.D. MIN/MAX		TYPE/SIZE	QUANTITY	
273 - 417	¼ - ⅓	48	½	3.15	1.9 - 2.9	12.00	4L650	1	128
328 - 500	¼ - ⅓	48	½	3.15	1.9 - 2.9	10.00	4L610	1	129
328 - 500	½ - ¾	56	¾	3.15	1.9 - 2.9	10.00	4L620	1	130
376 - 546	½ - ¾	56	¾	3.75	2.4 - 3.4	11.00	4L640	1	131
518 - 733	½ - ¾	56	¾	3.75	2.4 - 3.4	8.00	4L590	1	132
451 - 584	1 - 1½ - 2	143T - 145T	⅞	4.75	3.4 - 4.4	13.00	A67	1	133
533 - 690	1 - 1½ - 2	143T - 145T	⅞	4.75	3.4 - 4.4	11.00	A63	1	134
652 - 843	1 - 1½ - 2	143T - 145T	⅞	4.75	3.4 - 4.4	9.00	A60	1	135
767 - 958	1 - 1½ - 2	143T - 145T	⅞	5.35	4.0 - 5.0	9.00	A61	1	136
627 - 784	3	182T	1⅞	5.35	4.0 - 5.0	11.00	A65	1	137
767 - 958	3	182T	1⅞	5.35	4.0 - 5.0	9.00	A62	1	138

FGP 22-11K

RPM RANGE	MOTOR			PULLEYS			BELT		DRIVE SET NUMBER
				ADJ. MOTOR		BLOWER P.D.			
	HP	FRAME	SHAFT I.D.	O.D.	P.D. MIN/MAX		TYPE/SIZE	QUANTITY	
182 - 278	½ - ¾	56	⅝	3.15	1.9 - 2.9	18.00	A85	1	139
152 - 385	½ - ¾	56	⅝	3.15	1.9 - 2.9	13.00	A76	1	140
345 - 489	½ - ¾	56	⅝	3.75	2.4 - 3.4	12.00	A74	1	141
326 - 422	1 - 1½ - 2	143T - 145T	⅞	4.75	3.4 - 4.4	18.00	A87	1	142
419 - 542	1 - 1½ - 2	143T - 145T	⅞	4.75	3.4 - 4.4	14.00	A80	1	143
533 - 690	1 - 1½ - 2	143T - 145T	⅞	4.75	3.4 - 4.4	11.00	A74	1	144
383 - 479	3	182T	1⅞	5.35	4.0 - 5.0	18.00	A88	1	145
460 - 575	3	182T	1⅞	5.35	4.0 - 5.0	15.00	A83	1	146
575 - 719	3	182T	1⅞	5.35	4.0 - 5.0	12.00	A78	1	147
690 - 863	3	182T	1⅞	5.35	4.0 - 5.0	10.00	A74	1	148
460 - 575	5	184T	1⅞	5.35	4.0 - 5.0	15.00	A83	2	149
575 - 719	5	184T	1⅞	5.35	4.0 - 5.0	12.00	A78	2	150
690 - 863	5	184T	1⅞	5.35	4.0 - 5.0	10.00	A74	2	151
544 - 708	7½	213T	1⅞	6.00	4.3 - 5.5	13.40	B—	2	152
713 - 912	7½	213T	1⅞	6.00	4.3 - 5.5	10.40	B—	2	153
529 - 644	7½	213T	1⅞	5.95	4.6 - 5.6	15.00	A—	2	154
610 - 743	7½	213T	1⅞	5.95	4.6 - 5.6	13.00	A—	2	155

FGP 25-12K

RPM RANGE	MOTOR			PULLEYS			BELT		DRIVE SET NUMBER
				ADJ. MOTOR		BLOWER P.D.			
	HP	FRAME	SHAFT I.D.	O.D.	P.D. MIN/MAX		TYPE/SIZE	QUANTITY	
225 - 300	½ - ¾	56	⅝	3.25	2.4 - 3.2	18.40	B92	1	156
269 - 358	½ - ¾	56	⅝	3.25	2.4 - 3.2	15.40	B87	1	157
290 - 384	1 - 1½ - 2	143T - 145T	⅞	4.15	3.1 - 4.1	18.40	B93	1	158
347 - 440	1 - 1½ - 2	143T - 145T	⅞	4.75	3.7 - 4.7	18.40	B94	1	159
415 - 526	1 - 1½ - 2	143T - 145T	⅞	4.75	3.7 - 4.7	15.40	B88	1	160
476 - 605	1 - 1½ - 2	143T - 145T	⅞	4.75	3.7 - 4.7	13.40	B85	1	161
234 - 309	1 - 1½ - 2	143T - 145T	⅞	3.35	2.5 - 3.3	18.40	B92	2	162
319 - 405	3	182T	1⅞	4.75	3.7 - 4.7	20.00	B97	1	163
347 - 440	3	182T	1⅞	4.75	3.7 - 4.7	18.40	B94	1	164
403 - 496	3	182T	1⅞	5.35	4.3 - 5.3	18.40	B95	1	165
482 - 594	3	182T	1⅞	5.35	4.3 - 5.3	15.40	B90	1	166
554 - 682	3	182T	1⅞	5.35	4.3 - 5.3	13.40	B86	1	167
347 - 440	5	184T	1⅞	4.75	3.7 - 4.7	18.40	B94	2	168
403 - 496	5	184T	1⅞	5.35	4.3 - 5.3	18.40	B95	2	169
482 - 594	5	184T	1⅞	5.35	4.3 - 5.3	15.40	B90	2	170
554 - 682	5	184T	1⅞	5.35	4.3 - 5.3	13.40	B86	2	171
650 - 800	5	184T	1⅞	5.35	4.3 - 5.3	11.40	B83	2	172
616 - 728	7½	213T	1⅞	6.55	5.5 - 6.5	15.40	A—	2	173
529 - 644	7½	213T	1⅞	5.95	4.6 - 5.6	15.00	A—	2	174
414 - 518	7½	213T	1⅞	6.50	4.8 - 6.0	20.00	B—	2	175

Specifications are subject to change without notice or obligation

APPENDIX B

Drive Charts



FGP Series Blowers

FGP 27½-14K

RPM RANGE	MOTOR			PULLEYS			BELT		DRIVE SET NUMBER
				ADJ. MOTOR		BLOWER P.D.			
	HP	FRAME	SHAFT I.D.	O.D.	P.D. MIN/MAX		TYPE/SIZE	QUANTITY	
225 - 300	½ - ¾	56	¾	3.25	2.4 - 3.2	18.40	B98	1	176
234 - 309	1 - 1½ - 2	143T - 145T	¾	3.35	2.5 - 3.3	18.40	B98	2	177
272 - 366	1 - 1½ - 2	143T - 145T	¾	3.95	2.9 - 3.9	18.40	B99	2	178
347 - 440	1 - 1½ - 2	143T - 145T	¾	4.75	3.7 - 4.7	18.40	B100	1	179
272 - 366	3	182T	1½	3.95	2.9 - 3.9	18.40	B99	2	180
347 - 440	3	182T	1½	4.75	3.7 - 4.7	18.40	B100	2	181
403 - 496	3	182T	1½	5.35	4.3 - 5.3	18.40	B100	1	182
304 - 496	5	184T	1½	5.35	4.3 - 5.3	18.40	B100	2	183
482 - 594	5	184T	1½	5.35	4.3 - 5.3	15.40	B96	2	184
331 - 414	7½	213T	1¾	6.50	4.8 - 6.0	25.00	B—	2	185
403 - 515	7½	213T	1¾	6.00	4.3 - 5.5	18.40	B—	2	186
459 - 559	7½	213T	1¾	5.95	4.9 - 5.9	18.40	B—	2	187
549 - 661	7½	213T	1¾	5.95	4.9 - 5.9	15.40	B—	2	188
422 - 509	10	215T	1¾	5.95	4.9 - 5.9	20.00	B—	2	189
474 - 560	10	215T	1¾	6.55	5.5 - 6.5	20.00	B—	2	190
515 - 609	10	215T	1¾	6.55	5.5 - 6.5	18.40	B—	2	191
616 - 728	10	215T	1¾	6.55	5.5 - 6.5	15.40	B—	2	193
507	15	254T	1¾	6.15	5.8	20.00	B—	3	194
542	15	254T	1¾	6.55	6.2	20.00	B—	3	195
562	15	254T	1¾	6.35	6.0	18.40	B—	3	196
581	15	254T	1¾	6.55	6.2	18.40	B—	3	197
600	15	254T	1¾	6.75	6.4	18.40	B—	3	198
619	15	254T	1¾	6.95	6.6	18.40	B—	3	199
637	15	254T	1¾	7.15	6.8	18.40	B—	3	200
656	15	254T	1¾	7.35	7.0	18.40	B—	3	201
665	15	254T	1¾	7.35	7.0	18.40	B—	3	202
672	15	254T	1¾	6.35	6.0	15.40	B—	3	203
694	15	254T	1¾	6.55	6.2	15.40	B—	3	204

FGP 30-15K

RPM RANGE	MOTOR			PULLEYS			BELT		DRIVE SET NUMBER
				ADJ. MOTOR		BLOWER P.D.			
	HP	FRAME	SHAFT I.D.	O.D.	P.D. MIN/MAX		TYPE/SIZE	QUANTITY	
234 - 309	1 - 1½ - 2	143T - 145T	¾	3.35	2.5 - 3.3	18.40	B103	2	205
272 - 366	1 - 1½ - 2	143T - 145T	¾	3.95	2.9 - 3.9	18.40	B116	2	206
200 - 269	3	182T	1½	3.95	2.9 - 3.9	25.00	B103	2	207
272 - 366	3	182T	1½	3.95	2.9 - 3.9	18.40	B103	2	208
347 - 440	3	182T	1½	4.75	3.7 - 4.7	18.40	B105	2	209
272 - 366	5	184T	1½	3.95	2.9 - 3.9	18.40	B103	2	210
347 - 440	5	184T	1½	4.75	3.7 - 4.7	18.40	B105	2	211
403 - 496	5	184T	1½	5.35	4.3 - 5.3	18.40	B105	2	212
297 - 366	7½ - 10	213T	1¾	6.00	4.3 - 5.5	25.00	B—	2	213
371 - 474	7½ - 10	213T	1¾	6.00	4.3 - 5.5	20.00	B—	2	214
422 - 509	7½ - 10	213T	1¾	5.95	4.9 - 5.9	20.00	B—	2	215
515 - 609	7½ - 10	213T	1¾	6.55	5.5 - 6.5	18.40	B—	2	216
507	15	254T	1¾	6.15	5.8	20.00	B—	3	217
526	15	254T	1¾	6.35	6.0	20.00	B—	3	218
562	15	254T	1¾	6.35	6.0	18.40	B—	3	219
581	15	254T	1¾	6.55	6.2	18.40	B—	3	220
600	15	254T	1¾	6.75	6.4	18.40	B—	3	221
619	15	254T	1¾	6.95	6.6	18.40	B—	3	222

Specifications are subject to change without notice or obligation

Dynamic & Static Curtain Type Fire Dampers

During the life of a building, testing and maintenance of all life safety products is essential. The interval of testing and maintenance varies widely depending on the duration of system operation, condition of fresh air, amount of dust in return air, and other factors. The intervals specified in this standard are intended to be the maximum and should be shortened if system conditions warrant. To ensure that fire dampers will perform as intended under fire conditions, proper maintenance should include testing of all dampers every two years as a minimum. (NFPA 90A)

MAINTENANCE

- Holding up the blade package, unhook the fuse link and allow the blades to evenly drop.
- Check the damper for rust and make sure there is no blockage in the path of travel for the blade package.
- Clean damper blades and other working parts in the airstream.
- Push the blade package back to the top of damper and reconnect the fuse link.

TESTING DAMPERS

To test dampers perform the following tests **under normal operating conditions and at an ambient temperature of 50-104°F.**

- First perform above maintenance.
- Use a moderate heat source, heat the fuse link until it melts. **(CAUTION! Keep fingers & hands out of blade package travel path.)**
- Check the blades to make sure they completely closed.
- On dynamic fire dampers make sure the blades close completely and stay locked in the blade catches.
- Push the blade package back to the top of damper and connect a new fuse link.

Smoke Dampers

CSD36, CSD37 & CSDRS25

During the life of a building, maintenance is essential. To ensure that the smoke-control system will perform as intended under fire and smoke conditions, proper maintenance of the system should include; periodic testing of all equipment such as initiating devices, fans, dampers, controls, doors, and windows. Lau recommends each smoke damper be cycled and tested every 6 months in accordance with NFPA 92A. According to the NFPA 92A periodic testing is defined as semi-annually for dedicated systems and annually for non-dedicated systems. To test dampers perform the following tests **under normal airflow and at an ambient temperature of 50-104°F.**

- Examine the damper to ensure it is not rusted or blocked.
- Clean damper blades and other working parts that are in the airstream.
- Lubricate tie-bar linkage and jackshaft bearings with a silicone lubricant.
- Supply power to the actuator.
- Once the actuator is in the holding position, the power should then be turned off to the actuator.
- Check the blades to make sure they completely closed.
- Supply power to the actuator again.
- Check blades to make sure they completely opened.
- Repeat these steps for three complete cycles.

Fire/Smoke Dampers

CFS1 & CFS2

During the life of a building, maintenance is essential. To ensure that the smoke-control system will perform as intended under fire conditions. Proper maintenance of the system should include periodic testing of all equipment such as initiating devices, fans, dampers, controls, doors, and windows. Lau recommends each smoke damper be cycled and tested every 6 months in accordance with NFPA 92A. According to the NFPA 92A periodic testing is defined as semi-annually for dedicated systems and annually for non-dedicated systems. To test dampers perform the following tests **under normal airflow and at an ambient temperature of 50-104°F.**

- Examine the damper to ensure it is not rusted or blocked.
- Clean damper blades and other working parts in the airstream.
- Lubricate tie-bar linkage, jackshaft bearings and over-center link arm pivots with a silicone lubricant.
- Supply power to the actuator.
- Once the actuator is in the holding position, the power should then be turned off to the actuator.
- Check the blades to make sure they completely closed.
- Supply power to the actuator again.
- Check blades to make sure they completely open.
- Repeat these steps for three complete cycles.
- Use a moderate heat source, heat up the silver thermal disc found on the “in air-stream” side of the TS-150 or EFL.

(CAUTION! Prolonged exposure to extreme heat or using a form of heat that is too hot can permanently damage the device.)

- The disc will dimple inward causing the flow of electricity through the box to be broken and the blades close.
- Once the disc cools down, press (gently) the manual reset button until you feel the disc return to its normal position causing the damper blades to then return to normal holding position.



1. The actuator manufacturer's recommended maintenance procedure should be followed for cycle frequency. This may differ from the maintenance frequency of the damper.

Specifications are subject to change without notice or obligation

APPENDIX D



OEM Cross Reference

OEM Name	OEM Part Number	Blade Count	Dia.	Pitch	Rot.	Lau Part Number	Lau Pitch
AAON	P01330	4	24"	24°	CCW	60804401	23°
AAON	P13740	4	22"	33°	CW	60559501	33°
AAON	P14170	4	24"	33°	CW	60559901	33°
AAON	P14260	4	24"	28°	CW	60559701	27°
AAON	P26400	4	22"	26°	CW	60559301	27°
AAON	P26400	4	22"	26°	CW	60559301	27°
AAON	27042	3	22"	30°	CW	60557301	27°
Addison	0516N-0021A	4	24"	36°	CW	60559901	33°
Addison	0516N-0022A	4	24"	22°	CCW	60804401	23°
Addison	5151N-0214A	5	22"	30°	CCW	60561401	27°
Addison	0516N-0027A	3	24"	25°	CCW	60557801	27°
Advanced Coil Technology	1484-FAB	4	20"	36°	CCW	60559201	33°
Advanced Coil Technology	L-2036	4	20"	36°	CCW	60559201	33°
Advanced Coil Technology	PRTO-2	3	24"	24°	CW	60557701	27°
Advantage Engineering	2996009	4	22"	30°	CCW	60559401	27°
AEC, Inc	A0562464	5	18"	30°	CCW	60561201	33°
AEC, Inc	A0533815	5	26"	30°	CW	60761301	27°
AGCO Corporation	700714681	3	12"	18°	CCW	60716201	19°
AGCO Corporation	250937M93	3	12"	18°	CCW	60716201	19°
AGCO Corporation	10A27121	2	18"	33°	CCW	60652101	33°
AGCO Corporation	168824A	2	18"	36°	CCW	60652101	33°
AGCO Corporation	70254349	2	22"	25°	CCW	60814201	27°
Airtherm	52500028	3	10"	24°	CW	60265201	27°
Airtherm	52500057	3	18"	27°	CW	60556101	27°
Airtherm	52500015	3	18"	29°	CW	60556301	30°
Airtherm	52500056	3	18"	33°	CW	60556501	33°
Airtherm	52500019	3	20"	30°	CW	60556901	30°
Airtherm	52500020	3	24"	24°	CW	60557701	27°
Airtherm	52500021	3	24"	27°	CW	60557701	27°
Airtherm	52500063	3	12"	24°	CW	60716301	23°
Airtherm	52500023	3	12"	24°	CW	60716301	23°
Airtherm	52500027	3	14"	24°	CW	60716501	23°
Airtherm	52500009	3	16"	23°	CW	60717101	23°
Allied Air	41141-001	4	18"	26°	CW	60558101	27°
Allied Air	41518-001	4	20"	26°	CW	60558701	27°
Allied Air	39294B001	3	18"	24°	CW	60556101	27°

While Lau makes every effort to provide accurate and complete information, the recommended propeller replacement is the closest match to Lau stock products. It is up to the individual purchaser to double-check performance to guarantee the correct propeller application. Lau reserves the right to make changes to this catalog, at any time and without notice, to prices, specifications and models and is not responsible for typographical or image errors.

OEM Name	OEM Part Number	Blade Count	Dia.	Pitch	Rot.	Lau Part Number	Lau Pitch
Amana Refrigeration	10625716	3	18"	26°	CW	60556101	27°
Amana Refrigeration	10625703	3	18"	28°	CW	60556101	27°
Amana Refrigeration	10625726	3	18"	28°	CCW	60556201	27°
Amana Refrigeration	10625728	3	18"	28°	CCW	60556201	27°
Amana Refrigeration	10625729	3	18"	29°	CCW	60556401	30°
Amana Refrigeration	10625721	3	18"	33°	CW	60556501	33°
Amana Refrigeration	10625704	3	22"	28°	CW	60557301	27°
Amana Refrigeration	10625722	3	22"	29°	CW	60557301	27°
Amana Refrigeration	10625723	3	22"	33°	CW	60557501	33°
Amana Refrigeration	10625706	3	22"	33°	CW	60557501	33°
Amana Refrigeration	10625727	2	18"	27°	CCW	60772501	28°
American Industrial Heat Trans	307-0002	4	10"	27°	CW	60717701	27°
American Industrial Heat Trans	307-0038	4	20"	26°	CCW	60558801	27°
American Industrial Heat Trans	307-0038	4	20"	26°	CW	60558701	27°
American Industrial Heat Trans	307-0011	3	22"	28°	CW	60557301	27°
American Industrial Heat Trans	307-0012	3	22"	35°	CW	60557501	33°
American Standard	38010396-001	4	26"	32°	CW	60761101	33°
Aqua Cal	3030	4	20"	25°	CW	60800401	23°
Aqua Cal	3102	3	24"	24°	CW	60557701	27°
Aqua Cal	3104	4	24"	32°	CW	60559901	33°
Armstrong	39294B001	3	18"	24°	CW	60556101	27°
Armstrong	37373B001	4	20"	25°	CW	60800401	23°
Armstrong	821.01	4	10"	35°	CW	60759901	33°
Armstrong	821.014	4	14"	34°	CW	60760301	33°
Armstrong	821.016	4	16"	30°	CW	60719501	27°
Armstrong	37373B001	4	20"	25°	CW	60800401	23°
Armstrong	37373B001/S	4	20"	25°	CW	60800401	23°
Armstrong	41141-001	4	18"	26°	CW	60558101	27°
Armstrong	41518-001	4	20"	26°	CW	60558701	27°
Armstrong	C-8002-10	4	10"	35°	CW	60759901	33°
Armstrong	C-8002-14	4	14"	34°	CW	60760301	33°
Armstrong	C-8002-16	4	16"	30°	CW	60719501	27°
Armstrong	C-8002-5	4	24"	32°	CW	60559901	33°
Armstrong	C-8002-18	5	18"	25°	CW	60560501	27°
Armstrong	C-8002-24	5	24"	35°	CW	60561901	33°
Armstrong	821.024	5	24"	35°	CW	60561901	33°

While Lau makes every effort to provide accurate and complete information, the recommended propeller replacement is the closest match to Lau stock products. It is up to the individual purchaser to double-check performance to guarantee the correct propeller application. Lau reserves the right to make changes to this catalog, at any time and without notice, to prices, specifications and models and is not responsible for typographical or image errors.

APPENDIX D



OEM Cross Reference

OEM Name	OEM Part Number	Blade Count	Dia.	Pitch	Rot.	Lau Part Number	Lau Pitch
Bally Refrigerated Boxes	016715	4	18"	27°	CW	60558101	27°
Bally Refrigerated Boxes	017520	4	18"	27°	CW	60558101	27°
Bally Refrigerated Boxes	056827	4	18"	25°	CCW	60800301	23°
Baltimore Aircoil Coil	251032	4	20"	36°	CW	60559101	33°
Baltimore Aircoil Coil	251033	3	20"	30°	CW	60556901	30°
Baltimore Aircoil Coil	251034	3	20"	32°	CW	60557101	33°
Baltimore Aircoil Coil	251035	3	24"	24°	CW	60557701	27°
Baltimore Aircoil Coil	251036	3	24"	28°	CW	60557701	27°
Baltimore Aircoil Coil	251037	3	24"	30°	CW	60557901	33°
Bard Manufacturing	5151-046	3	18"	27°	CW	60556101	27°
Bard Manufacturing	5151-033	3	18"	29°	CCW	60556401	30°
Bard Manufacturing	5151-007	3	20"	26°	CW	60556701	27°
Bard Manufacturing	5151-057	3	24"	26°	CW	60557701	27°
Bard Manufacturing	5151-030	3	24"	28°	CCW	60557801	27°
Bard Manufacturing	5151-036	3	24"	28°	CCW	60557801	27°
Bard Manufacturing	5151-025	4	20"	27°	CW	60558701	27°
Bard Manufacturing	5151-032	4	20"	22°	CCW	60800501	23°
Bard Manufacturing	5151-045	4	20"	22°	CW	60800401	23°
Bard Manufacturing	5151-050	4	20"	22°	CCW	60800501	23°
Bard Manufacturing	5151-028	5	20"	28°	CW	60560901	27°
Bard Manufacturing	5151-024	5	18"	34°	CCW	60561201	33°
Bard Manufacturing	5151-026	4	24"	25°	CCW	60804401	23°
Big Dutchman	60-00-0007	4	18"	22°	CW	60800201	23°
Blanchard-Ness or Hussman	F0102800	4	20"	34°	CW	60559101	33°
Breidert Air Products	1266.1025	4	10"	25°	CW	60717701	27°
Breidert Air Products	1266.1033	4	10"	33°	CW	60759901	33°
Breidert Air Products	1266.1425	4	14"	25°	CW	60718701	23°
Breidert Air Products	1266.1430	4	14"	30°	CW	60718901	27°
Breidert Air Products	1266.1435	4	14"	35°	CW	60760301	33°
Breidert Air Products	1266.1625	4	16"	25°	CW	60719301	23°
Breidert Air Products	092156610	4	10"	35°	CCW	60760001	33°
Breidert Air Products	092158410	4	12"	36°	CCW	60760201	33°
Breidert Air Products	92159510	4	16"	30°	CCW	60719601	27°
Breidert Air Products	1266.1825	3	18"	25°	CW	60556101	27°
Breidert Air Products	1266.1834	3	18"	34°	CW	60556501	33°
Breidert Air Products	1266.2030	3	20"	30°	CW	60556901	30°

While Lau makes every effort to provide accurate and complete information, the recommended propeller replacement is the closest match to Lau stock products. It is up to the individual purchaser to double-check performance to guarantee the correct propeller application. Lau reserves the right to make changes to this catalog, at any time and without notice, to prices, specifications and models and is not responsible for typographical or image errors.

OEM Name	OEM Part Number	Blade Count	Dia.	Pitch	Rot.	Lau Part Number	Lau Pitch
Breidert Air Products	1266.1235	4	12"	35°	CW	60760101	33°
Breidert Air Products	92159510	4	16"	30°	CW	60719501	27°
Breidert Air Products	1266.1831	3	18"	31°	CW	60556301	30°
Breidert Air Products	1266.2025	3	20"	25°	CW	60556701	27°
Canarm	P3011-E20R	3	20"	26°	CW	60556701	27°
Canarm	P3000-20D20	3	20"	30°	CW	60556901	30°
Canarm	P3011-E24R	3	24"	24°	CW	60557701	27°
Canarm	P3011-24G	3	24"	26°	CW	60557701	27°
Canarm	MEXICO	3	24"	34°	CW	60557901	33°
Canarm	P3011-24G1	3	24"	34°	CW	60557901	33°
Canarm	P3000-16D24	3	16"	22°	CW	60717101	23°
Canarm	P3014-C16R	3	16"	24°	CW	60717101	23°
Canarm	P3011-24	3	24"	26°	CW	60557701	27°
Canarm	P3014-C16R	3	16"	24°	CW	60717101	23°
Canatal International	50600003	4	18"	26°	CW	60558101	27°
Canatal International	50600005	4	18"	30°	CW	60558301	30°
Canatal International	50600007	3	18"	30°	CW	60556301	30°
Cancoil Thermal	FA1001	4	24"	26°	CW	60559701	27°
Cancoil Thermal	FA1007	4	20"	32°	CW	60559101	33°
Cancoil Thermal	FA1016	5	24"	27°	CW	60561701	27°
Captive-Aire Systems	34180000	4	18"	36°	CCW	60558601	33°
Captive-Aire Systems	34DDA	3	20"	30°	CCW	60557001	30°
Captive-Aire Systems	3424RPRP	3	24"	24°	CW	60557701	27°
Carnes	998-4822	4	12"	35°	CW	60760101	33°
Carnes	999-5744	4	18"	33°	CW	60558501	33°
Carnes	998-4825	3	18"	36°	CW	60556501	33°
Carnes	998-4827	3	20"	26°	CW	60556701	27°
Carrier	LA01LA024	3	24"	32°	CW	60557901	33°
Carrier	1080763	4	20"	36°	CW	60559101	33°
Carrier	2325270	4	20"	35°	CCW	60559201	33°
Carrier	2325501	4	22"	31°	CCW	60559601	33°
Carrier	08221020	4	16"	22°	CW	60719301	23°
Carrier	08221022	4	18"	34°	CW	60558501	33°
Carrier	08221023	4	22"	28°	CW	60559301	27°
Carrier	08221047	4	26"	29°	CW	60760901	27°
Carrier	08221076	4	18"	34°	CW	60558501	33°

While Lau makes every effort to provide accurate and complete information, the recommended propeller replacement is the closest match to Lau stock products. It is up to the individual purchaser to double-check performance to guarantee the correct propeller application. Lau reserves the right to make changes to this catalog, at any time and without notice, to prices, specifications and models and is not responsible for typographical or image errors.

APPENDIX D



OEM Cross Reference

OEM Name	OEM Part Number	Blade Count	Dia.	Pitch	Rot.	Lau Part Number	Lau Pitch
Carrier	22311121	4	12"	24°	CCW	60718201	23°
Carrier	22311221	4	22"	29°	CW	60559301	27°
Carrier	213155000	4	24"	29°	CW	60559701	27°
Carrier	213156000	4	20"	29°	CW	60558901	30°
Carrier	214100000	4	14"	32°	CW	60760301	33°
Carrier	214100001	4	14"	32°	CW	60760301	33°
Carrier	214114000	4	24"	28°	CW	60559701	27°
Carrier	213155-000	4	24"	29°	CW	60559701	27°
Carrier	213156-000	4	20"	29°	CW	60558901	30°
Carrier	214114-000	4	24"	28°	CW	60559701	27°
Carrier	38-00509-00	4	18"	23°	CW	60800201	23°
Carrier	401-100	4	10"	35°	CCW	60760001	33°
Carrier	AC401-100	4	10"	35°	CCW	60760001	33°
Carrier	LA01AA102	4	10"	30°	CW	60759901	33°
Carrier	LA01AH243	4	24"	24°	CCW	60804401	23°
Carrier	LA01EW024	4	24"	22°	CW	60804301	23°
Carrier	LA01LA180	4	18"	25°	CW	60800201	23°
Carrier	LA680544	4	16"	31°	CW	60760501	33°
Carrier	38-00511-00Z	5	16"	25°	CCW	60560201	27°
Carrier	LA680517	5	18"	29°	CCW	60560601	27°
Carrier	38-00510-00Z	5	17½"	25°	CCW	60560601	27°
Carrier	20-25-0854	5	18"	25°	CCW	60560601	27°
Carrier	LA01AA179	5	18"	34°	CW	60560701	33°
Carrier	LA680518	5	20"	25°	CCW	60561001	27°
Carrier	LA01AU183	5	18"	30°	CCW	60561201	33°
Carrier	LA680540	5	22"	34°	CW	60561501	33°
Carrier	LA680538	5	24"	28°	CW	60561701	27°
Carrier	521125	5	24"	26°	CCW	60561801	27°
Carrier	2325509	5	26"	30°	CW	60761301	27°
Carrier	08221150	5	26"	32°	CW	60761501	33°
Carrier	LA01AA177	3	18"	26°	CW	60556101	27°
Carrier	1068920	3	18"	26°	CW	60556101	27°
Carrier	LA680537	3	18"	28°	CW	60556101	27°
Carrier	LA680549	3	18"	28°	CW	60556101	27°
Carrier	1085958	3	18"	28°	CW	60556101	27°
Carrier	LA01LB018	3	18"	25°	CCW	60556201	27°

While Lau makes every effort to provide accurate and complete information, the recommended propeller replacement is the closest match to Lau stock products. It is up to the individual purchaser to double-check performance to guarantee the correct propeller application. Lau reserves the right to make changes to this catalog, at any time and without notice, to prices, specifications and models and is not responsible for typographical or image errors.

OEM Name	OEM Part Number	Blade Count	Dia.	Pitch	Rot.	Lau Part Number	Lau Pitch
Carrier	LA01LA042	3	18"	27°	CCW	60556201	27°
Carrier	LA01EB019	3	18"	27°	CCW	60556201	27°
Carrier	LA01EB01905	3	18"	27°	CCW	60556201	27°
Carrier	MADE IN MEXICO	3	18"	27°	CCW	60556201	27°
Carrier	1086406	3	18"	28°	CCW	60556201	27°
Carrier	LA680550	3	18"	28°	CCW	60556201	27°
Carrier	22311181	3	18"	28°	CCW	60556201	27°
Carrier	1080759	3	18"	30°	CW	60556301	30°
Carrier	LA01EB018	3	18"	32°	CCW	60556601	33°
Carrier	LA01EB01805	3	18"	32°	CCW	60556601	33°
Carrier	MADE IN MEXICO	3	18"	32°	CCW	60556601	33°
Carrier	LA680551	3	20"	24°	CW	60556701	27°
Carrier	1086516	3	20"	24°	CW	60556701	27°
Carrier	213456000	3	20"	25°	CW	60556701	27°
Carrier	LA680552	3	20"	28°	CW	60556701	27°
Carrier	LA680554	3	20"	28°	CW	60556701	27°
Carrier	1086446	3	20"	28°	CW	60556701	27°
Carrier	LA01LA019	3	20"	29°	CW	60556901	30°
Carrier	LA680553	3	20"	30°	CCW	60557001	30°
Carrier	2325472	3	20"	35°	CW	60557101	33°
Carrier	LA680556	3	22"	30°	CW	60557301	27°
Carrier	LA680522	3	22"	24°	CCW	60557401	27°
Carrier	LA680557	3	22"	30°	CCW	60557401	27°
Carrier	LA680527	3	22"	34°	CW	60557501	33°
Carrier	LA680558	3	24"	24°	CW	60557701	27°
Carrier	LA01LA024	3	24"	27°	CW	60557701	27°
Carrier	LA680559	3	24"	28°	CW	60557701	27°
Carrier	LA01LA044	3	24"	24°	CCW	60557801	27°
Carrier	LA680560	3	24"	28°	CCW	60557801	27°
Carrier	213266000	3	24"	28°	CCW	60557801	27°
Carrier	213455000	3	24"	32°	CW	60557901	33°
Carrier	22311241	3	24"	30°	CCW	60558001	33°
Carrier	2325315	3	24"	33°	CCW	60558001	33°
Carrier	215112000	3	12"	23°	CW	60716301	23°
Carrier	08221156	3	14"	26°	CW	60716701	27°
Carrier	LA680539	3	16"	24°	CW	60717101	23°

While Lau makes every effort to provide accurate and complete information, the recommended propeller replacement is the closest match to Lau stock products. It is up to the individual purchaser to double-check performance to guarantee the correct propeller application. Lau reserves the right to make changes to this catalog, at any time and without notice, to prices, specifications and models and is not responsible for typographical or image errors.

APPENDIX D



OEM Cross Reference

OEM Name	OEM Part Number	Blade Count	Dia.	Pitch	Rot.	Lau Part Number	Lau Pitch
Carrier	59310540	3	16"	25°	CCW	60717201	23°
Carrier	LA01EW050	2	14"	34°	CW	60743401	36°
Carrier	2325305	2	18"	26°	CCW	60772501	28°
Carrier	38HD580-931	2	18"	28°	CCW	60772501	28°
Carrier	LA01AB023	2	20"	28°	CCW	60772601	28°
Carrier	LA01AB022	2	20"	31°	CCW	60772601	28°
Carrier	LA01EW044	2	24"	24°	CCW	60778201	27°
Carrier	38HD580-932	2	24"	24°	CCW	60778201	27°
Carrier	LA01EW044	2	24"	24°	CCW	60778201	27°
Carrier	2325306	2	24"	27°	CCW	60778201	27°
Carrier	38-00510-00Z	5	17½"	25°	CCW	60560601	27°
Carrier	20-25-0854	5	18"	25°	CCW	60560601	27°
Carrier	LA680540	5	22"	34°	CW	60561501	33°
Carrier	521125	5	24"	26°	CCW	60561801	27°
Carrier	2325509	5	26"	30°	CW	60761301	27°
Carrier	LA01AA177	3	18"	26°	CW	60556101	27°
Carrier	1068920	3	18"	26°	CW	60556101	27°
Carrier	LA680549	3	18"	28°	CW	60556101	27°
Carrier	1085958	3	18"	28°	CW	60556101	27°
Carrier	LA01LB018	3	18"	25°	CCW	60556201	27°
Carrier	LA01EB019	3	18"	27°	CCW	60556201	27°
Carrier	LA01LA042	3	18"	27°	CCW	60556201	27°
Carrier	1086406	3	18"	28°	CCW	60556201	27°
Carrier	1080759	3	18"	30°	CW	60556301	30°
Carrier	LA01EB018	3	18"	32°	CCW	60556601	33°
Carrier	LA680551	3	20"	24°	CW	60556701	27°
Carrier	1086516	3	20"	24°	CW	60556701	27°
Carrier	LA680554	3	20"	28°	CW	60556701	27°
Carrier	1086446	3	20"	28°	CW	60556701	27°
Carrier	LA01LA019	3	20"	29°	CW	60556901	30°
Carrier	LA680553	3	20"	30°	CCW	60557001	30°
Carrier	2325472	3	20"	35°	CW	60557101	33°
Carrier	LA680556	3	22"	30°	CW	60557301	27°
Carrier	LA680522	3	22"	24°	CCW	60557401	27°
Carrier	LA680557	3	22"	30°	CCW	60557401	27°
Carrier	LA680527	3	22"	34°	CW	60557501	33°

While Lau makes every effort to provide accurate and complete information, the recommended propeller replacement is the closest match to Lau stock products. It is up to the individual purchaser to double-check performance to guarantee the correct propeller application. Lau reserves the right to make changes to this catalog, at any time and without notice, to prices, specifications and models and is not responsible for typographical or image errors.

OEM Name	OEM Part Number	Blade Count	Dia.	Pitch	Rot.	Lau Part Number	Lau Pitch
Carrier	LA01LA024	3	24"	27°	CW	60557701	27°
Carrier	LA680559	3	24"	28°	CW	60557701	27°
Carrier	LA01LA044	3	24"	24°	CCW	60557801	27°
Carrier	LA680560	3	24"	28°	CCW	60557801	27°
Carrier	LA680539	3	16"	24°	CW	60717101	23°
Carrier	LA01EW050	2	14"	34°	CW	60743401	36°
Carrier	2325305	2	18"	26°	CCW	60772501	28°
Carrier	LA01AB023	2	20"	28°	CCW	60772601	28°
Carrier	LA01AB022	2	20"	31°	CCW	60772601	28°
Carrier	LA01EW044	2	24"	24°	CCW	60778201	27°
Carrier	2325306	2	24"	27°	CCW	60778201	27°
Carrier	LA01EW044	2	24"	24°	CCW	60778201	27°
CAT	51-124-000	4	18"	33°	CW	60558501	33°
CCI Thermal Technologies	7494	4	16"	27°	CW	60719501	27°
CCI Thermal Technologies	4026	3	20"	24°	CW	60556701	27°
CCI Thermal Technologies	4023	3	12"	20°	CW	60716101	19°
CCI Thermal Technologies	4024	3	16"	16°	CW	60716901	19°
Chick Master Incubator	734B-01-4035	4	12"	28°	CW	60718301	27°
Chick Master Incubator	734B-06-4035	4	14"	30°	CW	60718901	27°
Chick Master Incubator	734B-06-4035	4	14"	30°	CW	60718901	27°
Chick Master Incubator	734B-13-4035	4	16"	26°	CW	60719501	27°
Chick Master Incubator	734B-15-4035	4	16"	34°	CW	60760501	33°
Chick Master Incubator	734B-19-4035	4	18"	22°	CW	60800201	23°
Chick Master Incubator	734B-20-4035	4	18"	26°	CW	60558101	27°
Chick Master Incubator	734B-51-4035	4	16"	16°	CW	60719101	19°
Chick Master Incubator	734B-56-4035	5	24"	30°	CW	60561701	27°
Chick Master Incubator	734B-02-4035	4	12"	34°	CW	60760101	33°
Chick Master Incubator	734B-55-4035	3	24"	29°	CW	60557701	27°
Chill Chamber	21S091	5	16"	27°	CW	60560101	27°
Chill Chamber	21S91	5	16"	27°	CW	60560101	27°
Chill Chamber	E315709	3	22"	36°	CCW	60557601	33°
Chill Chamber	21S92	3	16"	22°	CW	60717101	23°
Chill Chamber	0251098	5	16"	27°	CW	60560101	27°
Chill Chamber	97333512	3	20"	35°	CCW	60557201	33°
Chill Chamber	54366844	3	22"	35°	CCW	60557601	33°
Chill Chamber	81295222	3	16"	19°	CW	60716901	19°

While Lau makes every effort to provide accurate and complete information, the recommended propeller replacement is the closest match to Lau stock products. It is up to the individual purchaser to double-check performance to guarantee the correct propeller application. Lau reserves the right to make changes to this catalog, at any time and without notice, to prices, specifications and models and is not responsible for typographical or image errors.

APPENDIX D



OEM Cross Reference

OEM Name	OEM Part Number	Blade Count	Dia.	Pitch	Rot.	Lau Part Number	Lau Pitch
Chill Chamber	F0102800	4	20"	34°	CW	60559101	33°
Chill Chamber	F0102900	4	20"	34°	CW	60559101	33°
Chill Chamber	11252	4	21 ³ / ₄ "	27°	CW	60559301	27°
Chill Chamber	11259	4	21 ³ / ₄ "	27°	CCW	60559401	27°
Chill Chamber	11267	4	21 ³ / ₄ "	31°	CCW	60559601	33°
Chill Chamber	11269	4	21 ³ / ₄ "	29°	CW	60558301	30°
Chill Chamber	11285	4	24"	31°	CCW	60560001	33°
Chill Chamber	0048120	4	18"	32°	CW	60558501	33°
Chill Chamber	BF0102800	4	20"	34°	CW	60559101	33°
Chill Chamber	E205692	4	19 ³ / ₄ "	32°	CW	60559101	33°
Chill Chamber	54364641	4	16"	22°	CW	60719301	23°
Chill Chamber	11251	4	21 ¹³ / ₁₆ "	21°	CW	60804101	23°
Chill Chamber	3095C43G01	4	16"	22°	CW	60719301	23°
Chromalox	112-027567-001	4	16"	20°	CW	60719101	19°
Chromalox	112-045422-001	4	16"	19°	CW	60719101	19°
Chromalox	112-045422-002	4	16"	23°	CW	60719301	23°
Chromalox	112-130367-003	4	14"	24°	CCW	60718801	23°
Chromalox	112-130398-001	4	10"	18°	CW	60717301	19°
Chromalox	112-130398-002	4	10"	22°	CW	60717501	23°
Chromalox	112-044489-003	3	16"	24°	CW	60717101	23°
Clean Burn	31013	4	24"	20°	CW	60804301	23°
Clean Burn	31107	4	24"	25°	CW	60804301	23°
CNH Global	130219	3	12"	20°	CCW	60716201	19°
CNH Global	1275810C1	2	18"	26°	CCW	60772501	28°
CNH Global	D93696	2	18"	26°	CCW	60772501	28°
CNH Global	130219	3	12"	20°	CCW	60716201	19°
CNH Global	A164663	2	22"	25°	CCW	60814201	27°
Coilmaster Corp.	65000	4	18"	34°	CW	60558501	33°
Coilmaster Corp.	65100	4	22"	28°	CW	60559301	27°
Coilmaster Corp.	65200	4	26"	29°	CW	60760901	27°
Coldflow	12-235-67-3	4	16"	34°	CCW	60760601	33°
Coldflow	12-235-67-2	3	14"	20°	CCW	60716501	23°
Condor Products	018000074	5	22"	33°	CW	60561501	33°
Condor Products	018000075	5	24"	33°	CW	60561901	33°
Condor Products	021018000075	5	24"	33°	CW	60561901	33°
Condor Products	018000067	5	26"	27°	CW	60761301	27°

While Lau makes every effort to provide accurate and complete information, the recommended propeller replacement is the closest match to Lau stock products. It is up to the individual purchaser to double-check performance to guarantee the correct propeller application. Lau reserves the right to make changes to this catalog, at any time and without notice, to prices, specifications and models and is not responsible for typographical or image errors.

OEM Name	OEM Part Number	Blade Count	Dia.	Pitch	Rot.	Lau Part Number	Lau Pitch
Condor Products	18000074	5	22"	33°	CW	60561501	33°
Condor Products	18000067	5	26"	27°	CW	60761301	27°
Continental Chillers	ACFB42626	4	26"	26°	CW	60760901	27°
Continental Chillers	FBCC-52625	5	26"	25°	CCW	60761401	27°
Cooltec Refrigeration	4205	5	20"	33°	CW	60561101	33°
Cooltec Refrigeration	4210	5	24"	27°	CW	60561701	27°
Copeland or Emerson	083-0115-00	5	24"	29°	CW	60561701	27°
Copeland or Emerson	083-0114-00	5	24"	34°	CW	60561901	33°
Copeland or Emerson	083-0057-01	3	24"	36°	CW	60557901	33°
Copeland or Emerson	083-0103-01	3	14"	22°	CW	60716501	23°
Copeland or Emerson	083-0103-00	3	14"	22°	CW	60716501	23°
Copeland or Emerson	083-0100-00	3	16"	17°	CW	60716901	19°
Daikin - Modine	BPF01168-2	3	24"	26°	CW	60557701	27°
Daikin - Modine	BPF01168-4	3	24"	30°	CW	60557901	33°
Danfoss	7002002	4	22"	32°	CW	60559501	33°
Danfoss	1910139100	4	12"	33°	CW	60760101	33°
Danfoss	7002000	2	14"	33°	CW	60743401	36°
Dectron Inc	RFN0040	4	20"	34°	CW	60559101	33°
Dectron Inc	RFN-0041	4	20"	34°	CW	60559101	33°
Del-Air Systems LTD	000787	3	20"	30°	CW	60556901	30°
Del-Air Systems LTD	000784	3	24"	32°	CW	60557901	33°
Desa Heating	100-044	4	24"	22°	CW	60804301	23°
Desa Heating	100-201	4	24"	24°	CW	60804301	23°
Desa Heating	400-003	3	20"	30°	CW	60556901	30°
Dielectric	0040505000	4	18"	23°	CW	60800201	23°
Dryomatic Corp.	61172701	4	20"	27°	CW	60558701	27°
Dunham Bush Inc.	520-046	4	12"	25°	CCW	60718201	23°
Dunham Bush Inc.	E230282	4	26"	22°	CW	60760701	24°
Dunham Bush Inc.	2004140001	4	14"	30°	CW	60718901	27°
Dunham Bush Inc.	2004180003	4	18"	30°	CW	60558301	30°
Dunham Bush Inc.	2004200005	4	20"	30°	CW	60558901	30°
Dynaflux Corp.	R4000	5	16"	35°	CW	60560301	33°
Dynapower Corp.	46-049	5	24"	27°	CCW	60561801	27°
Econo Heat	10079	4	18"	36°	CW	60558501	33°
Economy Refri & Vent Supply	1827.50CWI	3	18"	27°	CW	60556101	27°
Economy Refri & Vent Supply	1427.38CWI	3	14"	27°	CW	60716701	27°

While Lau makes every effort to provide accurate and complete information, the recommended propeller replacement is the closest match to Lau stock products. It is up to the individual purchaser to double-check performance to guarantee the correct propeller application. Lau reserves the right to make changes to this catalog, at any time and without notice, to prices, specifications and models and is not responsible for typographical or image errors.

APPENDIX D



OEM Cross Reference

OEM Name	OEM Part Number	Blade Count	Dia.	Pitch	Rot.	Lau Part Number	Lau Pitch
Economy Refri & Vent Supply	1427.50CWI	3	14"	27°	CW	60716701	27°
Economy Refri & Vent Supply	1623.38CWI	3	16"	23°	CW	60717101	23°
Economy Refri & Vent Supply	1020.31CWI	4	10"	20°	CW	60717301	19°
Economy Refri & Vent Supply	1020.31CWD	4	10"	20°	CW	60717301	19°
Economy Refri & Vent Supply	1827.50CWD	3	18"	27°	CW	60556101	27°
Economy Refri & Vent Supply	1427.38CWD	3	14"	27°	CW	60716701	27°
Economy Refri & Vent Supply	1623.38CWD	3	16"	23°	CW	60717101	23°
Edwards Eng. Corp.	CV18010	5	18"	27°	CW	60560501	27°
Emerson or Copeland	083-0115-00	5	24"	29°	CW	60561701	27°
Emerson or Copeland	083-0114-00	5	24"	34°	CW	60561901	33°
Emerson or Copeland	083-0057-01	3	24"	36°	CW	60557901	33°
Emerson or Copeland	083-0103-01	3	14"	22°	CW	60716501	23°
Emerson or Copeland	083-0103-00	3	14"	22°	CW	60716501	23°
Emerson or Copeland	083-0100-00	3	16"	17°	CW	60716901	19°
Emerson or Copeland	112-044489-003	3	16"	24°	CW	60717101	23°
Emerson or Copeland	112-302303-019	2	20"	28°	CCW	60772601	28°
Emerson or Copeland	083-0033-00	4	14"	30°	CW	60718901	27°
Emerson or Copeland	083-0072-00	4	16"	31°	CW	60760501	33°
Emerson or Copeland	083-0117-00	4	10"	35°	CW	60759901	33°
Emerson or Copeland	083-0123-00	4	14"	35°	CW	60760301	33°
Emerson or Copeland	112-027567-001	4	16"	20°	CW	60719101	19°
Emerson or Copeland	112-045422-001	4	16"	19°	CW	60719101	19°
Emerson or Copeland	112-045422-002	4	16"	23°	CW	60719301	23°
Emerson or Copeland	112-130367-003	4	14"	24°	CCW	60718801	23°
Emerson or Copeland	112-130398-001	4	10"	18°	CW	60717301	19°
Emerson or Copeland	112-130398-002	4	10"	22°	CW	60717501	23°
EMI Enviromaster	131000007	3	20"	30°	CCW	60557001	30°
Empire Comfort Systems	642012	4	14"	34°	CW	60760301	33°
Engineered Air	F02CF10A1025.31CWD	4	10"	25°	CW	60717701	27°
Engineered Air	F02CY12A1225.38CWD	4	12"	25°	CW	60718101	23°
Engineered Air	F07CH081634.50CWD	4	16"	34°	CW	60760501	33°
Enpro International	02614271	5	20"	33°	CW	60561101	33°
Enpro International	02631361000	3	24"	25°	CW	60557701	27°
Enpro International	2620361001	3	24"	26°	CW	60557701	27°
Enpro International	2612696000	4	24"	20°	CW	60804301	23°
Enpro International	2614271000	5	20"	33°	CW	60561101	33°

While Lau makes every effort to provide accurate and complete information, the recommended propeller replacement is the closest match to Lau stock products. It is up to the individual purchaser to double-check performance to guarantee the correct propeller application. Lau reserves the right to make changes to this catalog, at any time and without notice, to prices, specifications and models and is not responsible for typographical or image errors.

OEM Name	OEM Part Number	Blade Count	Dia.	Pitch	Rot.	Lau Part Number	Lau Pitch
Enpro International	2634757000	3	24"	29°	CW	60557701	27°
Environmental Systems	1559AS-250	2	20"	30°	CCW	60772601	28°
ESAB Group	8672058	4	12"	30°	CW	60718301	27°
Eubank Manufacturing & Eng.	251505	3	18"	27°	CCW	60556201	27°
Eubank Manufacturing & Eng.	251450	3	22"	24°	CCW	60557401	27°
Eubank Manufacturing & Eng.	259114	3	22"	25°	CW	60557301	27°
Eubank Manufacturing & Eng.	251530	4	22"	29°	CW	60559301	27°
Evapco	14-1059	3	24"	24°	CCW	60557801	27°
Evapco	014-01059P	3	24"	24°	CW	60557701	27°
Evcon Industries	026-35492-000	4	24"	30°	CW	60559701	27°
Evcon Industries	026-35536-000	4	20"	34°	CW	60559101	33°
Evcon Industries	7836-324	4	18"	35°	CCW	60558601	33°
Evcon Industries	026-34754-000	3	18"	24°	CW	60556101	27°
Evcon Industries	026-34092-000	3	18"	31°	CW	60556301	30°
Evcon Industries	026-37301-000	3	20"	26°	CW	60556701	27°
Evcon Industries	026-34593-000	3	22"	30°	CW	60557301	27°
Evcon Industries	026-34094-000	3	22"	36°	CW	60557501	33°
Evcon Industries	026-31361-000	3	24"	25°	CW	60557701	27°
Evcon Industries	026-35437-000	3	24"	26°	CW	60557701	27°
Fedders	0516N-0021A	4	24"	36°	CW	60559901	33°
Fedders	0516P-0034	4	26"	30°	CW	60760901	27°
Fedders	259114	3	22"	25°	CW	60557301	27°
Fedders	5151N-0213A	3	22"	25°	CCW	60557401	27°
First Company	FB1630	5	16"	30°	CCW	60560201	27°
Flair Corp.	7DE41VQ	4	24"	26°	CCW	60559801	27°
Flair Corp.	7DE41AGQ	3	24"	28°	CCW	60557801	27°
Flair Corp.	7DE41VG	3	14"	25°	CW	60716501	23°
Flair Corp.	7DE41ACL	3	14"	26°	CW	60716701	27°
Flair Corp.	7DE41ADY	4	16"	22°	CCW	60719401	23°
Flair Corp.	7DE41VP	4	20"	27°	CCW	60558801	27°
Flair Corp.	7DE41AEC	3	14"	22°	CW	60716501	23°
Flo-Aire	34180000	4	18"	36°	CCW	60558601	33°
Flo-Aire	34DDA	3	20"	30°	CCW	60557001	30°
Flo-Aire	3424RPRP	3	24"	24°	CW	60557701	27°
Focus Temp International	30-1106	4	20"	30°	CCW	60559001	30°
Focus Temp International	30-1107	4	22"	26°	CCW	60559401	27°

While Lau makes every effort to provide accurate and complete information, the recommended propeller replacement is the closest match to Lau stock products. It is up to the individual purchaser to double-check performance to guarantee the correct propeller application. Lau reserves the right to make changes to this catalog, at any time and without notice, to prices, specifications and models and is not responsible for typographical or image errors.

APPENDIX D



OEM Cross Reference

OEM Name	OEM Part Number	Blade Count	Dia.	Pitch	Rot.	Lau Part Number	Lau Pitch
Focus Temp International	30-1110	4	14"	26°	CW	60718901	27°
Freeze Co Systems	FCACO1-2	5	20"	30°	CW	60560901	27°
Freeze Co Systems	FCAC02-4	5	24"	28°	CW	60561701	27°
Fresh Air Solutions	41202.06	3	24"	30°	CW	60557901	33°
Frigid Coil	013187	5	20"	27°	CW	60560901	27°
Frigid Coil	013158	3	24"	30°	CW	60557901	33°
Future Products	07335319	3	16"	26°	CCW	60717201	23°
GAL-ON	F07H08	4	20"	28°	CW	60558701	27°
GAL-ON	F10H08A	4	24"	22°	CCW	60804401	23°
Gardner-Denver	03661626-0032	5	20"	28°	CCW	60561001	27°
Gast Mfg	AD721	4	10"	34°	CW	60759901	33°
General Electric	112A7299FHP21	4	12"	24°	CW	60718101	23°
General Electric	W3112FYP1	5	24"	25°	CW	60561701	27°
General Electric	W3112HTP1	5	26"	31°	CW	60761501	33°
General Electric	151X1220PG01PC04	5	16"	35°	CW	60560301	33°
General Electric	151X1220PG01PC03	5	16"	27°	CW	60560101	27°
Gess	112A7299FHP21	4	12"	24°	CW	60718101	23°
Gess	W3112FYP1	5	24"	25°	CW	60561701	27°
Gess	W3112HTP1	5	26"	31°	CW	60761501	33°
Goettl Air Conditioning	601063	4	24"	32°	CCW	60560001	33°
Goettl Air Conditioning	601054	2	18"	35°	CCW	60652101	33°
Goodman	B1086750	3	22"	24°	CCW	60557401	27°
Goodman	B1086748	3	22"	30°	CCW	60557401	27°
Goodman	10625723	3	22"	33°	CW	60557501	33°
Goodman	B1086762	3	24"	30°	CW	60557901	33°
Goodman	10625716	3	18"	26°	CW	60556101	27°
Goodman	10625703	3	18"	28°	CW	60556101	27°
Goodman	10625726	3	18"	28°	CCW	60556201	27°
Goodman	10625728	3	18"	28°	CCW	60556201	27°
Goodman	10625729	3	18"	29°	CCW	60556401	30°
Goodman	B10867-56	3	18"	29°	CCW	60556401	30°
Goodman	10625721	3	18"	33°	CW	60556501	33°
Goodman	B10867-57	3	18"	36°	CCW	60556601	33°
Goodman	B10867-49	3	20"	30°	CCW	60557001	30°
Goodman	B10867-47	3	20"	36°	CCW	60557201	33°
Goodman	10625704	3	22"	28°	CW	60557301	27°

While Lau makes every effort to provide accurate and complete information, the recommended propeller replacement is the closest match to Lau stock products. It is up to the individual purchaser to double-check performance to guarantee the correct propeller application. Lau reserves the right to make changes to this catalog, at any time and without notice, to prices, specifications and models and is not responsible for typographical or image errors.

OEM Name	OEM Part Number	Blade Count	Dia.	Pitch	Rot.	Lau Part Number	Lau Pitch
Goodman	10625722	3	22"	29°	CW	60557301	27°
Goodman	B10867-50	3	22"	24°	CCW	60557401	27°
Goodman	B10867-48	3	22"	30°	CCW	60557401	27°
Goodman	10625723	3	22"	33°	CW	60557501	33°
Goodman	10625706	3	22"	33°	CW	60557501	33°
Goodman	B10867-62	3	24"	30°	CW	60557901	33°
Goodman	B10867-58	3	16"	24°	CCW	60717201	23°
Goodman	B1086749	3	20"	30°	CCW	60557001	30°
Goodman	B1086760	3	24"	27°	CW	60557701	27°
Goodman	B10867-61	4	22"	27°	CW	60559301	27°
Goodman	B10867-69	4	26"	22°	CW	60760701	24°
Goodman	B10867-53	2	18"	33°	CCW	60652101	33°
Goodman	10625727	2	18"	27°	CCW	60772501	28°
GSI Group	MIS-6689	3	18"	29°	CW	60556301	30°
Hackney	15280042201	4	10"	18°	CW	60717301	19°
Hallowell International	FBL-0103	3	22"	28°	CW	60557301	27°
Hastings	71-09-0120-19	4	16"	26°	CW	60719501	27°
Hastings	71-09-0250-13	3	20"	28°	CW	60556701	27°
Hatchery Planning	JW8011	4	16"	32°	CW	60760501	33°
Hatchery Planning	JW8012	4	16"	26°	CW	60719501	27°
Hatchery Planning	JW8013	5	16"	30°	CW	60560101	27°
Haul All Equipment	561-6153	5	18"	32°	CCW	60561201	33°
Hayden Industrial Products	21300	5	16"	26°	CW	60560101	27°
Hayden Industrial Products	007756	5	24"	24°	CW	60561701	27°
Heat Wagons	40SM08	4	14"	30°	CW	60718901	27°
Heat Wagons	SFP-2420	4	14"	30°	CW	60718901	27°
Heat Wagons	HP1161	5	18"	36°	CCW	60561201	33°
Heatcraft	2291624	3	16"	25°	CW	60717101	23°
Heatcraft	2291836	5	18"	34°	CW	60560701	33°
Heatcraft	2292422	4	24"	24°	CW	60804301	23°
Heatcraft	2292423	4	24"	24°	CW	60804301	23°
Heatcraft	2292625	4	26"	28°	CW	60760901	27°
Heatcraft	2292630	4	26"	32°	CW	60761101	33°
Heatcraft	7173254	5	26"	26°	CW	60761301	27°
Heatcraft	22900201	4	24"	27°	CW	60559701	27°
Heatcraft	22902001	4	16"	31°	CW	60760501	33°

While Lau makes every effort to provide accurate and complete information, the recommended propeller replacement is the closest match to Lau stock products. It is up to the individual purchaser to double-check performance to guarantee the correct propeller application. Lau reserves the right to make changes to this catalog, at any time and without notice, to prices, specifications and models and is not responsible for typographical or image errors.

APPENDIX D



OEM Cross Reference

OEM Name	OEM Part Number	Blade Count	Dia.	Pitch	Rot.	Lau Part Number	Lau Pitch
Heatcraft	22902101	4	14"	35°	CW	60760301	33°
Heatcraft	22999901	5	17 ¹³ / ₁₆ "	35°	CW	60560701	33°
Heatcraft	29218600	4	24"	28°	CW	60559701	27°
Heatcraft	22900201	4	24"	27°	CW	60559701	27°
Heatcraft	2291836	5	18"	34°	CW	60560701	33°
Heatcraft	229-2422	4	24"	24°	CW	60804301	23°
Heatcraft	2292423	4	24"	24°	CW	60804301	23°
Heatcraft	2292625	4	26"	28°	CW	60760901	27°
Heatcraft	2292629	4	26"	29°	CW	60760901	27°
Heatcraft	2292630	4	26"	32°	CW	60761101	33°
Heatcraft	5101E	4	16"	34°	CW	60760501	33°
Heatcraft	5102E	4	18"	33°	CCW	60558601	33°
Heatcraft	5107B	3	14"	23°	CCW	60716601	23°
Heatcraft	5107C	2	20"	25°	CCW	60772601	28°
Heatcraft	5146C	3	14"	29°	CW	60716701	27°
Heatcraft	5148C	3	14"	29°	CCW	60716801	27°
Heatcraft	7173254	5	26"	26°	CW	60761301	27°
Hill Phoenix	10947	4	16"	28°	CCW	60719601	27°
Hill Phoenix	Q60111010	5	18"	33°	CW	60560701	33°
Hobart	406991	4	14"	25°	CCW	60718801	23°
Hobart	406991	4	14"	25°	CCW	60718801	23°
Hobart	8RT-609	4	12"	22°	CCW	60718201	23°
Hoshizaki	4A2260-01	5	16"	32°	CW	60560301	33°
Hoshizaki	4A1493-01	3	14"	29°	CW	60716701	27°
Hussman or Blanchard-Ness	F0102900	4	20"	34°	CW	60559101	33°
Hussmann	21S091	5	16"	27°	CW	60560101	27°
Hussmann	21S91	5	16"	27°	CW	60560101	27°
Hussmann	E315709	3	22"	36°	CCW	60557601	33°
Hussmann	21S92	3	16"	22°	CW	60717101	23°
Hussmann	0251098	5	16"	27°	CW	60560101	27°
Hussmann	97333512	3	20"	35°	CCW	60557201	33°
Hussmann	54366844	3	22"	35°	CCW	60557601	33°
Hussmann	81295222	3	16"	19°	CW	60716901	19°
Hussmann	F0102800	4	20"	34°	CW	60559101	33°
Hussmann	F0102900	4	20"	34°	CW	60559101	33°
Hussmann	11252	4	21 ³ / ₄ "	27°	CW	60559301	27°

While Lau makes every effort to provide accurate and complete information, the recommended propeller replacement is the closest match to Lau stock products. It is up to the individual purchaser to double-check performance to guarantee the correct propeller application. Lau reserves the right to make changes to this catalog, at any time and without notice, to prices, specifications and models and is not responsible for typographical or image errors.

OEM Name	OEM Part Number	Blade Count	Dia.	Pitch	Rot.	Lau Part Number	Lau Pitch
Hussmann	11259	4	21 ³ / ₄ "	27°	CCW	60559401	27°
Hussmann	11267	4	21 ³ / ₄ "	31°	CCW	60559601	33°
Hussmann	11269	4	17 ³ / ₄ "	29°	CW	60558301	30°
Hussmann	11285	4	24"	31°	CCW	60560001	33°
Hussmann	0048120	4	18"	32°	CW	60558501	33°
Hussmann	BF0102800	4	20"	34°	CW	60559101	33°
Hussmann	E205692	4	19 ³ / ₄ "	32°	CW	60559101	33°
Hussmann	54364641	4	16"	22°	CW	60719301	23°
Hussmann	11251	4	21 ¹³ / ₁₆ "	21°	CW	60804101	23°
Hussmann	3095C43G01	4	16"	22°	CW	60719301	23°
Hydrotemp	703	4	22"	27°	CW	60559301	27°
Hydrotemp	713	5	22"	30°	CCW	60561401	27°
IBT Inc.	45070170L	3	12"	18°	CCW	60716201	19°
IBT Inc.	45070170L	3	12"	18°	CCW	60716201	19°
ICE Manufacturing	50103	5	16"	27°	CCW	60560201	27°
ICP (International Comfort Products)	1080763	4	20"	36°	CW	60559101	33°
ICP (International Comfort Products)	2325270	4	20"	35°	CCW	60559201	33°
ICP (International Comfort Products)	2325501	4	22"	31°	CCW	60559601	33°
ICP (International Comfort Products)	2325503	4	24"	36°	CW	60559901	33°
ICP (International Comfort Products)	2325508	5	22"	35°	CW	60561501	33°
ICP (International Comfort Products)	521125	5	24"	26°	CCW	60561801	27°
ICP (International Comfort Products)	2325509	5	26"	30°	CW	60761301	27°
ICP (International Comfort Products)	1068920	3	18"	26°	CW	60556101	27°
ICP (International Comfort Products)	1085958	3	18"	28°	CW	60556101	27°
ICP (International Comfort Products)	1086406	3	18"	28°	CCW	60556201	27°
ICP (International Comfort Products)	1080753	3	18"	36°	CCW	60556601	33°
ICP (International Comfort Products)	1086516	3	20"	24°	CW	60556701	27°
ICP (International Comfort Products)	1086446	3	20"	28°	CW	60556701	27°
ICP (International Comfort Products)	2325472	3	20"	35°	CW	60557101	33°
ICP (International Comfort Products)	2325315	3	24"	33°	CCW	60558001	33°
ICP (International Comfort Products)	2325305	2	18"	26°	CCW	60772501	28°
ICP (International Comfort Products)	2325306	2	24"	27°	CCW	60778201	27°
IMC Magnetics	68-208-1	4	12"	19°	CW	60717901	19°
IMI	638008618	4	10"	32°	CW	60759901	33°
IMI	630900246	3	18"	31°	CW	60556301	30°
IMI	630900245	3	14"	26°	CW	60716701	27°

While Lau makes every effort to provide accurate and complete information, the recommended propeller replacement is the closest match to Lau stock products. It is up to the individual purchaser to double-check performance to guarantee the correct propeller application. Lau reserves the right to make changes to this catalog, at any time and without notice, to prices, specifications and models and is not responsible for typographical or image errors.

APPENDIX D



OEM Cross Reference

OEM Name	OEM Part Number	Blade Count	Dia.	Pitch	Rot.	Lau Part Number	Lau Pitch
IMI	638008618	4	10"	32°	CW	60759901	33°
Ingersoll-Rand	21S091	5	16"	27°	CW	60560101	27°
Ingersoll-Rand	21S91	5	16"	27°	CW	60560101	27°
Ingersoll-Rand	E315709	3	22"	36°	CCW	60557601	33°
Ingersoll-Rand	21S92	3	16"	22°	CW	60717101	23°
Ingersoll-Rand	0251098	5	16"	27°	CW	60560101	27°
Ingersoll-Rand	97333512	3	20"	35°	CCW	60557201	33°
Ingersoll-Rand	54366844	3	22"	35°	CCW	60557601	33°
Ingersoll-Rand	81295222	3	16"	19°	CW	60716901	19°
Ingersoll-Rand	F0102800	4	20"	34°	CW	60559101	33°
Ingersoll-Rand	F0102900	4	20"	34°	CW	60559101	33°
Ingersoll-Rand	11252	4	21 ³ / ₄ "	27°	CW	60559301	27°
Ingersoll-Rand	11259	4	21 ³ / ₄ "	27°	CCW	60559401	27°
Ingersoll-Rand	11267	4	21 ³ / ₄ "	31°	CCW	60559601	33°
Ingersoll-Rand	11269	4	17 ³ / ₄ "	29°	CW	60558301	30°
Ingersoll-Rand	11285	4	24"	31°	CCW	60560001	33°
Ingersoll-Rand	0048120	4	18"	32°	CW	60558501	33°
Ingersoll-Rand	BF0102800	4	20"	34°	CW	60559101	33°
Ingersoll-Rand	54364641	4	16"	22°	CW	60719301	23°
Ingersoll-Rand	11251	4	21 ¹³ / ₁₆ "	21°	CW	60804101	23°
Ingersoll-Rand	3095C43G01	4	16"	22°	CW	60719301	23°
ITW Food Equipment	406991	4	14"	25°	CCW	60718801	23°
J & D Manufacturing	VRB20A	3	20"	24°	CW	60556701	27°
J & D Manufacturing	VRB16AS	3	16"	17°	CW	60716901	19°
J & D Manufacturing	VRBT20A	3	20"	24°	CW	60556701	27°
J & D Manufacturing	VRB12ES	3	12"	23°	CW	60716301	23°
J & D Manufacturing	A164663	2	22"	25°	CCW	60814201	27°
Jamesway Incubator	PB2824	4	16"	26°	CCW	60719601	27°
Jamesway Incubator	PB2825	4	16"	32°	CCW	60760601	33°
Jamesway Incubator	PB4350	4	16"	26°	CW	60719501	27°
Jamesway Incubator	PB4351	4	16"	32°	CW	60760501	33°
Jamesway Incubator	PB5142	4	16"	32°	CW	60760501	33°
Jamesway Incubator	PB5143	4	16"	32°	CCW	60760601	33°
Jamesway Incubator	PB4133	5	16"	30°	CW	60560101	27°
Jamesway Incubator	PB5145	5	16"	35°	CCW	60560401	33°
Jamesway Incubator	PB4297	5	16"	30°	CCW	60560201	27°

While Lau makes every effort to provide accurate and complete information, the recommended propeller replacement is the closest match to Lau stock products. It is up to the individual purchaser to double-check performance to guarantee the correct propeller application. Lau reserves the right to make changes to this catalog, at any time and without notice, to prices, specifications and models and is not responsible for typographical or image errors.

OEM Name	OEM Part Number	Blade Count	Dia.	Pitch	Rot.	Lau Part Number	Lau Pitch
Jamesway Incubator	PB5144	5	16"	35°	CW	60560301	33°
Jenny Products	LF-BACW1225500	3	12"	25°	CW	60716301	23°
Jenny Products	LF-BACW1626500	3	16"	26°	CW	60717101	23°
Johnson Marcraft	AS1039-005	4	16"	28°	CW	60719501	27°
Keco Industries	605517	4	16"	35°	CCW	60760601	33°
Keeprite	1042786	4	16"	34°	CCW	60760601	33°
Keeprite	107004	5	26"	33°	CW	60761501	33°
Keeprite	1082709	4	20"	24°	CW	60800401	23°
Kidron	5280042201	4	10"	18°	CW	60717301	19°
Kinco	7DE41AGQ	3	24"	28°	CCW	60557801	27°
Kinco	490019002	3	12"	22°	CW	60716301	23°
Kinco	490011001	3	12"	25°	CW	60716301	23°
Kinco	7DE41AEC	3	14"	22°	CW	60716501	23°
Kinco	7DE41VG	3	14"	25°	CW	60716501	23°
Kinco	7DE41ACL	3	14"	26°	CW	60716701	27°
Kinco	1210-0098-000	3	16"	25°	CCW	60717201	23°
King Co	490020000	4	14"	30°	CW	60718901	27°
King Co	490022000	4	16"	24°	CW	60719301	23°
King Co	7DE41ADY	4	16"	22°	CCW	60719401	23°
King Co	7DE41VP	4	20"	27°	CCW	60558801	27°
King Co	7DE41VQ	4	24"	26°	CCW	60559801	27°
Klinge Corp.	K26-24606-00	2	20"	26°	CCW	60772601	28°
K-O Concepts	61133201	4	12"	23°	CCW	60718201	23°
Kold Pack	KP530	3	14"	29°	CW	60716701	27°
Kold Pack	KP531	3	14"	29°	CCW	60716801	27°
Kolpack Industries	3641	3	16"	26°	CCW	60717201	23°
Kool Jet	36-36-2143-01	4	24"	23°	CW	60804301	23°
Koolant Coolers	4500031	4	16"	30°	CW	60719501	27°
Koolant Coolers	4500032	4	18"	28°	CW	60558101	27°
Koolant Coolers	4500033	4	16"	30°	CCW	60719601	27°
Koolant Coolers	4500035	4	18"	28°	CW	60558101	27°
Koolant Coolers	4500036	4	16"	30°	CW	60719501	27°
Koolant Coolers	4500028	5	24"	33°	CCW	60562001	33°
Kooltronic	20895	5	14"	27°	CW	60721301	27°
Kopec Enterprises	KEI-0120	3	24"	28°	CW	60557701	27°
Koxka	21S091	5	16"	27°	CW	60560101	27°

While Lau makes every effort to provide accurate and complete information, the recommended propeller replacement is the closest match to Lau stock products. It is up to the individual purchaser to double-check performance to guarantee the correct propeller application. Lau reserves the right to make changes to this catalog, at any time and without notice, to prices, specifications and models and is not responsible for typographical or image errors.

APPENDIX D



OEM Cross Reference

OEM Name	OEM Part Number	Blade Count	Dia.	Pitch	Rot.	Lau Part Number	Lau Pitch
Koxka	21S91	5	16"	27°	CW	60560101	27°
Koxka	E315709	3	22"	36°	CCW	60557601	33°
Koxka	21S92	3	16"	22°	CW	60717101	23°
Koxka	0251098	5	16"	27°	CW	60560101	27°
Koxka	97333512	3	20"	35°	CCW	60557201	33°
Koxka	54366844	3	22"	35°	CCW	60557601	33°
Koxka	81295222	3	16"	19°	CW	60716901	19°
Koxka	F0102800	4	20"	34°	CW	60559101	33°
Koxka	F0102900	4	20"	34°	CW	60559101	33°
Koxka	11252	4	21 ³ / ₄ "	27°	CW	60559301	27°
Koxka	11259	4	21 ³ / ₄ "	27°	CCW	60559401	27°
Koxka	11267	4	21 ³ / ₄ "	31°	CCW	60559601	33°
Koxka	11269	4	17 ³ / ₄ "	29°	CW	60558301	30°
Koxka	11285	4	24"	31°	CCW	60560001	33°
Koxka	0048120	4	18"	32°	CW	60558501	33°
Koxka	BF0102800	4	20"	34°	CW	60559101	33°
Koxka	E205692	4	19 ³ / ₄ "	32°	CW	60559101	33°
Koxka	54364641	4	16"	22°	CW	60719301	23°
Koxka	11251	4	21 ¹³ / ₁₆ "	21°	CW	60804101	23°
Koxka	3095C43G01	4	16"	22°	CW	60719301	23°
Krack	21S091	5	16"	27°	CW	60560101	27°
Krack	21S91	5	16"	27°	CW	60560101	27°
Krack	E315709	3	22"	36°	CCW	60557601	33°
Krack	21S92	3	16"	22°	CW	60717101	23°
Krack	0251098	5	16"	27°	CW	60560101	27°
Krack	97333512	3	20"	35°	CCW	60557201	33°
Krack	54366844	3	22"	35°	CCW	60557601	33°
Krack	81295222	3	16"	19°	CW	60716901	19°
Krack	F0102800	4	20"	34°	CW	60559101	33°
Krack	F0102900	4	20"	34°	CW	60559101	33°
Krack	11252	4	21 ³ / ₄ "	27°	CW	60559301	27°
Krack	11259	4	21 ³ / ₄ "	27°	CCW	60559401	27°
Krack	11267	4	21 ³ / ₄ "	31°	CCW	60559601	33°
Krack	11269	4	17 ³ / ₄ "	29°	CW	60558301	30°
Krack	11285	4	24"	31°	CCW	60560001	33°
Krack	0048120	4	18"	32°	CW	60558501	33°

While Lau makes every effort to provide accurate and complete information, the recommended propeller replacement is the closest match to Lau stock products. It is up to the individual purchaser to double-check performance to guarantee the correct propeller application. Lau reserves the right to make changes to this catalog, at any time and without notice, to prices, specifications and models and is not responsible for typographical or image errors.

OEM Name	OEM Part Number	Blade Count	Dia.	Pitch	Rot.	Lau Part Number	Lau Pitch
Krack	BF0102800	4	20"	34°	CW	60559101	33°
Krack	E205692	4	19 ³ / ₄ "	32°	CW	60559101	33°
Krack	54364641	4	16"	22°	CW	60719301	23°
Krack	11251	4	21 ¹³ / ₁₆ "	21°	CW	60804101	23°
Krack	3095C43G01	4	16"	22°	CW	60719301	23°
Krenz & Co	BLA-A9847	4	12"	28°	CCW	60718401	27°
Krenz & Co	BLA-A9081-1	5	24"	25°	CW	60561701	27°
Kysor Warren	09B10053	3	16"	26°	CCW	60717201	23°
Leader Fan Industries	1B404	4	20"	30°	CW	60558901	30°
Leader Fan Industries	1B452	4	24"	20°	CW	60804301	23°
Leader Fan Industries	1B455	3	24"	24°	CW	60557701	27°
Lennox	2292423	4	24"	24°	CW	60804301	23°
Lennox	2292625	4	26"	28°	CW	60760901	27°
Lennox	2292629	4	26"	29°	CW	60760901	27°
Lennox	2292630	4	26"	32°	CW	60761101	33°
Lennox	22900201	4	24"	27°	CW	60559701	27°
Lennox	029218600	4	24"	28°	CCW	60559801	27°
Lennox	11G3901	4	24"	34°	CW	60559901	33°
Lennox	12F2001	4	24"	25°	CW	60804301	23°
Lennox	14B9901	4	24"	32°	CCW	60560001	33°
Lennox	15F6701	4	24"	22°	CCW	60804401	23°
Lennox	16C0101	4	24"	27°	CW	60559701	27°
Lennox	229-2422	4	24"	24°	CW	60804301	23°
Lennox	23G8301	4	24"	25°	CCW	60804401	23°
Lennox	29F8001	4	24"	22°	CW	60804301	23°
Lennox	37373B001	4	20"	25°	CW	60800401	23°
Lennox	43G3801	4	22"	28°	CW	60559301	27°
Lennox	5101E	4	16"	34°	CW	60760501	33°
Lennox	5102E	4	18"	33°	CCW	60558601	33°
Lennox	54G3001	4	24"	24°	CW	60804301	23°
Lennox	67C0501	4	22"	28°	CW	60559301	27°
Lennox	68J4301	4	22"	24°	CCW	60804201	23°
Lennox	89F4301	4	18"	26°	CCW	60558201	27°
Lennox	99C6201	4	17 ³ / ₄ "	20°	CW	60800201	23°
Lennox	P-8-10387	4	19 ³ / ₄ "	22°	CW	60800401	23°
Lennox	P-8-10388	4	19 ³ / ₄ "	34°	CW	60559101	33°

While Lau makes every effort to provide accurate and complete information, the recommended propeller replacement is the closest match to Lau stock products. It is up to the individual purchaser to double-check performance to guarantee the correct propeller application. Lau reserves the right to make changes to this catalog, at any time and without notice, to prices, specifications and models and is not responsible for typographical or image errors.

APPENDIX D



OEM Cross Reference

OEM Name	OEM Part Number	Blade Count	Dia.	Pitch	Rot.	Lau Part Number	Lau Pitch
Lennox	P-8-10823	4	19 ³ / ₄ "	30°	CW	60558901	30°
Lennox	P-8-3232	4	24"	28°	CCW	60559801	27°
Lennox	P-8-4478	4	22"	26°	CW	60559301	27°
Lennox	P-8-5795	4	17 ³ / ₄ "	26°	CCW	60558201	27°
Lennox	P-8-6037	4	22"	34°	CW	60559501	33°
Lennox	P-8-6315	4	22"	30°	CCW	60559401	27°
Lennox	P-8-6923	4	16"	26°	CW	60719501	27°
Lennox	P-8-6924	4	18"	23°	CW	60800201	23°
Lennox	P-8-7331	4	19 ³ / ₄ "	26°	CW	60558701	27°
Lennox	P-8-8039	4	24"	30°	CW	60559701	27°
Lennox	P-8-8040	4	24"	34°	CW	60559901	33°
Lennox	229-99-901	5	17 ¹³ / ₁₆ "	35°	CW	60560701	33°
Lennox	P-8-10470	5	18"	34°	CW	60560701	33°
Lennox	2291836	5	18"	34°	CW	60560701	33°
Lennox	P-8-10469	5	18"	31°	CW	60560701	33°
Lennox	57A6601	5	20"	28°	CW	60560901	27°
Lennox	P-8-11201	5	20"	34°	CW	60561101	33°
Lennox	28G5301	5	20"	35°	CCW	60561201	33°
Lennox	P-8-10992	5	22"	28°	CW	60561301	27°
Lennox	P-8-11022	5	22"	25°	CW	60561301	27°
Lennox	P-8-6283	5	26"	29°	CW	60761301	27°
Lennox	7173254	5	26"	26°	CW	60761301	27°
Lennox	22F5401	5	26"	25°	CW	60761301	27°
Lennox	P-8-10546	5	26"	25°	CW	60761301	27°
Lennox	16C0001	3	24"	24°	CW	60557701	27°
Lennox	56L7201	3	24"	30°	CW	60557901	33°
Lennox	5107B	3	14"	23°	CCW	60716601	23°
Lennox	5146C	3	14"	29°	CW	60716701	27°
Lennox	5148C	3	14"	29°	CCW	60716801	27°
Lennox	229-1624	3	16"	25°	CW	60717101	23°
Lennox	11G3901	4	24"	34°	CW	60559901	33°
Lennox	12F2001	4	24"	25°	CW	60804301	23°
Lennox	15F6701	4	24"	22°	CCW	60804401	23°
Lennox	16C0101	4	24"	27°	CW	60559701	27°
Lennox	23G8301	4	24"	25°	CCW	60804401	23°
Lennox	29F8001	4	24"	22°	CW	60804301	23°

While Lau makes every effort to provide accurate and complete information, the recommended propeller replacement is the closest match to Lau stock products. It is up to the individual purchaser to double-check performance to guarantee the correct propeller application. Lau reserves the right to make changes to this catalog, at any time and without notice, to prices, specifications and models and is not responsible for typographical or image errors.

OEM Name	OEM Part Number	Blade Count	Dia.	Pitch	Rot.	Lau Part Number	Lau Pitch
Lennox	32M9401	4	22"	32°	CCW	60559601	33°
Lennox	43G3801	4	22"	28°	CW	60559301	27°
Lennox	45C5101	4	24"	26°	CW	60559701	27°
Lennox	45F5801	4	22"	27°	CW	60559301	27°
Lennox	54G3001	4	24"	24°	CW	60804301	23°
Lennox	68J2701	4	18"	24°	CCW	60800301	23°
Lennox	68J2801	4	18"	34°	CCW	60558601	33°
Lennox	89F4301	4	18"	26°	CCW	60558201	27°
Lennox	95C5901	4	17 ¹³ / ₁₆ "	30°	CW	60558301	30°
Lennox	99C6201	4	17 ³ / ₄ "	20°	CW	60800201	23°
Lennox	P-8-10387	4	19 ³ / ₄ "	22°	CW	60800401	23°
Lennox	P-8-10388	4	19 ³ / ₄ "	34°	CW	60559101	33°
Lennox	P-8-10823	4	19 ³ / ₄ "	30°	CW	60558901	30°
Lennox	P-8-11098	4	20"	27°	CW	60558701	27°
Lennox	P-8-4478	4	22"	26°	CW	60559301	27°
Lennox	P-8-6037	4	22"	34°	CW	60559501	33°
Lennox	P-8-6315	4	22"	30°	CCW	60559401	27°
Lennox	P-8-7331	4	19 ³ / ₄ "	26°	CW	60558701	27°
Lennox	P-8-8038	4	19 ¹³ / ₁₆ "	30°	CW	60558901	30°
Lennox	P-8-10470	5	18"	34°	CW	60560701	33°
Lennox	P-8-10469	5	18"	31°	CW	60560701	33°
Lennox	57A6601	5	20"	28°	CW	60560901	27°
Lennox	P-8-11201	5	20"	34°	CW	60561101	33°
Lennox	28G5301	5	20"	35°	CCW	60561201	33°
Lennox	P-8-10992	5	22"	28°	CW	60561301	27°
Lennox	P-8-11022	5	22"	25°	CW	60561301	27°
Lennox	P-8-6283	5	26"	29°	CW	60761301	27°
Lennox	P-8-10546	5	26"	25°	CW	60761301	27°
Lennox	68J2601	3	18"	26°	CCW	60556201	27°
Lennox	16C0001	3	24"	24°	CW	60557701	27°
Lennox	99K4501	3	24"	28°	CW	60557701	27°
Lennox	T6-2115	5	16"	34°	CW	60560301	33°
Liebert Corp.	159112P1	4	20"	22°	CCW	60800501	23°
Liebert Corp.	159112P2	4	20"	26°	CCW	60558801	27°
Liebert Corp.	159241P1	4	24"	24°	CCW	60804401	23°
Liebert Corp.	159241P2	4	24"	28°	CCW	60559801	27°

While Lau makes every effort to provide accurate and complete information, the recommended propeller replacement is the closest match to Lau stock products. It is up to the individual purchaser to double-check performance to guarantee the correct propeller application. Lau reserves the right to make changes to this catalog, at any time and without notice, to prices, specifications and models and is not responsible for typographical or image errors.

APPENDIX D



OEM Cross Reference

OEM Name	OEM Part Number	Blade Count	Dia.	Pitch	Rot.	Lau Part Number	Lau Pitch
Liebert Corp.	D67-002A	4	24"	29°	CW	60559701	27°
Liebert Corp.	154565P1	5	26"	24°	CW	60761301	27°
Liebert Corp.	169144P1	5	26"	24°	CW	60761301	27°
Liebert Corp.	155364P1	5	26"	24°	CW	60761301	27°
Liebert Corp.	148229P1	3	18"	26°	CW	60556101	27°
Liebert Corp.	1C21119P1	3	18"	32°	CCW	60556601	33°
Liebert Corp.	148230P1	3	20"	24°	CW	60556701	27°
Liebert Corp.	1C21120P1	3	20"	25°	CW	60556701	27°
Liebert Corp.	D016A	3	22"	25°	CW	60557301	27°
Liebert Corp.	148231P1	3	24"	24°	CW	60557701	27°
Liebert Corp.	127914P1	3	24"	24°	CW	60557701	27°
Liebert Corp.	159189P2	2	20"	28°	CCW	60772601	28°
Lincoln Electric	M6819-4A	4	12"	30°	CW	60718301	27°
Lincoln Electric	M6819-6	4	16"	23°	CW	60719301	23°
Lincoln Electric	M6819-7	4	16"	20°	CW	60719101	19°
Lincoln Electric	M6819-9	4	16"	25°	CW	60719301	23°
Lincoln Electric	M6819-8	3	16"	17°	CW	60716901	19°
Lincoln Electric	9SM6819-6	4	16"	23°	CW	60719301	23°
Lincoln Electric	M6819-4A	4	12"	30°	CW	60718301	27°
Loren Cook	120532	5	16"	25°	CW	60560101	27°
Loren Cook	120531	5	12"	25°	CW	60720701	27°
Loren Cook	120533	5	20"	25°	CW	60560901	27°
LRC Coil	2191	4	24"	30°	CW	60559701	27°
LRC Coil	02-1265	4	12"	27°	CW	60718301	27°
LRC Coil	02-1282	4	12"	23°	CCW	60718201	23°
LRC Coil	02-1283	4	12"	27°	CCW	60718401	27°
LRC Coil	02-1286	4	14"	27°	CCW	60719001	27°
Mammoth Inc.	6673070	4	26"	28°	CW	60760901	27°
Mammoth Inc.	6673080	4	26"	30°	CW	60760901	27°
Mammoth Inc.	6671481	3	20"	30°	CW	60556901	30°
Mammoth Inc.	667308-A	4	26"	30°	CW	60760901	27°
Mammoth Inc.	305617012-0	5	18"	36°	CW	60560701	33°
Mammoth Inc.	6672190	5	20"	34°	CCW	60561201	33°
Mammoth Inc.	667163-A	3	22"	24°	CW	60557301	27°
Marley Electric Heating	490019002	3	12"	22°	CW	60716301	23°
Marley Electric Heating	490011001	3	12"	25°	CW	60716301	23°

While Lau makes every effort to provide accurate and complete information, the recommended propeller replacement is the closest match to Lau stock products. It is up to the individual purchaser to double-check performance to guarantee the correct propeller application. Lau reserves the right to make changes to this catalog, at any time and without notice, to prices, specifications and models and is not responsible for typographical or image errors.

OEM Name	OEM Part Number	Blade Count	Dia.	Pitch	Rot.	Lau Part Number	Lau Pitch
Marley Electric Heating	1210-0098-000	3	16"	25°	CCW	60717201	23°
Marley Electric Heating	490020000	4	14"	30°	CW	60718901	27°
Marley Electric Heating	490022000	4	16"	24°	CW	60719301	23°
Marley Electric Heating	490011001	3	12"	25°	CW	60716301	23°
Marvair Corp.	30121	4	20"	27°	CW	60558701	27°
Marvair Corp.	30147	4	24"	27°	CW	60559701	27°
Marvair Corp.	4130147	4	24"	27°	CW	60559701	27°
Master-Bilt Products	15-00596	4	12"	23°	CW	60718101	23°
Master-Bilt Products	15-13071	4	24"	28°	CW	60559701	27°
Master-Bilt Products	15-13114	3	18"	26°	CCW	60556201	27°
Master-Bilt Products	15-13113	3	14"	28°	CCW	60716801	27°
Maxon Corp.	25401	4	12"	34°	CW	60760101	33°
McQuay International	029218501	4	24"	28°	CW	60559701	27°
McQuay International	029218600	4	24"	28°	CCW	60559801	27°
McQuay International	048446003	4	24"	30°	CCW	60559801	27°
McQuay International	735023716	4	24"	26°	CCW	60559801	27°
McQuay International	735023717	4	24"	24°	CCW	60804401	23°
McQuay International	735023721	4	24"	30°	CCW	60559801	27°
McQuay International	071205801	5	26"	30°	CW	60761301	27°
McQuay International	074814702	5	28	36°	CW	60761501	33°
McQuay International	073061401	5	28	32°	CW	60761501	33°
McQuay International	073061402	5	28	32°	CW	60761501	33°
McQuay International	049121701	3	24"	27°	CW	60557701	27°
McQuay International	071205901	3	24"	26°	CCW	60557801	27°
McQuay International	049121702	3	24"	30°	CW	60557901	33°
McQuay International	036565700	2	24"	25°	CCW	60778201	27°
McQuay International	29218501	4	24"	28°	CW	60559701	27°
McQuay International	71402201	4	22"	31°	CCW	60559601	33°
McQuay International	71205801	5	26"	30°	CW	60761301	27°
McQuay International	60013101	5	26"	28°	CW	60761301	27°
Mestek Inc.	872112030	4	12"	25°	CW	60718101	23°
Mestek Inc.	11J34-00321-009	4	24"	24°	CW	60804301	23°
Mestek Inc.	11J34-00321-016	4	20"	26°	CW	60558701	27°
Mestek Inc.	11J34-00321-018	4	16"	35°	CW	60760501	33°
Mestek Inc.	11J34-00321-019	4	18"	35°	CW	60558501	33°
Mestek Inc.	11J34-00321-022	4	16"	30°	CW	60719501	27°

While Lau makes every effort to provide accurate and complete information, the recommended propeller replacement is the closest match to Lau stock products. It is up to the individual purchaser to double-check performance to guarantee the correct propeller application. Lau reserves the right to make changes to this catalog, at any time and without notice, to prices, specifications and models and is not responsible for typographical or image errors.

APPENDIX D



OEM Cross Reference

OEM Name	OEM Part Number	Blade Count	Dia.	Pitch	Rot.	Lau Part Number	Lau Pitch
Mestek Inc.	11J34-04767-001	4	10"	30°	CW	60759901	33°
Mestek Inc.	11J34-04767-002	4	16"	20°	CW	60719101	19°
Mestek Inc.	BUILT IN MEXICO	4	18"	34°	CW	60558501	33°
Mestek Inc.	BUILT IN MEXICO	4	14"	34°	CW	60760301	33°
Mestek Inc.	BUILT IN MEXICO (REPLACEMENT)	4	16"	34°	CW	60760501	33°
Mestek Inc.	52500028	3	10"	24°	CW	60265201	27°
Mestek Inc.	11J34-00321-015	3	18"	25°	CW	60556101	27°
Mestek Inc.	52500057	3	18"	27°	CW	60556101	27°
Mestek Inc.	11J34-00321-007	3	18"	28°	CW	60556101	27°
Mestek Inc.	52500015	3	18"	29°	CW	60556301	30°
Mestek Inc.	52500056	3	18"	33°	CW	60556501	33°
Mestek Inc.	52500019	3	20"	30°	CW	60556901	30°
Mestek Inc.	52500020	3	24"	24°	CW	60557701	27°
Mestek Inc.	52500021	3	24"	27°	CW	60557701	27°
Mestek Inc.	52500063	3	12"	24°	CW	60716301	23°
Mestek Inc.	52500023	3	12"	24°	CW	60716301	23°
Mestek Inc.	11J34-00321-001	3	12"	26°	CW	60716301	23°
Mestek Inc.	52500027	3	14"	24°	CW	60716501	23°
Mestek Inc.	11J34-00321-002	3	14"	28°	CW	60716701	27°
Mestek Inc.	52500009	3	16"	23°	CW	60717101	23°
Mestek Inc.	11J34-00321-011	3	16"	24°	CW	60717101	23°
Mestek Inc.	11J34-04767-001	4	10"	30°	CW	60759901	33°
Mestek Inc.	11J34-04767-002	4	16"	20°	CW	60719101	19°
Mestek Inc.	11J34-05943	4	14"	34°	CW	60760301	33°
Mestek Inc.	11J34-05944	4	16"	34°	CW	60760501	33°
Mestek Inc.	11J34-05945	4	16"	32°	CW	60760501	33°
Mestek Inc.	11J34-05946	4	18"	34°	CW	60558501	33°
Mestek Inc.	11J34-00321-001	3	12"	26°	CW	60716301	23°
Mestek Inc.	11J34-00321-002	3	14"	28°	CW	60716701	27°
Metal-Fab	P1238	4	12"	30°	CCW	60718401	27°
Metal-Fab	P3176	4	12"	30°	CW	60718301	27°
Metal-Fab	P2292	5	16"	25°	CCW	60560201	27°
Metal-Fab	P1200	5	18"	24°	CCW	60560601	27°
Miller Electric	032613	3	18"	26°	CW	60556101	27°
Miller Electric	032617	3	20"	25°	CW	60556701	27°

While Lau makes every effort to provide accurate and complete information, the recommended propeller replacement is the closest match to Lau stock products. It is up to the individual purchaser to double-check performance to guarantee the correct propeller application. Lau reserves the right to make changes to this catalog, at any time and without notice, to prices, specifications and models and is not responsible for typographical or image errors.

OEM Name	OEM Part Number	Blade Count	Dia.	Pitch	Rot.	Lau Part Number	Lau Pitch
Miller Electric	032611	3	14"	23°	CCW	60716601	23°
Miller Electric	605799	5	14"	29°	CW	60721301	27°
Miller Electric	032612	4	12"	23°	CCW	60718201	23°
Miller Electric	032614	4	12"	25°	CCW	60718201	23°
Modine	3H0362110001	3	24"	24°	CW	60557701	27°
Modine	BPF01168-2	3	24"	26°	CW	60557701	27°
Modine	BPF01168-3	3	24"	28°	CW	60557701	27°
Modine	BPF01168-4	3	24"	30°	CW	60557901	33°
Modine	5H0630400004	4	20"	23°	CW	60800401	23°
Modine	5H0731360005	5	22"	34°	CW	60561501	33°
NBC Products	202280	4	18"	24°	CCW	60800301	23°
NBC Products	202280	4	18"	24°	CW	60800201	23°
NBC Products	196205	5	18"	24°	CCW	60560601	27°
New Holland	130219	3	12"	20°	CCW	60716201	19°
New York Blower	94-0005	4	16"	29°	CW	60719501	27°
New York Blower	94-0015	4	16"	29°	CCW	60719601	27°
New York Blower	94-0126	4	24"	28°	CW	60559701	27°
New York Blower	94-0135	4	24"	23°	CCW	60804401	23°
New York Blower	94-0120	4	14"	31°	CW	60760301	33°
New York Blower	94-0122	4	18"	22°	CW	60800201	23°
New York Blower	94-0125	4	24"	23°	CW	60804301	23°
New York Blower	94-0130	4	14"	31°	CCW	60760401	33°
New York Blower	94-0132	4	18"	22°	CCW	60800301	23°
Nordyne	6673070	4	26"	28°	CW	60760901	27°
Nordyne	6673080	4	26"	30°	CW	60760901	27°
Nordyne	6671481	3	20"	30°	CW	60556901	30°
Nordyne	667308	4	26"	30°	CW	60760901	27°
Nordyne	667308-A	4	26"	30°	CW	60760901	27°
Nordyne	305617012-0	5	18"	36°	CW	60560701	33°
Nordyne	6672190	5	20"	34°	CCW	60561201	33°
Nordyne	667163-A	3	22"	24°	CW	60557301	27°
Nu-Tone	67179000	3	14"	25°	CCW	60716601	23°
Patton Refrigeration	N24-4-26-R-5/8	4	24"	26°	CW	60559701	27°
Patton Refrigeration	N20-5-35-R-5/8	5	20"	35°	CW	60561101	33°
Patton Refrigeration	N24-5-24-R-5/8	5	24"	25°	CW	60561701	27°
Patton Refrigeration	N20-5-35-R	5	20"	35°	CW	60561101	33°

While Lau makes every effort to provide accurate and complete information, the recommended propeller replacement is the closest match to Lau stock products. It is up to the individual purchaser to double-check performance to guarantee the correct propeller application. Lau reserves the right to make changes to this catalog, at any time and without notice, to prices, specifications and models and is not responsible for typographical or image errors.

APPENDIX D



OEM Cross Reference

OEM Name	OEM Part Number	Blade Count	Dia.	Pitch	Rot.	Lau Part Number	Lau Pitch
Patton Refrigeration	N24-5-24R-5/8	5	24"	25°	CW	60561701	27°
Pool Fact	98-10028	3	18"	30°	CW	60556301	30°
Pool Fact	82-10558	3	18"	30°	CCW	60556401	30°
Portage Transformer	FF-1430	4	14"	30°	CW	60718901	27°
Post Agri Supply	0904040-0	3	16"	24°	CCW	60717201	23°
Powrmatic	11-0035	4	16"	20°	CW	60719101	19°
Powrmatic	11-004	4	16"	30°	CW	60719501	27°
Powrmatic	11-0050	4	18"	26°	CW	60558101	27°
Powrmatic	11-0060	4	20"	22°	CW	60800401	23°
Powrmatic	11-0064	4	16"	36°	CW	60760501	33°
Quietaire	41833CWI	4	18"	33°	CW	60558501	33°
RAE Corp.	C03005-14	4	20"	29°	CW	60558901	30°
RAE Corp.	C03005-15	4	20"	29°	CCW	60559001	30°
RAE Corp.	C03008-01	4	20"	22°	CW	60800401	23°
Randell Manufacturing	61118501	3	14"	20°	CW	60716501	23°
Randell Manufacturing	RFBLD9904	3	14"	20°	CW	60716501	23°
Rapid Power Tech	46-020	4	18"	25°	CCW	60800301	23°
Rapid Power Tech	46-049	5	24"	27°	CCW	60561801	27°
Red Dot Corp.	RD-4-3508-0REV.A	4	10"	22°	CW	60717501	23°
Red Dot Corp.	RD-4-3508-0P	4	10"	22°	CW	60717501	23°
Refplus (Dectron)	RFN0040	4	20"	34°	CW	60559101	33°
Refplus (Dectron)	RFN0041	4	20"	34°	CW	60559101	33°
Refrigeration Industries	3202617000	4	15 ³ / ₄ "	27°	CCW	60719601	27°
Refrigeration Industries	03202641B000	3	18"	27°	CCW	60556201	27°
Refrigeration Industries	03202621B000	3	24"	28°	CW	60557701	27°
Refrigeration Industries	03202634B000	3	24"	34°	CW	60557901	33°
Refrigeration Industries	03202664B000	4	22"	30°	CCW	60559401	27°
Refrigeration Industries	03202609000	3	20"	26°	CW	60556701	27°
Refrigeration Industries	03202623B000	3	24"	25°	CW	60557701	27°
Reznor	96380	4	16"	36°	CW	60760501	33°
Reznor	96381	4	20"	23°	CW	60800401	23°
Reznor	96383	4	22"	35°	CW	60559501	33°
Reznor	96384	4	24"	35°	CW	60559901	33°
Reznor	125564	4	17 ¹ / ₂ "	29°	CW	60558301	30°
Reznor	125566	4	15 ¹ / ₂ "	31°	CW	60760501	33°

While Lau makes every effort to provide accurate and complete information, the recommended propeller replacement is the closest match to Lau stock products. It is up to the individual purchaser to double-check performance to guarantee the correct propeller application. Lau reserves the right to make changes to this catalog, at any time and without notice, to prices, specifications and models and is not responsible for typographical or image errors.

OEM Name	OEM Part Number	Blade Count	Dia.	Pitch	Rot.	Lau Part Number	Lau Pitch
Reznor	177223	5	24"	26°	CW	60561701	27°
Reznor	150838	5	24"	36°	CW	60561901	33°
Reznor	157058	5	24"	34°	CW	60561901	33°
Reznor	45529	3	12"	25°	CCW	60716401	23°
Reznor	17909	3	14"	27°	CW	60716701	27°
Reznor	208976	5	24"	34°	CW	60561901	33°
Reznor	209122	3	24"	28°	CCW	60557801	27°
Reznor	209121	3	24"	33°	CCW	60558001	33°
Rheem	70-17758-01	3	18"	27°	CW	60556101	27°
Rheem	70-17845-01	3	20"	31°	CW	60556901	30°
Rheem	70-42484-01	3	24"	25°	CCW	60557801	27°
Rheem	70-19799-01	4	20"	36°	CW	60559101	33°
Rheem	70-17518-06	5	18"	33°	CCW	60561201	33°
Rheem	70-21858-12	2	18"	27°	CCW	60772501	28°
Rheem	70-20624-01	2	20"	28°	CCW	60772601	28°
Rheem	70-20558-03	2	22"	16°	CCW	60772701	16°
Rheem	75-70-20558-03	2	22"	16°	CCW	60772701	16°
Rheem	70-19799-01	4	20"	36°	CW	60559101	33°
Rheem	70-42484-01	3	24"	25°	CCW	60557801	27°
Rheem	70-100580-04	3	24"	28°	CCW	60557801	27°
Rheem	70-21858-12	2	18"	27°	CCW	60772501	28°
Rheem	70-20558-03	2	22"	16°	CCW	60772701	16°
Rheem	70-100580-07	2	22"	28°	CCW	60814201	27°
Rheem	70-21858-10	3	18"	30°	CCW	60556401	30°
Rheem	70-17758-01	3	18"	27°	CW	60556101	27°
Rheem	70-17845-01	3	20"	31°	CW	60556901	30°
Rheem	70-41799-01	3	22"	30°	CCW	60557401	27°
Rheem	70-24281-01	3	16"	25°	CW	60717101	23°
Rheem	70-23594-02	3	22"	24°	CCW	60557401	27°
Rheem	70-24281-02	4	18"	22°	CW	60800201	23°
Rheem	70-24281-03	4	20"	25°	CW	60800401	23°
Rheem	70-24281-04	4	18"	24°	CW	60800201	23°
Rheem	70-42497-02	4	24"	23°	CW	60804301	23°
Rheem	70-42497-03	4	24"	28°	CW	60559701	27°
Rheem	70-17520-02	5	16"	33°	CCW	60560401	33°
Rheem	70-17518-06	5	18"	33°	CCW	60561201	33°

While Lau makes every effort to provide accurate and complete information, the recommended propeller replacement is the closest match to Lau stock products. It is up to the individual purchaser to double-check performance to guarantee the correct propeller application. Lau reserves the right to make changes to this catalog, at any time and without notice, to prices, specifications and models and is not responsible for typographical or image errors.

APPENDIX D



OEM Cross Reference

OEM Name	OEM Part Number	Blade Count	Dia.	Pitch	Rot.	Lau Part Number	Lau Pitch
Rheem	70-21858-12	2	18"	27°	CCW	60772501	28°
Rheem	70-20624-01	2	20"	28°	CCW	60772601	28°
Rheem	70-20558-03	2	22"	16°	CCW	60772701	16°
Rheem	70-21858-07	2	24"	24°	CCW	60778201	27°
Robur Corp.	14891-27	4	26"	28°	CW	60760901	27°
Robur Corp.	B14891-21	4	26"	32°	CW	60761101	33°
Rome Industrial	100-044	4	24"	22°	CW	60804301	23°
Rome Industrial	100-201	4	24"	24°	CW	60804301	23°
Rome Industrial	400-003	3	20"	30°	CW	60556901	30°
Roth Manufacturing	FFP-20	3	20"	24°	CW	60556701	27°
Roth Manufacturing	FFP-20	3	20"	24°	CW	60556701	27°
Ruffneck Heaters	8303	4	20"	23°	CW	60800401	23°
Ruffneck Heaters	4026	3	20"	24°	CW	60556701	27°
Ruffneck Heaters	4023	3	12"	20°	CW	60716101	19°
Ruffneck Heaters	4024	3	16"	16°	CW	60716901	19°
Ruffneck Heaters	5449	3	16"	20°	CW	60716901	19°
Rupp Industries	83100.005	4	10"	32°	CCW	60760001	33°
Rupp Industries	83100.166	4	14"	30°	CW	60718901	27°
Rupp Industries	83100.015	3	18"	25°	CW	60556101	27°
Rupp Industries	83100.020	3	22"	24°	CW	60557301	27°
Rupp Industries	83100.02	3	22"	24°	CW	60557301	27°
Russell Coil	213155000	4	24"	29°	CW	60559701	27°
Russell Coil	213156000	4	20"	29°	CW	60558901	30°
Russell Coil	214100000	4	14"	32°	CW	60760301	33°
Russell Coil	214114000	4	24"	28°	CW	60559701	27°
Russell Coil	213456-000	3	20"	25°	CW	60556701	27°
Russell Coil	213266000	3	24"	28°	CCW	60557801	27°
Russell Coil	213455000	3	24"	32°	CW	60557901	33°
Russell Coil	215112-000	3	12"	23°	CW	60716301	23°
Ruud	70-17758-01	3	18"	27°	CW	60556101	27°
Ruud	70-17845-01	3	20"	31°	CW	60556901	30°
Ruud	70-42484-01	3	24"	25°	CCW	60557801	27°
Ruud	70-19799-01	4	20"	36°	CW	60559101	33°
Ruud	70-17518-06	5	18"	33°	CCW	60561201	33°
Ruud	70-21858-12	2	18"	27°	CCW	60772501	28°
Ruud	70-20624-01	2	20"	28°	CCW	60772601	28°

While Lau makes every effort to provide accurate and complete information, the recommended propeller replacement is the closest match to Lau stock products. It is up to the individual purchaser to double-check performance to guarantee the correct propeller application. Lau reserves the right to make changes to this catalog, at any time and without notice, to prices, specifications and models and is not responsible for typographical or image errors.

OEM Name	OEM Part Number	Blade Count	Dia.	Pitch	Rot.	Lau Part Number	Lau Pitch
Ruud	70-20558-03	2	22"	16°	CCW	60772701	16°
Schaefer Fan	AFB-203	3	20"	24°	CW	60556701	27°
Schaefer Fan	AFB-163SF	3	16"	16°	CW	60716901	19°
Schreiber Engineering	E149	3	24"	27°	CW	60557701	27°
Schreiber Engineering	E148-30	5	18"	30°	CW	60560501	27°
Taylor-Winfield	FF-1430	4	14"	30°	CW	60718901	27°
TDM International	TBA	5	22"	34°	CW	60561501	33°
Tecam	22311121	4	12"	24°	CCW	60718201	23°
Tecumseh Products	5151824A02	4	18"	23°	CW	60800201	23°
Tecumseh Products	5151828A01	4	18"	27°	CW	60558101	27°
Thermal Arc	404887	4	12"	22°	CW	60718101	23°
Thermal Arc	406991	4	14"	25°	CCW	60718801	23°
Thermal Arc	8RT609	4	12"	22°	CCW	60718201	23°
Thermal Arc	404887	4	12"	22°	CW	60718101	23°
Thermal Arc	22X523	5	18"	36°	CW	60560701	33°
Thermal Arc	22X635	3	12"	25°	CW	60716301	23°
Thermal Arc	22X393	3	16"	20°	CCW	60717001	19°
Thermal Care	9611311	4	14"	36°	CW	60760301	33°
Thermal Care	9611313	4	18"	36°	CW	60558501	33°
Thermal Dynamics Corp.	22X257	4	16"	28°	CW	60719501	27°
Thermal Dynamics Corp.	520-046	4	12"	25°	CCW	60718201	23°
Thermal Dynamics Corp.	8RT609	4	12"	22°	CCW	60718201	23°
Thermal Dynamics Corp.	22X523	5	18"	36°	CW	60560701	33°
Thermal Dynamics Corp.	22X635	3	12"	25°	CW	60716301	23°
Thermal Dynamics Corp.	22X393	3	16"	20°	CCW	60717001	19°
Thermal Transfer Products	65356	4	10"	35°	CW	60759901	33°
Thermal Transfer Products	65398	4	18"	28°	CW	60558101	27°
Thermal Transfer Products	65498	4	10"	30°	CW	60759901	33°
Thermal Transfer Products	65499	4	18"	24°	CW	60800201	23°
Thermal Transfer Products	65639	4	18"	33°	CW	60558501	33°
Thermal Transfer Products	65640	4	20"	26°	CW	60558701	27°
Thermal Transfer Products	66941	4	20"	26°	CCW	60558801	27°
Thermal Transfer Products	65500	3	20"	24°	CW	60556701	27°
Thermal Transfer Products	65424	3	20"	27°	CW	60556701	27°
Thermal Transfer Products	65534	3	20"	33°	CW	60557101	33°
Thermal Transfer Products	65425	3	22"	28°	CW	60557301	27°

While Lau makes every effort to provide accurate and complete information, the recommended propeller replacement is the closest match to Lau stock products. It is up to the individual purchaser to double-check performance to guarantee the correct propeller application. Lau reserves the right to make changes to this catalog, at any time and without notice, to prices, specifications and models and is not responsible for typographical or image errors.

APPENDIX D



OEM Cross Reference

OEM Name	OEM Part Number	Blade Count	Dia.	Pitch	Rot.	Lau Part Number	Lau Pitch
Thermal Transfer Products	66468	3	12"	24°	CW	60716301	23°
Thermal Transfer Products	65374	3	12"	24°	CW	60716301	23°
Thermal Transfer Products	65394	3	14"	26°	CW	60716701	27°
Thermo King	21S091	5	16"	27°	CW	60560101	27°
Thermo King	21S91	5	16"	27°	CW	60560101	27°
Thermo King	E315709	3	22"	36°	CCW	60557601	33°
Thermo King	21S92	3	16"	22°	CW	60717101	23°
Thermo King	0251098	5	16"	27°	CW	60560101	27°
Thermo King	97333512	3	20"	35°	CCW	60557201	33°
Thermo King	54366844	3	22"	35°	CCW	60557601	33°
Thermo King	81295222	3	16"	19°	CW	60716901	19°
Thermo King	F0102800	4	20"	34°	CW	60559101	33°
Thermo King	F0102900	4	20"	34°	CW	60559101	33°
Thermo King	11252	4	21 ³ / ₄ "	27°	CW	60559301	27°
Thermo King	11259	4	21 ³ / ₄ "	27°	CCW	60559401	27°
Thermo King	11267	4	21 ³ / ₄ "	31°	CCW	60559601	33°
Thermo King	11269	4	17 ³ / ₄ "	29°	CW	60558301	30°
Thermo King	11285	4	24"	31°	CCW	60560001	33°
Thermo King	0048120	4	18"	32°	CW	60558501	33°
Thermo King	BF0102800	4	20"	34°	CW	60559101	33°
Thermo King	E205692	4	19 ³ / ₄ "	32°	CW	60559101	33°
Thermo King	54364641	4	16"	22°	CW	60719301	23°
Thermo King	11251	4	21 ¹³ / ₁₆ "	21°	CW	60804101	23°
Thermo King	3095C43G01	4	16"	22°	CW	60719301	23°
Thermo King Corp.	X3801008701	2	18"	28°	CCW	60772501	28°
Thermo King Corp.	4639C03G01	2	18"	30°	CCW	60772501	28°
Thermo King Corp.	4639C03G05	2	18"	30°	CCW	60772501	28°
Thermo King Corp.	4639C03G06	2	18"	30°	CCW	60772501	28°
Thermo King Corp.	3045C82G01	2	24"	26°	CCW	60778201	27°
Thermo Pride	340322	3	20"	30°	CCW	60557001	30°
Thermo Pride	340323	3	22"	24°	CCW	60557401	27°
Thermo Pride	340325	3	22"	30°	CCW	60557401	27°
Thermo Products	340322	3	20"	30°	CCW	60557001	30°
Thermo Products	340323	3	22"	24°	CCW	60557401	27°
Thermoplus Air	RFN0040	4	20"	34°	CW	60559101	33°
Thermoplus Air	RFN-0041	4	20"	34°	CW	60559101	33°

While Lau makes every effort to provide accurate and complete information, the recommended propeller replacement is the closest match to Lau stock products. It is up to the individual purchaser to double-check performance to guarantee the correct propeller application. Lau reserves the right to make changes to this catalog, at any time and without notice, to prices, specifications and models and is not responsible for typographical or image errors.

OEM Name	OEM Part Number	Blade Count	Dia.	Pitch	Rot.	Lau Part Number	Lau Pitch
Thermotron Industries	603082	4	12"	23°	CW	60718101	23°
Thermotron Industries	603120	4	16"	23°	CW	60719301	23°
Thermotron Industries	603139	4	18"	23°	CW	60800201	23°
Thermotron Industries	994928	4	20"	34°	CW	60559101	33°
Thermotron Industries	603112	5	14"	29°	CW	60721301	27°
Thermotron Industries	994928	4	20"	34°	CW	60559101	33°
Thermotron Industries	1010090	5	16"	30°	CW	60560101	27°
Thomas & Betts	31878	4	14"	25°	CW	60718701	23°
Thomas & Betts	96380	4	16"	36°	CW	60760501	33°
Thomas & Betts	96383	4	22"	35°	CW	60559501	33°
Thomas & Betts	125564	4	17½"	29°	CW	60558301	30°
Thomas & Betts	125566	4	15½"	31°	CW	60760501	33°
Thomas & Betts	177223	5	24"	26°	CW	60561701	27°
Thomas & Betts	150838	5	24"	36°	CW	60561901	33°
Thomas & Betts	157058	5	24"	34°	CW	60561901	33°
Thomas & Betts	45529	3	12"	25°	CCW	60716401	23°
Thomas & Betts	17909	3	14"	27°	CW	60716701	27°
Thomas & Betts	208976	5	24"	34°	CW	60561901	33°
Thomas & Betts	209122	3	24"	28°	CCW	60557801	27°
Thomas & Betts	209121	3	24"	33°	CCW	60558001	33°
Thomas & Betts	096381	4	20"	23°	CW	60800401	23°
Thomas & Betts	096382	4	22"	25°	CW	60559301	27°
Thomas & Betts	096384	4	24"	35°	CW	60559901	33°
Thomas & Betts	150838	5	24"	36°	CW	60561901	33°
TPI Corp.	51555-001	4	12"	30°	CW	60718301	27°
TPI Corp.	57115-001	4	16"	30°	CW	60719501	27°
TPI Corp.	61772-001	4	14"	30°	CW	60718901	27°
TPI Corp.	57114-001	3	16"	24°	CW	60717101	23°
TPI Corp.	62033-002	3	16"	26°	CW	60717101	23°
Trane	B729628P01	3	18"	29°	CW	60556301	30°
Trane	C669226P01	3	18"	29°	CW	60556301	30°
Trane	B728888P01	3	22"	32°	CW	60557501	33°
Trane	X38010371010	3	24"	28°	CW	60557701	27°
Trane	C669226PO1	3	18"	29°	CW	60556301	30°
Trane	C669031P02	3	20"	34°	CW	60557101	33°
Trane	B728888P02	3	22"	32°	CW	60557501	33°

While Lau makes every effort to provide accurate and complete information, the recommended propeller replacement is the closest match to Lau stock products. It is up to the individual purchaser to double-check performance to guarantee the correct propeller application. Lau reserves the right to make changes to this catalog, at any time and without notice, to prices, specifications and models and is not responsible for typographical or image errors.

APPENDIX D



OEM Cross Reference

OEM Name	OEM Part Number	Blade Count	Dia.	Pitch	Rot.	Lau Part Number	Lau Pitch
Trane	X38010371010	3	24"	28°	CW	60557701	27°
Trane	C669226P01	3	18"	29°	CW	60556301	30°
Trane	C669031P01	3	20"	32°	CW	60557101	33°
Trane	MEXICO	4	26"	32°	CW	60761101	33°
Trane	X38010311010	4	18"	26°	CW	60558101	27°
Trane	X38010312017	4	18"	27°	CW	60558101	27°
Trane	X38010312027	4	18"	35°	CW	60558501	33°
Trane	X38010312037	4	18"	34°	CW	60558501	33°
Trane	X38010315017	4	20"	28°	CW	60558701	27°
Trane	X38010315027	4	20"	28°	CW	60558701	27°
Trane	X38010317017	4	22"	36°	CW	60559501	33°
Trane	X38010317027	4	22"	34°	CW	60559501	33°
Trane	X38010317047	4	22"	30°	CW	60559301	27°
Trane	X38010317057	4	22"	26°	CW	60559301	27°
Trane	X38010318017	4	24"	33°	CW	60559901	33°
Trane	X38010323017	4	22"	30°	CW	60559301	27°
Trane	X38010333-01	4	26"	32°	CW	60761101	33°
Trane	X38010333010	4	26"	32°	CW	60761101	33°
Trane	X38010333020	4	26"	32°	CW	60761101	33°
Trane	X38010338060	4	22"	34°	CW	60559501	33°
Trane	X38010342050	4	18"	32°	CW	60558501	33°
Trane	X38010344010	4	22"	34°	CW	60559501	33°
Trane	X38010358020	4	22"	32°	CCW	60559601	33°
Trane	X38010365010	4	26"	24°	CW	60760701	24°
Trane	X38010365020	4	26"	24°	CCW	60760801	24°
Trane	X38010396010	4	26"	32°	CW	60761101	33°
Trane	X38010319017	5	24"	32°	CW	60561901	33°
Trane	X38010320027	5	26"	30°	CW	60761301	27°
Trane	X38010321017	5	26"	28°	CW	60761301	27°
Trane	X38010320017	5	26"	26°	CW	60761301	27°
Trane	X38010390030	3	18"	24°	CW	60556101	27°
Trane	B139194P07	3	18"	26°	CCW	60556201	27°
Trane	X38010341060	3	18"	29°	CW	60556301	30°
Trane	X38010368020	3	18"	29°	CW	60556301	30°
Trane	B139194P03	3	18"	29°	CCW	60556401	30°
Trane	X38010357030	3	18"	29°	CCW	60556401	30°

While Lau makes every effort to provide accurate and complete information, the recommended propeller replacement is the closest match to Lau stock products. It is up to the individual purchaser to double-check performance to guarantee the correct propeller application. Lau reserves the right to make changes to this catalog, at any time and without notice, to prices, specifications and models and is not responsible for typographical or image errors.

OEM Name	OEM Part Number	Blade Count	Dia.	Pitch	Rot.	Lau Part Number	Lau Pitch
Trane	X38010390040	3	18"	32°	CW	60556501	33°
Trane	X55010006620	3	18"	35°	CW	60556501	33°
Trane	X38010359110	3	18"	34°	CCW	60556601	33°
Trane	B139194P09	3	18"	34°	CCW	60556601	33°
Trane	X38010359090	3	18"	34°	CCW	60556601	33°
Trane	X38010313027	3	20"	26°	CW	60556701	27°
Trane	X38010314017	3	20"	32°	CW	60557101	33°
Trane	B139194P06	3	22"	24°	CCW	60557401	27°
Trane	X38010357040	3	22"	25°	CCW	60557401	27°
Trane	X38010350010	3	22"	34°	CW	60557501	33°
Trane	B139194P01	3	22"	31°	CCW	60557601	33°
Trane	X38010357010	3	22"	31°	CCW	60557601	33°
Trane	X38010372-01	3	24"	31°	CW	60557901	33°
Trane	X38010372010	3	24"	31°	CW	60557901	33°
Trane	X38020441260	3	14"	25°	CCW	60716601	23°
Trane	X38010357020	3	14"	26°	CCW	60716801	27°
Trane	X38020441300	3	14"	26°	CCW	60716801	27°
Trane	B139194P02	3	14"	29°	CCW	60716801	27°
Trane	X38010390010	3	16"	24°	CW	60717101	23°
Trane	X38010360020	2	18"	36°	CCW	60652101	33°
Trane	X38010367010	2	18"	36°	CCW	60652101	33°
Trane	X38010361020	2	14"	36°	CW	60743401	36°
Trane	X38010360030	2	22"	26°	CCW	60814201	27°
Trane	X55010229130	4	18"	34°	CW	60558501	33°
Trane	X38010458010	3	22"	24°	CCW	60557401	27°
Trane	X38010357060	3	22"	24°	CCW	60557401	27°
Trane	X38010459010	3	22"	26°	CCW	60557401	27°
Trane	D153886P30	3	14"	26°	CCW	60716801	27°
Trane	X38010457010	2	22"	30°	CCW	60814201	27°
Trane	X38010215010	4	26"	32°	CW	60761101	33°
Trane	38010396-001	4	26"	32°	CW	60761101	33°
Trion	140551001	4	18"	34°	CCW	60558601	33°
Trion	136333-001	5	16"	33°	CCW	60560401	33°
Trion	140552-001	5	18"	26°	CCW	60560601	27°
TTI	M003	3	22"	25°	CCW	60557401	27°
Tyler Refrigeration	59310540	3	16"	25°	CCW	60717201	23°

While Lau makes every effort to provide accurate and complete information, the recommended propeller replacement is the closest match to Lau stock products. It is up to the individual purchaser to double-check performance to guarantee the correct propeller application. Lau reserves the right to make changes to this catalog, at any time and without notice, to prices, specifications and models and is not responsible for typographical or image errors.

APPENDIX D



OEM Cross Reference

OEM Name	OEM Part Number	Blade Count	Dia.	Pitch	Rot.	Lau Part Number	Lau Pitch
Unifin International	1770996	5	26"	25°	CW	60761301	27°
Unifin International	12200103	5	26"	31°	CW	60761501	33°
Unifin International	1770996	5	26"	25°	CW	60761301	27°
Unifin International	12200103	5	26"	31°	CW	60761501	33°
United Dominion	490022000	4	16"	24°	CW	60719301	23°
United Dominion	7DE41VQ	4	24"	26°	CCW	60559801	27°
United Dominion	7DE41AGQ	3	24"	28°	CCW	60557801	27°
United Dominion	490011001	3	12"	25°	CW	60716301	23°
United Dominion	7DE41VG	3	14"	25°	CW	60716501	23°
United Dominion	7DE41ACL	3	14"	26°	CW	60716701	27°
United Dominion	1210-0098-000	3	16"	25°	CCW	60717201	23°
United Dominion	490011001	3	12"	25°	CW	60716301	23°
Venmar CES	204120002	4	26"	30°	CW	60760901	27°
Vilter Manufacturing	P24430L	4	24"	30°	CW	60559701	27°
Vilter Manufacturing	P18525	5	18"	25°	CW	60560501	27°
Vilter Manufacturing	P18532	5	18"	32°	CW	60560701	33°
Vilter Manufacturing	P24430L	4	24"	30°	CW	60559701	27°
Witt Corp.	12755	4	10"	33°	CW	60759901	33°
Witt Corp.	08221020	4	16"	22°	CW	60719301	23°
Witt Corp.	08221022	4	18"	34°	CW	60558501	33°
Witt Corp.	08221023	4	22"	28°	CW	60559301	27°
Witt Corp.	08221047	4	26"	29°	CW	60760901	27°
Witt Corp.	08221076	4	18"	34°	CW	60558501	33°
Witt Corp.	08221150	5	26"	32°	CW	60761501	33°
Witt Corp.	215112000	3	12"	23°	CW	60716301	23°
Witt Corp.	08221156	3	14"	26°	CW	60716701	27°
Witt Corp.	214100001	4	14"	32°	CW	60760301	33°
Witt Corp.	213456-000	3	20"	25°	CW	60556701	27°
Witt Corp.	213456000	3	20"	25°	CW	60556701	27°
Witt Corp.	213266000	3	24"	28°	CCW	60557801	27°
York	13337	4	20"	34°	CW	60559101	33°
York	13327	3	18"	30°	CW	60556301	30°
York	13339	3	20"	26°	CW	60556701	27°
York	02632169000	4	24"	30°	CW	60559701	27°
York	026-32169-000	4	24"	30°	CW	60559701	27°
York	02631441000	4	24"	32°	CW	60559901	33°

While Lau makes every effort to provide accurate and complete information, the recommended propeller replacement is the closest match to Lau stock products. It is up to the individual purchaser to double-check performance to guarantee the correct propeller application. Lau reserves the right to make changes to this catalog, at any time and without notice, to prices, specifications and models and is not responsible for typographical or image errors.

OEM Name	OEM Part Number	Blade Count	Dia.	Pitch	Rot.	Lau Part Number	Lau Pitch
York	02634758000	3	24"	27°	CW	60557701	27°
York	02634757000	3	24"	29°	CW	60557701	27°
York	026-35492-000	4	24"	30°	CW	60559701	27°
York	026-35536-000	4	20"	34°	CW	60559101	33°
York	7836-324	4	18"	35°	CCW	60558601	33°
York	026-34754-000	3	18"	24°	CW	60556101	27°
York	026-34092-000	3	18"	31°	CW	60556301	30°
York	026-37301-000	3	20"	26°	CW	60556701	27°
York	026-34593-000	3	22"	30°	CW	60557301	27°
York	026-34094-000	3	22"	36°	CW	60557501	33°
York	026-31361-000	3	24"	25°	CW	60557701	27°
York	026-35437-000	3	24"	26°	CW	60557701	27°
York	17743	4	24"	30°	CW	60559701	27°
York	17699	3	18"	24°	CW	60556101	27°
York	67195	3	22"	28°	CW	60557301	27°
York	67196	3	22"	29°	CW	60557301	27°
York	17698	3	22"	30°	CW	60557301	27°
York	17688	3	22"	36°	CW	60557501	33°
York	1452	3	24"	25°	CW	60557701	27°
York	9051	3	24"	26°	CW	60557701	27°
York	170181	3	24"	28°	CW	60557701	27°
York	165520	3	24"	30°	CW	60557901	33°
York	128812	3	24"	30°	CW	60557901	33°
York	0008058	5	18"	27°	CW	60560501	27°
York	0007702	5	18"	25°	CW	60560501	27°
York	0008059	5	18"	31°	CW	60560701	33°
York	8111	3	24"	30°	CW	60557901	33°
York	026V00074001	4	24"	30°	CW	60559701	27°
York	026V00116000	4	24"	22°	CW	60804301	23°
York	026V00073000	3	22"	26°	CW	60557301	27°
York	2600074000	4	24"	30°	CW	60559701	27°
York	2600073000	3	22"	26°	CW	60557301	27°
York		3	22"	26°	CW	60557301	27°
York	013009	4	22"	22°	CCW	60804201	23°
York	026-12696-000	4	24"	20°	CW	60804301	23°
York	026-23874-000	4	20"	28°	CW	60558701	27°

While Lau makes every effort to provide accurate and complete information, the recommended propeller replacement is the closest match to Lau stock products. It is up to the individual purchaser to double-check performance to guarantee the correct propeller application. Lau reserves the right to make changes to this catalog, at any time and without notice, to prices, specifications and models and is not responsible for typographical or image errors.

APPENDIX D



OEM Cross Reference

OEM Name	OEM Part Number	Blade Count	Dia.	Pitch	Rot.	Lau Part Number	Lau Pitch
York	026-24077-000	4	18"	20°	CCW	60800301	23°
York	026-24078-000	4	20"	21°	CCW	60800501	23°
York	026-24079-700	4	22"	24°	CCW	60804201	23°
York	026-24080-000	4	24"	20°	CCW	60804401	23°
York	026-25558-000	4	24"	32°	CW	60559901	33°
York	026-28042-000	4	20"	24°	CW	60800401	23°
York	026-28677-700	4	22"	30°	CW	60559301	27°
York	026-29093-700	4	24"	22°	CW	60804301	23°
York	026-30905-000	4	22"	24°	CW	60804101	23°
York	026-31051-000	4	22"	21°	CW	60804101	23°
York	026-31441-000	4	24"	32°	CW	60559901	33°
York	026-31494-000	4	18"	34°	CW	60558501	33°
York	026-33228-000	4	24"	34°	CW	60559901	33°
York	026-38027-000	4	24"	36°	CW	60559901	33°
York	026-21912-000	5	20"	28°	CW	60560901	27°
York	013187	5	20"	27°	CW	60560901	27°
York	026-14271-000	5	20"	33°	CW	60561101	33°
York	026-23794-000	5	18"	30°	CCW	60561201	33°
York	026-30483-000	5	22"	30°	CW	60561301	27°
York	026-23771-000	3	18"	32°	CW	60556501	33°
York	026-23775-000	3	20"	26°	CW	60556701	27°
York	026-28078-000	3	20"	28°	CW	60556701	27°
York	026-21913-000	3	20"	33°	CW	60557101	33°
York	026-29322-000	3	20"	34°	CW	60557101	33°
York	026-32175-000	3	22"	24°	CW	60557301	27°
York	026-33998-000	3	22"	28°	CW	60557301	27°
York	026-34093-000	3	22"	32°	CW	60557501	33°
York	026-31365-000	3	22"	32°	CW	60557501	33°
York	026-32173-000	3	22"	34°	CW	60557501	33°
York	026-23293-000	3	22"	35°	CW	60557501	33°
York	026-32174-000	3	22"	36°	CW	60557501	33°
York	026-22881-000	3	24"	24°	CW	60557701	27°
York	026-38656-000	3	24"	25°	CW	60557701	27°
York	026-25511-000	3	24"	25°	CW	60557701	27°
York	026-35581-000	3	24"	25°	CW	60557701	27°
York	026-20361-001	3	24"	26°	CW	60557701	27°

While Lau makes every effort to provide accurate and complete information, the recommended propeller replacement is the closest match to Lau stock products. It is up to the individual purchaser to double-check performance to guarantee the correct propeller application. Lau reserves the right to make changes to this catalog, at any time and without notice, to prices, specifications and models and is not responsible for typographical or image errors.

OEM Name	OEM Part Number	Blade Count	Dia.	Pitch	Rot.	Lau Part Number	Lau Pitch
York	026-38482-000	3	24"	26°	CW	60557701	27°
York	02635437000	3	24"	26°	CW	60557701	27°
York	026-035437-000	3	24"	26°	CW	60557701	27°
York	026-34758-000	3	24"	27°	CW	60557701	27°
York	026-25544-000	3	24"	28°	CW	60557701	27°
York	026-34757-000	3	24"	29°	CW	60557701	27°
York	026-25369-000	3	24"	24°	CCW	60557801	27°
York	026-38453-000	3	24"	30°	CW	60557901	33°
York	013158	3	24"	30°	CW	60557901	33°
York	026-35587-000	3	24"	31°	CW	60557901	33°
York	026-35586-000	3	24"	32°	CW	60557901	33°
York	026-35443-000	3	24"	32°	CW	60557901	33°
York	026-35504-000	3	24"	34°	CW	60557901	33°
York	8859	4	24"	32°	CW	60559901	33°
York	9123	4	24"	36°	CW	60559901	33°
York	65037	4	24"	30°	CW	60559701	27°
York	026-24042-000	4	19.8"	28°	CCW	60558801	27°
York	026-28078-000	3	20"	28°	CW	60556701	27°
York	026-39501-000	3	22"	28°	CW	60557301	27°
York	8979	3	22"	28°	CW	60557301	27°
York	8989	3	22"	32°	CW	60557501	33°
York	306	3	24"	25°	CW	60557701	27°
York	9084	3	24"	25°	CW	60557701	27°
York	026-20361-000	3	24"	26°	CW	60557701	27°
York	9144	3	24"	26°	CW	60557701	27°
York	9048	3	24"	27°	CW	60557701	27°
York	9047	3	24"	29°	CW	60557701	27°
York	9143	3	24"	30°	CW	60557901	33°
York	2642195000	3	24"	30°	CW	60557901	33°
York	9086	3	24"	31°	CW	60557901	33°
York	9054	3	24"	32°	CW	60557901	33°
York	9066	3	24"	34°	CW	60557901	33°
Zeks Compressed Air Solutions	6-97186	4	10"	32°	CW	60759901	33°
Zeks Compressed Air Solutions	683588	3	22"	30°	CW	60557301	27°
Zimmerman Manufacturing	0152401	5	24"	27°	CW	60561701	27°

While Lau makes every effort to provide accurate and complete information, the recommended propeller replacement is the closest match to Lau stock products. It is up to the individual purchaser to double-check performance to guarantee the correct propeller application. Lau reserves the right to make changes to this catalog, at any time and without notice, to prices, specifications and models and is not responsible for typographical or image errors.

APPENDIX D



OEM Cross Reference

OEM Name	OEM Part Number	Blade Count	Dia.	Pitch	Rot.	Lau Part Number	Lau Pitch
----------	-----------------	-------------	------	-------	------	-----------------	-----------

While Lau makes every effort to provide accurate and complete information, the recommended propeller replacement is the closest match to Lau stock products. It is up to the individual purchaser to double-check performance to guarantee the correct propeller application. Lau reserves the right to make changes to this catalog, at any time and without notice, to prices, specifications and models and is not responsible for typographical or image errors.

Lau Part Number	Model & Description			Page
00690201	Motor Bracket - A12-9	Belt Drive	Max. ¾ HP	55
00690202	Motor Bracket - A12-12	Belt Drive	Max. ¾ HP	55
00690204	Motor Bracket - A9-7	Belt Drive	Max. ¾ HP	55
00690205	Motor Bracket - A9-6	Belt Drive	Max. ¾ HP	55
00690206	Motor Bracket - A10-8	Belt Drive	Max. ¾ HP	55
00690207	Motor Bracket - A10-10	Belt Drive	Max. ¾ HP	55
00690219	Motor Bracket - A9-9	Belt Drive	Max. ¾ HP	55
00827616	Wheel, A15-15A x 1"			49, 53
00827672	Wheel, A15-15A x 1 ⁷ / ₁₆ "			49
00836010	Wheel, A10-10A x 5/8"			48
00836012	Wheel, A10-10A x ¾"			48, 53
00836016	Wheel, A10-10A x 1"			48
00836112	Wheel, A10-8A x ¾"			48, 53
00836212	Wheel, A10-9A x ¾"			48
00836312	Wheel, A10-7A x ¾"			48
00836412	Wheel, A10-6A x ¾"			48
00840301	Wheel, A12-12A x ¾"			48
00840310	Wheel, A12-12A x 5/8"			48
00840316	Wheel, A12-12A x 1"			48, 53
00840379	Wheel, A12-12A x 1 ⁷ / ₁₆ "			48
00840393	Wheel, A12-12A x 1 ³ / ₁₆ "			48
00841816	Wheel, A15-11A x 1"			49, 53
00841877	Wheel, A15-11A x 1 ³ / ₁₆ "			49
00841880	Wheel, A15-11A x 1 ⁷ / ₁₆ "			49
00850716	Wheel, A12-9A x 1"			48, 53
00850723	Wheel, A12-9A x 1 ⁷ / ₁₆ "			48
00850758	Wheel, A12-9A x 1 ³ / ₁₆ "			48
00851912	Wheel, A9-9A x ¾"			48, 53
00851916	Wheel, A9-9A x 1"			48
00862112	Wheel, A9-7A x ¾"			48, 53
00865816	Wheel, A18-18A x 1"			49, 54
00865874	Wheel, A18-18A x 1 ³ / ₁₆ "			49
00865887	Wheel, A18-18A x 1 ⁷ / ₁₆ "			49
00865916	Wheel, A18-13A x 1"			49, 54
00865960	Wheel, A18-13A x 1 ⁷ / ₁₆ "			49
00866612	Wheel, A9-6A x ¾"			48

Specifications are subject to change without notice or obligation

Lau Part Number	Model & Description			Page
00874616	Wheel, A15-12A x 1"			49
00874716	Wheel, A12-15A x 1"			48
00896004	Bearing Bracket - 18" Blower			55
00897116	Wheel, A12-6A x 1"			48
00920502	Motor Bracket, A 18-18	Belt Drive, Max. ¾ HP		55
00920504	Motor Bracket, A 18-13	Belt Drive, Max. ¾ HP		55
00954816	Wheel, A15-9A x 1"			48
00954823	Wheel, A15-9A x 1 ⁷ / ₁₆ "			49
00954870	Wheel, A15-9A x 1 ³ / ₁₆ "			48
00986716	Wheel, A12-11A x 1"			48
01223712	Wheel, A10-4A x ¾"			48
01239857	Wheel, SI 10-6A x ¾"	CW		44
01239858	Wheel, SI 10-6A x ¾"	CCW		44
01331602	Wheel, DD 10-10 x ½"	CW	Concave	46, 53
01331606	Wheel, DD 10-10 x ½"	CCW	Concave	46
01331701	Wheel, DD 10-9 x ½"	CW	Concave	46
01331704	Wheel, DD 10-9 x ½"	CCW	Concave	46
01332203	Wheel, DD 10-10 x ½"	CW	Convex	46
01332301	Wheel, DD 10-9 x ½"	CW	Convex	46
01332401	Wheel, DD 10-8 x ½"	CW	Convex	46, 53
01332402	Wheel, DD 10-8 x ½"	CCW	Convex	46
01332501	Wheel, DD 10-7 x ½"	CW	Convex	46
01332601	Wheel, DD 10-6 x ½"	CW	Convex	46
01332602	Wheel, DD 10-6 x ½"	CCW	Convex	46
01332614	Wheel, DD 10-6 x 5/8"	CW	Convex	46
01332701	Wheel, DD 10-4 x ½"	CW	Convex	46
01333201	Wheel, DD 9-9 x ½"	CW	Convex	46, 53
01333203	Wheel, DD 9-9 x ½"	CCW	Concave	46
01333401	Wheel, DD 9-4 x ½"	CW	Convex	46
01333501	Wheel, DD 9-6 x ½"	CW	Convex	46
01333602	Wheel, DD 9-7 x ½"	CW	Convex	46, 53
01333603	Wheel, DD 9-7 x ½"	CCW	Convex	46
01333701	Wheel, DD 9-8 x ½"	CW	Convex	46
01333703	Wheel, DD 9-8 x ½"	CCW	Convex	46
01351110	Wheel, SI 9 ¹⁵ / ₁₆ x 6 x 5/8"	CCW	Convex	43
01369315	Wheel, DD 12-9 x 5/8"	CW	Convex	47

Specifications are subject to change without notice or obligation

Lau Part Number	Model & Description			Page
01369325	Wheel, DD 12-9 x 1/2"	CW	Convex	47
01443102	Bearing Bracket - 15" Blower			55
01452801	Wheel, SI 15-6A x 1"	CW		44
01452803	Wheel, SI 15-6A x 1"	CCW		44
01474708	Wheel, SI 12-6A x 3/4"	CW		44
01474709	Wheel, SI 12-6A x 3/4"	CCW		44
01556504	Wheel, DD 12-12 x 5/8"	CW	Concave	47
01556507	Wheel, DD 12-12 x 1/2"	CW	Concave	47
01573001	Bearing Bracket - 12" Blower			55
01767137	Wheel, A15-15A x 1 3/16"			50
01805102	Blower, FGP 10-6A .75	CW		53
01805103	Blower, FGP 12-6A .75	CW		53
01805202	Blower, FGP 18-13A 1.00	CW		53
01812502	Blower, FGP 15-9A 1.00	CW		53
01873101AC	Housing Support Kit			53
01944703	Motor Bracket, A12-12 Belt Drive, Max. 1 1/2 HP			56
01944713	Motor Bracket, A10-10 Belt Drive, Max. 1 1/2 HP			56
01944716	Motor Bracket, 15-15 Belt Drive, Max. 1 1/2 HP			56
01944735	Motor Bracket, A9-9 Belt Drive, Max. 1 1/2 HP			56
01944737	Motor Bracket, A18-18 Belt Drive, Max. 1 1/2 HP			56
01954002	Wheel, A20-18A x 1.19			50
01954020	Wheel, A20-18A x 2.94			50
01954029	Wheel, A20-18A x 1.69			50
01954041	Wheel, A20-18A x 1.44			50
01987302	BI, FGP 10-6A .75	CCW		53
01987303	BI, FGP 12-6A .75	CCW		53
01987402	BI, FGP 15-9A 1.00	CCW		53
01988502	BI, FGP 18-13A 1.00	CCW		53
01996503	Wheel, SI 22-11K x 1 3/16"	CW		45
01996506	Wheel, SI 22-11K x 1 3/16"	CCW		45
01996604	Wheel, SI 25-12K x 1 3/16"	CCW		45
01996605	Wheel, SI 25-12K x 1 3/16"	CW		45
01997202	BI, FGP22-11K 1.19	CW		53
01997203	BI, FGP25-11K 1.19	CW		53
01997302	BI, FGP22-11K 1.19	CCW		52
01997303	BI, FGP25-12K 1.19	CCW		52

Specifications are subject to change without notice or obligation

Lau Part Number	Model & Description		Page
02020203	Wheel, SI 18-9A x 1"	CW	44
02020204	Wheel, SI 18-9A x 1"	CCW	44
02025401AC	Housing Support Kit		53
02025501AC	Housing Support Kit		53
02043907	Wheel, A20-18A x 3		49
02043920	Wheel, A20-18A x 4		49
02048705	Wheel, SI 8½ x 4 x ½	CW	42
02048706	Wheel, SI 8½ x 3¾ x ½	CCW	42
02048738	Wheel, SI 8½ x 4¼ x ½	CW	42
02048739	Wheel, SI 8½ x 4¼ x ½	CCW	42
02048763	Wheel, SI 8 x 3¾/16 x ½	CW	42
02048764	Wheel, SI 8 x 3¾/16 x ½	CCW	42
02048765	Wheel, SI 8 x 4 x ½	CW	42
02048766	Wheel, SI 8 x 4 x ½	CCW	42
02048767	Wheel, SI 8½ x 3¾/16 x ½	CW	42
02048768	Wheel, SI 8½ x 3¾/16 x ½	CCW	42
02048769	Wheel, SI 8½ x 4 x ½	CW	42
02048770	Wheel, SI 8½ x 4 x ½	CCW	42
02048771	Wheel, SI 8½ x 4¼ x ½	CW	42
02048772	Wheel, SI 8½ x 4¼ x ½	CCW	42
02049115	Wheel, SI 77/16 x 2¼ x ½	CW	42
02049120	Wheel, SI 77/16 x 3½ x ½	CCW	42
02049124	Wheel, SI 77/16 x 2¾ x ½	CW	42
02049125	Wheel, SI 77/16 x 2¾ x ½	CCW	42
02049137	Wheel, SI 77/16 x 3½ x ½	CW	42
02049142	Wheel, SI 77/16 x 2¼ x ½	CCW	42
02049153	Wheel, SI 7³/32 x 3⁵/32 x ½	CW	41
02049154	Wheel, SI 7³/32 x 3⁵/32 x ½	CCW	41
02049155	Wheel, SI 7³/32 x 4 x ½	CW	41
02049156	Wheel, SI 7³/32 x 4 x ½	CCW	42
02049157	Wheel, SI 7½ x 2 x ½	CW	42
02049158	Wheel, SI 7½ x 2 x ½	CCW	42
02049159	Wheel, SI 7½ x 2½ x ½	CW	42
02049160	Wheel, SI 7½ x 2½ x ½	CCW	42
02049161	Wheel, SI 7½ x 2¾ x ½	CW	42
02049162	Wheel, SI 7½ x 2¾ x ½	CCW	42

Specifications are subject to change without notice or obligation

Lau Part Number	Model & Description		Page	
02049163	Wheel, SI 7½ x 3 ⁵ / ₃₂ x ½	CW	42	
02049164	Wheel, SI 7½ x 3 ⁵ / ₃₂ x ½	CCW	42	
02049165	Wheel, SI 7½ x 4 x ½	CW	42	
02049166	Wheel, SI 7½ x 4 x ½	CCW	42	
02055301	Wheel, SI 9 ¹ / ₈ x 3¾ x ½	CW	42	
02055302	Wheel, SI 9 ¹ / ₈ x 4¼ x ½	CW	43	
02055303	Wheel, SI 9 ¹ / ₈ x 3¾ x ½	CCW	43	
02055304	Wheel, SI 9 ¹ / ₈ x 4¼ x ½	CCW	43	
02055338	Wheel, SI 9 x 5 x ½	CW	42	
02055339	Wheel, SI 9 x 5 x ½	CCW	42	
02055340	Wheel, SI 10 x 4 x ½	CW	43	
02055341	Wheel, SI 10 x 4 x ½	CCW	43	
02072401AC	Housing Support Kit		53	
02074001	Wheel, SI 15-9A x 1"	CW	44	
02074004	Wheel, SI 15-9A x 1"	CCW	44	
02107103	Wheel, SI 27½-14K x 1 ⁷ / ₁₆ "	CW	44	
02107104	Wheel, SI 27½-14K x 1 ⁷ / ₁₆ "	CCW	44	
02107203	Wheel, SI 30-15K x 1 ⁷ / ₁₆ "	CW	44	
02107204	Wheel, SI 30-15K x 1 ⁷ / ₁₆ "	CCW	44	
02107301	BI, FGP27.5-14K 1.44	CW	52	
02107302	BI, FGP30-15K 1.44	CW	52	
02107401	BI, FGP27.5-14K 1.44	CCW	52	
02107402	BI, FGP30-15K 1.44	CCW	52	
02467702	Motor Mounting Bracket, A15-11, Belt Drive, Max. ¾ HP		55	
02467703	Motor Mounting Bracket, A15-15, Belt Drive, Max. ¾ HP		55	
02484028M	Blower, DD12-9 Less Motor		38	
02484029M	Blower, DD12-12 Less Motor		38	
02484093	Twin Blower Parts Kit - A9		37	
02484094	Twin Blower Parts Kit - A10		37	
02484095	Twin Blower Parts Kit - A12		37	
02484096	Twin Blower Parts Kit - A15		37	
02612601	Motor Mounting Bracket, Resil. Ring, DD-11,12		55	
02618601	Wheel, SI 18-13A x 1"	CW	44	
02618602	Wheel, SI 18-13A x 1"	CCW	44	
02694003	Wheel, DD 11-6 x ½"	CW	Convex	46
02694005	Wheel, DD 11-7 x ½"	CW	Convex	46

Specifications are subject to change without notice or obligation

Lau Part Number	Model & Description			Page
02694007	Wheel, DD 11-8 x 1/2"	CW	Convex	46
02694008	Wheel, DD 11-8 x 1/2"	CC	Convex	46
02694009	Wheel, DD 11-9 x 1/2"	CW	Convex	47
02694010	Wheel, DD 11-9 x 1/2"	CCW	Convex	47
02694107	Wheel, DD 11-8 x 1/2"	CW	Concave	46
02694111	Wheel, DD 11-10 x 1/2"	CW	Concave	47
02694112	Wheel, DD 11-10 x 1/2"	CCW	Concave	47
02710204	Wheel, DD 10-7 x 1/2"	CCW	Convex	46
02750203	Reducing Bushing			49
02757515	Wheel, A12-9A x 3/4" KW			48
02869101	Motor Bracket for DD, 42 Frame, Wire (10" Blower)			55
02869201	Motor Bracket for DD, 48 Frame, Wire (10" Blower)			55
02895721	Wheel, SI 4 1/4 x 2 1/2" x 3/8"	CW		40
02895722	Wheel, SI 4 1/4 x 2 1/2" x 3/8"	CCW		40
02895725	Wheel, SI 4 3/4 x 2 1/16" x 1/2"	CW		40
02895726	Wheel, SI 4 3/4 x 2 1/16" x 1/2"	CCW		40
02895727	Wheel, SI 4 3/4 x 2 1/2" x 1/2"	CW		40
02895728	Wheel, SI 4 3/4 x 2 1/2" x 1/2"	CCW		40
02895729	Wheel, SI 4 3/4 x 2 15/16" x 1/2"	CW		40
02895730	Wheel, SI 4 3/4 x 2 15/16" x 1/2"	CCW		40
02895731	Wheel, SI 4 3/4 x 3 7/16" x 1/2"	CW		40
02895732	Wheel, SI 4 3/4 x 3 7/16" x 1/2"	CCW		40
02895733	Wheel, SI 5 1/4 x 2 1/16" x 1/2"	CW		40
02895734	Wheel, SI 5 1/4 x 2 1/16" x 1/2"	CCW		40
02895735	Wheel, SI 5 1/4 x 2 1/2" x 1/2"	CW		40
02895736	Wheel, SI 5 1/4 x 2 1/2" x 1/2"	CCW		40
02895737	Wheel, SI 5 1/4 x 2 15/16" x 1/2"	CW		41
02895738	Wheel, SI 5 1/4 x 2 15/16" x 1/2"	CCW		41
02895739	Wheel, SI 5 1/4 x 3 7/16" x 1/2"	CW		41
02895740	Wheel, SI 5 1/4 x 3 7/16" x 1/2"	CCW		41
02895741	Wheel, SI 6 5/16 x 2 1/16" x 1/2"	CW		41
02895742	Wheel, SI 6 5/16 x 2 1/16" x 1/2"	CCW		41
02895743	Wheel, SI 6 5/16 x 2 1/2" x 1/2"	CW		41
02895744	Wheel, SI 6 5/16 x 2 1/2" x 1/2"	CCW		41
02895745	Wheel, SI 6 5/16 x 2 15/16" x 1/2"	CW		41
02895746	Wheel, SI 6 5/16 x 2 15/16" x 1/2"	CCW		41

Specifications are subject to change without notice or obligation

Lau Part Number	Model & Description		Page
02895747	Wheel, SI 6 ⁵ / ₁₆ x 3 ⁷ / ₁₆ " x 1/2"	CW	41
02895748	Wheel, SI 6 ⁵ / ₁₆ x 3 ⁷ / ₁₆ " x 1/2"	CCW	41
02895749	Wheel, SI 6 ⁵ / ₁₆ x 3 ¹³ / ₁₆ " x 1/2"	CW	41
02895750	Wheel, SI 6 ⁵ / ₁₆ x 3 ¹³ / ₁₆ " x 1/2"	CCW	41
02895751	Wheel, SI 6 ⁵ / ₁₆ x 4 ¹ / ₄ " x 1/2"	CW	41
02895752	Wheel, SI 6 ⁵ / ₁₆ x 4 ¹ / ₄ " x 1/2"	CCW	41
02895753	Wheel, SI 5 ³ / ₄ x 2 ¹ / ₁₆ " x 1/2"	CW	41
02895754	Wheel, SI 5 ³ / ₄ x 2 ¹ / ₁₆ " x 1/2"	CCW	41
02895755	Wheel, SI 5 ³ / ₄ x 2 ¹ / ₂ " x 1/2"	CW	41
02895756	Wheel, SI 5 ³ / ₄ x 2 ¹ / ₂ " x 1/2"	CCW	41
02895757	Wheel, SI 5 ³ / ₄ x 2 ¹⁵ / ₁₆ " x 1/2"	CW	41
02895758	Wheel, SI 5 ³ / ₄ x 2 ¹⁵ / ₁₆ " x 1/2"	CCW	41
02895759	Wheel, SI 5 ³ / ₄ x 3 ⁷ / ₁₆ " x 1/2"	CW	41
02895760	Wheel, SI 5 ³ / ₄ x 3 ⁷ / ₁₆ " x 1/2"	CCW	41
02895761	Wheel, SI 5 ³ / ₄ x 3 ¹³ / ₁₆ " x 1/2"	CW	41
02895762	Wheel, SI 5 ³ / ₄ x 3 ¹³ / ₁₆ " x 1/2"	CCW	41
02895766	Wheel, SI 3 ¹³ / ₁₆ x 1 ¹ / ₃₂ x 1/4	CW	40
02895767	Wheel, SI 3 ¹³ / ₁₆ x 1 ¹ / ₃₂ x 1/4	CCW	40
02895768	Wheel, SI 3 ¹³ / ₁₆ x 1 ⁷ / ₈ x 5/16	CW	40
02895769	Wheel, SI 3 ¹³ / ₁₆ x 1 ⁷ / ₈ x 5/16	CCW	40
02895770	Wheel, SI 3 ¹³ / ₁₆ x 2 ¹ / ₂ x 5/16	CW	40
02895771	Wheel, SI 3 ¹³ / ₁₆ x 2 ¹ / ₂ x 5/16	CCW	40
02895772	Wheel, SI 3 ²⁷ / ₃₂ x 1 ¹ / ₄ x 1/4	CW	40
02895773	Wheel, SI 3 ²⁷ / ₃₂ x 1 ¹ / ₄ x 1/4	CCW	40
02895774	Wheel, SI 4 x 1 ¹ / ₂ x 5/16	CCW	40
02895775	Wheel, SI 4 x 2 ¹ / ₂ x 1/4	CCW	40
02895776	Wheel, SI 4 ¹ / ₄ x 2 x 1/4	CCW	40
02895777	Wheel, SI 4 ¹ / ₄ x 2 ¹⁵ / ₁₆ x 1/4	CCW	40
02895778	Wheel, SI 5 ⁵ / ₈ x 1 ⁹ / ₁₆ x 5/16	CCW	41
02895779	Wheel, SI 5 ³ / ₄ x 4 x 1/2	CW	41
02895780	Wheel, SI 5 ³ / ₄ x 4 x 1/2	CCW	41
02895781	Wheel, SI 6 ¹ / ₄ x 4 x 1/2	CW	41
02895782	Wheel, SI 6 ¹ / ₄ x 4 x 1/2	CCW	41
02895801	Wheel, DI 4 ³ / ₄ x 6 ⁷ / ₈ " x 1/2	CW	45
02895802	Wheel, DI 5 ¹ / ₄ x 5 ⁷ / ₈ " x 1/2	CW	45
02895803	Wheel, DI 5 ¹ / ₄ x 6 ⁷ / ₈ " x 1/2	CW	45

Specifications are subject to change without notice or obligation

Lau Part Number	Model & Description	Page
02895804	Wheel, DI 5 ³ / ₄ x 5 ⁷ / ₈ " x 1/2 CW	45
02895805	Wheel, DI 5 ³ / ₄ x 6 ⁷ / ₈ " x 1/2 CW	45
02895806	Wheel, DI 5 ³ / ₄ x 8 ¹ / ₂ " x 1/2 CW	45
02895807	Wheel, DI 6 ⁵ / ₁₆ x 7 ⁵ / ₈ " x 1/2 CW	45
02895808	Wheel, DI 4 ³ / ₄ x 5 ¹ / ₈ " x 1/2 CW	45
02895814	Wheel, DI 4 ³ / ₄ x 5 ¹ / ₈ x 1/2 CCW	45
02895815	Wheel, DI 4 ³ / ₄ x 6 ⁷ / ₈ x 1/2 CCW	45
02895816	Wheel, DI 5 ¹ / ₄ x 5 ⁷ / ₈ x 1/2 CCW	45
02895817	Wheel, DI 5 ¹ / ₄ x 6 ³ / ₄ x 1/2 CCW	45
02895818	Wheel, DI 5 ¹ / ₄ x 6 ³ / ₄ x 1/2 CW	45
02895819	Wheel, DI 5 ¹ / ₄ x 6 ⁷ / ₈ x 1/2 CCW	45
02895820	Wheel, DI 5 ³ / ₄ x 5 ⁷ / ₈ x 1/2 CCW	45
02895821	Wheel, DI 5 ³ / ₄ x 6 ⁷ / ₈ x 1/2 CCW	45
02895822	Wheel, DI 5 ³ / ₄ x 7 ⁵ / ₈ x 1/2 CW	45
02895823	Wheel, DI 5 ³ / ₄ x 7 ⁵ / ₈ x 1/2 CCW	45
02895824	Wheel, DI 5 ³ / ₄ x 8 x 1/2 CW	45
02895825	Wheel, DI 5 ³ / ₄ x 8 x 1/2 CCW	45
02895826	Wheel, DI 5 ³ / ₄ x 8 ¹ / ₂ x 1/2 CCW	45
02895827	Wheel, DI 6 ⁵ / ₁₆ x 6 ³ / ₈ x 3/4 CW	45
02895828	Wheel, DI 6 ⁵ / ₁₆ x 6 ³ / ₈ x 3/4 CCW	45
02895829	Wheel, DI 6 ⁵ / ₁₆ x 7 ⁵ / ₈ x 1/2 CCW	45
02895832	Wheel, DI 7 ¹ / ₂ x 4 x 3/4 CW	45
02895833	Wheel, DI 7 ¹ / ₂ x 4 x 3/4 CCW	45
02895834	Wheel, DI 7 ¹ / ₂ x 5 x 3/4 CW	45
02895835	Wheel, DI 7 ¹ / ₂ x 5 x 3/4 CCW	45
02895836	Wheel, DI 7 ¹ / ₂ x 6 ¹¹ / ₃₂ x 3/4 CW	45
02895837	Wheel, DI 7 ¹ / ₂ x 6 ¹¹ / ₃₂ x 3/4 CCW	45
02917501	Bearing Bracket Kit, 3/4"	55
02917601	Bearing Bracket Kit, 1"	55
02942101	Steel Shaft Adapter Bushing, 5/16" OD x 1/4" ID x 1" Length	43
02942102	Steel Shaft Adapter Bushing, 3/8" OD x 1/4" ID x 1 1/16" Length	43
02942103	Steel Shaft Adapter Bushing, 3/8" OD x 5/16" ID x 1 1/16" Length	43
02942104	Steel Shaft Adapter Bushing, 1/2" OD x 5/16" ID x 1 1/16" Length	43
02942105	Steel Shaft Adapter Bushing, 1/2" OD x 3/8" ID x 1 1/16" Length	43
02942106	Steel Shaft Adapter Bushing, 5/8" OD x 1/2" ID x 1 15/16" Length	43
02942107	Steel Shaft Adapter Bushing, 3/4" OD x 5/8" ID x 1 1/4" Length	43

Specifications are subject to change without notice or obligation

Lau Part Number	Model & Description	Page	
05029602	Wheel, A36-30H x 2.47	51	
05029603	Wheel, A36-36H x 2.47	51	
05029605	Wheel, A36-20H x 2.19	51	
05029606	Wheel, A36-36H x 2.19	51	
05029610	Wheel, A36-36H x 1.94	51	
05029612	Wheel, A36-30H x 1.94	51	
05030605	Wheel, A30-30H x 1.94	51	
05030609	Wheel, A30-30H x 1.69	51	
05030614	Wheel, A30-30H x 2.19	51	
05030803	Wheel, A27-25H x 1.69	51	
05030804	Wheel, A27-27H x 1.69	51	
05030811	Wheel, A27-27H x 2.19	51	
05030817	Wheel, A27-27H x 1.94	51	
05030818	Wheel, A27-25H x 1.94	51	
05031003	Wheel, A25-25H x 1.47	50	
05031006	Wheel, A25-25H x 1.69	50	
05031009H	Wheel, A25-25H	54	
05031012	Wheel, A25-25H x 1.94	50	
05031020	Wheel, A25-25H x 2.19	50	
05031203	Wheel, A22-22H x 1.47	50	
05031206	Wheel, A22-22H x 2.19	50	
05031206H	Wheel, A22-22H	54	
05031208	Wheel, A22-22H x 1.69	50	
05031210	Wheel, A22-22H x 1.94	50	
05031403	Wheel, A20-20H x 1.47	50	
05031406	Wheel, A20-20H x 1.69	50	
05031406H	Wheel, A20-20H	54	
05031407	Wheel, A20-20H x 1.19	50	
05031410	Wheel, A20-20H x 1.94	50	
05031419	Wheel, A20-20H x 2.19	50	
05036406C	Blower, A20-20H x 1.69	BHD PB	54
05036506C	Blower, A22-22H x 2.19	BHD PB	54
05036606C	Blower, A25-25H x 2.47	BHD PB	54
05055002	Allen Head Screw 5/16-24 x 5/8"		32
05099801	Pitch Gauge		19
05214101	Hub Puller (Heavy Duty)		12, 19, 31

Specifications are subject to change without notice or obligation

Lau Part Number	Model & Description	Page
05221101	Replacement Fingers for Hub Pullers (Heavy Duty)	31
05221201	Allen Head Screw ¼-28 x ½"	31
05221301	Replacement Centering Sleeve for Hub Pullers (Heavy Duty)	31
05249701	Replacement Main Center Shaft for Hub Pullers (General Duty)	31
05249801	Replacement Centering Sleeve for Hub Pullers (General Duty)	31
05249901	Replacement Fingers for Hub Pullers (General Duty)	31
05380401	Hub Puller – General Duty	12, 19, 31
05382501	Interchangeable Hub for Hubless Props ¼" Bore	28, 29
05382502	Interchangeable Hub for Hubless Props 5/16" Bore	28, 29
05407401	Motor Bracket for DD, Belly Band, 45 Frame	55
05407402	Motor Bracket for DD, Belly Band, 48 Frame	55
05409101	Motor Bracket for DD, 48 Frame, Wire (12" Blower)	55
05486601	Bearing Bracket, Bolt On for Belt Drive 9"	55
05486701	Bearing Bracket, Bolt On for Belt Drive 10"	55
05486801	Bearing Bracket, Bolt On for Belt Drive 11"	55
05486901	Bearing Bracket, Bolt On for Belt Drive 12"	55
0572680000	Condenser Fan Motor	91
0572690000	Condenser Fan Motor	91
0572700000	Furnace Motor	89
0572710000	Furnace Motor	89
0572720000	Furnace Motor	90
0572730000	Furnace Motor	90
0574300001M	Blower, A9-6 ACE	36
0574300002M	Blower, A9-7 ACE	36
0574300003M	Blower, A9-9 ACE	36
0574310001M	Blower, A10-6 ACE	36
0574310002M	Blower, A10-8 ACE	36
0574310003M	Blower, A10-10 ACE	36
38208002M	Blower, A15-15 ACE	36
382080004M	Blower, A15-11ACE	53
3820800003M	Blower, A15-9 ACE	36
3820800004M	Blower, A15-11 ACE	36
38208201	Flange Bearing (Obsolete)	55
38208601	Bearing, Sleeve, PB, ¾" (Pair)	57
38208701	Bearing, Sleeve, PB, 1" (Pair)	57
38209001	Bearing, Cartridge, MKIII 1" (Pair)	56

Specifications are subject to change without notice or obligation

Lau Part Number	Model & Description	Page
38209101	Bearing, Cartridge, MKIV 3/4" (Pair)	56
38209301	Bearing, Sleeve, PB, Heavy Duty 1" (Pair)	57
38209401	Bearing, Oil, Heavy Duty 1" (Pair)	56
38209501	Shaft, 1" x 25"	53-54, 59
38209601	Shaft, 3/4" x 20"	53, 59
38220301	Thrust Sleeve & Spacer Kit, 3/4" (Kit)	59
38220401	Bearing, Sleeve, PB, 5/8" (Pair)	57
38220501	Shaft, 5/8" x 20"	59
38220601	Thrust Collar Kit, 3/4" (Kit)	59
38220701	Thrust Collar Kit, 1" (Kit)	59
38220901	Vibro-Pads (Bag of 12)	59
38227201	Bearing, Cartridge, MKIII with Journal, 3/4" (Pair)	56
38240401	Bearing, Lau Oil, 5/8" (Pair)	56
38243002M	Blower, A18-18 ACE	36
38243101	Thrust Collar Kit, 5/8" (Kit)	59
3824300003M	Blower, A18-13 ACE	36
3824340021M	Blower, A12-6 ACE	36
3824340022M	Blower, A12-9 ACE	36
38243420M	Blower, A12-12 ACE	36
38244201	Bearing, Lau Oil, 3/4" (Pair)	56
38244202	Bearing, Lau Oil, 1" (Pair)	56
38244301	Bearing, Lau-Pak, 5/8" (Pair)	56
38244302	Bearing, Lau-Pak, 3/4" (Pair)	53
38244303	Bearing, Lau-Pak, 1" (Pair)	53-54
38244901	Bearing, Oil, 1" (Pair)	56
38245001	Bearing, Oil, 3/4" (Pair)	56
38249101	Thrust Spacer Kit, 5/8" (Bag)	59
38249102	Thrust Spacer Kit, 3/4" (Bag)	59
38249103	Thrust Spacer Kit, 1" (Bag)	59
38249201	Shaft, 1" x 38"	54, 59
38251301M	Blower, DD9-7A, Less Motor	38
38251302M	Blower, DD9-9A, Less Motor	38
38251303M	Blower, DD10-8A, Less Motor	38
38251304M	Blower, DD10-10A, Less Motor	38
38251401	Motor Mounting Bracket, Resil. Ring, DD-9	55
38251501	Motor Mounting Bracket, Resil. Ring, DD-10	55

Specifications are subject to change without notice or obligation

Lau Part Number	Model & Description					Page
38252101	Motor Mounting Hardware, for 9"-15" Blowers (Bag)					59
38252301	Motor Adjustment Kit - Tailpiece Assembly					59
38252501	Grommets, Motor Adjustment (Bag of 6)					59
38256201	Bearing, Ball, Sealed, 1 3/16" (Pair)					57
38256501	Bearing, Ball, Flange, 3/4" (Pair)					57
38256502	Bearing, Ball, Flange, 1" (Pair)					57
38256701	Bearing, Ball, PB, 3/4" (Pair)					57
38256801	Bearing, Ball, PB, 1" (Pair)					57
38256901	Bearing, Ball, PB, 1 3/16" (Pair)					57
38257001	Bearing, Ball, PB, 1 7/16" (Pair)					57
38258801	Bearing, Ball, Sealed, 3/4" (Pair)					53, 57
38259001	Bearing, Ball, Sealed, 1" (Pair)					53-54, 57
38269301	Shaft, 3/4" x 38"					59
38269401	Bearing, Sealed, 3/4" (Pair) Brundage					56
38269501	Bearing, Sealed, 1" (Pair) Brundage					56
38269601	Bearing, Oil Type, 3/4" (Pair) Brundage					56
38269701	Bearing, Oil Type, 1" (Pair) Brundage					56
38269901	Bearing Bracket, Knock Down, 1 13/16" OD Brgs					55
60262201	4-Blade	12"	23°	CW	Free-air Style	14
60262301	4-Blade	12"	23°	CCW	Free-air Style	14
60262801	4-Blade	14"	27°	CW	Free-air Style	14
60262901	4-Blade	14"	27°	CCW	Free-air Style	14
60263801	4-Blade	20"	23°	CW	Free-air Style	14
60263901	4-Blade	20"	23°	CCW	Free-air Style	14
60264001	4-Blade	20"	27°	CW	Free-air Style	14
60264101	4-Blade	20"	27°	CCW	Free-air Style	14
60265201	3-Blade	10"	27°	CW	Free-air Style	9
60265301	3-Blade	10"	27°	CCW	Free-air Style	9
60265401	3-Blade	12"	23°	CW	Free-air Style	9
60265501	3-Blade	12"	23°	CCW	Free-air Style	9
60265801	3-Blade	14"	23°	CW	Free-air Style	9
60265901	3-Blade	14"	23°	CCW	Free-air Style	9
60266201	3-Blade	16"	23°	CW	Free-air Style	9
60266301	3-Blade	16"	23°	CCW	Free-air Style	9
60267001	3-Blade	20"	23°	CW	Free-air Style	9
60267101	3-Blade	20"	23°	CCW	Free-air Style	9

Specifications are subject to change without notice or obligation

Lau Part Number	Model & Description						Page
60267601	3-Blade	24"	18°	CW	Free-air Style		9
60269301	4-Blade	10"	23°	CW	Free-air Style		14
60269401	4-Blade	10"	23°	CCW	Free-air Style		14
60285301	4-Blade	20"	33°	CW	Free-air Style		14
60285401	4-Blade	20"	33°	CCW	Free-air Style		14
60331501	Bushing Hub	1 1/8"		H-Style			13, 23
60331502	Bushing Hub	1 3/16"		H-Style			13, 23
60331503	Bushing Hub	1 3/8"		H-Style			13, 23
60331504	Bushing Hub	1/2"		H-Style			13, 23
60331505	Bushing Hub	5/8"		H-Style			13, 23
60331506	Bushing Hub	3/4"		H-Style			13, 23
60331507	Bushing Hub	7/8"		H-Style			13, 23
60331508	Bushing Hub	1"		H-Style			13, 23
60331509	Bushing Hub	1 1/4"		H-Style			13, 23
60379501	Rainshield	7" x 1/2"					31
60379502	Rainshield	3 1/2" x 5/8"					31
60385303	Rainshield	3 1/2" x 1/2"					31
60555301	4-Blade	18"	23°	CW	Free-air Style		14
60555401	4-Blade	18"	23°	CCW	Free-air Style		14
60555501	4-Blade	18"	27°	CW	Free-air Style		14
60555601	4-Blade	18"	27°	CCW	Free-air Style		14
60555901	3-Blade	18"	23°	CW	Interchangeable		9
60556001	3-Blade	18"	23°	CCW	Interchangeable		9, 11
60556101	3-Blade	18"	27°	CW	Interchangeable		11
60556201	3-Blade	18"	27°	CCW	Interchangeable		11
60556301	3-Blade	18"	30°	CW	Interchangeable		11
60556401	3-Blade	18"	30°	CCW	Interchangeable		11
60556501	3-Blade	18"	33°	CW	Interchangeable		11
60556601	3-Blade	18"	33°	CCW	Interchangeable		11
60556701	3-Blade	20"	27°	CW	Interchangeable		11
60556901	3-Blade	20"	30°	CW	Interchangeable		11
60557001	3-Blade	20"	30°	CCW	Interchangeable		11
60557101	3-Blade	20"	33°	CW	Interchangeable		11
60557201	3-Blade	20"	33°	CCW	Interchangeable		11
60557301	3-Blade	22"	27°	CW	Interchangeable		11
60557401	3-Blade	22"	27°	CCW	Interchangeable		11

Specifications are subject to change without notice or obligation

Lau Part Number	Model & Description						Page
60557501	3-Blade	22"	33°		CW	Interchangeable	11
60557601	3-Blade	22"	33°		CCW	Interchangeable	11
60557701	3-Blade	24"	27°		CW	Interchangeable	11, 33
60557801	3-Blade	24"	27°		C CW	Interchangeable	12
60557901	3-Blade	24"	33°		CW	Interchangeable	12
60558001	3-Blade	24"	33°		CCW	Interchangeable	12
60558101	4-Blade	18"	27°		CW	Interchangeable	17
60558201	4-Blade	18"	27°		CCW	Interchangeable	17
60558301	4-Blade	18"	30°		CW	Interchangeable	17
60558401	4-Blade	18"	30°		CCW	Interchangeable	17
60558501	4-Blade	18"	33°		CW	Interchangeable	17
60558601	4-Blade	18"	33°		CCW	Interchangeable	17
60558701	4-Blade	20"	27°		CW	Interchangeable	17
60558801	4-Blade	20"	27°		CCW	Interchangeable	17
60558901	4-Blade	20"	30°		CW	Interchangeable	17
60559001	4-Blade	20"	30°		CCW	Interchangeable	17
60559101	4-Blade	20"	33°		CW	Interchangeable	17
60559201	4-Blade	20"	33°		CCW	Interchangeable	17
60559301	4-Blade	22"	27°		CW	Interchangeable	18
60559401	4-Blade	22"	27°		CCW	Interchangeable	18
60559501	4-Blade	22"	33°		CW	Interchangeable	18
60559601	4-Blade	22"	33°		CCW	Interchangeable	18
60559701	4-Blade	24"	27°		CW	Interchangeable	18, 33
60559801	4-Blade	24"	27°		CCW	Interchangeable	18
60559901	4-Blade	24"	33°		CW	Interchangeable	18
60560001	4-Blade	24"	33°		CCW	Interchangeable	18
60560101	5-Blade	16"	27°		CW	Interchangeable	21
60560201	5-Blade	16"	27°		CCW	Interchangeable	21
60560301	5-Blade	16"	33°		CW	Interchangeable	21
60560401	5-Blade	16"	33°		CCW	Interchangeable	21
60560501	5-Blade	18"	27°		CW	Interchangeable	21
60560601	5-Blade	18"	27°		CCW	Interchangeable	21
60560701	5-Blade	18"	33°		CW	Interchangeable	21
60560801	5-Blade	18"	33°		CCW	Interchangeable	21
60560901	5-Blade	20"	27°		CW	Interchangeable	22
60561001	5-Blade	20"	27°		CCW	Interchangeable	22

Specifications are subject to change without notice or obligation

Lau Part Number	Model & Description						Page
60561101	5-Blade	20"	33°		CW	Interchangeable	22
60561201	5-Blade	20"	33°		CCW	Interchangeable	22
60561301	5-Blade	22"	27°		CW	Interchangeable	22
60561401	5-Blade	22"	27°		CCW	Interchangeable	22
60561501	5-Blade	22"	33°		CW	Interchangeable	22
60561601	5-Blade	22"	33°		CCW	Interchangeable	22
60561701	5-Blade	24"	27°		CW	Interchangeable	22
60561801	5-Blade	24"	27°		CCW	Interchangeable	22
60561901	5-Blade	24"	33°		CW	Interchangeable	22
60562001	5-Blade	24"	33°		CCW	Interchangeable	22
60562101	4-Blade	24"	18°		CW	Free-air Style	14
60562201	4-Blade	24"	18°		CCW	Free-air Style	14
60562301	4-Blade	24"	23°		CW	Free-air Style	14
60562401	4-Blade	24"	23°		CCW	Free-air Style	14
60562501	4-Blade	24"	27°		CW	Free-air Style	14
60562601	4-Blade	24"	27°		CCW	Free-air Style	14
60565301	3-Blade	30"	22°		CW		13
60565401	3-Blade	30"	27°		CW		13
60565501	3-Blade	36"	27°		CW		13
60565601	3-Blade	36"	33°		CW		13
60652101	2-Blade	18"	32°		CCW	Intake	8
60716101	3-Blade	12"	19°		CW	Interchangeable	10
60716201	3-Blade	12"	19°		CCW	Interchangeable	10
60716301	3-Blade	12"	23°		CW	Interchangeable	10
60716401	3-Blade	12"	23°		CCW	Interchangeable	10
60716501	3-Blade	14"	23°		CW	Interchangeable	10
60716601	3-Blade	14"	23°		CCW	Interchangeable	10
60716701	3-Blade	14"	27°		CW	Interchangeable	10
60716801	3-Blade	14"	27°		CCW	Interchangeable	10
60716901	3-Blade	16"	19°		CW	Interchangeable	10
60717001	3-Blade	16"	19°		CCW	Interchangeable	10
60717101	3-Blade	16"	23°		CW	Interchangeable	10
60717201	3-Blade	16"	23°		CCW	Interchangeable	10
60717301	4-Blade	10"	19°		CW	Interchangeable	16
60717401	4-Blade	10"	19°		CCW	Interchangeable	16
60717501	4-Blade	10"	23°		CW	Interchangeable	16

Specifications are subject to change without notice or obligation

Lau Part Number	Model & Description						Page
60717601	4-Blade	10"	23°		CCW	Interchangeable	16
60717701	4-Blade	10"	27°		CW	Interchangeable	16
60717801	4-Blade	10"	27°		CCW	Interchangeable	16
60717901	4-Blade	12"	19°		CW	Interchangeable	16
60718001	4-Blade	12"	19°		CCW	Interchangeable	16
60718101	4-Blade	12"	23°		CW	Interchangeable	16
60718201	4-Blade	12"	23°		CCW	Interchangeable	16
60718301	4-Blade	12"	27°		CW	Interchangeable	16
60718401	4-Blade	12"	27°		CCW	Interchangeable	16
60718501	4-Blade	14"	19°		CW	Interchangeable	16
60718601	4-Blade	14"	19°		CCW	Interchangeable	16
60718701	4-Blade	14"	23°		CW	Interchangeable	16
60718801	4-Blade	14"	23°		CCW	Interchangeable	16
60718901	4-Blade	14"	27°		CW	Interchangeable	16
60719001	4-Blade	14"	27°		CCW	Interchangeable	16
60719101	4-Blade	16"	19°		CW	Interchangeable	16
60719201	4-Blade	16"	19°		CCW	Interchangeable	16
60719301	4-Blade	16"	23°		CW	Interchangeable	16
60719401	4-Blade	16"	23°		CCW	Interchangeable	17
60719501	4-Blade	16"	27°		CW	Interchangeable	17
60719601	4-Blade	16"	27°		CCW	Interchangeable	17
60720101	5-Blade	10"	27°		CW	Interchangeable	21
60720201	5-Blade	10"	27°		CCW	Interchangeable	21
60720401	5-Blade	12"	19°		CCW	Interchangeable	21
60720501	5-Blade	12"	23°		CW	Interchangeable	21
60720601	5-Blade	12"	23°		CCW	Interchangeable	21
60720701	5-Blade	12"	27°		CW	Interchangeable	21
60720801	5-Blade	12"	27°		CCW	Interchangeable	21
60721101	5-Blade	14"	23°		CW	Interchangeable	21
60721201	5-Blade	14"	24°		CCW	Interchangeable	21
60721301	5-Blade	14"	27°		CW	Interchangeable	21
60721401	5-Blade	14"	27°		CCW	Interchangeable	21
60743401	2-Blade	14"	36°		CW	Discharge	8
60759901	4-Blade	10"	33°		CW	Interchangeable	16
60760001	4-Blade	10"	33°		CCW	Interchangeable	16
60760101	4-Blade	12"	33°		CW	Interchangeable	16

Specifications are subject to change without notice or obligation

Lau Part Number	Model & Description						Page
60760201	4-Blade	12"	33°	CCW	Interchangeable		16
60760301	4-Blade	14"	33°	CW	Interchangeable		16
60760401	4-Blade	14"	33°	CCW	Interchangeable		16
60760501	4-Blade	16"	33°	CW	Interchangeable		17
60760601	4-Blade	16"	33°	CCW	Interchangeable		17
60760701	4-Blade	26"	24°	CW	Interchangeable		18
60760801	4-Blade	26"	24°	CCW	Interchangeable		18
60760901	4-Blade	26"	27°	CW	Interchangeable		18
60761001	4-Blade	26"	27°	CCW	Interchangeable		18
60761101	4-Blade	26"	33°	CW	Interchangeable		19
60761201	4-Blade	26"	33°	CCW	Interchangeable		19
60761301	5-Blade	26"	27°	CW	Interchangeable		22
60761401	5-Blade	26"	27°	CCW	Interchangeable		22
60761501	5-Blade	26"	33°	CW	Interchangeable		22
60761601	5-Blade	26"	33°	CCW	Interchangeable		22
60765801	Interchangeable Hub ¼" Bore			CCW	Intake		9, 15
60765802	Interchangeable Hub ⅝" Bore			CCW	Intake		9, 15
60765803	Interchangeable Hub ⅜" Bore			CCW	Intake		9, 15
60765804	Interchangeable Hub ½" Bore			CCW	Intake		9, 15
60765805	Interchangeable Hub ⅝" Bore			CCW	Intake		9, 15
60765806	Interchangeable Hub ¾" Bore			CW	Interchangeable		9, 15
60772501	2-Blade	18"	28°	CCW	Interchangeable		8
60772601	2-Blade	20"	28°	CW	Interchangeable		8
60772701	2-Blade	22"	16°	CCW	Intake		8
60772801	2-Blade	24"	27°	CCW	Intake		8
60800201	4-Blade	18"	23°	CW	Interchangeable		17
60800301	4-Blade	18"	23°	CCW	Interchangeable		17
60800401	4-Blade	20"	23°	CW	Interchangeable		17
60800501	4-Blade	20"	23°	CCW	Interchangeable		17
60804101	4-Blade	22"	23°	CW	Interchangeable		18
60804201	4-Blade	22"	23°	CCW	Interchangeable		18
60804301	4-Blade	24"	23°	CW	Interchangeable		18
60804401	4-Blade	24"	23°	CCW	Interchangeable		18
60814201	2-Blade	22"	27°	CCW	Intake		8
60832901	4-Blade	24"	27°	CW	Interchangeable		20
60833001	4-Blade	26"	27°	CW	Interchangeable		20

Specifications are subject to change without notice or obligation

Lau Part Number	Model & Description						Page
60833101	4-Blade	28"	27°		CW	Interchangeable	20
60833201	4-Blade	30"	27°		CW	Interchangeable	20
60833301	4-Blade	36"	27°		CW	Interchangeable	20
60833401	4-Blade	42"	27°		CW	Interchangeable	20
60833501	4-Blade	48"	27°		CW	Interchangeable	20
60833601	4-Blade	54"	27°		CW	Interchangeable	20
60833701	4-Blade	60"	27°		CW	Interchangeable	20
60833801	6-Blade	30"	40°		CW	Interchangeable	23
60833901	6-Blade	36"	40°		CW	Interchangeable	23
60834001	6-Blade	42"	40°		CW	Interchangeable	23
60834101	6-Blade	48"	40°		CW	Interchangeable	23
60834201	6-Blade	54"	40°		CW	Interchangeable	23
60834301	4-Blade	60"	40°		CW	Interchangeable	20
60834801	5-Blade	7"	27°		CW	Interchangeable	28
60834901	5-Blade	7"	27°		CCW	Interchangeable	28
60835001	5-Blade	7"	27°		CW	Interchangeable	28
60835101	5-Blade	7"	27°		CCW	Interchangeable	28
60835201	5-Blade	8"	24°		CW	Interchangeable	28
60835301	5-Blade	8"	24°		CCW	Interchangeable	28
60835401	5-Blade	8"	30°		CW	Interchangeable	28
60835501	5-Blade	8"	30°		CCW	Interchangeable	28
60835601	5-Blade	8"	18°		CW	Interchangeable	28
60835701	5-Blade	8"	18°		CCW	Interchangeable	28
60835801	5-Blade	8"	18°		CW	Interchangeable	28
60835901	5-Blade	8"	18°		CCW	Interchangeable	28
60836201	5-Blade	9"	26°		CW	Interchangeable	28
60836301	5-Blade	9"	26°		CCW	Interchangeable	28
60836601	5-Blade	10"	31°		CW	Interchangeable	28
60836701	5-Blade	10"	31°		CCW	Interchangeable	28
60836801	5-Blade	10"	20°		CW	Interchangeable	28
60836901	5-Blade	10"	20°		CCW	Interchangeable	28
60837001	5-Blade	10"	31°		CW	Interchangeable	28
60837101	5-Blade	10"	31°		CCW	Interchangeable	28
60837201	5-Blade	7"	20°		CW	Interchangeable	29
60837301	5-Blade	7"	31°		CW	Interchangeable	29
60837401	5-Blade	7¾"	20°		CW	Interchangeable	29

Specifications are subject to change without notice or obligation

Lau Part Number	Model & Description						Page
60837501	5-Blade	7¾"	31°	CW	Interchangeable		29
60837601	5-Blade	8"	24°	CW	Interchangeable		29
60837701	5-Blade	8"	31°	CW	Interchangeable		29
60837801	5-Blade	9"	20°	CW	Interchangeable		29
60837901	5-Blade	9"	31°	CW	Interchangeable		29
60838001	5-Blade	10"	20°	CW	Interchangeable		29
60838301	3-Blade	8¾"	32°	CW	Interchangeable		29
60841201	4-Blade	22"	30°	CW	Discharge		18
60841501	4-Blade	24"	25°	CW	Intake		18
60841701	4-Blade	24"	23°	CCW	Intake		18
60870301	3-Blade	20"	21°	CW	Discharge		11
60885701	4-Blade	29"	28°	CW	Discharge		18
60943601	4-Blade	20"	29°	CW	Discharge		17
60943701	4-Blade	30"	25°	CW	Discharge		19
60997201	4-Blade	29"	32°	CW	Discharge		19
60998901	3-Blade	14"	19°	CW	Intake		10
60999001	3-Blade	20"	25°	CCW	Intake		11
61017601	4-Blade	31"	25°	CW	Discharge		19
61040201	2-Blade	24"	22°	CCW	Intake		8
61046601	3-Blade	29"	26°	CW	Discharge		12
61093601	3-Blade	30"	22°	CW	Interchangeable		13
61093701	3-Blade	30"	27°	CW	Interchangeable		13
61093801	3-Blade	36"	27°	CW	Interchangeable		13
61093901	3-Blade	36"	33°	CW	Interchangeable		13
6126890010	6-Blade XHD	30"	40°	CW	Interchangeable		23
6126890011	6-Blade XHD	36"	40°	CW	Interchangeable		23
6126890012	6-Blade XHD	42"	40°	CW	Interchangeable		23
6126890013	6-Blade XHD	48"	40°	CW	Interchangeable		23
6126890014	6-Blade XHD	54"	40°	CW	Interchangeable		23
72513808	Bushing Hub	1"		P-Style			13, 23, 30
72513809	Bushing Hub	1 1/8"		P-Style			13, 23, 30
72513810	Bushing Hub	1 1/4"		P-Style			13, 23, 30
72513811	Bushing Hub	1 3/8"		P-Style			13, 23, 30
72513812	Bushing Hub	1 3/16"		P-Style			13, 23, 30
72513813	Bushing Hub	1 5/8"		P-Style			13, 23, 30
72513815	Bushing Hub	1 7/16"		P-Style			13, 23, 30

Specifications are subject to change without notice or obligation

Lau Part Number	Model & Description					Page
0572670000	Condenser Fan Motor					91
6126890001	4-Blade XHD	24"	27°	CW	Interchangeable	20
6126890002	4-Blade XHD	29"	27°	CW	Interchangeable	20
6126890003	4-Blade XHD	31"	27°	CW	Interchangeable	20
6126890004	4-Blade XHD	30"	27°	CW	Interchangeable	20
6126890005	4-Blade XHD	36"	27°	CW	Interchangeable	20
6126890006	4-Blade XHD	42"	27°	CW	Interchangeable	20
6126890007	4-Blade XHD	48"	27°	CW	Interchangeable	20
6126890008	4-Blade XHD	54"	27°	CW	Interchangeable	20
6126890009	4-Blade XHD	60"	27°	CW	Interchangeable	20
6127290001	4-Blade	30"	30°	CW	Discharge	19
6127600001	4-Blade	30"	27°	CW	Discharge	19
6128120001	3-Blade OEM	24"	20°	CW	Intake	27
6128130001	3-Blade OEM	24"	23°	CW	Intake	27
6128140001	3-Blade OEM	18"	18°	CW	Intake	27
6128150001	3-Blade OEM	18"	28°	CW	Intake	27
6128170001	3-Blade OEM	24"	22°	CW	Intake	27
6128180001	2-Blade OEM	24"	28°	CW	Intake	27
6128190001	2-Blade OEM	22"	28°	CW	Intake	27
6128200001	3-Blade OEM	18"	30°	CW	Intake	27
6128210001	2-Blade OEM	22"	20°	CW	Intake	27
6128220001	3-Blade OEM	22"	30°	CW	Intake	27
6128230001	3-Blade OEM	24"	30°	CW	Intake	12, 27
6128240001	3-Blade OEM	17 ¹¹ / ₁₆ "	22°	CW	Intake	27
6128250001	4-Blade OEM	18"	34°	CW	Intake	27
6128260001	4-Blade OEM	18"	24°	CW	Intake	27
6128270001	3-Blade OEM	24"	21°	CW	Intake	27
6128280001	3-Blade OEM	18"	26°	CW	Intake	27
6128290001	3-Blade OEM	22"	24°	CW	Intake	27
6128300001	3-Blade OEM	18"	19°	CW	Intake	27
6128310001	3-Blade OEM	22"	30°	CW	Intake	27
6128990001	2-Blade	22"	21°	CCW	Intake	8
6129170001	4-Blade	28"	29°	CW	Discharge	19
6129570001	3-Blade	22"	20°	CW	Intake	11
6129760001	3-Blade	10"	23°	CCW	Interchangeable	10
6129770001	3-Blade	10"	23°	CW	Interchangeable	10

Specifications are subject to change without notice or obligation

Lau Part Number	Model & Description						Page
6129780001	3-Blade	12"	27°		CCW	Interchangeable	10
6129790001	3-Blade	12"	27°		CW	Interchangeable	10
6129800001	3-Blade	16"	27°		CCW	Interchangeable	10
6129810001	3-Blade	16"	27°		CW	Interchangeable	10
6129820001	3-Blade	20"	24°		CCW	Interchangeable	11
6129830001	3-Blade	20"	24°		CW	Interchangeable	11
6129840001	3-Blade	22"	30°		CCW	Interchangeable	11
6129850001	3-Blade	22"	30°		CW	Interchangeable	11
6129860001	3-Blade	22"	35°		CCW	Interchangeable	11
6129870001	3-Blade	22"	35°		CW	Interchangeable	11
6129880001	3-Blade	29"	26°		CCW	Interchangeable	12
6129890001	3-Blade	29"	26°		CW	Interchangeable	12
6129900001	3-Blade	29"	33°		CCW	Interchangeable	12
6129910001	3-Blade	29"	33°		CW	Interchangeable	12
6129920001	3-Blade	30"	27°		CCW	Interchangeable	12
6129930001	3-Blade	30"	27°		CW	Interchangeable	12
6129940001	3-Blade	30"	33°		CCW	Interchangeable	12
6129950001	3-Blade	30"	33°		CW	Interchangeable	12
6129960001	4-Blade	10"	16°		CCW	Interchangeable	16
6129970001	4-Blade	10"	16°		CW	Interchangeable	16
6129980001	4-Blade	12"	16°		CCW	Interchangeable	16
6129990001	4-Blade	12"	16°		CW	Interchangeable	16
6130000001	4-Blade	14"	16°		CCW	Interchangeable	16
6130010001	4-Blade	14"	16°		CW	Interchangeable	16
6130020001	4-Blade	18"	16°		CCW	Interchangeable	17
6130030001	4-Blade	18"	16°		CW	Interchangeable	17
6130040001	4-Blade	18"	19°		CCW	Interchangeable	17
6130050001	4-Blade	18"	19°		CW	Interchangeable	17
6130060001	4-Blade	20"	14°		CCW	Interchangeable	17
6130070001	4-Blade	20"	14°		CW	Interchangeable	17
6130080001	4-Blade	20"	17°		CCW	Interchangeable	17
6130090001	4-Blade	20"	17°		CW	Interchangeable	17
6130100001	4-Blade	20"	19°		CCW	Interchangeable	17
6130110001	4-Blade	20"	19°		CW	Interchangeable	17
6130120001	4-Blade	22"	36°		CCW	Interchangeable	18
6130130001	4-Blade	22"	36°		CW	Interchangeable	18

Specifications are subject to change without notice or obligation

Lau Part Number	Model & Description					Page
6130140001	4-Blade	24"	13°	CCW	Interchangeable	18
6130150001	4-Blade	24"	13°	CW	Interchangeable	18
6130160001	4-Blade	24"	16°	CCW	Interchangeable	18
6130170001	4-Blade	24"	16°	CW	Interchangeable	18
6130180001	4-Blade	24"	18°	CCW	Interchangeable	18
6130190001	4-Blade	24"	18°	CW	Interchangeable	18
6130200001	4-Blade	24"	20°	CCW	Interchangeable	18
6130210001	4-Blade	24"	20°	CW	Interchangeable	18
6130220001	5-Blade	16"	29°	CW	Interchangeable	21
6130230001	5-Blade	16"	29°	CCW	Interchangeable	21
6130240001	5-Blade	18"	25°	CCW	Interchangeable	21
6130250001	5-Blade	18"	25°	CW	Interchangeable	21
6130260001	5-Blade	18"	31°	CCW	Interchangeable	21
6130270001	5-Blade	18"	31°	CW	Interchangeable	21
6130300001	5-Blade	20"	30°	CCW	Interchangeable	22
6130310001	5-Blade	20"	30°	CW	Interchangeable	22
6130320001	5-Blade	26"	29°	CCW	Interchangeable	22
6130330001	5-Blade	26"	29°	CW	Interchangeable	22
6130340001	5-Blade	28"	27°	CCW	Interchangeable	22
6130350001	5-Blade	28"	27°	CW	Interchangeable	22
6130360001	5-Blade	28"	29°	CCW	Interchangeable	22
6130370001	5-Blade	28"	29°	CW	Interchangeable	22
6130380001	5-Blade	28"	33°	CCW	Interchangeable	22
6130390001	5-Blade	28"	33°	CW	Interchangeable	22
6130400001	5-Blade	30"	27°	CCW	Interchangeable	22
6130410001	5-Blade	30"	27°	CW	Interchangeable	22
6130420001	5-Blade	30"	29°	CCW	Interchangeable	22
6130430001	5-Blade	30"	29°	CW	Interchangeable	22
6130440001	5-Blade	30"	33°	CCW	Interchangeable	22
6130450001	5-Blade	30"	33°	CW	Interchangeable	22
6130460001	2-Blade	14"	36°	CCW	Intake	8
6130470001	2-Blade	14"	32°	CW	Discharge	8
6130490001	2-Blade	18"	19°	CCW	Intake	8
6130500001	2-Blade	18"	24°	CW	Intake	8
6130510001	2-Blade	18"	29°	CW	Intake	8
6130520001	2-Blade	18"	36°	CW	Intake	8

Specifications are subject to change without notice or obligation

Lau Part Number	Model & Description						Page
6130530001	2-Blade	20"	23°	CCW	Intake		8
6130540001	2-Blade	20"	26°	CCW	Intake		8
6130550001	2-Blade	20"	34°	CCW	Intake		8
6130560001	2-Blade	20"	28°	CW	Intake		8
6130570001	2-Blade	24"	19°	CCW	Intake		8
6130580001	2-Blade	24"	24°	CCW	Intake		8
6130590001	3-Blade	18"	19°	CW	Discharge		10
6130600001	3-Blade	18"	22°	CCW	Intake		11
6130610001	3-Blade	18"	26°	CW	Discharge		11
6130620001	3-Blade	18"	35°	CCW	Intake		11
6130630001	3-Blade	20"	31°	CW	Discharge		11
6130640001	3-Blade	22"	24°	CW	Intake		11
6130650001	3-Blade	22"	28°	CW	Intake		11
6130660001	3-Blade	26"	37°	CW	Intake		12
6130670001	4-Blade	20"	20°	CW	Discharge		17
6130680001	4-Blade	20"	36°	CW	Intake		17
6130690001	4-Blade	22"	24°	CW	Discharge		18
6130700001	4-Blade	22"	26°	CW	Intake		18
6130710001	4-Blade	24"	29°	CW	Intake		18
6130720001	4-Blade	26"	30°	CW	Discharge		19
6130730001	4-Blade	26"	38°	CW	Discharge		19
6130740001	5-Blade	26"	29°	CW	Discharge		22
6130750001	4-Blade	28"	34°	CW	Discharge		19
6130760001	4-Blade	30"	22°	CW	Intake		19
6130770001	4-Blade	30"	40°	CW	Intake		19
6131240001	4-Blade	30"	27°	CCW	Interchangeable		19
6131250001	4-Blade	30"	27°	CW	Interchangeable		19
6131260001	4-Blade	30"	33°	CCW	Interchangeable		19
6131270001	4-Blade	30"	33°	CW	Interchangeable		19
6131430001	3-Blade	24"	22°	CW	Intake		11
6131960001	4-Blade	24"	20°	CW	Discharge		18
6132190001	3-Blade OEM	24"	20°	CW	Intake		27
6132510001	3-Blade Ag-SS	36"	30°	CW	Intake		24
6132520001	3-Blade Ag-Al	36"	19°	CW	Intake		24
6132530001	3-Blade Ag-SS	48"	30°	CW	Intake		24
6132540001	3-Blade Ag-Al	48"	30°	CW	Intake		24

Specifications are subject to change without notice or obligation

Lau Part Number	Model & Description				Page
6139520001	2-Blade Cobra	28"	20°	CCW	25
6139530001	3-Blade Cobra	28"	20°	CCW	26
6139540001	4-Blade Cobra	28"	20°	CCW	26
6139550001	2-Blade Cobra	28"	24°	CCW	25
6139560001	3-Blade Cobra	28"	24°	CCW	26
6139570001	4-Blade Cobra	28"	24°	CCW	26
6139580001	2-Blade Cobra	28"	28°	CCW	25
6139590001	3-Blade Cobra	28"	28°	CCW	26
6139600001	4-Blade Cobra	28"	28°	CCW	26
6139610001	2-Blade Cobra	28"	34°	CCW	25
6139620001	3-Blade Cobra	28"	34°	CCW	26
6139630001	4-Blade Cobra	28"	34°	CCW	26
6139700001	2-Blade Cobra	24"	20°	CCW	25
6139720001	3-Blade Cobra	24"	20°	CCW	26
6139740001	4-Blade Cobra	24"	20°	CCW	26
6139820001	2-Blade Cobra	24"	24°	CCW	25
6139840001	3-Blade Cobra	24"	24°	CCW	26
6139860001	4-Blade Cobra	24"	24°	CCW	26
6139900001	2-Blade Cobra	24"	28°	CCW	25
6139920001	3-Blade Cobra	24"	28°	CCW	26
6139940001	4-Blade Cobra	24"	28°	CCW	26
6140020001	2-Blade Cobra	24"	34°	CCW	25
6140040001	3-Blade Cobra	24"	34°	CCW	26
6140060001	4-Blade Cobra	24"	34°	CCW	26
6140160001	2-Blade Cobra	26"	20°	CCW	25
6140190001	3-Blade Cobra	26"	20°	CCW	26
6140200001	4-Blade Cobra	26"	20°	CCW	26
6140220001	2-Blade Cobra	26"	24°	CCW	25
6140250001	3-Blade Cobra	26"	24°	CCW	26
6140260001	4-Blade Cobra	26"	24°	CCW	26
6140300001	2-Blade Cobra	26"	28°	CCW	25
6140330001	3-Blade Cobra	26"	28°	CCW	26
6140340001	4-Blade Cobra	26"	28°	CCW	26
6140440001	2-Blade Cobra	26"	34°	CCW	25
6140470001	3-Blade Cobra	26"	34°	CCW	26
6140480001	4-Blade Cobra	26"	34°	CCW	26

Specifications are subject to change without notice or obligation

Lau Part Number	Model & Description	Page
6140560001	2-Blade Cobra 22" 20° CCW	25
6140570001	3-Blade Cobra 22" 20° CCW	26
6140580001	4-Blade Cobra 22" 20° CCW	26
6140600001	2-Blade Cobra 22" 24° CCW	25
6140610001	3-Blade Cobra 22" 24° CCW	26
6140620001	4-Blade Cobra 22" 24° CCW	26
6140650001	2-Blade Cobra 22" 28° CCW	25
6140660001	3-Blade Cobra 22" 28° CCW	26
6140670001	4-Blade Cobra 22" 28° CCW	26
6140710001	2-Blade Cobra 22" 34° CCW	25
6140720001	3-Blade Cobra 22" 34° CCW	26
6140730001	4-Blade Cobra 22" 34° CCW	26
Access Door	Standard	160
Access Door	CDF	161
Access Door	CDR	161
Access Door	Milcor	162
Access Door	Quick Fit	161
AL600D	Louver, Extruded Aluminum, Adjustable, Drainable	212-213
C12A	Damper, Static Fire - For <i>Fans Off</i> Systems, 1½ Hour Rating, IN	129
C12B	Damper, Static Fire - For <i>Fans Off</i> Systems, 1½ Hour Rating, OUT	130
C12LR	Damper, Static Fire - For <i>Fans Off</i> Systems, 1½ Hour Rating, OUT	131
C12R	Damper, Static Fire - For <i>Fans Off</i> Systems, 1½ Hour Rating, IN	132
C301	Damper, Commercial Control - Standard Galvanized Steel	168
C302	Damper, Commercial Control - Galvanized Steel, Low Leakage	163
C305	Damper, Commercial Control - Heavy Duty	170
C306	Damper, Commercial Control - High Performance Airfoil, Low Leakage	165
C310	Damper, Manual Balancing - Single Blade	172
C315	Damper, Commercial Control - Economy	171
C350	Damper, Commercial Control - Extruded Aluminum, Low Leakage	166-167
C400	Damper, Backdraft - Galvanized	173
C401	Damper, Backdraft - Aluminum Light & Medium Duty	174
C402	Damper, Backdraft - Aluminum Light & Medium Duty	174
C412	Damper, Backdraft - Counter Balanced Aluminum, Light Duty	176
C414	Damper, Backdraft - Counter Balanced Aluminum, Medium Duty	177
C416	Damper, Backdraft - Counter Balanced Aluminum, Heavy Duty	178
C460	Damper, Backdraft - Aluminum Heavy Duty	175

Specifications are subject to change without notice or obligation

Lau Part Number	Model & Description	Page
CCD	Damper, Ceiling Radiation - Rectangular, Surface Mount	139
CCD7	Damper, Ceiling Radiation - Rectangular, Wood Truss	140-143
CCD7-T	Damper, Ceiling Radiation - Rectangular, Wood Truss	141-143
CCD8	Damper, Ceiling Radiation- Masonry Ceilings	144
CCDR	Damper, Ceiling Radiation - Round, Surface Mount	139
CCDR5	Damper, Ceiling Radiation - Round, Diffuser, Lay-In	147
CDF	Access Door (Quick Fit) - Round & Rectangular Duct	161
CDR	Access Door (Quick Fit) - Round & Rectangular Duct	161
CFS1	Damper, Fire/Smoke Combination, 1½ Hour Rating, Class 1	181-182
CFS2	Damper, Fire/Smoke Combination, 1½ Hour Rating, Class 2	181-182
CFS2C	Damper, Fire/Smoke Combination, 1 Hour Rating, Class 2	154-156
CFSR25	Damper, Fire/Smoke Combination, 1½ Hour Rating, Class 1	152-153
CL400D	Louver, Extruded Aluminum Combination, Drainable	210-211
CL600DX	Louver, Extruded Aluminum Combination, Drainable	208-209
CP2A	Damper, Static Fire - For <i>Fans Off</i> Systems, 1½ Hour Rating, IN	123
CP2B	Damper, Static Fire - For <i>Fans Off</i> Systems, 1½ Hour Rating, OUT	124
CP2G	Damper, Static Fire - For <i>Fans Off</i> Systems, 1½ Hour Rating, IN	126
CP2LR	Damper, Static Fire - For <i>Fans Off</i> Systems, 1½ Hour Rating, OUT	125
CP2R	Damper, Static Fire - For <i>Fans Off</i> Systems, 1½ Hour Rating, IN	125
CP23A	Damper, Static Fire - For <i>Fans Off</i> Systems, 3 Hour Rating, IN	132
CP23B	Damper, Static Fire - For <i>Fans Off</i> Systems, 3 Hour Rating, OUT	133
CP23LR	Damper, Static Fire - For <i>Fans Off</i> Systems, 3 Hour Rating, OUT	134
CP23R	Damper, Static Fire - For <i>Fans Off</i> Systems, 3 Hour Rating, IN	134
CP25A	Damper, Static Fire - For <i>Fans Off</i> Systems, 3 Hour Rating, IN	135
CP25B	Damper, Static Fire - For <i>Fans Off</i> Systems, 3 Hour Rating, OUT	136
CP25LR	Damper, Static Fire - For <i>Fans Off</i> Systems, 3 Hour Rating, OUT	137
CP25R	Damper, Static Fire - For <i>Fans Off</i> Systems, 3 Hour Rating, IN	137
CPD12A	Damper, Dynamic Fire - For <i>Fans On</i> Systems, 1½ Hour Rating, IN	106
CPD12B	Damper, Dynamic Fire - For <i>Fans On</i> Systems, 1½ Hour Rating, OUT	107
CPD12LR	Damper, Dynamic Fire - For <i>Fans On</i> Systems, 1½ Hour Rating, OUT	108
CPD12R	Damper, Dynamic Fire - For <i>Fans On</i> Systems, 1½ Hour Rating, IN	108
CPD2A	Damper, Dynamic Fire - For <i>Fans On</i> Systems, 1½ Hour Rating, IN	101
CPD2B	Damper, Dynamic Fire - For <i>Fans On</i> Systems, 1½ Hour Rating, OUT	102
CPD2G	Damper, Dynamic Fire - For <i>Fans On</i> Systems, 1½ Hour Rating, IN	104-105
CPD2LR	Damper, Dynamic Fire - For <i>Fans On</i> Systems, 1½ Hour Rating, OUT	103
CPD2R	Damper, Dynamic Fire - For <i>Fans On</i> Systems, 1½ Hour Rating, IN	103

Specifications are subject to change without notice or obligation

Lau Part Number	Model & Description	Page
CPD23A	Damper, Dynamic Fire - For <i>Fans On</i> Systems, 3 Hour Rating, IN	112
CPD23B	Damper, Dynamic Fire - For <i>Fans On</i> Systems, 3 Hour Rating, OUT	113
CPD23LR	Damper, Dynamic Fire - For <i>Fans On</i> Systems, 3 Hour Rating, OUT	114
CPD23R	Damper, Dynamic Fire - For <i>Fans On</i> Systems, 3 Hour Rating, IN	114
CPD25A	Damper, Dynamic Fire - For <i>Fans On</i> Systems, 3 Hour Rating, IN	115
CPD25B	Damper, Dynamic Fire - For <i>Fans On</i> Systems, 3 Hour Rating, OUT	116
CPD25LR	Damper, Dynamic Fire - For <i>Fans On</i> Systems, 3 Hour Rating, OUT	117
CPD25R	Damper, Dynamic Fire - For <i>Fans On</i> Systems, 3 Hour Rating, IN	117
CPD35	Damper, Dynamic Fire - For Fans On Systems, 1½ Hour Rating, IN	109
CPDR25	Damper, Dynamic Fire - For Fans On Systems, 1½ Hour Rating, IN	110-111
CPT, T1, T2A	Damper, Static Fire - For Fans Off Systems, 1½ Hour Rating, IN	127-128
CPT, T1, T2B	Damper, Static Fire - For Fans Off Systems, 1½ Hour Rating, OUT	127-128
CR307	Damper, Manual Balancing - Single Blade	172
CRBD2	Damper, Backdraft - Round	179
CRS25	Damper, Commercial Control - Round, Low Leakage	169
CSD36	Damper, Smoke, Class 2	158
CSD37	Damper, Smoke, Class 1	157
CSDRS25	Damper, Smoke, Class 1	159
CSE20	Louver, Extruded Aluminum, Thin Line Stationary	199
CSE20D	Louver, Extruded Aluminum, Thin Line Stationary, Drainable	200
CSE400	Louver, Extruded Aluminum, High Performance Stationary	205
CSE400D	Louver, Extruded Aluminum, High Performance Stationary, Drainable	204-205
CSE600	Louver, Extruded Aluminum, High Performance Stationary, Drainable	206
CSE600D	Louver, Extruded Aluminum, High Performance Stationary, Drainable	207
CSE800	Louver, Extruded Aluminum, General Purpose Stationary	201
CSE800D	Louver, Extruded Aluminum, General Purpose Stationary, Drainable	202
DSDF	Smoke Detector, Flow Duct	185-188
DSDN	Smoke Detector, No Flow Duct	189-192
G074010012	Belt Length Finder, Model 91004	87
G074010013	Pulley Gauge, Model 13998M	87
G074010014	Pulley Gauge, Model 13998 t	87
G074010071	Krikkit Gauge	87
G074010072	Krikkit Gauge	87
G074010075	Tension Tester, Double Barrel, 66 lbs.	87
G074010076	Tension Tester, Pencil Type, 30 lbs.	87
G074010079	Tension Tester, Five Barrel, 165 lbs.	87

Specifications are subject to change without notice or obligation

Lau Part Number	Model & Description	Page
G074200204	Flexible Sensor, Model 204	87
G074200206	Cord Sensor, Model 206	87
G074200208	A/C Adapter, Model 208	87
G074200212	Inductive Sensor Belt Length Finder	87
G074200507	Sonic Tension Meter, Model 507C	87
G074201000	EZ Align, Laser Tool	87
Integral Sleeves & Retaining Angles (FAST & PFMA)		184
LAD	Air Curtain (without Electric Heater)	215
LAD-36, 42, 48, 64, 78	Air Flow & Sound Performance Data	217
LHAD	Air Curtain (with Electric Heater)	216
LHAD-36, 42, 48, 64, 78, 84	Motors, Heaters & Control Box Data	217
MCP Control Panels (MCP1, MCP14, MCP2 & MCP24)		194
MCP Control Panels (MCP10, MCP104, MCP20 & MCP204)		195
Replacement Fuse Links (Styles A-B-J)		183
SP100	Switch Package	196-197
TS150	Firestat For Re-Openable Fire & Smoke Dampers	193

QUALITY STATEMENT

We will provide products and services, which meet or exceed all customer expectations by assuring a work environment where all Lau employees contribute to continuous improvement.

A WORD ABOUT LAU PARTS DIVISION

For over 75 years, Lau has been a dedicated service and manufacturing supplier to the major original equipment manufacturers; both large and small. That's a long time and quite a testament to Lau's commitment and stability in a very challenging market. We were here to serve our customers; not only yesterday, but we are here now, into and throughout the 21st Century!

Lau's Parts Division is the only manufacturer in the market dedicated to the replacement business. We supply Universal Replacement Propellers, Blower Assemblies & Wheels, Gates V-Belts & Pulleys, Edgar Lau Premium Signature Series Motors, Emerson Replacement Motors, fire dampers, extruded aluminum louvers, plus related components for over 50 years.

Lau Parts Division's focus has always been on the HVAC/R Wholesalers, Appliance and Electric Motor Distributors, as well as the Service Technician. Our replacement products are designed and engineered to keep SKU numbers to a minimum, replace and hold up to the most rugged handling, and withstand the increased workload you expect of a quality replacement product.

For more information, contact your local Lau Parts Division wholesaler or sales representative. If you need help locating a source for Lau products, call us at: **937.253.2000** or visit us on our website at: **www.lauparts.com**.

Thank you for your continued support by demanding top quality at competitive prices ... by demanding Lau!

WARRANTY

Lau warrants that its products will be in accordance with Lau drawings and specifications as approved by the customer and in accordance with the samples and models furnished, if any. Other than the warranties recited herein, no express or implied warranties shall attach to any purchase order resulting therefrom, unless otherwise specifically set forth in writing. In the event of a breach of any of these conditions, Vendor's warranty covers only defects in workmanship or materials for a period of one (1) year, from date of manufacture plus six (6) months allowance for warehousing, with liability being limited to replacement or repair of defective parts, furnished by Vendor, excepting motors and electrical components which are warranted by the manufacturers of such equipment. Vendor's warranty is IN LIEU OF ALL OTHER WARRANTIES EXPRESS OR IMPLIED INCLUDING WARRANTIES OF MERCHANTABILITY AND FITNESS FOR PURPOSE.

AS A RESULT OF VARIABLES, including but not limited to vibration, noise characteristics, possible over loading of motors, performance under low voltage conditions, and variations in systems, over which Vendor has no control, NO WARRANTY IS MADE AS TO THE FITNESS OF VENDOR'S COMPONENTS FOR A PARTICULAR PURPOSE. The customer is, therefore, responsible for the final selection and application of Vendor's components in his product; and, the customer's skill and judgment in such selection and application, as well as in inspection and testing, is relied upon by all parties. The purchaser, by this acceptance of products purchased, also assumes all liability for the consequence of performance application, use, and/or misuse by the purchaser, his employees, and/or his customers, and no damages whether incidental, consequential or otherwise, are covered by this warranty, nor are they the liability of the Vendor.



Moving Air is Our Business!

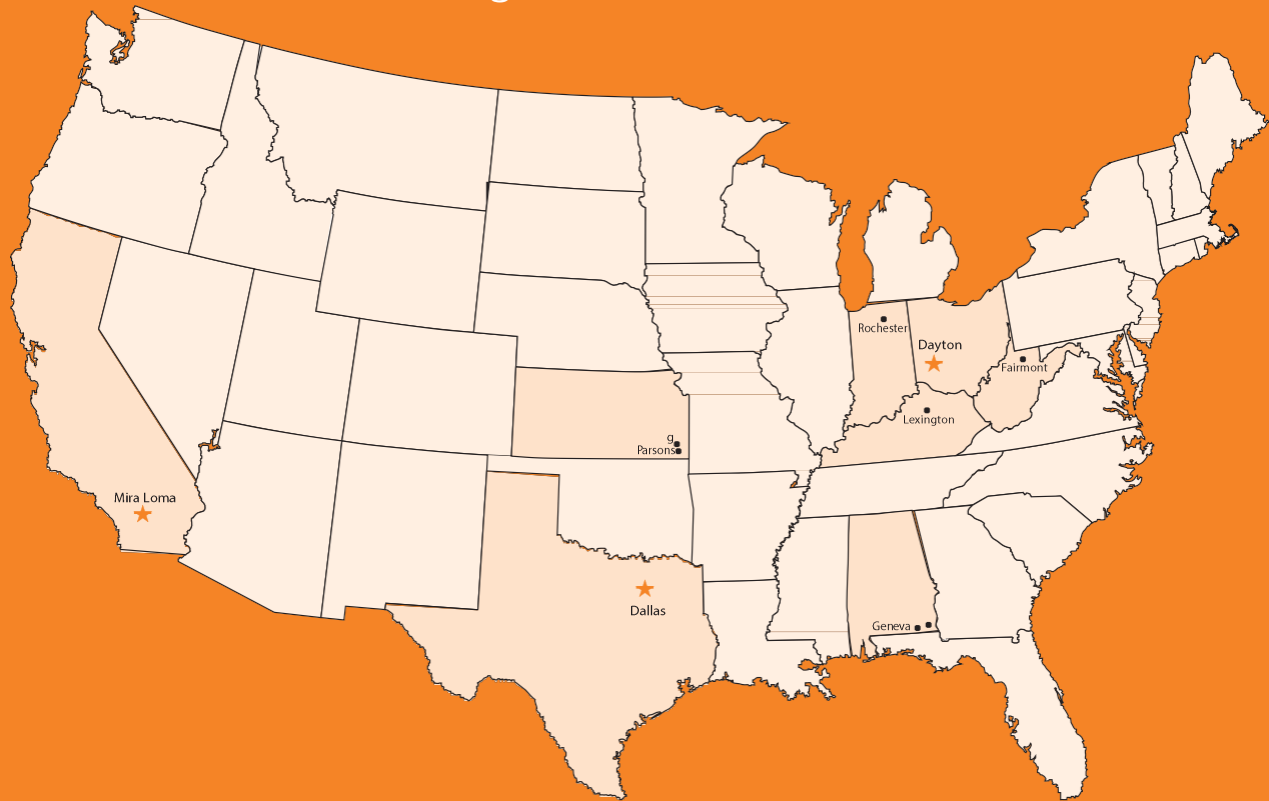

**Sales Office
Lau Parts Division**

4509 Springfield St. • Dayton, OH 45431
Phone: 937-253-2000 • Fax: 937-252-9169
www.lauparts.com
Business hours: 8am-5pm Eastern time

Represented By:

Distribution Locations

Parsons, Kansas • Mira Loma, CA • Fairmont, West Virginia
Lexington, Kentucky • Dallas, TX
Geneva, Alabama • Rochester, Indiana (Central Distribution)