

Installation Instructions



InnoFlue® Single Wall, Flex, Concentric Vent System

The installation instructions should be kept with the appliance for maintenance.

Examine all components for possible shipping damage prior to installation.

Do not mix products or instructions from multiple manufacturers.

Different manufacturers utilize different methods for joining vent sections. Proper joint assembly is essential for a safe installation. Follow these instructions exactly as written. Check integrity of joints upon completion of assembly.

InnoFlue® must be free to expand and contract and must be supported in accordance with these instructions.

Check for unrestricted vent movement through walls, ceilings, and roof penetrations.

We are proud that **InnoFlue®** conforms to:

UL-1738

ULC-S636



Scan for training videos

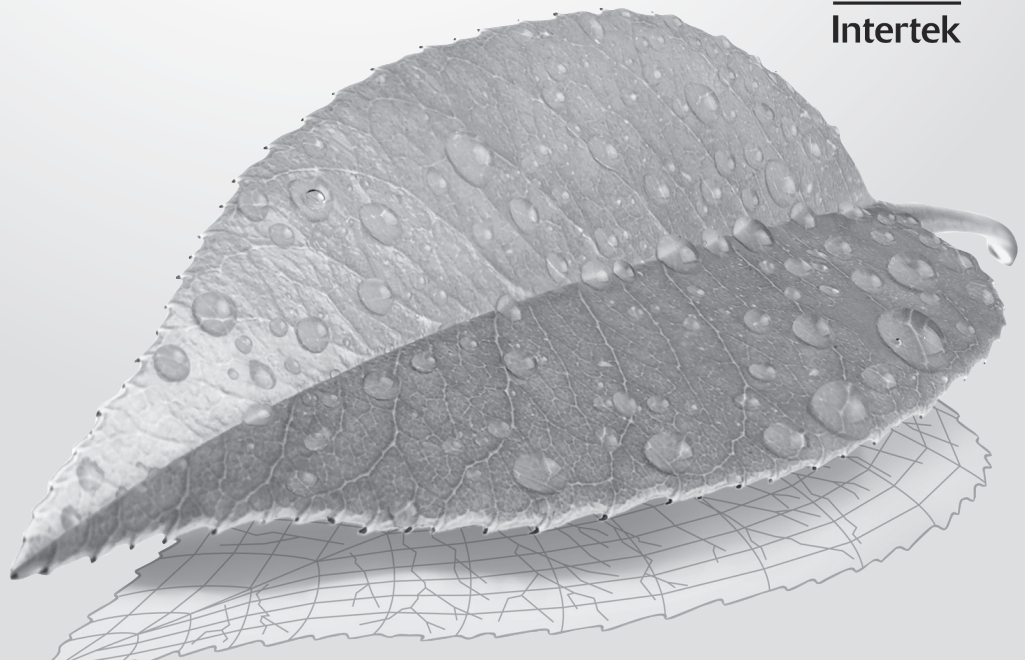

Contents

Introduction	3
General Installation Guide Lines	3
Gasket placement	4
Field Cutting InnoFlue® Rigid Vent Lengths	4
Field Cutting InnoFlue® Flex	4
Joint Connections	5
Vent Support Horizontal.....	5
Vent Support Vertical	5
Vent Pitch	5
InnoFlue® Condensate Drains.....	6
Vertical Installation (Rigid, Through the Roof).....	6
Vertical Installation (Rigid or Flexible, Through a Masonry Chimney)	7
Vertical Termination (InnoFlue® Flex, Masonry Chimney)	8
Vertical Termination (InnoFlue® Rigid, Masonry Chimney)	8
Vertical Installation (InnoFlue® Flex, Into an Existing B-Vent).....	9
Horizontal Single Wall, Through the Wall Installation.....	10
Horizontal Single Wall Vent Terminations.....	10
InnoFlue® Flame & Smoke Spread Rating Assembly	11
InnoFlue® Fire Rated Wall/Ceiling Penetration Assembly.....	12-13
Basic Concentric Installation.....	14
Horizontal Concentric Vent System	15
Vertical Concentric Vent System	16

Introduction

The InnoFlue® Vent System is manufactured from polypropylene. It has been tested and listed by Intertek to UL-1738 and ULC-S636 for use with Category II and IV (US) and Gas-Vent-BH, Class II C (Canada) Residential, Commercial and Industrial gas fired appliances. InnoFlue® is UL-1738 & ULC-S636 rated for use with maximum flue gas temperatures of 230°F (110°C). NOTE: Centrotherm warrants InnoFlue® up to a sustained maximum flue gas temperature of 248°F (120°C). InnoFlue® is rated to a maximum vent pressure of .725 psi (5000 Pa) or 20" of water column.

As part of regular equipment maintenance, check for vent system integrity and blockage.

All installations must conform to all relevant Local, State and National codes. In the US: National Fuel Gas Code ANSI-Z223.1, NFPA 54, NFPA 211. In Canada: CAN/CGA-B149.1 or CAN/CGA-B149.2. Permits may be required before an installation can begin.

Before installation, each vent component must be inspected for possible shipping damage and correct seal placement. These installation instructions must be read, understood and complied with.

These installation instructions comply with UL-1738 and ULC-S636. Refer to the appliance manufacturer's installation instructions for appliance adaptors, terminations and maximum allowable vent length. For UL-1738 & ULC-S636 approved InnoFlue® components, consult the InnoFlue® catalog at www.centrotherm.us.com.

InnoFlue® vent components must be used throughout the entire vent system. **Do not mix with other vent manufacturer's products.**

General Installation Guide Lines

Property damage, personal injury or death can result if these instructions are not followed. They are a guide for professional installers generally familiar with the installation and maintenance of heating equipment and related vent systems.

- Do not install InnoFlue® where ambient air temperature can exceed 300°F (148°C).
- InnoFlue® can be installed at zero clearance to combustible materials.
- Masonry chimneys or existing B-vents can be used as passage ways for InnoFlue®, provided that no other appliances are or will be connected.
- Appliances can be fired up immediately after an InnoFlue® vent system is installed and inspected.
- Free standing components (i.e. above the roof) may not exceed a maximum vertical height of 59" (1.5m) without additional support.
- Unless approved by the appliance manufacturer, only one appliance may be connected to a vent system.
- A Condensate Drain must be installed in the vent system as close to the flue outlet as possible unless the appliance is designed to manage condensate.
- All penetrations of fire rated walls/ceilings shall be sealed using fire stops that are approved for such use and must be installed according to this manual and the passive fire stop manufacturers installation instructions.
- When using InnoFlue® Flex, the vent capacity of an appliance must be reduced by 15% when calculating its proper vent diameter unless otherwise stated by the appliance manufacturer.
- Both rigid and flexible InnoFlue® systems expand and contract slightly during heating cycles and must be installed following these instructions.
- InnoFlue® can be painted. Use of an adhesion promoter that is specifically recommended for use with polypropylene is allowed.
- Use of Centrotherm supplied supports is strongly recommended. In instances where Centrotherm supports are not suitable, field supplied supports that are of clam shell design and have a minimum threaded rod diameter of 5/16" (8mm) are permissible.
- InnoFlue® Flex can be sloped a maximum of 45° off of vertical, ie minimum of 45° off of horizontal.
- If InnoFlue® Flex is installed when the outside temperature is less than 32°F (0°C), install liner from bottom of chase. Keep InnoFlue® Flex greater than 32°F (0°C) during installation.
- For exterior components only, a single stainless steel screw may be used to fix direction of vent.
- Rain Caps are not required.

Installation Instructions

GASKET PLACEMENT

- Gaskets are factory installed in all InnoFlue® components.
- If a gasket is missing or damaged, it must be replaced by a correctly sized, Centrotherm supplied gasket.
- Make sure gasket bead and gasket itself is clean, then insert the new gasket as per drawing.
- Gasket must fit evenly within the gasket bead.

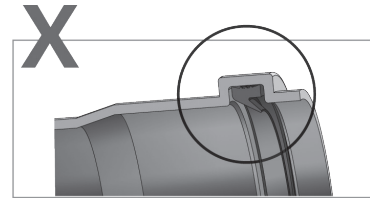
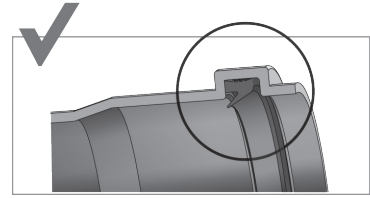

FIELD CUTTING INNOFLUE® RIGID VENT LENGTHS

- Use trade tools such as a hack saw to create a perpendicular, clean cut.
- Deburr cut end so that damage to the gasket is avoided.
- Remove debris from inside the pipe prior to assembly.

FIELD CUTTING INNOFLUE® FLEX

- 3" and 4" Flex feature rigid sections. At base of chase, leave a full rigid section to seat into the Base Support.
- Use trade tools such as a hack saw to create a perpendicular, clean cut at the bottom of the rigid section.
- 2" Flex is corrugated. Use a razor knife to cut. Only cut inside corrugation recess.
- Deburr cut end so that damage to the gasket is avoided. Use Reed Manufacturing DEB4 equivalent.
- Remove debris from inside the pipe prior to assembly.

CAUTION: Damaged gaskets can cause leakage of dangerous levels of carbon monoxide or property damage due to condensate leaks!

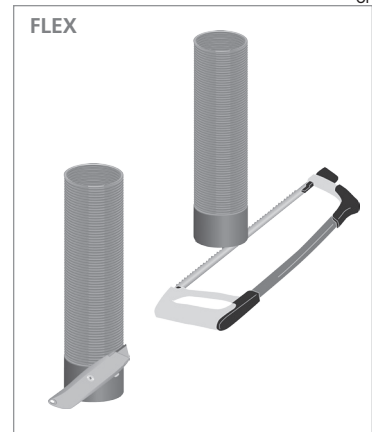
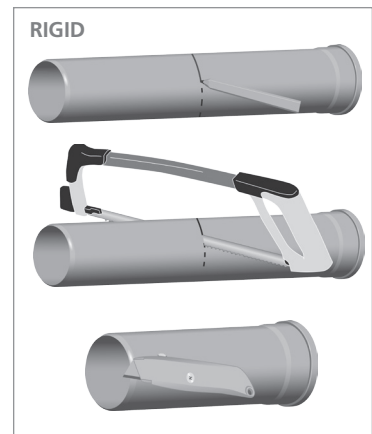

JOINT CONNECTIONS

- Each female-end of every InnoFlue® vent length or component features a factory installed gasket. Before assembly, make sure gaskets are in place correctly.
- Measure the depth of the female socket. Mark* the male-end of each component just shy of the depth of the female socket from its end.
- Place a thin layer of Centrocerin, a water based lubricant onto the male end of component 2 for ease of assembly.
- Slip a Connector Ring over the male end of component 2 so that it can grip the gasket bead of component 1.
- Push and twist male end until properly seated in component 1, aligning the mark* with the top of the female end.
- Clip the Connector Ring onto the gasket bead to secure the two components to each other.

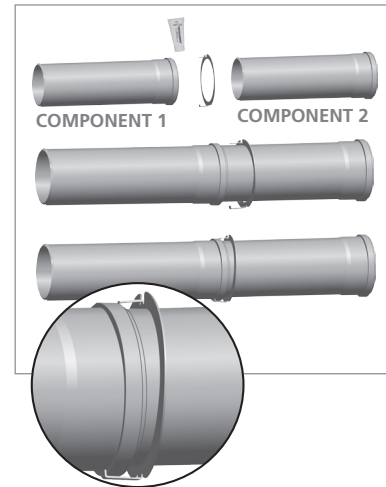

NOTE: to meet requirements of ULC-S636 & UL-1738, only InnoFlue® Vent Systems of 2", 3", 4" and 5" diameters must utilize Connector Rings.

VENT SUPPORT HORIZONTAL

- Use only rigid vent lengths for horizontal vent configurations.
- Install Support Brackets onto solid ceiling joists or surfaces.
- Space Support Brackets no more than 39" (1m) apart.
- Use additional Support Brackets at directional changes such as Elbows or Tee sections as needed.

VENT SUPPORT VERTICAL

- Use only rigid vent lengths for vertical, wall mounted vent configurations.
- Install Support Brackets onto solid wall studs or surfaces.
- Space Support Brackets no more than 78" (2m) apart.
- Use additional Support Brackets at directional changes such as Elbows or Tee sections as needed.

VENT PITCH

- Male ends of all components must point and pitch back towards the appliance to assure free condensate flow to the Condensate Drain of the appliance or vent system.

Diameters 2", 3" & 4" with Long Sockets (Designated with Asterisk (*) post fix)

- Vent Lengths with an asterisk (*) post fix in the sku used in a horizontal vent configurations must be pitched towards the appliance and at an angle of no less than one 1° or 1/4"/ft. To use this reduced pitch, all vent lengths in the horizontal run must be of the long socket design which is indicated by the asterisk (*) post fix.

While you may mix standard and long socketed pipes, if they are mixed in a horizontal run, that section must be at an angle of no less than 3° or 5/8"/ft (5.6cm/m).

Diameters 2", 3", 4", 5", 6", 8", 10" & 12" with standard sockets

- Horizontal vent configurations must be pitched towards the appliance and at an angle of no less than 3° or 5/8"/ft (5.6cm/m).

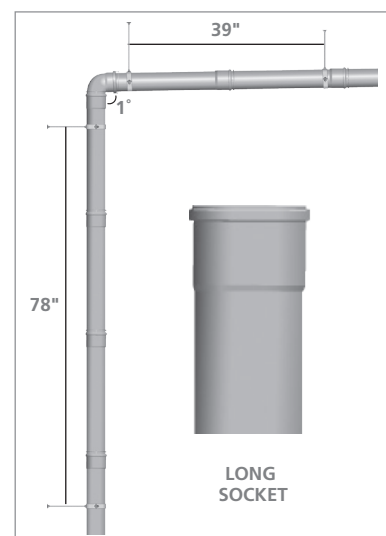
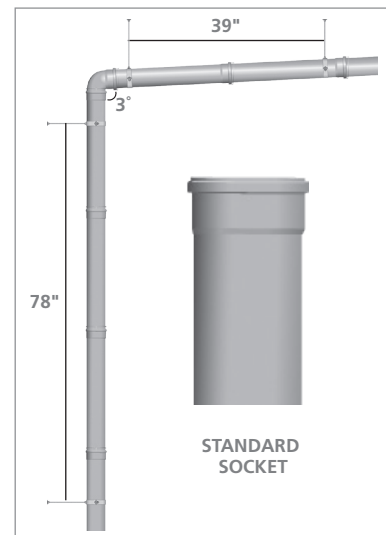

Installation Instructions

INNOFLUE® CONDENSATE DRAINS

InnoFlue® Siphons

- When using a Condensate Drain with the InnoFlue® Siphon, slide it on to the Condensate Drain nipple, attach a 3/4" plastic tube to its outlet and lead it to an appropriate condensate disposal location.
- Fill this siphon with water before appliance start-up.

Tube Siphons

- As an alternative, use a 1 1/4" (32mm) plastic tube to create and secure a loop (siphon), fill loop with water, then affix the tube onto the Condensate Drain nipple and lead tube to an appropriate condensate disposal location such as a sanitary sewer drain.
- Consult appliance manufacturer's instructions for additional requirements in regards to condensate drains.

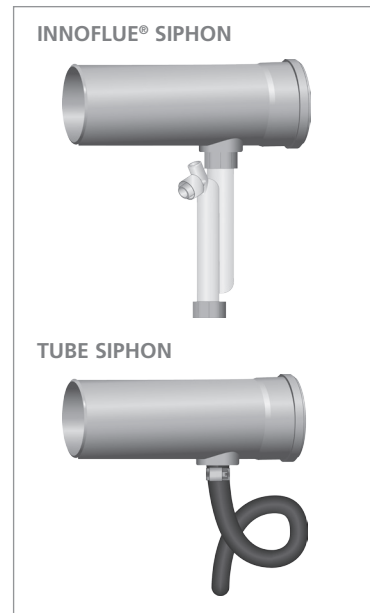

VERTICAL INSTALLATION (RIGID, THROUGH THE ROOF)

- InnoFlue® can be installed at zero clearance to combustible materials.
- Install the appliance adaptor as approved by the appliance manufacturer.
- Add vent lengths, elbows and condensate drain(s) as needed to reach the final vertical vent run.
- If horizontal run is more than 39" (1m), install Support Brackets onto solid ceiling joists or surfaces.
- Pitch any horizontal portion of the vent system at an angle of no less than three degrees or 5/8"/ft (5.6cm/m) towards the appliance.
- Install a Support Bracket at any change in direction.
- On vertical runs, install Support Brackets no more than 78" (2m) apart.
- Install Support Brackets onto solid wall studs or surfaces.
- Opening in roof deck should be cut slightly larger than the vent diameter.
- Terminate standard vent pipe so that the top female end remains below the roof flashing.
- Insert End Pipe (black) into the top of the standard vent pipe.
- Slip an approved Roof Boot (such as Oatey) or custom flashing over the End Pipe.
- Follow the instructions of the Flashing manufacturer to correctly seal the roof penetration.
- Insert a Bird Screen into End Pipe (per local code).
- Vertical termination greater than 59" (1.5m) beyond the roof line must be supported by braces or guy wires.

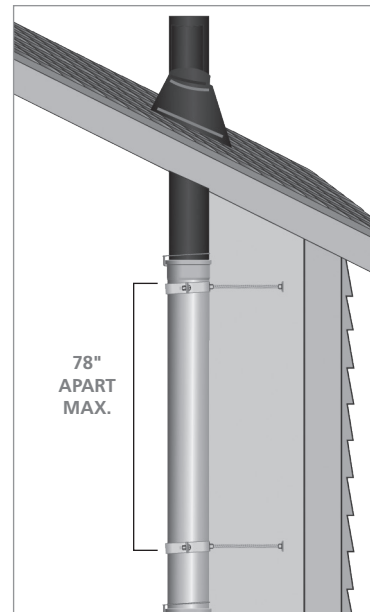

VERTICAL INSTALLATION (RIGID OR FLEXIBLE, THROUGH A MASONRY CHIMNEY)

- When using a masonry chimney as a passageway for InnoFlue® Rigid or Flex, the chase must be structurally sound and free of any debris or obstructions.
- If only supported with a Base Support at the bottom, the maximum continuous vertical vent length for a rigid InnoFlue® vent system cannot exceed 164' (50m).
- If only supported with a Base Support at the bottom and a standard chimney cover at the top, the maximum continuous vertical vent length for a flexible InnoFlue® vent system cannot exceed 98' (30m).
- Multiple InnoFlue® vent or air intake systems can be installed into one chase.
- Affix Spacers onto each vent or air intake (offset them), then pull or lower them individually or bundled into the chase.
- To avoid condensate pooling and damage to vent, InnoFlue® Flex offsets cannot exceed 45°. Multiple offsets are allowed in a chase.
- Both rigid and Flex expand slightly during normal operation. Rigid pipe can expand upwards through the Chimney Cover, Flex slightly diverts from vertical.
- Install a Base Support bracket just below the entry point into the chase.
- When cutting InnoFlue® Flex to length, the rigid section fits into the female end of any InnoFlue® component (i.e. Base Support for 3" & 4" diameters).
- When measuring for Flex length from the Base Support, add at least 2' above the chimney top.
- Measuring from the Base Support, attach Spacers at intervals of 78" (2m) or less to the rigid or flex pipe.

NOTE: Spacers serve to keep InnoFlue® Rigid or Flex away from rough surfaces and so avoid damage to the pipe during installation or normal operation. They do not have a support function. Attach Spacers to the pipe even if the chase is larger than the reach of the Spacers.

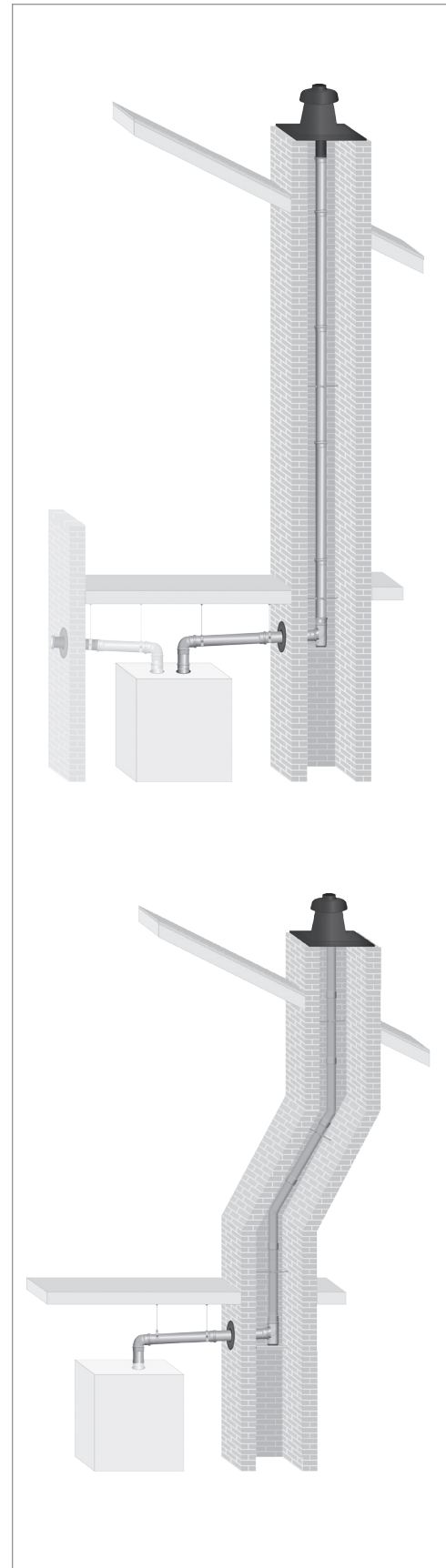
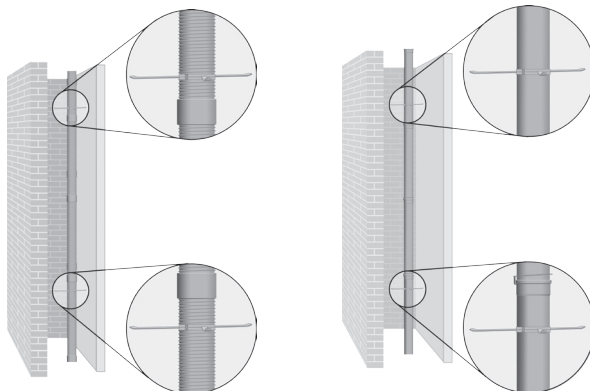

VERTICAL INSTALLATION (RIGID OR

Installation Instructions

FLEXIBLE, THROUGH A MASONRY CHIMNEY) (CONT.)

- Pull assembled rigid sections (see *Joint Connections*) or InnoFlue® Flex up to the top (lowering from the top is an option, see *Installation Tool*).
- For 3" and 4" diameter InnoFlue® Flex, cut the liner at at the bottom of the nearest rigid section. For 2" InnoFlue® Flex, attach a Single Wall to Flex Coupler. (See *Field Cutting InnoFlue® Flex*).
- Slip a Connector Ring over the bottom of the vent pipe (see *Joint Connections*).
- Seat male end of the rigid vent pipe or the rigid section of InnoFlue® Flex into the Base Support (see *Joint Connections*).
- Click the Connector Ring onto the base support.
- Insert Stem of base support into base support bracket. Install lock washer onto stem.
- From the Base Support, make the connection to the appliance with rigid components, following *Horizontal Installation* instructions.
- Use a Wall Plate to seal masonry around vent pipe.
- Do not mortar vent. Mortar adversely effects vent.

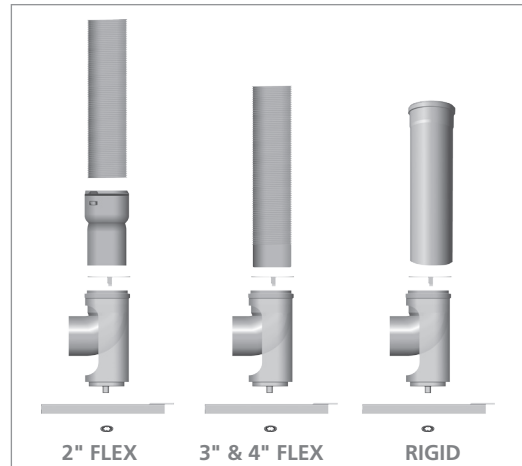

VERTICAL TERMINATION (INNOFLUE® FLEX, MASONRY CHIMNEY)

- InnoFlue® Flex should now extend about 2' above the masonry.
- Slip the Chimney Cover over flex pipe.
- Anchor the Chimney Cover to the masonry with screws (provided) and silicone. Pre-drill masonry with 3/16" ø (5mm ø) size bit. .
- Slip the Flex End Pipe Locking Ring over the flex pipe and seat into slot at the top of the Chimney Cover.
- Trim Flex pipe flush with Flex End Pipe Locking Ring.
- Twist Flex End Pipe into the top of the Chimney Cover/ Flex Pipe/Locking Ring.
- Push Cap over End Pipe until it snaps in place.
- Insert a Bird Screen into Flex End Pipe (per local code).

VERTICAL TERMINATION (INNOFLUE® RIGID, MASONRY CHIMNEY)

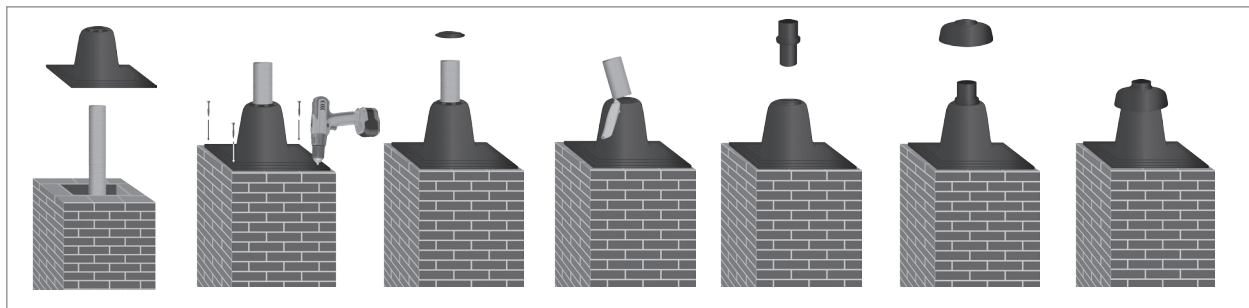

- Terminate standard vent pipe so that the top female end remains below the top of the Chimney Cover.
- Insert End Pipe (black) into the top of the standard vent pipe.
- Slip the Chimney Cover over End Pipe.
- Anchor the Chimney Cover to the masonry with screws (provided) and silicone. Pre-drill masonry with 3/16" ø (5mm ø) size bit.
- Insert a Bird Screen into End Pipe (per local code).

VERTICAL INSTALLATION (INNOFLUE® FLEX, INTO AN EXISTING B-VENT)

When using an existing B-vent system as a passageway for InnoFlue® Flex, follow the general instructions for *Vertical Installation through a masonry chimney*, then terminate the vent system as follows:

Bottom Termination (InnoFlue® Flex, B-Vent)

- Remove the Rain Cap from the B-Vent chase top.
- Remove horizontal B-vent sections back to the vertical support box.
- Make sure the B-vent between its new bottom and top is in good condition and unobstructed throughout.
- Install InnoFlue® Flex through the B-Vent leaving 2' flex above top of B-Vent and temporarily secure at both ends.
- Assemble Base Support and InnoFlue® Flex as per *Vertical Installation through a masonry chimney*.
- Lower the Base Support so that its stem is securely seated into the hole of the B-Vent Support Bracket. Install lock washer onto stem.
- Use two fasteners per side to affix the B-Vent Support Bracket to the ceiling joists.
- From the Base Support, make the connection to the appliance with rigid components, following *Horizontal Installation Instructions*.

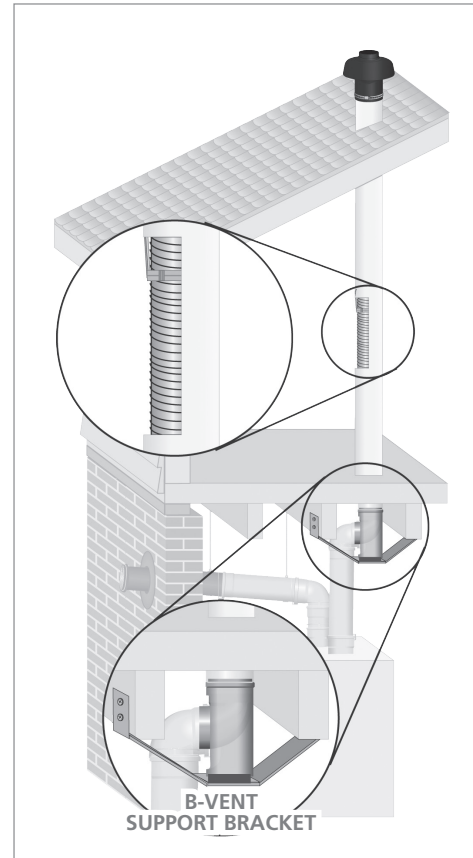

Top Termination (InnoFlue® Flex, B-Vent)

- InnoFlue® Flex should now extend about 2' above the B-Vent chase.
- Slip the B-Vent Cover over flex pipe.
- Tighten hose clamp on B-Vent Cover.
- Slip the Flex End Pipe Locking Ring over the flex pipe and seat into slot at the top of the B-Vent Cover.
- Trim Flex pipe flush with Flex End Pipe Locking Ring.
- Twist Flex End Pipe into the top of the B-Vent Cover/ flex pipe locking ring.
- Push Cap over End Pipe until it snaps in place.
- Insert a Bird Screen into Flex End Pipe (per local code).

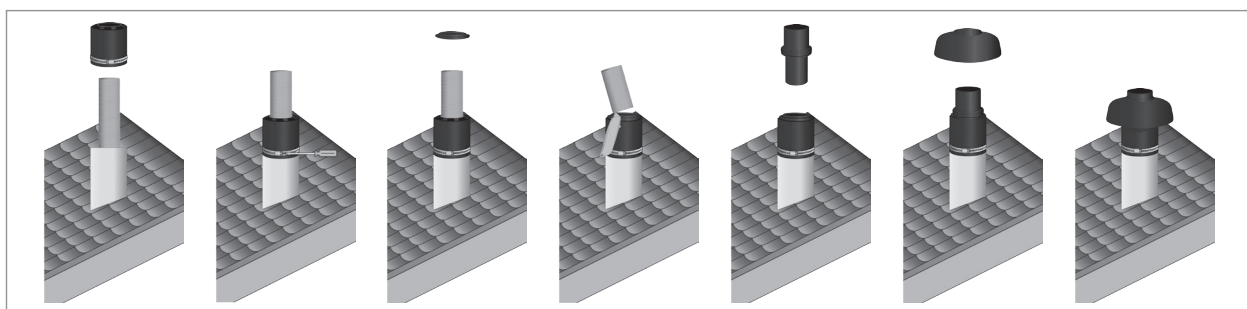

Installation Instructions

HORIZONTAL SINGLE WALL, THROUGH THE WALL INSTALLATION

- Total equivalent vent length may not be greater than specified in the appliance manufacturer's instructions.
- Find the best suitable spot to penetrate the wall based on ANSI Z223.1/NFPA54 specifications. Consult drawing table for permitted Vent Terminal (V) locations.
- As InnoFlue® can be installed at zero clearance to combustibles, cut a hole (key hole saw) slightly larger than the OD of the gasket bead.
- For horizontal vent configurations, use rigid InnoFlue® components only.
- For air intake, InnoFlue® Rigid or Flex may be used.
- If horizontal run is more than 39" (1m), install Support Brackets onto solid ceiling joists or surfaces.
- Pitch any horizontal portion of the vent system at an angle of no less than three degrees or 5/8"/ft (5.6cm/m) towards the appliance.
- Install the appliance adaptor as approved by the appliance manufacturer.
- Add vent lengths, elbows and condensate drain(s) as needed to reach the wall penetration (see *Joint Connections*).
- If the vent termination is in an area that will be exposed to direct sun light, Centrotherm recommends the use of UV stabilized vent components (black) outside the building.
- Seal the wall area around the vent with silicone.

HORIZONTAL VENT TERMINATIONS

- If going straight through a wall, the vent cannot extend more than 12" (305mm) from the wall's exterior.
- Termination Tees, 45° or 90° elbows may be used to direct flue gases in desired directions.
- Snorkel configurations may be used when wall penetration does not meet "V" location specifications.
- Any vertical portion of a vent or air intake that is outside the building must be secured to the building with Support Clamps.
- Install Bird Screens into any exterior vent or air intake opening (optional).
- For concentric wall termination allowing for a single wall penetration.
 - Install a Twin Pipe to Concentric Adaptor to co-locate vent and air intake inside the building.
 - Add a Concentric Wall Termination to go through the wall.
 - See Concentric section for installation instructions.

CAUTION
 Maintain 12" of clearance above the highest anticipated snow level or grade or whichever is greater. Please refer to your local codes for the snow level in your area.

REF	DESCRIPTION	U.S. INSTALLATIONS	CANADIAN INSTALLATIONS
A	Clearance above grade, veranda, porch, deck, or balcony	1 foot	1 foot (0,30 m)
B	Clearance to window or door that may be opened	1 foot	3 feet (0,91 m)
C	Clearance to permanently closed window	*	*
D	Vertical clearance to ventilated soffit, eaves or overhang	*	*
E	Clearance to unventilated soffit, eaves, or overhang	*	*
F	Clearance to outside corner	*	*
G	Clearance to inside corner	*	*
H	Clearance to each side of center line extended above meter/regulator assembly	*	3 feet (0,91 m) within a height 15 feet (4,57 m) above the meter/regulator assembly
I	Clearance to service regulator vent outlet	*	3 feet (0,91 m)
J	Clearance to nonmechanical air supply inlet to building or the combustion air inlet to any other appliance	1 foot	3 feet (0,91 m)
K	Clearance to a forced air inlet into a building	3 feet above if within 10 feet horizontally	6 feet (1,83 m)
L	Clearance above paved sidewalk or paved driveway located on public property	*	7 feet (2,13 m)
M	Clearance under deck, veranda, porch, or balcony (open on 3 sides)	*	1 foot (0,30 m)

*For clearances not specified in ANSI Z223.1 / NFPA 54 or CGA-B149, please use clearances in accordance with local installation codes and the requirements of the gas supplier.

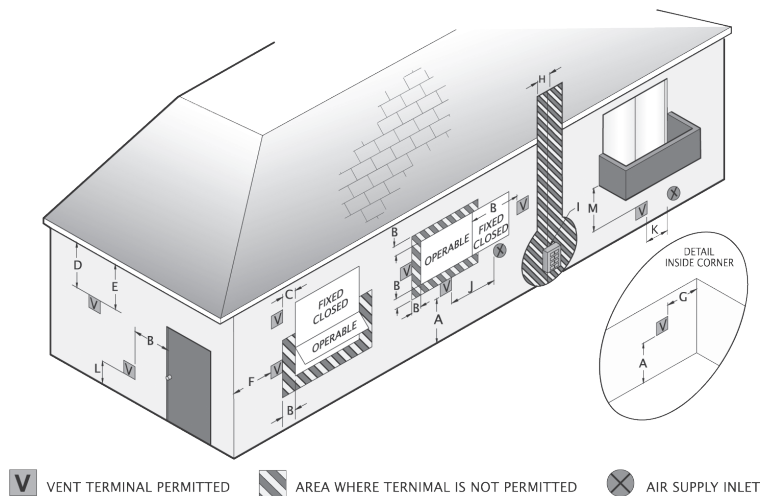

INNOFLUE® FLAME & SMOKE SPREAD RATING ASSEMBLY INSTRUCTIONS

InnoFlue® meets flame spread index and smoke developed index of <25 / <50 per UL-723, ASTM E-84 and ULC-S102. To meet these standards, InnoFlue® must be wrapped with a UL-723, ASTM E-84 or ULC-S102 listed material designed for use with plastic piping.

MATERIAL: Friendly Feel® Duct Wrap with ECOSE® Technology, 3M™ Fire Barrier Plenum Wrap 5A+, Unifrax FyreWrap® 0.5 Plenum Insulation or equivalent.

Generic installation instructions are included. **Please follow the specific pipe wrap manufacturer's installation instructions.**

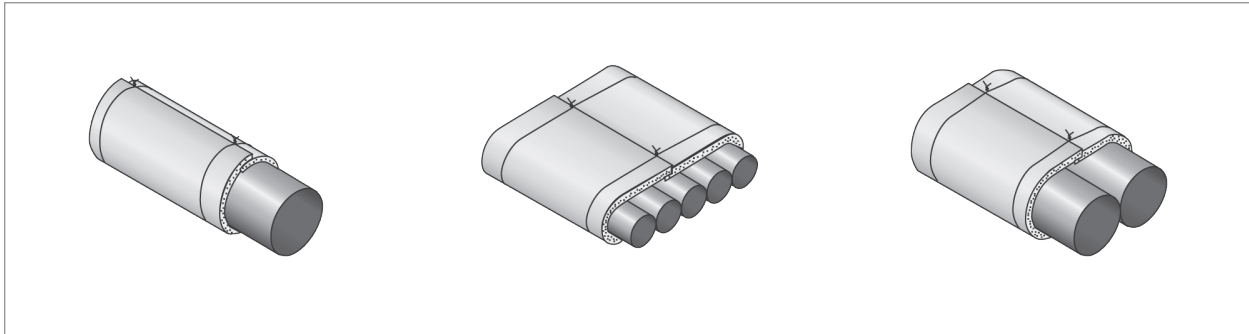

INSTALLATION INSTRUCTIONS:

- Follow Centrotherm's InnoFlue® standard installation instructions.
- Vent supports are installed after the pipe has been wrapped.
- Install Wrap with facing to the outside.
- Butt all insulation joints firmly together. Longitudinal seam of the vapor retarder must be overlapped a minimum of 2" (51 mm). A 2" (51 mm) tab is provided for the circumferential seam and must be overlapped.
- Where vapor retarder performance is necessary, all penetrations, joints, seams and damage to the facing should be sealed with an FSK, PSK or foil tape or glass fabric and mastic prior to system startup.
- Pressure sensitive tapes should be a minimum of 3" (76 mm) wide and be applied with moving pressure using an appropriate sealing tool.
- Closure systems should have a 25/50 F.H.C. per UL 723.
- Unfaced Duct Wrap should be overlapped with a minimum of 2" (51 mm) and secured with a wire or banding system. Care must be taken to avoid damaging the duct wrap. Refer to diagram for butt-joint method.

Installation Instructions

INNOFLUE® FIRE RATED WALL/CEILING PENETRATION ASSEMBLY

InnoFlue® Single Wall Polypropylene Vent Systems can be used in areas that require a one or two hour fire rating per ASTM E-814, UL 1479 or ULC S115 when used with a listed passive fire protection system. Approved passive fire protection system manufacturers include PFP Partners and 3M. The Passive Fire Protection System Manufacturer's installation instructions should be followed at all times.

PFP PARTNERS:

InnoFlue® 2" through 6" diameter single wall venting has been tested and listed with PFP Partners Passive Fire Stopping Products for a 2 hour fire rating.

Passive Fire Protection Partners

1412 Derwent Way
Delta BC, Canada V3M-6H9
Phone: (800) 810-1788
Email: firestop@firesstop.com

SINGLE PENETRATIONS W/ PFP PARTNERS

Horizontal (Floor/Ceiling)

Test Standards: ASTM E-814, UL 1479, ULC S115-M05

Test Furnace Internal Positive Pressure Differential – 50 Pa (0.2 in. of Water)

Penetrating Material & Size	Max. Hole Size	Annular Space	Fire "F" Rating	Fire/Hose "FH" Rating	Temp Rating "FTH" Rating
InnoFlue® SW 2"–6" (O.D.)	8" (203mm)	1/8 – 1" (3 – 25mm)	Up to 2 Hr	Up to 2 Hr	Up to 2 Hr

①	Penetrating Item	InnoFlue® SW 2" through 6" vent lengths can be Centered or offset in hole, see table above. Single penetrations only, maximum hole size not to exceed table above.
②	Floor/Wall Assembly	Code conforming 2 hour rated floor or wall assembly having a min. nominal 4 1/2" (115mm) thick lightweight or normal weight concrete or hollow-core concrete. Wall may also be constructed of nominal 8" (203mm) thick concrete blocks (filled or unfilled).
③	InnoFlue Covering Material	Friendly Feel® Duct Wrap with ECOSE® Technology, 3M™ Fire Barrier Plenum Wrap 5A+, Unifrax FyreWrap® 0.5 Plenum Insulation or equivalent fiberglass Insulation with foil – Single layer of 1/2" (12 mm) thick fiberglass insulation installed as per third party agencies Flame Spread and Smoke Development listed installation instructions. Insulation to be tightly butted to top and bottom of collar for both floor or wall assemblies. All seams longitudinal and transverse joints to be sealed with min 2 inch (51mm) wide aluminum foil tape.
④	Intumescent Strip	PFP Partners – WS1 Wrap Strip* – Nominal 1/8" (3 mm) thick intumescent material supplied in 2" (50mm) wide strips. Min 1 layer of strip to be wrapped tightly round InnoFlue and fastened in place with aluminum foil tape. Wrap strip to be flush with bottom surface of floor or both sides of the wall.
⑤	Mineral Wool Insulation	Filler material, mineral rock wool insulation with a minimum density of 4-6 PCF (68 kg/m3) compressed a minimum of 25% into the annular space at a minimum depth of 2" (51mm) on each side of the floor or wall assembly. Recess filler material 1/2" (13mm) for sealant placement, not required for wall assemblies. For walls, filler material to be flush with both sides of the assembly.
⑥	Fire Rated Sealant	PFP Partners – Firestop 3600EX*, 4100NS*, 4100SL*, or 4800DW* installed at a minimum thickness of 1/2" (13mm) within the annulus on top surface of floor assembly, not required for wall assemblies. On 0 – 1/4" (0 – 6 mm) annular spaces, a 1/2" (13 mm) diameter fillet bead must be placed around InnoFlue® Vent System.
⑦	Plastic Pipe Collar	PFP Partners – Plastic Pipe Collar* (PPC) specifically sized for diameter of InnoFlue. PPC secured to floor/ceiling assembly or wall assembly using 1/4" (6mm) diameter by 1-1/4" (32mm) long steel masonry anchors over fender washers. For walls, the system shall be symmetrical, with PPC installed on each side of the assembly and fixed in the manner as described for floor penetrations.

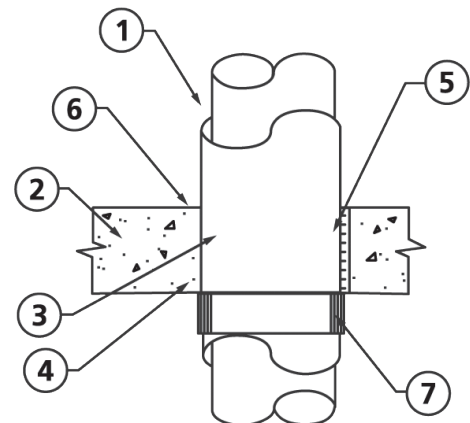
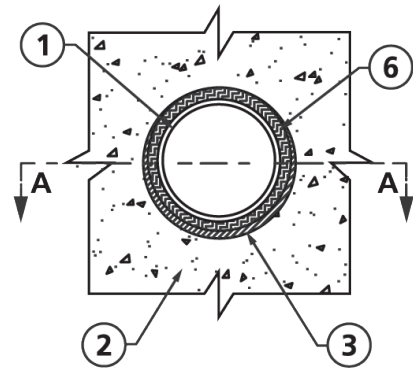

SECTION A-A

3M™:

InnoFlue® 2” through 4” diameters can be used with 3M™ Fire Protection Products to achieve 1 or 2 hr fire rating. Engineering Judgments for 2 hour fire ratings are available from 3M™ for 6” through 12” diameter InnoFlue® Single Wall Vent Systems. Contact Centrotherm or 3M™ for more information on commercial diameter fire ratings.

Ryan D. Fenstermaker
3M Building & Commercial Services /
Fire Protection Products
Mobile: 732.921.1503 | Fax: 732.432.0616
r Fenstermaker@mmm.com

SINGLE PENETRATIONS W/ 3M™

Horizontal (Floor/Ceiling)

Test Standards: ASTM E- 814, UL 1479, ULC S115-M05

Penetrating Material & Size	Max. Hole Size	Fire “F” Rating	Fire/Hose “FH” Rating	Temp Rating “FTH” Rating
InnoFlue® SW 2”–12” (O.D.)	14” (356mm)	Up to 2 Hr	Up to 2 Hr	Up to 2 Hr

①	Penetrating Item	InnoFlue® SW 2” through 12” vent lengths can be Centered or offset in hole, see table above. Single penetrations only, maximum hole size not to exceed table above.
②	Floor/Wall Assembly	Code conforming 2 hour rated floor or wall assembly of concrete or gypsum.
③	InnoFlue Covering Material	3M™ Fire Barrier Plenum Wrap 5A+ – Single layer of 1/2” (12 mm) thick fiberglass insulation installed per third party agencies Flame Spread and Smoke Development listed installation instructions. Insulation to be tightly butted to top and bottom of collar for both floor or wall assemblies. All seams longitudinal and transverse joints to be sealed with min 2 in. (51mm) wide aluminum foil tape.
④	Intumescent Strip	3M™ – FS-195+ Wrap Strips: Tightly wrap the proper number of FS-195+ Wrap Strips around InnoFlue foil side out. Secure with tape or tie wire. Make sure FS-195+ Wrap Strip or PPD butts securely against the concrete with a 3/16” minimum overlap over the edge of the penetrating opening. When using more than one wrap, stagger the butted seams.
⑤	Plastic Pipe Collar	3M™ – RC-1 Restricting Collar: Remove enough RC-1 Restricting Collar to make one wrap around the applied FS-195+ Wrap Strip with a minimum 1” overlap. Bend the mounting tabs away from the pipe at right angles, flush with the bottom floor surface. Warning: Edges of RC-1 Restricting Collar are sharp. Handle with care. Tightly secure the RC-1 Restricting Collar around the pipe with a steel hose clamp centered on the RC-1 Restricting Collar assembly. Two bands of 16 gauge steel tie wire placed ½ from the ends of the RC-1 Restricting Collar assembly may be used instead of the hose clamp. Secure the collar to the slab with ¼” x 1 ½” masonry fasteners. Use 1 ¼” diameter fender washers on the mounting tabs.
⑥	Fire Rated Sealant	3M™ – CP 25WB+ Caulk: Seal the system with ¼” bead of 3M™ Fire Barrier CP 25WB+ Caulk or Moldable Putty+ at the concrete and collar assembly interface.

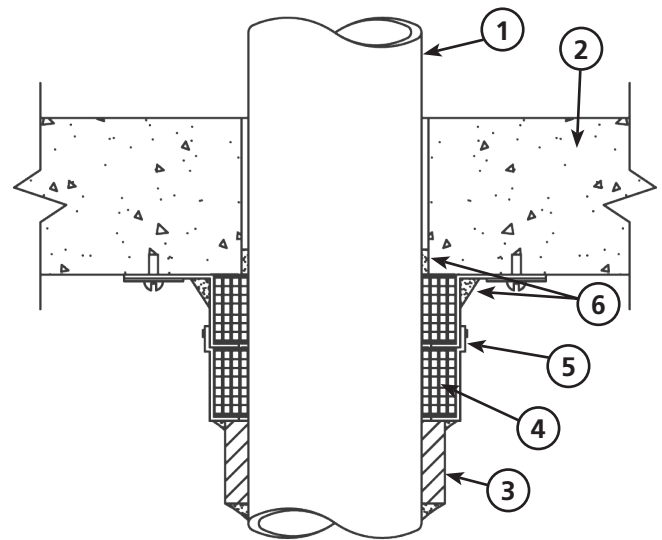

Installation Instructions

BASIC CONCENTRIC INSTALLATION INSTRUCTIONS

Joint connection

- Vent connections must be firmly pressed together so that the gaskets form an airtight seal.
- To ensure optimum joint connection, secure with two #8 x 1/2" self tapping screws provided. Screw through pre-drilled holes in metal female socket.
- Secure the vent to the wall or ceiling with pipe clamps or perforated hanger iron.

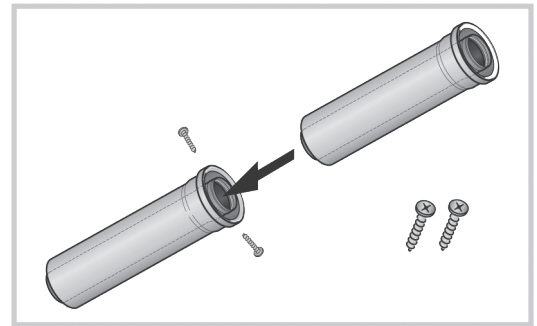

Condensation Management

- Horizontal vent lengths must pitch a minimum 5/8" /ft. (3° or 55 mm/m) to the appliance.

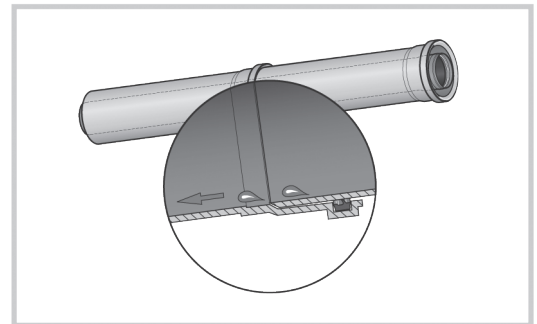

NOTE

See exception under Condensate on page 4.

Appliance connection (female appliance top)

- Insert the male end of a vent component into the female appliance top.

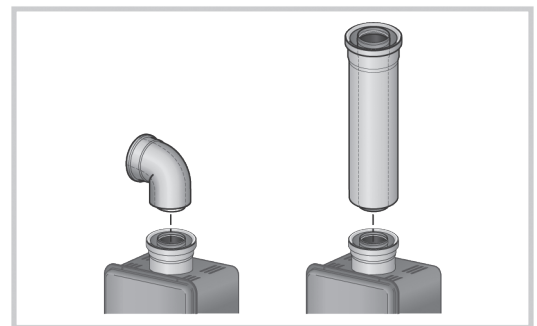

NOTE

Certain appliances may require an appliance adapter

Shortening of vent extensions

- The inside pipe should always extend 0.4" (10 mm) beyond the white outside pipe on the male end of the vent extension.
- Always cut the male end of the vent pipe extension. Do not attempt to cut the female end.
- When cutting to size outer vent lengths overlap by 1.25" (37mm).
- Deburr both air intake (outer) and exhaust (inner). Failure to do so may result in gasket damage.

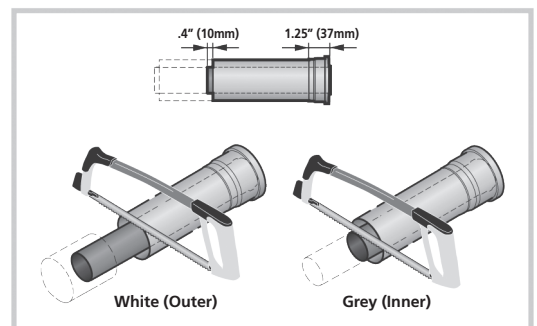

⚠ WARNING

Improper installation of vent system and components, or failure to follow all installation instructions, can result in property damage or serious injury.

HORIZONTAL CONCENTRIC VENT SYSTEM

Identify the Vent Location

- Place the 87° Vent Pipe Elbow on the appliance.
- Mark position on wall taking into account 3° pitch.
- Or use template provided with appliance.
- Cut hole, covering the top of the appliance to prevent debris from entering.

Measure Dimension to Fit

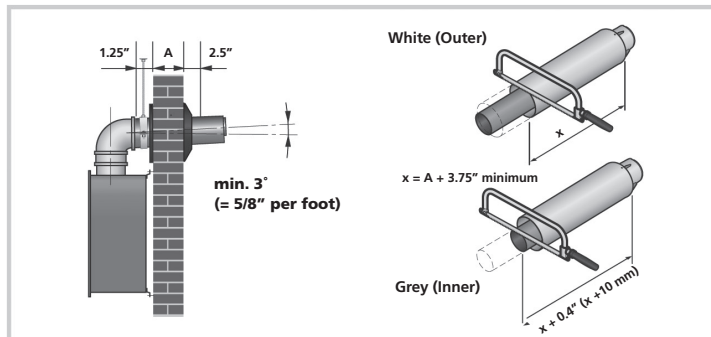

Reference page 5 of these installation instructions for the acceptable pitch direction.

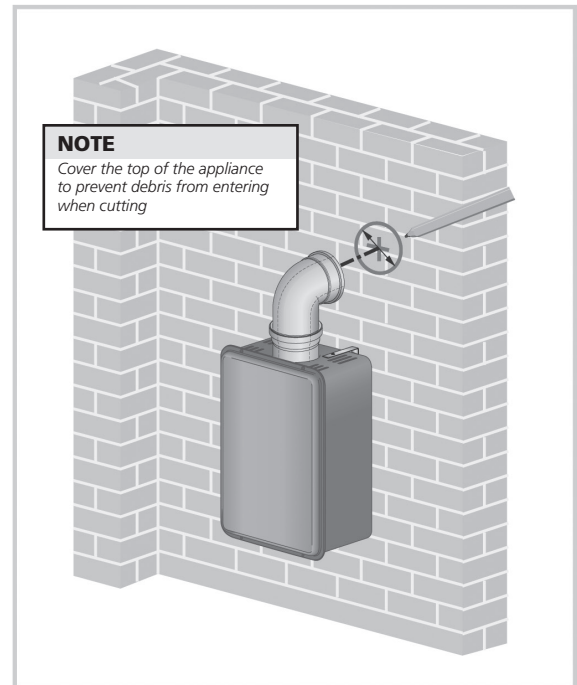

Final Installation of the Vent System

- After cutting the appropriate length, position the Wall Plate (A) and slide the Horizontal Termination through the hole in the wall. Position the Wall Plate around the male end of the Termination.
- Slide the male end of the Termination into the 87° Vent Pipe Elbow.
- Secure the system with the supplied Termination Support Clamp.
- Fill the gaps between the wall and the vent.

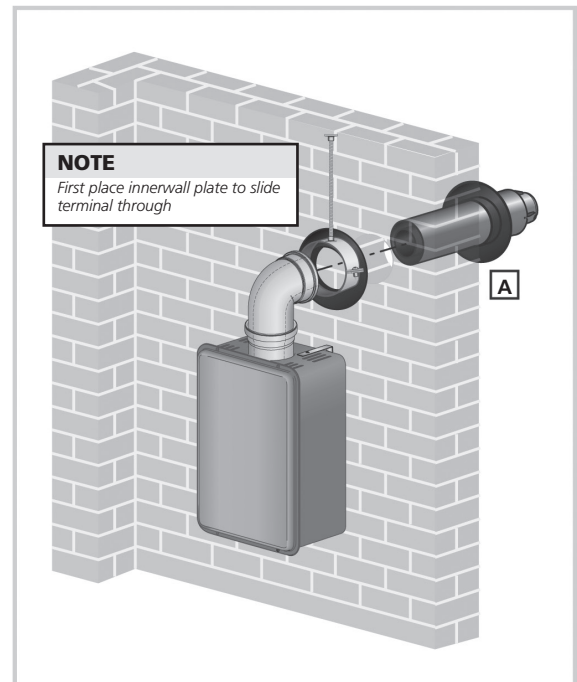

Installation Instructions

VERTICAL CONCENTRIC VENT SYSTEM

Identify the vent location

- Determine the location where the roof discharge terminal will be installed.
- Taking into account the angle of the roof, cut the hole with a dimension that allows the vertical discharge roof terminal to be installed.

Cut to Fit

- The terminal can be shortened by cutting both the inside and outside pipes. See basic Concentric installation instructions for shortening.
- Deburr both air intake (outer) and exhaust (inner). Failure to do so may result in gasket damage.

Mounting the vent system

- Vent connections must be firmly pressed together so that the gaskets form an air tight seal.
- Secure the system with the supplied Termination Support Clamp.

