

## VR8300A,C Continuous Pilot Combination Gas Control

### Application

These continuous pilot gas controls are used in gas-fired appliances with capacities up to 200 feet<sup>3</sup>/hour at 1 inch wc pressure drop [5.7 meters<sup>3</sup>/hour at 0.25 kPa] on natural gas. They include a manual valve, safety shutoff, two automatic operators, and a pressure regulator. See Table 1 for temperature range and regulator type.

The VR8300 setup for natural gas includes a 393691 LP Conversion Kit. The kit contains a cap screw, a pressure

regulator adjustment screw, a tapered spring and a conversion label.

**BODY PATTERN:** Straight-through body pattern.

**INLET X OUTLET SIZES AVAILABLE:** 1/2 x 1/2 inch, 1/2 x 3/4 inch, and 3/4 x 3/4 inch (factory-installed inlet flange).

**ADAPTERS:** Adapters available for 1/2 and 3/4 inch straight and angle connections. Refer to Table 2.

**ELECTRICAL RATINGS:**

**VOLTAGE AND FREQUENCY:** 24 Vac, 50/60 Hz.

**CURRENT DRAW:** 0.70A.

### CAPACITY:

Size (Inlet x Outlet)	Capacity at 1 inch wc Pressure Drop <sup>a</sup>	Minimum Regulated Capacity	Maximum Regulated Capacity
1/2 x 1/2	180 feet <sup>3</sup> /hour [5.1 meter <sup>3</sup> /hour]	30 feet <sup>3</sup> /hour [0.8 meter <sup>3</sup> /hour]	225 feet <sup>3</sup> /hour [6.4 meter <sup>3</sup> /hour]
1/2 x 3/4	190 feet <sup>3</sup> /hour [5.4 meter <sup>3</sup> /hour]	30 feet <sup>3</sup> /hour [0.8 meter <sup>3</sup> /hour]	290 feet <sup>3</sup> /hour [8.2 meter <sup>3</sup> /hour]
3/4 x 3/4	200 feet <sup>3</sup> /hour [5.7 meter <sup>3</sup> /hour]	30 feet <sup>3</sup> /hour [0.8 meter <sup>3</sup> /hour]	300 feet <sup>3</sup> /hour [8.5 meter <sup>3</sup> /hour]

<sup>a</sup>Capacity based on 1000 Btu/feet<sup>3</sup>, 0.64 specific gravity natural gas at 1 inch wc pressure drop [37.3 MJ/meter<sup>3</sup>, 0.64 specific gravity natural gas at 0.25 kPa pressure drop].

Use conversion factors in Table 3 to convert capacities for other gases.

TABLE 1—TEMPERATURE RANGE AND  
REGULATOR TYPE.

Model Number	Ambient Temperature Range	Regulator Type
VR8300A	0° F to 175° F [-18° C to +79° C]	Standard-opening
VR8300C	0° F to 175° F [-18° C to +79° C]	Step-opening

TABLE 2—3-ADAPTER (FLANGE)  
PART NUMBERS.

Inlet/ Outlet Pipe Size	Flange Type	Part Number	
		Without Hex Wrench	With Hex Wrench
1/2 inch NPT	Straight	394599-6	393690-16
	Elbow	394599-3	393690-13
3/4 inch NPT	Straight	394599-4	393690-14
	Elbow	394599-5	393690-15

NOTE: Flange kits include one flange with attached O-ring and four mounting screws.

TABLE 3—GAS CAPACITY  
CONVERSION FACTORS.

Gas	Specific Gravity	Multiple Listed Capacity By
Manufactured	0.60	0.516
Mixed	0.70	0.765
Propane	1.53	1.62

**APPROVALS:**

AMERICAN GAS ASSOCIATION DESIGN CERTIFICATE: UP-70-69A.

CANADIAN GAS ASSOCIATION DESIGN CERTIFICATE: UP-70-69A.

AUSTRALIAN GAS ASSOCIATION DESIGN CERTIFICATE: Applied for.

DELTA C: Applied for.

## Installation

### WHEN INSTALLING THIS PRODUCT...

1. Read these instructions carefully. Failure to follow them could damage the product or cause a hazardous condition.
2. Check the ratings given in the instructions and on the product to ensure the product is suitable for your application.
3. Ensure installer is a trained, experienced service technician.
4. After installation is complete, use these instructions to check out product operation.



## WARNING

**FIRE OR EXPLOSION HAZARD  
CAN CAUSE PROPERTY DAMAGE,  
SEVERE INJURY, OR DEATH**

### Follow these warnings exactly.

1. Disconnect power supply before wiring to prevent electrical shock or equipment damage.
2. To avoid dangerous accumulation of fuel gas, turn off gas supply at the appliance service valve before starting installation, and perform Gas Leak Test after completion of installation.
3. Do not bend pilot tubing at gas control or pilot burner after compression fitting has been tightened, or gas leakage at the connection may result.
4. Always install sediment trap in gas supply line to prevent contamination of gas control.
5. Do not force the gas control knob. Use only your hand to push down the reset button or turn the gas control knob. Never use any tools. If the gas control knob or reset button will not operate by hand, the gas control should be replaced by a qualified service technician. Force or attempted repair may result in fire or explosion.



## CAUTION

Never apply a jumper across or short the valve coil terminals. This may burn out the heat anticipator in the thermostat.

**IMPORTANT:** These gas controls are shipped with protective seals over inlet and outlet tappings. Do not remove seals until ready to connect piping.

Follow the appliance manufacturer's instructions if available; otherwise, use the instructions provided below.

## CONVERTING BETWEEN NATURAL AND LP GAS



## WARNING

**FIRE OR EXPLOSION HAZARD  
CAN CAUSE PROPERTY DAMAGE,  
SEVERE INJURY, OR DEATH**

1. Do not use a gas control set for natural gas on LP gas or a gas control set for LP gas on natural gas.
2. When making conversion, main and pilot burner orifices **MUST** be changed to meet appliance manufacturer specifications.

VR8300A gas controls may be converted from one gas to another. To convert from natural gas to LP, use the 393691 LP Conversion Kit that is included with the VR8300A gas control. To convert from LP to natural gas, use the 394588 Natural Gas Conversion Kit (order separately). VR8300C gas controls cannot be converted.

To convert control from one gas to another:

1. Turn off main gas supply to the appliance.
2. Remove the regulator cap screw and pressure regulator adjusting screw. See Fig. 1.

Fig. 1—Top view of gas control.

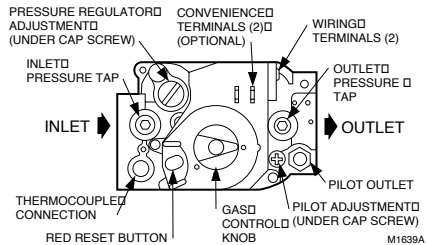

3. Remove the existing spring.
4. Insert the replacement spring with tapered end down. See Fig. 2.

5. Install the new plastic pressure regulator adjustment screw so that the top of the screw is flush (level) with the top of the regulator. Turn the pressure regulator adjustment screw clockwise  six complete turns. This provides preliminary pressure setting of about 10.0 in. wc [2.5 kPa] for LP regulator and 3.5 in. wc [0.9 kPa] for natural gas regulator.

6. Check the regulator setting either with a manometer or by clocking the gas meter. Refer to Start-Up and Checkout, page 4.

7. Install the new cap screw.
8. Mount conversion label on control.
9. Install control and appliance according to appliance manufacturer's instructions.

**Fig. 2—Installation of conversion kit in regulated gas control.**

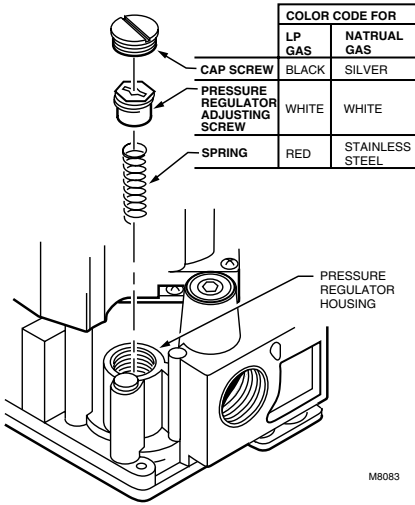

### INSTALL BUSHINGS TO CONTROL

If adapters are to be installed on the gas control, mount them as follows:

#### Bushings:

1. Remove seal over gas control inlet or outlet.
2. Apply moderate amount of good quality pipe compound to bushing, leaving two end threads bare. On LP installation, use compound resistant to LP gas. Do NOT use Teflon tape.
3. Insert bushing in gas control and thread pipe carefully into bushing until tight.

Complete instructions below for piping, installing control, connecting pilot tubing, thermocouple and wiring. Make certain the leak test you perform on the control after completing the installation includes leak testing the adapters and screws. If you use a wrench on the valve after flanges are installed, use the wrench only on the flange, not on the control.

### USING ADAPTERS TO SOLVE SWING RADIUS PROBLEMS

In some field service applications, it is difficult or impossible to thread the gas control onto the gas supply pipe because of space limitations. This problem can be resolved in many instances by using an adapter. The adapter is installed on the end of the supply pipe in place of the gas control, following the same precautions and instructions that are used for installing the gas control. After the adapter is installed, the gas control is attached to the adapter as outlined above. Note that using an adapter increases the overall length of the gas control.

### CHOOSE GAS CONTROL LOCATION

Do not locate the gas control where it may be affected by steam cleaning, high humidity, dripping water, corrosive

chemicals, dust or grease accumulation, or excessive heat. To ensure proper operation, follow these guidelines:

- Locate gas control in a well ventilated area.
- Mount gas control high enough above the cabinet bottom to avoid exposure to flooding or splashing water.
- Ensure the ambient temperature does not exceed the ambient temperature ratings for each component.
- Cover gas control if appliance is cleaned with water, steam, or chemicals or to avoid dust and grease accumulation.
- Avoid locating gas control near possible exposure to corrosive chemical fumes or dripping water.

Locate the gas control in the appliance vestibule on the gas manifold. In replacement applications, locate the gas control in the same location as the old gas control.

### Install Piping to Gas Control

All piping must comply with local codes and ordinances or with the National Fuel Gas Code (ANSI Z223.1 NFPA No. 54), whichever applies. Tubing installation must comply with approved standards and practices.

1. Use new, properly reamed pipe free from chips. If tubing is used, ensure the ends are square, deburred and clean. All tubing bends must be smooth and without deformation.
2. Run pipe or tubing to the gas control. If tubing is used, obtain a tube-to-pipe coupling to connect the tubing to the gas control.
3. Install sediment trap in the supply line to the gas control. See Fig. 3.

### Install Gas Control

**Fig. 3—Sediment trap installation.**

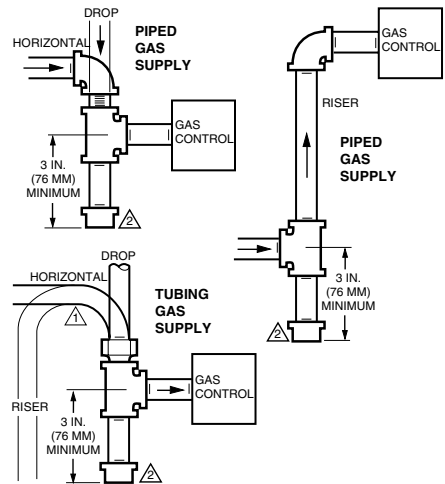

- ⚠ ALL BENDS IN METALLIC TUBING SHOULD BE SMOOTH.
- ⚠ CAUTION: SHUT OFF THE MAIN GAS SUPPLY BEFORE REMOVING END CAP TO PREVENT GAS FROM FILLING THE WORK AREA. TEST FOR GAS LEAKAGE WHEN INSTALLATION IS COMPLETE. M3077

**Fig. 4—Use moderate amount of pipe compound.**

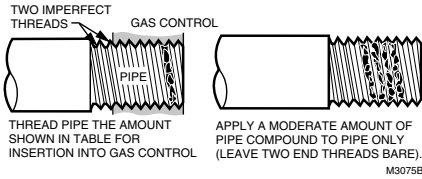

1. Mount the gas control 0-90 degrees, in any direction including vertically, from the upright position of the gas control knob.

2. Mount the gas control so gas flow is in the direction of the arrow on the bottom of the gas control.

3. Thread pipe the amount shown in Table 4 for insertion into gas control. **DO NOT THREAD PIPE TOO FAR.** Valve distortion or malfunction may result if the pipe is inserted too deeply into the gas control. Refer to Fig. 4.

**TABLE 4—NPT PIPE THREAD LENGTH IN INCHES.**

Pipe Size	Thread Pipe This Amount	Maximum Depth Pipe Can Be Inserted Into Control
3/8	9/16	3/8
1/2	3/4	1/2
3/4	13/16	3/4

4. Apply a moderate amount of good quality pipe compound (DO NOT use Teflon tape) to pipe only, leaving two end threads bare. On LP installations, use compound resistant to LP gas.

5. Remove seals over gas control inlet and outlet if necessary.

6. Connect pipe to gas control inlet and outlet. Use wrench on the square ends of the gas control. If an adapter is used, place wrench on adapter rather than gas control. Refer to Figs. 1 and 5.

**Fig. 5—Proper use of wrench on gas control.**

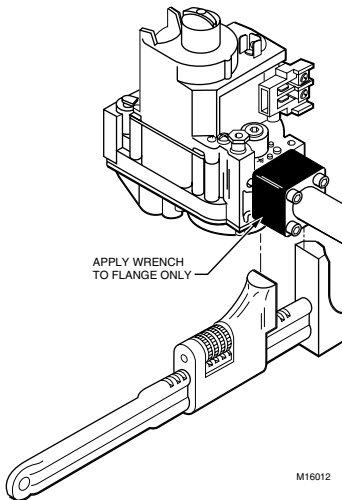

**Connect Pilot Gas Tubing**

1. Cut tubing to desired length and bend as necessary for routing to pilot burner. Do not make sharp bends or deform the tubing. Do not bend tubing at gas control or pilot burner after compression fitting has been tightened, as this may result in gas leakage at the connection.

2. Square off and remove burrs from end of tubing.

3. Unscrew compression fitting from the pilot outlet (Fig. 1).

1). Slip the compression fitting over the tubing and slide out of the way.

**NOTE:** When replacing a gas control, cut off old compression fitting and replace with the new compression fitting provided on the gas control. Never use the old compression fitting as it may not provide a gas-tight seal.

4. Push tubing into the pilot gas tapping on the outlet end of the control until it bottoms. While holding tubing all the way in, slide compression fitting into place and engage threads—turn until finger tight. Then tighten one more turn with wrench. Do not overtighten. Refer to Fig. 6.

5. Connect other end of tubing to pilot burner according to pilot burner manufacturer's instructions.

**Fig. 6—Always use new compression fitting.**

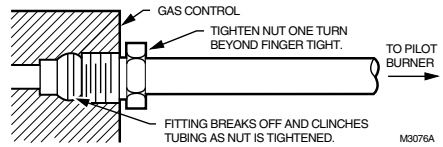

**Fig. 7—Installing thermocouple and optional ECO connector to the power unit.**

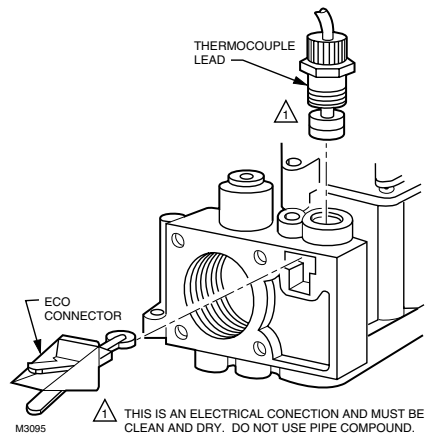

TABLE 5—MAXIMUM LENGTH OF SUPPLEMENTARY LIMIT LEADWIRES  
WHEN USING Q340A THERMOCOUPLE.

Thermocouple Length		Maximum Leadwire Length x 2 (wires)					
		AWG No. 14		AWG No. 16		AWG No. 18	
inches	meters	inches	meters	inches	meters	inches	meters
18	0.5	35	0.9	22	0.6	13	0.3
24	0.6	29	0.7	18	0.5	11	0.3
30	0.8	23	0.6	15	0.4	9	0.2
36	0.9	17	0.4	11	0.3	6	0.2
48	1.2	DO NOT USE.					
60	1.5						

TABLE 6—MAXIMUM LENGTH OF SUPPLEMENTARY LIMIT LEADWIRES  
WHEN USING Q309/Q390 THERMOCOUPLE.

Thermocouple Length		Maximum Leadwire Length x 2 (wires)					
		AWG No. 14		AWG No. 16		AWG No. 18	
inches	meters	inches	meters	inches	meters	inches	meters
12	0.3	47	1.2	30	0.8	18	0.5
18	0.5	41	1.0	26	0.7	16	0.4
24	0.6	35	0.9	22	0.6	14	0.4
30	0.8	29	0.8	18	0.5	11	0.3
36	0.9	23	0.6	15	0.4	9	0.2
40	1.0	19	0.5	12	0.3	7	0.2
48	1.2	11	0.3	7	0.2	DO NOT USE.	
60	1.5						

### Connect Thermocouple

If a supplementary limit or energy cutoff (ECO) is used, insert the ECO connector (order part no. 394332) as shown in Fig. 7, and then connect thermocouple lead. Otherwise, insert thermocouple lead directly. This is an electrical connection and must be clean and dry. Never use pipe compound. Tighten only 1/4 turn beyond finger tight to give good electrical continuity. **DO NOT OVERTIGHTEN.**

Fig. 8—Wiring connections for 24 volt control.

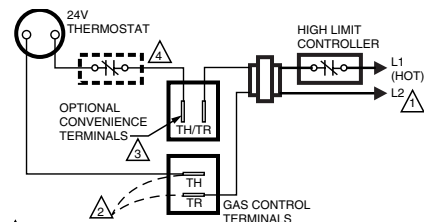

- ⚠ POWER SUPPLY. PROVIDE DISCONNECT MEANS AND OVERLOAD PROTECTION AS REQUIRED.
  - ⚠ DO NOT JUMPER THESE TERMINALS. THIS SHORTS VALVE COIL AND CAN BURN OUT ANTICIPATOR IN THERMOSTAT.
  - ⚠ CONVENIENCE TERMINALS SERVE ONLY AS A TIE POINT. THEY ARE NOT INTERNALLY WIRED TO THE CONTROL CIRCUIT OR TO GROUND.
  - ⚠ OPTIONAL HIGH LIMIT.
- M2915

### WIRING

Follow the wiring instructions furnished by the appliance manufacturer, if available, or use the general instructions provided below. Refer to Table 5 or 6

All wiring must comply with applicable electrical codes and ordinances.

Disconnect power supply before making wiring connections to prevent electrical shock or equipment damage.

1. Check the power supply rating on the gas control and ensure it matches the available supply. Install transformer, thermostat, and other controls as required.

2. Connect control circuit to gas control terminals. See Figs. 1 and 8.

3. Adjust thermostat heat anticipator to 0.70 rating stamped on valve operator.

## Start-Up and Checkout



### WARNING

**FIRE OR EXPLOSION HAZARD  
CAN CAUSE PROPERTY DAMAGE,  
SEVERE INJURY, OR DEATH**

1. Do not force the gas control knob. Use only your hand to push down the reset button or turn the gas control knob. Never use any tools.
2. If the gas control knob or reset button will not operate by hand, or if the reset button stays depressed after it is released, the gas control should be replaced by a qualified service technician.

## GAS CONTROL KNOB SETTINGS

The gas control knob has three settings:

**OFF**—prevents pilot and main burner gas flow.

**PILOT**—permits pilot gas flow only. Gas control knob must be held depressed or thermocouple must be heated sufficiently to hold the safety control valve open.

**ON**—permits main burner and pilot gas flow. Thermostat and gas control control main burner gas flow.

**NOTE:** Gas controls are shipped with the gas control knob in the ON position.

## PERFORM GAS LEAK TEST



### WARNING

**FIRE OR EXPLOSION HAZARD  
CAN CAUSE PROPERTY DAMAGE,  
SEVERE INJURY, OR DEATH**

Check for gas leaks with rich soap and water solution any time work is done on a gas control.

## GAS LEAK TEST

1. Paint all pipe connections upstream of the gas control with a rich soap and water solution. Bubbles indicate a gas leak.

2. If a gas leak is detected, tighten the pipe connection.

3. Stand clear while lighting main burner to prevent injury caused from hidden gas leaks which could cause flashback in the appliance vestibule. Light the main burner.

4. With the main burner in operation, paint all pipe joints (including adapters) and gas control inlet and outlet with rich soap and water solution.

5. If another gas leak is detected, tighten adapter screws, joints, and pipe connections.



6. Replace the part if gas leak cannot be stopped.

## LIGHT THE PILOT BURNER FLAME

1. Turn the gas control knob clockwise  to **OFF**. Wait five minutes to dissipate any unburned gas. Sniff around the appliance near the floor. Do not relight the pilot flame if you smell gas.

2. Turn the gas control knob counterclockwise  to **PILOT**. Push down and hold the gas control knob while lighting the pilot flame.



3. Hold the gas control knob down about one minute, then release.

- If the pilot flame goes out, turn the gas control knob clockwise  to **OFF** and repeat steps 1 through 3.
- If pilot flame remains lit, turn the gas control knob counterclockwise  to **ON**.

## ADJUST THE PILOT BURNER FLAME

The pilot flame should envelop 3/8 to 1/2 inch [10 to 13 millimeters] of the thermocouple tip. Refer to Fig. 9. To adjust the pilot flame:

1. Remove the pilot adjustment cover screw. Refer to Fig.

1. Turn the inner adjustment screw clockwise  to decrease or counterclockwise  to increase the pilot flame.

**Fig. 9—Proper flame adjustment.**

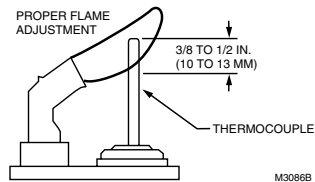

3. Always replace the cover screw after adjustment and tighten firmly to ensure proper operation.

## LIGHT MAIN BURNER

Follow the appliance manufacturer's instructions or set the thermostat setting above room temperature to call for heat.

## CHECK AND ADJUST GAS INPUT TO MAIN BURNER



### CAUTION

1. Do not exceed the input rating stamped on the appliance nameplate, or manufacturer's recommended burner orifice pressure for the size orifice used. Ensure the main burner primary air supply is properly adjusted for complete combustion (refer to the appliance manufacturer's instructions).

2. **IF CHECKING GAS INPUT BY CLOCKING THE GAS METER:**

- Ensure that the only gas flow through the meter is that of the appliance being tested.
- Ensure that other appliances are turned off and that their pilot burners are extinguished (or deduct their gas consumptions from the meter reading).
- Convert the flow rate to Btuh as described in the Gas Controls Handbook (form number 70-2602) and compare to the Btuh input rating on the appliance nameplate.

3. **IF CHECKING GAS INPUT WITH A MANOMETER (PRESSURE GAUGE):**

- Ensure the gas control knob is in the **PILOT** position before removing the outlet pressure tap plug to connect the manometer.
- Turn the gas control knob back to **PILOT** when removing the manometer and replacing outlet pressure tap plug.
- Shut off the gas supply at the appliance service valve or, for LP gas, at the gas tank before removing outlet the pressure tap plug and before disconnecting the manometer and replacing the outlet pressure tap plug.
- Perform the Gas Leak Test at the inlet pressure tap plug.

TABLE 7—PRESSURE REGULATOR SPECIFICATION PRESSURES IN INCHES WC.

Model	Type of Gas	Nominal Inlet Pressure Range	Outlet Pressure			
			Nominal Factory Setting		Setting Range	
			Step	Full Rate	Step	Full Rate
Standard-, Slow-opening	NATURAL	5.0 - 7.0	—	3.5	—	3.0 - 5.0
	LP	12.0 - 14.0	—	10.0	—	8.0 - 12.0
Step-opening	NATURAL	5.0 - 7.0	0.9	3.5	—	3.0 - 5.0
	LP	12.0 - 14.0	2.2	10.0	—	8.0 - 12.0

TABLE 8—PRESSURE REGULATOR SPECIFICATION PRESSURES IN kPa.

Model	Type of Gas	Nominal Inlet Pressure Range	Outlet Pressure			
			Nominal Factory Setting		Setting Range	
			Step	Full Rate	Step	Full Rate
Standard-, Slow-opening	NATURAL	1.2 - 1.7	—	0.9	—	0.7 - 1.2
	LP	2.9 - 3.9	—	2.7	—	2.0 - 3.0
Step-opening	NATURAL	1.2 - 1.7	0.2	0.9	—	0.7 - 1.2
	LP	2.9 - 3.9	0.9	2.7	—	2.0 - 3.0



### Standard-Opening and Slow-Opening Pressure Regulator

1. The gas control outlet pressure should match the manifold pressure listed on the appliance nameplate.

2. With the main burner operating, check the gas control flow rate using the meter clocking method or check the gas pressure using a manometer connected to the gas control outlet pressure tap. Refer to Fig. 1.

3. If necessary, adjust the pressure regulator to match the appliance rating. Refer to Table 7 or 8 for the factory set nominal outlet pressures and adjustment ranges.

a. Remove the pressure regulator adjustment cap and screw.

b. Using a screwdriver, turn the inner adjustment screw clockwise  to increase or counterclockwise  to decrease the main burner gas pressure.

c. Always replace the cap screw and tighten firmly to ensure proper operation.

4. If the desired outlet gas pressure or gas flow rate cannot be achieved by adjusting the gas control, check the gas control inlet pressure using a manometer at the inlet pressure tap. If the inlet pressure is in the normal range (refer to Table 7 or 8), replace the gas control. Otherwise, take the necessary steps to provide proper gas pressure to the gas control.

### Step-Opening Pressure Regulator

1. The gas control outlet pressure should match the manifold pressure listed on the appliance nameplate.

2. With main burner operating, check the gas control flow rate using the meter clocking method or check the gas pressure using a manometer connected to the gas control outlet pressure tap. Refer to Fig. 1.

3. If necessary, adjust the pressure regulator to match the appliance rating. Refer to Table 7 or 8 for factory set nominal outlet pressures and adjustment ranges.

a. Remove the pressure regulator adjustment cap screw.

b. Using a screwdriver, turn the inner adjustment screw clockwise  to increase or

counterclockwise  to decrease the main burner gas pressure.

c. Always replace the cap screw and tighten firmly to ensure proper operation.

4. If desired outlet pressure or flow rate cannot be achieved by adjusting the gas control, check the inlet pressure using a manometer at inlet pressure tap or upstream of the gas control. If the inlet pressure is in the normal range (refer to Table 7 or 8), replace the existing gas control. Otherwise, take the necessary steps to provide proper gas pressure to the gas control.

5. Carefully check main burner lightoff at the step pressure. Ensure the main burner lights smoothly and without flashback to the orifice and that all ports remain lit. Cycle the main burner several times, allowing at least 30 seconds between cycles for the regulator to resume the step function. Repeat after allowing main burner to cool. Readjust the full rate outlet pressure if necessary to improve lightoff characteristics.

### CHECK SAFETY SHUTDOWN PERFORMANCE



## WARNING

**FIRE OR EXPLOSION HAZARD  
CAN CAUSE PROPERTY DAMAGE,  
SEVERE INJURY, OR DEATH**

Perform the safety shutdown test any time work is done on a gas system.

1. Place gas control knob in PILOT position. Main burner should go off and pilot should remain lit.

2. Extinguish pilot flame. Pilot gas flow should stop within 2-1/2 minutes. Safety shutoff of pilot gas proves complete shutdown since safety shutoff valve prevents main burner and pilot gas flow.

3. Relight pilot burner and operate system through one complete cycle to ensure all controls operate properly.

## Maintenance



### WARNING

#### **FIRE OR EXPLOSION HAZARD CAN CAUSE PROPERTY DAMAGE, SEVERE INJURY, OR DEATH**

Improper cleaning or reassembly may cause gas leakage. When cleaning, ensure that control is reassembled properly and perform gas leak test.

Regular preventive maintenance is important in applications that place a heavy load on system controls, such as in the commercial cooking and agricultural and industrial industries because:

- The equipment operates 100,000-200,000 cycles per year in many such applications, particularly commercial cooking. Such heavy cycling can wear out the gas control in one to two years.
- Exposure to water, dirt, chemicals and heat can damage the gas control and shut down the control system. The maintenance program should include regular checkout of the gas control, see Start-Up and Checkout, page 0, and the control system, see the appliance manufacturer's literature.

Maintenance frequency must be determined individually for each application. Some considerations are:

- **Cycling frequency.** Appliances that may cycle 100,000 times annually should be checked monthly.
- **Intermittent use.** Appliances that are used seasonally should be checked before shutdown and again before the next use.
- **Consequence of unexpected shutdown.** Where the cost of an unexpected shutdown would be high, the system should be checked more often.
- **Dusty, wet, or corrosive environment.** Since these environments can cause the gas control to deteriorate more rapidly, the system should be checked more often.

The gas control should be replaced if:

- It does not perform properly on checkout or troubleshooting.
- The gas control knob is hard to turn or push down, or it fails to pop back up when released.
- The gas control is likely to have operated for more than 200,000 cycles.

## Service



### WARNING

#### **FIRE OR EXPLOSION HAZARD CAN CAUSE PROPERTY DAMAGE, SEVERE INJURY OR DEATH**

Do not disassemble the gas control; it contains no replaceable components. Attempted disassembly or repair may damage the gas control.



### CAUTION

Do not apply a jumper across or short the valve coil terminals. This may burn out the heat anticipator in the thermostat.

**IMPORTANT:** Allow 60 seconds after shutdown before re-energizing step-opening model to ensure lightoff at step pressure.

#### **IF THE PILOT BURNER FLAME WILL NOT LIGHT**

1. Ensure the main gas supply valve is open and the pilot gas supply line is purged of air.
2. Attempt to light pilot burner flame following procedures in Light the Pilot Burner Flame, page 0. If pilot burner flame still will not light:
  - a. Check the pilot gas adjustment screw. If closed, readjust the pilot flame. Refer to Adjust the Pilot Burner Flame, page 0.
  - b. Perform the Gas Leak Test at the compression fitting. If a gas leak is detected, replace the old compression fitting or tighten the newly installed one. Refer to Fig. 1.
  - c. Ensure that the pilot burner tubing or pilot burner orifice is not clogged.

#### **IF THE PILOT BURNER FLAME GOES OUT WHEN THE GAS CONTROL KNOB IS RELEASED**

1. Ensure the gas control knob is held in at least one minute to allow the thermocouple time to heat.
2. Check the pilot burner flame adjustment. Refer to Adjust the Pilot Burner Flame, page 0.
3. Check the wiring between the thermocouple and the gas control valve operator.
4. Ensure thermocouple connection to the power unit is tightened 1/4 turn beyond finger tight.
5. If pilot burner flame still goes out, measure the open and closed thermocouple output voltage. Compare it to the acceptable range charts in the thermocouple specifications or in the Gas Controls Handbook. Replace the thermocouple if voltages are outside the acceptable range.
6. Check the power unit resistance. If higher than 11 ohms, replace the gas control.

#### **IF THE MAIN BURNER WILL NOT COME ON WITH A CALL FOR HEAT**

1. Ensure the gas control knob is in the ON position.
2. Adjust the thermostat several degrees above room temperature.
3. Use an ac voltmeter to measure the voltage across terminals TH and TR. If:
  - a. no voltage is present, check the control circuit for proper operation.
  - b. 24 Vac is present, but first operator did not click open, check for excessive inlet gas pressure. If inlet gas pressure is correct, replace the gas control.
4. Measure the open and closed thermocouple output voltages and compare to the acceptable range charts in the thermocouple specifications or in the Gas Controls Handbook. Replace the thermocouple if voltages are outside the acceptable range.
5. Measure the open and closed thermocouple output voltages and compare to the acceptable range charts in the thermocouple specifications or in the Gas Controls Hand-



book. Replace the thermocouple if voltages are outside the acceptable range.

### IF THE MAIN BURNER IS OVERFIRING

Adjust the gas control pressure regulator to the correct pressure. If the regulator cannot be adjusted and supply pressure is in the normal range, replace the gas control.

### INSTRUCTIONS TO THE HOMEOWNER



## WARNING

### FIRE OR EXPLOSION HAZARD CAN CAUSE PROPERTY DAMAGE, SEVERE INJURY, OR DEATH

Follow these warnings exactly:

1. Pilot burner flame must be lit manually. Follow these instructions exactly.
2. Before lighting pilot burner flame, smell around the appliance for gas. Be sure to smell next to floor because LP gas is heavier than air.
3. IF YOU SMELL GAS:
  - Turn off the gas supply at the appliance service valve. On LP gas systems, turn off gas supply at the gas tank.
  - Do not light any appliances in the house.
  - Do not touch electrical switches or use the phone.
  - Leave the building and use a neighbor's phone to call your gas supplier.
  - If you can not reach your gas supplier, call the fire department.
4. Do not force the gas control knob. Use only your hand to push down or turn the gas control knob. Never use any tools. If the gas control knob will not operate by hand, the gas control should be replaced by a qualified service technician. Force or attempted repair may result in a fire or explosion.
5. The gas control must be replaced in case of any physical damage, tampering, bent terminals, missing or broken parts, stripped threads, or evidence of exposure to heat.

**IMPORTANT:** *Follow the operating instructions provided by the manufacturer of your heating appliance. The information below will be of assistance in a typical gas control application, but the specific controls used and the procedures outlined by the manufacturer or your appliance may differ, requiring special instructions.*



### LIGHTING THE PILOT BURNER FLAME

#### STOP: READ THE WARNINGS ABOVE.

The pilot burner flame must be lit manually. If the pilot burner flame has gone out, follow these instructions exactly.

1. Set the thermostat to its lowest setting.
2. Disconnect all electric power to the appliance.
3. Remove the gas control access panel.
4. Push in the gas control knob slightly and turn clockwise  to OFF.

NOTE: The gas control knob can not be turned from PILOT to OFF unless it is pushed in slightly. Do not force the gas control knob.

5. Wait five minutes to clear out any unburned gas. If you then smell gas, STOP! Follow item 3 in the Warnings, page 9. If you do not smell gas, continue with the next step.
6. Remove the pilot burner access panel located below and behind the gas control.
7. Find the pilot burner by following the metal tube from the gas control. The pilot burner is between the two burner tubes behind the pilot burner access panel.
8. Turn the gas control knob counterclockwise  to PILOT.
9. Push and hold the gas control knob all the way in. Immediately light the pilot burner flame with a match and continue holding the gas control knob in for one minute after the pilot burner flame is lit.
10. Release the gas control knob and it will pop back up. The pilot burner flame should remain lit. If pilot burner flame goes out, repeat steps one through ten.
  - If the gas control knob does not pop up when released, stop immediately and call your service technician or gas supplier.
  - If the pilot flame will not stay lit after several tries, turn the gas control knob to OFF and call your service technician or gas supplier.
11. Turn the gas control knob counterclockwise  to ON.
12. Replace the pilot burner access panel.
13. Replace the gas control access panel.
14. Reconnect all electric power to the appliance.
15. Set the thermostat to the desired setting.

### TURNING OFF THE APPLIANCE

**VACATION SHUTDOWN**—Set the thermostat to the desired room temperature while you are away.

**COMPLETE SHUTDOWN**—Push the gas control knob in slightly and turn clockwise  to OFF. Do not force. Appliance will completely shut off. Refer to Lighting the Pilot Burner Flame procedures to resume normal operation.

**Honeywell**

*Helping You Control Your World*

**Residential and  
Building Controls Division**

Honeywell Inc.  
1985 Douglas Drive North  
Golden Valley, Minnesota 55422

**Residential and  
Building Controls Division**

Honeywell Limited—Honeywell Limitée  
740 Ellesmere Road  
Scarborough, Ontario  
M1P 2V9

