

## Pilot Burners/Thermocouples

### Application

This document is intended to aid the appliance engineer or authorized service contractor in making a standing pilot application. Pilot burners are manufactured with a variety of tips and mounting configurations. Representative types of mounting with standard pilots are illustrated in Figure 1. Dimensions shown are approximate and may vary, provided the requirements of good ignition are met. See *Good Practice Rules*.

### Good Practice Rules

The following are good practice rules for governing the location of the pilot:

- Locate the pilot so that it can be reached easily for lighting.
- Locate the pilot in a position that has a fixed relation to the main burner (see Figure 1).

#### Mounting Position Examples for Pilot Burners

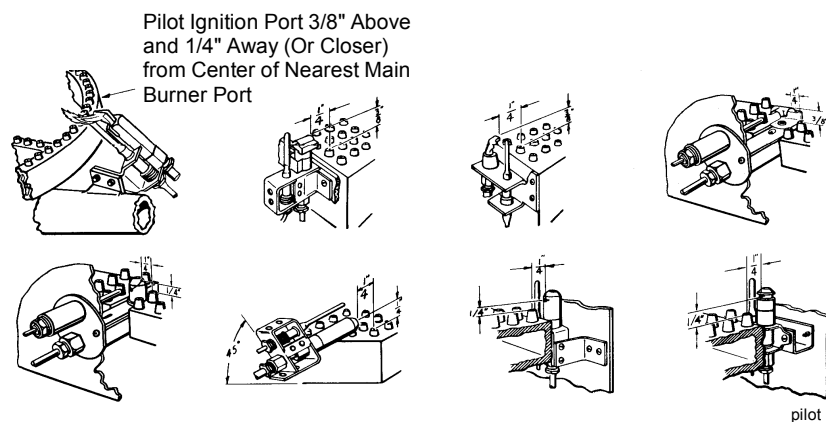

**Figure 1: Pilot Location**

- Locate the pilot burner in a position that will receive incoming air and not products of combustion from the main burner. The pilot should be located where it will not be affected by an excessive draft of incoming air.
- Locate the pilot burner in such a position that it does not receive the full force of igniting or extinguishing puffs from the main burner.
- Locate the pilot burner in a position that will allow ready removal for cleaning.

---

**After  
Installation**

When the pilot burner has been installed, carefully make the following observations and tests:

1. Ensure the main burner flames do not impinge on any part of the pilot burner.
2. Ensure the pilot burner will ignite the main burner under all pilot burner conditions that maintain the safety shutoff device (BASO®) in the On position. (See the *Safety Turn Down Test* section.)
3. Ensure the pilot burner will not be smothered out or snuffed out:
  - when the main burner is ignited from a cold start.
  - when the main burner is ignited with the appliance at the maximum temperature conditions of operation.
  - with normal variation in air adjustments of the main burner.
  - with rapid Off and On operation of the main burner with the combustion chamber cold.
  - with rapid Off and On operation of the main burner with the combustion chamber hot.
  - with continued operation of the main burner.
4. To ensure proper operation, the pilot flame must produce a satisfactory millivoltage as described in the *Thermocouple Output Test* section.

Note: When a pilot is to be applied to an appliance already in the field, obtain the appliance manufacturer's recommendations for the correct pilot specification and location dimensions for the particular model appliance.

---

**Thermocouple  
Output Test**

When the pilot is applied properly, the thermocouple will produce an open circuit millivoltage as shown in Table 1. Normal operating voltages, as shown, must be obtained to give trouble-free performance. Perform the following tests with the Y99AB Test Kit.

**Instructions for  
Testing BASO  
Pilot Burners  
with K15, K16,  
K19, 80, 85, 87,  
and 88  
Thermocouples**

Attach the proper junction terminal of the millivoltmeter to the thermocouple lead and measure the open circuit voltage. Allow at least five minutes for each meter reading. For specifications, see Table 1.

**Table 1: Thermocouple Output Table**

Thermocouple Lead		Turn Down (mV)	Open Circuit Range (mV)	Minimum Fixed Load Voltage (mV)
Series Number	Code Number			
K14	80	4	20 - 28	8
K15	88D, 88F, 88J, 88E, 88H	4	20 - 28	8
K16	87D, 87F, 87K, J87D, K16K, L87D, N87D, K16S, JC87F, L87F	4	25 - 35	8
K19	K19	4	25 - 35	8

**Safety**  
**Turn Down Test**

**WARNING:** **Fire or Explosion Hazard.** Avoid accumulation of unburned gas and resulting personal injury or property damage by making sure the main burner lights under all pilot burner flame conditions that maintain the BASO in the On position. Follow the procedure below to assure the location of the pilot with respect to the main burner is acceptable.

**Turn Down Test with the Use of the Y99AB Test Kit**

To perform the turn down test with the Y99AB Test Kit (purchasable from your Johnson Controls authorized wholesaler):

1. Disconnect the thermocouple from the BASO safety shutoff device and connect it to the test kit (see Figure 2). Hold the BASO in the open position during this test using battery power from the test kit.

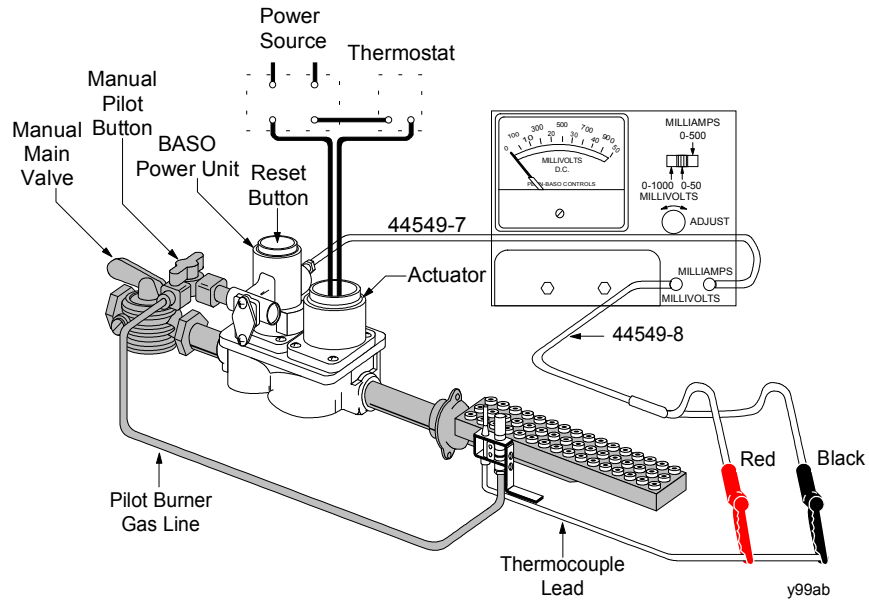

**Figure 2: Using the Y99AB for the Turn Down Test**

2. Reduce the flame on the pilot through the use of the “B” valve to the point where the open circuit millivoltage reading is not more than 4 millivolts.
3. Cycle the main burner On and Off at least three times. The main burner must ignite each time within four seconds.

If you cannot secure ignition of the main burner when the millivoltage reading is 4 millivolts, the pilot has been located improperly with respect to the main burner. Relocate the pilot; repeat Steps 2 and 3.

### Turn Down Test without Instruments

If you do not have the Y99AB Test Kit, perform the turn down test using the following steps:

1. Reduce the flame on the pilot, through the use of the “B” valve to a point where the pilot flame does not impinge on the thermocouple (see Figure 3).

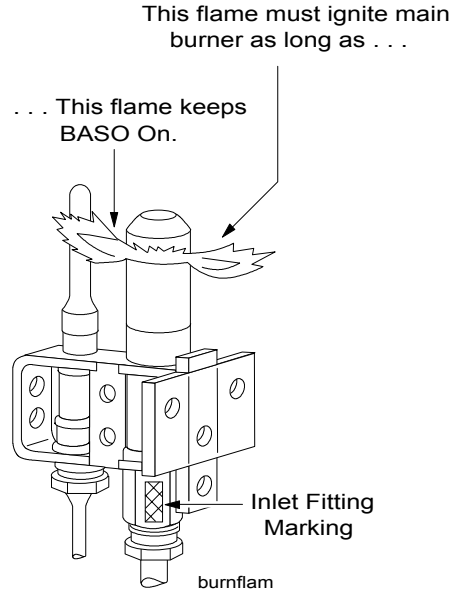

**Figure 3: Turn Down Test without Instruments**

2. Cycle the main burner On and Off at least three times. The main burner must ignite each time within four seconds.
3. Then wait at least three minutes for the BASO to drop out. (Main burner flame will go out.)
4. If the BASO does not drop out, reduce the pilot flame further and repeat Steps 2 and 3.

5. If you cannot secure ignition of the main burner when the pilot flame has been reduced to the point at which the BASO drops out, the pilot has been located too far from the main burner and must be moved closer. Repeat Steps 2, 3, and 4.

Observe the pilot flame under the various test conditions and ensure it appears stable at all times. Use a millivolt meter to determine the stability of the pilot flame. During the observation, or test of pilot performance, position the doors of the appliance in their normal operating position. Good pilot operation can be affected by many draft conditions, appliance design, and recirculation of combustion products.

---

## Notes

---

## Notes

---

# Notes



**Controls Group**  
507 E. Michigan Street  
P.O. Box 423  
Milwaukee, WI 53201

**FAN 121**  
Installation Sheets Manual  
Printed in U.S.A.