

## CONSTRUCTION

- Boosts line pressure up to 50 PSI, for power when you need it
- Rugged cast iron pump housing and motor with easy priming outlet
- Corrosion-resistant storage case for easy transfer to and from job site
- 3/4 in. brass hose adapters connect to standard garden hose
- Includes suction strainer to filter debris, and remove water down to 1/8 in of surface
- 20 ft. SJTW power cord

## APPLICATIONS

- Drainage, dewatering flooded basements, emptying stock tanks, draining water heaters and charging polyglycol radiant heating lines

## MOTOR

- 1/2 HP powerful universal motor

## SWITCH

- Manual operation

# 1/2 HP CAST IRON PORTABLE TRANSFER PUMP WITH STORAGE CASE

MAX FLOW 610 GPH @ 40 PSI



**1/2 HP**



# DIMENSIONAL DATA (INCHES)

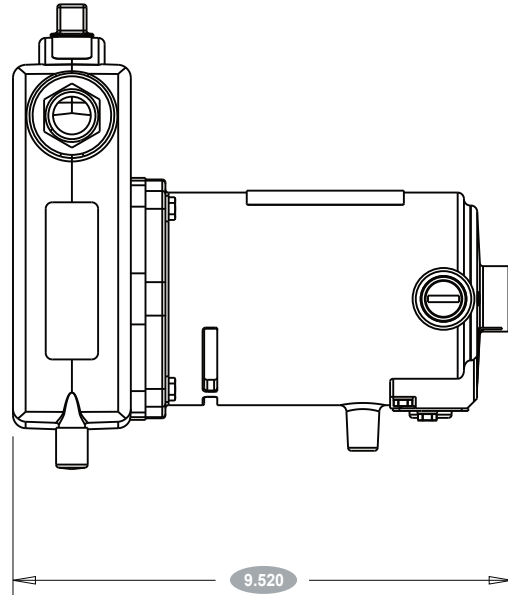
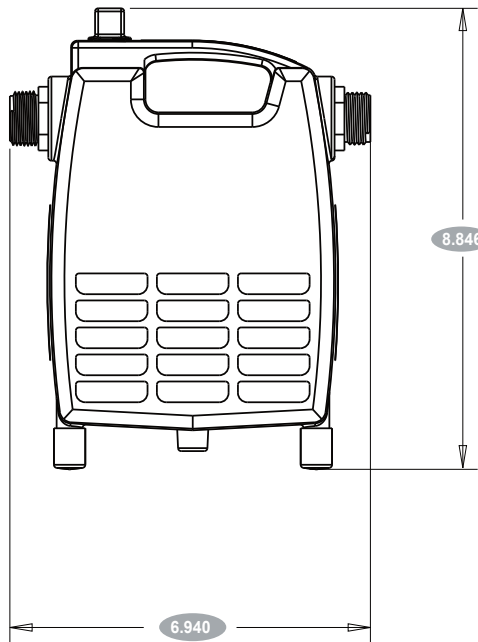

## PUMP SNAPSHOT

			Dimensions (in.)							
HP	Construction	Switch Type	Length	Width	Height	Weight	Volts	Footprint	Power Cord	
1/2	Cast Iron	N/A	9.520	6.940	8.846	25 lbs	120	N/A	20 ft.	
Impeller	Intake	Discharge	Submersible	UPC 0-40066						
Centrifugal	3/4 in.	3/4 in.	Yes	216427						

## TYPICAL APPLICATION

Water removal, draining hot water heaters, flushing water lines, charging polyglycol radiant heating lines

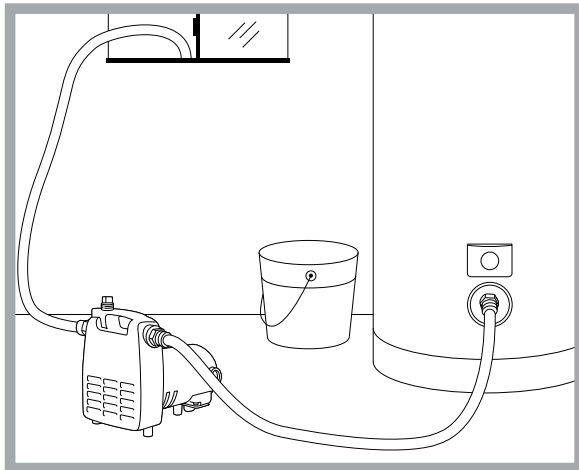

## 50TK PERFORMANCE

Discharge Pressure Per Square Inch	Suction Lift Gallons Per Hour - in feet			
	0 ft.	5 ft.	10 ft.	15 ft.
5	1450	1420	1350	1270
10	1370	1300	1230	1160
15	1250	1190	1120	1040
20	1140	1070	1000	930
25	1020	950	880	810
30	890	820	750	570
35	750	680	620	550
40	610	540	480	410