

AE²

Reference Guide
for Authorized Wholesalers



Tecumseh



A Legend Reborn
The Next Generation Compressor

 Canada



A Legend Reborn.

Throughout its history, Tecumseh Products Company has been a leader in providing customers with efficient and reliable products for commercial refrigeration and air conditioning applications. As a result, commercial refrigeration equipment manufacturers, wholesale distributors and service contractors continue to demand the AE compressor for their specific needs. Following on the path of its predecessor, the AE² delivers best-in-class efficiency, a 20% greater capacity range, a smaller size envelope and Tecumseh's industry known standard for reliability.

The AE² is well positioned to be the replacement compressor of choice.

● **REDUCED ENERGY CONSUMPTION**

Most efficient compressor of its size on the market.

● **WIDER CAPACITY IN A SMALLER ENVELOPE**

Reduced size envelope covers capacities normally served by larger compressors.

● **ENVIRONMENTALLY FRIENDLY**

Designed for optimal performance with "Green" hydrocarbon refrigerant R290. (Supports HFCs R134a and R404A).



● **SERVICE AND SUPPORT**

Backed by Tecumseh's network of knowledgeable application engineers, test labs & support personnel.

● **PRODUCT OFFERING**

Available across the globe, with flexibility to meet regional needs and agency approvals.

● **PROVEN RELIABILITY**

Leverages robust design attributes developed from 50-years of AE commercial refrigeration experience.



**AVAILABLE
ORDER TODAY**

Table of Contents

Introduction	2
Overview	4
Agency Approvals	4
Warranty Process.....	4
What's New.....	5
Dimensional Drawings	5
Product Marketing	6
Compressor Model Nomenclature	6
Compressor Item Number/Serial Label ..	7
Models Released	8
Cross Reference	9
What's in a Single Pack?	10
Replacement Parts Program	11
Ease of Change Out	12
Product Dimensions and Weights.....	13
FAQs and Tech Tips.....	14



AE² Compressor with a Housing Mounted Suction Service Valve



AE² Compressor with Solder Connections

OVERVIEW

Product Strategy

- The AE² is compatible (designed as a replacement for the legacy AE) in terms of mounting footprint, physical size, electrical ratings and cooling capacity.
- The new design delivers high efficiency performance, along with an expanded capacity range in a smaller envelope. Depending on the refrigerant type and operating conditions, the AE² is anywhere from 15% to 45% more efficient than the legacy AE compressor.
 - ▶ North America OEM's have initiated hydrocarbon testing and the AE² is optimized for hydrocarbon refrigerant R290 (propane).
- A standard line of AE² compressors to accommodate stand-alone compressor requirements as well as integration into Tecumseh's line of fractional horsepower (HP) air, water cooled and evaporative condensate condensing units.
 - ▶ The compressor product line will use the same configuration for OEM's, Condensing Units and Replacement facilitating ease of change out on new applications.
 - ▶ Standardization was aimed at delivering the fewest number of models that are required to serve you, our customer, and market needs.
- All models are equipped with sweat connections (ODF) where the suction and discharge tubes are oriented in the "Up" position.
- Some AE² models incorporate a Compressor Housing Mounted Suction Service Valve.
 - ▶ Once available inventory of legacy AE compressor models is depleted, all remaining orders will be converted to respective AE² compressor models.
 - ▶ Models will be offered in J7 (single pack) configuration.
- A comprehensive cross reference is available, please refer to page 9.
- An updated price list that includes AE² compressors will be sent to all authorized wholesalers' designated contact(s).

Note: Genuine Tecumseh electrical components for the legacy AE will continue to be serviced by Tecumseh.

Agency Approvals

- AE² compressor models released in North America are cURus Recognized (File SA707).

Warranty Process

- The Warranty and Return Process for AE² compressors remains the same.

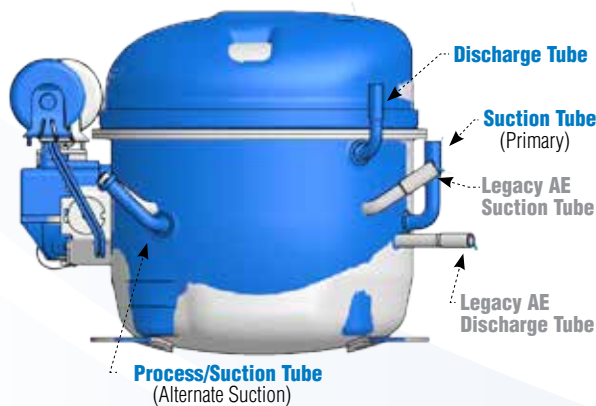

Housing	DCAE212	AE ²
Housing	DCAE717	AE

Note: For housing comparison only.



What's New...

- Compressor Model Number and Item Number (Bill of Material). See pages 6-7.
- AE² component and electrical parts are not interchangeable with the legacy AE.
- Future model releases will include an expanded range of the AE² refrigerant capacities, which have traditionally been served by LARGER compressors, that now can be serviced by this smaller, more efficient compressor. This is especially important for compact applications where the available space is limited.
- Legacy AE series compressors were produced with many different tubing configurations. Note: The suction and discharge tubes for AE² series compressors are oriented in the “Up” position (see illustration).
- HBP and LBP versions of the AE² compressor were released as an element of product line standardization, reducing the need for a CBP / MBP offering. The AE² compressor has an extended HBP evaporating range of +5°F to +59°F (-15.0°C to +15°C) which is different from the legacy AE that has an HBP evaporating range of +20°F to +55°F (-6.7°C to +12.8°C).

DIMENSIONAL DRAWINGS

Housing	Dim. Dwg.	Overall		Process Tube		Suction Tube/Valve		Discharge Tube	
		Height	Dim. Dwg.	Height	Dim. Dwg.	Height	Dim. Dwg.	Height	Dim. Dwg.
DCAE106	A	194.60 - 199.60	B	91.60 - 96.60	C	117.20 - 122.20	D	151.10 - 156.10	
DCAE209	A	205.60 - 210.60	B	91.60 - 96.60	C	129.80 - 134.80	D	151.10 - 156.10	
DCAE212	A	194.60 - 199.60	B	91.60 - 96.60	C	117.20 - 122.20	D	151.10 - 156.10	
DCAE214	A	205.60 - 210.60	B	91.60 - 96.60	C	129.80 - 134.80	D	151.10 - 156.10	
DCAE215	A1	194.60 - 199.60	B1	91.60 - 96.60	C1	74.70 - 77.70	D1	151.10 - 156.10	
DCAE220	A1	205.60 - 210.60	B1	91.60 - 96.60	C1	74.70 - 77.70	D1	151.10 - 156.10	
DCAE677	A	205.60 - 210.60	B	91.60 - 96.60	C	129.80 - 134.80	D	151.10 - 156.10	
DCAE679	A	205.60 - 210.60	B	91.60 - 96.60	C	129.80 - 134.80	D	151.10 - 156.10	

With Solder Connections

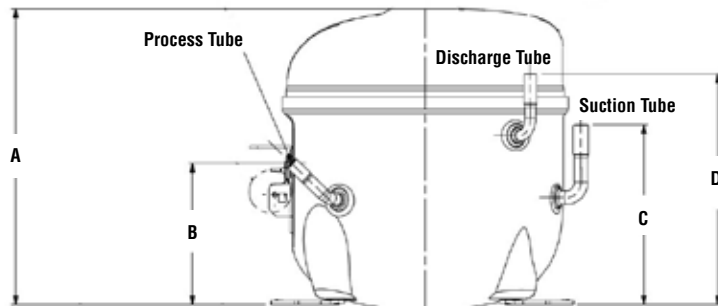

Housing Mounted Suction Service Valve

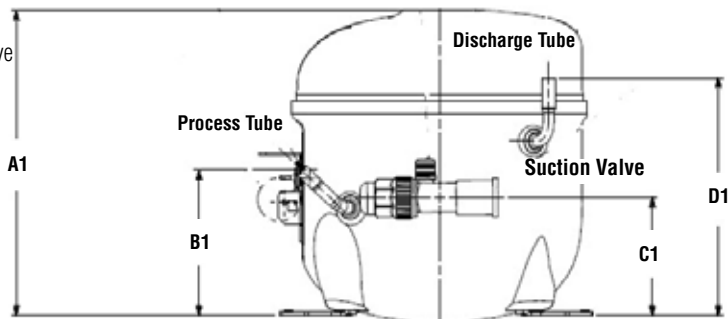

Note: These drawings are for reference only, as housings can vary. Please refer to housing drawings for actual dimensions.

PRODUCT MARKETING

COMPRESSOR MODEL NOMENCLATURE

(AE² models only)

AE

4

440

Y

=

AA

1A

All models except AE²

AEA

4

440

Y

XA

Compressor Family (First Two Digits) Release Variant (The Third Digit)	Application	First Digit is the No. of Digits in Btu/h Capacity Last Two Digits are the First Two Digits in Rated Btu/h Capacity	Refrigerant	Voltage	Release Variant (AE² models only)
---	--------------------	--	--------------------	----------------	---

Examples:
AE² model number:
AE4440Y-AA1A

Model number except AE²:
AEA4440YXA

AE
AG
AH
AJ
AK
AN
AV
AW
AZ
RG
RK
SA
SF
TP
HG
TH
TW
VS

A = 1st
B = 2nd
C = 3rd
etc...

In this example (4) total digits, with the first two (40), or 4,000 BTU capacity

Primary Application Parameters		
Evap Temperature	Rating Point	Motor Starting Torque
1. Low	-10°F	Normal
2. Low	-10°F	High
3. High	+45°F	Normal
4. High	+45°F	High
5. Air Cond	+45°F	Normal
6. Medium	+20°F	Normal
7. Medium	+20°F	High
8. Air Cond	+49°F	Normal
9. Commercial	+20°F	High
0. Commercial	+20°F	Normal
F. Low – Vapor Inj	-10°F	High
G. Low – Liquid Inj	-10°F	High

Primary Refrigerants
A = R12
B = R410A
C = R407C
E = R22
J = R502
U = R290
Y = R134a
Z = R404A/R507

The first digit is the Motor Type; The next digit is the Motor Efficiency
1 = Induction Run (RSIR/ CSIR)
2 = Optional Run Cap
3 = Capacitor Start/Run (CSR)
A = Standard Efficiency
B = Medium Efficiency
C = High Efficiency

Voltage Codes
AA = 115/60/1
AB = 115/60/1; 90/50/1
FZ = 220-240/50/1
DS = 115-127/60/1
NA = 208-230/60/1
VA = 265/60/1; 220-240/50/1
XA = 115/60/1; 100/50/1
XB = 230/60/1; 200/50/1
XC = 220-240/50/1
XD = 208-230/60/1; 200/50/1
XF = 208-230/60/3; 200-240/50/3
XG = 460/60/3; 380-420/50/3
XH = 575/60/3; 480-520/50/3
XN = 208-230/60/1; 200-220/50/1
XP = 220/60/1; 200/50/1
XT = 200-230/60/3; 200-220/50/3
XU = 100/60/1; 100/50/1
XV = 265/60/1

NOTE: For explanation of compressor families and codes, contact Tecumseh Products Company.

COMPRESSOR ITEM NUMBER (BILL OF MATERIAL)

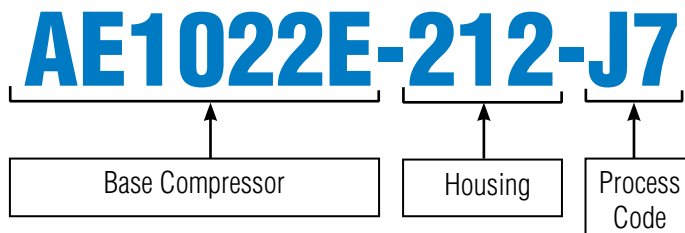

SERIAL LABEL

Current Serial Label (All Tecumseh Compressor Series)

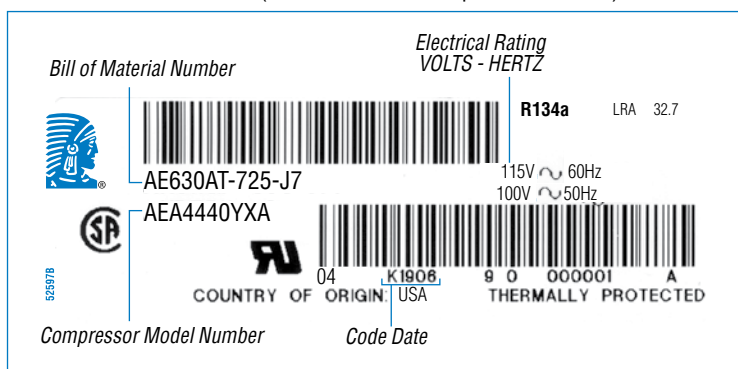

The new serial label design incorporates the same item attributes, but now includes a yellow warning box in the top right corner. This yellow warning box will be on all serial labels and will include the symbol for compressors designated for use with flammable refrigerants.



AE² Serial Label (product manufactured September 2012)

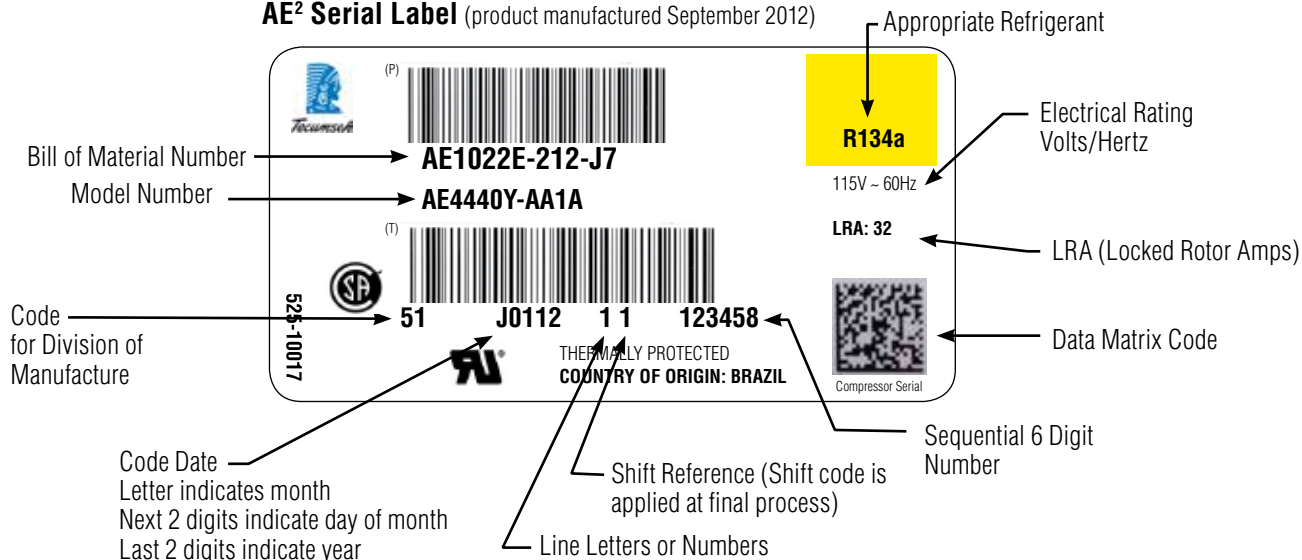

A – January	D – April	G – July	K – October
B – February	E – May	H – August	L – November
C – March	F – June	J – September	M – December

WHAT'S IN A SINGLE PACK?

To facilitate ease of change-out, Tecumseh has provided the following support documentation with purchase;





- ## CHECKLIST
- Compressor
 - Overload
 - Relay (if required)
 - Start Cap (if required)
 - Capacitor Screw (if required)
 - Protective Cover
 - Protective Cover Screw
 - Installation Instructions (Pub #TR-302 CAN, TPC#132-100EN, 132-100FR)*
 - Discharge Tube Hang Tag (TPC#126-10080)*
 - Tube Adaptor Kit*
 - Mounting Accessories (LP3)

*See Appendix for full details

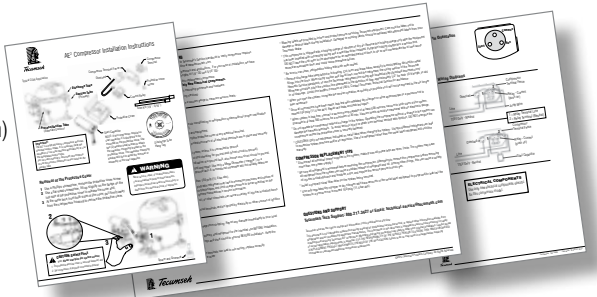
ELECTRICAL COMPONENTS
 Use only new electrical components specific for that compressor model.



Wholesale Carton Label

TECUMSEH COMPRESSOR COMPANY	
PART NO. AE1022E-212-J7	
	
MODEL AE4440Y-AA1A	VOLTAGE 115V ~ 60 PH 1
	
SERIAL NO. 04h271231802444x	
	
(S)	
840820100 BB1 - 797 Carton Label SP1.hst	7850378

Second Wholesale Carton Label - Cross Reference

AE² Compressor Model AE4440Y-AA1A P/N AE1022E-212-J7
Replaces: TECUMSEH AEA4440YXA
COPELAND ARE37C3E-IAA
DANFOSS NF11FX.2
EMBRACO NEK6210Z

Note: The Cross Reference information listed on this diagram is for example purposes only. For the most current information refer to the competitive cross reference available on Tecumseh's Web Application site.



REPLACEMENT PARTS KITS

“K” Replacement Relay, Overload and Capacitor Kits has been established for the AE² compressors. The kits are designed to simplify servicing of compressor relays, overloads and capacitors on refrigeration and air conditioning equipment. Genuine Tecumseh electrical components are included, along with the hardware (leads, terminal adapters and mounting screws in a sealed plastic bag) needed to make installation quick and easy.

OVERLOADS and RELAYS

Refrig	Compressor	Motor Type	Overload	Relay	Capacitor
HBP (High Back Pressure) Application +5°F to +59°F (-15°C to +15°C)					
R134a	AE3425Y-AA1A	RSIR	K90-54	K71-34	
R134a	AE3430Y-AA1A	RSIR	K90-60	K71-42	
R134a	AE4430Y-AA1A	CSIR	K90-55	K71-35	K146-17
R134a	AE4430Y-XN1A	CSIR	K90-83	K71-68	K146-02
R134a	AE3440Y-AA1A	RSIR	K90-60	K71-42	
R134a	AE4440Y-AA1A	CSIR	K90-56	K71-36	K146-55
R134a	AE4440Y-XN1A	CSIR	K90-64	K71-44	K146-02
R134a	AE4450Y-AA1A	CSIR	K90-61	K71-41	K146-55
R404A	AE4450Y-XN3C	CSR	K90-108	K71-30	K146-69
R404A	AE4425Z-AA1A	CSIR	K90-65	K71-45	K146-28
R404A	AE4430Z-AA1A	CSIR	K90-66	K71-46	K146-55
R404A	AE4440Z-AA1A	CSIR	K90-67	K71-47	K146-28
R22	AE4430E-DS1A	CSIR	K90-55	K71-35	K146-55
R22	AE4450E-DS1B	CSIR	K90-93	K71-73	K146-55
R22	AE4456E-DS1B	CSIR	K90-116	K71-48	K146-55
LBP (Low Back Pressure) Application -40°F to +10°F (-40°C to -12.2°C)					
R134a	AE1390Y-AA1A	PTCSIR	K90-62	K71-87	
R134a	AE2410Y-AA1A	CSIR	K90-58	K71-38	K146-28
R134a	AE2413Y-AA1B	CSIR	K90-59	K71-39	K146-55
R404A	AE2410Z-AA1A	CSIR	K90-57	K71-37	K146-28
R404A	AE2415Z-AA1A	CSIR	K90-59	K71-39	K146-28
R404A	AE2420Z-DS1B	CSIR	K90-117	K71-85	K146-14
R12 EQ.	AE2410A-AA1A	CSIR	K90-58	K71-38	K146-28
R12 EQ.	AE2413A-AA1B	CSIR	K90-59	K71-39	K146-55

SINGLE-PHASE COMPRESSOR WIRING DIAGRAMS

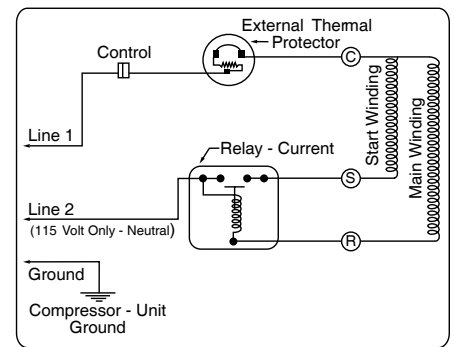

FIGURE 3-1: RSIR motor diagram with current relay

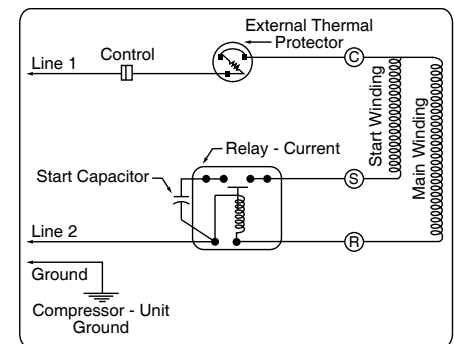

FIGURE 3-3: CSIR motor diagram

REMINDER:



AE² component and electrical parts are not interchangeable with AE compressor component and electrical parts. Use only new electrical components specific for that compressor model.

CREATING VALUE AND EASE OF CHANGE-OUT

Tecumseh provides the following:

1. Compressor Discharge Tube Hang Tag to orient the customer to the correct tubing location.
2. A Copper Tube Adaptor Kit (LP194-C) to facilitate ease of change out. The tubes are swedged on one end and individually packed.
3. Second Carton Label with cross reference (Tecumseh and competitive) has been added to assist wholesalers and their customers.
4. Detailed Installation Instructions including specified wiring diagrams.

1. Compressor Discharge Tube Hang Tag

A 3" round tag with a star cut in the middle to hang on the discharge tube. This is provided in English/Spanish on one side and English/French Canadian on the other.

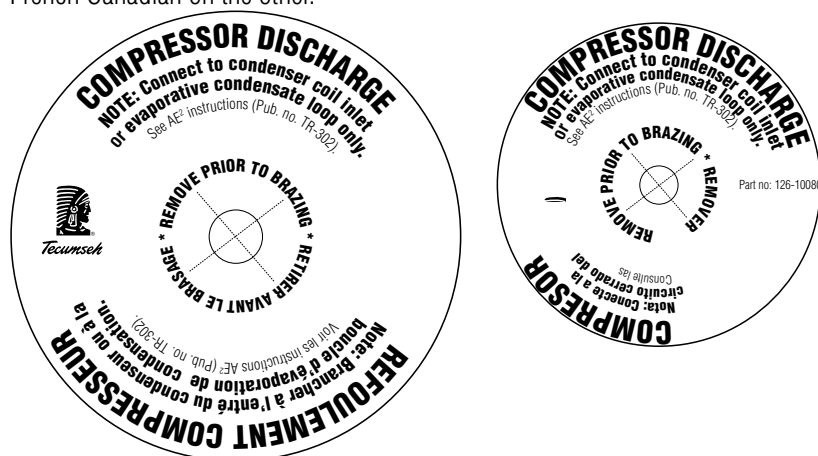

2. Copper Tube Adaptor Kit (LP194-C)

Tubing sizes and orientation may vary between compressors and applications. For your ease of installation, we have included a 11" length of 1/4" OD and 5/16" OD copper tubing swedged at one end.

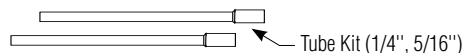

Part No.	Suction Tube OD
58005-A001	5/16" Tube
58004-A001	1/4" Tube

Note: Compressors with the Housing Mounted Service Suction Valve will only contain 1/4" tube for discharge installation (LP195-C).

3. Second Wholesale Carton Label - Cross Reference

This label with cross reference (Tecumseh and competitive) has been added to assist wholesalers and their customers.

Second Wholesale Carton Label - Cross Reference

AE² Compressor Model AE4440Y-AA1A
P/N AE1022E-212-J7

Replaces:
TECUMSEH
 AEA4440YXA

COPELAND
 ARE37C3E-IAA

DANFOSS
 NF11FX.2

EMBRACO
 NE6187Z

Note: The Cross Reference information listed on this diagram is for example purposes only. For the most current information refer to the competitive cross reference available on Tecumseh's Web Application site.

4. Installation Instructions

Comprehensive installation instructions include compressor removal and replacement tips, safety precautions and wiring diagrams.

Product Dimensions and Weights

Model	Compressor ONLY Weight - lbs. (kg)	J7 Configuration
AE1390Y-AA1A	22 (9.70)	AE1191E-106-J7
AE2410A-AA1A	23 (10.20)	AE1249E-679-J7
AE2410Y-AA1A	22 (10.20)	AE1156E-679-J7
AE2410Z-AA1A	22 (9.80)	AE1126E-106-J7
AE2413A-AA1B	24 (10.80)	AE1255E-679-J7
AE2413Y-AA1B	24 (10.80)	AE1240E-679-J7
AE2415Z-AA1A	22 (10.20)	AE1157E-679-J7
AE2420Z-DS1B	24 (10.6)	AE1322E-679-J7
AE3425Y-AA1A	20 (9.00)	AE1004E-212-J7
AE3425Y-AA1A	20 (9.13)	AE1198E-215-J7*
AE3430Y-AA1A	21 (9.50)	AE1153E-212-J7
AE3440Y-AA1A	21 (9.70)	AE1155E-212-J7
AE4425Z-AA1A	21 (9.50)	AE1166E-212-J7
AE4430E-DS1A	24 (10.6)	AE1320E-212-J7
AE4430Y-AA1A	21 (9.40)	AE1023E-212-J7
AE4430Y-AA1A	21 (9.57)	AE1199E-215-J7*
AE4430Y-XN1A	23 (10.5)	AE1188E-212-J7
AE4430Z-AA1A	22 (9.80)	AE1167E-212-J7
AE4440E-DS1A	24 (10.60)	AE1483E-209-J7
AE4440Y-AA1A	21 (9.70)	AE1022E-212-J7
AE4440Y-AA1A	22 (9.77)	AE1200E-215-J7*
AE4440Y-XN1A	24 (10.60)	AE1204E-209-J7
AE4440Z-AA1A	23 (10.20)	AE1168E-209-J7
AE4450E-DS1B	25 (11.3)	AE1363E-209-J7
AE4450Y-AA1A	24 (10.70)	AE1154E-209-J7
AE4450Y-AA1A	24 (10.70)	AE1395E-220-J7*
AE4450Y-XN3C	24 (10.70)	AE1294E-677-J7

* Housing Mounted Suction Service Valve included.



FAQs

- Q** Is the AE² a replacement for the Tecumseh AE?
A **Yes, the AE² is compatible (designed as a replacement) with the legacy AE in terms of mounting footprint, physical size, electrical ratings and cooling capacity.**
- Q** Is there a AE² replacement for all legacy AE wholesale compressors?
A **No. Most legacy AE compressors will have a replacement AE² version. Some AE compressors are being replaced with TH compressors and there are a few AE models that will not have a subsequent replacement. See Cross Reference on page 9.**
- Q** Can I buy the same model of either AE or AE² compressors?
A **No, once available inventory of the legacy AE model is depleted, all future orders would be converted to the AE² compressor.**
- Q** Are there any changes to the way I process warranty returns?
A **No, the Wholesale Warranty and Return Process remains unchanged.**
- Q** I already stock electrical service parts for the AE compressor, can I use those service parts on the AE²?
A **No, AE² component and electrical parts are not interchangeable with legacy AE compressors.**
- Q** Can I get service components and electrical parts for the AE²?
A **Yes, Tecumseh has established new “K” replacement relay and overload kits.**
- Q** Will the AE² be used in Tecumseh Condensing Units?
A **Yes, AE² compressors has been integrated into Tecumseh’s line of fractional horsepower air cooled condensing units and evaporative condensate condensing units.**
- Q** Will I receive a new price list?
A **Yes. An updated price list has been sent to all authorized wholesalers’ designated contact(s).**
- Q** What are the advantages of the new AE² compressor?
A **The new design delivers high efficiency performance, along with an expanded capacity range in a smaller envelope. Depending on the refrigerant type and operating conditions, the AE² is anywhere from 15% to 45% more efficient than the legacy AE compressor. The AE² is optimized for hydrocarbon refrigerant R290 (propane).**
- Q** Are OEM's using the AE² compressor?
A **Yes. It has been tested and approved by major OEM's around the world.**
- Q** CBP R404A models of the legacy AE were available, what AE² models do I use as a replacement?
A **The AE² compressor has an extended HBP evaporating range of +5°F to +59°F (-15.0°C to +15°C) which is different from the legacy AE that has an HBP evaporating range of +20°F to +55°F (-6.7°C to +12.8°C). Therefore, AE² HBP R404A models will adequately cover the required CBP evaporator temperature range.**

TECH TIPS

Tecumseh has developed a number of tools to help you sell, while also helping your customer sell.

Website: www.tecumseh.com

Tecumseh's portal to the world, the website offers product information, compressor data sheets, wholesaler location lookup, basic cross-referencing and a library filled with marketing brochures/catalogs, application bulletins and more.



Tecumseh Web Applications

A suite of online web application tools that eliminates the guess work. Site includes product and component look up, cross reference tools, drawings, along with performance data. Analytical tools are also available for use including, refrigerant line sizing and calculating box (heat) load requirements. Go to the website at, <http://boxload.tecumseh.com/>

Tecumseh Web Applications

[Box Load Program](#) [Capillary Tube Sizing Program](#)
[Condensing Unit Data Sheets](#) [Evaporator Coil Data Sheets](#)
[Electrical Service Parts Guidebook](#) [Competitive Cross Reference](#)
[Condensing Unit Fast Reference](#) [Compressor Fast Reference](#)
[Part Number Fast Reference](#) [Refrigerant TP-PT Chart](#)
[Compressor Performance Data](#) [Condensing Unit Performance Data](#)
[System Analyzer](#) [Refrigerant Line Sizing](#)
[3-Phase Voltage Imbalance Calculator](#) [Compressor Housing Drawings](#)
[Units of Measurement Converter](#)

Online Literature

Tecumseh's online literature portal, located under the "Library" tab of www.tecumseh.com, provides downloadable and searchable PDF versions of all catalogs, brochures and reference booklets produced.

Mobile Tech to Go

These apps are the electronic version of Tecumseh's Electrical Service Parts & Cross Reference tools. For iPhone®/iPad® and Android® devices.



iPhone/iPad



Android Device



<https://itunes.apple.com/us/app/tecumseh/id502258181?mt=8>

<https://play.google.com/store/apps/details?id=com.logic>



TECUMSEH PRODUCTS CANADA

SALES AND MARKETING

Tecumseh Products Canada

200 Elm Street

Alymer, Ontario N5H 2MB

Tel. 519-765-1556

Fax: 519-765-1574

can.sales.marketing@tecumseh.com

TECHNICAL SERVICES

Tel. 800-211-3427

can.tech.support@tecumseh.com

For more information on products by Tecumseh,
please visit our website www.tecumseh.com



Tecumseh