

CR20-W



UPC Code: 07847781545

Country Of Origin: United States

* Eligible for ARRA funded projects

NEMA:
5-20R



Made in USA



CR20-W

Brand Features

Leviton's line of Heavy-Duty Specification Grade receptacles are designed and manufactured to withstand the most demanding environments. Available in a wide variety of configurations, including isolated ground, tamper-resistant, etc., these Commercial Grade devices are the electrical contractor's choice for use in hotels, schools, hospitals and commercial office buildings.

Item Description

20 Amp, 125 Volt, NEMA 5-20R, 2P, 3W, Narrow Body Duplex Receptacle, Straight Blade, Commercial Grade, Self Grounding, , , Side Wired, Steel Strap, - White

Technical Information

AC Horsepower Ratings

At Rated Voltage: 1 HP

Electrical Specifications

Dielectric Voltage: Withstands 2000V per UL498

Grounding: Self-Grounding

Temperature Rise: Max 30C after 100 cycles OL at 150 percent rated current

Voltage: 125 Volt

Amperage: 20 Amp

Current Limiting: Full Rated Current

Wire: 3

Pole: 2

Environmental Specifications

Operating Temperature: -40C to 60C

Flammability: Rated V-2 per UL94

Material Specifications

Strap Material: Zinc-Plated Steel

Face Material: Thermoplastic

Body Material: Thermoplastic

Ground Clips: Brass

Terminal Screws: Steel 8-32

Line Contacts: Brass .031 Thick

Grounding Screw: Steel 8-32

Mechanical Specifications

Product ID: Ratings are permanently marked on device

Terminal ID: Brass-Hot, Green-Ground, Silver-Neutral

Termination: Side

Terminal Accom.: 14-10 AWG

Product Features

Color: White

NEMA: 5-20R

Standards and Certifications

Warranty: 10 Year Limited

CSA C22.2 No. 42: File 152105

ANSI: C-73

UL498: File E13399

NOM: 057

NEMA: WD-1 & WD-6

Dimensional Diagram

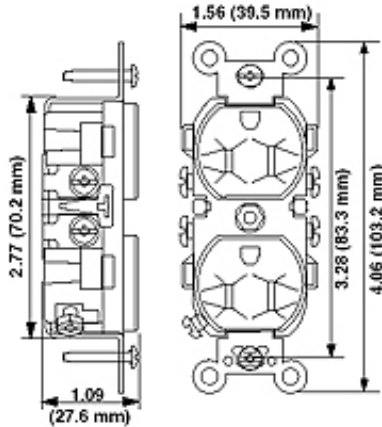

Wiring Diagram

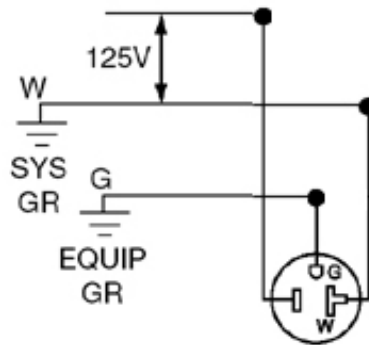

5-20R

SPECIFICATION SUBMITTAL

JOB NAME: <input type="text"/>	CATALOG NUMBERS: <input type="text"/>	<input type="text"/>
JOB NUMBER: <input type="text"/>	<input type="text"/>	<input type="text"/>

Leviton Manufacturing Co., Inc.

201 North Service Road, Melville, NY 11747

Teléfono: +1-800-323-8920 · FAX: +1-800-832-9538 · Tech Line (8:30AM-7:30PM E.S.T. Monday-Friday): +1-800-824-3005

Leviton Manufacturing of Canada, Ltd.

165 Hymus Boulevard, Pointe Claire, Quebec H9R 1E9 · Telephone: +1-800-469-7890 ·

FAX: +1-800-824-3005 · www.leviton.com/canada

Leviton S. de R.L. de C.V.

Lago Tana 43, Mexico DF, Mexico CP 11290 · Tel.: (+52)55-5082-1040 · FAX: (+52)5386-

1797 · www.leviton.com.mx

Visit our Website at: www.leviton.com

© 2012 Leviton Manufacturing Co., Inc. Todos los derechos reservados. Subject to change without notice.

Leviton has a global presence.

If you would like to know where your local Leviton office is located please go to:

www.leviton.com/international/contacts/



**Leviton is the smart choice, providing the most comprehensive range of solutions to meet the needs of today's residential, commercial and industrial buildings. Leveraging more than a century of experience, Leviton helps customers create sustainable, intelligent environments through its electrical wiring devices, network and data center connectivity solutions, and lighting energy management systems. From switches and receptacles, to daylight harvesting controls, networking systems, and equipment for charging electric vehicles, Leviton solutions help customers achieve savings in energy, time and cost, all while enhancing safety.*