

## Condensate Pump Comparison Chart

Feature	MARS	Comp. 1	Comp. 2	Comp. 3
Lift 24 ft.	✓			
Quick Release & Clean Check Valve	✓			
Ball Bearing Motor Construction	✓			
1/25 <sup>th</sup> H.P. Motor	✓			
Motor Stack Corrosion Protection	✓			
Elevated Motor & Switches	✓			
Vibration Absorbing Rubber Feet	✓	✓	○	
Integrated Side Mount	✓	✓	✓	✓
Standard Safety Switch	✓	✓		
Solid Float	✓		✓	✓
Score	10	3	2	2

\*Note ○ = Optional on some models

## Gallons Per Hour Pump Performance Comparison Chart

Foot Lift	1	5	10	15	20	24
<b>MARS</b>	125	98	74	70	<b>43</b>	<b>7</b>
Comp. 1	84	75	60	42	10	0
Comp. 2	117	98	70	58	11	0
Comp. 3	105	95	73	36	0	0

### 24' Pump



### Low Profile 22' Pump



### 16' Pump



www.marsm-a.com

98616

*introduces a...*

# More Powerful Pump



- 24' Lift
- "Quick Clean" Check Valve



## Features:

- ❑ **ABS Plastic Housing** –
  - One of the most durable plastics available.
- ❑ **Stainless Steel Components**
  - Resists rust and corrosion.
- ❑ **1/25 HP Motor – Ball Bearing Construction**
  - Quiet operation with a motor life 10X existing pumps
  - Thermally protected motor
- ❑ **Standard – Overflow Safety Switch**
  - Reduces potential water damage
  - Easily reconfigured from NC to NO contacts
- ❑ **Integrated- Side Mount Brackets**
  - No hardware or brackets to lose
- ❑ **Check Valve - Quick Release – Positive Lock**
  - Tool-less – quick clean check valve
  - No need to remove condensate drain line when cleaning.
  - Silicone Duck Bill design for long life. Resists clogging
- ❑ **Drip Proof Housing**
  - Eliminates water and debris from entering the motor housing
- ❑ **Solid Float Construction with Stand-Off**
  - Eliminates float deterioration and malfunction
- ❑ **Reversible Motor Housing**
  - Speeds installation and eliminates the need to change plumbing configuration

## MARS Condensate Pump Features

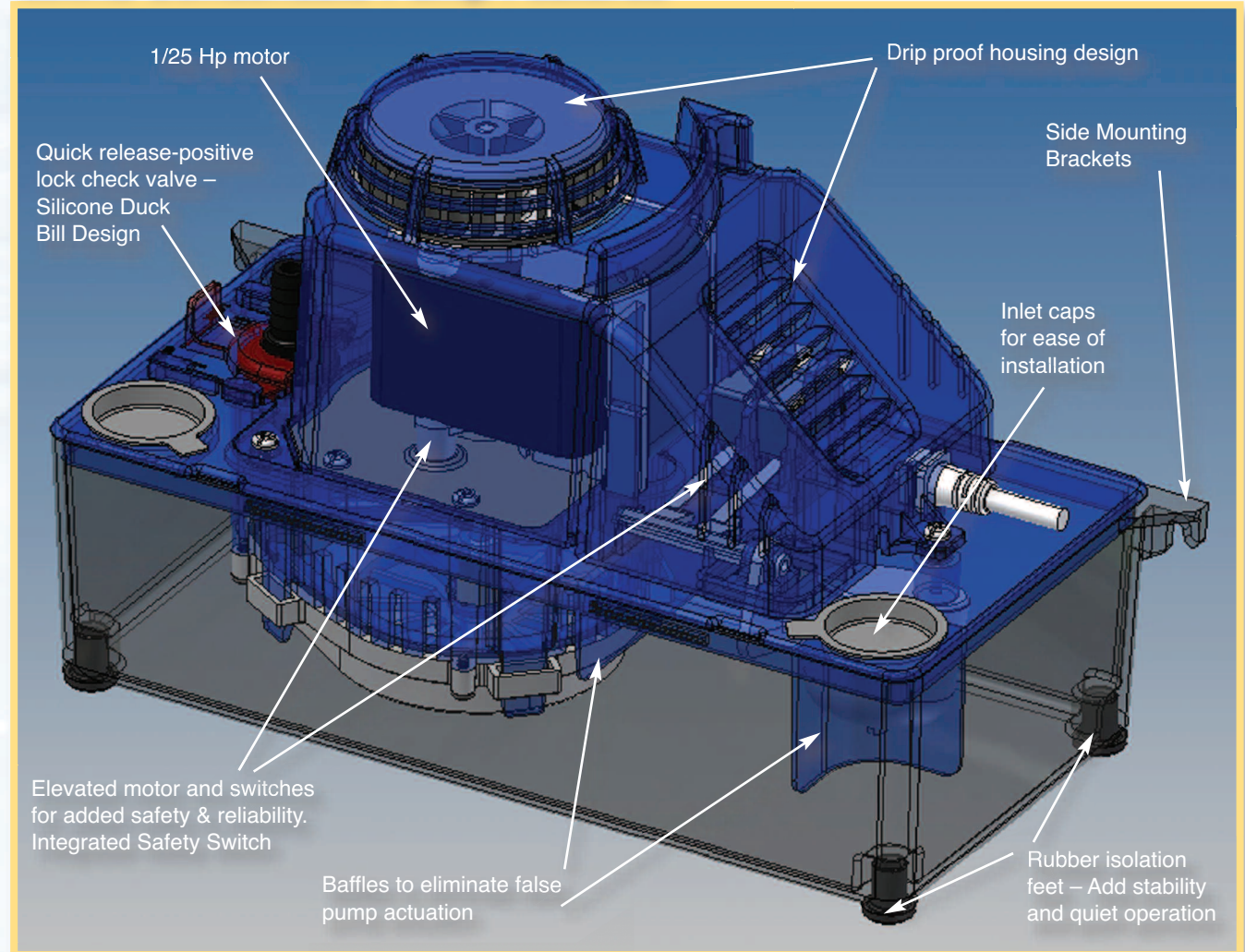

Lift	MARS #	Description
<b>24' Lift</b>	<b>21780</b>	115 V, 60 Hz, 0.91 Amps, 71 Watts, 6' Cord, 3/8" Check Valve, Safety Switch, Medium Reservoir
	<b>21781</b>	115 V, 60 Hz, 0.91 Amps, 71 Watts, 6' Cord, 3/8" Check Valve, Safety Switch, 20' Tubing, Medium Reservoir
	<b>21782</b>	230 V, 60 Hz, 0.6 Amps, 75 Watts, 6' Cord, 3/8" Check Valve, Safety Switch, Medium Reservoir
	<b>21783</b>	230 V, 60 Hz, 0.6 Amps, 75 Watts, 6' Cord, 3/8" Check Valve, Safety Switch, 20' Tubing, Medium Reservoir
<b>22' Lift</b>	<b>21784</b>	<b>Low Profile</b> 115 V, 60 Hz, Low Profile, 22' Lift, 3/8 Check Valve,, Safety Switch
	<b>21785</b>	<b>Low Profile</b> 230 V, 60 Hz, Low Profile, 22' Lift, 3/8 Check Valve, Safety Switch
<b>16' Lift</b>	<b>21786</b>	115 V, 60 Hz, 16' Lift, 3/8 Check Valve, Safety Switch, Medium Reservoir