

SPEC AMERICAN. SPEC BRIDGEPORT.



Bridgeport Zinc or Steel Meets:

- UL514B
- Federal Specifications:
 - A-A-50552**
Fittings for Cable and Flexible Metal Conduit
 - A-A-50553**
Fittings for Rigid and EMT Conduit
 - A-A-50563**
Conduit Outlet Boxes, Bodies and Entrance Caps
- NEMA FB-1
- NEC Application Requirements



**FOR 86 YEARS,
BRIDGEPORT HAS BEEN CASTING
A STRONG, MIGHTY AMERICA.**

Employing American workers, building American products, investing in American operations and improving the American community. You are an American. Spec American. Spec Bridgeport. Find the American-made products for your projects at: www.bptfittings.com/american





ZINC'S CONFORMANCE TO SPECIFICATIONS

Federal specifications clearly permit the use of product constructed of zinc alloy. Bridgeport's

zinc fittings may be used on all American Recovery and Reinvestment Act funded projects. As a material used in the manufacture of electrical conduit and cable fittings, Bridgeport's zinc product conforms to a number of specifications including:

- **Federal Specifications:** A-A-50552, A-A-50553 and A-A-50563
- **Third Party Specification Standards:** UL514B, CSA C22.2 18.3-04
- **NEMA Specification Standard:** FB-1
- **National Electrical Code**



THE ZINC ADVANTAGE OVER STEEL

- Zinc Meets or Exceeds the Same Stringent UL514B Fitting Standards as Steel
- Lower Total Cost Solution. Total Cost Savings Approximately 4 to 5 Times Using U.S. Made Zinc Versus U.S. Made Steel

- Dimensional Consistency Ensures Product Quality
- Inherent Corrosion Protection
- Functional Advantages Ensure Trouble-free Installation



ZINC SUCCESS STORY: FORT BLISS, TEXAS

Electra Sales, the Bridgeport Sales Representative in North Texas, Oklahoma and New Mexico, became aware of a military refurbishment project at Building IBOTA 1 in Fort Bliss. Realizing the project was specified USA Steel, they contacted

the contractor and explained both the cost and material benefits of Bridgeport's U.S. Made Zinc Die Cast Fittings. With the contractor, they reviewed UL514B and the fact the zinc and die cast fittings pass the same performance testing as steel fittings.

The result: Bridgeport got the order for U.S. Made Product. The bill of material included set screw EMT connectors and couplings, straight and 90 degree flex connectors and combination couplings.

Bottom line: The government uses U.S. Made product and saves money using zinc over steel. And our distributor and sales rep get the order. **Buy American! Buy Bridgeport!**

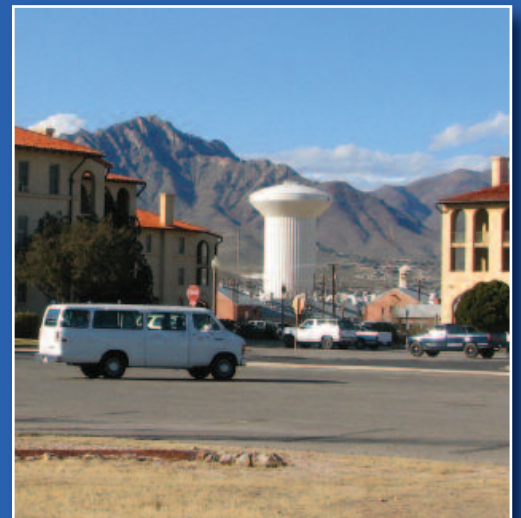

Made in the USA Product - Zinc

Made in the USA Zinc Set Screw Connectors for EMT

Cat. Number	Trade Size	Dim A	Dim B	Dim C
230-DC2*	1/2"	1.13"	0.75"	0.94"
231-DC2*	3/4"	1.44"	1.31"	1.19"
232-DC2*	1"	1.63"	1.06"	1.44"
233-DC2*	1 1/4"	2.00"	1.38"	1.88"
234-DC2*	1 1/2"	2.31"	1.56"	2.06"
235-DC2*	2"	2.56"	1.81"	2.56"
236-DC2*	2 1/2"	3.13"	2.13"	3.25"
237-DC2*	3"	3.35"	2.35"	3.89"
238-DC2*	3 1/2"	3.56"	2.56"	4.50"
239-DC2*	4"	3.69"	2.69"	5.00"

*Change suffix to "-DCI2" for Insulated Version

Description: US Made Zinc Set Screw Connectors

Application: Used to join EMT conduit to a box or enclosure in dry locations

UL Standard: UL-514B

UL File Number: E24001

CSA File Number: LR39354

Federal Specification: A-A-50553

NEMA Standard: FB-1

UNSPC: 39121434

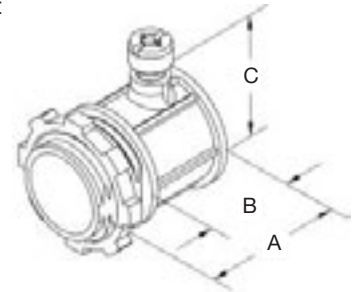

Made in the USA Zinc Set Screw Couplings for EMT

Cat. Number	Trade Size	Dim A	Dim B
240-DC	1/2"	1.50"	0.94"
241-DC	3/4"	1.88"	1.19"
242-DC	1"	2.06"	1.44"
243-DC	1 1/4"	2.50"	1.88"
244-DC	1 1/2"	2.88"	2.08"
245-DC	2"	3.44"	2.50"
246-DC	2 1/2"	4.00"	3.26"
247-DC	3"	4.50"	3.89"
248-DC	3 1/2"	5.00"	4.46"
249-DC	4"	5.25"	4.99"

Description: US Made Zinc Set Screw Couplings

Application: Used to join EMT conduit in dry locations

UL Standard: UL-514B

UL File Number: E24001

CSA File Number: LR39354

Federal Specification: A-A-50553

NEMA Standard: FB-1

UNSPC: 39121434

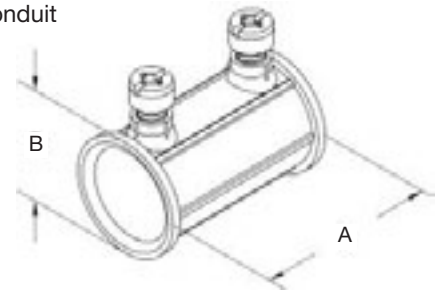

Made in the USA Zinc Compression Connectors for EMT

Cat. Number	Trade Size	Dim A	Dim B	Dim C
250-DC2*	1/2"	0.88"	1.25"	1.08"
251-DC2*	3/4"	0.88"	1.34"	1.44"
252-DC2*	1"	0.94"	1.50"	1.69"
253-DC2*	1 1/4"	1.13"	1.75"	2.18"
254-DC2*	1 1/2"	1.31"	2.00"	2.44"
255-DC2*	2"	1.38"	2.12"	2.94"
256-DC2*	2 1/2"	1.88"	3.00"	3.62"
257-DC2*	3"	2.25"	3.25"	4.25"
258-DC2*	3 1/2"	2.50"	3.50"	4.80"
259-DC2*	4"	2.75"	3.75"	5.25"

*Change suffix to "-DCI2" for Insulated Version

Description: US Made Zinc Compression Connectors

Application: Used to join EMT conduit to a box or enclosure in dry locations or in concrete tight applications

UL Standard: UL-514B

UL File Number: E24001

CSA File Number: LR39354

Federal Specification: A-A-50553

NEMA Standard: FB-1

UNSPC: 39121311

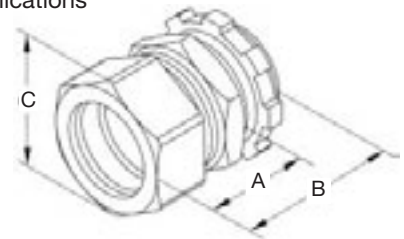

Made in the USA Zinc Set Compression Couplings for EMT

Cat. Number	Trade Size	Dim A	Dim B
260-DC	1/2"	1.38"	1.08"
261-DC	3/4"	1.62"	1.44"
262-DC	1"	1.63"	1.69"
263-DC	1 1/4"	2.06"	2.18"
264-DC	1 1/2"	2.25"	2.44"
265-DC	2"	2.25"	2.94"
266-DC	2 1/2"	3.75"	3.62"
267-DC	3"	4.00"	4.25"
268-DC	3 1/2"	4.19"	4.88"
269-DC	4"	4.75"	5.25"

Description: US Made Zinc Set Compression Couplings

Application: Used to join EMT conduit in dry locations or in concrete tight applications

UL Standard: UL-514B

UL File Number: E24001

CSA File Number: LR39354

Federal Specification: A-A-50553

NEMA Standard: FB-1

UNSPC: 39121311

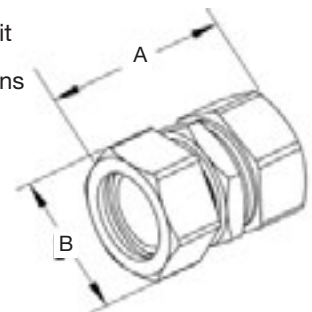

Made in the USA Product - Steel

Made in the USA Steel Set Screw Connectors for EMT

Cat. Number	Trade Size	Dim A	Dim B	Dim C
230-US*	1/2"	1.13"	1.00"	0.38"
231-US*	3/4"	1.25"	1.35"	0.38"
232-US*	1"	1.50"	1.63"	0.50"
233-US*	1 1/4"	1.75"	2.00"	0.50"
234-US*	1 1/2"	1.88"	2.25"	0.50"
235-US*	2"	2.00"	2.75"	0.50"
236-US*	2 1/2"	2.75"	3.75"	1.25"
237-US*	3"	3.06"	4.84"	1.38"
238-US*	3 1/2"	3.18"	5.00"	1.38"
239-US*	4"	3.56"	5.75"	1.50"

*Change suffix to "-USI" for Insulated Version

Description: US Made Steel Set Screw Connectors

Application: Used to join EMT conduit to a box or enclosure in dry locations

UL Standard: UL-514B

cULus File Number: E24001

Federal Specification: A-A-50553

NEMA Standard: FB-1

UNSPC: 39121434

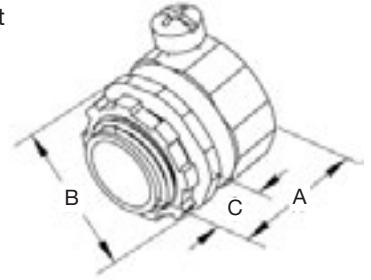

Made in the USA Steel Set Screw Couplings for EMT

Cat. Number	Trade Size	Dim A	Dim B
240-US	1/2"	1.50"	0.88"
241-US	3/4"	1.50"	1.13"
242-US	1"	1.88"	1.38"
243-US	1 1/4"	2.25"	1.75"
244-US	1 1/2"	2.63"	2.13"
245-US	2"	2.75"	2.56"
246-US	2 1/2"	2.75"	3.90"
247-US	3"	3.25"	4.50"
248-US	3 1/2"	3.25"	5.00"
249-US	4"	3.50"	5.75"

Description: US Made Steel Set Screw Couplings

Application: Used to join EMT conduit in dry locations

UL Standard: UL-514B

cULus File Number: E24001

Federal Specification: A-A-50553

NEMA Standard: FB-1

UNSPC: 39121434

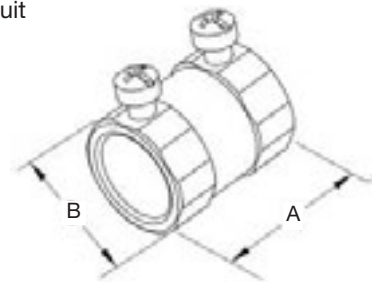

Made in the USA Steel Compression Connectors for EMT

Cat. Number	Trade Size	Dim A	Dim B	Dim C
250-US*	1/2"	1.06"	1.12"	0.38"
251-US*	3/4"	1.25"	1.12"	0.41"
252-US*	1"	1.50"	1.25"	0.44"
253-US*	1 1/4"	2.00"	1.50"	0.50"
254-US*	1 1/2"	2.25"	1.62"	0.56"
255-US*	2"	2.75"	1.75"	0.56"
256-US*	2 1/2"	4.12"	3.62"	1.25"
257-US*	3"	4.65"	4.00"	1.38"
258-US*	3 1/2"	5.20"	4.31"	1.38"
259-US*	4"	5.75"	4.75"	1.50"

*Change suffix to "-USI" for Insulated Version

Description: US Made Steel Compression Connectors

Application: Used to join EMT conduit to a box or enclosure in dry locations or in concrete tight applications

UL Standard: UL-514B

cULus File Number: E24001

Federal Specification: A-A-50553

NEMA Standard: FB-1

UNSPC: 39121311

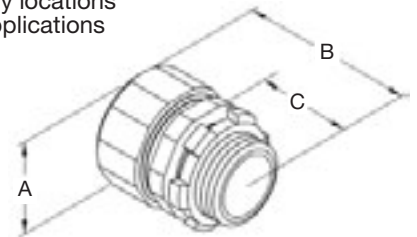

Made in the USA Steel Set Compression Couplings for EMT

Cat. Number	Trade Size	Dim A	Dim B
260-US	1/2"	1.38"	1.00"
261-US	3/4"	1.38"	1.25"
262-US	1"	1.50"	1.62"
263-US	1 1/4"	1.88"	2.00"
264-US	1 1/2"	2.00"	2.25"
265-US	2"	2.12"	2.75"
266-US	2 1/2"	3.32"	3.93"
267-US	3"	5.72"	4.67"
268-US	3 1/2"	6.00"	5.38"
269-US	4"	6.00"	5.75"

Description: US Made Steel Compression Couplings

Application: Used to join EMT conduit in dry locations or in concrete tight applications

UL Standard: UL-514B

cULus File Number: E24001

Federal Specification: A-A-50553

NEMA Standard: FB-1

UNSPC: 39121311

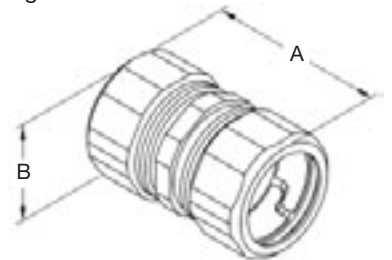

Made in the USA Product - Steel

Made in the USA Steel One Hole EMT Straps

Cat. Number	Trade Size	Dim A	Dim B	Dim C
920-S	1/2"	1.13"	0.63"	0.27"
921-S	3/4"	1.25"	0.63"	0.27"
922-S	1"	1.56"	0.75"	0.31"
923-S	1 1/4"	1.88"	0.88"	0.38"
924-S	1 1/2"	2.50"	1.25"	0.44"
925-S	2"	2.83"	1.25"	0.44"
907-S	2 1/2"	3.38"	1.25"	0.56"
908-S	3"	3.88"	1.25"	0.56"
909-S	3 1/2"	4.13"	1.25"	0.56"
910-S	4"	4.38"	1.25"	0.56"

Description: US Made One Hole Steel Pipe Strap

Application: Used to support EMT to mounting surface

UL Standard: UL-514B

cULus File Number: E161206

Federal Specification: A-A-50553

NEMA Standard: FB-1

UNSPC: 39121434

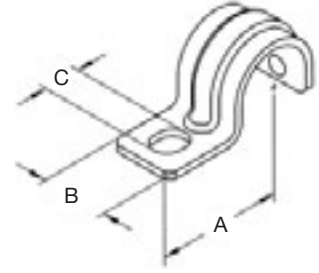

Made in the USA Steel Two Hole EMT Straps

Cat. Number	Trade Size	Dim A	Dim B	Dim C
1920	1/2"	2.13"	0.75"	0.19"
1921	3/4"	2.13"	1.00"	0.19"
1922	1"	2.93"	1.19"	0.19"
1923	1 1/4"	3.62"	1.56"	0.25"
1924	1 1/2"	4.00"	1.75"	0.28"
1925	2"	4.63"	2.25"	0.25"
1907	2 1/2"	6.00"	2.81"	0.38"
1908	3"	6.50"	3.56"	0.38"
1909	3 1/2"	7.50"	4.06"	0.44"
1910	4"	8.00"	4.56"	0.44"

Description: US Made Two Hole Steel Pipe Strap

Application: Used to support EMT to mounting surface

UL Standard: UL-514B

cULus File Number: E161206 (1907 thru 1910)

CSA File Number: LR39354

Federal Specification: A-A-50553

NEMA Standard: FB-1

UNSPC: 39121434

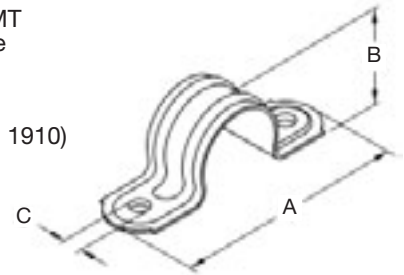

Made in the USA Steel EMT Nail Straps

Cat. Number	Trade Size	Dim A	Dim B
920-NS	1/2"	2.19"	1.06"
921-NS	3/4"	2.31"	1.31"
922-NS	1"	2.38"	1.56"

Description: US Made Steel EMT Nail Strap

Application: Used to support EMT to mounting surface

Federal Specification: A-A-50553

NEMA Standard: FB-1

UNSPC: 39121701

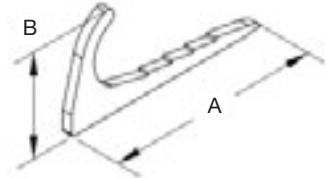

Made in the USA Steel with Bolt and Nut Conduit Hangers

Cat. Number	Trade Size	Dim A	Dim B	Dim C
2100-BN	0	1.94"	0.75"	1.00"
2110-BN	1	2.25"	0.75"	1.00"
2120-BN	2	2.50"	0.88"	1.19"
2125-BN	2 1/2	2.75"	0.88"	1.31"
2130-BN	3	3.00"	0.88"	1.38"
2140-BN	4	3.31"	1.00"	1.63"

Description: US Made Steel Conduit Hangers with Bolt and Nut

Application: Used to secure EMT or rigid conduit to threaded rod, insulator supports, or directly to mounting surface in a vertical or horizontal position

UL Standard: UL-514B

cULus File Number: 161206

Federal Specification: A-A-50553

NEMA Standard: FB-1

UNSPC: 39121434

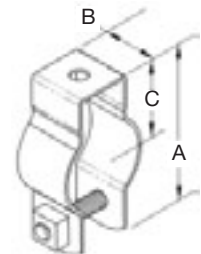

Made in the USA 304 Stainless Steel with Bolt Conduit Hangers

Cat. Number	Trade Size	Dim A	Dim B	Dim C
2100-S	0	1.75"	0.75"	0.88"
2110-S	1	2.13"	0.88"	0.88"
2120-S	2	2.56"	0.88"	1.25"
2125-S	2 1/2	2.88"	0.88"	1.44"
2130-S	3	3.13"	0.88"	1.50"
2140-S	4	3.56"	1.00"	1.56"
2150-S	5	3.88"	1.25"	1.75"
2160-S	6	4.62"	1.25"	2.25"
2170-S	7	5.50"	1.25"	2.62"
2180-S	8	6.00"	1.25"	2.69"
2190-S	9	6.88"	1.25"	3.00"

Description: US Made 304 Stainless Steel Conduit Hangers with Bolt

Application: Used to secure EMT or rigid conduit to threaded rod, insulator supports, or directly to mounting surface in a vertical or horizontal position

Federal Specification: A-A-50553

NEMA Standard: FB-1

UNSPC: 39121434

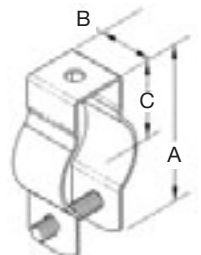

Made in the USA Product - Steel

Made in the USA Steel Set Screw Connectors for Rigid Conduit

Cat. Number	Trade Size	Dim A	Dim B	Dim C
3500-US	1/2"	1.18"	0.80"	1.18"
3501-US	3/4"	1.20"	0.81"	1.40"
3502-US	1"	1.50"	1.00"	1.69"
3503-US	1 1/4"	1.70"	1.20"	2.13"
3504-US	1 1/2"	1.94"	1.38"	2.37"
3505-US	2"	2.00"	1.38"	2.88"

Description: US Made Steel Set Screw Connectors
Application: Used to join unthreaded rigid conduit to a box or enclosure in dry locations
UL Standard: UL-514B
UL File Number: E9391
Federal Specification: A-A-50553
NEMA Standard: FB-1
UNSPC: 39121311

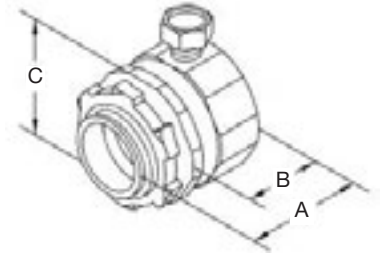

Made in the USA Steel Set Screw Couplings for Rigid Conduit

Cat. Number	Trade Size	Dim A	Dim B
3600-US	1/2"	1.50"	1.18"
3601-US	3/4"	1.50"	1.40"
3602-US	1"	1.88"	1.69"
3603-US	1 1/4"	2.21"	2.13"
3604-US	1 1/2"	2.60"	2.37"
3605-US	2"	2.70"	2.87"

Description: US Made Steel Set Screw Couplings
Application: Used to join unthreaded rigid conduit in dry locations
UL Standard: UL-514B
UL File Number: E9391
Federal Specification: A-A-50553
NEMA Standard: FB-1
UNSPC: 39121311

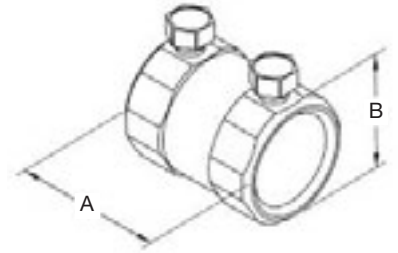

Made in the USA Steel Compression Connectors for Rigid Conduit

Cat. Number	Trade Size	Dim A	Dim B	Dim C
3000-US	1/2"	0.88"	1.38"	1.18"
3001-US	3/4"	0.96"	1.50"	1.43"
3002-US	1"	1.00"	1.68"	1.75"
3003-US	1 1/4"	1.30"	1.97"	2.15"
3004-US	1 1/2"	1.38"	2.13"	2.37"
3005-US	2"	1.50"	2.25"	2.88"

Description: US Made Steel Compression Connectors
Application: Used to join unthreaded rigid conduit to a box or enclosure in dry locations or in concrete tight applications
UL Standard: UL-514B
UL File Number: E9391
Federal Specification: A-A-50553
NEMA Standard: FB-1
UNSPC: 39121311

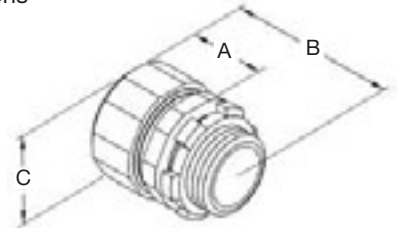

Made in the USA Steel Set Compression Couplings for Rigid Conduit

Cat. Number	Trade Size	Dim A	Dim B
3100-US	1/2"	1.75"	1.18"
3101-US	3/4"	1.94"	1.43"
3102-US	1"	2.13"	1.75"
3103-US	1 1/4"	2.50"	2.15"
3104-US	1 1/2"	2.80"	2.37"
3105-US	2"	2.80"	2.88"

Description: US Made Steel Compression Couplings
Application: Used to join unthreaded rigid conduit in dry locations or in concrete tight applications
UL Standard: UL-514B
UL File Number: E9391
Federal Specification: A-A-50553
NEMA Standard: FB-1
UNSPC: 39121311

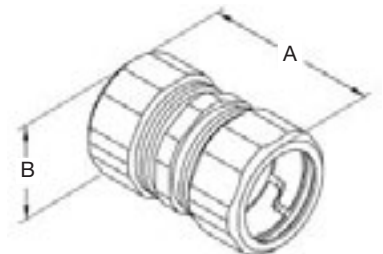

Bridgeport Fittings, Inc.
 705 Lordship Blvd.
 Stratford, CT 06615-7313

Voice: 203.377.5944
Fax: 203.381.3488
E-mail: sales@bptfittings.com

