



14 SEER HEAT PUMP ENVIRONMENTALLY SOUND R-410A REFRIGERANT 1½ THRU 5 TONS SPLIT SYSTEM 208 / 230 Volt, 1-phase, 60 Hz

REFRIGERATION CIRCUIT

- Scroll compressors on all models
- Suction line accumulator factory installed
- Bi-flow filter-drier included for field installation
- Integrated solid state control with Time-Temperature Defrost
- High and Low pressure switches
- Copper tube / aluminum fin coil

EASY TO INSTALL AND SERVICE

- Easy Access service valves on all models
- External high and low refrigerant service ports
- Only two screws to access control panel
- Factory charged with R-410A refrigerant

BUILT TO LAST

- Baked-on powder coat finish over galvanized steel
- Post-painted (black) coil fins
- Coated, weather-resistant cabinet screws
- Coated inlet grille with 3/8 (10mm) grille spacing for extra protection

WARRANTY*

- 5 year parts limited warranty (including compressor and coil)
 - With timely registration, an additional 5 year parts limited warranty (including compressor and coil)

* For residential applications only. See warranty certificate for complete details and restrictions, including warranty coverage for other applications.



Use of the AHRI Certified TM Mark indicates a manufacturer's participation in the program. For verification of certification for individual products, go to www.ahridirectory.org.



Model Number	Size (tons)	Nominal Btu/hr	Min. Circuit Ampacity	Max. Fuse or Breaker	Operating Dimensions length x width x height inches (mm)	Operating/Ship Weight lbs. (kg)
N4H418GKG	1½	18,000	11.8	20	23-1/8 x 23-1/8 x 35-3/4 (587 x 587 x 895)	136 / 166 (61 / 75)
N4H424GKG	2	24,000	14.2	25	25-3/4 x 25-3/4 x 35-3/4 (654 x 654 x 895)	144 / 175 (65 / 79)
N4H430GKG	2½	30,000	18.3	30	31-3/16 x 31-3/16 x 31-13/16 (792 x 792 x 808)	158 / 180 (72 / 82)
N4H436GKG	3	36,000	20.0	30	31-3/16 x 31-3/16 x 28-7/16 (792 x 792 x 722)	170 / 201 (77 / 91)
N4H442GKG	3½	42,000	24.0	40	31-3/16 x 31-3/16 x 39-1/8 (792 x 792 x 994)	201 / 235 (91 / 107)
N4H448GKG	4	48,000	25.2	40	31-3/16 x 31-3/16 x 28-7/16 (792 x 792 x 722)	197 / 232 (89 / 105)
N4H460GKG	5	60,000	32.0	50	31-3/16 x 31-3/16 x 31-13/16 (792 x 792 x 808)	212 / 248 (96 / 113)

OUTDOOR UNIT MODEL NUMBER IDENTIFICATION GUIDE (single phase)											
Digit Position:	1	2	3	4	5, 6	7	8	9	10	11	12
Example Part Number:	N	4	H	4	18	G	K	G	1	0	0
T = Tempstar Mainline											
N = Tempstar Entry BRANDING											
2 = R-22											
4 = R-410A REFRIGERANT											
A = Air Conditioner											
H = Heat Pump TYPE											
4 = 14 SEER NOMINAL EFFICIENCY											
18 = 18,000 BTUH = 1½ tons											
24 = 24,000 BTUH = 2 tons											
30 = 30,000 BTUH = 2½ tons											
36 = 36,000 BTUH = 3 tons											
42 = 42,000 BTUH = 3½ tons											
48 = 48,000 BTUH = 4 tons											
60 = 60,000 BTUH = 5 tons NOMINAL CAPACITY											
A = Standard Grille, 2" (51mm) spacing											
G = Coil Guard Grille, 3/8 (10mm) spacing FEATURES											
K = 208/230-1-60 VOLTAGE											
Sales Code											
Engineering Revision											
Extra Digit											
Extra Digit											

ACCESSORIES PART NUMBER IDENTIFICATION GUIDE									
Digit Position:	1	2	3	4	5	6, 7	8, 9	10, 11	
Example Part Number:	N	A	S	A	0	01	01	CH	
N = Non-Branded BRANDING									
A = Accessory PRODUCT GROUP									
S = Split System (AC & HP) KIT USAGE									
A = Original									
B = 2nd Generation MAJOR SERIES									
0 = Generic or Not Applicable									
2 = R-22									
4 = R-410A REFRIGERANT									
Product Identifier Number									
Package Quantity									
Type of Kit(Example: CH = Crankcase Heater)									

PHYSICAL DATA

UNIT SIZE SERIES	18GKG	24GKG	30GKG	36GKG	42GKG	48GKG	60GKG
Compressor Type	Scroll						
REFRIGERANT	R-410A						
Control	TXV (R-410A Hard Shutoff)						
Charge lb (kg)	5.3 (2.4)	5.6 (2.5)	6.4 (2.9)	7.67 (3.48)	8.25 (3.74)	8.68 (3.94)	10.6 (4.81)
COND FAN	Forward Swept or Propeller Type, Direct Drive						
Air Discharge	Vertical						
Motor HP	1/12	1/10	1/4	1/5	1/4	1/4	1/4
Motor RPM	1100	1100	1100	1100	1100	1100	800
VALVE CONNECT. (In. ID)							
Vapor	5/8	5/8	3/4	3/4	7/8	7/8	7/8
Liquid	3/8						
REFRIGERANT TUBES* (In. OD)							
Rated Vapor	5/8	5/8	3/4	3/4	7/8	7/8	1-1/8
Max Liquid Line	3/8						

*Units are rated with 25 ft (7.6 m) of lineset length. See Vapor Line Sizing and Cooling Capacity Loss table when using other sizes and lengths of lineset.

Note: See unit Installation Instruction for proper installation.

ELECTRICAL DATA

UNIT SIZE	V/PH	OPER VOLTS*		COMPR		FAN	MCA	MAX FUSE** or CKT BRK AMPS
		MAX	MIN	LRA	RLA	FLA		
18	208/230/1	253	197	48.0	9.0	0.50	11.8	20
24				62.9	10.9	0.60	14.2	25
30				72.5	13.5	1.40	18.3	30
36				75.0	15.1	1.10	20.0	30
42				105.5	18.1	1.40	24.0	40
48				108.0	19.0	1.40	25.2	40
60				144.2	24.4	1.52	32.0	50

* Permissible limits of the voltage range at which the unit will operate satisfactorily

** Time-Delay fuse.

FLA - Full Load Amps

LRA - Locked Rotor Amps

MCA - Minimum Circuit Amps

RLA - Rated Load Amps

NOTE: Control circuit is 24-V on all units and requires external power source. Copper wire must be used from service disconnect to unit.

All motors/compressors contain internal overload protection.

Complies with 2007 requirements of ASHRAE Standards 90.1

A-WEIGHTED SOUND POWER

UNIT SIZE	STANDARD RATING (dBA)	TYPICAL OCTAVE BAND SPECTRUM (dBA, without tone adjustment)						
		125	250	500	1000	2000	4000	8000
18	69	45	48	56	62	55	53	47
24	76	46	56	59	63	63	60	55
30	77	52	62	67	68	65	62	55
36	77	51	62	66	69	64	61	53
42	76	49	61	63	65	62	60	52
48	79	53	66	69	71	67	64	57
60	73	50	63	62	63	60	58	52

NOTE: Tested in accordance with AHRI Standard 270-08 (not listed in AHRI).

A-WEIGHTED SOUND POWER WITH SOUND HOOD

UNIT SIZE	STANDARD RATING	TYPICAL OCTAVE BAND SPECTRUM (dBA, without tone adjustment)						
		125	250	500	1000	2000	4000	8000
18	68	47	48	56	61	55	52	46
24	74	47	57	59	62	61	58	51
30	77	52	62	67	67	65	62	54
36	76	52	62	66	67	64	60	52
42	74	50	61	63	64	61	58	49
48	79	54	66	69	70	67	64	56
60	73	51	64	62	63	59	56	49

NOTE: Tested in accordance with AHRI Standard 270-08 (not listed in AHRI).

CHARGING SUBCOOLING (TXV-TYPE EXPANSION DEVICE)

UNIT SIZE-SERIES	REQUIRED SUBCOOLING °F (°C)
18	11 (6.1)
24	11 (6.1)
30	10 (5.6)
36	10 (5.6)
42	10 (5.6)
48	14 (7.7)
60	15 (8.3)

HP ONLY REPLACEMENT WITH PISTON INDOORS

When the N4H4 is used as a replacement component in a system with a piston fan coil, use the indoor piston size specified below:

UNIT SIZE	PISTON SIZE		
	FEM4P	FMA4	FM(C,U)4P
18	0.052	0.050	0.050
24	0.057	0.057	0.056
30	0.067	0.070	0.067
36	0.070	0.072	0.069
42	0.078		
48	0.084		
60			

VAPOR LINE SIZING AND COOLING CAPACITY LOSS

Acceptable vapor line diameters provide adequate oil return to the compressor while avoiding excessive capacity loss. The suction line diameters shown in the chart below are acceptable for HP systems with R-410A refrigerant:

Vapor Line Sizing and Cooling Capacity Losses – R-410A Refrigerant 1- Stage Heat Pump Applications

Unit Nominal Size (Btuh)	Acceptable Vapor Line Diameters (In. OD)	Cooling Capacity Loss (%) Total Equivalent Line Length (ft)											
		Standard Application			Long Line Application Requires Accessories								
		25 (7.62)	50 (15.2)	80 (24.4)	80+ (24.4+)	100 (30.48)	125 (38.10)	150 (45.72)	175 (53.34)	200 (60.96)	225 (68.58)	250 (76.20)	
18000 1-Stage HP	1/2	1	2	3	3	4	6	7	8	9	10	12	
	5/8	0	0	1	1	1	1	2	2	3	3	3	
24000 1-Stage HP	5/8	0	1	1	1	2	3	3	4	4	5	6	
	3/4	0	0	0	0	0	1	1	1	1	1	2	
30000 1-Stage HP	5/8	1	2	3	3	3	4	5	6	7	8	9	
	3/4	0	0	1	1	1	1	2	2	2	3	3	
	7/8	0	0	0	0	0	1	1	1	1	1	1	
36000 1-Stage HP	5/8	1	2	4	4	5	6	7	9	10	11	13	
	3/4	0	0	1	1	1	2	2	3	3	4	4	
	7/8	0	0	0	0	0	1	1	1	1	2	2	
42000 1-Stage HP	3/4	0	1	2	2	2	3	4	4	5	6	6	
	7/8	0	0	1	1	1	1	2	2	2	3	3	
48000 1-Stage HP	3/4	0	1	2	2	3	4	5	5	6	7	8	
	7/8	0	0	1	1	1	2	2	2	3	3	4	
60000 1-Stage R-410A HP	3/4	1	2	4	4	5	6	7	9	10	11	12	
	7/8	0	1	2	2	2	3	4	4	5	5	6	
	1 1/8	0	0	0	0	1	1	1	1	1	1	2	

Standard Length = 80 ft. (24.4 m) or less total equivalent length

Applications in this area are long line. Accessories are required as shown recommended on Long Line Application Guidelines

Applications in this area may have height restrictions that limit allowable total equivalent length, when outdoor unit is below indoor unit See Long Line Application Guidelines

REFRIGERANT PIPING LENGTH LIMITATIONS

Maximum Line Lengths:

The maximum allowable total equivalent length for heat pumps varies depending on the vertical separation. See the tables below for allowable lengths depending on whether the outdoor unit is on the same level, above or below the outdoor unit.

Maximum Line Lengths for Heat Pump Applications

	MAXIMUM ACTUAL LENGTH ft (m)	MAXIMUM EQUIVALENT LENGTH† ft (m)	MAXIMUM VERTICAL SEPARATION ft (m)
Units on equal level	200 (61)	250 (76.2)	N/A
Outdoor unit ABOVE indoor unit	200 (61)	250 (76.2)	200 (61)
Outdoor unit BELOW indoor unit	See Table 'Maximum Total Equivalent Length: Outdoor Unit BELOW Indoor Unit'		

† Total equivalent length accounts for losses due to elbows or fitting. See the Long Line Guideline for details.

Maximum Total Equivalent Length† – Outdoor Unit BELOW Indoor Unit

Size	Liquid Line Diameter w/ TXV	HP with R-410A Refrigerant – Maximum Total Equivalent Length† Vertical Separation ft (m) Outdoor unit BELOW indoor unit;						
		0–20 (0 – 6.1)	21–30 (6.4 – 9.1)	31–40 (9.4 – 12.2)	41–50 (12.5 – 15.2)	51–60 (15.5 – 18.3)	61–70 (18.6 – 21.3)	71–80 (21.6 – 24.4)
18000 HP with R-410A	3/8	250*	250*	250*	250*	250*	250*	250*
24000 HP with R-410A	3/8	250*	250*	250*	250*	250*	250*	250*
30000 HP with R-410A	3/8	250*	250*	250*	250*	250*	250*	250*
36000 HP with R-410A	3/8	250*	250*	250*	250*	250*	250*	250*
42000 HP with R-410A	3/8	250*	250*	250*	250*	250*	250*	150
48000 HP with R-410A	3/8	250*	250*	250*	250*	230	160	--
60000 HP with R-410A	3/8	250*	225*	190	150	110	--	--

* Maximum actual length not to exceed 200 ft (61 m)

† Total equivalent length accounts for losses due to elbows or fitting. See the Long Line Guideline for details.

-- = outside acceptable range

LONG LINE APPLICATIONS

An application is considered Long Line when the refrigerant level in the system requires the use of accessories to maintain acceptable refrigerant management for systems reliability. Defining a system as long line depends on the liquid line diameter, actual length of the tubing, and vertical separation between the indoor and outdoor units.

For Heat Pump systems, the chart below shows when an application is considered Long Line. Beyond these lengths, long line accessories are required:

HP WITH R-410A REFRIGERANT LONG LINE DESCRIPTION ft (m)
Beyond these lengths, long line accessories are required

Liquid Line Size	Units On Same Level	Outdoor Below Indoor	Outdoor Above Indoor
3/8	80 (24.4)	20 (6.1) vertical or 80 (24.4) total	80 (24.4)

Note: See Long Line Guideline for details

Model Number	Indoor Coil Model Number	Cooling Capacity	EER	SEER	High Temp		HSPF	Low Temp	
					E Capacity	E COP		H Capacity	H COP
N4H418GKG	FEM4X18**BL	17,800	11.7	14	17,600	3.72	8.2	10,400	2.40
N4H424GKG	FEM4X24**CL	22,200	11.5	14	22,200	3.84	8.2	13,200	2.54
N4H430GKG	FEM4X30**BL	28,600	11.7	14	28,600	3.62	8.2	17,100	2.44
N4H436GKG	FEM4X36**BL	33,000	11.7	14	33,800	3.62	8.2	21,000	2.40
N4H442GKG	FEM4X42**BL	40,000	11.5	14	41,000	3.62	8.2	25,200	2.50
N4H448GKG	FEM4X48**BL	46,000	11.7	14	45,500	3.64	8.2	27,800	2.56
N4H460GKG	FXM4X60**AL	57,000	11.7	14	54,500	3.70	8.2	33,000	2.56

* AHRI = Air Conditioning, Heating & Refrigeration Institute

* Ratings are net values reflecting the effects of circulating fan heat. Supplemental electric heat is not included. Ratings are based on:

Cooling Standard: 80°F (27°C) db 67°F (19°C) wb indoor entering air temperature and 95°F (35°C) db air entering outdoor unit.

High-Temp Heating Standard: 70°F (21°C) db indoor entering air temperature and 47°F (8°C) db 43°F (6°C) wb air entering outdoor unit.

Low-Temp Heating Standard: 70°F (21°C) db indoor entering air temperature and 17°F (-9°C) db 15°F (-9°C) wb air entering outdoor unit.

COP — Coefficient of Performance

EER — Energy Efficiency Ratio

HSPF — Heating Seasonal Performance Factor

SEER — Seasonal Energy Efficiency Ratio

TESTED AHRI COMBINATION RATINGS*

NOTE: Ratings contained in this document are subject to change at any time.

For AHRI ratings certificates, please refer to the AHRI directory. www.ahridirectory.org

Additional ratings and system combinations can be accessed via the Tempstar database:

<http://www.icpeqp.com/AHRIratings/ratings.aspx?Brand=Tempstar>

Or scan this QR code:



DIMENSIONS - ENGLISH

UNIT	SERIES	ELECTRICAL CHARACTERISTICS	A	B	C	D	E	F	G	K	L	M	N	P	OPERATING WEIGHT(lbs)	SHIPPING WEIGHT(lbs)	SHIPPING DIMENSIONS (L x W x H)
N4H18	1	X 0 0 0	23 1/8"	35 3/4"	3 3/4"	5/8"	4 7/16"	18 1/16"	7 13/16"	2 13/16"	1/2"	11"	15 3/4"	12"	136	166	25 1/4" X 25 1/4" X 40"
N4H24	1	X 0 0 0	25 3/4"	35 3/4"	3 3/4"	5/8"	4 7/16"	21 1/4"	9 1/8"	2 13/16"	1/2"	12"	13 1/4"	13 1/2"	144	175	27 7/8" X 27 7/8" X 40"
N4H30	1	X 0 0 0	31 3/16"	31 13/16"	3 3/4"	3/4"	6 9/16"	24 11/16"	9 1/8"	2 15/16"	5/8"	15"	11"	16"	158	180	33 3/8" X 33 3/8" X 36 5/8"
N4H36	2	X 0 0 0	31 3/16"	28 7/16"	3 3/4"	3/4"	6 9/16"	24 11/16"	9 1/8"	2 15/16"	5/8"	15 3/4"	14"	10 3/4"	170	201	33 3/8" X 33 3/8" X 33 1/4"
N4H42	1	X 0 0 0	31 3/16"	39 1/8"	3 7/8"	7/8"	6 9/16"	24 11/16"	9 1/8"	2 15/16"	5/8"	15 1/2"	13 1/2"	14"	201	235	33 3/8" X 33 3/8" X 43 1/2"
N4H48	1	X 0 0 0	31 3/16"	28 1/16"	3 7/8"	7/8"	6 9/16"	24 11/16"	9 1/8"	2 15/16"	5/8"	16 1/2"	11 1/2"	15"	197	232	33 3/8" X 33 3/8" X 33 1/4"
N4H460	1	X 0 0 0	31 3/16"	31 13/16"	3 7/8"	7/8"	6 9/16"	24 11/16"	9 1/8"	2 15/16"	5/8"	14 3/4"	15 3/4"	16 1/4"	212	248	33 3/8" X 33 3/8" X 36 5/8"

- NOTES:
- ALLOW 30" CLEARANCE TO SERVICE SIDE OF UNIT. 48" ABOVE UNIT, 6" ON ONE SIDE, 12" ON REMAINING SIDE, AND 24" BETWEEN UNITS FOR PROPER AIRFLOW.
 - MINIMUM OUTDOOR OPERATING AMBIENT IN COOLING MODE IS 55°F, MAX. 125°F.
 - SERIES DESIGNATION IS THE 10TH POSITION OF THE UNIT MODEL NUMBER.
 - CENTER OF GRAVITY
 - ALL DIMENSIONS ARE IN "INCHES" UNLESS NOTED.

UNIT SIZE	"X" MIN GROUND MOUNTING PAD APPLICATION DIMENSIONS	"Y" MIN ROOF-TOP MOUNTING PAD APPLICATION DIMENSIONS
18	23 1/8"	17 3/4"
24	25 3/4"	20 7/16"
30,36,42,48,60	31 3/16"	23"
-	35"	26 3/4"

X = YES
O = NO

208-230-1-60	230-1-60	208/230-3-60	460-3-60
--------------	----------	--------------	----------

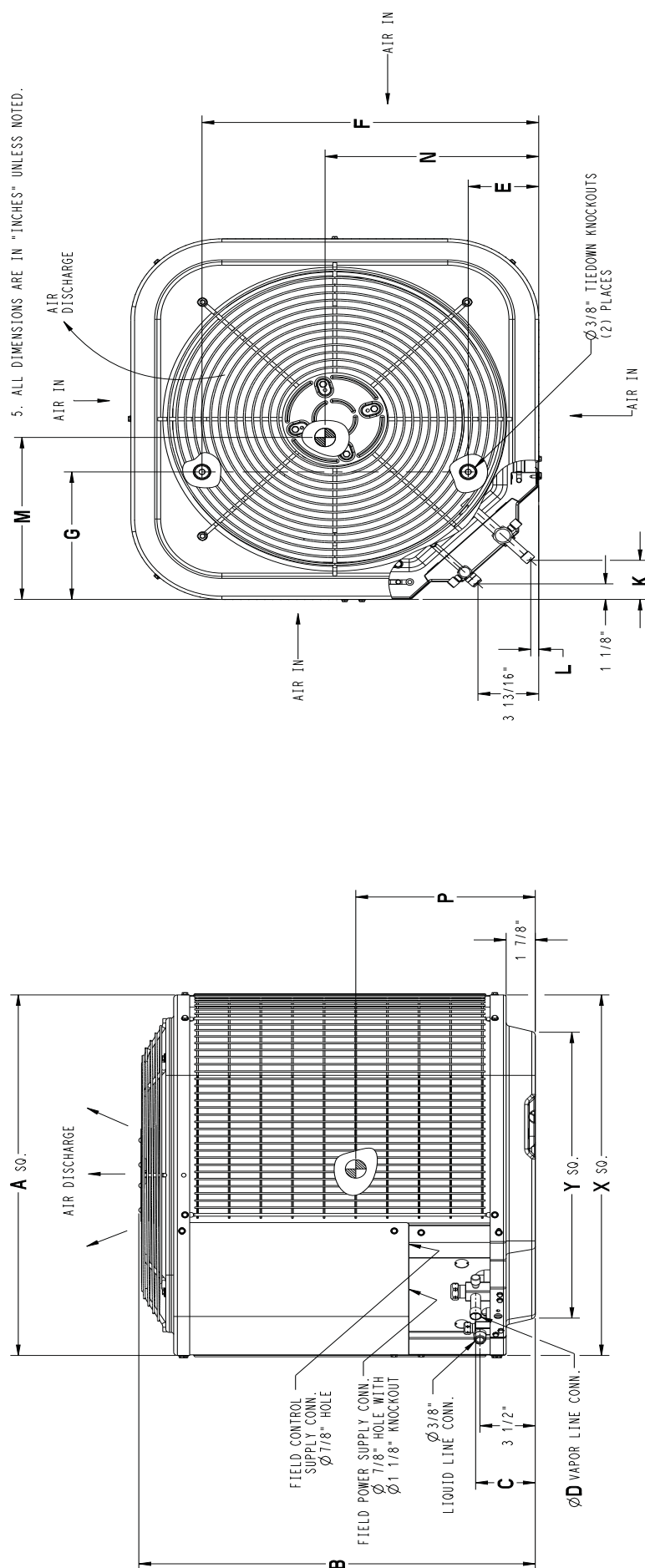

DIMENSIONS - SI

UNIT	SERIES	ELECTRICAL CHARACTERISTICS	A	B	C	D	E	F	G	K	L	M	N	P	OPERATING WEIGHT(Kgs)	SHIPPING WEIGHT(Kgs)	SHIPPING DIMENSIONS (L x W x H)
N4H418	1	X 0 0 0	587.4	895.4	95.2	15.9	112.7	458.8	198.4	71.4	12.7	279.4	400.1	304.8	61.7	75.3	641.5 X 641.5 X 1016.9
N4H424	1	X 0 0 0	654.0	895.4	95.2	15.9	112.7	539.8	231.8	71.4	12.7	304.8	336.6	342.9	65.3	79.4	708.0 X 708.0 X 1016.9
N4H430	1	X 0 0 0	792.2	808.0	95.2	19.0	166.7	671.1	231.8	74.6	15.9	381.0	279.4	406.4	71.7	81.6	846.6 X 846.6 X 930.6
N4H436	2	X 0 0 0	792.2	722.3	95.2	19.0	166.7	671.1	231.8	74.6	15.9	400.1	355.6	273.1	77.1	77.1	846.6 X 846.6 X 844.2
N4H442	1	X 0 0 0	792.2	993.8	98.4	22.2	166.7	627.1	231.8	74.6	15.9	393.7	342.9	355.6	91.2	106.6	846.6 X 846.6 X 1103.3
N4H448	1	X 0 0 0	792.2	722.3	98.4	22.2	166.7	627.1	231.8	74.6	15.9	419.1	292.1	381.0	89.4	105.2	846.6 X 846.6 X 844.2
N4H460	1	X 0 0 0	792.2	808.0	98.4	22.2	166.7	627.1	231.8	74.6	15.9	374.7	400.1	412.8	96.2	112.5	846.6 X 846.6 X 930.6

UNIT SIZE	"X" MIN GROUND MOUNTING PAD APPLICATION DIMENSIONS	"Y" MIN ROOF-TOP MOUNTING PAD APPLICATION DIMENSIONS
18	587.4	451.3
24	654.0	518.5
30, 36, 42, 48, 60	792.2	583.2
	889.0	679.7

X = YES
O = NO

NOTES:

- ALLOW 762.0 CLEARANCE TO SERVICE SIDE OF UNIT, 1219.2 ABOVE UNIT, 152.4 ON ONE SIDE, 304.8 ON REMAINING SIDE, AND 609.6 BETWEEN UNITS FOR PROPER AIRFLOW.
- MINIMUM OUTDOOR OPERATING AMBIENT IN COOLING MODE IS 13°C, MAX. 52°C.
- SERIES DESIGNATION IS THE 10TH POSITION OF THE UNIT MODEL NUMBER.
- CENTER OF GRAVITY
- ALL DIMENSIONS ARE IN "MM" UNLESS NOTED.

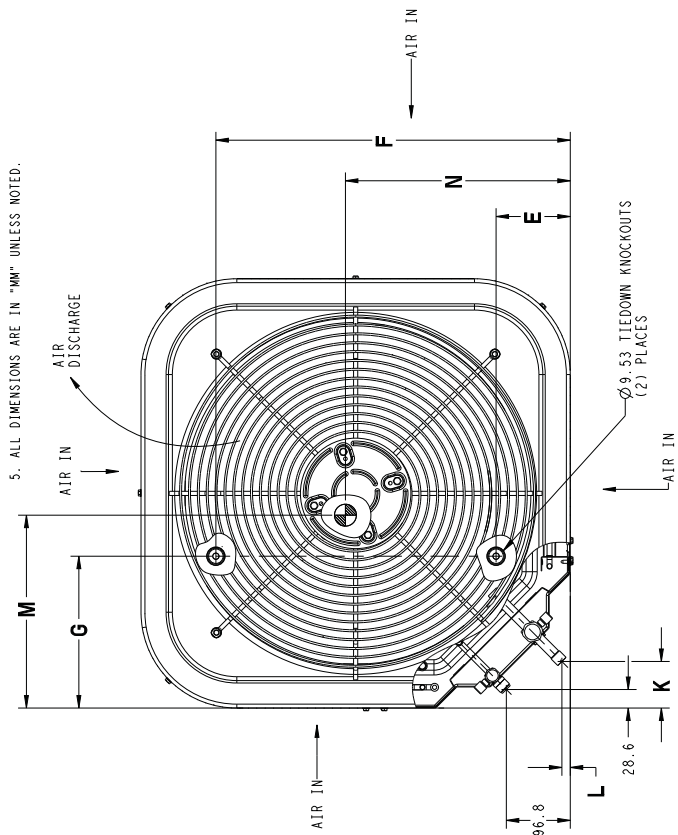
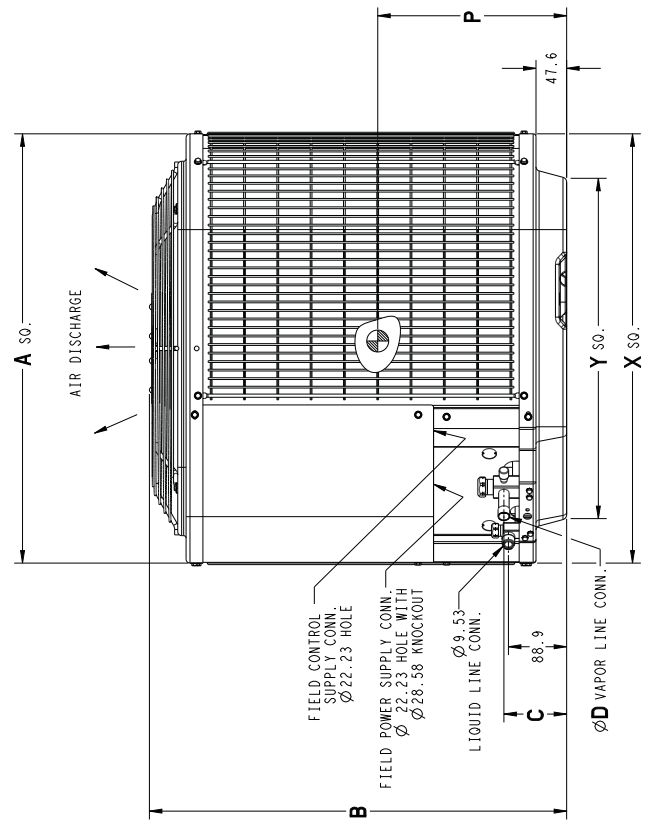

DETAILED COOLING CAPACITIES#

EVAPORATOR AIR		CONDENSER ENTERING AIR TEMPERATURES °F (°C)											
CFM	EWB °F (°C)	75 (23.9)		85 (29.4)		95 (35)		105 (40.6)		115 (46.1)		125 (51.7)	
		Capacity MBtuh	Total System KW**	Capacity MBtuh	Total System KW**	Capacity MBtuh	Total System KW**	Capacity MBtuh	Total System KW**	Capacity MBtuh	Total System KW**	Capacity MBtuh	Total System KW**
		Total	Sensit	Total	Sensit	Total	Sensit	Total	Sensit	Total	Sensit	Total	Sensit
N4H418 Outdoor Section With FEM4X18**BL Indoor Section													
525	72 (22.2)	21.43	10.44	20.38	10.06	19.27	9.66	18.10	9.26	16.86	8.83	15.56	8.39
	67 (19.4)	19.44	12.77	18.48	12.39	17.47	11.99	16.40	11.58	15.26	11.15	14.06	10.69
	63 (17.2)††	17.99	12.27	17.10	11.90	16.16	11.50	15.16	11.08	14.10	10.65	12.98	10.19
	62 (16.7)	17.64	15.03	16.78	14.84	15.88	14.22	14.93	13.76	14.00	14.00	13.10	13.10
	57 (13.9)	16.97	16.97	16.30	16.30	15.58	15.58	14.81	14.81	13.98	13.98	13.08	13.08
	72 (22.2)	21.88	10.96	20.77	10.58	19.62	10.18	18.40	9.76	17.12	9.33	15.77	8.88
	67 (19.4)	19.86	13.61	18.86	13.22	17.80	12.82	16.69	12.39	15.51	11.95	14.27	11.48
	63 (17.2)††	18.40	13.06	17.47	12.87	16.49	14.34	15.44	11.84	14.34	11.39	13.19	10.92
	62 (16.7)	18.08	16.13	17.20	15.71	16.27	16.27	15.43	15.43	14.54	14.54	13.59	13.59
	57 (13.9)	17.73	17.73	17.01	17.01	16.24	16.24	15.41	15.41	14.52	14.52	13.57	13.57
	72 (22.2)	22.22	11.46	21.08	11.07	19.88	10.66	18.63	10.24	17.31	9.80	15.92	9.35
	67 (19.4)	20.71	14.41	19.15	14.01	18.06	13.60	16.91	13.16	15.70	12.71	14.44	12.22
	63 (17.2)††	18.71	13.81	17.75	13.41	16.74	12.99	15.66	12.55	14.53	12.09	13.35	11.59
	62 (16.7)	18.48	17.11	17.63	17.63	16.80	16.80	15.93	15.93	14.99	14.99	13.99	13.99
	57 (13.9)	18.36	18.36	17.60	17.60	16.78	16.78	15.91	15.91	14.97	14.97	13.97	13.97

EVAPORATOR AIR		CONDENSER ENTERING AIR TEMPERATURES °F (°C)											
CFM	EWB °F (°C)	75 (23.9)		85 (29.4)		95 (35)		105 (40.6)		115 (46.1)		125 (51.7)	
		Capacity MBtuh	Total System KW**	Capacity MBtuh	Total System KW**	Capacity MBtuh	Total System KW**	Capacity MBtuh	Total System KW**	Capacity MBtuh	Total System KW**	Capacity MBtuh	Total System KW**
		Total	Sensit	Total	Sensit	Total	Sensit	Total	Sensit	Total	Sensit	Total	Sensit
N4H424 Outdoor Section With FEM4X24**CL Indoor Section													
700	72 (22.2)	26.47	13.51	25.28	13.08	24.03	12.62	22.72	12.15	21.30	11.65	19.77	11.11
	67 (19.4)	24.06	16.68	22.96	16.24	21.82	15.78	20.62	15.31	19.33	14.80	17.93	14.25
	63 (17.2)††	22.32	16.04	21.30	15.60	20.23	15.14	19.11	14.66	17.91	14.15	16.62	13.60
	62 (16.7)	21.92	19.75	20.94	19.28	19.93	18.78	18.88	18.81	17.88	17.88	16.83	16.83
	57 (13.9)	21.31	21.31	20.52	20.52	19.70	19.70	18.81	18.81	17.86	17.86	16.81	16.81
	72 (22.2)	26.97	14.20	25.73	13.76	24.44	13.30	23.07	12.82	21.60	12.31	20.01	11.76
	67 (19.4)	24.53	17.79	23.38	17.34	22.20	16.87	20.95	16.38	19.61	15.86	18.18	15.29
	63 (17.2)††	22.77	17.07	21.70	16.62	20.60	16.15	19.43	15.65	18.19	15.13	16.86	14.56
	62 (16.7)	22.45	21.17	21.45	21.27	20.50	20.50	19.55	19.55	18.53	18.53	17.41	17.41
	57 (13.9)	22.20	22.20	21.35	21.35	20.47	20.47	19.53	19.53	18.51	18.51	17.39	17.39
	72 (22.2)	27.35	14.86	26.08	14.41	24.73	13.94	23.33	13.46	21.82	12.94	20.18	12.38
	67 (19.4)	24.89	18.05	23.71	18.38	22.49	17.80	21.20	17.40	19.84	16.86	18.37	16.26
	63 (17.2)††	23.12	18.85	22.02	17.59	20.88	17.10	19.68	16.59	18.41	16.05	17.05	15.45
	62 (16.7)	22.97	22.97	22.08	22.08	21.14	21.14	20.14	20.14	19.07	19.07	17.88	17.88
	57 (13.9)	22.94	22.94	22.05	22.05	21.11	21.11	20.12	20.12	19.04	19.04	17.86	17.86

EVAPORATOR AIR		CONDENSER ENTERING AIR TEMPERATURES °F (°C)											
CFM	EWB °F (°C)	75 (23.9)		85 (29.4)		95 (35)		105 (40.6)		115 (46.1)		125 (51.7)	
		Capacity MBtuh	Total System KW**	Capacity MBtuh	Total System KW**	Capacity MBtuh	Total System KW**	Capacity MBtuh	Total System KW**	Capacity MBtuh	Total System KW**	Capacity MBtuh	Total System KW**
		Total	Sensit	Total	Sensit	Total	Sensit	Total	Sensit	Total	Sensit	Total	Sensit
N4H430 Outdoor Section With FEM4X30**BL Indoor Section													
875	72 (22.2)	33.97	17.32	32.47	16.75	30.87	16.16	29.15	15.54	27.30	14.87	25.29	14.15
	67 (19.4)	30.80	21.30	29.42	20.72	27.96	20.13	26.39	19.50	24.69	18.82	22.86	18.10
	63 (17.2)††	28.51	20.46	27.22	19.89	25.86	19.29	24.39	18.66	22.82	17.98	21.12	17.25
	62 (16.7)	27.99	25.15	26.74	24.55	25.44	23.90	24.07	23.17	22.67	22.67	21.30	21.30
	57 (13.9)	27.05	27.05	26.06	26.06	25.01	25.01	23.88	23.88	22.64	22.64	21.27	21.27
	72 (22.2)	34.85	18.48	33.25	17.90	31.57	17.30	29.76	16.66	27.81	15.97	25.71	15.24
	67 (19.4)	31.61	23.17	30.15	22.59	28.60	21.97	26.95	21.32	25.18	20.61	23.27	19.84
	63 (17.2)††	29.28	22.21	27.91	21.62	26.47	21.00	24.94	20.34	23.29	19.63	21.52	18.86
	62 (16.7)	28.88	27.53	27.48	27.37	26.36	26.36	25.12	25.12	23.77	23.77	22.28	22.28
	57 (13.9)	28.55	28.55	27.48	27.48	26.33	26.33	25.09	25.09	23.74	23.74	22.26	22.26
	72 (22.2)	35.15	18.97	33.53	18.39	31.81	17.78	29.96	17.13	27.99	16.44	25.85	15.70
	67 (19.4)	31.89	23.94	30.39	23.37	28.82	22.74	26.92	21.71	25.34	21.35	23.41	20.56
	63 (17.2)††	29.55	22.94	28.15	22.84	26.69	21.71	25.12	21.03	23.45	20.30	21.66	19.51
	62 (16.7)	29.18	29.18	28.02	28.02	26.83	26.83	25.55	25.55	24.15	24.15	22.63	22.63
	57 (13.9)	29.10	29.10	27.98	27.98	26.80	26.80	25.52	25.52	24.13	24.13	22.60	22.60

DETAILED COOLING CAPACITIES# CONTINUED

EVAPORATOR AIR		CONDENSER ENTERING AIR TEMPERATURES °F (°C)																	
CFM	EWB °F (°C)	75 (23.9)			85 (29.4)			95 (35)			105 (40.6)			115 (46.1)			125 (51.7)		
		Capacity MBtuh	Sens†	Total System KW**	Capacity MBtuh	Sens†	Total System KW**	Capacity MBtuh	Sens†	Total System KW**	Capacity MBtuh	Sens†	Total System KW**	Capacity MBtuh	Sens†	Total System KW**	Capacity MBtuh	Sens†	Total System KW**
N4H436 Outdoor Section With FEM4X36**BL Indoor Section																			
	72 (22.2)	39.42	20.36	2.23	37.61	19.67	2.50	35.70	18.96	2.79	33.63	18.20	3.10	31.37	17.37	3.46	28.97	16.51	3.85
	67 (19.4)	35.87	25.19	2.24	34.23	24.50	2.50	32.48	23.78	2.78	30.59	23.01	3.09	28.52	22.17	3.44	26.33	21.29	3.84
1050	63 (17.2)††	33.28	24.23	2.25	31.76	23.54	2.50	30.14	22.82	2.77	28.38	22.05	3.08	26.45	21.21	3.43	24.41	20.32	3.84
	62 (16.7)	32.68	29.85	2.25	31.22	29.12	2.50	29.67	28.32	2.77	27.40	27.40	3.08	26.31	26.31	3.43	24.65	24.65	3.84
	57 (13.9)	31.63	31.63	2.26	30.46	30.46	2.50	29.20	27.82	2.77	28.03	27.82	3.08	26.28	26.28	3.43	24.62	24.62	3.84
	72 (22.2)	40.13	21.34	2.27	38.25	20.63	2.54	36.25	19.90	2.83	34.10	19.12	3.14	31.76	18.28	3.50	29.28	17.40	3.90
	67 (19.4)	36.53	26.77	2.28	34.82	26.07	2.54	33.00	25.34	2.82	31.03	24.54	3.13	28.88	23.67	3.49	26.62	22.75	3.89
1200	63 (17.2)††	33.92	25.70	2.29	32.33	25.00	2.54	30.31	24.26	2.82	28.81	23.47	3.13	26.81	22.59	3.48	24.71	21.66	3.88
	62 (16.7)	33.39	31.85	2.29	31.89	31.02	2.54	30.31	30.31	2.82	28.80	28.80	3.12	27.16	27.16	3.48	25.40	25.40	3.88
	57 (13.9)	32.83	32.83	2.29	31.58	31.58	2.54	30.24	30.24	2.82	28.77	28.77	3.12	27.13	27.13	3.48	25.37	25.37	3.88
	72 (22.2)	40.68	22.25	2.31	38.72	21.53	2.58	36.66	20.80	2.82	34.45	20.01	3.19	32.03	19.15	3.54	29.50	18.26	3.94
1350	67 (19.4)	37.04	28.29	2.32	35.25	27.57	2.58	33.37	26.81	2.86	31.35	25.98	3.17	29.14	25.07	3.53	26.85	24.10	3.93
	63 (17.2)††	34.40	27.11	2.33	32.75	26.38	2.58	31.00	25.62	2.86	29.12	24.79	3.17	27.07	23.87	3.52	24.93	22.89	3.92
	62 (16.7)	33.95	33.95	2.33	32.55	32.55	2.58	31.13	31.13	2.86	29.57	29.57	3.17	27.85	27.85	3.52	26.00	26.00	3.93
	57 (13.9)	33.84	33.84	2.33	32.51	32.51	2.58	31.10	31.10	2.86	29.54	29.54	3.17	27.82	27.82	3.52	25.98	25.98	3.93

EVAPORATOR AIR		CONDENSER ENTERING AIR TEMPERATURES °F (°C)																	
CFM	EWB °F (°C)	75 (23.9)			85 (29.4)			95 (35)			105 (40.6)			115 (46.1)			125 (51.7)		
		Capacity MBtuh	Sens†	Total System KW**	Capacity MBtuh	Sens†	Total System KW**	Capacity MBtuh	Sens†	Total System KW**	Capacity MBtuh	Sens†	Total System KW**	Capacity MBtuh	Sens†	Total System KW**	Capacity MBtuh	Sens†	Total System KW**
N4H442 Outdoor Section With FEM4X42**BL Indoor Section																			
	72 (22.2)	48.18	24.31	2.78	46.14	23.54	3.12	43.91	22.72	3.47	41.39	21.79	3.89	38.48	20.75	4.38	35.14	19.57	4.98
	67 (19.4)	43.90	29.85	2.81	42.03	29.07	3.13	40.00	28.24	3.48	37.70	27.31	3.88	35.04	26.26	4.38	31.98	25.05	5.00
1225	63 (17.2)††	40.78	28.76	2.83	39.02	27.98	3.14	37.15	27.15	3.48	35.01	26.22	3.88	32.54	25.16	4.38	29.68	23.95	5.01
	62 (16.7)	40.02	35.22	2.83	38.32	34.41	3.14	36.51	33.54	3.48	34.48	32.52	3.88	32.15	32.15	4.38	29.82	29.82	5.01
	57 (13.9)	38.47	38.47	2.84	37.12	37.12	3.14	35.68	35.68	3.48	34.03	34.03	3.88	32.08	32.08	4.38	29.78	29.78	5.01
	72 (22.2)	49.11	25.48	2.81	46.98	24.70	3.15	44.64	23.85	3.51	42.03	22.91	3.92	39.00	21.85	4.41	35.57	20.66	5.02
1400	67 (19.4)	44.77	31.73	2.84	42.82	30.94	3.17	40.70	30.10	3.51	38.30	29.14	3.92	35.55	28.06	4.42	32.39	26.81	5.03
	63 (17.2)††	41.63	30.52	2.86	39.80	29.72	3.17	37.83	28.87	3.52	35.61	27.92	3.92	33.04	26.83	4.42	30.10	25.58	5.04
	62 (16.7)	40.95	37.70	2.86	39.20	35.82	3.18	37.36	35.82	3.52	35.36	35.36	3.92	33.27	33.27	4.42	30.82	30.82	5.04
	57 (13.9)	40.07	40.07	2.87	38.63	38.63	3.18	37.09	37.09	3.52	35.31	35.31	3.92	33.23	33.23	4.42	30.78	30.78	5.04
	72 (22.2)	49.81	26.57	2.84	47.60	25.78	3.18	45.20	24.93	3.54	42.49	23.97	3.96	39.38	22.90	4.44	35.86	21.70	5.05
1575	67 (19.4)	45.44	33.53	2.87	43.31	31.85	3.20	41.22	30.88	3.55	38.75	30.88	3.96	35.92	29.75	4.45	32.71	28.46	5.06
	63 (17.2)††	42.28	32.19	2.89	40.38	31.38	3.21	38.36	30.51	3.55	36.06	29.53	3.96	33.43	28.40	4.45	30.42	27.09	5.08
	62 (16.7)	41.76	39.89	2.89	39.97	39.97	3.21	38.30	38.30	3.55	36.41	36.41	3.96	34.21	34.21	4.45	31.64	31.64	5.07
	57 (13.9)	41.40	41.40	2.90	39.89	39.89	3.21	38.25	38.25	3.55	36.36	36.36	3.96	34.17	34.17	4.45	31.60	31.60	5.07

EVAPORATOR AIR		CONDENSER ENTERING AIR TEMPERATURES °F (°C)																	
CFM	EWB °F (°C)	75 (23.9)			85 (29.4)			95 (35)			105 (40.6)			115 (46.1)			125 (51.7)		
		Capacity MBtuh	Sens†	Total System KW**	Capacity MBtuh	Sens†	Total System KW**	Capacity MBtuh	Sens†	Total System KW**	Capacity MBtuh	Sens†	Total System KW**	Capacity MBtuh	Sens†	Total System KW**	Capacity MBtuh	Sens†	Total System KW**
N4H448 Outdoor Section With FEM4X48**BL Indoor Section																			
	72 (22.2)	55.75	28.05	3.23	53.27	27.12	3.59	50.55	26.11	3.96	47.46	24.99	4.37	44.01	23.75	4.83	40.13	22.38	5.35
	67 (19.4)	50.68	34.45	3.22	48.45	33.53	3.57	46.00	32.52	3.93	43.23	31.42	4.34	40.10	30.17	4.80	36.59	28.79	5.33
1400	63 (17.2)††	46.99	33.15	3.22	44.92	32.23	3.55	42.67	30.14	3.91	40.12	30.14	4.31	37.25	28.91	4.78	34.00	27.52	5.32
	62 (16.7)	46.10	40.65	3.21	44.11	39.69	3.55	41.94	38.63	3.91	39.54	37.40	4.31	36.87	36.87	4.77	34.21	34.21	5.32
	57 (13.9)	44.33	44.33	3.21	42.76	42.76	3.54	41.05	41.05	3.90	39.07	39.07	4.30	36.80	36.80	4.77	34.17	34.17	5.32
	72 (22.2)	56.80	29.37	3.28	54.22	28.42	3.62	51.35	27.39	4.01	48.15	26.25	4.42	44.55	24.98	4.88	40.56	23.60	5.40
1600	67 (19.4)	51.68	36.59	3.28	49.35	35.66	3.62	46.77	34.62	3.99	43.87	33.48	4.39	40.64	32.20	4.85	37.01	30.76	5.38
	63 (17.2)††	47.95	35.15	3.27	45.79	34.21	3.61	43.42	33.18	3.96	40.77	32.06	4.37	37.78	30.79	4.83	34.43	29.35	5.37
	62 (16.7)	47.16	43.44	3.27	45.10	42.39	3.60	42.90	41.17	3.96	40.54	40.54	4.37	38.10	38.10	4.83	35.30	35.30	5.38
	57 (13.9)	46.14	46.14	3.26	44.46	44.46	3.60	42.61	42.61	3.96	40.49	40.49	4.37	38.06	38.06	4.83	35.26	35.26	5.37
	72 (22.2)	57.65	30.65	3.33	54.96	29.68	3.69	52.00	28.64	4.06	48.67	27.48	4.47	44.97	26.19	4.93	40.86	24.79	5.45
1800	67 (19.4)	52.48	38.69	3.33	50.04	37.72	3.67	47.37	36.85	4.04	44.38	35.48	4.45	41.04	34.15	4.91	37.34	32.64	5.44
	63 (17.2)††	48.72	37.10	3.32	46.72	35.07	3.66	44.02	35.07	4.02	41.28	33.91	4.42	38.20	32.58	4.88	34.78	31.07	5.42
	62 (16.7)	48.09	45.92	3.32	45.99	45.99	3.66	43.96	43.96	4.02	41.71	41.71	4.43	39.13	39.13	4.89	36.17	36.17	5.43
	57 (13.9)	47.65	47.65	3.32	45.88	45.88	3.66	43.91	43.91	4.02	41.66	41.66	4.43	39.09	39.09	4.89	36.13	36.13	5.43

See notes on page 5

DETAILED COOLING CAPACITIES# CONTINUED

EVAPORATOR AIR		CONDENSER ENTERING AIR TEMPERATURES °F (°C)																	
		75 (23.9)			85 (29.4)			95 (35)			105 (40.6)			115 (46.1)			125 (51.7)		
		CFM	EWB °F (°C)	Capacity MBtuh		Total System KW**	Capacity MBtuh		Total System KW**	Capacity MBtuh		Total System KW**	Capacity MBtuh		Total System KW**	Capacity MBtuh		Total System KW**	
Total	Sens†			Total	Sens†		Total	Sens†		Total	Sens†		Total	Sens†					
N4H460 Outdoor Section With FXM4X60**AL Indoor Section																			
1750	72 (22.2)	64.47	36.36	3.53	61.69	35.21	3.88	58.75	34.01	4.30	55.61	32.74	4.78	52.18	31.36	5.34	48.43	29.90	5.99
	67 (19.4)	58.76	44.97	3.50	56.25	43.82	3.86	53.58	42.62	4.27	50.71	41.34	4.76	47.58	39.96	5.32	44.10	38.44	5.96
	63 (17.2)††	54.60	43.31	3.48	52.27	42.16	3.84	49.79	40.96	4.25	47.13	39.68	4.74	44.21	38.28	5.29	40.98	36.76	5.94
	62 (16.7)	53.59	53.34	3.48	51.34	52.14	3.84	48.98	50.87	4.25	46.43	49.42	4.73	43.81	43.81	5.29	41.19	41.19	5.94
	57 (13.9)	51.87	51.87	3.47	50.08	50.08	3.83	48.17	48.17	4.25	46.08	46.08	4.73	43.74	43.74	5.29	41.14	41.14	5.94
2000	72 (22.2)	65.61	38.13	3.59	62.71	36.95	3.95	59.66	35.74	4.37	56.39	34.44	4.85	52.83	33.04	5.41	48.97	31.55	6.06
	67 (19.4)	59.86	47.88	3.57	57.21	46.69	3.92	54.43	45.47	4.34	51.45	44.16	4.82	48.19	42.72	5.38	44.64	41.17	6.03
	63 (17.2)††	55.66	46.01	3.55	53.22	44.83	3.91	50.84	43.61	4.32	47.87	42.29	4.80	44.85	40.86	5.36	41.52	39.29	6.01
	62 (16.7)	54.79	57.14	3.55	52.47	55.78	3.90	50.08	50.08	4.32	47.80	47.80	4.80	45.32	45.32	5.36	42.54	42.54	6.02
	57 (13.9)	53.97	53.97	3.54	52.05	52.05	3.90	49.99	49.99	4.32	47.74	47.74	4.80	45.26	45.26	5.36	42.49	42.49	6.02
2250	72 (22.2)	66.47	39.80	3.66	63.48	38.61	4.02	60.32	37.37	4.43	56.96	36.06	4.91	53.30	34.64	5.47	49.33	33.13	6.12
	67 (19.4)	60.67	50.65	3.63	57.94	49.44	3.99	55.07	48.18	4.40	51.99	46.83	4.89	48.67	45.37	5.45	45.03	43.74	6.09
	63 (17.2)††	56.46	48.58	3.61	53.93	47.38	3.97	51.26	46.11	4.38	48.41	44.76	4.87	45.32	43.28	5.43	41.91	41.63	6.07
	62 (16.7)	55.83	55.83	3.61	53.75	53.75	3.97	51.56	51.56	4.39	48.17	48.17	4.87	46.57	46.57	5.44	43.63	43.63	6.09
	57 (13.9)	55.71	55.71	3.61	53.68	53.68	3.97	51.49	51.49	4.39	49.12	49.12	4.87	46.49	46.49	5.43	43.58	43.58	6.09

† Total and sensible capacities are net capacities. Blower motor heat has been subtracted.

‡ Sensible capacities shown are based on 80° F (27° C) entering air at the indoor coil. For sensible capacities at other than 80° F (27° C), deduct 835 Btuh (245 kW) per 1000 CFM (480 L/S) of indoor coil air for each degree below 80° F (27° C), or add 835 Btuh (245 kW) per 1000 CFM (480 L/S) of indoor coil air per degree above 80° F (27° C).

Detailed cooling capacities are based on indoor and outdoor unit at the same elevation per AHRI standard 210/240-2008. If additional tubing length and/or indoor unit is located above outdoor unit, a slight variation in capacity may occur.

** Sys. kw is total of indoor and outdoor unit kilowatts.

†† At TVA rating indoor condition (75° F edb/63° F ewb). All other indoor air temperatures are at 80° F edb.

NOTE: When the required data falls between the published data, interpolation may be performed. Extrapolation is not an acceptable practice.

EWB — Entering Wet Bulb

HEAT PUMP HEATING PERFORMANCE

INDOOR AIR		OUTDOOR COIL ENTERING AIR TEMPERATURES °F (°C)																							
EDB °F (°C)	CFM	-3 (19.4)			7 (-13.9)			17 (-8.3)			27 (-2.8)			37 (2.8)			47 (8.3)			57 (13.9)			67 (19.4)		
		Capacity MBtuh	Total Sys-tem KW	Integ	Capacity MBtuh	Total Sys-tem KW	Integ	Capacity MBtuh	Total Sys-tem KW	Integ	Capacity MBtuh	Total Sys-tem KW	Integ	Capacity MBtuh	Total Sys-tem KW	Integ	Capacity MBtuh	Total Sys-tem KW	Integ	Capacity MBtuh	Total Sys-tem KW	Integ	Capacity MBtuh	Total Sys-tem KW	Integ
N4H418 Outdoor Section With FEM4X18**BL Indoor Section																									
65	525	5.26	4.84	1.03	7.45	6.84	1.09	9.80	8.94	1.14	12.54	11.14	1.21	15.07	13.71	1.27	17.87	17.87	1.35	21.00	21.00	1.40	24.19	24.19	1.53
	600	5.36	4.93	1.04	7.57	6.95	1.09	9.96	9.08	1.13	12.70	11.28	1.19	15.26	13.89	1.24	18.13	18.13	1.31	21.35	21.35	1.40	24.32	24.32	1.47
	675	5.44	5.01	1.04	7.66	7.04	1.09	10.09	9.20	1.13	12.83	11.40	1.18	15.43	14.04	1.23	18.33	18.33	1.29	21.54	21.54	1.37	24.32	24.32	1.43
70	525	4.98	4.58	1.08	7.15	6.57	1.14	9.49	8.65	1.20	12.28	10.90	1.27	14.78	13.45	1.33	17.54	17.54	1.41	20.61	20.61	1.51	23.84	23.84	1.61
	600	5.08	4.67	1.08	7.27	6.68	1.14	9.64	8.79	1.19	12.45	11.05	1.25	14.98	13.63	1.31	17.80	17.80	1.38	20.95	20.95	1.47	24.01	24.01	1.55
	675	5.16	4.75	1.09	7.38	6.78	1.14	9.77	8.91	1.18	12.58	11.17	1.24	15.14	13.78	1.29	18.01	18.01	1.36	21.21	21.21	1.44	24.05	24.05	1.50
75	525	4.65	4.28	1.13	6.83	6.27	1.19	9.15	8.35	1.25	11.98	10.64	1.33	14.49	13.19	1.40	17.21	17.21	1.48	20.22	20.22	1.58	23.47	23.47	1.69
	600	4.74	4.36	1.13	6.95	6.39	1.19	9.31	8.49	1.24	12.16	10.80	1.31	14.69	13.37	1.37	17.46	17.46	1.45	20.55	20.55	1.54	23.68	23.68	1.62
	675	4.84	4.45	1.14	7.05	6.48	1.19	9.44	8.61	1.24	12.30	10.93	1.30	14.86	13.52	1.36	17.67	17.67	1.42	20.82	20.82	1.51	23.75	23.75	1.58
N4H424 Outdoor Section With FEM4X24**CL Indoor Section																									
65	700	8.09	7.45	1.53	10.51	9.65	1.59	13.25	12.08	1.65	16.10	14.30	1.71	18.99	17.28	1.79	22.27	22.27	1.88	26.02	26.02	1.98	29.55	29.55	2.06
	800	8.23	7.57	1.54	10.66	9.80	1.58	13.63	12.43	1.64	16.28	14.46	1.70	19.22	17.49	1.76	22.55	22.55	1.84	26.19	26.19	1.92	29.49	29.49	2.00
	900	8.35	7.69	1.54	10.81	9.93	1.59	13.78	12.56	1.64	16.44	14.60	1.69	19.41	17.67	1.74	22.78	22.78	1.82	26.20	26.20	1.89	29.26	29.26	1.95
70	700	7.69	7.08	1.60	10.12	9.30	1.66	12.77	11.64	1.72	15.81	14.04	1.80	18.67	16.99	1.87	21.95	21.95	1.96	25.62	25.62	2.08	29.23	29.23	2.16
	800	7.84	7.21	1.60	10.29	9.45	1.65	12.99	11.84	1.71	15.99	14.20	1.78	18.89	17.19	1.84	22.20	22.20	1.93	25.88	25.88	2.02	29.23	29.23	2.10
	900	7.96	7.32	1.61	10.43	9.59	1.66	13.21	12.05	1.71	16.16	14.35	1.77	19.08	17.37	1.83	22.42	22.42	1.91	25.96	25.96	1.98	29.10	29.10	2.05
75	700	7.30	6.71	1.67	9.74	8.95	1.73	12.37	11.28	1.80	15.54	13.80	1.88	18.37	16.72	1.96	21.60	21.60	2.06	25.21	25.21	2.18	28.90	28.90	2.26
	800	7.44	6.84	1.67	9.90	9.10	1.73	12.57	11.46	1.79	15.73	13.97	1.86	18.58	16.91	1.93	21.86	21.86	2.02	25.53	25.53	2.12	28.93	28.93	2.20
	900	7.55	6.95	1.68	10.03	9.22	1.73	12.73	11.61	1.79	15.88	14.10	1.85	18.76	17.07	1.92	22.08	22.08	2.00	25.68	25.68	2.08	28.88	28.88	2.15
N4H430 Outdoor Section With FEM4X30**BL Indoor Section																									
65	875	10.54	9.70	1.80	13.55	12.45	1.87	17.16	15.64	1.95	20.49	18.19	2.04	24.30	22.12	2.14	28.57	28.57	2.26	33.42	33.42	2.40	37.91	37.91	2.51
	1050	10.81	9.95	1.81	13.87	12.75	1.88	17.44	15.90	1.95	20.83	18.50	2.02	24.73	22.50	2.11	29.10	29.10	2.22	33.84	33.84	2.34	37.90	37.90	2.43
	1125	10.91	10.04	1.82	13.99	12.85	1.88	17.54	15.99	1.95	20.96	18.61	2.02	24.88	22.64	2.11	29.28	29.28	2.22	33.88	33.88	2.32	37.80	37.80	2.41
70	875	10.08	9.27	1.87	13.10	12.04	1.95	16.82	15.34	2.04	20.13	17.88	2.13	23.89	21.74	2.23	28.09	28.09	2.35	32.88	32.88	2.50	37.48	37.48	2.62
	1050	10.34	9.51	1.89	13.40	12.31	1.95	17.12	15.61	2.03	20.47	18.18	2.11	24.31	22.12	2.20	28.60	28.60	2.31	33.42	33.42	2.44	37.51	37.51	2.53
	1125	10.44	9.60	1.90	13.51	12.42	1.96	17.23	15.71	2.04	20.59	18.29	2.11	24.46	22.26	2.20	28.79	28.79	2.31	33.53	33.53	2.42	37.51	37.51	2.53
75	875	9.61	8.84	1.95	12.64	11.62	2.02	16.08	14.66	2.11	19.78	17.57	2.22	23.48	21.37	2.32	27.62	27.62	2.45	32.34	32.34	2.60	37.01	37.01	2.73
	1050	9.86	9.07	1.96	12.94	11.89	2.03	16.76	15.28	2.12	20.11	17.86	2.20	23.89	21.74	2.30	28.11	28.11	2.41	32.93	32.93	2.54	37.11	37.11	2.64
	1125	9.95	9.16	1.97	13.05	11.99	2.04	16.87	15.39	2.12	20.23	17.97	2.20	24.04	21.88	2.29	28.30	28.30	2.40	33.08	33.08	2.52	37.07	37.07	2.62
N4H436 Outdoor Section With FEM4X36**BL Indoor Section																									
65	1050	12.92	11.89	2.18	16.50	15.16	2.26	20.40	18.60	2.34	24.90	22.12	2.45	29.12	26.50	2.55	33.86	33.86	2.66	39.25	39.25	2.81	45.49	45.49	3.02
	1200	13.19	12.13	2.20	16.81	15.44	2.27	20.77	18.94	2.35	25.23	22.40	2.44	29.49	26.84	2.53	34.32	34.32	2.63	39.87	39.87	2.76	46.23	46.23	2.94
	1350	13.43	12.35	2.23	17.08	15.69	2.29	21.13	19.27	2.36	25.51	22.66	2.44	29.82	27.14	2.52	34.70	34.70	2.61	40.38	40.38	2.74	46.70	46.70	2.88
70	1050	12.30	11.32	2.26	15.91	14.62	2.34	19.81	18.06	2.43	24.51	21.77	2.55	28.67	26.09	2.65	33.35	33.35	2.77	38.60	38.60	2.93	44.71	44.71	3.15
	1200	12.56	11.56	2.28	16.22	14.90	2.36	20.15	18.38	2.44	24.82	22.05	2.54	29.04	26.43	2.63	33.80	33.80	2.74	39.20	39.20	2.88	45.47	45.47	3.07
	1350	12.80	11.77	2.31	16.48	15.15	2.38	20.47	18.66	2.45	25.10	22.29	2.53	29.36	26.72	2.63	34.19	34.19	2.72	39.70	39.70	2.85	46.01	46.01	3.02
75	1050	11.66	10.73	2.35	15.30	14.06	2.43	19.20	17.50	2.53	24.07	21.37	2.66	28.23	25.69	2.77	32.83	32.83	2.89	37.95	37.95	3.06	43.92	43.92	3.29
	1200	11.92	10.97	2.37	15.60	14.34	2.45	19.54	17.82	2.53	24.41	21.68	2.65	28.60	26.02	2.75	33.28	33.28	2.85	38.54	38.54	3.00	44.68	44.68	3.22
	1350	12.15	11.18	2.40	15.87	14.58	2.47	19.85	18.10	2.55	24.69	21.93	2.65	28.91	26.31	2.74	33.66	33.66	2.84	39.03	39.03	2.98	45.28	45.28	3.16

See notes on page 7

HEAT PUMP HEATING PERFORMANCE CONTINUED

INDOOR AIR		OUTDOOR COIL ENTERING AIR TEMPERATURES °F (°C)																							
EDB °F (°C)	CFM	-3 (19.4)			7 (-13.9)			17 (-8.3)			27 (-2.8)			37 (2.8)			47 (8.3)			57 (13.9)			67 (19.4)		
		Capacity MBtuh	Total Sys-tem kW	Integ	Capacity MBtuh	Total Sys-tem kW	Integ	Capacity MBtuh	Total Sys-tem kW	Integ	Capacity MBtuh	Total Sys-tem kW	Integ	Capacity MBtuh	Total Sys-tem kW	Integ	Capacity MBtuh	Total Sys-tem kW	Integ	Capacity MBtuh	Total Sys-tem kW	Integ	Capacity MBtuh	Total Sys-tem kW	Integ
65	1225	15.59	14.35	2.48	19.93	18.31	22.84	24.83	22.84	2.71	30.26	26.88	2.87	35.66	32.45	3.01	41.58	41.58	3.18	48.02	48.02	3.34	53.69	53.69	3.47
	1400	15.91	14.64	2.50	20.28	18.64	23.48	25.75	23.48	2.72	30.80	27.17	2.84	36.05	32.81	2.98	42.10	42.10	3.14	48.21	48.21	3.26	53.51	53.51	3.37
	1575	16.19	14.89	2.51	20.58	18.91	23.75	26.05	23.75	2.72	30.91	27.46	2.84	36.39	33.12	2.96	42.45	42.45	3.10	48.18	48.18	3.20	53.24	53.24	3.31
	1225	14.78	13.60	2.58	19.20	17.64	21.93	24.06	21.93	2.82	29.80	26.47	2.98	35.19	32.05	3.10	41.00	41.00	3.32	47.42	47.42	3.48	53.09	53.09	3.52
	1400	15.07	13.87	2.59	19.52	17.94	22.28	24.44	22.28	2.81	30.13	26.76	2.96	35.55	32.35	3.14	41.49	41.49	3.27	47.70	47.70	3.40	52.99	52.99	3.62
70	1575	15.33	14.10	2.61	19.82	18.21	22.70	24.79	22.70	2.82	30.42	27.02	2.95	35.89	32.66	3.09	41.91	41.91	3.24	47.75	47.75	3.35	52.74	52.74	3.45
	1225	14.00	12.88	2.68	18.50	17.00	21.32	23.38	21.32	2.93	29.35	26.07	3.11	34.70	31.57	3.28	40.41	40.41	3.47	46.83	46.83	3.64	52.47	52.47	3.79
	1400	14.27	13.13	2.69	18.80	17.28	21.65	23.74	21.65	2.92	29.68	26.36	3.07	35.07	31.92	3.24	40.89	40.89	3.41	47.13	47.13	3.55	52.43	52.43	3.68
	1575	14.51	13.34	2.71	19.07	17.53	21.93	24.05	21.93	2.93	29.95	26.60	3.07	35.39	32.20	3.21	41.30	41.30	3.38	47.26	47.26	3.50	52.43	52.43	3.60
	1400	16.35	15.04	2.75	21.40	19.66	24.46	26.82	24.46	3.00	33.50	29.76	3.17	39.20	35.67	3.31	45.68	45.68	3.48	53.36	53.36	3.67	61.87	61.87	3.84
65	1600	16.69	15.36	2.78	21.78	20.01	24.85	27.25	24.85	3.00	33.88	30.09	3.16	39.67	36.10	3.29	46.26	46.26	3.44	54.19	54.19	3.61	62.42	62.42	3.76
	1800	17.00	15.64	2.81	22.12	20.33	25.20	27.64	25.20	3.02	34.22	30.40	3.17	40.06	36.45	3.28	46.75	46.75	3.42	54.77	54.77	3.57	62.78	62.78	3.72
	1400	15.48	14.25	2.85	20.60	18.93	22.97	26.05	23.75	3.11	32.86	29.19	3.29	38.68	35.20	3.45	45.00	45.00	3.62	52.51	52.51	3.82	61.02	61.02	4.00
	1600	15.80	14.54	2.87	20.97	19.27	23.29	26.47	24.14	3.12	33.35	29.62	3.28	39.10	35.58	3.42	45.56	45.56	3.58	53.28	53.28	3.75	61.59	61.59	3.92
	1800	16.05	14.76	2.91	21.28	19.55	23.62	26.84	24.47	3.13	33.71	29.94	3.29	39.47	35.92	3.42	46.04	46.04	3.56	53.98	53.98	3.72	61.98	61.98	3.87
85	1400	13.11	12.07	3.19	18.31	16.83	21.72	23.83	21.72	3.50	29.75	26.42	3.67	37.16	33.82	3.93	43.00	43.00	4.12	49.89	49.89	4.32	58.18	58.18	4.52
	1600	13.37	12.30	3.22	18.63	17.12	22.07	24.21	22.07	3.50	30.22	26.84	3.66	37.55	34.17	3.89	43.52	43.52	4.07	50.66	50.66	4.25	58.86	58.86	4.43
	1800	13.58	12.49	3.25	18.88	17.35	22.34	24.50	22.34	3.51	30.57	27.15	3.66	37.88	34.48	3.87	43.96	43.96	4.04	51.35	51.35	4.20	59.33	59.33	4.37
	1750	21.14	19.45	3.33	26.85	24.67	30.23	33.16	30.23	3.60	40.66	36.11	3.79	47.51	43.23	3.95	55.22	55.22	4.13	64.29	64.29	4.32	73.31	73.31	4.50
	2000	21.51	19.79	3.36	27.26	25.05	30.68	33.65	30.68	3.61	41.05	36.45	3.77	48.03	43.70	3.92	55.88	55.88	4.08	64.95	64.95	4.23	73.54	73.54	4.40
65	2250	21.84	20.10	3.40	27.62	25.39	31.11	34.07	31.07	3.63	41.40	36.77	3.78	48.48	44.12	3.91	56.46	56.46	4.07	65.31	65.31	4.19	73.39	73.39	4.34
	1750	20.38	18.75	3.48	26.13	24.01	29.54	32.40	29.54	3.76	40.19	35.69	3.97	46.94	42.71	4.14	54.50	54.50	4.32	63.44	63.44	4.51	72.41	72.41	4.70
	2000	20.74	19.08	3.51	26.54	24.39	30.00	32.87	29.97	3.77	40.59	36.05	3.96	47.44	43.17	4.11	55.15	55.15	4.27	64.14	64.14	4.42	72.69	72.69	4.60
	2250	21.08	19.40	3.55	26.91	24.73	30.36	33.30	30.36	3.79	40.95	36.37	3.96	47.88	43.57	4.09	55.71	55.71	4.25	64.55	64.55	4.38	72.63	72.63	4.53
	1750	19.58	18.01	3.63	25.36	23.30	28.83	31.62	28.83	3.94	39.67	35.23	4.16	46.37	42.20	4.33	53.80	53.80	4.52	62.59	62.59	4.72	71.50	71.50	4.92
75	2000	19.94	18.35	3.67	25.78	23.69	29.27	32.10	29.27	3.94	40.12	35.64	4.14	46.85	42.63	4.29	54.42	54.42	4.46	63.33	63.33	4.63	71.81	71.81	4.80
	2250	20.28	18.65	3.71	26.15	24.03	29.65	32.52	29.65	3.96	40.49	35.96	4.14	47.28	43.02	4.28	54.97	54.97	4.43	63.78	63.78	4.57	71.82	71.82	4.73
	1400	16.35	15.04	2.75	21.40	19.66	24.46	26.82	24.46	3.00	33.50	29.76	3.17	39.20	35.67	3.31	45.68	45.68	3.48	53.36	53.36	3.67	61.87	61.87	3.84
	1600	16.69	15.36	2.78	21.78	20.01	24.85	27.25	24.85	3.00	33.88	30.09	3.16	39.67	36.10	3.29	46.26	46.26	3.44	54.19	54.19	3.61	62.42	62.42	3.76
	1800	17.00	15.64	2.81	22.12	20.33	25.20	27.64	25.20	3.02	34.22	30.40	3.17	40.06	36.45	3.28	46.75	46.75	3.42	54.77	54.77	3.57	62.78	62.78	3.72

NOTE: When the required data falls between the published data, interpolation may be performed. Extrapolation is not an acceptable practice.

* The Btuh heating capacity values shown are net integrated values from which the defrost effect has been subtracted. The Btuh heating from supplement heaters should be added to those values to obtain total Sys. capacity.

† The kW values include the compressor, outdoor fan motor, and indoor blower motor. The kW from supplement heaters should be added to these values to obtain total Sys. kilowatts.

EDB — Entering Dry Bulb

Accessory Description and Usage (Listed Alphabetically)

1. Ball-Bearing Fan Motor

A fan motor with ball bearings which permits speed reduction while maintaining bearing lubrication.

2. Compressor Start Assist – Capacitor and Relay

Start capacitor and relay gives a hard boost to compressor motor at each start up.

Usage Guideline:

Required for reciprocating compressors in the following applications:

- Long line
- Low ambient cooling
- Hard shut off expansion valve on indoor coil
- Liquid line solenoid on indoor coil

Required for single-phase scroll compressors in the following applications:

- Long line
- Low ambient cooling

Suggested for all compressors in areas with a history of low voltage problems.

3. Compressor Start Assist — PTC Type

Solid state electrical device which gives a soft boost to the compressor at each start-up.

Usage Guideline:

Suggested in installations with marginal power supply.

4. Crankcase Heater

An electric resistance heater which mounts to the base of the compressor to keep the lubricant warm during off cycles. Improves compressor lubrication on restart and minimizes the chance of liquid slugging.

Usage Guideline:

- Required in low ambient cooling applications.
- Required in long line applications.
- Suggested in all commercial applications.

5. Evaporator Freeze Thermostat

An SPST temperature-actuated switch that stops unit operation when evaporator reaches freeze-up conditions.

Usage Guideline:

Required when low ambient kit has been added.

6. Isolation Relay

An SPDT relay which switches the low-ambient controller out of the outdoor fan motor circuit when the heat pump switches to heating mode.

Usage Guideline:

Required in all heat pumps where low ambient kit has been added.

7. Liquid-Line Solenoid Valve (LLS)

An electrically operated shutoff valve which stops and starts refrigerant liquid flow in response to compressor operation. It is to be installed at the outdoor unit to control refrigerant off cycle migration in the heating mode.

Usage Guideline:

An LLS is required in all long line heat pump applications to control refrigerant off cycle migration in the heating mode. See Long Line Guideline.

8. Low-Ambient Pressure Switch Kit

A long life pressure switch which is mounted to outdoor unit service valve. It is designed to cycle the outdoor fan motor in order to maintain head pressure within normal operating limits. The control will maintain working head pressure at low-ambient temperatures down to 0°F (-17.8°C) when properly installed.

Usage Guideline:

A Low-Ambient Pressure Switch Low-Ambient Controller must be used when cooling operation is used at outdoor temperatures below 55°F (12.8°C).

9. Sound Jacket

Wraparound sound reducing cover for the compressor. Reduces the sound level by about 2 dBA.

Usage Guideline:

Suggested when unit is installed closer than 15 ft. (4.577 m) to quiet areas, bedrooms, etc.

Suggested when unit is installed between two houses less than 10 ft. (3.05 m) apart.

10. Thermostatic Expansion Valve (TXV) Bi-Flow

A modulating flow-control valve which meters refrigerant liquid flow rate into the evaporator in response to the superheat of the refrigerant gas leaving the evaporator.

Usage Guideline:

Accessory required to meet AHRI rating and system reliability, where indoor not equipped. Required in all heat pump applications designed with R-410A refrigerant.

11. Time-Delay Relay

An SPST delay relay which briefly continues operation of indoor blower motor to provide additional cooling after the compressor cycles off.

Note: Most indoor unit controls include this feature. For those that do not, use the guideline below.

Usage Guideline:

Accessory required to meet AHRI rating, where indoor not equipped.

ACCESSORY USAGE GUIDELINE

ACCESSORY	REQUIRED FOR LOW-AMBIENT COOLING APPLICATIONS (Below 55°F / 12.8°C)	REQUIRED FOR LONG LINE APPLICATIONS*	REQUIRED FOR SEA COAST APPLICATIONS (Within 2 miles/3.22 km)
Accumulator	Standard	Standard	Standard
Compressor Start Assist Capacitor and Relay	Yes	Yes	No
Crankcase Heater	Yes	Yes	No
Evaporator Freeze Thermostat	Yes	No	No
Hard Shutoff TXV	Yes	Yes	No
Isolation Relay	Yes	No	No
Liquid Line Solenoid Valve	No	See Long-Line Application Guideline	No
Low Ambient Switch	Yes	No	No
Support Feet	Recommended	No	Recommended

* For tubing line sets between 80 and 200 ft. (24.38 and 60.96 m) and/or 20 ft. (6.09 m) vertical differential, refer to Residential Split-System Longline Application Guideline.

ACCESSORIES

Part Number	Description	Used On Model Size
NASA001SC	Start Component – PTC Device	ALL
NASA00201FS	Evaporator Freeze Thermostat	ALL
NASA001LS	Liquid Line Solenoid Valve	ALL
NASA001TD	Time Delay Relay, Indoor Blower	ALL
NASA001AC	Anti-Cycle Timer (5 minute delay)	ALL
NASA401LA	Low Ambient Kit (Pressure Switch)	ALL
NASA00101IK	Low Ambient Isolation Relay Kit	ALL
NASA001SF	Support Feet, 4" (102mm) tall	ALL
NASA003SC	Hard Start Kit (Capacitor & Relay)	ALL
NASA003CH	Crankcase Heater for Compressor	18, 24, 30, 36
NASA001CH	Crankcase Heater for Compressor	42, 48, 60
NASA002SJ	Sound Jacket, Compressor	18, 24, 30
NASA001SJ	Sound Jacket, Compressor	36, 42, 48
NASA003SJ	Sound Jacket, Compressor	60
EBAC05TXVX	TXV Kit, R-410A – 2005–2009 R-22 TXV Fancoils (air handlers)	18, 24, 30
EBAC06TXVX	TXV Kit, R-410A – 2005–2009 R-22 TXV Fancoils (air handlers)	36, 42
EBAC07TXVX	TXV Kit, R-410A – 2005–2009 R-22 TXV Fancoils (air handlers)	48, 60