



### FAN COILS

#### FXM4X

- 1½ thru 5 tons
- Available for Environmentally Sound R-410A systems
- TXV metering device factory installed
- High Efficiency, 3-speed, Genteq™ X-13 Motor (Brushless Permanent Magnet “BPM”, Electronically Commutated Motor “ECM”)
- Copper tube / aluminum fin coil
- Sweat connections
- Primary and secondary drain fittings with brass inserts
- 3 amp automotive type fuse in wire harness
- Multiple electrical entry locations
- Time delay relay (TDR) programmed in motor
- Field installed heater packages from 5 kW – 30 kW available separately
- HUD approved for manufactured housing
- 208/230-1-60 supply voltage
- Units tested and certified by manufacturer to achieve a 2% or less leakage rate at 1.0 inch water column
- 1 inch thick insulation with R value of 4.2
- Multiposition installation – upflow or horizontal left standard, horizontal right with minor modification (field convertible to downflow with available accessory kit)
- No Heat (Plug) Kit factory installed
- Filter factory supplied



Use of the AHRI Certified TM Mark indicates a manufacturer's participation in the program. For verification of certification for individual products, go to [www.ahridirectory.org](http://www.ahridirectory.org).



#### WARRANTY\*

- 5 year No Hassle replacement limited warranty
  - 5 year parts limited warranty
    - With timely registration, an additional 5 year parts limited warranty
- \* Applies to original purchaser/homeowner, some limitations may apply. See Warranty certificate for complete details.

Model Number	Tons	Nom. CFM (L/s)	Dimensions H x W x D in. (mm)	Filter Size in. (mm)	Ship Wt lbs. (kg)
FXM4X1800A	1½	600 (283)	49 <sup>5</sup> / <sub>8</sub> x 17 <sup>5</sup> / <sub>8</sub> x 22 <sup>1</sup> / <sub>16</sub> (1261 x 448 x 560)	16 <sup>3</sup> / <sub>8</sub> x 21 <sup>1</sup> / <sub>2</sub> (416 x 546)	122 (55)
FXM4X2400A	2	800 (378)	49 <sup>5</sup> / <sub>8</sub> x 17 <sup>5</sup> / <sub>8</sub> x 22 <sup>1</sup> / <sub>16</sub> (1261 x 448 x 560)	16 <sup>3</sup> / <sub>8</sub> x 21 <sup>1</sup> / <sub>2</sub> (416 x 546)	122 (55)
FXM4X3000A	2½	1000 (472)	53 <sup>7</sup> / <sub>16</sub> x 21 <sup>1</sup> / <sub>8</sub> x 22 <sup>1</sup> / <sub>16</sub> (1357 x 537 x 560)	19 <sup>7</sup> / <sub>8</sub> x 21 <sup>1</sup> / <sub>2</sub> (505 x 546)	146 (66)
FXM4X3600A	3	1200 (566)	49 <sup>5</sup> / <sub>8</sub> x 21 <sup>1</sup> / <sub>8</sub> x 22 <sup>1</sup> / <sub>16</sub> (1261 x 537 x 560)	19 <sup>7</sup> / <sub>8</sub> x 21 <sup>1</sup> / <sub>2</sub> (505 x 546)	157 (71)
FXM4X4200A	3½	1400 (661)	49 <sup>5</sup> / <sub>8</sub> x 21 <sup>1</sup> / <sub>8</sub> x 22 <sup>1</sup> / <sub>16</sub> (1261 x 537 x 560)	19 <sup>7</sup> / <sub>8</sub> x 21 <sup>1</sup> / <sub>2</sub> (505 x 546)	157 (71)
FXM4X4800A	4	1600 (755)	53 <sup>7</sup> / <sub>16</sub> x 24 <sup>1</sup> / <sub>16</sub> x 22 <sup>1</sup> / <sub>16</sub> (1357 x 627 x 560)	23 <sup>5</sup> / <sub>16</sub> x 21 <sup>1</sup> / <sub>2</sub> (592 x 546)	185 (84)
FXM4X6000A	5	2000 (944)	59 <sup>3</sup> / <sub>16</sub> x 24 <sup>1</sup> / <sub>16</sub> x 22 <sup>1</sup> / <sub>16</sub> (1503 x 627 x 560)	23 <sup>5</sup> / <sub>16</sub> x 21 <sup>1</sup> / <sub>2</sub> (592 x 546)	201 (91)

**CLEARANCES AND UNIT DIMENSIONS**

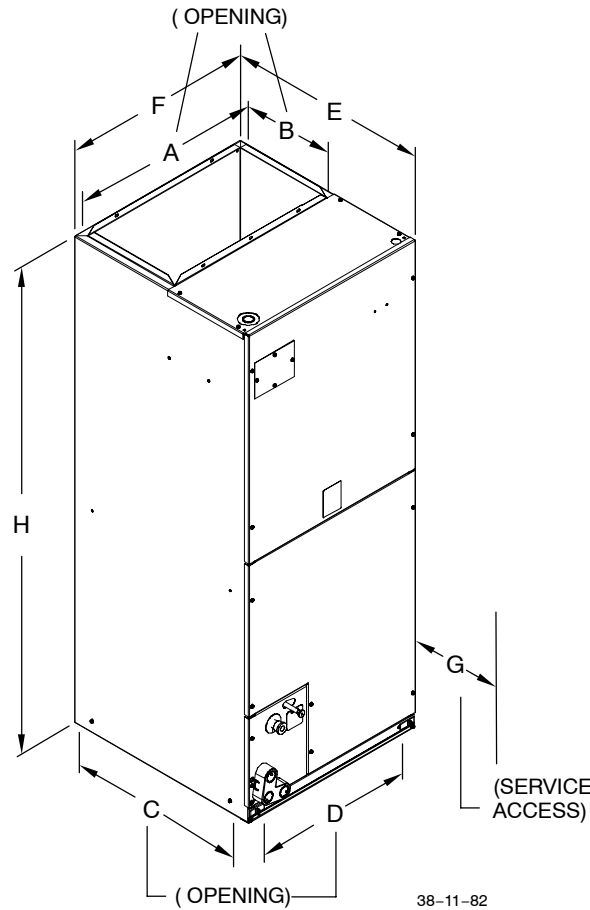

38-11-82

REQUIRED CLEARANCES - ALL MODELS inches (mm)								
No Heaters	All Sides	0						
	From Supply Duct	0						
With Heaters	All Sides	0						
	From First 3 feet of Supply Duct to Combustibles	1 (25)						
	From Supply Duct to Combustibles after 3 feet	0						
FXM (inches)								
Unit Size	A	B	C	D	E	F	G	H
1800	15 <sup>3</sup> / <sub>4</sub>	11	19 <sup>13</sup> / <sub>16</sub>	15 <sup>5</sup> / <sub>8</sub>	22 <sup>1</sup> / <sub>16</sub>	17 <sup>5</sup> / <sub>8</sub>	21	49 <sup>5</sup> / <sub>8</sub>
2400	15 <sup>3</sup> / <sub>4</sub>	11	19 <sup>13</sup> / <sub>16</sub>	15 <sup>5</sup> / <sub>8</sub>	22 <sup>1</sup> / <sub>16</sub>	17 <sup>5</sup> / <sub>8</sub>	21	49 <sup>5</sup> / <sub>8</sub>
3000	19 <sup>1</sup> / <sub>4</sub>	11	19 <sup>13</sup> / <sub>16</sub>	19 <sup>1</sup> / <sub>8</sub>	22 <sup>1</sup> / <sub>16</sub>	21 <sup>1</sup> / <sub>8</sub>	21	53 <sup>7</sup> / <sub>16</sub>
3600	19 <sup>1</sup> / <sub>4</sub>	11	19 <sup>13</sup> / <sub>16</sub>	19 <sup>1</sup> / <sub>8</sub>	22 <sup>1</sup> / <sub>16</sub>	21 <sup>1</sup> / <sub>8</sub>	21	49 <sup>5</sup> / <sub>8</sub>
4200	19 <sup>1</sup> / <sub>4</sub>	11	19 <sup>13</sup> / <sub>16</sub>	19 <sup>1</sup> / <sub>8</sub>	22 <sup>1</sup> / <sub>16</sub>	21 <sup>1</sup> / <sub>8</sub>	21	49 <sup>5</sup> / <sub>8</sub>
4800	22 <sup>3</sup> / <sub>4</sub>	11	19 <sup>13</sup> / <sub>16</sub>	22 <sup>1</sup> / <sub>16</sub>	22 <sup>1</sup> / <sub>16</sub>	24 <sup>1</sup> / <sub>16</sub>	24	53 <sup>7</sup> / <sub>16</sub>
6000	22 <sup>3</sup> / <sub>4</sub>	11	19 <sup>13</sup> / <sub>16</sub>	22 <sup>1</sup> / <sub>16</sub>	22 <sup>1</sup> / <sub>16</sub>	24 <sup>1</sup> / <sub>16</sub>	24	59 <sup>3</sup> / <sub>16</sub>
FXM (mm)								
Unit Size	A	B	C	D	E	F	G	H
1800	400	279	503	397	560	448	533	1261
2400	400	279	503	397	560	448	533	1261
3000	489	279	503	486	560	537	533	1357
3600	489	279	503	486	560	537	533	1261
4200	489	279	503	486	560	537	533	1261
4800	578	279	503	576	560	627	610	1357
6000	578	279	503	576	560	627	610	1503

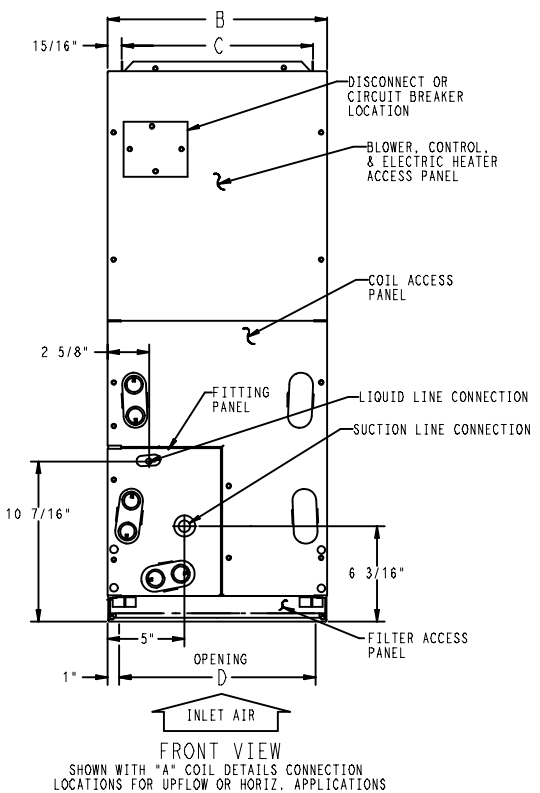
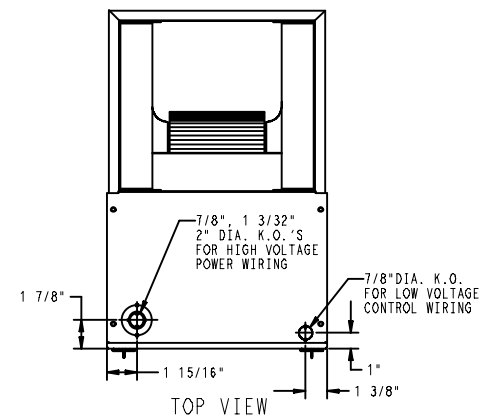

**UNIT CONNECTION SIZES**  
 SUCTION: 18 & 24 - 5/8" I.D. SWEAT  
 30 THRU 36 - 3/4" I.D. SWEAT  
 42 THRU 60 - 7/8" I.D. SWEAT  
 LIQUID: 3/8" I.D. SWEAT  
 CONDENSATE: 3/4" FPT

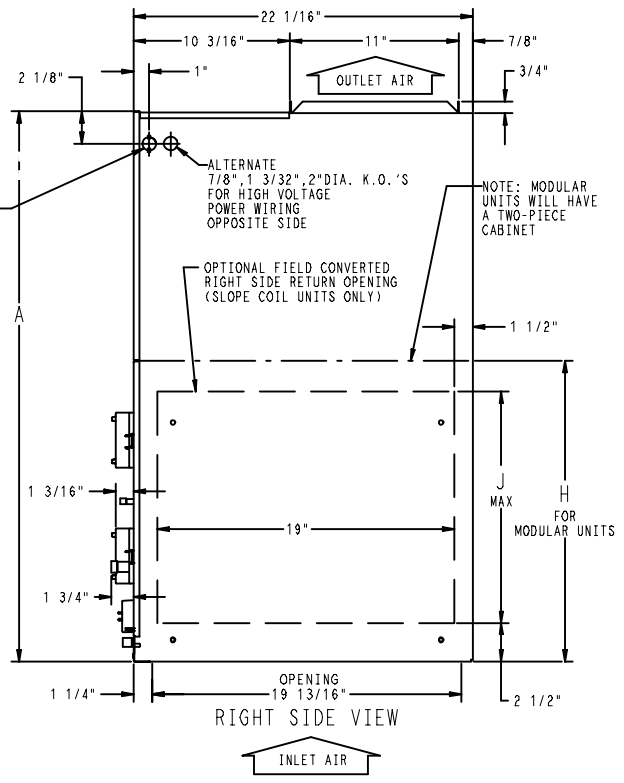
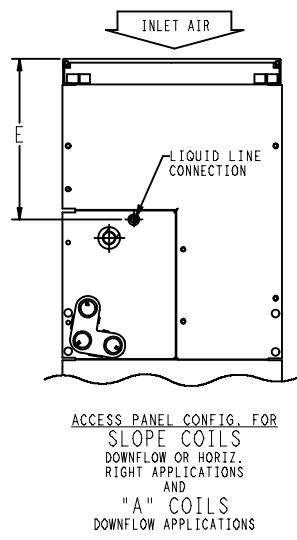
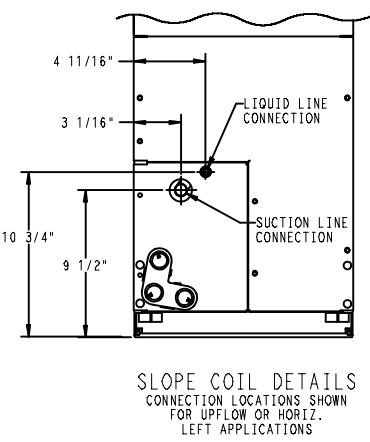

SD4874-4\_1\_A

Dimensions Inches (English)

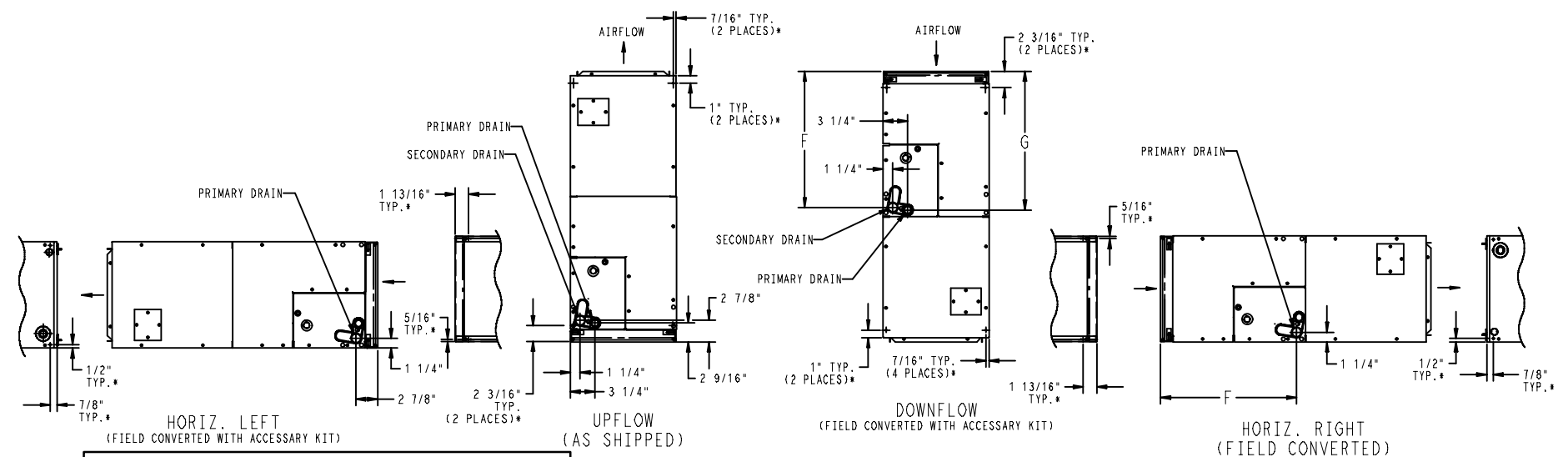

\* HORIZONTAL MOUNT LOCATIONS - DIMPLES PROVIDED IN TOP PANEL, AND BACK OF CABINET. IN CABINET BOTTOM, HOLES PROVIDED .136" DIA. HORIZONTAL HANGING HARDWARE TO BE FIELD SUPPLIED.

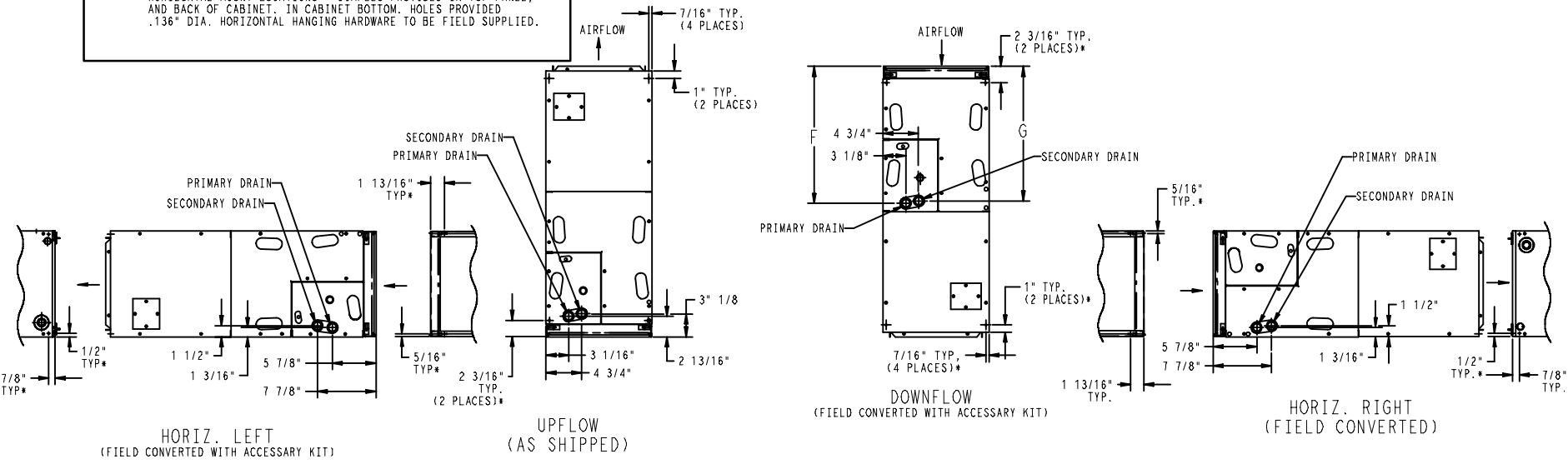

Dimensions Inches (English)

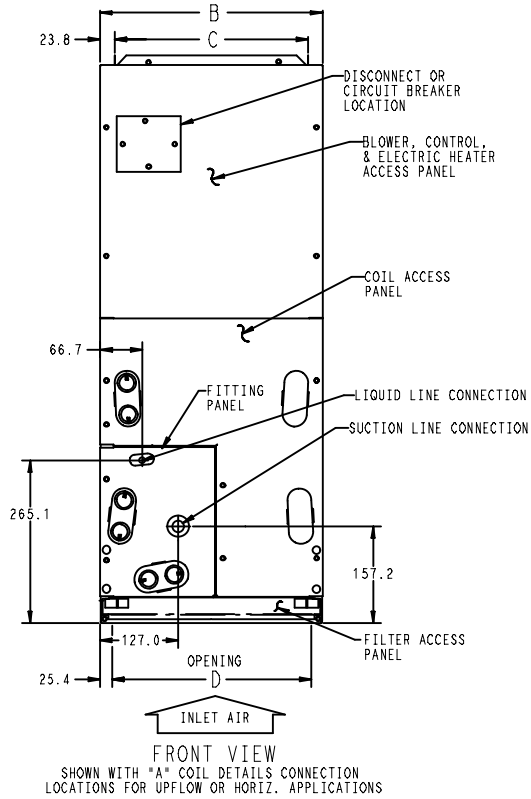
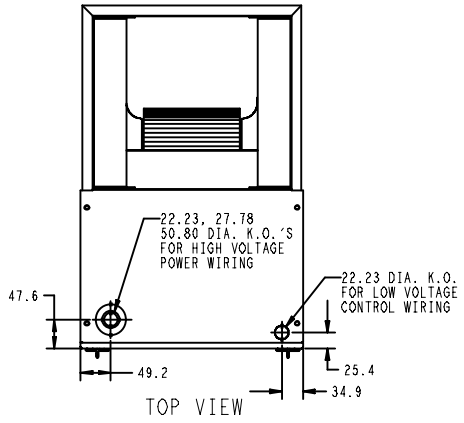

UNIT CONNECTION SIZES

SUCTION: 18 & 24 - 15.88 I.D. SWEAT  
30 THRU 36 - 19.05 I.D. SWEAT  
42 THRU 60 - 22.23 I.D. SWEAT  
LIQUID: 9.53 I.D. SWEAT  
CONDENSATE: 19.0 FPT

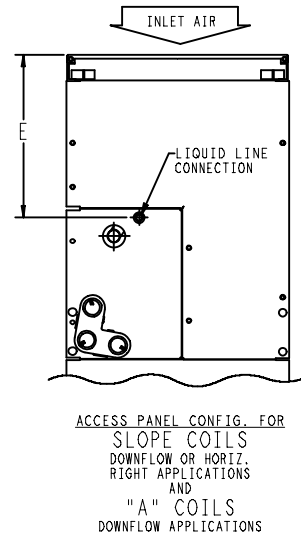
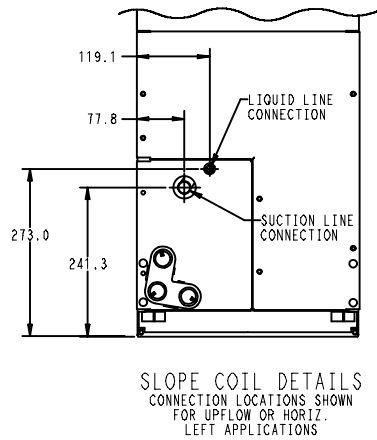

NOTE: ALLOW 533.4 FROM FRONT  
FOR SERVICE

ALTERNATE  
22.23 DIA. K.O.  
FOR LOW VOLTAGE  
CONTROL WIRING

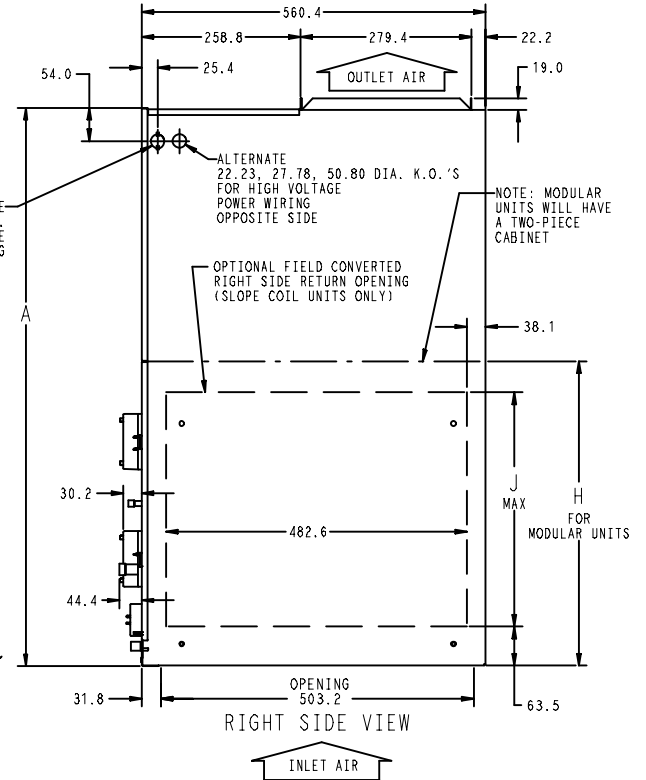

Dimensions MM (SI Metric)

# SLOPE COIL

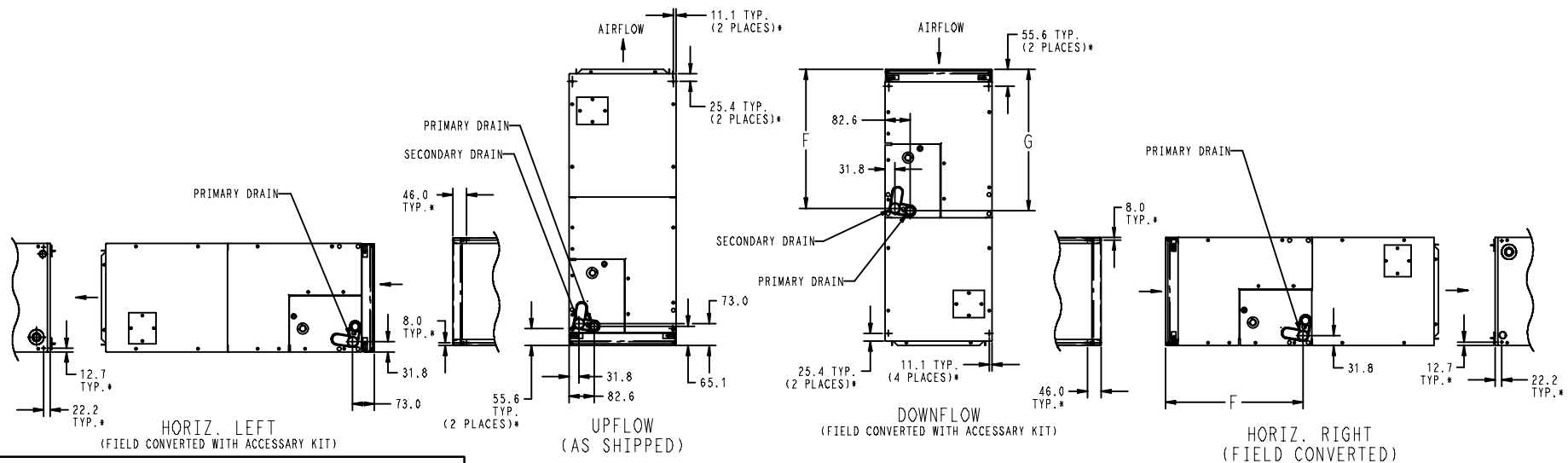

\* HORIZONTAL MOUNT LOCATIONS - DIMPLES PROVIDED IN TOP PANEL, AND BACK OF CABINET. IN CABINET BOTTOM, HOLES PROVIDED 3.45 DIA. HORIZONTAL HANGING HARDWARE TO BE FIELD SUPPLIED.

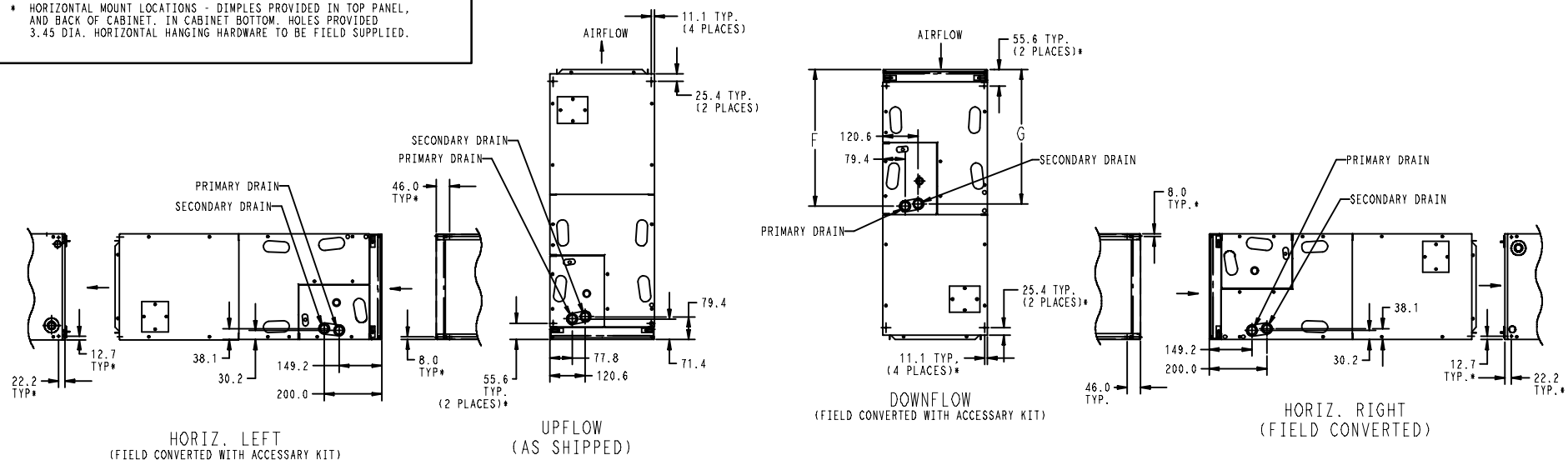

# A-COIL

Dimensions MM (SI Metric)

DIMENSIONAL DATA (refer to drawings on previous pages)														
Model	Size (tons)	Dimensions Inches											Coil Type	Ship. Weight (lbs)
		A	B	C	D	E	F	G	H	J	Suct.	Liquid		
FXM4X1800A	1½	49⅝	17⅝	15¾	15⅝	15⅝	23⅛	23⅝	–	17	⅝	⅜	Slope	122
FXM4X2400A	2	49⅝	17⅝	15¾	15⅝	15⅝	23⅛	23⅝	–	17	⅝	⅜	Slope	122
FXM4X3000A	2½	53⅞	21⅞	19¼	19⅞	19¾	26⅛	27½	–	19	¾	⅜	Slope	146
FXM4X3600A	3	49⅝	21⅞	19¼	19⅞	15⅞	23⅞	23⅞	–	–	¾	⅜	“A”	157
FXM4X4200A	3½	49⅝	21⅞	19¼	19⅞	15⅞	23⅞	23⅞	–	–	¾	⅜	“A”	157
FXM4X4800A	4	53⅞	24⅞	22¾	22⅞	19½	27¼	26⅛	–	–	¾	⅜	“A”	185
FXM4X6000A	5	59⅞	24⅞	22¾	22⅞	25¼	32⅞	32⅞	–	–	¾	⅜	“A”	201

DIMENSIONAL DATA (refer to drawings on previous pages)														
Model	Size (tons)	Dimensions MM											Coil Type	Ship. Weight (kg)
		A	B	C	D	E	F	G	H	J	Suct.	Liquid		
FXM4X1800A	1½	1261	448	400	397	391	587	600	–	432	16	10	Slope	55
FXM4X2400A	2	1261	448	400	397	391	587	600	–	432	16	10	Slope	55
FXM4X3000A	2½	1357	537	489	486	487	684	699	–	483	19	10	Slope	66
FXM4X3600A	3	1261	537	489	486	399	595	587	–	–	19	10	“A”	71
FXM4X4200A	3½	1261	537	489	486	399	595	587	–	–	22	10	“A”	71
FXM4X4800A	4	1357	627	578	576	495	692	684	–	–	22	10	“A”	84
FXM4X6000A	5	1503	627	578	576	641	837	829	–	–	22	10	“A”	91

PHYSICAL DATA							
	Model Size						
	1800	2400	3000	3600	4200	4800	6000
<b>TXV factory installed, hard shut-off, bi-flow type for heat pump application</b>							
FXM4X	4 ton		3 ton	4 ton			
<b>Blower Data</b>							
CFM nominal (L/s)	600 (283)	800 (378)	1000 (472)	1200 (566)	1400 (661)	1600 (755)	2000 (944)
Motor Type	Genteq™ X-13 (BPM, ECM)						
HP	1/3	1/3	1/2	1/2	1/2	3/4	3/4
<b>Filter Data</b>							
Filter Size in. (mm)	16⅞ x 21½ (416 x 546)		19⅞ x 21½ (505 x 546)		23⅞ x 21½ (592 x 546)		
<b>Coil Data (all coils 14½ fins per inch, wavy lanced bare aluminum fin)</b>							
Face Area ft² (m²)	2.97 (0.28)	2.97 (0.28)	3.46 (0.32)	4.45 (0.41)		5.93 (0.55)	7.42 (0.69)
<b>Refrigerant Line Connections (sweat)</b>							
Liquid inch (mm)	3/8 (10)	3/8 (10)	3/8 (10)	3/8 (10)	3/8 (10)	3/8 (10)	3/8 (10)
Suction inch (mm)	5/8 (16)	5/8 (16)	3/4 (19)	3/4 (19)	7/8 (22)	7/8 (22)	7/8 (22)

**ELECTRICAL DATA, FAN COIL ONLY WITHOUT ELECTRIC HEAT**

Model	208/230V, single phase, 60 Hz		
	Motor Full Load Amps (FLA)	Minimum Circuit Ampacity (MCA)	Maximum Fuse/Ckt Bkr Amps (Max OverCurrent Protection – MOCP)
FXM4X1800	2.8	3.5	15
FXM4X2400	2.8	3.5	15
FXM4X3000	4.1	5.1	15
FXM4X3600	4.1	5.1	15
FXM4X4200	4.1	5.1	15
FXM4X4800	6.0	7.5	15
FXM4X6000	6.0	7.5	15

**AIRFLOW PERFORMANCE – CFM at a given Speed and Static reading**

Model	Blower Speed	Measured Static Pressure, inlet to outlet (inches water column)					
		0.10	0.20	0.30	0.40	0.50	0.60
FXM4X1800	Tap 5	776	745	696	660	609	572
	Tap 4	683	644	589	548	494	461
	Tap 3	683	644	589	548	494	461
	Tap 2	631	563	500	443	409	361
	Tap 1	625	524	457	417	367	319
FXM4X2400	Tap 5	956	920	891	851	816	780
	Tap 4	825	795	757	722	674	634
	Tap 3	825	795	757	722	674	634
	Tap 2	726	695	635	598	543	509
	Tap 1	631	563	500	443	409	361
FXM4X3000	Tap 5	1189	1151	1104	1050	1003	959
	Tap 4	1041	998	944	886	837	772
	Tap 3	1041	998	944	886	837	772
	Tap 2	924	876	817	752	704	660
	Tap 1	779	693	628	571	526	476
FXM4X3600	Tap 5	1363	1332	1294	1253	1207	1157
	Tap 4	1237	1206	1160	1121	1070	1013
	Tap 3	1237	1206	1160	1121	1070	1013
	Tap 2	1095	1058	1007	951	888	824
	Tap 1	1014	885	773	673	609	549
FXM4X4200	Tap 5	1519	1490	1454	1419	1379	1332
	Tap 4	1437	1403	1366	1333	1294	1245
	Tap 3	1437	1403	1366	1333	1294	1245
	Tap 2	1257	1226	1191	1141	1090	1033
	Tap 1	1237	1206	1160	1121	1070	1013
FXM4X4800	Tap 5	1757	1725	1693	1653	1614	1576
	Tap 4	1664	1626	1593	1552	1517	1477
	Tap 3	1664	1626	1593	1552	1517	1477
	Tap 2	1459	1420	1379	1336	1298	1259
	Tap 1	1301	1241	1195	1150	1102	1039
FXM4X6000	Tap 5	2030	1995	1961	1927	1888	1842
	Tap 4	1811	1775	1740	1703	1664	1613
	Tap 3	1811	1775	1740	1703	1664	1613
	Tap 2	1665	1632	1593	1556	1507	1453
	Tap 1	1462	1418	1371	1327	1278	1228

NOTES:

- Airflow based upon dry coil at 230v with factory approved filter and electric heater (2 element heater sizes 18 through 36, 3 element heater sizes 42 through 60).
- Airflow at 208 volts is approximately the same as 230 volts because the X13 motor is a constant torque motor. The torque doesn't drop off at the speeds the motor operates.
- To avoid potential for condensate blowing out of drain pan prior to making drain trap: Return static pressure must be less than 0.40 in. wc. Horizontal applications of 043 – 061 sizes must have supply static greater than 0.20 in. wc.
- Airflow above 400 cfm/ton on 049 – 061 size could result in condensate blowing off coil or splashing out of drain pan.
- Shading – Airflow outside 450 cfm/ton.



STATIC PRESSURE DROP ACROSS FILTER (inches of water column)									
Model Size	CFM								
	400	600	800	1000	1200	1400	1600	1800	2000
1800	.020	.044	.075	-	-	-	-	-	-
2400	-	.022	.048	.072	.100	-	-	-	-
3000	-	.022	.048	.072	.100	-	-	-	-
3600	-	-	-	.051	.070	.092	.120	.152	-
4200	-	-	-	.051	.070	.092	.120	.152	-
4800	-	-	-	.051	.070	.092	.120	.152	-
6000	-	-	-	-	-	-	.086	.105	.130

STATIC PRESSURE CORRECTION FROM DRY TO WET COIL (inches of water column)																
Airflow performance chart on pages NO TAG-NO TAG was developed using fan coils with DRY coils. When taking a static reading across a WET coil, adjust the static pressure numbers on pages NO TAG-NO TAG by <b>adding</b> the values in this table (for a given CFM, wet coil will have greater static pressure drop than dry coil).																
Model Size	CFM															
	500	600	700	800	900	1000	1100	1200	1300	1400	1500	1600	1700	1800	1900	2000
1800	.034	.049	.063	-	-	-	-	-	-	-	-	-	-	-	-	-
2400	.016	.027	.038	.049	.059	-	-	-	-	-	-	-	-	-	-	-
3000	-	-	-	.049	.059	.070	.080	-	-	-	-	-	-	-	-	-
3600	-	-	-	-	-	.055	.064	.073	.081	-	-	-	-	-	-	-
4200	-	-	-	-	-	-	-	.049	.056	.063	.070	-	-	-	-	-
4800	-	-	-	-	-	-	-	-	-	.038	.043	.049	.054	.059	-	-
6000	-	-	-	-	-	-	-	-	-	-	-	.027	.031	.035	.039	.043

ACCESSORIES		
Description	Part Number	Use with model size
Disconnect Kit	EBAC01DSC	use with All Heaters 5 kW thru 10 kW
Downflow Base Kit	EBAC01NCB	1800
	EBAC02NCB	2400, 3000
	EBAC03NCB	3600, 4200, 4800
	EBAC04NCB	6000
Downflow Conversion Kit – Slope Coil	EBAC01DFS	1800, 2400, 3000
Downflow Conversion Kit – “A” Coil	EBAC02DFA	3600, 4200, 4800, 6000
Single Point Wiring Kit	EBAC01SPK	only for use with 15 kW & 20 kW fused heaters
Single Point Wiring Kit – Square D® Jumper Bar Assembly	AMFK20SPA or Square D® part # QOU14100JBAF	Only for use with EHK15AKB and EHK20AKB breaker heaters
Permanent Filter Kit (box of 12)	EBAC01FKM	1800, 2400
	EBAC01FKL	3000, 3600, 4200
	EBAC01FKX	4800, 6000
No Heat (Plug) Kit (box of 6)	EBAC01PLG	Factory Installed
PVC Condensate Trap Kit (box of 50)	EBAC01CTK	ALL
Horizontal Gasket Kit	EBAC01GSK	ALL (required for horizontal right and downflow)

ELECTRIC HEATERS		
Part Number	Description	Use with Model Sizes
EHK05AKN	5 kW, single phase, no internal circuit protection	ALL
EHK05AKB	5 kW, single phase, with circuit breakers	ALL
EHK07AKN	8 kW, single phase, no internal circuit protection	ALL
EHK07AKB	8 kW, single phase, with circuit breakers	ALL
EHK09AKCN	9 kW, supplied as single phase, field convertible to 3-phase, no internal circuit protection	3600, 4200, 4800, 6000
EHK10AKN	10 kW, single phase, no internal circuit protection	ALL
EHK10AKB	10 kW, single phase, with circuit breakers	ALL
EHK15AKF	15 kW, single phase, with fuses	2400, 3000, 3600, 4200, 4800, 6000
EHK15AKB	15 kW, single phase, with circuit breakers	2400, 3000, 3600, 4200, 4800, 6000
EHK15AHN	15 kW, 3-phase, no internal circuit protection	3600, 4200, 4800, 6000
EHK18AHN	18 kW, 3-phase, no internal circuit protection	4200, 4800, 6000
EHK20AKF	20 kW, single phase, with fuses	3000, 3600, 4200, 4800, 6000
EHK20AKB	20 kW, single phase, with circuit breakers	3000, 3600, 4200, 4800, 6000
EHK25AHCF	24 kW, supplied as 3-phase, field convertible to single phase, with fuses	4800, 6000
EHK30AHCF	30 kW, supplied as 3-phase, field convertible to single phase, with fuses	4800, 6000

**STATIC PRESSURE CORRECTION FOR ELECTRIC HEATERS (inches of water column)**

Airflow performance chart on pages NO TAG-NO TAG was developed using fan coils with 10 kW electric heater (2 elements) in the 1800 – 3600 model sizes, and 15 kW electric heaters (3 elements) in the 4200 – 6000 model sizes. When using a different number of heater elements, adjust the static pressure numbers on pages NO TAG-NO TAG by adding or subtracting the values in this table (for a given CFM, more electric heater elements create higher static pressure drop).

Model Size	Heater kW				
	No Heater	3 or 5	8 or 10	9 or 15	20
	Number of Heat Elements				
	0	1	2	3	4
1800	+0.02	+0.01	0	-0.02	-0.04
2400	+0.02	+0.01	0	-0.02	-0.04
3000	+0.02	+0.01	0	-0.02	-0.04
3600	+0.02	+0.01	0	-0.02	-0.04
4200	+0.04	-	+0.02	0	-0.02
4800	+0.04	-	+0.02	0	-0.02
6000	+0.04	-	+0.02	0	-0.02

**TABLE 3 - ELECTRIC HEATER ELECTRICAL DATA**

Heater Model	Heater kW		Phase	Internal Circuit Protection	Heater Amps 208/230V		Branch Circuit 208/230V						
							Minimum Circuit Ampacity (MCA) ☆				Max Fuse/Ckt Bkr Amps (Max OverCurrent Protection)		
	230V	208V			Single Circuit	Dual Circuit		Single Circuit	Dual Circuit		Single Circuit	Dual Circuit	
						L1, L2	L3, L4		L1, L2	L3, L4		L1, L2	L3, L4
EHK05AKN*	5	3.8	1	None	18.1 / 20.0	-	-	26.0 / 28.4	-	-	30 / 30	-	-
EHK05AKN**	5	3.8	1	None	18.1 / 20.0	-	-	31.2 / 33.5	-	-	35 / 35	-	-
EHK05AKB*	5	3.8	1	Ckt Bkr	18.1 / 20.0	-	-	26.0 / 28.4	-	-	30 / 30	-	-
EHK05AKB**	5	3.8	1	Ckt Bkr	18.1 / 20.0	-	-	31.2 / 33.5	-	-	35 / 35	-	-
EHK07AKN	8	6.0	1	None	28.9 / 32.0	-	-	44.7 / 48.5	-	-	45 / 50	-	-
EHK07AKB	8	6.0	1	Ckt Bkr	28.9 / 32.0	-	-	44.7 / 48.5	-	-	45 / 50	-	-
EHK09AKCN†	9	6.8	1	None	32.8 / 36.0	-	-	49.5 / 53.5	-	-	50 / 60	-	-
			3	None	18.8 / 20.8	-	-	32.0 / 34.5	-	-	35 / 35	-	-
EHK10AKN	10	7.5	1	None	36.2 / 40.0	-	-	53.8 / 58.5	-	-	60 / 60	-	-
EHK10AKB	10	7.5	1	Ckt Bkr	36.2 / 40.0	-	-	53.8 / 58.5	-	-	60 / 60	-	-
EHK15AKF	15	11.3	1	Fuse	54.2 / 59.9	36.2 / 40.0	18.1 / 20.0	76.3 / 83.4	53.8 / 58.5	22.7 / 25.0	80 / 90	60 / 60	25 / 25
EHK15AKB	15	11.3	1	Ckt Bkr	-	36.2 / 40.0	18.1 / 20.0	-	53.8 / 58.5	22.7 / 25.0	-	60 / 60	25 / 25
EHK15AHN	15	11.3	3	None	31.3 / 34.6	-	-	47.7 / 51.8	-	-	50 / 60	-	-
EHK18AHN	18	13.5	3	None	37.6 / 41.5	-	-	55.5 / 60.4	-	-	60 / 70	-	-
EHK20AKF	20	15.0	1	Fuse	72.3 / 79.9	36.2 / 40.0	36.2 / 40.0	98.9 / 108.4	53.8 / 58.5	45.3 / 50.0	100 / 110	60 / 60	50 / 50
EHK20AKB	20	15.0	1	Ckt Bkr	-	36.2 / 40.0	36.2 / 40.0	-	53.8 / 58.5	45.3 / 50.0	-	60 / 60	50 / 50
EHK25AHCF‡	24	18.0	3	Fuse	50.1 / 55.4	-	-	71.2 / 77.8	-	-	80 / 80	-	-
			1	Fuse	86.7 / 95.5	-	-	116.9 / 127.9	-	-	125 / 150	-	-
EHK30AHCF‡	30	22.5	3	Fuse	62.6 / 69.2	-	-	86.8 / 95.0	-	-	90 / 100	-	-
			1	Fuse	109 / 120	-	-	144.8 / 158.5	-	-	150 / 175	-	-

**TABLE 4 - FIELD MULTIPOINT WIRING OR 24 AND 30 KW SINGLE PHASE**

Heater Model	Heater kW		P H A S E	Heater Amps 208/230V			Minimum Circuit Ampacity 208/230V ☆			Minimum Wire Size (AWG) 208/230V‡			Min Gnd Wire Size 208/230V	Max Fuse/Ckt Bkr Amps 208/230V			Max Wire Length 208/230V (FT)‡‡		
	230V	208V		L1, L2	L3, L4	L5, L6	L1, L2	L3, L4	L5, L6	L1, L2	L3, L4	L5, L6		L1, L2	L3, L4	L5, L6	L1, L2	L3, L4	L5, L6
EHK25AHCF‡	24	18.0	1	28.9/32.0	28.9/32.0	28.9/32.0	44.7/48.5	36.2/40.0	36.2/40.0	8/8	8/8	8/8	10/10	45/50	40/40	40/40	59/60	73/73	73/73
EHK30AHCF‡	30	22.5	1	36.2/40.0	36.2/40.0	36.2/40.0	53.8/58.5	45.3/50.0	45.3/50.0	6/6	8/8	8/8	10/10	60/60	50/50	50/50	78/80	59/59	59/59

Notes:

- \* When used with Fan Coil model sizes 2400, 3600
- \*\* When used with Fan Coil model sizes 4200, 4800, 6000
- ☆ Includes blower motor amps of largest Fan Coil used with heater
- † Supplied as single phase, field convertible to 3-phase
- ‡ Supplied as 3-phase, field convertible to single phase, single or multiple supply circuits
- ‡‡ Length shown is as measured one way along wire path between unit and service panel for a voltage drop not to exceed 2%

**FAN COIL MODEL NUMBER IDENTIFICATION GUIDE**

	<b>F</b>	<b>X</b>	<b>M</b>	<b>4</b>	<b>X</b>	<b>1800</b>	<b>A</b>	<b>1</b>
F = Fan Coil		<b>MOTOR TYPE</b>		<b>INSTALLATION TYPE</b>		<b>REFRIGERANT</b>		<b>METERING DEVICE</b>
X = Genteq™ X-13		M = Multiposition		4 = Environmentally Sound R-410A		X = TXV		<b>NOMINAL CAPACITY</b>
1800 = 18,000 BTUH = 1½ tons		2400 = 24,000 BTUH = 2 tons		3000 = 30,000 BTUH = 2½ tons		3500 & 3600 = 36,000 BTUH = 3 tons		
4200 = 42,000 BTUH = 3½ tons		4800 = 48,000 BTUH = 4 tons		6000 = 60,000 BTUH = 5 tons				
Sales Code		Engineering Revision						

**ACCESSORIES PART NUMBER IDENTIFICATION GUIDE**

	<b>EB</b>	<b>AC</b>	<b>01</b>	<b>NCB</b>	<b>A</b>
EB = Evaporator Blower		AC = Accessory		01 = Product Identifier Number	
NCB = Non-Combustible Base Kit		DFK = Down Flow Kit		PLG = Power Plug (no heat kit)	
SPK = Single Point Wiring Kit		FKS = Filter Kit Small		FKM = Filter Kit Medium	
FKL = Filter Kit Large		FKX = Filter Kit Extra Large		CTK = Condensate Trap Kit (PVC pipe)	
Sales Code					

**ELECTRIC HEATER MODEL NUMBER IDENTIFICATION GUIDE**

	<b>EHK</b>	<b>05</b>	<b>A</b>	<b>K</b>	<b>N</b>	<b>1</b>
EHK = Electric Heater Kit		<b>NOMINAL HEAT VALUE</b>		<b>VOLTAGE (60 Hz)</b>		
05 = 5 kW		07 = 7 kW		09 = 9 kW		
10 = 10 kW		15 = 15 kW		18 = 18 kW		
20 = 20 kW		25 = 25 kW		30 = 30 kW		
Sales Code		K = 208 / 230 single-phase		H = 208 / 230, 3-phase		
		KC = 208 / 230, supplied as single phase, field convertible to 3-phase		HC = 208 / 230 supplied as 3-phase, field convertible to single phase		
Product Identifier		Engineering Code				