

# INSTALLATION INSTRUCTIONS

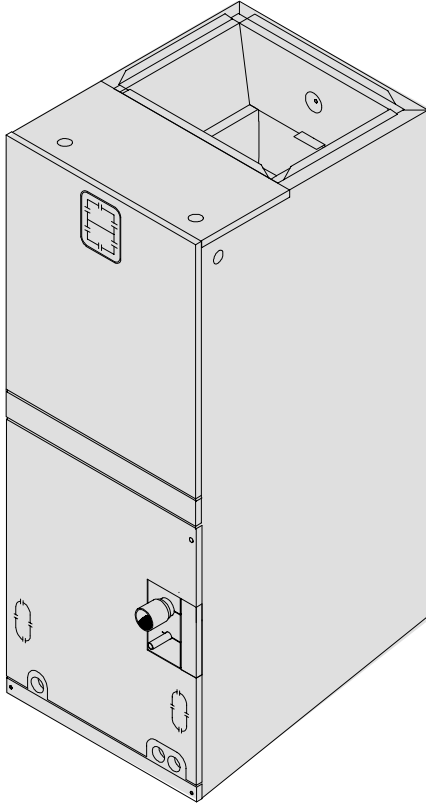

Use **ONLY** factory listed electric heaters.

## ELECTRIC FURNACE

### Models

EF08B1500A1, A2  
EF12F1900A  
EF16J2200A  
EF20N2600A

With  
AMF001NHA  
Accessory No Heat Kit

### Contents

Safety Labeling and Signal Words	Cov
General Information / Installation	2
Vertical Installations	2
Horizontal Installations	3
Condensate Drain	5
Refrigerant Orifice and Lines	5
Electrical Wiring	6
Checks and Maintenance	7
Blower Performance	8

### Safety Labeling and Signal Words

#### Danger, Warning and Caution

The signal words **DANGER**, **WARNING** and **CAUTION** are used to identify levels of hazard seriousness. The signal word **DANGER** is only used on product labels to signify an immediate hazard. The signal words **WARNING** and **CAUTION** will be used on product labels and throughout this manual and other manuals that may apply to the product.

**DANGER** - Immediate hazards which **WILL** result in severe personal injury or death.

**WARNING** - Hazards or unsafe practices which **COULD** result in severe personal injury or death.

**CAUTION** - Hazards or unsafe practices which **COULD** result in minor personal injury or product or property damage.

#### Signal Words in Manuals

The signal word **WARNING** is used throughout this manual in the following manner:

**WARNING**

The signal word **CAUTION** is used throughout this manual in the following manner:

**CAUTION**

#### Product Labeling

Signal words are used in combination with colors and/or pictures on product labels.

Figure 1 Dimensions and Clearances

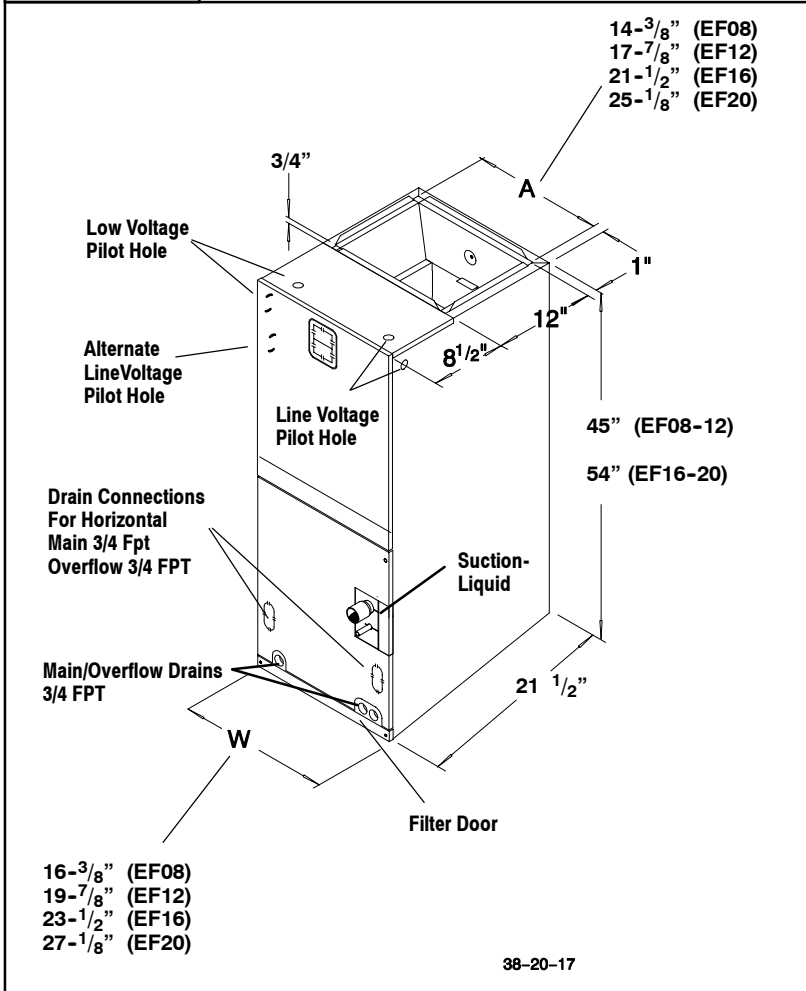

CLEARANCES	
<b>NO HEATERS</b>	
All Sides .....	0"
From Supply Duct .....	0"
Recommended Service From Front .....	20"
(Service for blower, filter if installed)	
<b>WITH HEATERS</b>	
All Sides .....	0"
From First Three Feet of Supply Duct to Combustibles .....	1"
From Duct after Three Feet .....	0"
Recommended Service From Front .....	20"
(Service for blower, filter, heaters if installed)	

**WARNING**

**Fire Hazard**

When heaters are installed maintain clearances from combustible materials as specified on unit rating plate. Do not use plastic lined or combustible flexible ducting within 36 inches of the supply end of the air handler.

Failure to do so can result in fire, property damage, personal injury and/or death.

**General Information**

**WARNING**

Installation or repairs made by unqualified persons can result in hazards to you and others. Installation **MUST** conform with local building codes and with the National Electrical Code NFPA70 current edition.

The information contained in this manual is intended for use by a qualified service technician familiar with safety procedures and equipped with the proper tools and test instruments.

Failure to carefully read and follow all instructions in this manual can result in equipment malfunction, property damage, personal injury and/or death.

**THESE INSTRUCTIONS ASSUME THAT A TYPICAL INSTALLATION WILL INCLUDE ELECTRIC HEAT AND A COIL. BASIC INSTRUCTIONS ARE PROVIDED BUT THE INSTALLER WILL HAVE TO REFER TO INSTRUCTIONS FOR OTHER ACCESSORIES FOR MORE COMPLETE INFORMATION.**

The blower cabinet may be used as an electric furnace or for cooling or heat pump operation with or without electric heat. The cabinet can be installed in an upflow, downflow or horizontal position (Figure 2). Horizontal installations require a horizontal kit for proper coil support and drain pan. Downflow installations require a subbase kit which provides proper clearances and a support to install a coil. These units are not shipped with air filters installed. Filter must be field supplied, either washable or disposal type. Washable filters are available as an accessory.

**Location**

Select the best position which suits the installation site conditions. The location should provide adequate structural support, space in the front of the unit for service access, clearance for return air and supply duct connections, space for refrigerant piping connections and condensate drain line connections, and clearance for filter removal.

**NOTE:** Internal filter can be accessed from separate filter door. If the filter can **NOT** be easily accessed, a remote filter is recommended. Refer to ACCA Manual D for remote filter sizing.

If the unit is located in an area of high humidity, nuisance sweating of casing may occur. On these installations a wrap of 2" fiberglass insulation with a vapor barrier should be used.

## Upflow Installations

The unit is ready to install in the upflow position without modifications.

The unit **MUST** be supported on the bottom **ONLY** and set on a supporting frame or shelf. Use screws through the bottom to anchor to supporting frame.

## Downflow Installations

Refer to instructions with Subbase Kit.

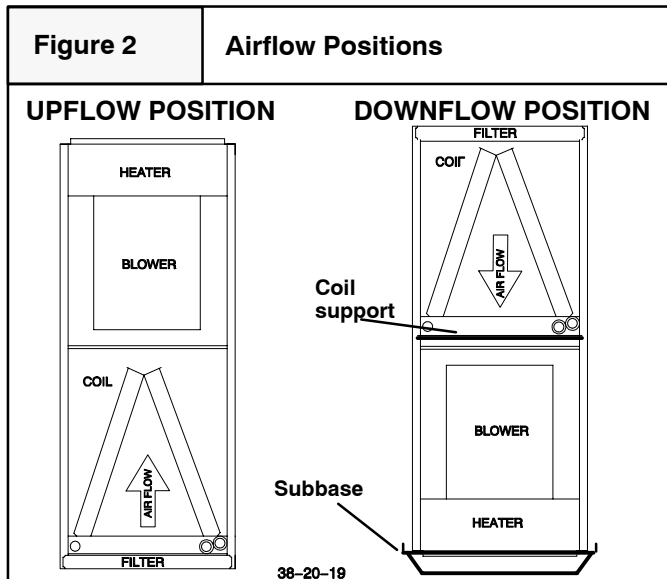

## Non-Ducted Return Air Closet Installation

The cabinet can be installed in a closet with a false bottom to form a return air plenum, or mounted on an open platform inside the closet. Platform should be high enough to provide a free (open) area for adequate return airflow into the bottom of the cabinet. The open area can be on the front side or a combination of front and sides, providing there is clearance on the sides between cabinet and closet. **Refer to ACCA Manual D for sizing and free area recommendations.**

**NOTE:** Local codes may limit application of systems without a ducted return to single story dwellings.

## Horizontal Left and Right Installations

### No Coil

If a coil is not being installed, the cabinet can be placed on either side for horizontal airflow as shipped. Refer to instructions with electric heat for instructions on horizontal applications.

### With Coil

All units must have the horizontal drain pan kit installed for either left or right hand applications. For installation of the drain pan, refer to the installation instructions included with the horizontal drain pan kit, and the following.

## CAUTION

**A field-fabricated auxiliary drain pan, with a separate drain is REQUIRED for all installations over a finished living space or in any area that may be damaged by overflow from the main drain pan. In some localities, local codes require an auxiliary drain pan for ANY horizontal installation.**

Figure 3

Airflow Positions

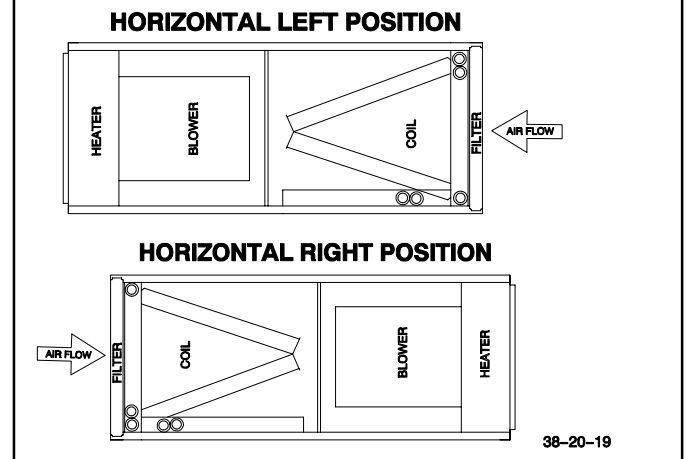

## Drain Pan Installation

1. Position side of coil drain pan into horizontal drain pan trough on deep end of pan.
2. Install the coil support bracket on left or right side of the cabinet.
3. Install coil drip flanges on the left or right side of the coil, (same side as horizontal drain pan).
5. Install drain plugs as required in back side of horizontal drain pan. Install plugs in A coil drains to prevent air leaks.
5. Slide coil assembly into cabinet being careful not to tear insulation.

**NOTE:** Be sure A coil pan fits into the support bracket on the back side of the cabinet and that pan is under the flange of the bracket on the right side. The brackets fit over the top edge of the A coil drain pan to hold it when it's put into the horizontal position.

6. Refer to Restrictor Orifice Selection and change restrictor if necessary, then install coil access panel.

Cabinet can now be placed on it's side for horizontal airflow.

## Suspended Cabinet Installation

1. If the cabinet cannot be supported on a frame or shelf, it may be suspended.
2. Use metal strapping or threaded rod with angle iron supports under the auxiliary drain pan to suspend cabinet. These supports **MUST** run parallel with the length of the cabinet (**Figure 5**).
3. Ensure that there is adequate room to remove service and access panels after installing supporting brackets.
4. Place Styrofoam blocks in auxiliary drain pan to support cabinet.

## Duct Connections

### Supply Duct

Supply duct must be attached to the outside of flange on outlet end of unit. Flexible connectors may be used if desired. Maintain clearances from supply duct to combustibles when heaters are installed. See **Figure 1** and unit rating plate.

### Return Duct

Return duct should be attached to bottom of unit using sheet metal screws or other fasteners.

Figure 4

Horizontal Drain Pan

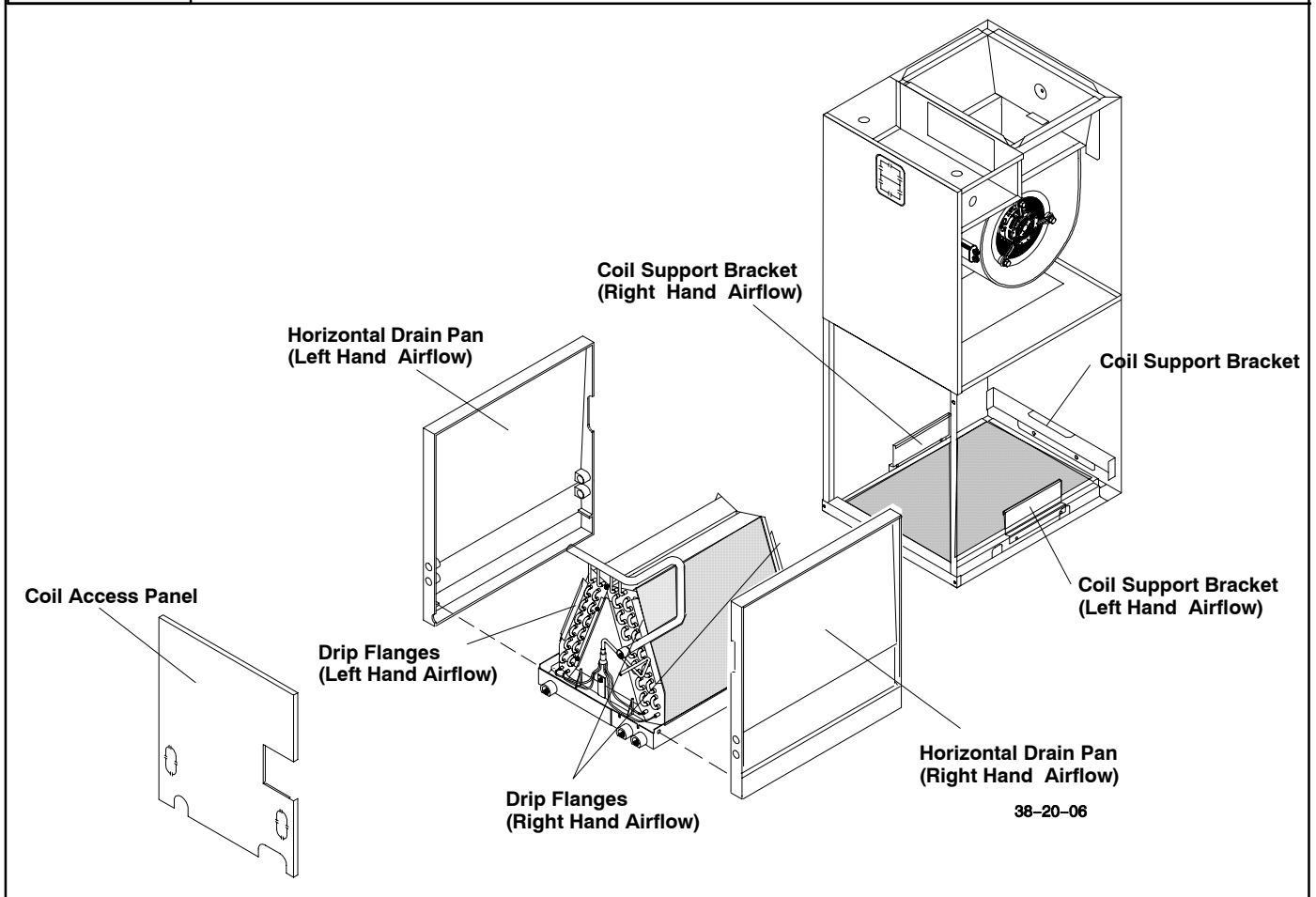
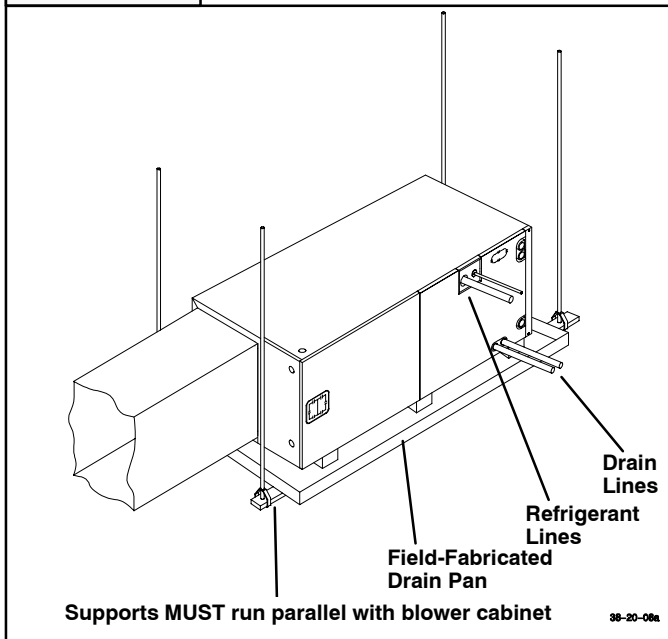

Figure 5

Horizontal Installation



### Filter Installation

Filters must be field supplied. The blower cabinet is set up for an internal filter or a remote filter grille or other means may be provided. Refer to ACCA Manual D for remote filter sizing.

To install an internal filter, remove screw securing filter door and slide filter into unit. Some filters are marked for airflow direction, make sure arrow points towards blower if marked. Washable filters are offered as an accessory. Disposable filter sizes are listed in Filter Static Pressure Drop Table.

## Condensate Drain

The unit is provided with 3/4" National Pipe Thread (NPT) condensate drains. (Figure 1). Any drain can be used as a primary or secondary drain. Condensate drain lines should be installed in a manner that does not obstruct access to the filter.

There is a secondary drain fitting supplied with the unit that will convert any of the primary condensate drain connections into a secondary drain connection. This fitting should be installed in any of the primary drain connections to convert it to a secondary drain.

1. Connect the drain lines to the appropriate drain fittings. 3/4" PVC or other type of drain line may be used. The drain line must not be smaller than the drain fitting.
2. Install a trap in the drain line below the bottom of the drain pan and pitch the drain lines down from the coil at least 1/4" per foot of run. Horizontal runs over 15 feet long must also have an anti-siphon air vent (stand pipe), installed ahead of the horizontal run. An extremely long horizontal run may require an oversized drain line to eliminate air trapping.
3. Route to the outside or to a floor drain, laundry tray or waste line (sewer). Check local codes before connecting to a sewer line.
4. Insulate drain lines where sweating could cause water damage.
5. If a gravity drain cannot be used, install a condensate pump. Install the pump as close to the indoor section as possible.

## Restrictor Orifice Selection

A restrictor orifice is located in a fitting at the distributor. The factory installed restrictor orifice is identified on the unit rating plate.

The restrictor orifice may require changing to obtain best performance. Refer to the restrictor charts furnished with the outdoor unit.

### Changing Restrictor Orifice

1. Remove the liquid line fitting and replace restrictor orifice. (STANDARD RIGHT HAND THREAD)
2. Make sure the restrictor is installed with the rounded end toward the feeder tubes. See Figure 7.

## Refrigerant Line Connections

Size refrigerant lines according to information provided with outdoor condensing unit. Route the refrigerant lines to the coil in a manner that will not obstruct service access to the unit or removal of the filter.

1. Remove rubber plugs from refrigerant connections using a pulling and twisting motion. Hold refrigerant lines to avoid bending or distorting.
2. Remove the coil door before brazing refrigerant connections to prevent damage to paint finish.
3. Fit refrigerant lines into coil connections and remove the tubing plate and slide plate over the refrigerant lines to assure sufficient room for brazing.
4. Reinstall tubing plate and door and install the gasket, provided with the unit, over the suction and liquid lines into the tubing plate recess to ensure an air seal around the coil. See Figure 8.

## Special Note For Downflow Installations

For downflow installations, a secondary overflow drain connection must be installed to prevent water from dripping onto live electrical components. Use the secondary fitting on the evaporator coil.

### Waste Line Connection

If the condensate line is to be connected to a waste line, an open trap must be installed ahead of the waste line to prevent escape of sewer gases. NEVER CONNECT THE DRAIN LINE DIRECTLY TO A WASTE LINE. ALWAYS INCLUDE AN AIR GAP AND TRAP, (Figure 6). Be sure to keep the trap filled with water during the winter or off season.

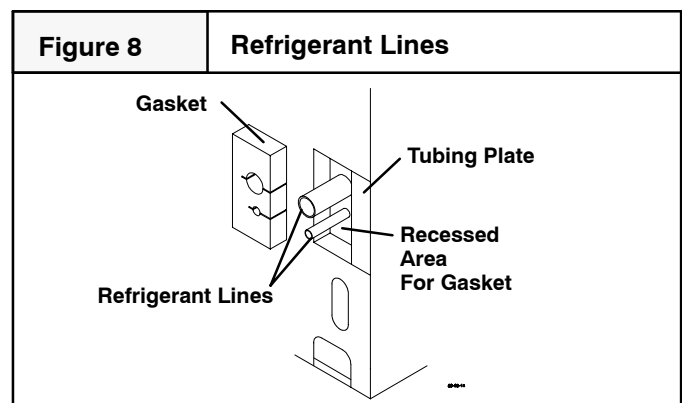
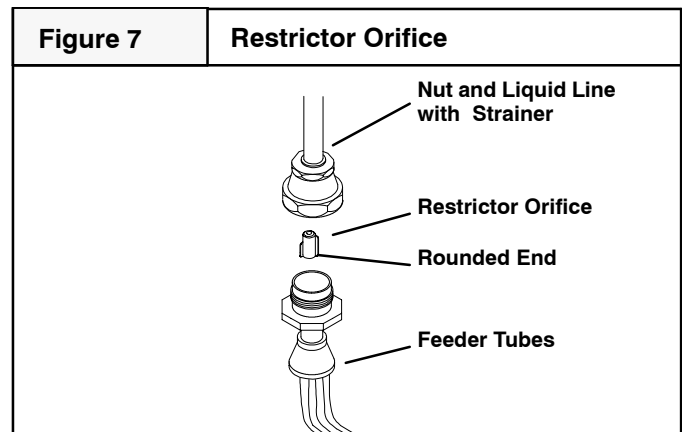
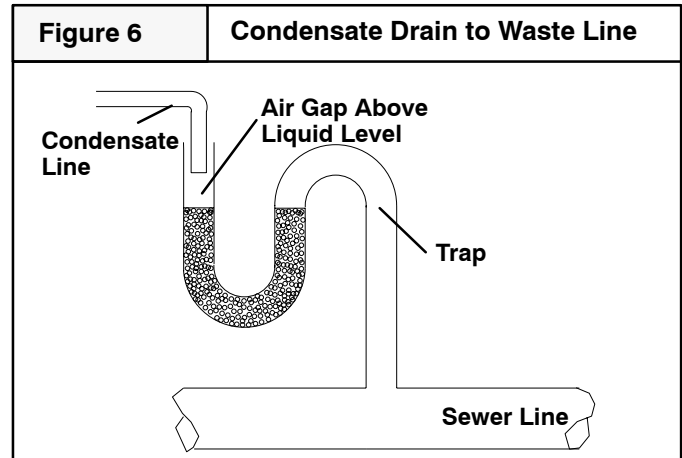

## Electric Heat

Refer to Electric Heat Installation Manual to install heaters.

## Electrical Wiring

### WARNING

Electrical shock hazard.

Turn OFF electric power at fuse box or service panel before making any electrical connections and ensure a proper ground connection is made before connecting line voltage.

Failure to do so can result in property damage, personal injury and/or death.

All electrical work MUST conform with the requirements of local codes and ordinances and the National Electrical Code NFPA 70 current edition.

### Electrical Heaters & Operating Controls

The low voltage transformer and the fan control are standard on all models and are prewired at the factory. To operate the blower coil, a heater accessory or a no-heat kit must be installed. Line voltage connections are made to the heater accessory or the no-heat kit.

#### Low Voltage Control Connections

The 24 volt power supply is provided by an internally wired low voltage transformer which is standard on all models. If power supply is 208 volt, the low voltage transformer must be rewired to the 208 volt tap. See the unit wiring label.

Field supplied low voltage wiring can enter the unit on the top left hand corner or the left hand side panel. When using the left hand side panel entrance, the low voltage wiring must be fed through the entrance hole in the bottom of the control box.

Install the strain relief bushing (supplied with unit) in the selected hole and a hole plug (supplied with unit) in the unused hole.

Connect the field wiring at the screw terminals of the control board. Refer to **Figure 9**.

Keep the low voltage wiring as short as possible inside the control box.

Complete connections between indoor blower, outdoor section, indoor thermostat and electronic outdoor thermostat (accessory) according to instruction provided with the Condenser Installation Instructions or those provided with the accessory and refer to **Figure 10**.

#### Install No Heat Kit

If electric heat is not used, install accessory No Heat Kit.

1. Locate adapter and filler plates, with screws inside package.
2. Attach adapter plate and filler plate to bracket if required to match cabinet, Refer to **Figure 9**.
3. Secure the electric heat accessory with four screws.
4. Connect the plug from No Heat Kit wiring into the receptacle on the control board on the side of the cabinet.

#### Overcurrent Protection

The power supply wiring to the unit **MUST** be provided with over-current protection. Governing codes may require this to be fuses **ONLY** or circuit breakers.

For blower cabinets without heaters, a 15 amp circuit may be used.

#### Line Voltage Connections

Line voltage wiring may be brought into the unit through the top right-hand corner or the right-hand side panel. The correct hole size required by the conduit fitting must be punched at the pilot hole location. Plug the unused pilot hole with a hole plug (supplied with unit). Refer to **Figure 9** for line voltage connections.

#### Grounding

Use a copper conductor (#14AWG) from the unit to a grounded connection in the electric service panel or a properly driven and electrically grounded ground rod.

#### Line Voltage Connection

1. A disconnect switch **MUST** be located within sight of the unit.
2. Provide line voltage power supply (208V-240V) from a separate 15 amp circuit.
3. Connect line voltage L1 and L2 to the lugs on the No Heat Kit, **Figure 9**.

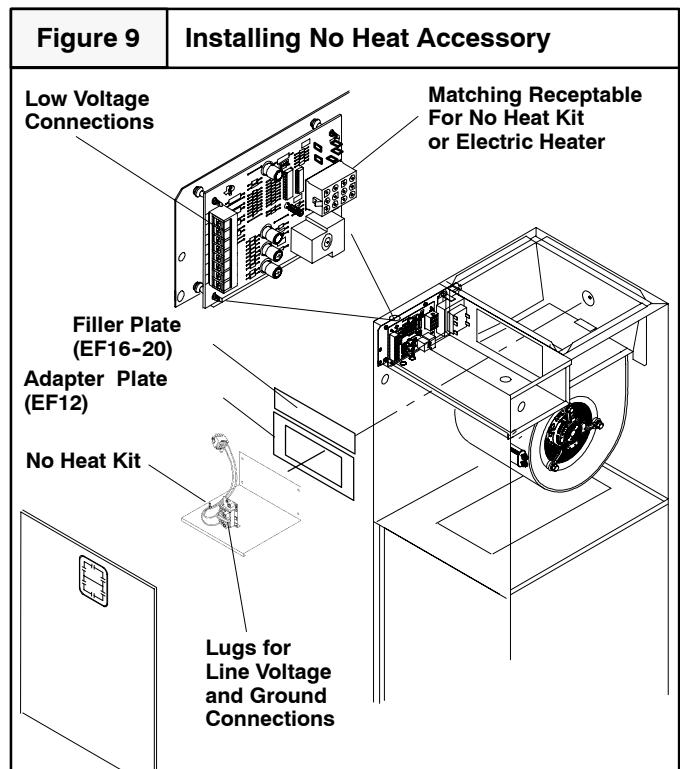

#### No Heat Kit Technical Data

No Heat Model	Supply Circuit			Supply Circuit No.	Maximum Motor AMPS.	Total AMPS.	Branch Circuit Ampacity	Maximum Overcurrent Protective Device (AMPS.)	Recommended				
									Supply Wire 75 ° C. Copper			Ground Wire	
	Volts	Phase	Hertz						No.	Size	Max. Length (Ft)	No.	Size
AMF001NH	240	1	60	Single	6.0	6.0	7.5	15	2	14	104	1	14
	208	1	60	Single	6.0	6.0	7.5	15	2	14	90	1	14

### Changing Motor Speed

The blower motor comes from the factory wired for medium or high speed. To change the blower speed, disconnect the black wire at the blower motor terminal block and reconnect at the desired blower speed tap.

**Figure 10** Typical Low Voltage Connections

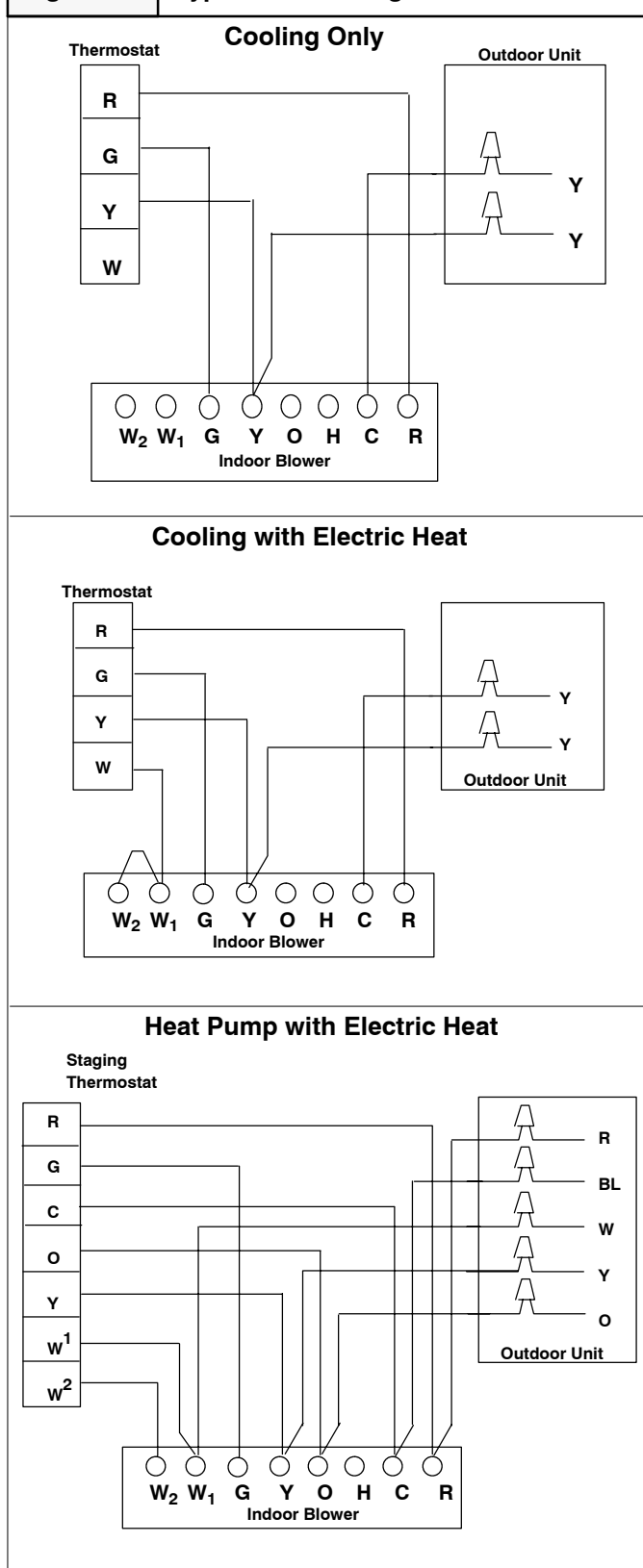

### Air Flow Check

For proper system operation, the air flow through the indoor coil should be between 350 and 450 cfm per ton of cooling capacity. The air flow through the unit can be determined by measuring the external static pressure to the unit and selecting the motor speed tap that will most closely provide the required air flow.

1. Set up to measure external static pressure at the supply and return duct connections (**Figure 11**).
2. Drill holes in the ducts for pressure taps, pitot tubes, or other accurate pressure sensing devices.
3. Connect these taps to a level inclined manometer or draft gauge.
4. Ensure the coil and filter are clean, and all the registers are open.
5. Determine the external static pressure with the blower operating.
6. Refer to the Air Flow Data (**Figure 6**) table to find the speed tap that will most closely provide the required air flow for the system.
7. Refer to Changing the Motor Speed in these instructions if the speed tap is to be changed.
8. Recheck the external static pressure with the new speed tap, and confirm speed tap selection.

**Figure 11** Static Pressure Check

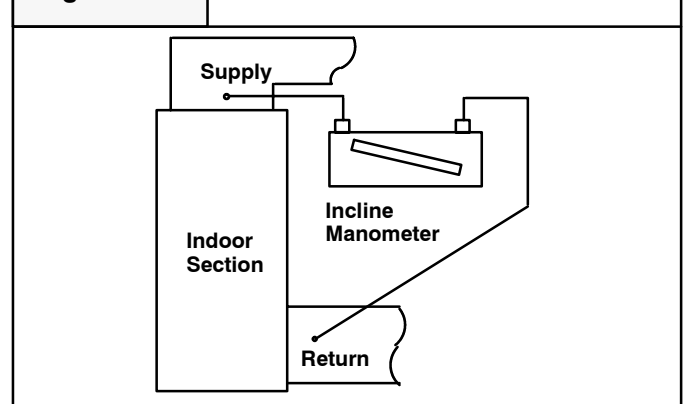

## Maintenance

### Filters

Filters must be cleaned when they become dirty. Inspect at least once per month. The frequency of cleaning depends upon the hours of operation and the local atmospheric conditions. Clean filters keep unit efficiency high.

### Lubrication

The bearings of the blower motor are permanently lubricated.

### Condensate Drains

During the cooling season check the condensate drain lines to be sure that condensate is flowing from the primary drain but not from the secondary drain. If condensate ever flows from the secondary drain the unit should be promptly shut off and the condensate pan and drains cleaned to insure a free flowing primary drain.

Airflow Based on no coil, no filter, no electric heat. Deduct heater static shown in heater static table. Deduct filter static shown in filter static table. Deduct coil static, See Coil Specification Sheet. Deduct .10 for Horizontal Drain Pan Kit. Deduct .20 for Downflow Subbase Kit.

EF08		SP IN. WG.							
SPEED	Volts	0.3	0.4	0.5	0.6	0.7	0.8	0.9	1.0
LOW	230V	1053	1013	965	911	856	761	654	552
	208V	863	827	788	725	641	568	492	381
MED	230V	1333	1281	1221	1150	1060	990	857	743
	208V	1156	1115	1059	997	941	853	738	618
HIGH	230V	1553	1486	1411	1328	1227	1106	1032	865
	208V	1394	1336	1272	1195	1096	1023	924	774

EF16		SP IN. WG.							
SPEED	Volts	0.3	0.4	0.5	0.6	0.7	0.8	0.9	1.0
LOW	230V	1103	1088	1067	1040	994	921	849	749
	208V	872	847	820	788	750	696	630	530
MED	230V	1500	1493	1470	1438	1383	1303	1143	993
	208V	1229	1223	1198	1169	1123	1031	926	798
HIGH	230V	1912	1879	1830	1771	1684	1577	1429	1154
	208V	1629	1609	1584	1545	1478	1393	1214	1058

EF12		SP IN. WG.							
SPEED	Volts	0.3	0.4	0.5	0.6	0.7	0.8	0.9	1.0
LOW	230V	1103	1092	1086	1060	1024	973	906	803
	208V	903	893	877	858	830	781	728	642
MED	230V	1498	1473	1451	1409	1352	1277	1173	1044
	208V	1246	1239	1222	1202	1160	1098	1014	906
HIGH	230V	1860	1815	1760	1685	1596	1491	1352	1178
	208V	1602	1584	1553	1501	1432	1347	1241	1096

EF20		SP IN. WG.							
SPEED	Volts	0.3	0.4	0.5	0.6	0.7	0.8	0.9	1.0
LOW	230V	1673	1670	1669	1643	1587	1461	1298	1081
	208V	1320	1306	1289	1237	1147	1006	810	576
MED	230V	2060	2030	1980	1912	1835	1723	1594	1444
	208V	1676	1656	1613	1531	1381	1201	986	683
HIGH	230V	2554	2459	2352	2242	2116	1966	1809	1606
	208V	2420	2334	2244	2137	2021	1875	1732	1558

FILTER STATIC PRESSURE DROP										
MODEL	NOMINAL FILTER SIZE	CFM								
		600	800	1000	1200	1400	1600	1800	2000	
EF08	14 X 20	0.05	0.09	0.13	0.19	---	---	---	---	---
EF12	18 X 20	----	----	0.09	0.12	0.17	0.22	---	---	---
EF16	20 X 20	----	----	---	---	0.12	0.15	0.19	---	---
EF20	25 X 20	----	----	---	---	0.09	0.11	0.14	0.18	---



Sequence Of Operation			
Mode	Thermostat to Control Board 24 volt	Control State	Control Function
<b>Electric Heat Only</b>			
Constant Blower (Fan Switch ON)	G	On	Fan On.
		Off	Fan Off.
Thermostat calls for Heat	G & W1 & W2	On	Fan On, 1st Stage Of Heat On, then 2nd Stage Of Heat On.
		Off	2nd then 1st Stage Of Heat Off. 6 sec delay, then Fan Off.
<b>Cooling Only Unit With Electric Heat</b>			
Constant Blower (Fan Switch ON)	G	On	Fan On.
		Off	Fan Off.
Cooling Only Unit (Thermostat calls for Cooling)	Y & G	On	Compressor On, Fan On.
		Off	Compressor Off, 60 Second Delay - Then Fan Off.
Cooling Only Unit (Thermostat calls for Heat)	G & W1 & W2	On	Fan On, 1st Stage Of Heat On, then 2nd Stage Of Heat On.
		Off	2nd then 1st Stage Of Heat Off. 6 sec delay, then Fan Off.
<b>Heat Pump With Electric Heat</b>			
Heat Pump (Thermostat calls for Cooling)	Y & G & O	On	Compressor On, Reversing Valve Energized, Fan On.
		Off	Compressor Off, 60 Second Delay And Then Fan Off.
Heat Pump (Thermostat calls for Heat)	Y & G	On	Compressor On, Fan On
Heat Pump cannot maintain proper temp.	Y & G & W1 & W2	On	1st Stage Of Heat On, then 2nd Stage Of Heat On
		Off	2nd then 1st Stage Of Heat Off
Heat Pump (Goes into Defrost Mode)	Y & G & O & W1 & W2	On	Reversing valve switches unit to cooling, 1st Stage Of Heat On, then 2nd Stage Of Heat On
		Off	Reversing valve switches back to heating, 2nd then 1st Stage Of Heat Off
Heat Pump (Room temp. satisfied)	Y & G	Off	Compressor Off, 60 Second Delay And Then Fan Off.
Heat Pump (Emergency Heat)	G & W1 & W2	On	Fan On, 1st Stage Of Heat On, then 2nd Stage Of Heat On.
		Off	2nd then 1st Stage Of Heat Off. 6 sec delay, then Fan Off.

NOTE: Electric Heat Elements are controlled by relays with a delay sequence from the logic board to provide sequencing between elements.

## Limit Operation

The temperature limit responds to over-temperature conditions in the air duct. If the temperature limit trips, the electric heater relays will be de-energized and the fan relay will be energized. Once the limit resets, the control will resume normal operation. If the limit trips four times during a single call for heat, the control will go into a 1 hour soft lockout. During the soft lockout, the fan relay will respond to thermostat inputs but the heater relays are disabled. If the control detects a limit trip during the soft lockout, the control will go into a hard lockout. Once in a hard lockout, the fan relay is locked on and the heater relays are disabled. Turning the power to the unit off and then on will clear this state.

POWER SUPPLY: 208/230-1-60 USE COPPER CONDUCTORS ONLY.  
 KEY: ——— HIGH VOLT; - - - - - LOW VOLT.

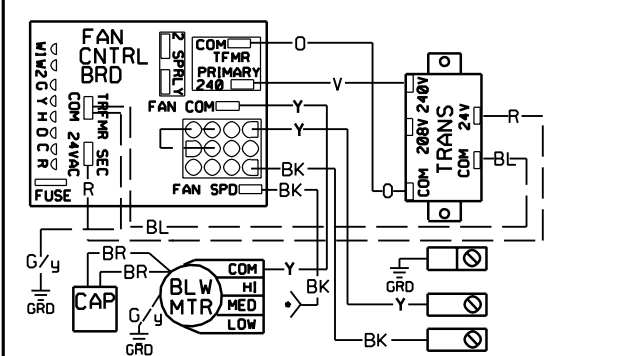

BASE UNIT WITH NO-HEAT KIT AMF001NH INSTALLED  
 \*SEE INSTALLATION MANUAL FOR PROPER HEATING AND COOLING  
 FACTORY PRE-SET SPEED CONNECTIONS FOR YOUR UNIT.

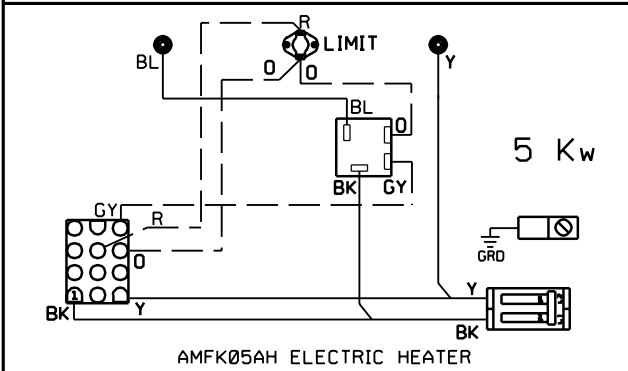

AMFK05AH ELECTRIC HEATER

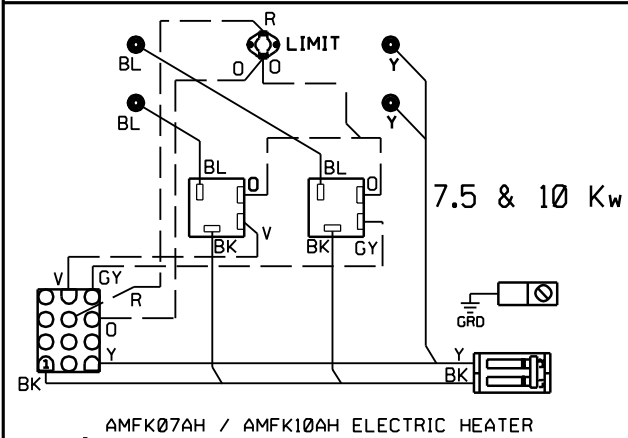

AMFK07AH / AMFK10AH ELECTRIC HEATER

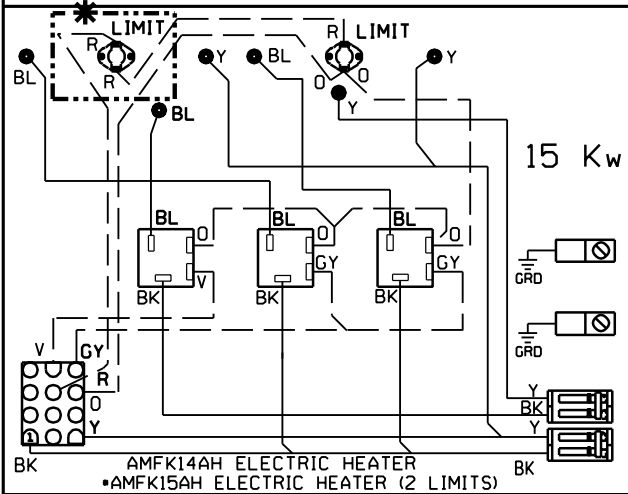

AMFK14AH ELECTRIC HEATER  
 \*AMFK15AH ELECTRIC HEATER (2 LIMITS)

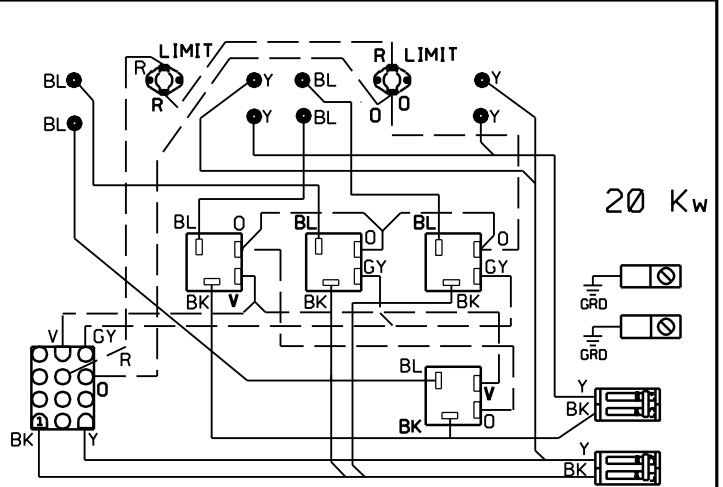

AMFK20AH ELECTRIC HEATER

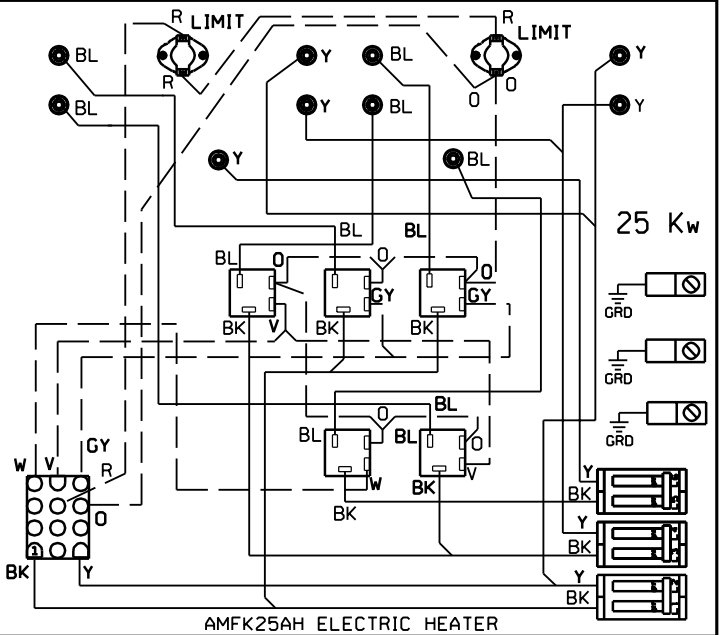

AMFK25AH ELECTRIC HEATER

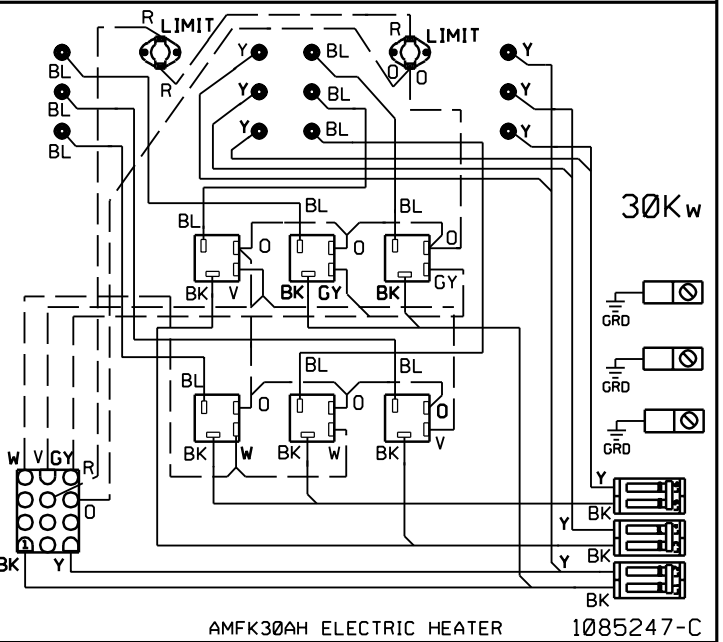

AMFK30AH ELECTRIC HEATER 1085247-C



Models EF08B1500A1 / A2, EF12F1900A1, EF16J2200A1, EF20N2600A1

Key No	Description	Part No.	EF--00A1			
			08	12	16	20
9	Control, Fan Timer	1085914	1	1	1	1
10	Transformer	1082611	1	1	1	1
11	Motor, Blower	1083044	1			
11		1083045	*	1	1	
11		1083046	*	*	*	1
12	Mount, Blower Motor	1002801	1	1	1	
12		609227	*	*	*	1
13	Wheel, Blower	600586	1			
13		600587	*	1		
13		96839	*	*	1	1
14	Capacitor, 10MFD, 370V	1094956	1	1	1	
14		15MFD, 370V	1094959	*	*	*
F	Wrapper	1084500	1			
F		1084501	*	1		
F		1084502	*	*	1	
F		1084503	*	*	*	1
H	Plate, Tubing	1082600	1	1	1	1
K	Grommet, Tubing Plate	1082987	1	1		
K		1082957	*	1	1	1
O	Panel, Rear Blower Deck	1082604	1			
O		1082844	*	1		
O		1082845	*	*	1	
O		1082846	*	*	*	1
P	Panel, Front Blower Deck	1082603	1			
P		1082841	*	1		
P		1082842	*	*	1	
P		1082843	*	*	*	1
Q	Panel, Side Blower Deck	1082622	2			
Q		1082847	*	2		
Q		1082848	*	*	2	
Q		1082849	*	*	*	2
R	Bracket, Control Fan	1082617	1	1	1	1
S	Bracket, Drain Pan	1082609	1			
S		1082927	*	1		
S		1082928	*	*	1	
S		1082929	*	*	*	1
T	Stop, Coil	1083349	2	2	2	2
U	Adapter, Filter	1084788	*	*	1	
V	Panel, Top	1082610	1			
V		1082835	*	1		
V		1082836	*	*	1	
V		1082837	*	*	*	1
W	Housing, Blower	1083343	1			
W		1082940	*	1		
W		1082941	*	*	1	1
X	Panel, Blower Cutoff	1082607	1			
X		1082616	*	1		
X		1082949	*	*	1	1
Y	Clamp, Capacitor	1095020	1	1	1	1
Z1	Rail, Blower R.H.	1082615	1	1	1	1
Z2	Rail, Blower L.H.	1082618	1	1	1	1

Key No	Description	Part No.	EF--00A1			
			08	12	16	20
AA	Door, Coil Access	1082606	1			
AA		1082930	*	1		
AA		1082931	*	*	1	
AA		1082932	*	*	*	1
AB	Panel, Fill-in	1084512	1			
AB		1084513	*	1		
AB		1084514	*	*	1	
AB		1084515	*	*	*	1
BB	Door, Blower Access	1082605	1			
BB		1085301**	1			
BB		1082838	*	1		
BB		1082839	*	*	1	
BB		1082840	*	*	*	1
CC	Door, Filter Access	1082608	1			
CC		1082832	*	1		
CC		1082833	*	*	1	
CC		1082834	*	*	*	1
DD	Plate, Heater Adapter	1084606	*	1	1	1
EE	Plate, Heater Filler	1084608	*	*	1	1
)	Manual, Installation	44201220100	1	1	1	1

\*\* EF08-- A1 Models with AMFK14 Electric Heat and all EF08--A2 models