

Edison



Edison

Product Catalog

Circuit Protection Products

COOPER Circuit Protection

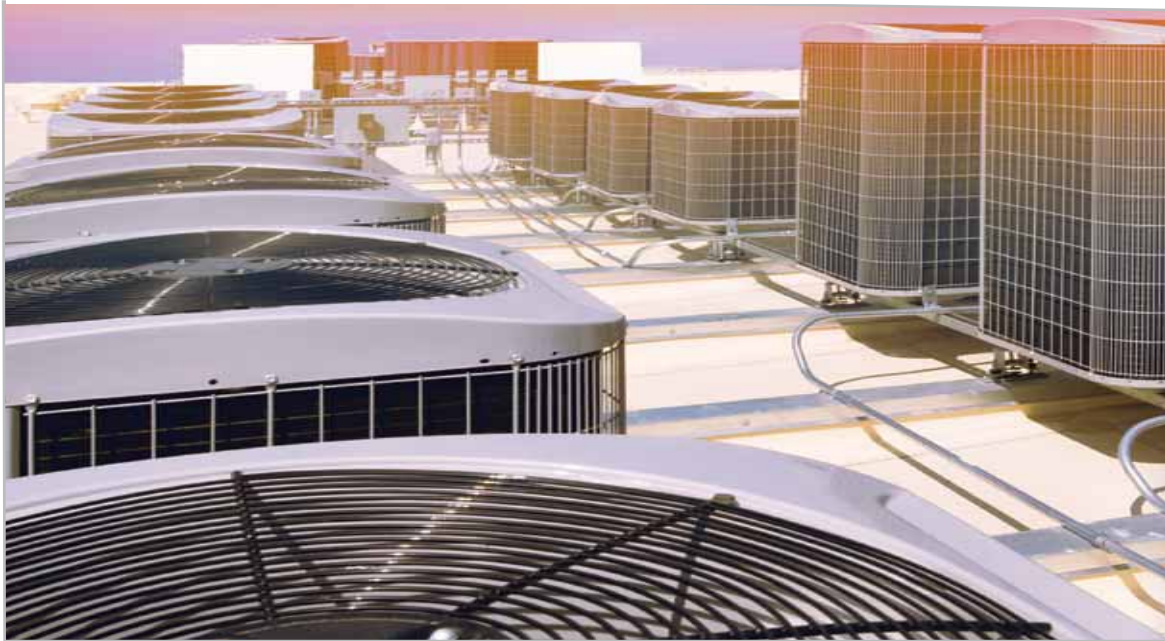

Index by Domestic Catalog Numbers Listed Numeric-Alpha

Catalog Number	Page	Catalog Number	Page	Catalog Number	Page	Catalog Number	Page
12ABCNA(Amp)	115	8.25BKNHK(Amp)E	108	GMC	42	No. 2661	152
12CAV	115	8000 Series Fuseblocks	150	GMD	42	No. 2661-R	152
12SDLSJ(amp)	118	A3354705	115	H Fuseblocks	123	No. 2662	152
12SFLSJ(Amp)	118	A3354745	121	HCLR	29	No. 2662-R	152
12SKLSJ(Amp)	118	ABC	43	HCTR	29	No. 2664	152
15.5ABFNA(Amp)	115	ACK	54	HEB	146	No. 2664-R	152
15.5CAV, CAVH	115	ACL	54	HET	146	No. 616	152
17.5ABGNA(Amp)	115	AGC	43	HEX	146	No. 626	152
17.5CAV	115	ALS	54	HEY	146	No. 626-R	152
17.5SDLSJ(Amp)	118	ANL	55	HKP Series	149	No. 642-R	152
17.5SDMSJ(Amp)	118	ANN	56	HPF	149	No. 663	152
17.5SFMSJ(amp)	118	ATC	46	HVAC Disconnects	151	No. 663-R	152
17.5SFMSJ(Amp)	118	ATM	46	In-Line Fuseholders	148	NZ01, NZ02	89
24ABGNA(Amp)	115	BH Modular Blocks	135	J Fuseblocks	129	P	40
24CAV	115	Box Cover Units	136	JDL	18	PB1 & PB3 Series	141
24SFMSJ(Amp)	118	CC Fuseblocks	133	JFL	20	PB4, PB5 & PB7 Series	143
25SFMSJ(Amp)	118	CCLB	52	JHL	59	PONC	92
2.75VFRHA(Amp)R	101	CCLW	52	KON	35, 92	R Fuseblocks	123
2.75VKRHA(Amp)R	101	CDNC	92	KOS	35, 92	S	37
2.75VKRHK(Amp)R	101	CDSC	92	LCL	14	SA	38
27.6SDMSJ(Amp)	118	Clip Clamps	153	LCT	84	SAFELOC HRC	98
27.6SFMSJ(Amp)	118	CM(XX)CF	95	LCU	14	SAMI Series	145
2703	121	C(XX)BS	98	LENRK	6	SCLR	11
3.6ABWNA(Amp)	115	C(XX)F	98	LESRK	6	SEC	25
3.6ABCNA(Amp)	115	C(XX)FBS	98	LET	84	SFC-Fuse-CAB	153
3.6ABGNA(Amp)	115	D16, D27, D33, D125	89	LMMT	84	SFE	46
3.6ADLSJ(Amp)	118	DRA-1, DRA-2	134	LMT	84	SL	37
3.6ADOSJ(Amp)	118	E100S	79	MAI	88	T	39
3.6CAV	115	E100SF	79	MAX	46	TC	40
3.6WDLSJ(Amp)	118	E13S	60	M Fuseblocks	134	T Fuseblocks	130
3.6WDOSJ(Amp)	118	E15SF	61	MCL	31	TI500	88
3.6WFLSJ(Amp)	118	E25SFX	64	MDA	44	TI700	88
3.6WFOSJ(Amp)	118	E50S	68	MDL	44	TJN	22
3.6WKLSJ(Amp)	118	E50SF	68	MEN	33	TJS	22
36CAV	115	E60C	71	MEQ	33	TL	39
36SDQSJ(Amp)	118	E60SF	73	MID	33	UCL 25XX to 75XX	47
36SFQSJ(Amp)	118	E70SF	75	MKE	45	UCLA	47
3835 Series	150	EBS	31	MOL	31	W	38
38CAV, CAVH	115	ECNR	1	MV055 Series	104		
4164	55	ECSR	1	MV155 Series	111		
5.5ABWNA(Amp)	115	EDCC	27	NCLR	11		
5.5AMWNA(Amp)	115	EPDB Series	138	NH	90		
5.5CAV, CAVH	115	ERFL	45	No. 213	152		
5.5VFNHA(Amp)R	101	ERFS	45	No. 213-R	152		
5.5VKNHA(Amp)R	101	ET	83	No. 216	152		
5.5VKNHK(Amp)R	101	FE	83	No. 216-R	152		
7.2ABWNA(Amp)	115	FEE	83	No. 226	152		
7.2ABCNA(Amp)	115	FM	83	No. 226-R	152		
7.2CAV	115	FMM	83	No. 242-R	152		
7.2SDLSJ(Amp)	118	FP Series (Fusepullers)	153	No. 2621	152		
7.2SFMSJ(Amp)	118	G Fuseblocks	132	No. 2621-R	152		
7.2WKMSJ(Amp)	118	GBB	43	No. 263	152		
8.25FFNHA(Amp)E	108	GDA	41	No. 263-R	152		
8.25FFNHK(Amp)E	108	GDB	41	No. 2641	152		
8.25BFNHA(Amp)E	108	GDC	41	No. 2641-R	152		
8.25BFNHK(Amp)E	108	GMA	42	No. 2642	152		

Edison circuit protection solutions comply with major industrial standards and agency requirements such as: BS, IEC, DIN, UL, NEMA, SAE, CSA, CE, C-UL, etc. and are manufactured at facilities that are ISO 9000 certified. This catalog is intended to present product data and provide technical information that will help the end user with design application. We reserve the right, without notice, to change design or construction of any products and to discontinue or limit distribution of any products. We also reserve the right to change or update, without notice, any technical information contained in this catalog. Once a product has been selected, it should be tested by the user in all possible applications. Further, We take no responsibility for errors or omissions contained in this catalog, or for misapplication of any Edison product. Extensive product information is available in the Edison product data sheets available online at www.edisonfuse.com.

General Catalog Contents

Page

UL Fuses: Current Limiting

Class RK5	Dual-Element, Time-Delay - ECNR/ECSR	1
Class RK1	Dual-Element, Time-Delay - LENRK/LESRK	6
Class RK	Fast-Acting - NCLR/SCLR	11
Class L	Time-Delay - LCL	14
	Fast-Acting - LCU	14
Class J	Dual-Element, Time-Delay - JDL	18
	Fast-Acting - JFL	20
Class T	Extremely Fast-Acting - TJN/TJS	22
Class G	SEC	25
Class CC	Time-Delay - EDCC	27
	Time-Delay - HCTR	29
	Fast-Acting - HCLR	29

UL Fuses: General Purpose

Midget Fuses ($\frac{13}{32}$ " x 1 $\frac{1}{2}$ ")	Fast-Acting - MCL	31
	Fast-Acting - MOL	31
	$\frac{13}{32}$ " x 1 $\frac{1}{8}$ ", Fast-Acting - EBS	31
	Time-Delay - MEN	33
	Time-Delay - MEQ	33
	Pin Indicating, Time-Delay - MID	33
Class H and KS "One-Time"	Fast-Acting - KON/KOS	35
Plug Fuses	Rejection Base, Dual-Element, Time-Delay - S	37
	Rejection Base, Time-Delay - SL	37
	Edison Base, Fast-Acting - W	38
S and SL Rejection Base Fuse Adapter	SA	38
Plug Fuses	Edison Base, Dual-Element, Time-Delay - T	39
	Edison Base, Time-Delay - TL	39
	Edison Base, Dual-Element, Time-Delay - TC, P	40
5 x 20mm Fuses	Ceramic, Fast-Acting - GDA	41
	Glass, Fast-Acting - GDB	41
	Glass, Time-Delay - GDC	41
	Glass, Fast-Acting - GMA	42
	Glass, Medium Time-Delay - GMC	42
	Glass, Time-Delay - GMD	42
$\frac{1}{4}$ " x 1 $\frac{1}{4}$ " Fuses	Glass, Fast-Acting - ABC	43
	Glass, Fast-Acting - AGC	43
	Ceramic, Very Fast-Acting - GBB	43
	Ceramic, Time-Delay - MDA	44
	Glass, Time-Delay - MDL	44
Electronic & Electrical Fuse Displays & Assortments	ERFL/ERFS, MKE	45
Automotive Fuses	Glass, Fast-Acting - SFE	46
	Blade, Fast-Acting - ATM, ATC, MAX	46

Special Purpose Fuses

Cable Limiters	UCL/UCLA	47
Capacitor Fuse, Non-Time-Delay	CCLB/CCLW	52
Lift Truck Fuses	ACK/ACL/ALS	54
Limiters	ANL Non-Time-Delay	55
	ANN Very Fast-Acting	56
High Speed Fuses,		57
	JHL	59
	130V - E13S	60
	150V - E15SF/E15S	61
	250V - E25SFX/E25S	64
	500V - E50SF/E50S	68
	600V - E60C	71
	600V - E60SF/E60S	73
	700V - E70SF/E70S	75
	1000V - E100SF/E100S	79
	British Style	82

General Catalog Contents (Con't.)

Page

Special Purpose Fuses (Con't)

Trip Indicators	.88
Microswitch Adapter - MAI	.88
Type "D" Bottle Fuses	.89
Neozed Fuses	.89
NH Fuses	.90
Canadian Fuses & Accessories	
Standard Code Fuses 250V & 600V	KOS/KON/PONC .92
	CDSC/CDNC .92
Fuse Holders	CAMaster HRC Fuse Holder .95
	SAFEloc HRCI-CB Fuse Holder .98

Medium Voltage Fuses

R-Rated Fuses	2.75 to 5.5kV .101
E-Rated Fuses	5.5kV MV055 .104
	8.25kV .108
	15.5kV MV155 .111
Potential Transformer Fuses	3.6 to 38kV AB, AM and CAV Series .115
High Voltage DIN Distribution Fuses	3.6 to 36kV .117

Fuse Blocks, Holders & Misc.

Class H (K) and R Fuse Blocks	H250, H600, R250 and R600 Series .123
Class J Fuse Blocks	J600 Series .129
Class T Fuse Blocks	T300 and T600 Series .130
Class G Fuse Blocks	BG Series .132
Class CC Fuse Blocks	BC Series .133
Midget Fuse Blocks	BM Series .134
DIN and American Rail Adapters	DRA-1 and DRA-2 .134
Modular Fuse blocks	BH Series .135
Edison Base Plug Fuse Holders	Box Cover Units .136
Power Blocks	Enclosed Power Distribution Blocks .138
	High SCCR Terminal Blocks .141
	Power Distribution Blocks .143
SAMI Fuse Covers	For Class J, RK, K5, H and Midget Fuses .145
In-line Fuse Holders	Class CC and Midget Fuses - HEB/HET/HEY/HEX .146
Panel Mount Fuse Holders	¼" x 1 ¼" Fuses - HKP, HKP-HH/HKP-W .149
	¹³ / ₃₂ " x 1 ½" Fuses - HPF .149
Fuse Blocks	¹³ / ₃₂ " x 1 ½" Fuses - 3835 Series .150
	¼" x 1 ¼" Fuses - S-8000 Series .150
HVAC Disconnects	B22 Series .151
Fuse Reducers	Class H, J, K, & R .152
Spare Fuse Cabinet	SFC-FUSE-CAB .153
Fuse Clip Clamp	.153
Fuse Pullers	FP Series .153

Elements of a Practical Fuse Specification	154
---	------------

Fuse Terminology	155
-------------------------	------------

Cross Reference Guide	156
------------------------------	------------

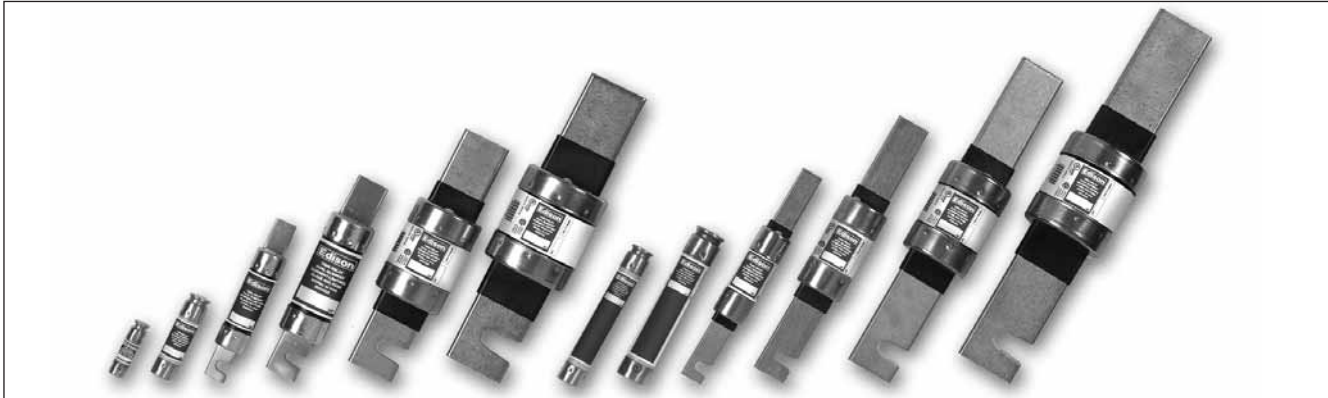

Catalog Number ECNR (1 - 600A) 250Vac or Less
Catalog Number ECSR (1 - 600A) 600Vac or Less

Amp Ratings					
ECNR					
1	8	25	70	150	400
2	9	30	75	175	450
3	10	35	80	200	500
4	12	40	90	225	600
5	15	45	100	250	—
6	17.5	50	110	300	—
7	20	60	125	350	—
ECSR					
1	8	25	70	150	400
2	9	30	75	175	450
3	10	35	80	200	500
4	12	40	90	225	600
5	15	45	100	250	—
6	17.5	50	110	300	—
7	20	60	125	350	—

ECNR/ECSR Specifications

Dual-Element Time-Delay

Voltage Rating: ECNR - 250Vac
ECNR - (1-60A, 110-200A) 125Vdc;
(225-600A) 250Vdc
ECSR - 600Vac
ECSR - (1-30A, 70-600A) 300Vdc
(35-60A) 250Vdc

Amp Rating: 1 - 600A

Interrupting Rating: 200kA RMS Symmetrical Amps

Current Limiting: RK5 Fuse

Agency Approvals:
UL Listed for US and Canada, Class RK5, Guide JDDZ, File E162363

Interrupting Rating: ECNR/ECSR 20kA DC

Benefits:

- True dual-element construction allows sizing of 125% FLA for motor backup protection.
- Superior overload and cycling capabilities.
- Current limiting provides component short-circuit protection.

Applications:

- Recommended for AC power distribution system mains, feeders, and branch circuits.
- Protection of motors and motor branch circuits.
- Protection of transformers and other inductive loads.
- All general-purpose applications including lighting, heating and other non-inductive loads.

Recommended Fuse Blocks:

Refer to pages 126 and 128 in this catalog.

Recommended Upgrade:

Class RK1 (LENRK/LESRK) for greater degree of short-circuit protection.

CROSS REFERENCE			
VOLTS	EDISON	GOULD	LITTELFUSE
250	ECNR	TR	FLNR
600	ECSR	TRS	FLSR

ECNR/ECSR Dual Element Fuses

These fuses are recommended for AC power distribution system mains, feeders and branch circuits having inductive loads (motors, transformers) or non-inductive loads (lighting, heating) where the available short-circuit current does not exceed 200,000 RMS symmetrical amps. These “dual-element, time-delay” fuses have minimum industry standard time-delay of 10 seconds at 5 times the fuse rating (8 sec. minimum for 250V, 30A and less). The time-delay

characteristics of these fuses typically allows them to be sized closer to the running ampacity of inductive loads to reduce cost and provide improved overcurrent protection. These fuses will override normal equipment current surges to reduce unnecessary fuse openings. They are the most popular fuses used in the industry and the most economical for most applications, especially motors and transformers. They have moderate current limitation.

Class R fuses will fit Class H, K and R fuse clips. Class R fuse clips will only accept Class R fuses. Fuses rated 600Vac or less may be applied at any lower voltage. Contact Edison Custom Satisfaction for special products or applications.

Dimensions

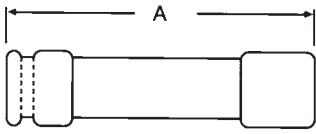

Ferrule Design—0 through 60 Amps

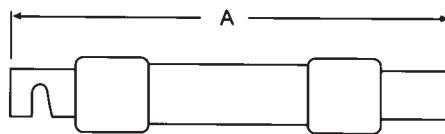

Knife Blade—70 through 600 Amps



Catalog Number	Amps	Overall Length - in	Max Diameter - in
		A	B
ECNR	0-30	2	0.56
	35-60	3	0.81
	70-100	5.88	1.06
	110-200	7.13	1.56
	225-400	8.63	2.38
	450-600	10.38	2.88
ECSR	0-30	5	0.81
	35-60	5.5	1.06
	65-100	7.88	1.11
	110-200	9.63	1.61
	225-400	11.63	2.34
	450-600	13.38	2.88

Average Melt Time-Current Curves
Cat No. ECNR (Amp)

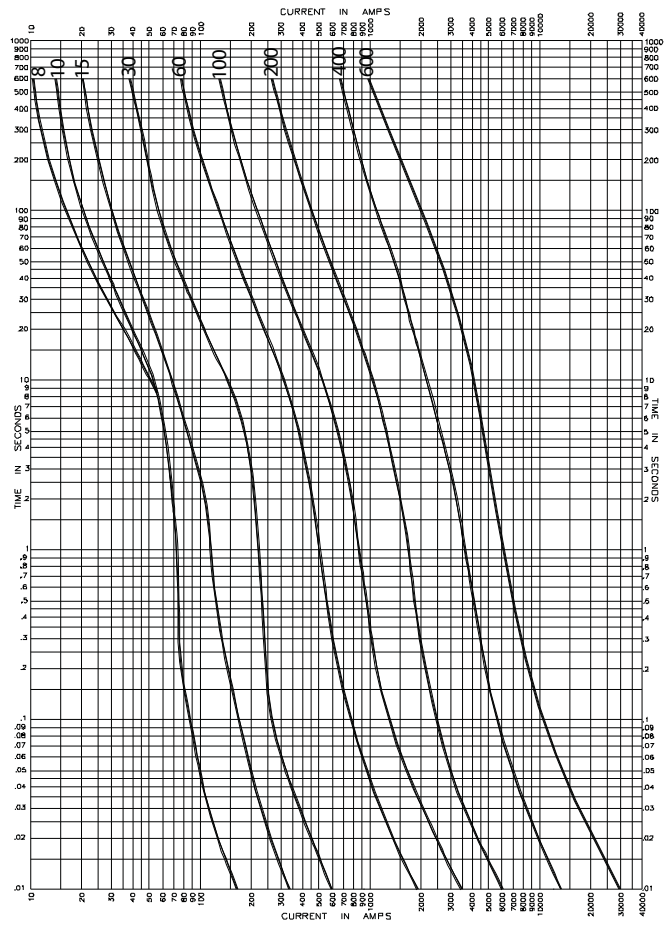
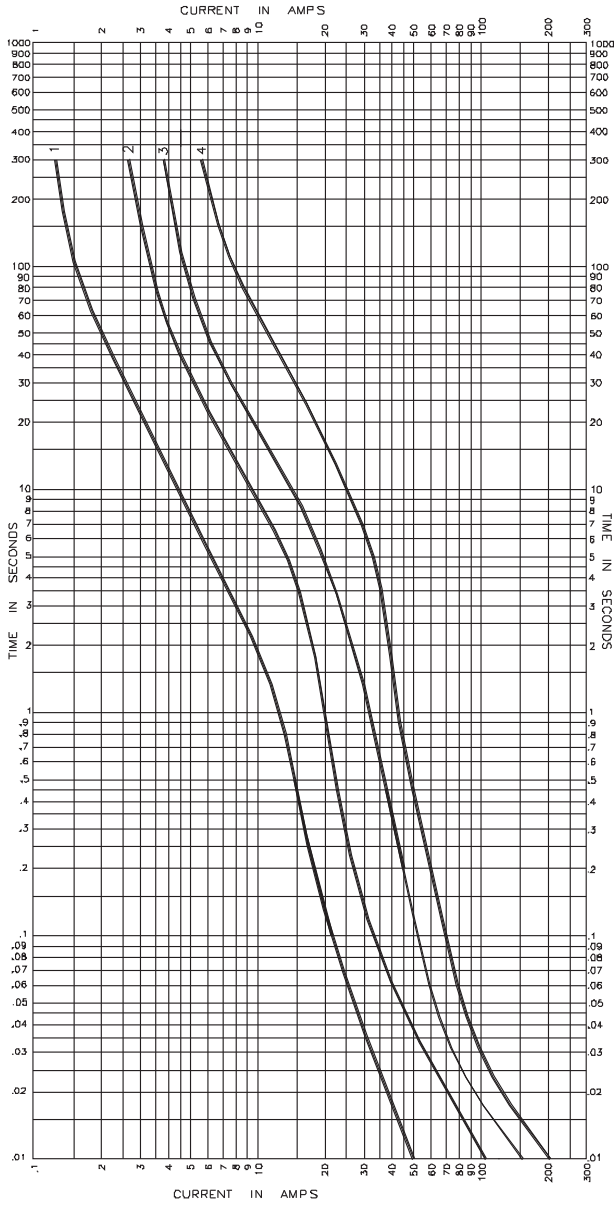

Average Melt Time-Current Curves
Cat No. ECSR (Amp)

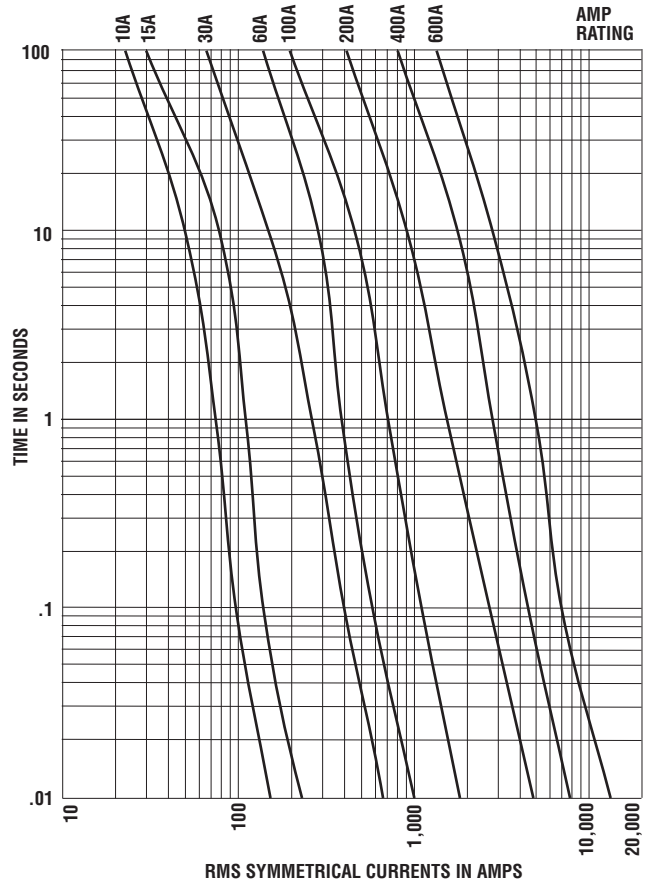
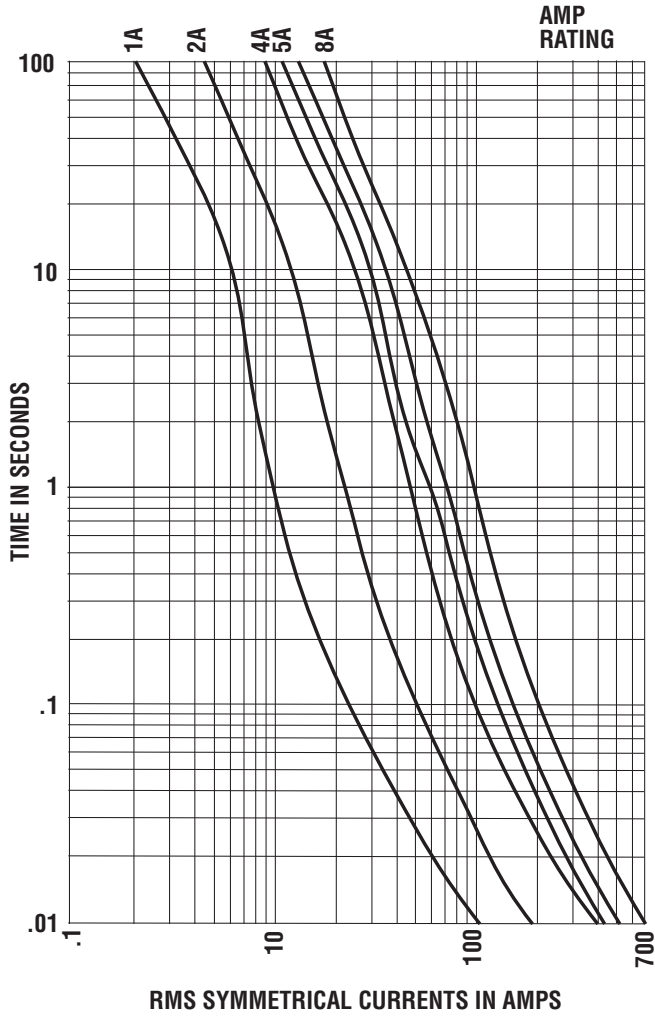

Peak Let-Through Current Curves

ECNR

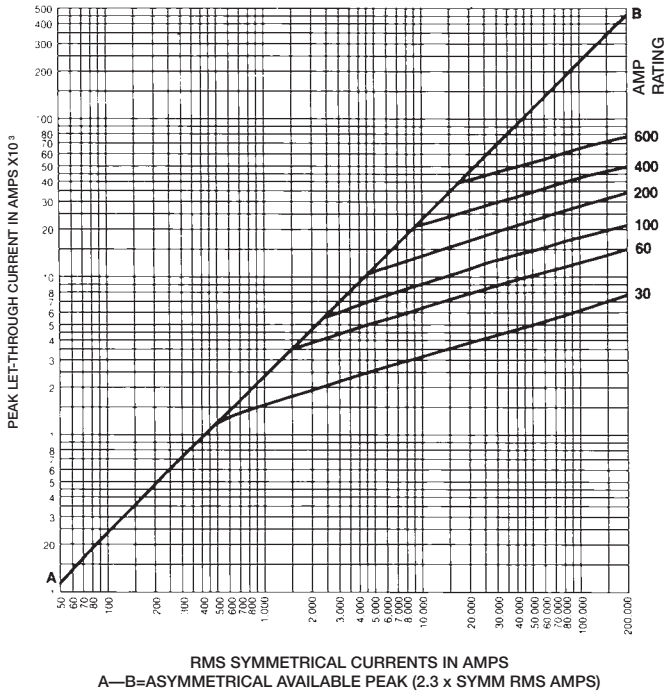

ECSR

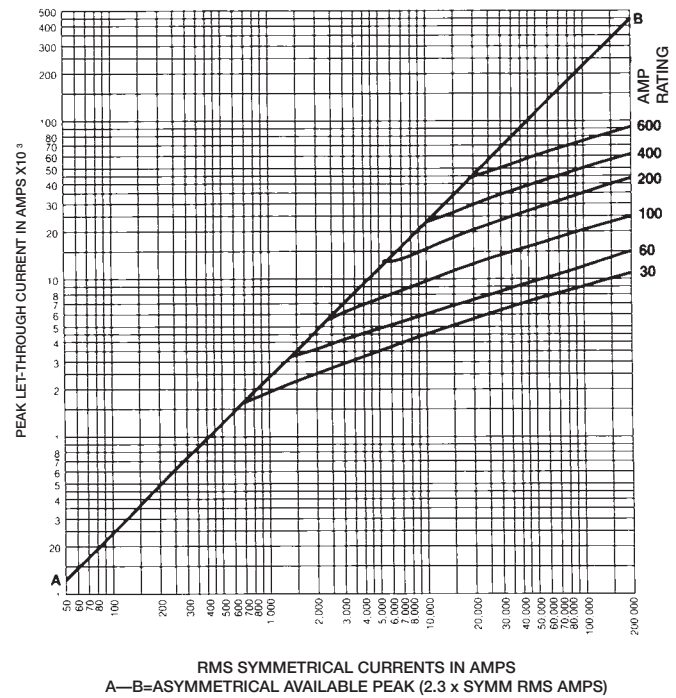

Current Limitation Tables

ECNR*

Available Fault Current RMS Amps	Apparent Effective Let-Through Amps					
	Fuse Amp Ratings					
	30A	60A	100A	200A	400A	600A
5,000	1,050	2,070	2,820	4,300	5,000	5,000
10,000	1,310	2,570	3,630	5,400	8,700	10,000
15,000	1,490	2,920	4,140	6,200	9,900	15,000
20,000	1,630	3,200	4,500	6,800	10,700	16,100
25,000	1,720	3,420	4,800	7,200	11,400	17,200
30,000	1,840	3,630	5,100	7,700	12,100	18,300
35,000	1,920	3,810	5,400	8,100	12,600	19,200
40,000	2,000	3,980	5,600	8,500	13,100	19,900
50,000	2,140	4,200	6,000	9,100	14,000	21,400
60,000	2,260	4,500	6,400	9,600	14,900	22,600
80,000	2,450	4,900	7,000	10,600	16,000	24,600
100,000	2,620	5,200	7,500	11,400	17,100	26,200
150,000	2,920	5,800	8,300	13,000	19,200	29,200
200,000	3,140	6,200	8,900	14,300	20,800	31,700

ECSR*

Available Fault Current RMS Amps	Apparent Effective Let-Through Amps					
	Fuse Amp Ratings					
	30A	60A	100A	200A	400A	600A
5,000	1,290	2,070	2,980	5,000	5,000	5,000
10,000	1,640	2,590	3,810	6,500	8,800	10,000
15,000	1,890	2,940	4,400	7,500	10,200	15,000
20,000	2,110	3,250	4,800	8,300	11,400	18,200
25,000	2,260	3,470	5,200	8,900	12,400	19,600
30,000	2,420	3,660	5,500	9,600	13,200	21,100
35,000	2,570	3,850	5,800	10,100	14,100	22,400
40,000	2,670	4,030	6,000	10,500	14,700	23,400
50,000	2,890	4,300	6,500	11,400	16,000	25,300
60,000	3,060	4,500	6,900	12,100	17,200	27,000
80,000	3,360	4,900	7,600	13,400	19,100	29,500
100,000	3,630	5,200	8,200	14,400	20,700	31,700
150,000	4,100	5,800	9,300	16,500	23,900	36,300
200,000	4,400	6,100	10,400	18,300	26,700	39,500

*"Apparent Let-Through Amps" values are read from "Peak Let-Through Current Curves" and the peak current value divided by 2.3 Asymmetry Factor.

LENRK/LESRK Class RK1 Dual-Element Time-Delay Fuses



Catalog Number LENRK (0.2 - 600A) 250Vac or Less
Catalog Number LESRK (0.25 - 600A) 600Vac or Less

Amp Ratings				
LENRK				
0.2	2	6.25	40	175
0.3	2.25	8	45	200
0.4	2.5	9	50	225
0.5	3	10	60	250
0.6	3.2	12	70	300
0.8	3.5	15	80	350
1	4	17.5	90	400
1.12	4.5	20	100	450
1.4	5	25	110	500
1.6	5.6	30	125	600
1.8	6	35	150	
LESRK				
0.25	2.25	6.25	35	150
0.5	2.5	7	40	175
0.6	2.8	8	45	200
1	3	9	50	225
1.12	3.2	10	60	250
1.25	3.5	12	70	300
1.4	4	15	80	350
1.5	4.5	17.5	90	400
1.6	5	20	100	450
1.8	5.6	25	110	500
2	6	30	125	600

LENRK/LESRK Specifications

Dual-Element Time-Delay

Voltage Rating: LENRK - 250Vac, LESRK - 600Vac

Amp Rating: 0.2 - 600A

Interrupting Rating: 200kA RMS Symmetrical Amps

Current Limiting: RK1 Fuse

Agency Approvals:

UL Listed, Class RK1, Guide JDDZ, File E162363
 CSA Certified, HRCI-R per C22.2, No. 248.12

Self-Certified DC Ratings:

Voltage Rating: LENRK (0-60A) 125Vdc; (70-600A) 250Vdc
 LESRK (0.25-600A) 300Vdc

Interrupting Rating: LENRK/LESRK 20kA DC

Benefits:

- True dual-element spring - trigger construction allows sizing of 125% FLA for motor backup protection.
- Superior overload and cycling capabilities.
- Extremely current limiting provides superior short-circuit component protection.

Applications:

- Recommended for AC power distribution system mains, feeders, and branch circuits.
- Protection of motors and motor branch circuits.
- Type 2 "No Damage" protection for IEC components.
- All general-purpose applications including lighting, heating and other non-inductive loads.

Recommended Fuse Blocks:

Refer to pages 124 and 126 in this catalog.

Recommended Upgrade:

None.

CROSS REFERENCE			
VOLTS	EDISON	GOULD	LITTELFUSE
250	LENRK	A2DR	LLNRK
600	LESRK	A6DR*	LLSRK

*Not dual element 110 - 600 Amp

LENRK/LESRK Class RK1 Dual-Element Time-Delay Fuses



LENRK/LESRK Dual-Element Fuses

The application recommended for these fuses is exactly the same as for the Edison ECNR/ECSR fuses except for the advantages of greater current limitation. The Edison LENRK/LESRK fuses have up to 40% more current limitation and up to 350% more Amps-Squared-Second (I^2t) limitation under fault conditions than Edison ECNR/ECSR fuses to reduce potential for damage. In addition, LENRK/LESRK fuses allow better selectivity for electrical power system designers and better short-circuit protection for breakers having inadequate interrupting ratings. ECNR/ECSR and LENRK/LESRK fuse lines are physically interchangeable (and electrically interchangeable per UL equipment listing conditions) and are recommended as a practical, economical way to upgrade systems for many situations.

True Dual-Element Construction

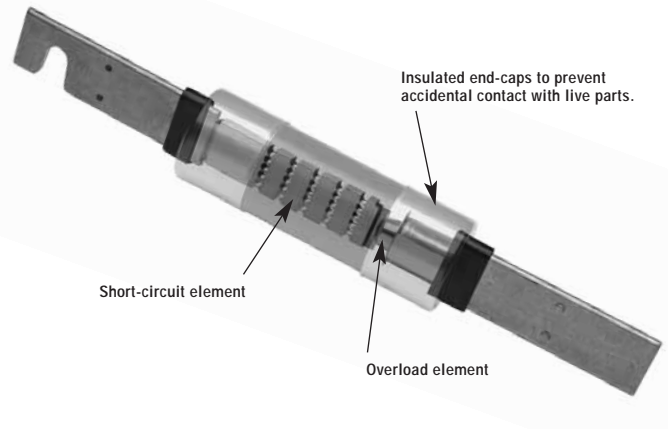

Class R fuses will fit Class H, K and R fuse clips. Class R fuse clips will only accept Class R fuses. Fuses rated 600Vac or less may be applied at any lower voltage. Contact Edison Custom Satisfaction for special products or applications.

Dimensions

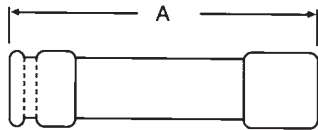

Ferrule Design—0 through 60 Amps

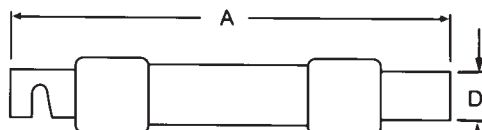

Knife Blade—70 through 600 Amps

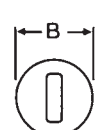

Catalog Number	Amps	Overall Length - in	Max Diameter - in
		A	B
LENRK	0-30	2	0.56
	35-60	3	0.81
	70-100	5.88	1.10
	110-200	7.13	1.61
	225-400	8.63	2.38
450-600	10.38	2.88	
LESRK	0-30	5	0.81
	35-60	5.5	1.06
	70-100	7.88	1.11
	110-200	9.63	1.61
	225-400	11.63	2.36
450-600	13.38	2.88	

UL/CSA Fuses
Current Limiting

UL/CSA Fuses
General Purpose

Special
Purpose Fuses

Canadian
Fuses & Holders

Medium
Voltage Fuses

Fuse Blocks,
Holders & Misc.

Application
Section

Average Melt Time-Current Curves

LESRK (Amp)

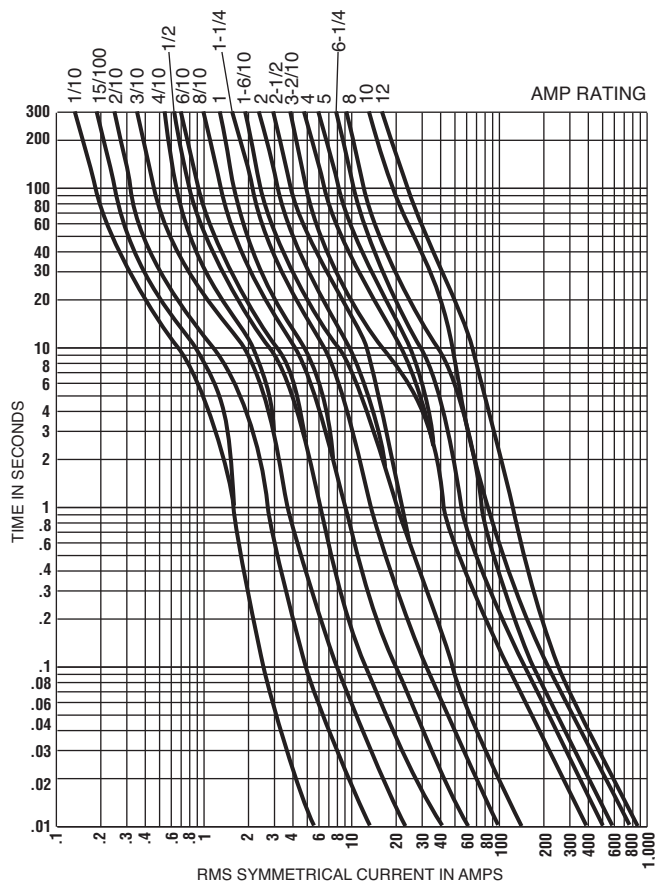

Average Melt Time-Current Curves

LENRK

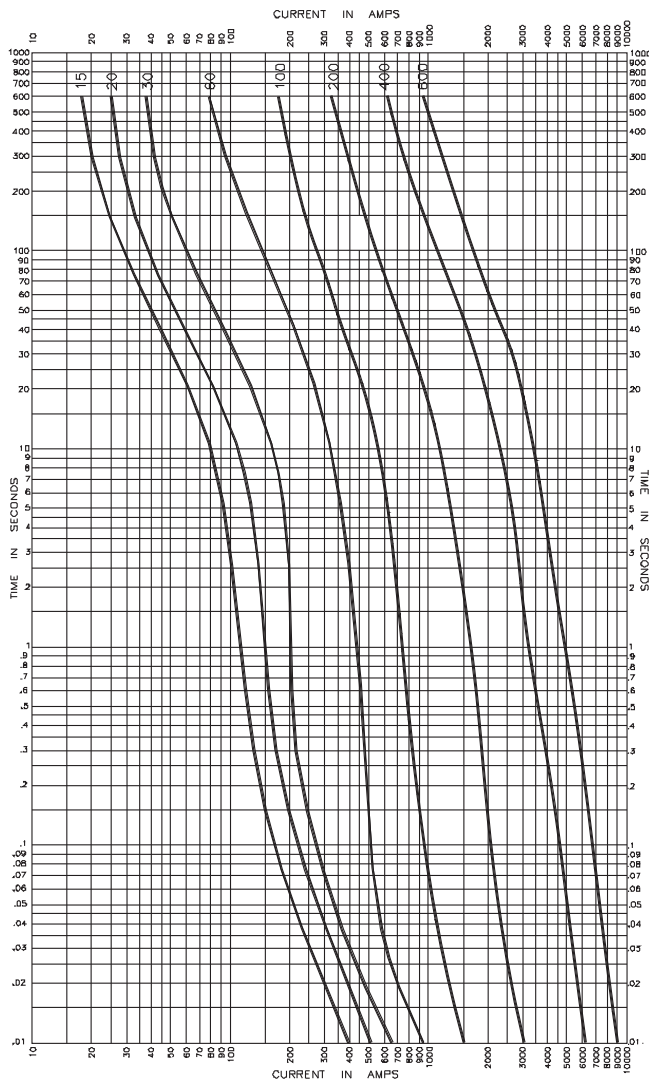

LESRK

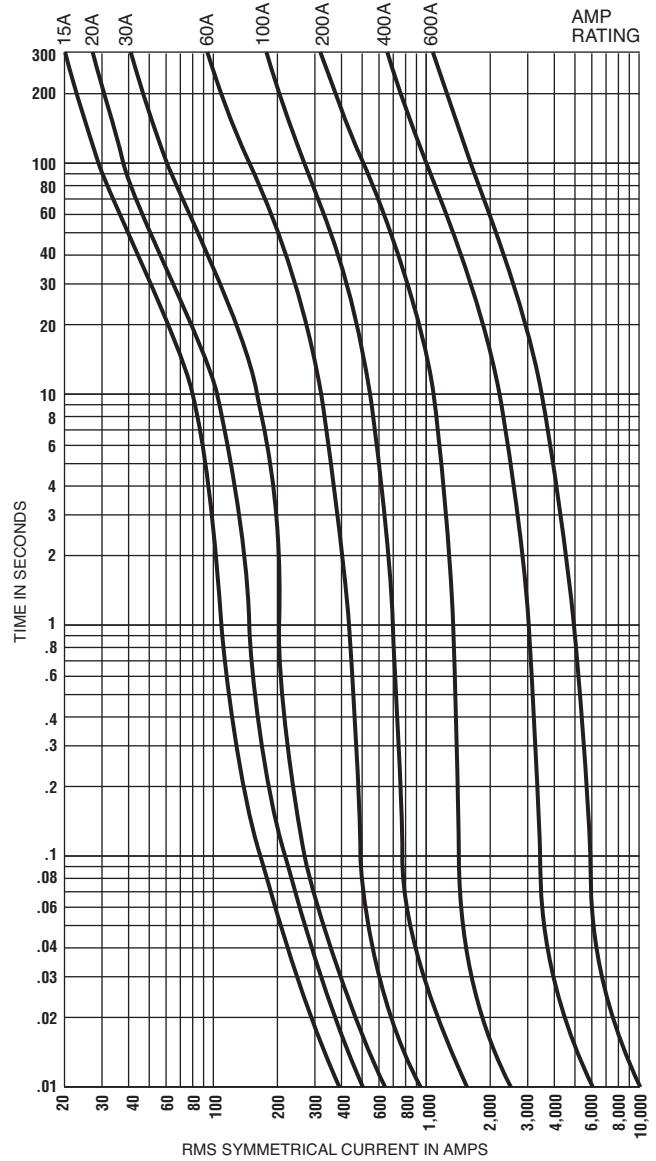

Peak Let-Through Current Curves*

LENRK

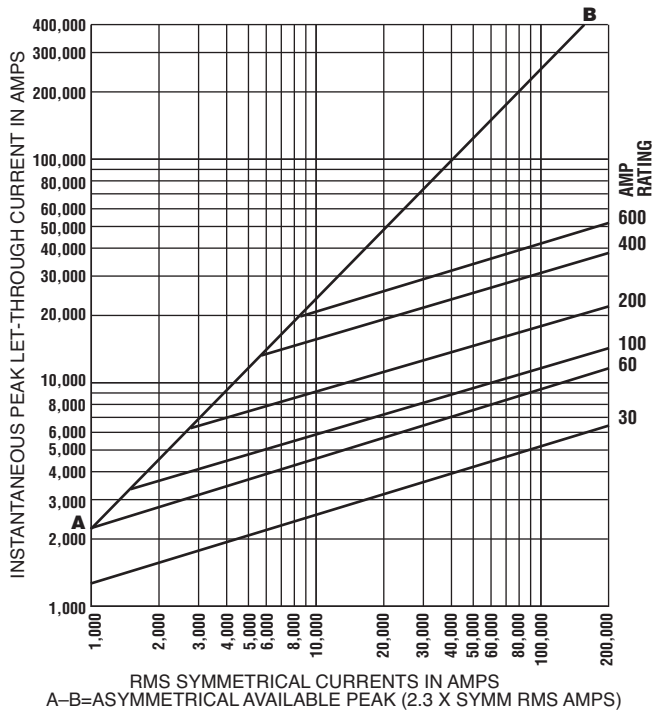

LESRK

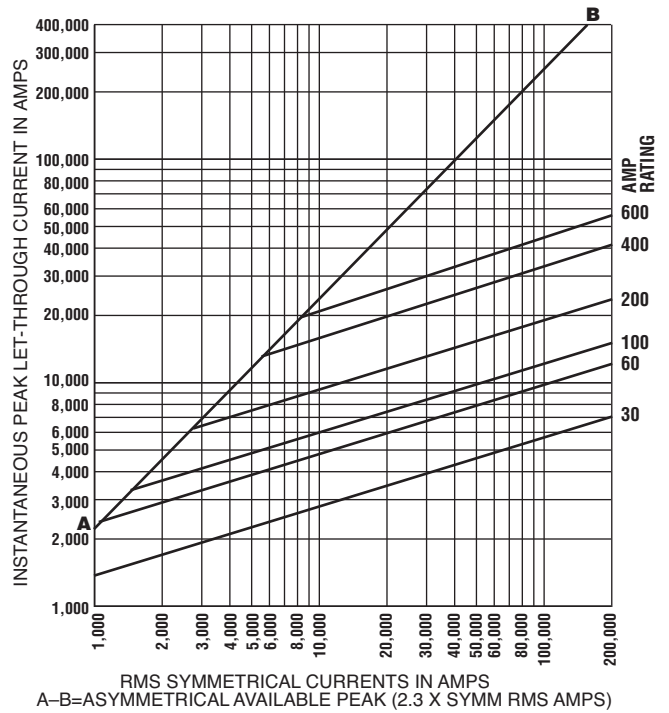

*Curves test data obtained at 15% short-circuit power factor when possible.

Current Limitation Tables**

LENRK RMS & Peak Let-Through Currents (kA)

Available Fault current RMS Amps	Apparent Effective Let-Through Amps (kA)											
	30		60		100		200		400		600	
	I _{RMS}	I _p	I _{RMS}	I _p	I _{RMS}	I _p	I _{RMS}	I _p	I _{RMS}	I _p	I _{RMS}	I _p
1,000	1	1	1	2	1	2	1	2	1	2	1	2
2,000	1	2	1	3	2	4	2	5	2	5	2	5
3,000	1	2	1	3	2	4	3	6	3	7	3	7
5,000	1	2	2	4	2	5	3	7	5	12	5	12
10,000	1	3	2	4	2	6	4	9	7	15	9	21
15,000	1	3	2	5	3	6	4	10	7	17	10	23
20,000	1	3	2	6	3	7	5	11	8	19	11	25
25,000	1	3	3	6	3	7	5	12	9	20	12	27
30,000	2	3	3	6	3	8	5	12	9	21	13	29
35,000	2	4	3	7	4	8	6	13	10	22	13	30
40,000	2	4	3	7	4	9	6	13	10	23	13	31
50,000	2	4	3	7	4	9	6	14	10	24	14	33
60,000	2	4	3	8	4	10	7	15	11	26	15	35
70,000	2	4	3	8	4	10	7	16	12	27	16	36
80,000	2	5	4	8	5	11	7	16	12	28	17	38
90,000	2	5	4	9	5	11	7	17	13	29	17	39
100,000	2	5	4	9	5	11	8	18	13	30	17	40
150,000	2	6	4	10	5	13	8	19	16	36	20	46
200,000	3	6	5	11	6	14	9	21	18	42	22	50

LESRK RMS & Peak Let-Through Currents (kA)

Available Fault current RMS Amps	Apparent Effective Let-Through Amps (kA)											
	30		60		100		200		400		600	
	I _{RMS}	I _p	I _{RMS}	I _p	I _{RMS}	I _p	I _{RMS}	I _p	I _{RMS}	I _p	I _{RMS}	I _p
1,000	1	1	1	2	1	2	1	2	1	2	1	2
2,000	1	2	1	3	2	4	2	4	2	4	2	4
3,000	1	2	1	3	2	4	3	6	3	7	3	7
5,000	1	2	2	4	2	5	3	7	5	12	5	12
10,000	1	3	2	5	3	6	4	9	7	16	9	21
15,000	1	3	2	5	3	7	5	11	8	18	10	24
20,000	1	3	3	6	3	7	5	12	8	19	11	26
25,000	2	4	3	6	3	8	5	12	9	21	12	28
30,000	2	4	3	6	4	8	6	13	10	22	13	30
35,000	2	4	3	7	4	9	6	14	10	23	13	31
40,000	2	4	3	7	4	9	6	14	10	24	14	32
50,000	2	5	3	8	4	10	7	15	11	26	15	35
60,000	2	5	3	8	4	10	7	16	12	28	16	37
70,000	2	5	4	8	5	11	7	17	13	29	17	39
80,000	2	5	4	9	5	11	8	18	13	30	17	40
90,000	2	5	4	9	5	12	8	18	13	31	18	42
100,000	2	6	4	9	5	12	8	19	14	32	19	44
150,000	3	6	5	11	6	14	9	21	16	36	22	50
200,000	3	7	5	12	7	15	10	23	17	40	23	54

**"Apparent Let-Through Amps" values are read from "Peak Let-Through Current Curves" and the peak current value divided by 2.3 Asymmetry Factor.

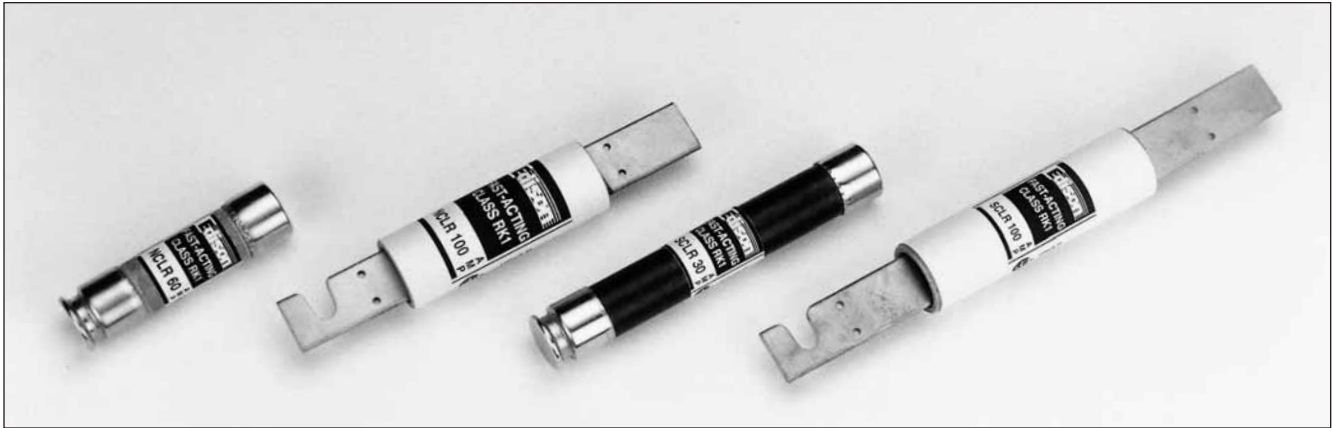

Catalog Number NCLR (1- 600A) 250Vac or Less
Catalog Number SCLR (1- 600A) 600Vac or Less

Amp Ratings					
NCLR					
1	10	35	80	175	400
3	12	40	90	200	450
4	15	45	100	225	500
5	20	50	110	250	600
6	25	60	125	300	—
8	30	70	150	350	—
SCLR					
1	8	30	70	150	350
2	10	35	80	175	400
3	12	40	90	200	450
4	15	45	100	225	500
5	20	50	110	250	600
6	25	60	125	300	—

NCLR/SCLR Specifications
Fast-Acting

Voltage Rating: NCLR - 250Vac, SCLR - 600Vac

Amp Rating: 1 - 600A

Interrupting Rating: 200kA RMS Symmetrical Amps

Current Limiting: RK1 Fuse

Agency Approvals:

UL Listed, Class RK1, Guide JDDZ, File E162363
CSA Certified per C22.2, No. 248.12

Self-Certified DC Ratings:

Voltage Rating: NCLR (1-600) 250Vdc
SCLR (1-600) 300Vdc

Interrupting Rating: NCLR/SCLR 10kA DC

Benefits:

- No intentional time-delay opens quickly on overload current.

Applications:

- Recommended for protection on non-inductive loads such as lighting and resistance heating circuits.
- Use to protect lower interrupting rating circuit breakers in series rated applications.

Recommended Fuse Blocks:

Refer to pages 124 and 126 in this catalog.

Recommended Upgrade:

LENRK/LESRK.

CROSS REFERENCE			
VOLTS	EDISON	GOULD	LITTELFUSE
250	NCLR	A2KR	KLNR
600	SCLR	A6KR*	KLSR*

* Larger body size on blade type.

Application:

Edison NCLR/SCLR Class RK1 fast-acting fuses are recommended for general power distribution system use for main, feeder and branch circuits having a high percentage of non-inductive loads such as heating and lighting. NCLR/SCLR fuses are suitable for circuit breaker protection.* When NCLR/SCLR fast-acting fuses are used for inductive loads, the fuses usually require oversizing to override normal transient current surges of motors and

transformers. Oversizing fuses usually increases fuse and equipment cost and reduces overcurrent protection. (For inductive loads, LENRK/LESRK fuses are recommended). NCLR/SCLR Class RK1 fast-acting fuses are physically interchangeable with other Class R fuses. They will replace Class K or Class H fuses in standard fuse clips.

*When used as recommended by a specific circuit breaker manufacturer for a specific application.

Average Time-Current Curves

Cat. No. NCLR (Amp) and SCLR (Amp)

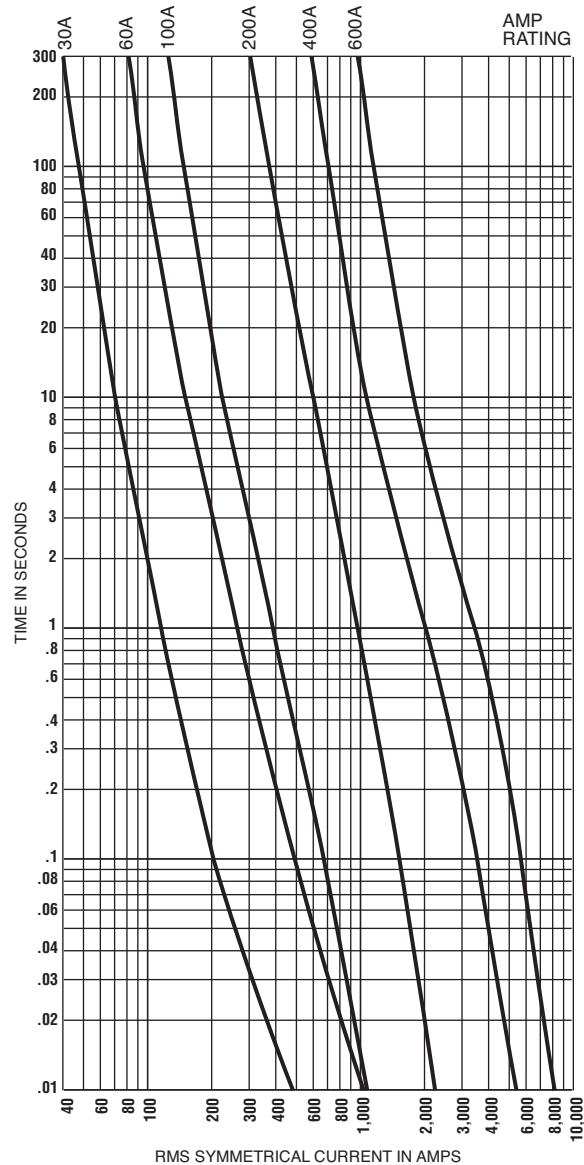

Peak Let-Through Current Curves*

NCLR

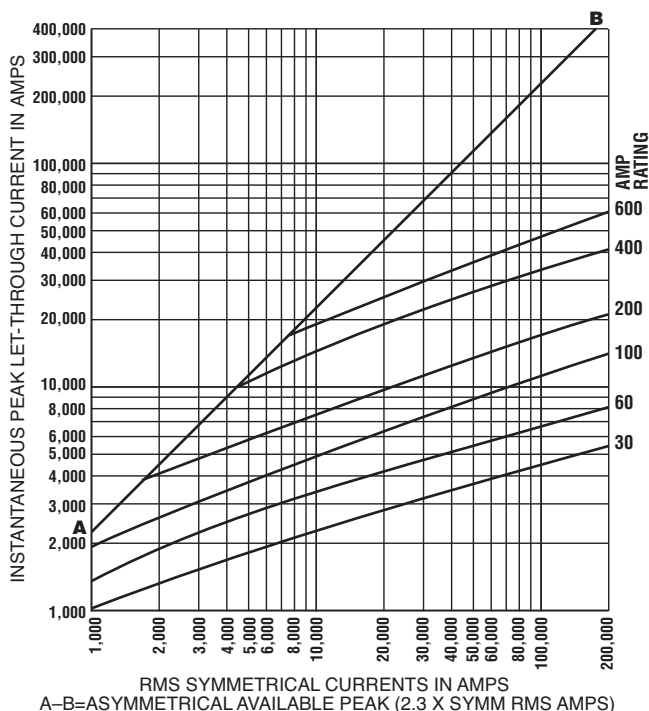

SCLR

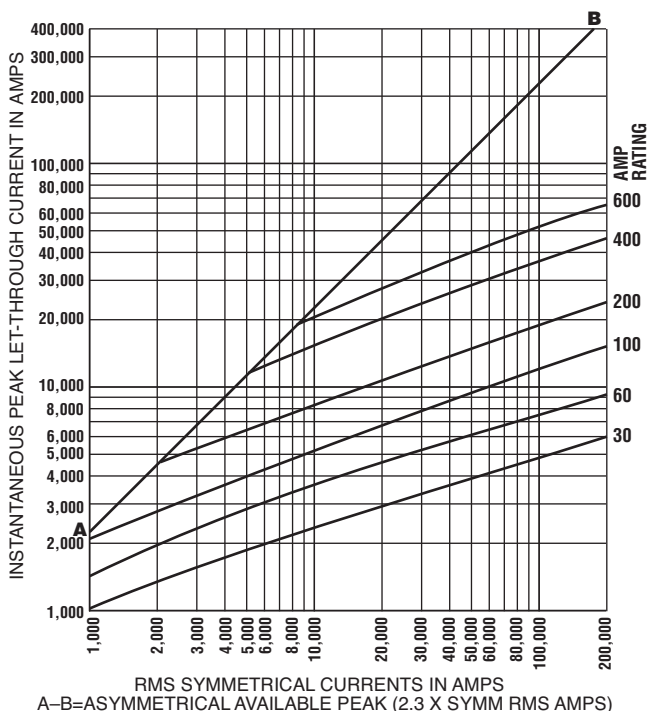

*Curves test data obtained at 15% short-circuit power factor when possible.

Current Limitation Tables**

NCLR

NCLR – RMS & Peak Let-Through Currents (kA)

Prosp. Short C.C.	Fuse Size											
	30		60		100		200		400		600	
	I _{RMS}	I _p	I _{RMS}	I _p	I _{RMS}	I _p	I _{RMS}	I _p	I _{RMS}	I _p	I _{RMS}	I _p
5,000	1	2	1	3	2	4	3	6	5	10	5	12
10,000	1	2	1	3	2	5	3	8	6	14	8	19
15,000	1	3	2	4	2	6	4	9	7	17	10	22
20,000	1	3	2	4	3	6	4	10	8	19	11	25
25,000	1	3	2	5	3	7	4	10	9	20	12	27
30,000	1	3	2	5	3	7	5	11	10	22	13	29
35,000	1	3	2	5	3	8	5	12	10	23	13	31
40,000	1	3	2	5	3	8	5	12	10	24	14	32
50,000	2	4	2	5	4	9	6	13	11	26	15	36
60,000	2	4	2	6	4	9	6	14	12	28	17	38
70,000	2	4	3	6	4	9	6	15	13	29	17	40
80,000	2	4	3	6	4	10	7	15	13	30	18	42
90,000	2	4	3	6	5	10	7	16	13	31	19	44
100,000	2	4	3	7	5	11	7	17	14	32	20	46
150,000	2	5	3	7	5	13	8	19	16	37	23	53
200,000	2	5	3	8	6	14	9	21	18	41	26	59

SCLR

SCLR – RMS & Peak Let-Through Currents (kA)

Prosp. Short C.C.	Fuse Size											
	30		60		100		200		400		600	
	I _{RMS}	I _p	I _{RMS}	I _p	I _{RMS}	I _p	I _{RMS}	I _p	I _{RMS}	I _p	I _{RMS}	I _p
5,000	1	2	1	3	2	4	3	6	5	12	5	12
10,000	1	2	2	4	2	5	4	8	7	15	9	20
15,000	1	3	2	4	3	6	4	10	8	18	11	24
20,000	1	3	2	5	3	7	5	11	9	20	12	28
25,000	1	3	2	5	3	7	5	12	10	22	13	31
30,000	1	3	2	5	3	8	5	13	10	24	14	33
35,000	2	4	2	5	4	8	6	13	11	25	15	35
40,000	2	4	2	6	4	9	6	14	11	26	16	37
50,000	2	4	3	6	4	9	6	14	12	28	17	40
60,000	2	4	3	6	4	10	7	15	13	30	19	43
70,000	2	4	3	7	5	10	7	16	14	32	20	45
80,000	2	4	3	7	5	11	7	17	14	33	21	48
90,000	2	5	3	7	5	12	8	18	15	35	22	50
100,000	2	5	3	7	5	12	8	19	16	36	23	52
150,000	2	5	4	8	6	14	9	21	18	41	26	60
200,000	3	6	4	9	7	15	10	23	20	46	29	66

***"Apparent Let-Through Amps" values are read from "Peak Let-Through Current Curves" and the peak current value divided by 2.3 Asymmetry Factor.

**Class L Time-Delay Fuses
Class L Fast-Acting Fuses**



**Catalog Number LCL (300 - 6000A) Time-Delay 600Vac or Less
Catalog Number LCU (601 - 6000A) Fast-Acting 600Vac or Less**

Amp Ratings					
LCL					
300*	650	801	1350	1800	3500
400*	700	900	1400	2000	4000
500*	750	1000	1500	2500	—
601	800	1200	1600	3000	—
LCU					
601	800	1350	1800	3000	6000
650	1000	1500	2000	3500	—
700	1200	1600	2500	4000	—

* Not UL Listed (See note below).

LCL: Time-delay of 5 seconds minimum at 500% rated current allows closer sizing.

NOTE: LCL 300 - 500 amp fuses are physically the same as 800 amp size; Use in 800 amp switch where load current is not fully utilized and a smaller fuse amp size is desired. Also useful in new installations to allow for future upgrades in service.

LCL/LCU Specifications

LCL: Time-Delay
LCU: Fast-Acting

Voltage Rating: LCL - 600Vac, LCU - 600Vac

Amp Rating: LCL: 300 - 4000A
LCU: 601 - 6000A

Interrupting Rating: 200kA RMS Symmetrical Amps

Current Limiting: Class L Fuse

Agency Approvals:

UL Listed, Class L, Guide JDDZ, File E162363
CSA Certified HRC-L per C22.2, No. 248.10

Benefits:

- “O-ring” construction insures maximum current limiting ability.
- Silver plated micro-peened terminals.
- High strength melamine fuse tubes.

Applications:

- **LCL:** Recommended for AC power distribution system mains and large feeders.
- **LCU:** Recommended for non-inductive heating and lighting loads. Also suitable for protection of low interrupting rating circuit breakers.

Recommended Sizing:

LCL: 150% or more of motor full load current.

Recommended Upgrade:

None Available.

CROSS REFERENCE		
EDISON	GOULD	LITTELFUSE
LCL	A4BY	KLP-C, KLLU
LCU	None	None

Average Time-Current Curves

Cat. No. LCL (Amp)

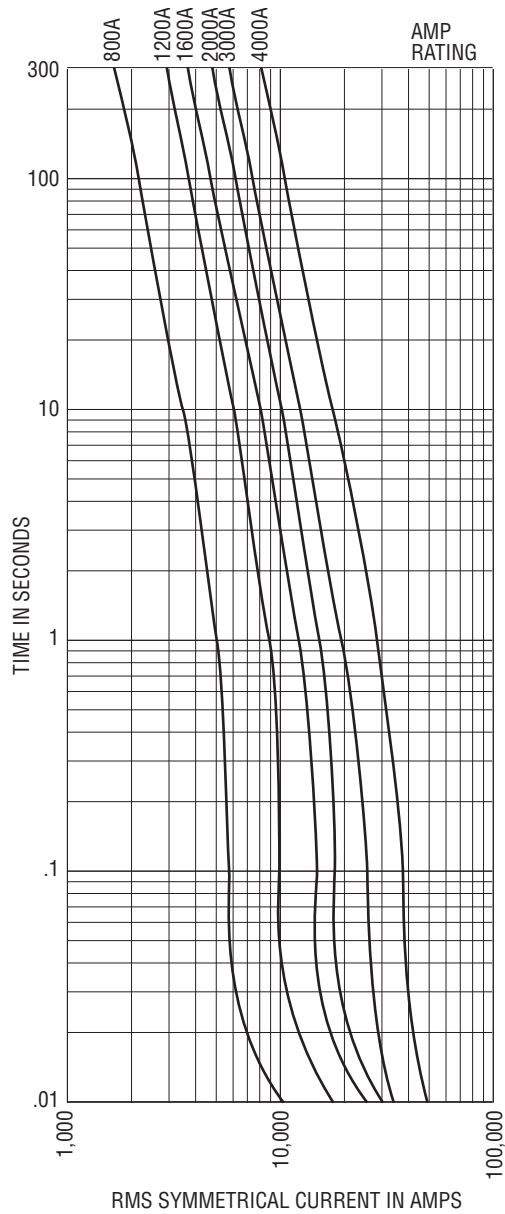

Cat. No. LCU (Amp)

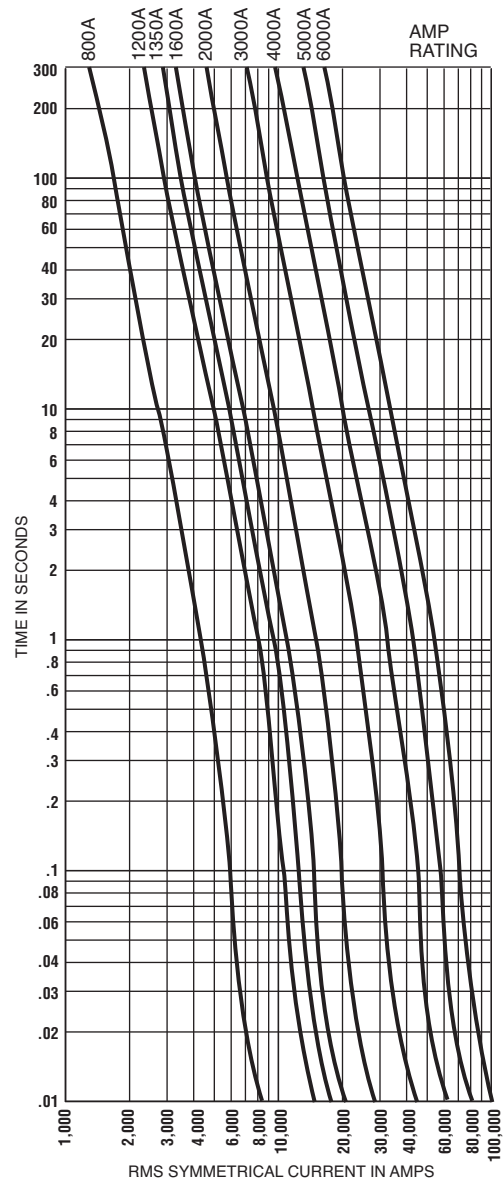

Peak Let-Through Current Curves*

LCL

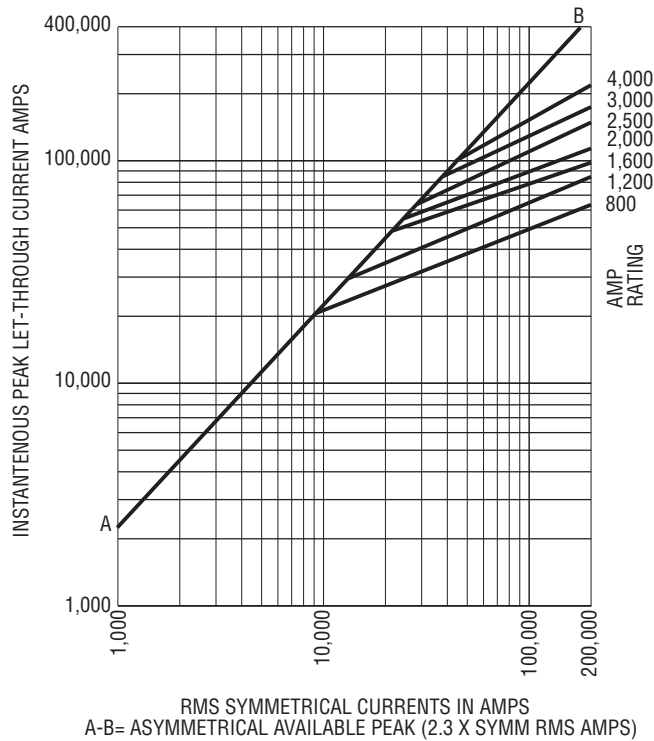

LCU

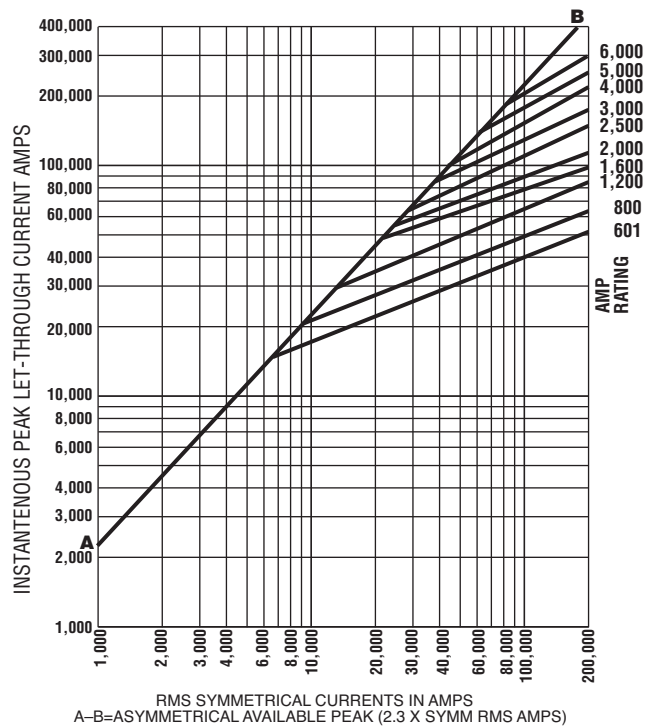

*Curves test data obtained at 15% short-circuit power factor when possible.

Current Limitation Tables**

LCL

Current-Limiting Effects

*Prosp. S.C.C.	Let-Through Current (Apparent RMS Symmetrical) Versus Fuse Ratings						
	800A	1200A	1600A	2000A	3000A	4000A	6000A
5,000	5,000	5,000	5,000	5,000	5,000	5,000	5,000
10,000	10,000	10,000	10,000	10,000	10,000	10,000	10,000
15,000	13,000	15,000	15,000	15,000	15,000	15,000	15,000
20,000	14,000	18,000	20,000	20,000	20,000	20,000	20,000
25,000	16,000	21,000	25,000	25,000	25,000	25,000	25,000
30,000	16,500	22,500	26,000	30,000	30,000	30,000	30,000
40,000	18,000	25,500	29,000	34,000	40,000	40,000	40,000
50,000	19,000	27,000	32,000	37,000	42,000	45,000	50,000
60,000	21,000	29,000	35,000	41,000	45,000	50,000	60,000
80,000	24,000	32,000	39,000	45,000	51,000	57,000	80,000
100,000	26,000	36,000	41,000	51,000	55,000	64,000	90,000
150,000	30,000	40,000	48,000	58,000	66,000	78,000	110,000
200,000	34,000	45,000	52,000	65,000	76,000	92,000	140,000

* RMS Symmetrical Amps Short-Circuit Current.
NOTE: Data derived from Current Limiting Curves.

LCU

Current-Limiting Effects

*Prosp. S.C.C.	Let-Through Current (Apparent RMS Symmetrical) Versus Fuse Ratings							
	800A	1200A	1600A	2000A	3000A	4000A	5000A	6000A
5,000	5,000	5,000	5,000	5,000	5,000	5,000	5,000	5,000
10,000	9,700	10,000	10,000	10,000	10,000	10,000	10,000	10,000
15,000	11,500	13,000	15,000	15,000	15,000	15,000	15,000	15,000
20,000	12,500	15,400	18,000	20,000	20,000	20,000	20,000	20,000
25,000	14,000	16,000	21,000	25,000	25,000	25,000	25,000	25,000
30,000	14,500	17,500	22,000	27,000	30,000	30,000	30,000	30,000
35,000	15,000	18,000	24,000	28,000	35,000	35,000	35,000	35,000
40,000	15,500	19,000	25,000	29,000	40,000	40,000	40,000	40,000
50,000	16,000	21,000	26,000	32,000	44,000	48,000	50,000	50,000
60,000	19,000	24,000	28,000	34,000	48,000	51,000	60,000	60,000
80,000	20,000	26,000	31,000	36,000	52,000	60,000	72,000	80,000
100,000	23,000	29,000	39,000	40,000	57,000	68,000	81,000	95,000
150,000	27,000	34,000	40,000	47,000	70,000	79,000	98,000	115,000
200,000	29,000	39,000	43,000	50,000	78,000	93,000	110,000	141,000

*RMS Symmetrical Amps Short-Circuit Current.
NOTE: Data derived from Current Limiting Curves.

***"Apparent Let-Through Amps" values are read from "Peak Let-Through Current Curves" and the peak current value divided by 2.3 Asymmetry Factor.

General Application:

Edison Class L fuses, Catalog Numbers LCL time-delay or LCU fast acting are recommended for high capacity main, feeder or branch circuits in power distribution systems and for special applications such as system upgrading, install ahead of network protectors, etc. The choice of LCL or LCU depends on the extent of mixed inductive and non-inductive loads diversity. Apply LCL fuses for protection of large individual motor circuits. Size LCL fuses at 150% or more of the motor nameplate current rating by checking starting characteristics against minimum melt Time-Current Curve.

Class L Fuses Specification:

Install Class L Fuses in switches rated 601-6000 amps and in AMP RATINGS and “time-delay” or “fast-acting” types as shown on the plans. Installed and spare

“time-delay” fuses shall be Catalog Number LCL and “fast-acting” fuses shall have silver links and be Catalog Number LCU. Fuses shall be Edison fuses or equivalent submitted to the design engineer for approval 10 days prior to the project bid date.

Mounting of “Bolt-On” Fuses shall be made by installing stainless steel bolts of correct number, diameter and length*, stainless steel spring washers on each side of the bolt and stainless steel nuts. The nuts shall be tightened to the torque recommended by ASTM Standards for the bolt size used.

*Bolts shall have the largest diameter to fit fuse bolt holes and length to allow full nut thread engagement. Bolts shall be installed in each fuse mounting hole.

Class L Fuse Dimensions - inches

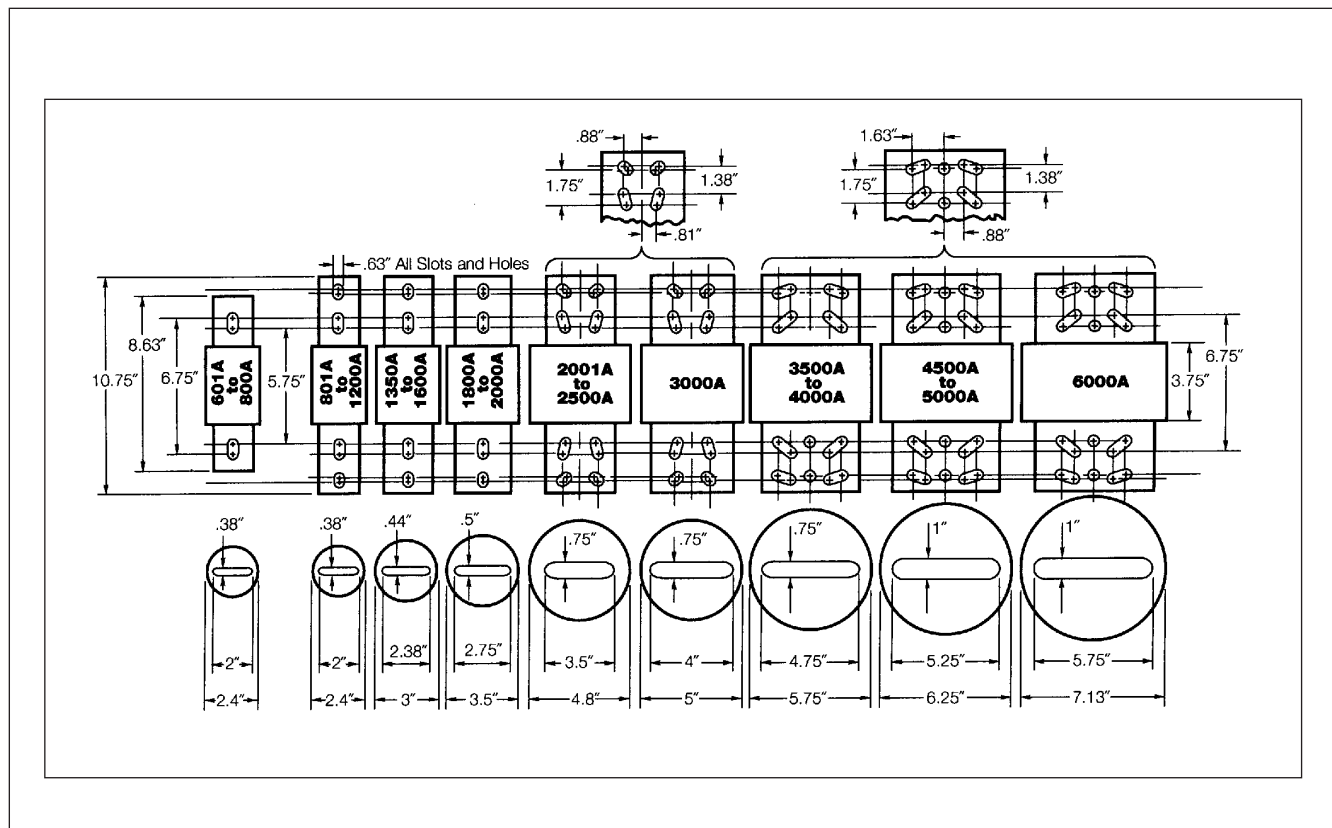

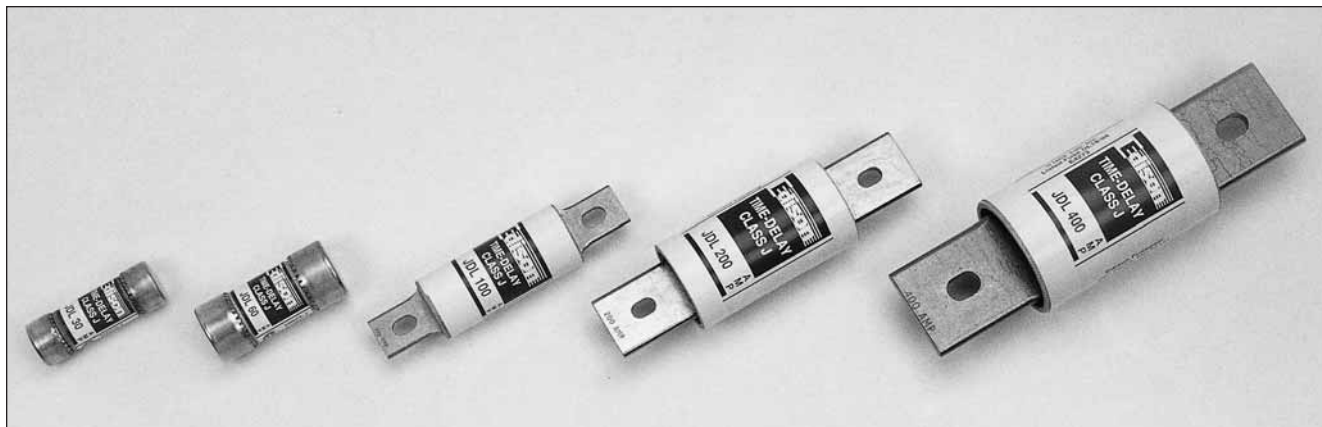

Catalog Number JDL (1 - 600A) 600Vac or Less

Amp Ratings					
JDL					
1	4	12	40	100	250
1.25	5	15	45	110	300
1.6	5.6	17.5	50	125	350
2	6	20	60	150	400
2.5	7	25	70	175	450
3	8	30	80	200	500
3.5	10	35	90	225	600

Edison JDL Class J fuses are among the most current limiting time-delay fuses available. Their small physical size and high performance characteristics makes Class J fuses ideal for any space-limited application.

JDL Specifications

Dual-Element, Time-Delay

Voltage Rating: JDL - 600Vac

Amp Rating: 1 - 600A

Interrupting Rating: 200kA RMS Symmetrical Amps

Current Limiting: Class J Fuse

Agency Approvals:

UL Listed, Class J, Guide JDDZ, File E162363
CSA Certified per C22.2, No. 248.8

Self-Certified DC Ratings:

Voltage Rating: JDL (1-600) 300Vdc

Interrupting Rating: JDL 20kA DC

Benefits:

- Space saving dimensions vs. Class R.
- Dual-Element construction provides superior time-delay to pass harmless motor or transformer surges.
- High performance with fatigue - free cycling capabilities.
- Extremely current limiting.

Applications:

- Recommended for Type 2 "No Damage" protection of IEC style motor starters and contactors.
- Use to protect lower interrupting rating circuit breakers.
- All general purpose circuits with inductive (high inrush) loads, including motor and motor branch circuits, and transformer circuits. Also suitable for lighting loads.

Recommend Fuse Blocks:

Refer to page 129 in this catalog.

Recommend Upgrade:

None.

CROSS REFERENCE		
EDISON	GOULD	LITTELFUSE
JDL	AJT	JTD

Average Time-Current Curve

Cat. No. JDL (Amp)

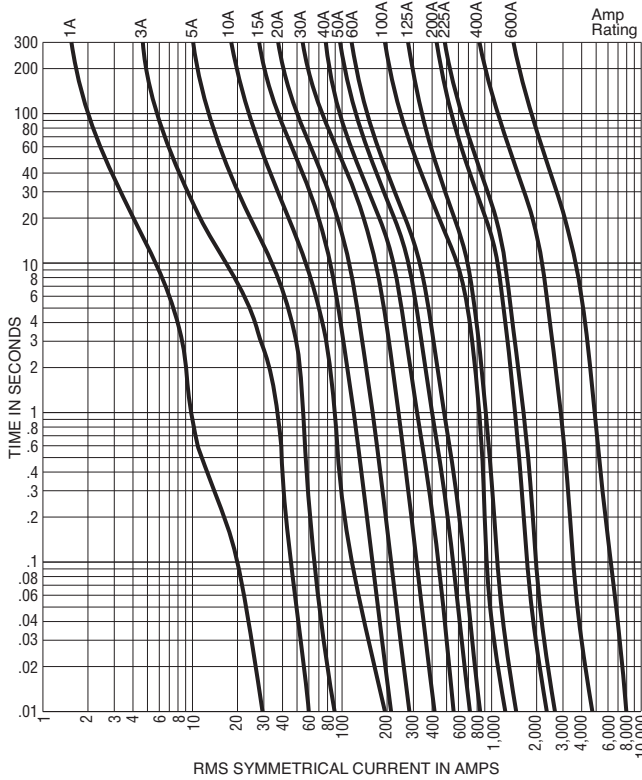

Peak Let-Through Current Curves

Cat. No. JDL (Amp)

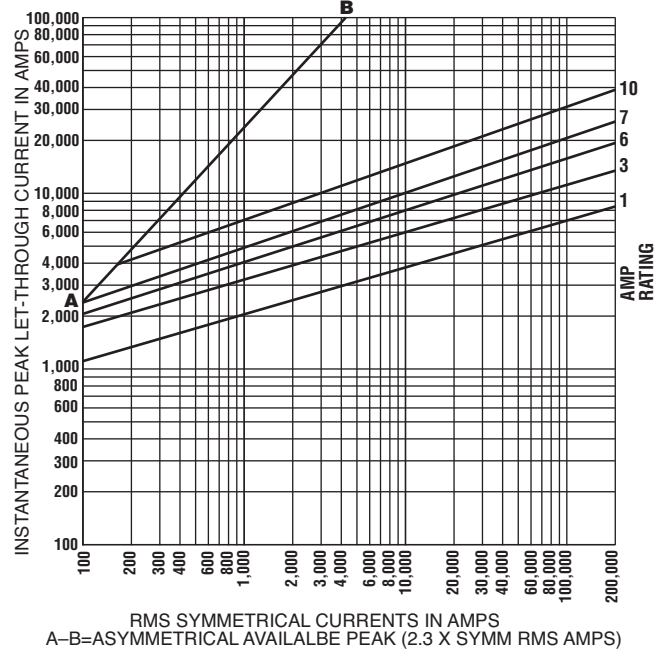

RMS SYMMETRICAL CURRENTS IN AMPS
A-B=ASYMMETRICAL AVAILABLE PEAK (2.3 X SYMM RMS AMPS)

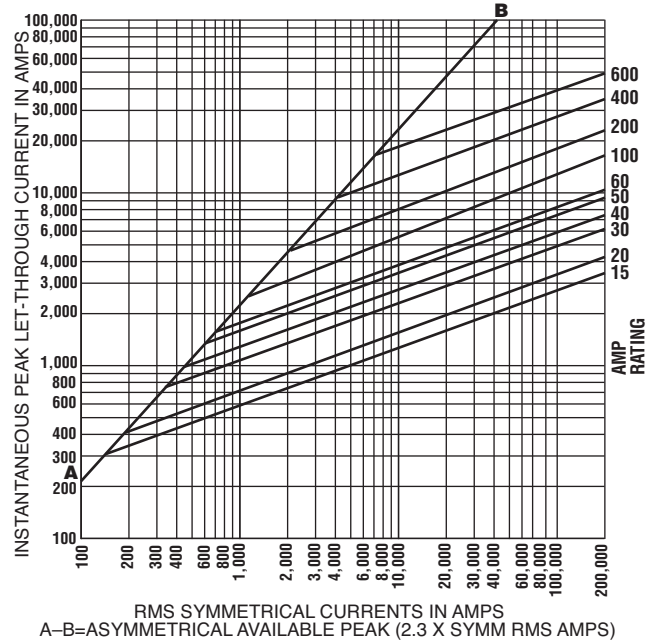

RMS SYMMETRICAL CURRENTS IN AMPS
A-B=ASYMMETRICAL AVAILABLE PEAK (2.3 X SYMM RMS AMPS)

Current-Limiting Effects

*Prop. S.C.C.	Let-Through Current (Apparent RMS Symmetrical)						
	JDL Fuse Ratings						
	15A	30A	60A	100A	200A	400A	600A
1,000	270	470	750	—	—	—	—±
3,000	370	670	1,130	1,640	2,360	—	—
5,000	450	800	1,420	1,910	2,760	4,400	—
10,000	550	1,000	1,730	2,450	3,520	5,540	8,000
15,000	625	1,220	1,890	2,850	4,000	6,420	9,000
20,000	700	1,330	2,120	3,090	4,400	7,000	10,000
25,000	750	1,440	2,250	3,400	5,000	7,500	11,100
30,000	800	1,530	2,370	3,650	5,140	8,000	11,800
35,000	820	1,600	2,580	3,780	5,430	8,330	12,500
40,000	900	1,640	2,670	4,000	5,640	9,000	13,270
50,000	925	1,760	2,790	4,470	6,000	9,380	13,820
60,000	1,000	1,850	3,000	4,670	6,420	10,000	15,000
80,000	1,160	2,000	3,220	5,000	7,400	11,270	16,000
100,000	1,220	2,150	3,520	5,360	7,950	12,180	17,270
150,000	1,400	2,460	4,000	6,170	9,000	14,360	19,270
200,000	1,560	2,640	4,450	7,000	10,000	15,820	20,600

*RMS Symmetrical Amps Short-Circuit Current.
NOTE: Data derived from Current Limiting Curves.

Dimensions
Refer to JFL Section on page 21.

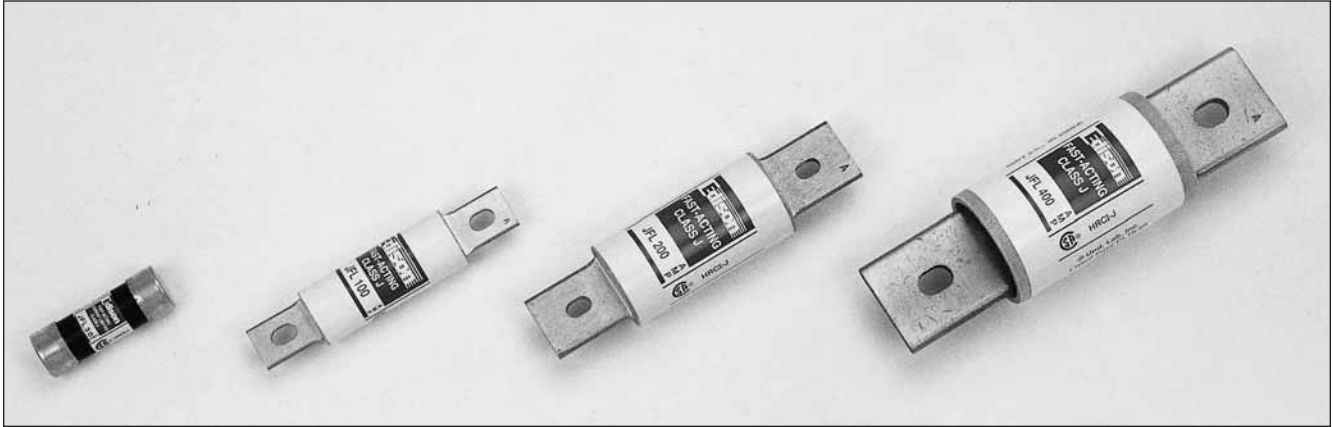

Catalog Number JFL (1 - 600A) 600Vac or Less

Amp Ratings					
JFL					
1	8	30	70	150	350
2	10	35	80	175	400
3	12	40	90	200	450
4	15	45	100	225	500
5	20	50	110	250	600
6	25	60	125	300	—

JFL Specifications

Fast-Acting

Voltage Rating: JFL - 600Vac

Amp Rating: 1 - 600A

Interrupting Rating: 200kA RMS Symmetrical Amps

Current Limiting: Class J Fuse

Agency Approvals:

UL Listed, Class J, Guide JDDZ, File E162363
CSA Certified per C22.2, No. 248.8

Edison JFL Class J fuses are among the most current limiting fuses available. Their small physical size and high performance characteristics makes Class J fuses ideal for any space - limited application.

Edison JFL fuses are best suited for the protection of non-inductive loads such as resistive heating, and lighting circuits.

Benefits:

- Space saving dimensions vs. Class R.
- Fast-acting design permits quick response for both overloads and shorts.
- Extremely current-limiting.

Applications:

- Recommended for protection of non-inductive loads, such as lighting and resistance heating circuits.
- For motor applications, refer to Edison JDL.

Recommended Fuse Blocks:

Refer to page 129 in this catalog.

Recommended Upgrade:

JDL.

CROSS REFERENCE		
EDISON	GOULD	LITTELFUSE
JFL	A4J	JLS

Cat No. JFL and JDL Dimensions - inches

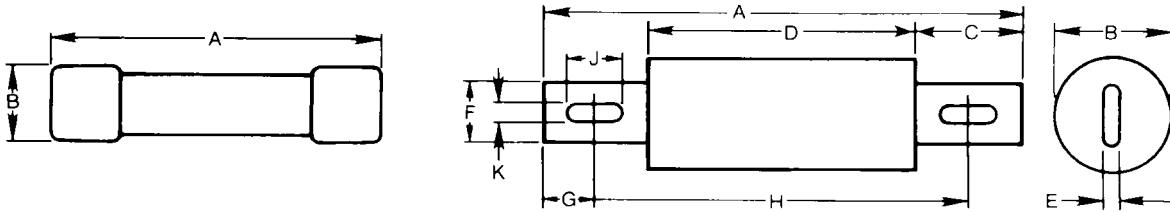

Amp Rating Range	Overall Length A	Max. Dia. B	Blade Length C	Barrel Length D	Blade Thickness E	Blade Width F	Mounting Hole Spacing			
							G	H	J	K
1-30	2-1/4	13/16	-	-	-	-	-	-	-	-
35-60	2-3/8	1-1/16	-	-	-	-	-	-	-	-
70-100	4-5/8	1-1/18	1	2-5/8	1/8	3/4	1/2	3-5/8	3/8	9/32
110-200	5-3/4	1-5/8	1-3/8	3	3/16	1-1/8	11/16	4-3/8	3/8	9/32
225-400	7-1/8	2-1/8	1-7/8	3-3/8	1/4	1-5/8	15/16	5-1/4	17/32	13/32
450-600	8	2-5/8	2-1/8	3-3/4	3/8	2	1	6	11/16	17/32

Average Time-Current Curve
 Cat. No. JFL (Amp)

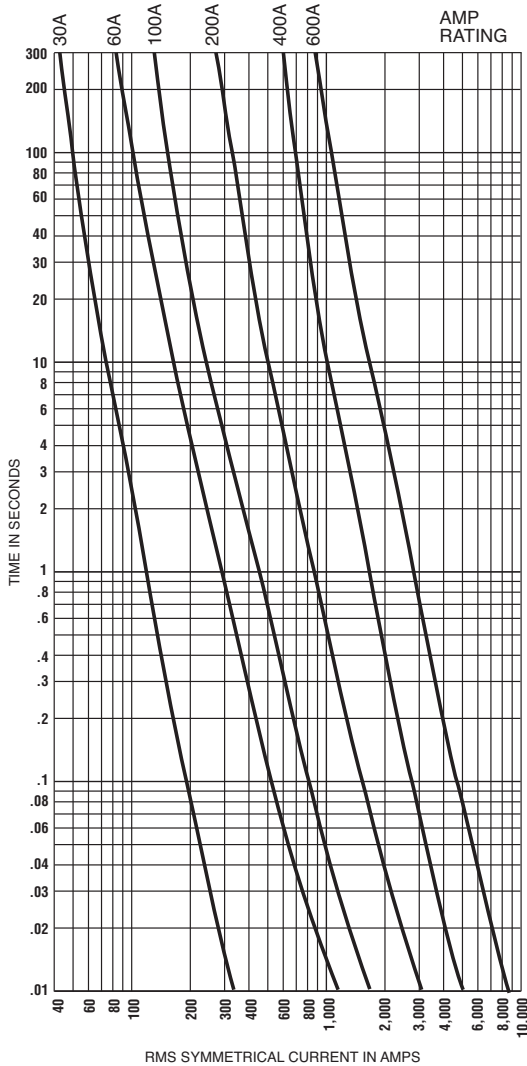

Current Limitation Table*
 JFL

Prosp. Short C.C.	Fuse Size											
	30		60		100		200		400		600	
	I _{RMS}	I _p	I _{RMS}	I _p	I _{RMS}	I _p	I _{RMS}	I _p	I _{RMS}	I _p	I _{RMS}	I _p
5,000	1	2	1	3	2	4	3	7	4	10	5	12
10,000	1	3	2	4	3	6	4	9	6	13	9	19
15,000	1	3	2	4	3	6	4	10	7	15	10	22
20,000	1	3	2	5	3	7	5	12	8	18	11	25
25,000	2	4	3	6	3	8	6	13	9	19	12	28
30,000	2	4	3	6	3	8	6	13	9	20	13	30
35,000	2	4	3	7	4	9	6	14	9	21	13	30
40,000	2	4	3	7	4	9	7	15	10	22	14	32
50,000	2	5	3	8	4	10	7	16	10	23	15	35
60,000	2	5	3	8	5	11	7	17	11	25	16	37
70,000	2	5	3	8	5	12	8	18	11	25	17	39
80,000	2	5	3	8	5	12	8	18	12	28	17	39
90,000	2	5	4	9	6	13	9	19	13	29	18	41
100,000	2	5	4	9	6	13	9	19	13	30	18	42
150,000	2	5	5	11	6	14	9	21	14	33	22	50
200,000	3	6	5	12	7	15	10	22	16	37	24	55

Peak Let-Through Current Curves**

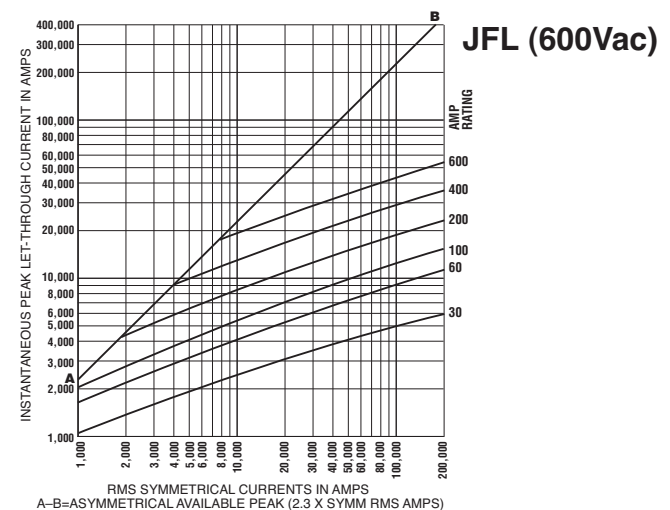

* "Apparent Let-Through Amps" values are read from "Peak Let-Through Current Curves" and the peak current value divided by 2.3 Asymmetry Factor.

** Curves test data obtained at 15% short-circuit power factor when possible.

TJN (300Vac) Class T Fast-Acting Fuses
TJS (600Vac) Class T Fast-Acting Fuses

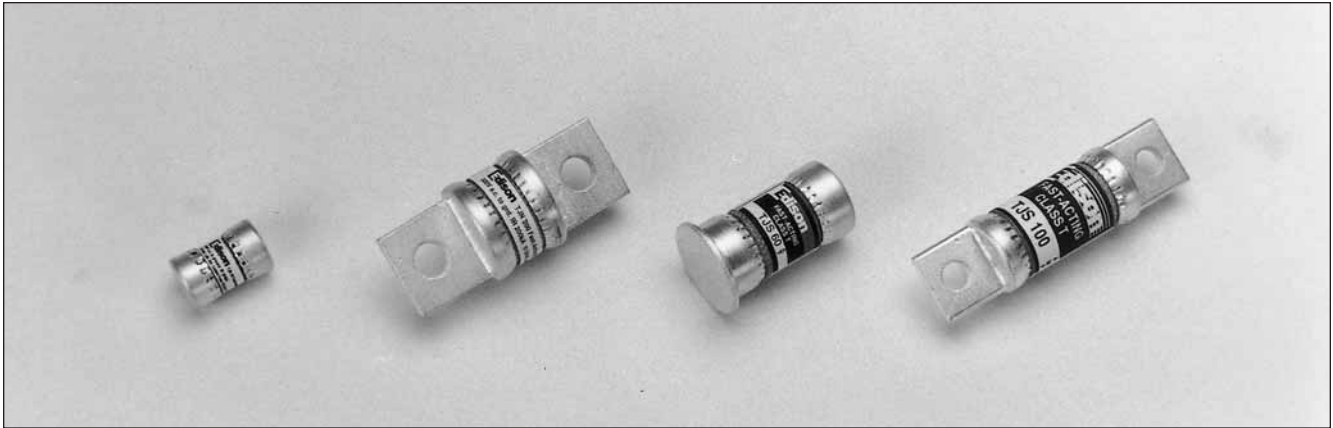

Catalog Number TJN (1 - 1200A) 300Vac or Less
Catalog Number TJS (1 - 800A) 600Vac or Less

Amp Ratings					
TJN					
1	30	70	150	350	800
3	35	80	175	400	1000
6	40	90	200	450	1200
10	45	100	225	500	—
15	50	110	250	600	—
20	60	125	300	700	—
TJS					
1	25	60	125	300	800
3	30	70	150	350	—
6	35	80	175	400	—
10	40	90	200	450	—
15	45	100	225	500	—
20	50	110	250	600	—

Edison Class T fuses are extremely fast-acting fuses in a compact, space saving size. These fuses are ideal as the main fuse protection for panelboards, load centers and meter stacks.

Benefits:

- No intentional time-delay; opens quickly on overload.
- Extremely current-limiting silver link construction; provides superior short-circuit component protection.

Applications:

- Recommended for protection of non-inductive loads, such as lighting and resistance heating circuits.
- Use to protect lower interrupting rating circuit breakers when series rated with Class T fuses.
- For motor protection, size at 300% FLA which provides short-circuit protection only.

TJN/TJS Specifications

Extremely Fast-Acting

Voltage Rating: TJN - 300Vac, TJS - 600Vac

Amp Rating: TJN: 1 - 1200A TJS: 1 - 800A

Interrupting Rating: 200kA RMS Symmetrical Amps

Current Limiting: Class T Fuse

Agency Approvals:

UL Listed, Class T, Guide JDDZ,, File E162363
CSA Certified per C22.2, No. 248.15, LR700489

Self-Certified DC Ratings:

Voltage Rating: TJN (15-1200) 160Vdc

Interrupting Rating:

TJN (15-600) 20kA Amps DC
TJN (601-1200) 100kA Amps DC

Recommended Fuse Blocks:

Refer to page 130 in this catalog.

Recommended Upgrade:

None Available.

CROSS REFERENCE			
VOLTS	EDISON	GOULD	LITTELFUSE
300	TJN	A3T	JLLN
600	TJS	A6T	JLLS

Average Time-Current Curve
Cat. No. TJN (Amp)

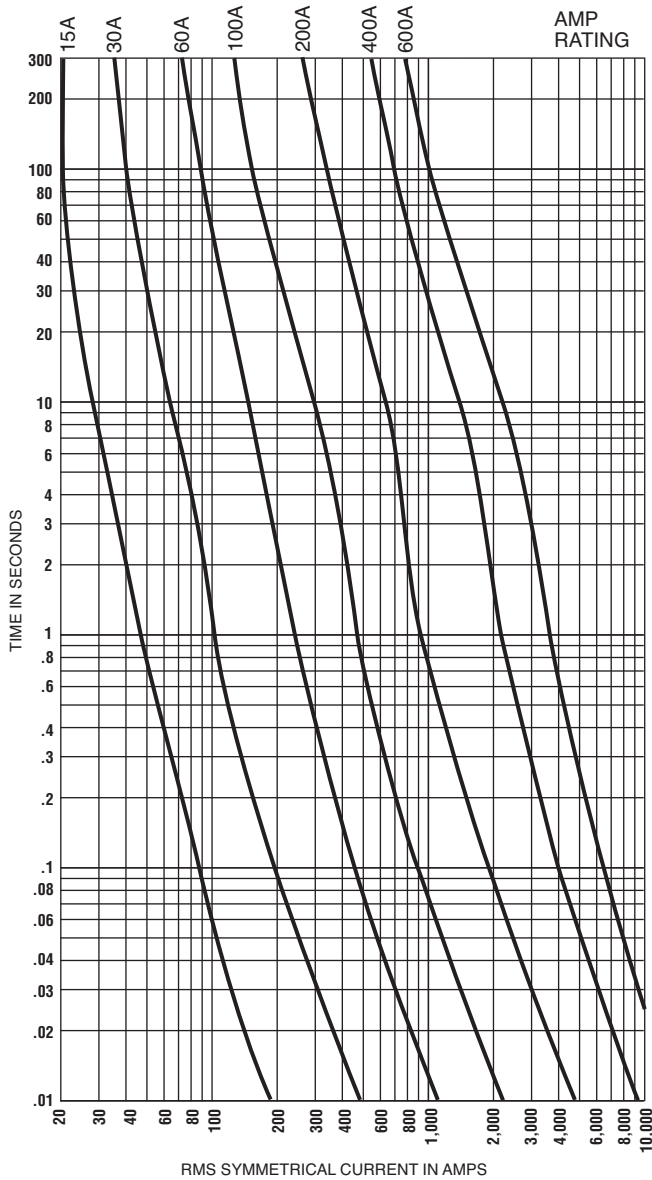

Peak Let-Through Current Curve
Cat. No. TJN (Amp)

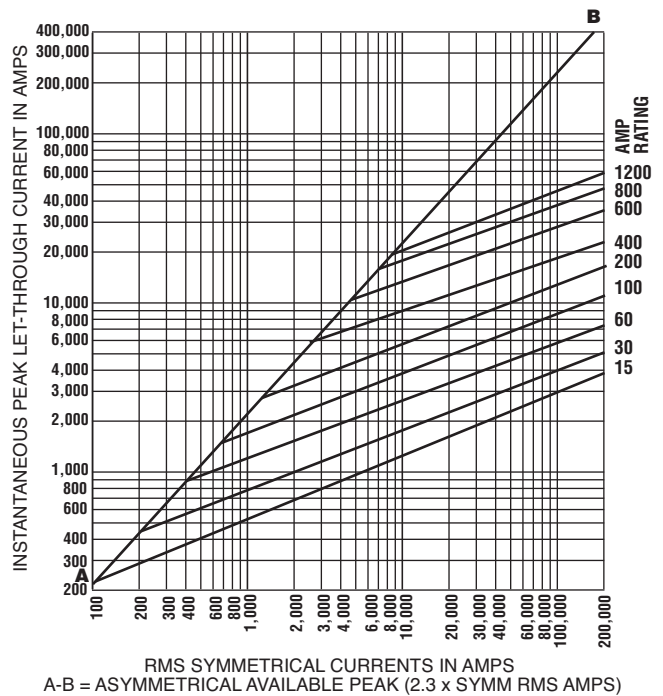

TJN Dimensions - in

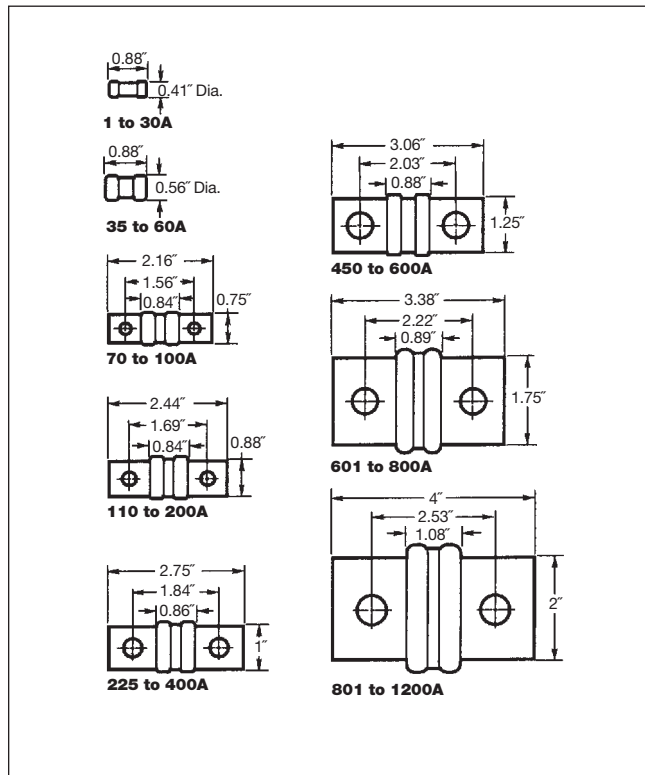

Average Time-Current Curve
Cat. No. TJS (Amp)

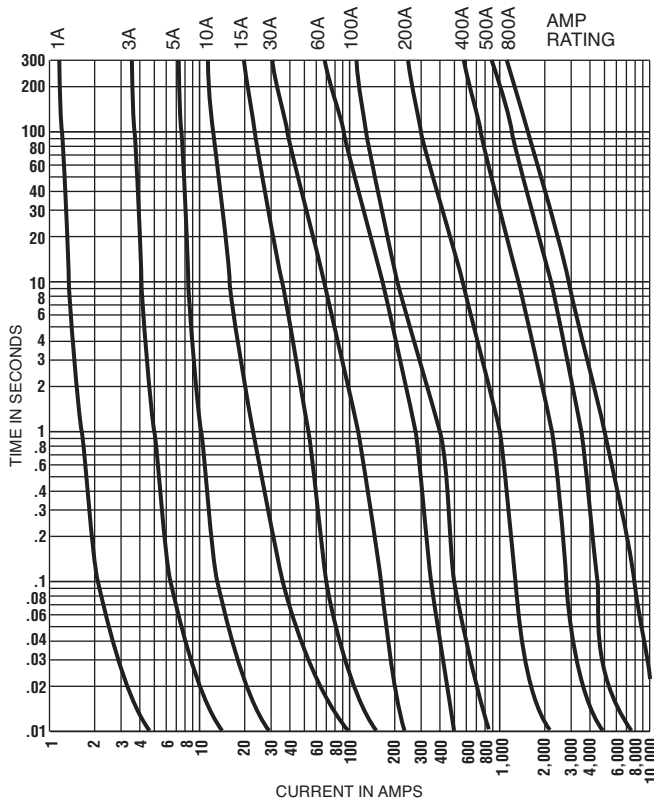

Peak Let-Through Current Curve
Cat. No. TJS (Amp)

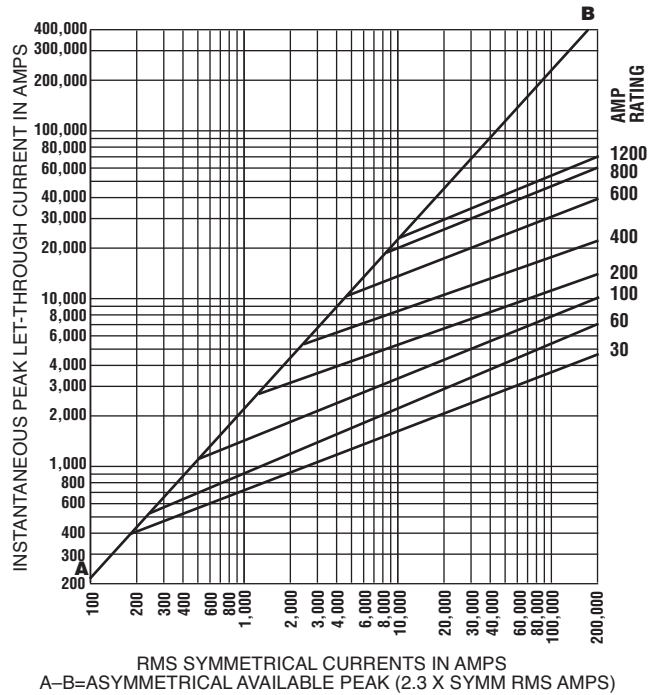

TJS Dimensions - inches

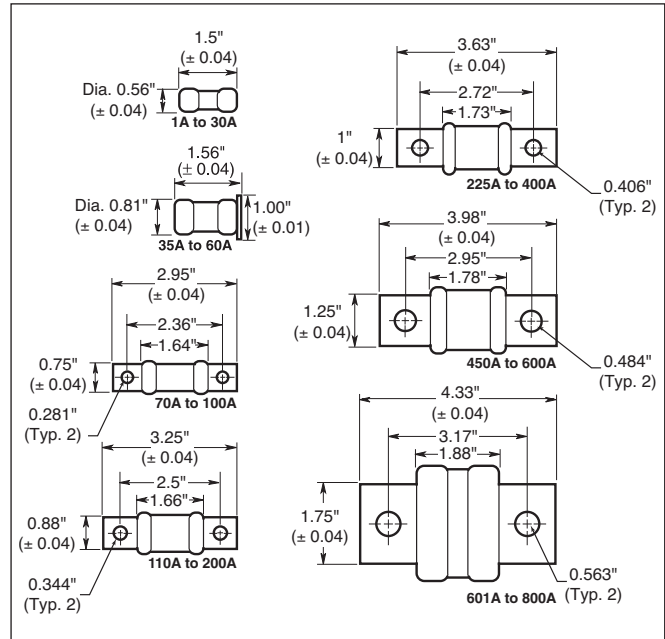

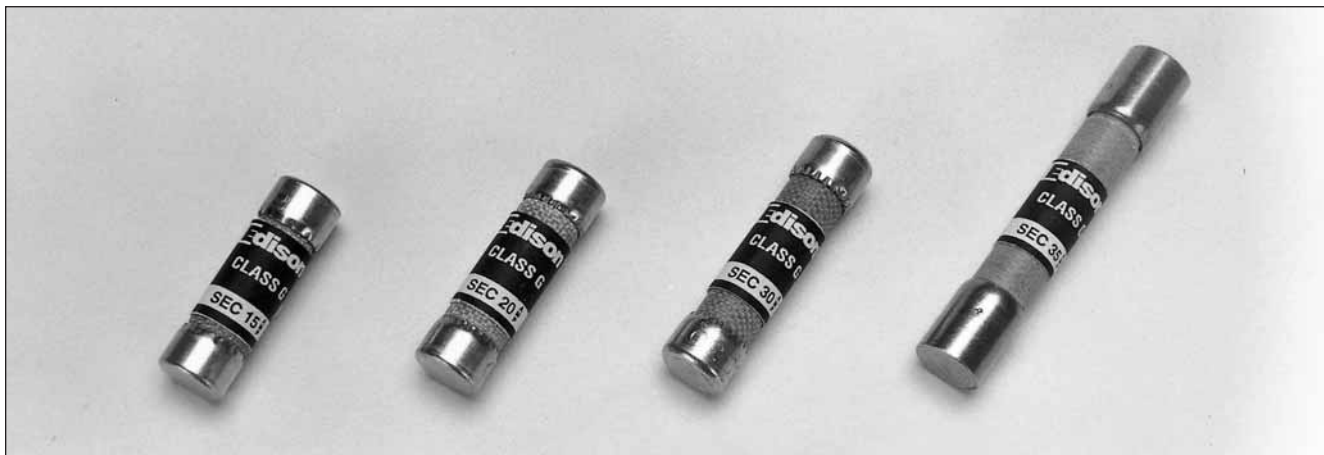

Catalog Number SEC (0.5 - 60A) 600Vac or Less

Amp Ratings				
SEC				
.5	3	8	25	45
1	4	10	30	50
1.5	5	15	35	60
2	6	20	40	—

Dimensions - inches		
Amps	Ferrule Diameter	Length
1 - 15	0.41	1.31
20	0.41	1.41
25 - 30	0.41	1.63
35 - 60	0.41	2.25

SEC Specifications

Fast-Acting; Time-Delay*

Voltage Rating: SEC 0.5 to 20 600Vac
SEC 25 to 60 480Vac

Amp Rating: 0.5 to 6A (fast-acting),
7 to 60A (time-delay)

Interrupting Rating: 100kA RMS Symmetrical Amps

Current Limiting: Class G Fuse

Agency Approvals:

UL Listed, Std. 248-5, Class G, Guide JDDZ, File E162363
CSA Certified, C22.2 No. 248.5, Class 1422-01, File 700489

Self-Certified DC Ratings:

Voltage Rating: SEC (0.5-20A) 170Vdc;
SEC (30 and 60A only) 300Vdc

Interrupting Rating: 10kA Amps DC

*Fast-acting/time-delay varies by amp rating

Benefits:

- Branch circuit rated for 480Vac.
- Compact size features varying length rejection feature which helps prevent overfusing.
- Time-delay of 12 sec. min. at 200% rating for amp sizes 6 through 60.

Applications:

- General purpose for use in 120/208 and 277/480 circuits. Ideal for fluorescent fixture protection.
- Light inductive loads including motors, solenoids, etc. (For additional delay, refer to Edison EDCC or JDL).

Recommended Fuse Blocks:

Refer to page 132 in this catalog.

Recommended Upgrade:

None Available.

CROSS REFERENCE		
EDISON	GOULD	LITTELFUSE
SEC	AG	SLC

**Average Time-Current Curve
Cat. No. SEC (Amp)**

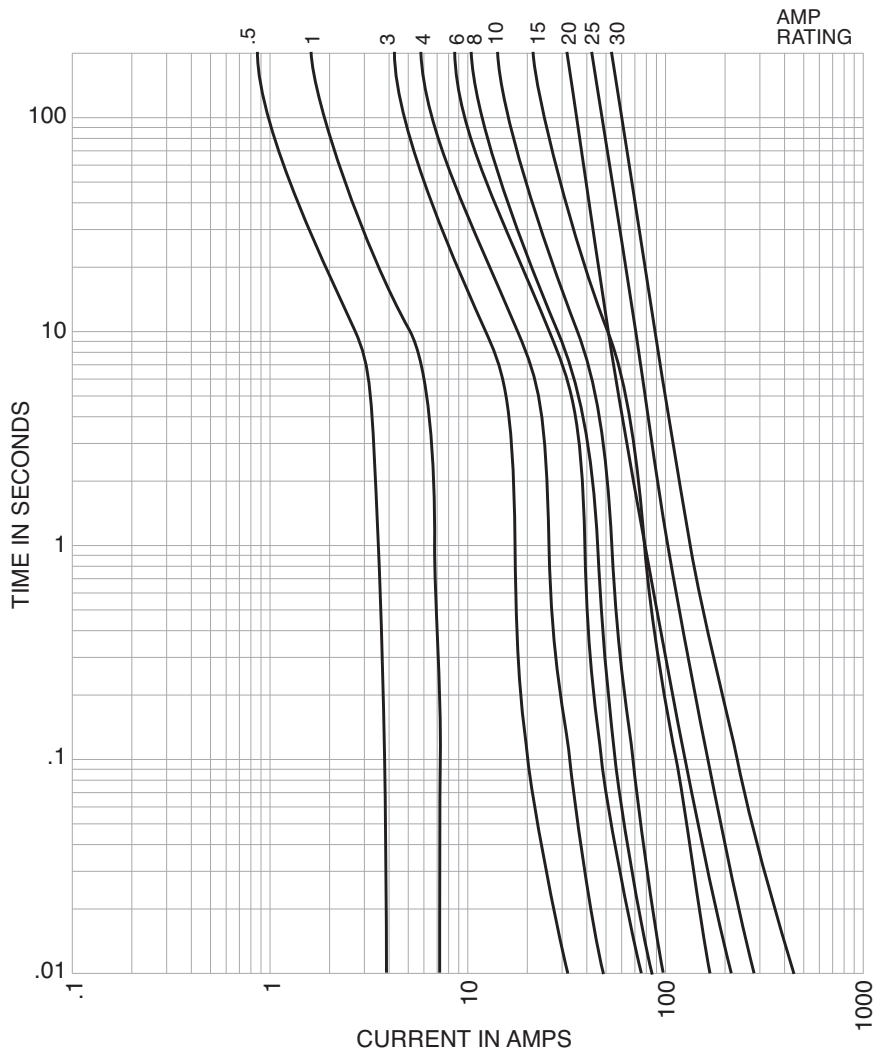

**Peak Let-Through Current Curve
Cat. No. SEC (Amp)**

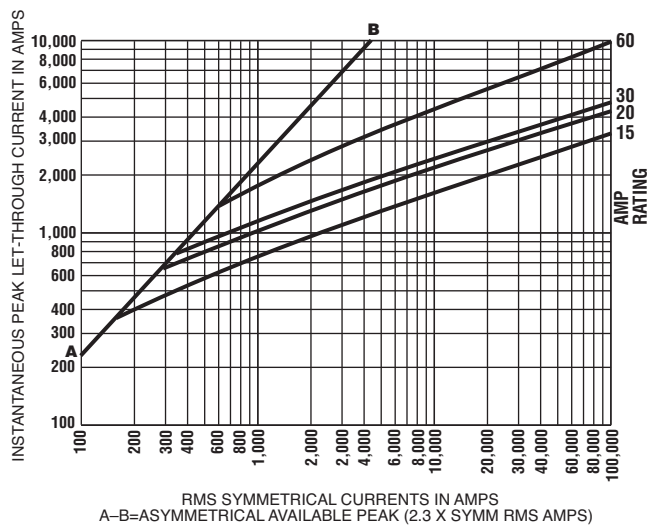



Catalog Number EDCC (0.5 - 30A) 600Vac or Less

Amp Ratings				
EDCC				
0.5	1.5	3	6	12
0.6	1.6	3.2	6.25	15
0.8	1.8	3.5	7	20
1	2	4	7.5	25
1.125	2.25	4.5	8	30
1.25	2.5	5	9	—
1.4	2.8	5.6	10	—

Dimensions - inches		
Amps	Ferrule	Length
0.5 - 30	13/32	1-1/2

Edison EDCC Class CC fuses are extremely current-limiting fuses in a compact size.

EDCC fuses are designed specifically for the protection of small horsepower motor circuits.

Recommended sizing for most applications is 200% FLA. Refer to time-current curves for specific applications.

EDCC Specifications

Time-Delay

Voltage Rating: EDCC - 600Vac

Amp Rating: 0.5 - 30A

Interrupting Rating: 200kA RMS Symmetrical Amps

Current Limiting: Class CC Fuse

Agency Approvals:

UL Listed, Class CC, Guide JDDZ, File E162363
CSA Certified per C22.2, No. 248.4

UL Listed DC Rating:

Voltage Rating: EDCC 0.5-2.8A, 20-30A 300Vdc
3-15A 150Vdc

Interrupting Rating: 20kA Amps DC

Benefits:

- Branch circuit rated for 600Vac.
- Time-delay for motor branch circuit protection.
- Excellent current-limiting performance.
- Upgrade for standard "midget" fuses.

Applications:

- Use for protection of small horsepower motor circuits or other circuits requiring small dimension, time-delay fuses.
- Can provide Type 2 "No Damage" protection for IEC or NEMA starters/contactors.
- For control transformer applications, refer to HCTR.

Recommended Fuse Blocks:

Refer to page 133 in this catalog.

Recommended Inline Fuse Holders:

Refer to page 146 in this catalog.

Recommended Panel Mount Holders:

Refer to page 149 in this catalog.

Recommended Upgrade:

None Available.

CROSS REFERENCE		
EDISON	GOULD	LITTELFUSE
EDCC	ATDR	CCMR

Time- Current Characteristics Curve Average Melt EDCC Fuses

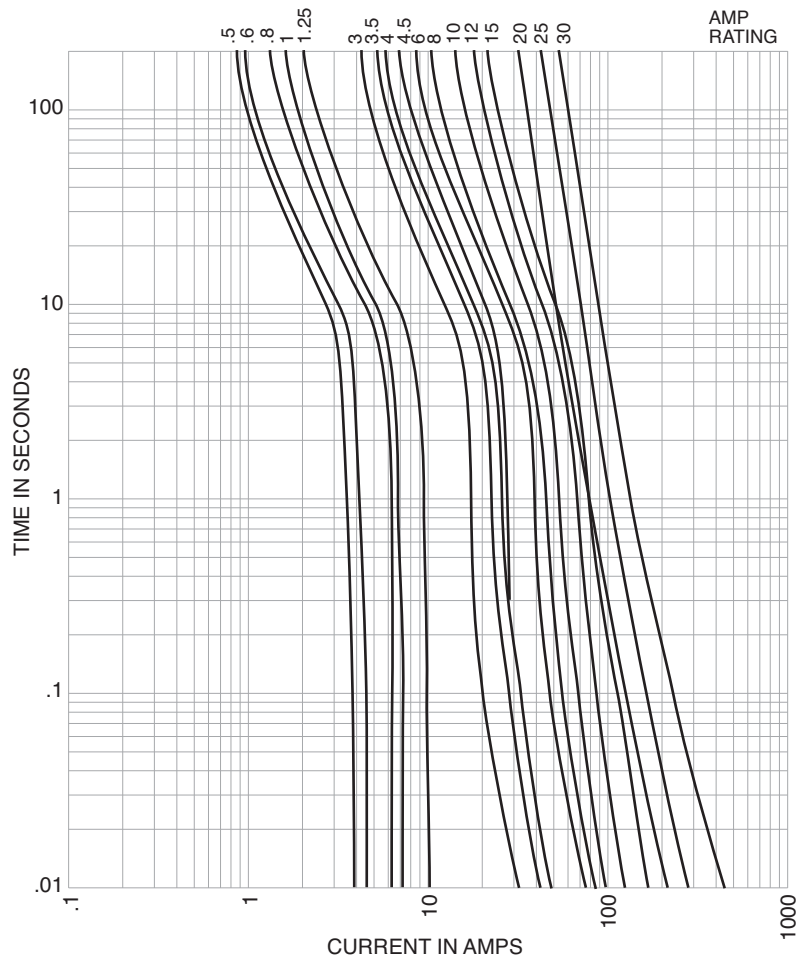

Current-Limiting Effects EDCC Fuse Rating

*Prospective Short-Circuit Current	Let-Through Current (Apparent RMS Symmetrical) Versus Fuse Ratings					
	1.25A	2.8A	15A	20A	25A	30A
1000	100	135	240	305	380	435
3000	140	210	350	440	575	580
5000	165	255	420	570	690	710
10,000	210	340	540	700	870	1,000
20,000	260	435	680	870	1,090	1,305
30,000	290	525	800	1,030	1,300	1,520
40,000	315	610	870	1,150	1,390	1,700
50,000	340	650	915	1,215	1,520	1,820
60,000	350	735	1,050	1,300	1,650	1,980
80,000	390	785	1,130	1,500	1,780	2,180
100,000	420	830	1,210	1,600	2,000	2,400
200,000	525	1,100	1,600	2,000	2,520	3,050

*RMS Symmetrical amps short-circuit current.
NOTE: To calculate I_p (I_{peak}) multiply I_{RMS} value x 2.3.



**Catalog Number HCLR (0.1 - 30A)
600Vac or Less
Fast-Acting**

Amp Ratings				
0.1	0.5	2.5	6	12
0.125	0.75	3	7	15
0.2	1	3.5	8	20
0.25	1.5	4	9	25
0.3	2	5	10	30

Dimensions - inches		
Amps	Ferrule	Length
0.1 - 30	13/32	1-1/2

HCLR Specifications

Fast-Acting

Voltage Rating: HCLR - 600Vac

Amp Rating: 0.1 - 30A

Interrupting Rating: 200kA RMS Symmetrical Amps

Current Limiting: Class CC Fuse

Agency Approvals:

UL Listed, Class CC, Guide JDDZ, File E162363
CSA Certified per C22.2, No. 248.4

Benefits:

- Branch circuit rated for 600Vac.
- Compact dimensions.
- Fast-acting design responds quickly to both overload and short-circuit current.

Applications:

- Lighting and resistive heating loads.

Recommended Fuse Blocks:

Refer to page 133 in this catalog.

Recommended Inline Fuse Holders:

Refer to page 146 in this catalog.

Recommended Panel Mount Holders:

Refer to page 149 in this catalog.

CROSS REFERENCE		
EDISON	GOULD	LITTELFUSE
HCLR	ATMR	KLKR



**Catalog Number HCTR (0.25 - 30A)
600Vac or Less
Time-Delay**

Amp Ratings						
0.25	0.75	1.3	2	3.2	6.25	12
0.3	0.8	1.4	2.25	3.5	7.5	15
0.4	1	1.5	2.5	4	8	20
0.5	1.125	1.6	2.8	5	9	25
0.6	1.25	1.8	3	6	10	30

Dimensions - inches		
Amps	Ferrule	Length
0.25 - 30	13/32	1-1/2

HCTR Specifications

Time-Delay

Voltage Rating: HCTR - 600Vac

Amp Rating: 0.25 - 30A

Interrupting Rating: 200kA RMS Symmetrical Amps

Current Limiting: Class CC Fuse

Agency Approvals:

UL Listed, Class CC, Guide JDDZ, File E162363
CSA Certified per C22.2, No. 248.4

Benefits:

- Branch circuit rated for 600Vac.
- Compact dimensions.
- Time-delay design allows closer sizing for inductive loads such as control transformers and solenoids.

Applications:

- Primary protection for control transformers.

Recommended Fuse Blocks:

Refer to page 133 in this catalog.

Recommended Inline Fuse Holders:

Refer to page 146 in this catalog.

Recommended Panel Mount Holders:

Refer to page 149 in this catalog.

CROSS REFERENCE		
EDISON	GOULD	LITTELFUSE
HCTR	ATQR	KLDR

Average Time-Current Curve

Cat. No. HCLR (Amp) Fast-Acting

Cat. No. HCTR (Amp) Time-Delay

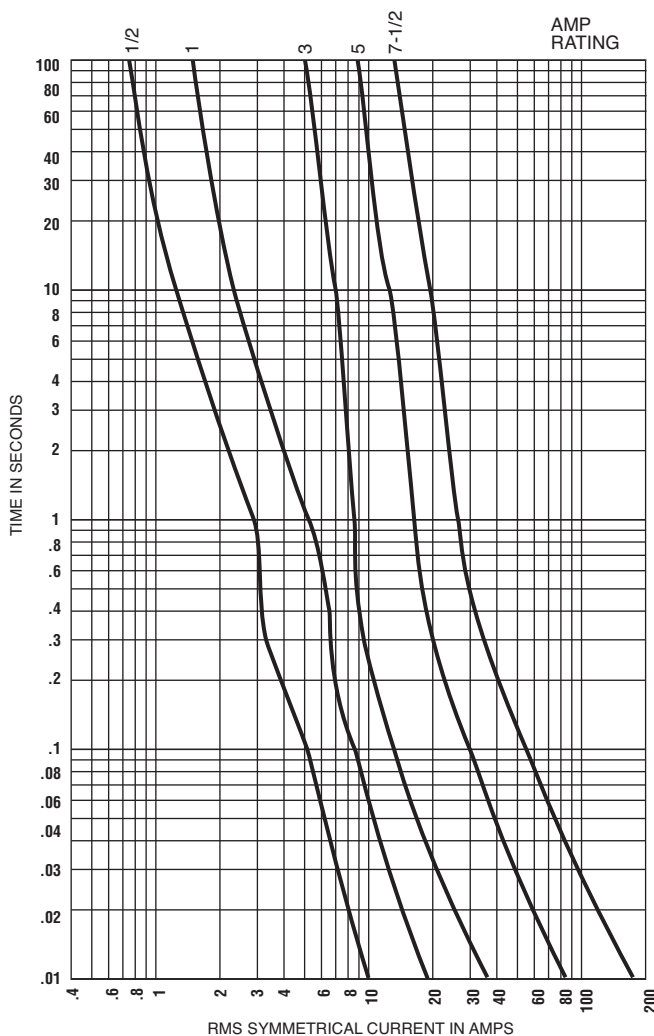
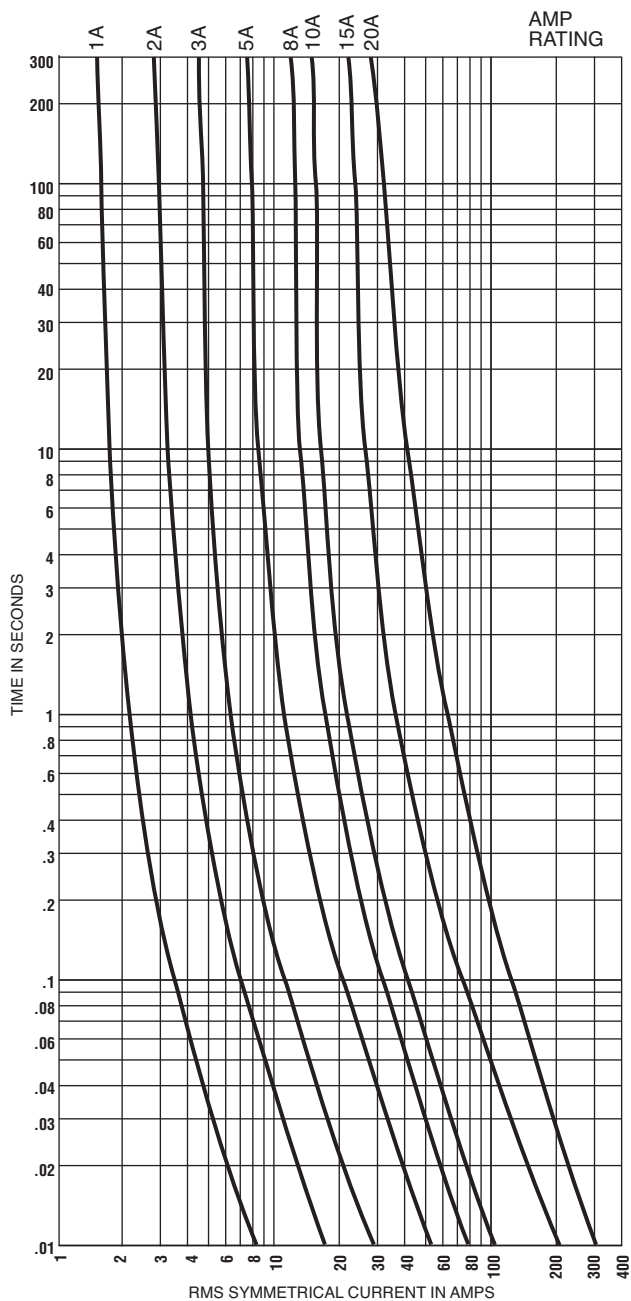



Catalog No. MCL (0.1 - 30A)
600Vac or Less
Fast-Acting

Amp Ratings				
MCL				
0.1	0.75	3.5	9	30
0.125	1	4	10	—
0.2	1.5	5	12	—
0.25	2	6	15	—
0.3	2.5	7	20	—
0.5	3	8	25	—

Dimensions - inches		
Amps	Ferrule	Length
0.1 - 30	13/32	1-1/2

MCL Specifications
Fast-Acting

Voltage Rating: 600Vac

Amp Rating: 0.1 - 30A

Interrupting Rating: 100kA RMS Amps

Agency Approvals:
(0.1 - 30) UL Listed, File E162443
(0.1 - 30) CSA Cert., LR700489

Benefits:

- Compact dimensions.
- High interrupting rating.
- Fast-acting design responds quickly to both overloads and short-circuit current.

Applications:

- Street lighting holders, HID lighting, control circuits, electronic equipment protection.

Recommended Fuse Blocks: Pages 134 & 150. **Recommended Inline Fuse Holders:** Page 146. **Recommended Panel Mount Holders:** Page 149.

CROSS REFERENCE		
EDISON	GOULD	LITTELFUSE
MCL	ATM	KLK



Catalog No. MOL (0.5 - 30A)
250Vac or Less
Fast-Acting

Amp Ratings				
MOL				
0.5	2.5	6	10	25
1	3	6.5	12	30
1.5	4	8	15	—
2	5	9	20	—

Dimensions - inches		
Amps	Ferrule	Length
0.5 - 30	13/32	1-1/2

MOL Specifications

Fast-Acting

Voltage Rating: 0.5-15A, 250Vac
20-30A, 125Vac

Amp Rating: 0.5 - 30A

Interrupting Rating:
10kA @ 125Vac 20-30A
35A @ 250Vac 0.5-1A
100A @ 250Vac 1.5-6A
200A @ 250Vac 6.5-10A
750A @ 250Vac 12-15A

Agency Approvals:
(0.5 - 30) UL Listed, File E162443
(0.5 - 30) CSA Cert., LR700489

Benefits:

- Compact dimensions.
- Economical laminated paper tube design.

Applications:

- Supplemental protection for non-inductive control and lighting circuits.

CROSS REFERENCE		
EDISON	GOULD	LITTELFUSE
MOL	OTM	BLF



Catalog No. EBS (0.2 - 10A)
0.2 - 5A 600Vac or Less
6 - 10A 250Vac or Less
Fast-Acting

Amp Ratings				
EBS				
0.2	0.8	1.8	5	10
0.4	1	2	6	—
0.5	1.5	3	7	—
0.75	1.6	4	8	—

Dimensions - inches		
Amps	Ferrule	Length
0.2 - 10	13/32	1-3/8

EBS Specifications
Fast-Acting

Voltage Rating: 0.2-5A, 600Vac
6-10A, 250Vac

Amp Rating: 0.2 - 10A

Interrupting Rating: 10kA RMS Amps

Agency Approvals:
UL Listed, File E162443
CSA Cert., LR700489

Benefits:

- Compact dimensions.
- Shorter than standard midget dimensions.
- Economical design.

Applications:

- Supplemental protection for non-inductive control and lighting circuits.

Recommended Panel Mount Holders:
Refer to page 149 in this catalog.

CROSS REFERENCE		
EDISON	GOULD	LITTELFUSE
EBS	None	BLS

Average Time-Current Curve

Cat. No. MCL (Amp)

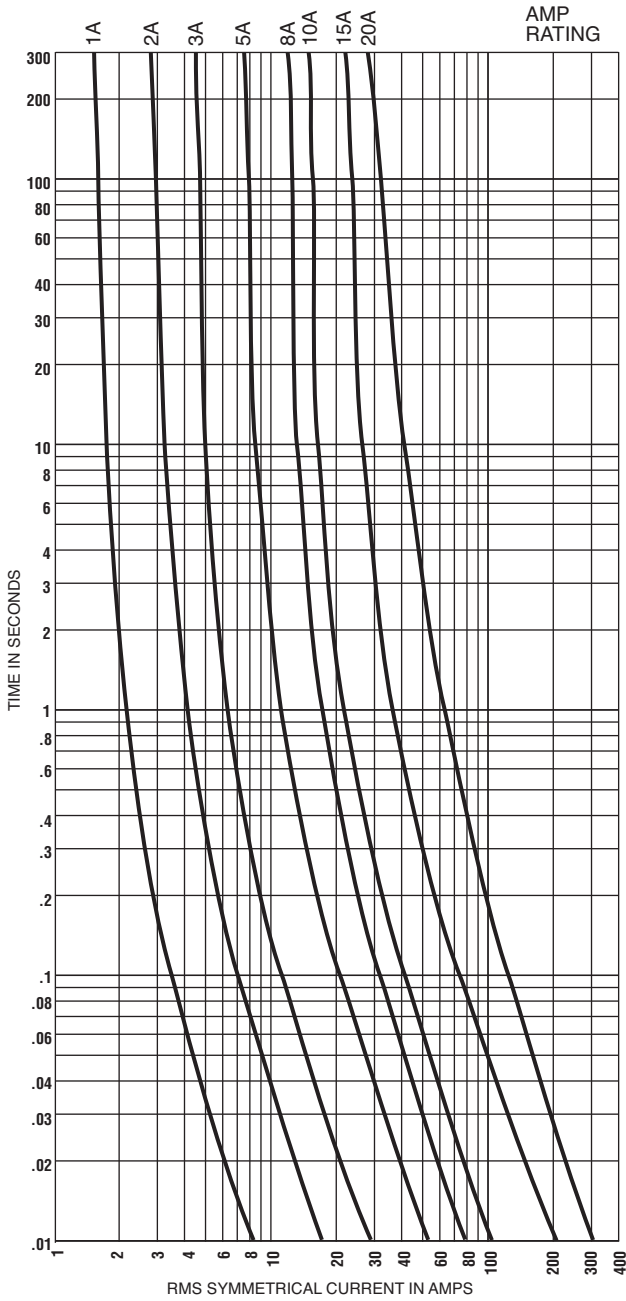

Cat. No. MOL (Amp)

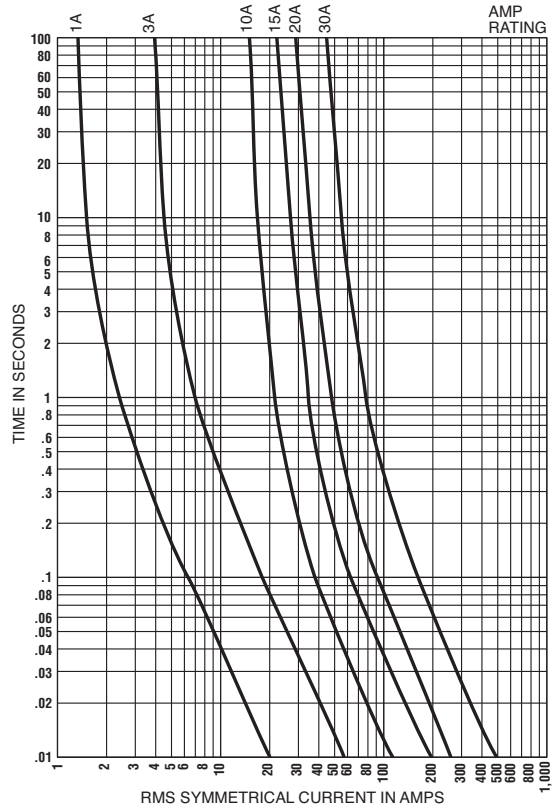

Cat. No. EBS (Amp)

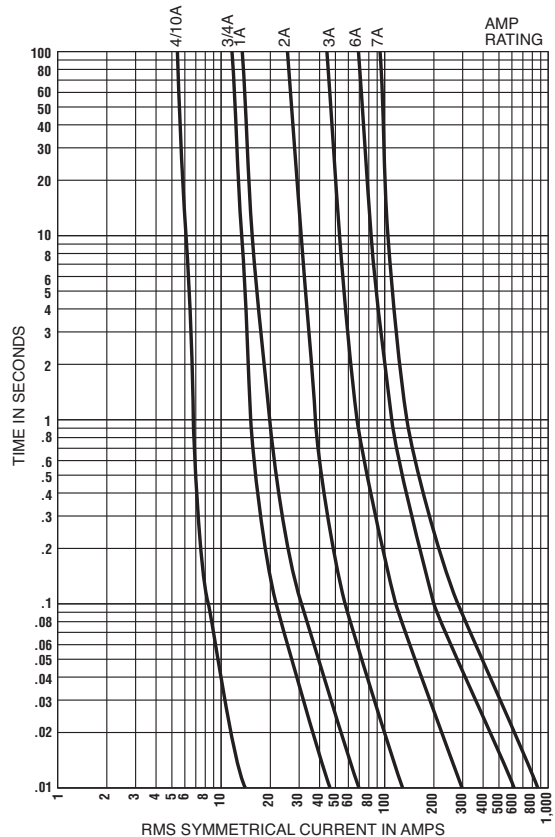



Catalog No. MEQ (0.1 - 30A)
500Vac or Less
Time-Delay

Amp Ratings				
MEQ				
0.1	0.6	2.25	5.6	15
0.125	0.8	2.5	6	20
0.15	1	3	6.25	25
0.2	1.125	3.2	7	30
0.25	1.25	3.5	8	—
0.3	1.5	4	9	—
0.4	1.6	4.5	10	—
0.5	2	5	12	—

Dimensions - inches		
Amps	Ferrule	Length
0.1 - 30	13/32	1-1/2

MEQ Specifications
Time-Delay

Voltage Rating: 500Vac
Amp Rating: 0.1 - 30A
Interrupting Rating: 10kA RMS Amps
Agency Approvals:
 (0.1 - 30) UL Listed, File E162443
 (0.1 - 30) CSA Cert, LR700489

Benefits:

- Compact dimensions.
- Fiber tube construction.
- Time-delay allows harmless inductive surges to pass without needless fuse opening.

Applications:

- Supplemental protection of transformers, solenoids, and other high inrush circuits.
- For motor applications, refer to EDCC.

Recommended Fuse Blocks: Pages 134 and 150. **Recommended Inline Fuse Holders:** Page 146. **Recommended Panel Mount Holders:** Page 149.

CROSS REFERENCE		
EDISON	GOULD	LITTELFUSE
MEQ	ATQ	FLQ



Catalog No. MEN (0.1 - 30A)
250Vac or Less
Time-Delay

Amp Ratings				
MEN				
0.1	0.8	2	4.5	10
0.15	1	2.25	5	12
0.2	1.125	2.5	5.6	15
0.25	1.25	2.8	6	20
0.3	1.4	3	6.25	25
0.4	1.5	3.2	7	30
0.5	1.6	3.5	8	—
0.6	1.8	4	9	—

Dimensions - inches		
Amps	Ferrule	Length
0.1 - 30	13/32	1-1/2

MEN Specifications
Time-Delay

Voltage Rating: 250Vac
Amp Rating: 0.5 - 30A
Interrupting Rating: 10kA RMS Amps @ 125V
Agency Approvals:
 UL Listed, File E162443
 CSA Cert., LR700489

Benefits:

- Compact dimensions.
- Fiber tube construction.
- Dual-element construction allows harmless inductive surges to pass without opening.

Applications:

- Supplemental protection of small motors, transformers, solenoids, and other high inrush power electronic circuits.

CROSS REFERENCE		
EDISON	GOULD	LITTELFUSE
MEN	TRM	FLM



Catalog No. MID (0.1 - 30A)
0.1 - 0.8A 250Vac or Less
1 - 15A 125Vac or Less
20 - 30A 32Vac or Less
Pin Indicating - Time-Delay

Amp Ratings				
MID				
0.1	1	2.25	5.6	15
0.15	1.125	2.5	6	20
0.2	1.25	2.8	6.25	25
0.3	1.4	3	7	30
0.4	1.5	3.2	8	—
0.5	1.6	3.5	9	—
0.6	1.8	4	10	—
0.8	2	5	12	—

Dimensions - inches		
Amps	Ferrule	Length
0.1 - 30	13/32	1-1/2

NOTE: 12-30 A is dual-tube construction.

MID Specifications
Pin Indicating — Time-Delay

Voltage Rating: 0.1 - 0.8A, 250Vac
 1 - 15A, 125Vac
 20 - 30A, 32Vac

Amp Rating: 0.1 - 30A

Interrupting Rating:
 10kA @ 125Vac (1/10-15A)
 1000A @ 32Vac (20-30A)
 35A @ 280Vac (1/10-8/10A)

Agency Approvals:
 UL Listed, File E162443
 CSA Cert., LR700489

Benefits:

- Compact dimensions.
- Silver-plated pin indicates when fuse is opened. Provides positive electrical signal activation.

Applications:

- Supplemental protection for high inrush power electronic circuits.

Recommended Fuse Blocks:
 Refer to page 134 in this catalog.

CROSS REFERENCE		
EDISON	GOULD	LITTELFUSE
MID	GFN	FLA

Average Time-Current Curve

Cat. No. MEQ (Amp)

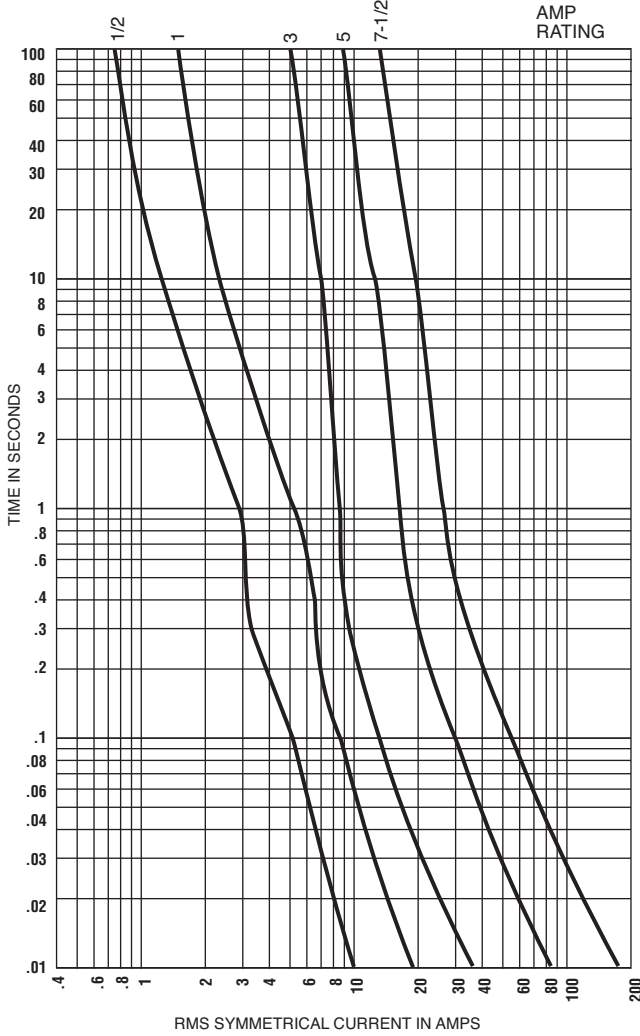

Cat. No. MEN (Amp)

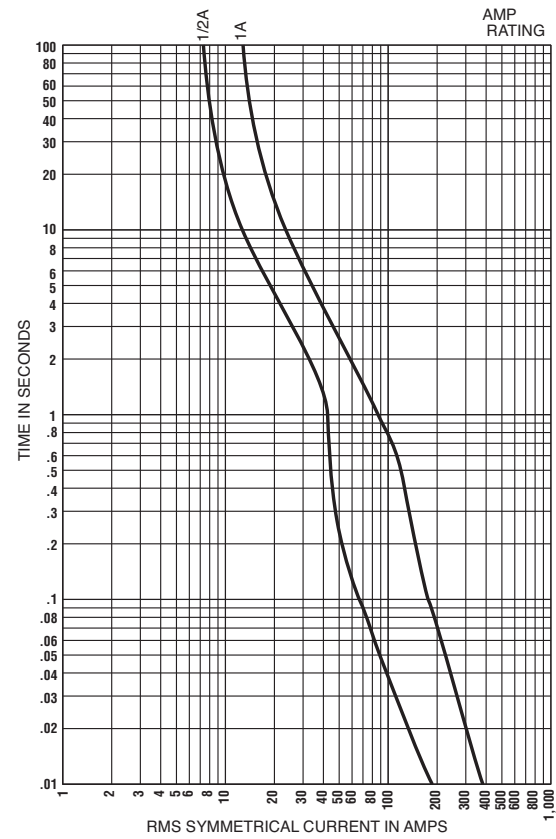

Cat. No. MID (Amp)

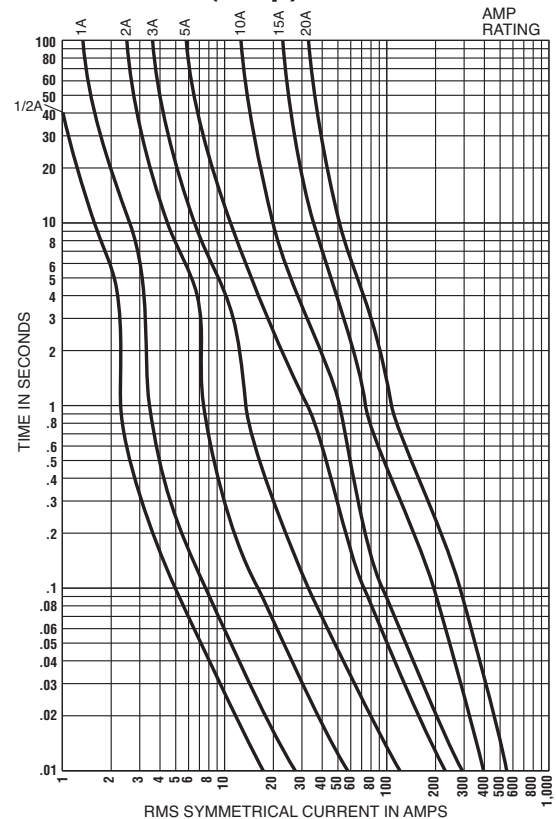



Catalog Number KON (1 - 600A) 250Vac or Less
Catalog Number KOS (1 - 600A) 600Vac or Less

Amp Ratings					
KON 250Vac					
1	7	25	60	125	300
2	8	30	70	150	350
3	10	35	80	175	400
4	12	40	90	200	450
5	15	45	100	225	500
6	20	50	110	250	600
KOS 600Vac					
1	7	25	60	125	300
2	8	30	70	150	350
3	10	35	80	175	400
4	12	40	90	200	450
5	15	45	100	225	500
6	20	50	110	250	600

Self-Certified DC Ratings:

Voltage Rating: KON (1-600A) 250Vdc
KOS (1-30A) 600Vdc
KOS (35-60A) 300Vdc
KOS (70-600A) 600Vdc

Interrupting Rating: 10kA DC @ Rated Voltage

KON/KOS Specifications

“One-Time”, Fast-Acting

Voltage Rating: KON - 250Vac, KOS - 600Vac

Amp Rating: 1 - 600A

Interrupting Rating:

KON 1-60A Class K5 50kA RMS Symmetrical Amps
KON 70-600A Class H 10kA RMS Symmetrical Amps
KOS 1-12A Class H 10kA RMS Symmetrical Amps
KOS 15-60A Class K5 50kA RMS Symmetrical Amps
KOS 70-600A Class H 10kA RMS Symmetrical Amps

Agency Approvals:

UL Listed, Class K5, UL248-9, File E162363
UL Listed, Class H, UL248-6, File E162363
CSA Certified* HRC-K5 per C22.22, No. 248.9, LR700489
CSA Certified HRC-H per C22.22, No. 248.6, LR700489

***NOTE:** KON15 - 60A are not CSA Certified. Refer to PONC for use in CANADA.

Benefits:

- Economical, for general purpose use.

Applications:

- Lighting or heating circuits not subject to high levels of inrush current.
- Circuits having relatively low levels of available short-circuit current.
- For motor applications, refer to Edison ECNR/ECNR.

Recommended Fuse Blocks:

Refer to pages 123 and 126 in this catalog.

Recommended Upgrade:

ECNR/ECNR or LENRK/LESRK.

CROSS REFERENCE		
EDISON	GOULD	LITTELFUSE
KON	OT	NLN
KOS	OTS	NLS

Dimensions - inches

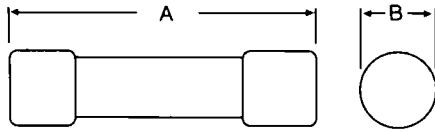

Ferrule Design—1 through 60 Amps

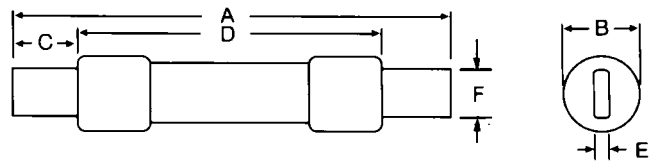

Knife Blade—70 through 600 Amps

Volts and Catalog Number	Amps	Overall	Max. Diameter	Min. Blade Length	Min. Barrel Length	Blade Thickness	Blade Width
		A	B	C	D	E	F
KON 250Vac	1-30	2	9/16	-	-	-	-
	35-60	3	13/16	-	-	-	-
	70-100	5-7/8	1-1/16	1	-	1/8	3/4
	110-200	7-1/8	1-5/8	1-3/8	4-1/8	3/16	1-1/8
	225-400	8-5/8	1-15/16	1-7/8	4-5/8	1/4	1-5/8
KOS 600Vac	450-600	10-3/8	2-5/16	2-1/4	5-3/16	1/4	2
	1-30	5	13/16	-	-	-	-
	35-60	5-1/2	1-1/16	-	-	-	-
	70-100	7-7/8	1-1/16	1	-	1/8	3/4
	110-200	9-5/8	1-5/8	1-3/8	6-1/8	3/16	1-1/8
225-400	11-5/8	2-3/4	1-7/8	7-1/8	1/4	1-5/8	
	450-600	13-3/8	3-1/4	2-1/4	8-3/16	1/4	2

Average Time-Current Curve

Cat. No. KON (Amp) 250Vac

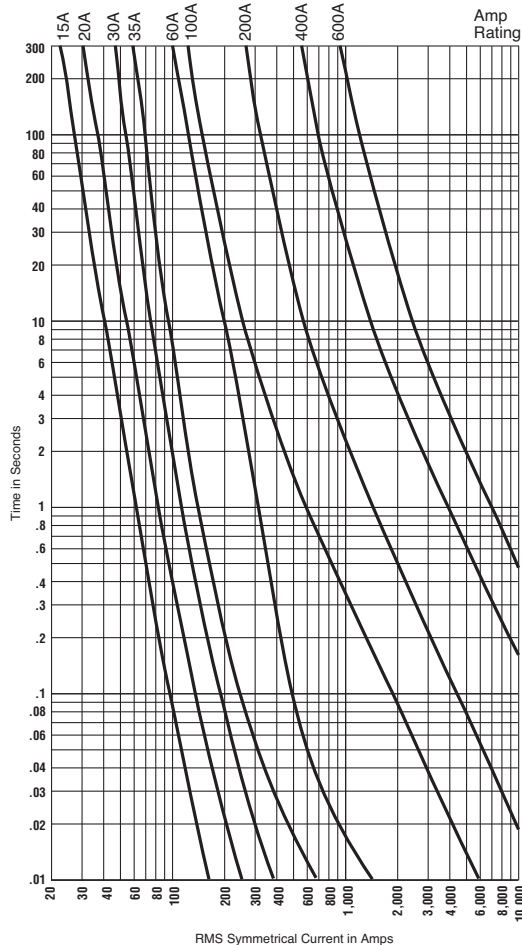

Cat. No. KOS (Amp) 600Vac

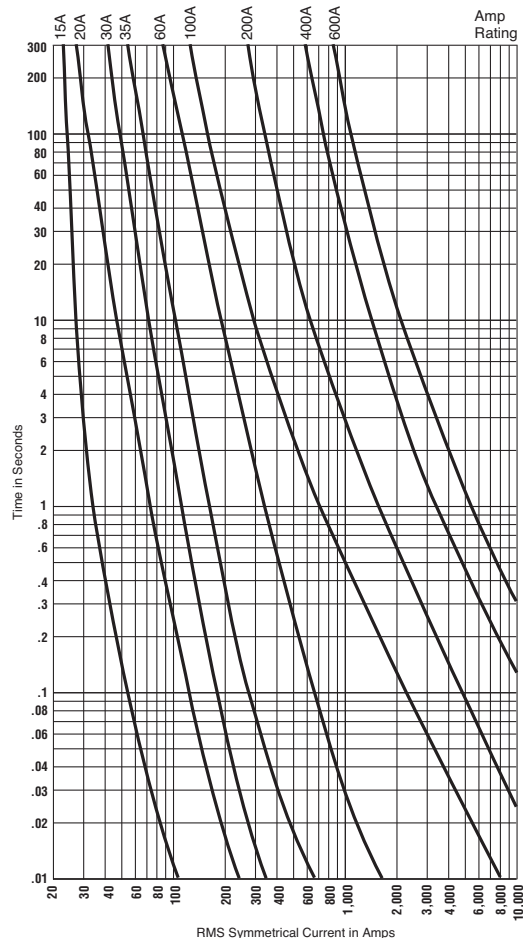



Catalog Number S (1/4 - 30A)
125Vac or Less
Rejection Base
Dual-Element, Time-Delay

Amp Ratings					
S (Amp)					
1/4	1	2	3-1/2	6-1/4	14
3/10	1-1/8	2-1/4	4	7	15
4/10	1-1/4	2-1/2	4-1/2	8	20
1/2	1-4/10	2-8/10	5	9	25
6/10	1-6/10	3	5-6/10	10	30
8/10	1-8/10	3-2/10	6	12	—

S Specifications

Dual-Element, Time-Delay

Voltage Rating: 125Vac

Amp Rating: 1/4 - 30A

Interrupting Rating: 10kA RMS Symmetrical Amps

Agency Approvals:

UL Listed, (0 - 6-1/4A) Guide JFHR, File E56412

(1 - 30A) Guide JEFV, File 12112

CSA Certified per C22.2, No. 248.4

Benefits:

- Size rejection feature helps to prevent overfusing.
- Heavy duty dual-element construction.
- Superior overload and short-circuit protection.

CROSS REFERENCE			
NEW EDISON	OLD EDISON	GOULD	LITTELFUSE
S	3780-amp	None	S00



Catalog Number SL (15 - 30A)
125Vac or Less
Rejection Base
Time-Delay

Amp Ratings			
SL (Amp)			
15	20	25	30

SL Specifications

Time-Delay

Voltage Rating: 125Vac

Amp Rating: 15 - 30A

Interrupting Rating: 10kA RMS Symmetrical Amps

Agency Approvals:

UL Listed, Guide JEFV, File 12112

Benefits:

- Size rejection feature helps to prevent overfusing.
- Time-delay construction withstands light motor loads.
- For upgrade refer to "S" fuse.

CROSS REFERENCE			
NEW EDISON	OLD EDISON	GOULD	LITTELFUSE
SL	3770-amp	GSL	SLO



Catalog Number W (1/2 - 12A)
125Vac or Less
Edison Base
Fast-Acting

Amp Ratings				
W (Amp)				
1/2	2	4	6-1/2	10
1	2-1/2	5	7	12
1-8/10	3	6	8	—

W Specifications

Fast-Acting

Voltage Rating: 125Vac

Amp Rating: 1/2 - 12A

Interrupting Rating: 10kA RMS Symmetrical Amps

Agency Approvals:

UL Listed, Guide JEFV, File E 12112

Benefits:

- General purpose for non-inductive lighting and heating loads.
- Economical.
- Edison base threads into non-rejection fuse receptacles.

Obsoleted W-15 through W-30 plug fuses are replaced with T and TL plug fuses.

Recommended Box Cover Units:

Refer to page 136 in this catalog.

CROSS REFERENCE			
NEW EDISON	OLD EDISON	GOULD	LITTELFUSE
W	3765-amp	GW	W00



Catalog Number SA (1 - 30A)
Rejection Base Fuse Adapter

Adapter Sizes				
SA (Amp)				
1	2	4	8	20
1-1/4	2-1/2	4-1/2	10	30
1-6/10	3-2/10	6-1/4	15	—

Rejection base fuses (Type S and SL) require adapters to be used in standard Edison base sockets. Once installed, rejection base adapters accept only rejection base fuses which prevents the wrong fuse size from being used.

Dual-Element Type S Fuses and Adapters for Small Motor Protection. (Both Motor Running and Short-Circuit Protection)

Fuse Cat. No.	Adapter Cat. No.	Other Accepted Amp Rating
S3/10, S1/2, S8/10 S4/10, S6/10, S1	SA-1	1 amp and smaller
S1-1/8, S1-1-1/4	SA-1-1/4	All smaller
S1-4/10, S1-6/10	SA-1-6/10	All smaller
S1-8/10, S2	SA-2	—
S2-1/4, S2-1/2	SA-2-1/2	1-8/10, 2
S2-8/10, S3-2/10	SA-3-2/10	1-8/10 thru 2-1/2
S3-1/2, S4	SA-4	—
S4-1/2, S5	SA-4-1/2	3-1/2, 4
S5-6/10, S6-1/4	SA-6-1/4	3-1/2 thru 5
S7, S8	SA-8	—
S9, S10	SA-10	7, 8
S12, S14	SA-15	7, 8, 9, 10
Branch Circuit Protection		
S15	SA-15	—
S20	SA-20	—
S25	SA-30	—
S30	SA-30	20, 25, 30

CROSS REFERENCE			
NEW EDISON	OLD EDISON	GOULD	LITTELFUSE
SA	ESA	None	SA0



Catalog Number T (3/10 - 30A)
125Vac or Less
Edison Base
Dual-Element, Time-Delay

Amp Ratings T (Amp)					
3/10	1-1/8	2-1/4	4	7	15
4/10	1-1/4	2-1/2	4-1/2	8	20
1/2	1-4/10	2-8/10	5	9	25
6/10	1-6/10	3	5-6/10	10	30
8/10	1-8/10	3-2/10	6	12	—
1	2	3-1/2	6-1/4	14	—

T Specifications

Dual-Element, Time-Delay

Voltage Rating: 125Vac

Amp Rating: 3/10 - 30A

Interrupting Rating: 10kA RMS Symmetrical Amps

Agency Approvals:

UL Listed, Guide JEFV, File E 12112

Benefits:

- Heavy duty dual-element construction for motor circuits.
- Edison base threads into non-rejection fuse receptacles.
- Superior overload and short-circuit protection.

Recommended Box Cover Units:

Refer to page 136 in this catalog.

CROSS REFERENCE			
NEW EDISON	OLD EDISON	GOULD	LITTELFUSE
T	3785-amp	GT	T00



Catalog Number TL (15 - 30A)
125Vac or Less
Edison Base
Time-Delay

Amp Ratings TL (Amp)			
15	20	25	30

TL Specifications

Time-Delay

Voltage Rating: 125Vac

Amp Rating: 15 - 30A

Interrupting Rating: 10kA RMS Symmetrical Amps

Agency Approvals:

UL Listed, Guide JEFV, File 12112

Benefits:

- Time-delay construction withstands light motor loads.
- Edison base threads into non-rejection fuse receptacles.
- For upgrade refer to "T" fuse.

Recommended Box Cover Units:

Refer to page 136 in this catalog.

CROSS REFERENCE			
NEW EDISON	OLD EDISON	GOULD	LITTELFUSE
TL	3740-amp	GTL	TLO



Catalog Number TC (15 - 30A)
125 Volts AC or Less
Edison Base
Dual-Element, Time-Delay

Catalog Number P (15 - 30A)
125 Volts AC or Less
Edison Base
Dual-Element, One-Time

Amp Ratings			
TC (Amp)			
15	20	25	30

Amp Ratings			
P (Amp)			
15	20	25	30

TC Specifications

Dual-Element, Time-Delay

Voltage Rating: 125Vac

Amp Rating: 15 - 30A

Agency Information:

CSA Certified (Class 1423-01, File # 53787)

Benefits:

- "D" rating for Canadian applications.
- Heavy Duty TC fuses are industrial strength products, featuring Bussmann's exclusive Dual-Element construction.
- This spring loaded design provides superior short-circuit and overload protection.
- The TC fuses have more time-delay than the medium duty fuses in order to better protect industrial motors and optical residential circuits.

Recommended Box Cover Units:

Refer to page 136 in this catalog.

CROSS REFERENCE			
NEW EDISON	OLD EDISON	GOULD	LITTELFUSE
T	3785-amp	GT	TOO

P Specifications

Dual-Element, One-Time

Voltage Rating: 125Vac

Amp Rating: 15 - 30A

Benefits:

- For non-inductive loads.
- Edison base threads into non-rejection fuse receptacles.

Recommended Box Cover Units:

Refer to page 136 in this catalog.

5 x 20mm — IEC Standards



Cat. No. S501 (GDA)* (50mA-10A)
S501-V (GDA-V)* (axial leads)

Specifications

Description: Fast-acting, high-breaking capacity fuse.

Construction: Ceramic tube, nickel-plated brass endcaps.

Ratings:

Volts — 250Vac (or less)

Amps — 50mA-10A**

IR — 1500A @ 250Vac

Agency Information: CE, cURus, SEMKO, VDE, IMQ, CCC, CSA, BSI.

Not all approvals apply to all ratings.

Features and Benefits

- Fast-acting for maximum protection.
- High break capacity for use in higher fault energy electronic circuitry.
- Conforming to IEC standards.

Typical Applications

- Electronic Circuits

Catalog Numbers (Amps)

Catalog Numbers	I ² t	Typical Voltage Drop (mV)
S501-50-R	0.0017	9000
S501-63-R	0.0005	3300
S501-80-R	0.0011	2600
S501-100-R	0.0018	2300
S501-125-R	0.0037	1900
S501-160-R	0.008	1600
S501-200-R	0.020	1350
S501-250-R	0.027	1300
S501-315-R	0.010	1400
S501-400-R	0.018	1200
S501-500-R	0.038	1050
S501-630-R	0.064	1200
S501-800-R	0.097	490
S501-1-R	0.146	330
S501-1.25-R	0.313	297
S501-1.6-R	0.748	239
S501-2-R	2.0	205
S501-2.5-R	3.9	190
S501-3.15-R	8.1	160
S501-4-R	14	160
S501-5-R	25	155
S501-6.3-R	48	150
S501-8-R	N/A	N/A
S501-10-R	N/A	N/A

Options

Axial leads, put "V" in P/N.

*GDA series is not available in RoHS compliant construction.

**GDA is not available above 6.3A.



Cat. No. S500 (GDB)* (32mA-10A)
S500-V (GDB-V)* (axial leads)

Specifications

Description: Fast-acting, low-breaking capacity fuse.

Construction: Glass tube, nickel-plated brass endcaps.

Ratings:

Volts — 250Vac (or less)

Amps — 32mA-10A

IR — See catalog table

Agency Information: CE, cURus, CSA, SEMKO, VDE, BSI, IMQ, CCC.

Not all approvals apply to all ratings.

Features and Benefits

- Fast-acting for maximum protection, conforms to IEC standards.

Typical Applications

- Electronic Circuits

Catalog Numbers (Amps)

Catalog Numbers	IR (Amps)	I ² t	Max Voltage Drop (mV)
S500-32-R	35	0.000047	3200
S500-40-R	35	0.00011	2500
S500-50-R	35	0.00020	2400
S500-63-R	35	0.00057	2000
S500-80-R	35	0.0012	1200
S500-100-R	35	0.003	1100
S500-125-R	35	0.005	1000
S500-160-R	35	0.008	2000
S500-200-R	35	0.016	1700
S500-250-R	35	0.028	1400
S500-315-R	35	0.058	1300
S500-400-R	35	0.018	1100
S500-500-R	35	0.018	220
S500-630-R	35	0.035	220
S500-800-R	35	0.067	190
S500-1-R	35	0.60	200
S500-1.25-R	35	0.84	200
S500-1.6-R	35	1.6	190
S500-2-R	35	4.2	150
S500-2.5-R	35	6.1	150
S500-3.15-R	35	13	130
S500-4-R	40	22	130
S500-5-R	50	42	120
S500-6.3-R	63	69	120
S500-8-R	80	—	120
S500-10-R	100	—	120

Options

Axial leads, put "V" in P/N,

*GDB series is not available in RoHS compliant construction.



Cat. No. S506 (GDC)*
S506-V (GDC-V)* (axial leads)

Specifications

Description: Time-delay, low-breaking capacity fuse.

Construction: Glass tube, nickel-plated brass endcaps.

Ratings:

Volts — 250Vac (or less)

Amps — 32mA-15A**

IR — 35A @ 250Vac

Agency Information: UR, CSA, cURus, SEMKO, VDE, BSI, IMQ, MITI/JET, CCC.

Not all approvals apply to all ratings.

Features and Benefits

- Time-delay compatibility for inductive circuits.
- Conforming to IEC standards.

Typical Applications

- Electronic Circuits

Catalog Numbers (Amps)

Catalog Numbers	Typical I ² t	Max Voltage Drop (mV)
S506-32-R	0.0051	1050
S506-40-R	0.0072	920
S506-50-R	0.0095	800
S506-63-R	0.021	760
S506-80-R	0.038	580
S506-100-R	0.045	490
S506-125-R	0.063	390
S506-160-R	0.093	320
S506-200-R	0.114	340
S506-250-R	0.265	270
S506-315-R	0.621	250
S506-400-R	0.872	210
S506-500-R	0.827	140
S506-630-R	1.33	150
S506-800-R	2.78	75
S506-1-R	6.45	87.5
S506-1.25-R	10.05	86
S506-1.6-R	21.7	82
S506-2-R	31.6	77
S506-2.5-R	59.4	72.5
S506-3.15-R	96.4	68.5
S506-4-R	71.8	67
S506-5-R	142.5	60.5
S506-6.3-R	237.6	54
S506-8-R	255.8	55
S506-10-R	450	54
S506-12.5-R	1019.5	45
S506-15-R	1091.7	65.5

Options

Axial leads, put "V" in P/N.

*GDC series is not available in RoHS compliant construction.

**GDC is not available above 6.3A.

5 x 20mm — N. American Standards



Cat. No. GMA (63mA-15A)

GMA-V (axial leads)

Specifications

Description: Fast-acting fuse

Construction: Glass tube, nickel-plated brass endcaps.

Agency Information: CE, Std. 248-14, UL Listed Guide JDYX, File E19180, 0-6A, UL Recognized, Guide JDYX2, File E19180, 7-15A, CSA Certified, Class 1422-01, File E65063, 0-6.



Cat. No. GMC (50mA-10A)

GMC-V (axial leads)

Specifications

Description: Medium time-delay fuse.

Construction: Glass tube, nickel-plated brass endcaps.

Agency Information: CE, Std. 248-14, UL Listed Guide JDYX, File E19180, 0-6.3A, UL Recognized, Guide JDYX2, File E19180, 7-8A, CSA Certified, Class 1422-01, File 65063, 0-6.3A.



Cat. No. GMD (125mA-4A)

GMD-V (axial leads)

Specifications

Description: Time-delay fuse.

Construction: Glass tube, nickel-plated brass endcaps.

Agency Information: CE, UL Listed Guide JDYX, File E19180, 125mA-3A, UL Recognized, Guide JDYX2, File E19180, 4A, CSA Certified, Class 1422-01, File 53787, 0-4A, PSE/JET, File 1641-31003-1001, 1.2A-4A.



UL/CSA Fuses
Current Limiting

UL/CSA Fuses
General Purpose

Special Purpose Fuses

Canadian Fuses & Holders

Medium Voltage Fuses

Fuse Blocks, Holders & Misc.

Application Section

Catalog Number (amps)	Rated Voltage (Vac)	Vac IR (amps)	
		250	125
GMA-63-R	250	35	10,000
GMA-100-R		35	10,000
GMA-125-R		35	10,000
GMA-200-R		35	10,000
GMA-250-R		35	10,000
GMA-300-R		35	10,000
GMA-500-R		35	10,000
GMA-600-R		35	10,000
GMA-750-R		35	10,000
GMA-800-R		35	10,000
GMA-1-R		35	10,000
GMA-1.25-R		100	10,000
GMA-1.5-R		100	10,000
GMA-1.6-R		100	10,000
GMA-2-R		100	10,000
GMA-2.5-R	100	10,000	
GMA-3.15-R	125	-	10,000
GMA-3.5-R		-	10,000
GMA-4-R		-	10,000
GMA-5-R		-	10,000
GMA-6-R		-	10,000
GMA-7-R		-	200
GMA-8-R		-	200
GMA-10-R		-	150
GMA-15-R		-	150

Options

Axial leads, put "V" in P/N.

CROSS REFERENCE			
NEW EDISON	OLD EDISON	GOULD	LF
GMA	BMA	GGM	235

Catalog Number (amps)	Rated Voltage (Vac)	Vac IR (amps)		
		250	125	
GMC-63mA	250	35	10,000	
GMC-80mA		35	10,000	
GMC-100mA		35	10,000	
GMC-125mA		35	10,000	
GMC-150mA		35	10,000	
GMC-200mA		35	10,000	
GMC-250mA		35	10,000	
GMC-300mA		35	10,000	
GMC-315mA		35	10,000	
GMC-400mA		35	10,000	
GMC-500-R		35	10,000	
GMC-600-R		35	10,000	
GMC-630-R		35	10,000	
GMC-750-R		35	10,000	
GMC-800-R		35	10,000	
GMC-1-R		35	10,000	
GMC-1.25-R		100	10,000	
GMC-1.5-R		100	10,000	
GMC-1.6-R		100	10,000	
GMC-2-R		100	10,000	
GMC-2.5-R		100	10,000	
GMC-3.15-R		100	10,000	
GMC-3.5-R		125	-	10,000
GMC-4-R			-	10,000
GMC-5-R			-	10,000
GMC-6-R	-		10,000	
GMC-6.3-R	-		200	
GMC-7-R	-		200	
GMC-8-R	-		200	
GMC-10-R	-		200	

Options

Axial leads, put "V" in P/N.

CROSS REFERENCE			
NEW EDISON	OLD EDISON	GOULD	LF
GMC	—	GSC	None

Catalog Number (amps)	Rated Voltage (Vac)	Vac IR (amps)	
		250	125
GMD-125-R	250	35	10,000
GMD-150-R		35	10,000
GMD-200-R		35	10,000
GMD-250-R		35	10,000
GMD-300-R		35	10,000
GMD-315-R		35	10,000
GMD-375-R		35	10,000
GMD-400-R		35	10,000
GMD-500-R		35	10,000
GMD-600-R		35	10,000
GMD-630-R		35	10,000
GMD-750-R		35	10,000
GMD-800-R		35	10,000
GMD-1-R		35	10,000
GMD-1.2-R		100	10,000
GMD-1.25-R		100	10,000
GMD-1.5-R		100	10,000
GMD-1.6-R		100	10,000
GMD-2-R		100	10,000
GMD-2.5-R		100	10,000
GMD-3-R	100	10,000	
GMD-4-R	200	10,000	

Options

Axial leads, put "V" in P/N.

CROSS REFERENCE			
NEW EDISON	OLD EDISON	GOULD	LF
GMD	—	None	239

1/4" x 1 1/4" Fast-Acting Fuses



Cat. No. AGC (1/2-30A)

AGC-V (axial leads)



Specifications

Description: Fast-acting fuse.

Construction: Glass tube with nickel-plated brass endcaps.

Agency Information: CE, Std. 248-14, UL Listed, Guide JDYX, File E19180, 0-10A UL Recognized, Guide JDYX2, File E19180, 15-30A CSA Certification, Class 1422-01, File 53787.

Catalog Number (amps)	Rated Voltage	Vac IR (amps)*	
	AC (Max.)	250	32
AGC-1/20-R	250	35	-
AGC-1/10-R	250	35	-
AGC-1/6-R	250	35	-
AGC-1/4-R	250	35	-
AGC-3/16-R	250	35	-
AGC-1/8-R	250	35	-
AGC-3/32-R	250	35	-
AGC-1/16-R	250	35	-
AGC-3/64-R	250	35	-
AGC-45/100-R	250	35	-
AGC-1/2-R	250	35	-
AGC-3/4-R	250	35	-
AGC-1-R	250	35	-
AGC-1 1/4-R	250	100	-
AGC-1 1/2-R	250	100	-
AGC-2-R	250	100	-
AGC-2 1/4-R	250	100	-
AGC-2 1/2-R	250	100	-
AGC-3-R	250	100	-
AGC-4-R	250	200	-
AGC-5-R	250	200	-
AGC-6-R	250	200	-
AGC-7-R	250	200	-
AGC-8-R	250	200	-
AGC-9-R	250	200	-
AGC-10-R	250	200	-
AGC-15-R	32	-	1000
AGC-20-R	32	-	1000
AGC-25-R	32	-	1000
AGC-30-R	32	-	1000

*Interrupting ratings were measured at 70% - 80% power factor on AC, and at a time constant described in UL 248.

Options

Axial leads, put "V" in P/N.

Recommended Fuse Blocks:

Refer to page 150 in this catalog.

Recommended Panel Mount Holder:

Refer to page 149 in this catalog.

CROSS REFERENCE			
NEW EDISON	OLD EDISON	GOULD	LF
AGC	BGC	GCC	312



Cat. No. ABC (1/4-30A)

ABC-V (axial leads)



Specifications

Description: Fast-acting fuse.

Construction: Ceramic tube with nickel-plated brass endcaps.

Agency Information: CE, Std. 248-14 UL Listed, Guide JDYX File E19180, 0-15A UL Recognized, Guide JDYX2, File E19180, 20-25A CSA Certification, Class 1422-01, File 53787, 0-15A, Class 1422-30, File 53787, 20-25A.

Catalog Number (amps)	Rated Voltage		Vac IR (amps)*	
	Vac (Max.)	Vdc (Max.)	250	125
ABC-1/4-R	250	125	35	10000
ABC-1/2-R	250	125	35	10000
ABC-3/4-R	250	125	35	10000
ABC-1-R	250	125	35	10000
ABC-1 1/2-R	250	125	100	10000
ABC-2-R	250	125	100	10000
ABC-2 1/2-R	250	125	100	10000
ABC-3-R	250	125	100	10000
ABC-4-R	250	125	200	10000
ABC-5-R	250	125	200	10000
ABC-6-R	250	125	200	10000
ABC-7-R	250	125	200	10000
ABC-8-R	250	125	200	10000
ABC-10-R	250	125	200	10000
ABC-12-R	250	125	750	10000
ABC-15-R	250	125	750	10000
ABC-18-R	250	125	400	1000
ABC-20-R	250	125	400	1000
ABC-25-R	125	125	-	1000
ABC-30-R	125	125	-	1000

*Interrupting ratings were measured at 70% - 80% power factor on AC, and at a time constant described in UL 248.
DC interrupting ratings available upon request.

Options

Axial leads, put "V" in P/N.

Recommended Fuse Blocks:

Refer to page 150 in this catalog.

Recommended Panel Mount Holder:

Refer to page 149 in this catalog.

CROSS REFERENCE			
NEW EDISON	OLD EDISON	GOULD	LF
ABC	BBC	GAB	314



Cat. No. GBB (1-30A)

GBB-V (axial leads)



Specifications

Description: Very fast-acting fuse.

Construction: Ceramic cartridge with nickel-plated brass endcaps.

Agency Information:

CE, Std. 248-14, UL Recognized, 1-30, 125Vdc/250Vac, File E56412, Guide JFHR2, CSA Accepted, 1-10, 125Vdc/250Vac, File 53787, Class 1422-01.

Catalog Number (amps)	Voltage Rating		Interrupting Rating (amps)	
	Vac	Vdc	250Vac	125Vac/dc
GBB-1-R	250	125	200	10,000
GBB-1 1/4-R	250	125	200	10,000
GBB-2-R	250	125	200	10,000
GBB-3-R	250	125	200	10,000
GBB-4-R	250	125	200	10,000
GBB-5-R	250	125	200	10,000
GBB-6-R	250	125	200	10,000
GBB-7-R	250	125	200	10,000
GBB-8-R	250	125	200	10,000
GBB-9-R	250	125	200	10,000
GBB-10-R	250	125	200	10,000
GBB-12-R	250	125	200	10,000
GBB-15-R	250	125	200	10,000
GBB-20-R	250	125	200	200
GBB-25-R	125	125	200	200
GBB-30-R	125	125	200	200

Options

Axial leads, put "V" in P/N.

Recommended Fuse Blocks:

Refer to page 150 in this catalog.

Recommended Panel Mount Holder:

Refer to page 149 in this catalog.

CROSS REFERENCE			
NEW EDISON	OLD EDISON	GOULD	LF
GBB	—	None	322

UL/CSA Fuses
Current Limiting

UL/CSA Fuses
General Purpose

Special
Purpose Fuses

Canadian
Fuses & Holders

Medium
Voltage Fuses

Fuse Blocks,
Holders & Misc.

Application
Section

1/4" x 1-1/4" Time-Delay Fuses



Cat. No. MDL (1/16-30A)

MDL-V (axial leads)



Specifications

Description: Time-delay fuse.

Construction: Glass tube with nickel-plated brass endcaps.

Agency Information: CE, UL Listed, Guide JDYX, File E19180, 1/16-8A; CSA Certification Class 1422-01, 1/16-8A; UL Recognized, Guide JDYX2, File E19180, 9-30A; CSA Component Acceptance, Class 142230, 9-30A.

Catalog Number (amps)	Voltage Rating Vac	Vac IR (amps)		
		250	125	32
MDL-1/16-R	250	35	10000	-
MDL-1/8-R	250	35	10000	-
MDL-1/4-R	250	35	10000	-
MDL-3/16-R	250	35	10000	-
MDL-1/2-R	250	35	10000	-
MDL-3/8-R	250	35	10000	-
MDL-1-R	250	35	10000	-
MDL-1 1/4-R	250	100	10000	-
MDL-1 1/2-R	250	100	10000	-
MDL-2-R	250	100	10000	-
MDL-2 1/4-R	250	100	10000	-
MDL-2 1/2-R	250	100	10000	-
MDL-3-R	250	100	10000	-
MDL-4-R	250	200	10000	-
MDL-5-R	250	200	10000	-
MDL-6-R	250	200	10000	-
MDL-7-R	250	200	10000	-
MDL-8-R	250	200	10000	-
MDL-9-R	32	-	-	1000
MDL-10-R	32	-	-	1000
MDL-12-R	32	-	-	1000
MDL-15-R	32	-	-	1000
MDL-20-R	32	-	-	1000
MDL-25*	32	-	-	1000
MDL-30*	32	-	-	1000

¹Interrupting ratings were measured at 70% - 80% power factor on AC, and at a time constant described in UL 198L.
 *MDL-25 & MDL-30 are not available in RoHS compliant construction.

Options

Axial leads, put "V" in P/N.

Recommended Fuse Blocks:
 Refer to page 150 in this catalog.

Recommended Panel Mount Holder:
 Refer to page 149 in this catalog.



Cat. No. MDA (1/8-30A)

MDA-V (axial leads)



Specifications

Description: Time-delay fuse.

Construction: Ceramic tube with nickel-plated brass endcaps.

Agency Information: CE, Std. 248-14, UL Listed, Guide JDYX, File E19180, 0-15A CSA Certification, Class 1422-01, File 53787, 0-15A.

Catalog Number (amps)	Voltage Rating Vac	Vac IR (amps)	
		250	125
MDA-1/8-R	250	35	10000
MDA-1/4-R	250	35	10000
MDA-1/2-R	250	35	10000
MDA-3/4-R	250	35	10000
MDA-1-R	250	35	10000
MDA-1 1/2-R	250	100	10000
MDA-2-R	250	100	10000
MDA-2 1/2-R	250	200	10000
MDA-3-R	250	200	10000
MDA-4-R	250	200	10000
MDA-5-R	250	200	10000
MDA-6-R	250	200	10000
MDA-7-R	250	200	10000
MDA-8-R	250	200	10000
MDA-10-R	250	200	10000
MDA12-R	250	750	10000
MDA-15-R	250	750	10000
MDA-20-R	250	1500	10000
MDA-25A-R	250	1500	10000
MDA-30A-R	250	1500	10000

¹Interrupting ratings were measured at 70% - 80% power factor on AC, and at a time constant described in UL 198L.
 DC ratings available upon request.

Options

Axial leads, put "V" in P/N.

Recommended Fuse Blocks:
 Refer to page 150 in this catalog.

Recommended Panel Mount Holder:
 Refer to page 149 in this catalog.

UL/CSA Fuses Current Limiting
 UL/CSA Fuses General Purpose
 Special Purpose Fuses
 Canadian Fuses & Holders
 Medium Voltage Fuses
 Fuse Blocks, Holders & Misc.
 Application Section

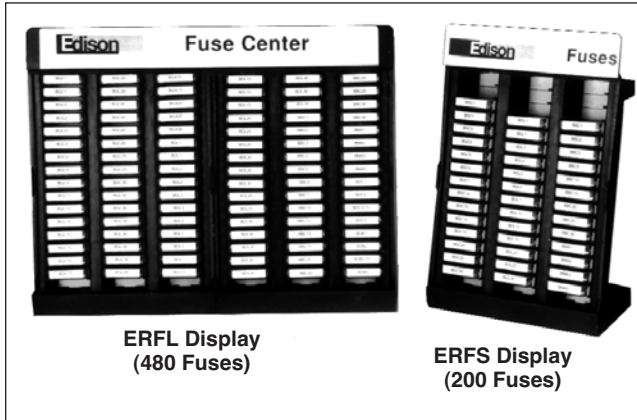

Catalog Number ERFL Display (480 Fuses)
Catalog Number ERFS Display (200 Fuses)

Features:

- Edison display and fuse assortments are compact. They don't waste space. Display and storage area is minimal.
- Slots in the display racks are all labeled for easy inventory and reorder status.
- Display racks are solidly constructed.
- Each assortment has the right fuse mix per actual usage. No dead inventory.

Fuse Assortment consist of the following fuses (packed in 5-in tins) and a FREE Display Stand.

ERFL (Large Assortment)							
2	AGC-1	2	AGX-20	1	MDL-35	1	GMA-3A
2	AGC-2	1	AGX-30	1	ABC-1	1	GMA-5A
2	AGC-3	2	MDL-1	1	ABC-2	1	GDC-1A
1	AGC-4	2	MDL-2	2	ABC-3	1	GDC-2A
2	AGC-5	2	MDL-3	2	ABC-5	1	GDC-3.15A
1	AGC-7	1	MDL-4	1	ABC-7	1	GDC-5A
4	AGC-10	2	MDL-5	2	ABC-10	1	GDB-1A
2	AGC-15	1	MDL-7	2	ABC-15	1	GDB-2A
6	AGC-20	2	MDL-10	2	ABC-20	1	GDB-3.15A
2	AGC-25	2	MDL-15	2	ABC-25	1	GDB-5A
7	AGC-30	6	MDL-20	2	ABC-30	—	
1	AGC-35	2	MDL-25	1	GMA-1A	—	
2	AGX-15	7	MDL-30	1	GMA-2A	—	
ERFS (Small Assortment)							
2	AGC-1	1	AGC-30	1	MDL-25	1	ABC-25
1	AGC-2	2	MDL-1	1	MDL-30	1	ABC-30
1	AGC-3	1	MDL-2	1	ABC-1	1	GMA-1A
2	AGC-5	1	MDL-3	2	ABC-2	1	GMA-2A
1	AGC-7	2	MDL-5	2	ABC-3	1	GMA-3A
3	AGC-10	1	MDL-7	1	ABC-5	1	GMA-5A
1	AGC-15	2	MDL-10	2	ABC-10	—	
1	AGC-20	1	MDL-15	2	ABC-15	—	
1	AGC-25	1	MDL-20	2	ABC-20	—	



CCFSK-45



MFSK-45



RKFSK-39



MKE Merchandising Kits

Purchase the MKE unit as an empty display, or fully stocked (MKE- C).

Features

- Shelves adjust to handle just about any product.
- Heavy-duty casters.
- Product part number bin labels available online.
- A fuse cross-reference guide .
- Flexible header card.

Dimensions

24" wide x 65" tall x 21½" deep. Weight: 48 lbs. when empty.

Construction Market (MKE-C) Contents

Fuse Class	Cat. No.	Description	Fuse Amps	Qty. Each
Class CC	EDCC	600V Time-Delay	10, 15, 20	10
	HCTR	600V Time-Delay	½, 1, 1½, 5, 10	10
	HCLR	600V Fast-Acting	10, 15, 20	10
Class RK5	ECNR	250V Time-Delay	10, 15, 20, 30, 40, 60	10
	ECSR	600V Time-Delay	10, 15, 20, 25, 30, 40, 60	10
Midget	MEN	250V Time-Delay	2, 5, 10	10
	MEQ	500V Time-Delay	5, 10, 15, 20	10
	MCL	600V Fast-Acting	5, 10, 15, 30	10
Fuse Service Kits				
Class RK5	RK5FSK-39	250/600V Fuse Kit	Assortment	1
Midget	MFSK-45	Midget Fuse Kit	Assortment	1
Class CC	CCFSK-45	Class CC Fuse Kit	Assortment	1

Glass Tube Fuses



SFE

Fast-Acting

Physical Size: 1/4" diameter x length as below

Catalog No.	Ampere Rating	Length (In.)
SFE-4	4	5/8
SFE-6	6	3/4
SFE-7-1/2	7-1/2	7/8
SFE-9	9	7/8
SFE-14	14	1-1/16
SFE-20	20	1-1/4
SFE-30	30	1-7/16

Construction: Glass Tube
Voltage Rating: 32V
Agency Approvals:
 UL Listed
 (Guide #FHXT, File #AU169)

CROSS REFERENCE			
NEW EDISON	OLD EDISON	GOULD	LF
SFE	—	—	307

Blade Fuses

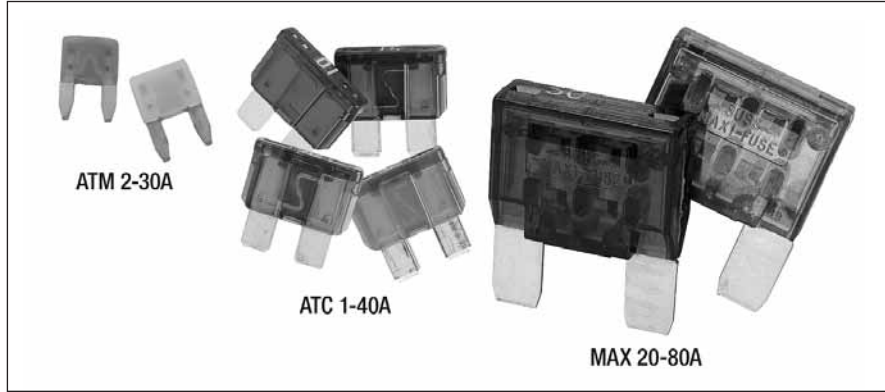

Specifications

Description: Fast-acting blade fuse.

Construction: Plastic housing with zinc fuse element. Zinc ATM blades are silver-plated.

Ratings:

- Volts — 32Vdc
- Amps — 2-30A (ATM)
- 1-40A (ATC)
- 20-80A (MAX)
- IR — 1kA

Features and Benefits

- Color coded for easy identification of fuse ratings

Typical Applications

- Automotive

Catalog Numbers (Amps)

Cat. No. ATM (2-30A)

Catalog Numbers (Amps)

Catalog Numbers	Color Code
ATM-2	Gray
ATM-3	Violet
ATM-4	Pink
ATM-5	Tan
ATM-7 1/2	Brown
ATM-10	Red
ATM-15	Blue
ATM-20	Yellow
ATM-25	Clear
ATM-30	Green

CROSS REFERENCE			
NEW EDISON	OLD EDISON	FERRAZ	LF
ATM	—	AF2	MIN

Cat. No. ATC (1-40A)

Agency Information: UL Recognized, (3-40A) (Guide JFHR2, File E56412), SAE Standard J1284.

Catalog Numbers (Amps)

Catalog Numbers	Color Code
ATC-1	Black
ATC-2	Gray
ATC-3	Violet
ATC-4	Pink
ATC-5	Tan
ATC-7 1/2	Brown
ATC-10	Red
ATC-15	Blue
ATC-20	Yellow
ATC-25	Clear
ATC-30	Green
ATC-40	Orange

CROSS REFERENCE			
NEW EDISON	OLD EDISON	FERRAZ	LF
ATC	BTC	AF	ATO

Cat. No. MAX (20-80A)

Catalog Numbers (Amps)

Catalog Numbers	Color Code
MAX-20	Yellow
MAX-30	Green
MAX-40	Orange
MAX-50	Red
MAX-60	Blue
MAX-70	Tan
MAX-80	Clear

CROSS REFERENCE			
NEW EDISON	OLD EDISON	FERRAZ	LF
MAX	—	AF3	MAX

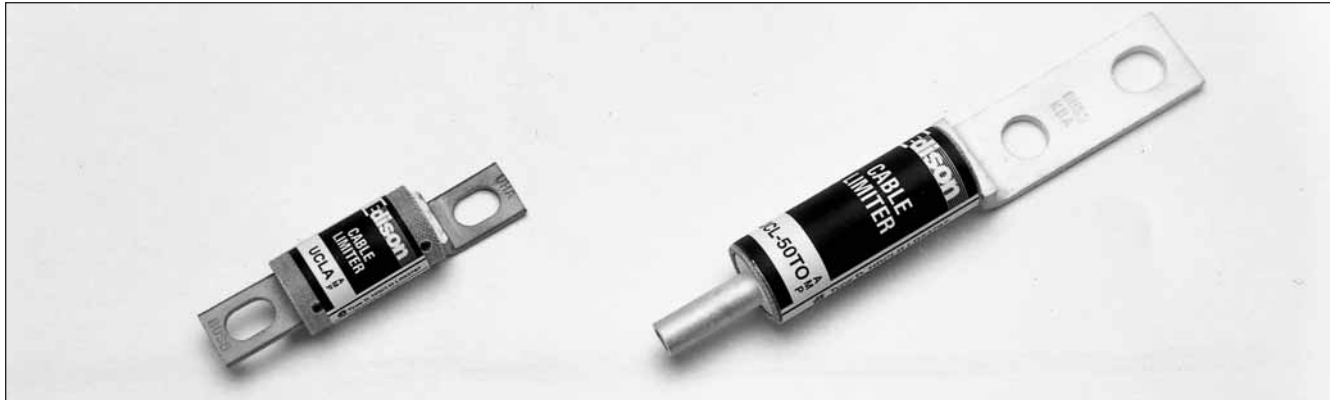

Catalog Number UCL (25XX – 75XX) 600Vac or Less
Catalog Number UCLA 250Vac or Less

Catalog Number*	AC Volts Rating	Copper Cable Size	Cable Terminals Available
UCL25XX ⁽¹⁾	600	250MCM	T = Copper crimp tube O = Bolt-on blade offset from center B = Bolt-on blade, centered
UCL35XX ⁽¹⁾	600	350MCM	
UCL50XX ⁽¹⁾	600	500MCM	
UCL75XX ⁽¹⁾	600	750MCM	
UCLA	250	2/0 or 3/0 ⁽²⁾	Bolt-on blade, one end offset from center

*Contact Edison Customer Satisfaction for availability, limiters not shown, latest data or information.

⁽¹⁾ Choose terminals from "Cable Terminals Available" column to complete catalog number, EXAMPLE: "UCL-25TO" is rated for a "25" 250MCM copper cable and has a "T" tube for crimping and an "O" bolt-on blade, offset from center. Any combination of the three terminals may be selected.

⁽²⁾ A 4/0 aluminum cable may be used with a copper blade-to-aluminum cable connector.

Benefits:

- Cable limiters help to maintain electrical service by minimizing cable damage due to short circuit currents.
- Isolates faulted cable(s) in multiple cables per phase installations.
- Several cable termination types available.

Applications:

- Residential: 250Vac limiters can be used to protect individual service cables tapped from a single transformer.
- Non-Residential: 600Vac cable limiters should be specified to protect parallel service cables in 120/208Vac, 277/480Vac etc. systems.

Cable Limiter Specifications

Voltage Rating: UCL25XX – 75XX, 600Vac
UCLA, 250Vac

Cable Ratings: 250MCM to 750MCM Cu - 600Vac
2/0 or 3/0 Cu - 250Vac
4/0 Al - 250Vac (Cu/Al terminal required)

Interrupting Rating: 600V - 200kA RMS
250V - 100kA RMS

Current Limiting

Agency Approvals:

Self-certified to UL requirements.

CROSS REFERENCE			
VOLTS	EDISON	GOULD	LITTELFUSE
250	UCLA	—	—
250	UCLC	—	—
600	UCL25TO	CP250C3	LFCL250C3
600	UCL25BO	CP250C5	LFCL250C5
600	UCL25TT	CP250C1	LFCL250C1
600	UCL35TO	CP350C3	LFCL350C3
600	UCL35BO	CP350C5	LFCL350C5
600	UCL35TT	CP350C1	LFCL350C1

CROSS REFERENCE			
VOLTS	EDISON	GOULD	LITTELFUSE
600	UCL50TO	CP500C3	LFCL500C3
600	UCL50BO	CP500C5	LFCL500C5
600	UCL50TT	CP500C1	LFCL500C1
600	UCL75TO	CP750C3	LFCL750C3
600	UCL75BO	CP750C5	LFCL750C5
600	UCL75TT	CP750C1	LFCL750C1

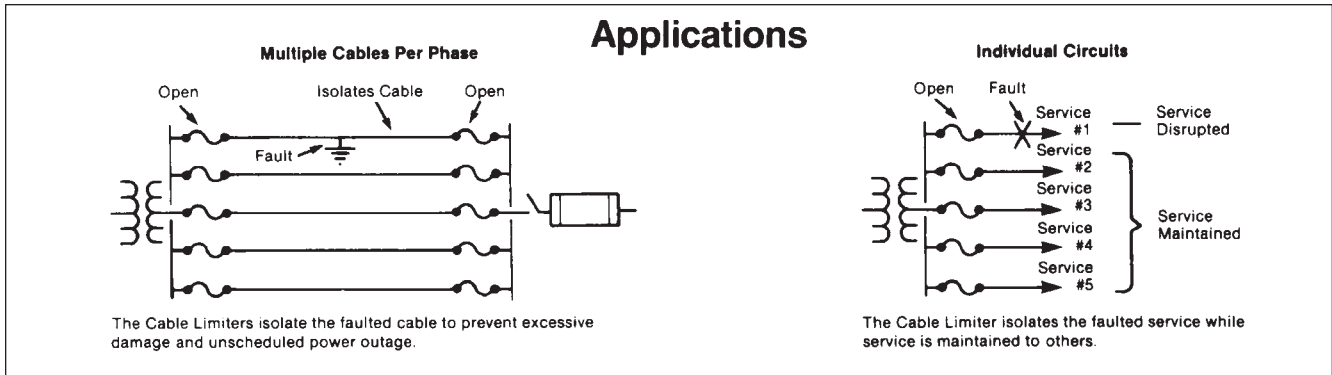

Application of Cable Limiters:

By industry definition, cable limiters do not provide overload protection. Class J and Class L fuses for three or more cables-per-phase applications should be considered if overload protection is a concern. This may also be a desirable consideration for aluminum cable using suitable connectors.

Cable limiters applied in utility networks and building power system main parallel service cables are primarily intended to isolate faults in multiple-cables-per-phase installations. This prevents total power outages until maintenance of faulted cable(s) can be scheduled. During the process of opening under fault conditions to isolate faulted cable(s), limiters current limiting action reduces potential for excess heat damage to unfaulted cables.

For applications having three or more parallel cables-per-phase, cable limiters are installed at each end of each cable. For nonparallel or multiple radial cables, limiters may successfully be applied at the source end of each cable for fault isolation.

When analyzing cable limiter potential applications, it is not unusual to forget that normal and abnormal current through cable limiters is divided just as it is between cables. Selectivity with upstream overcurrent protection devices is seldom of concern. When designing for cable limiter fault isolation to prevent a burn down or unscheduled blackout by one faulted cable, it is desirable to determine the continuous rating load (3 hours or more) that the remaining cables must handle without overheating.

**Dimensions - inches
Cable Limiters 250V or Less AC**

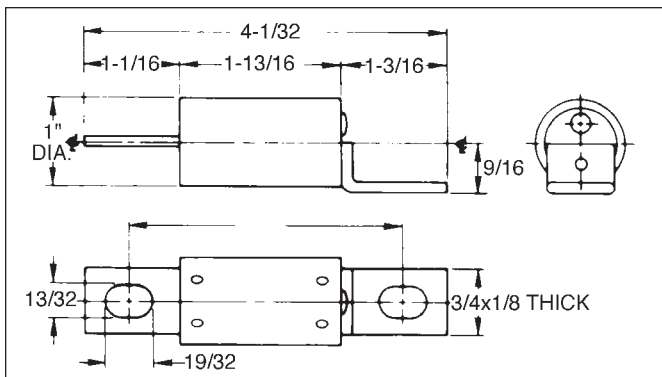

Cat. No. UCLA

Cable Limiters 600V or Less AC

Dimensions are shown in inches.*

Tube-Offset Blade (TO)**

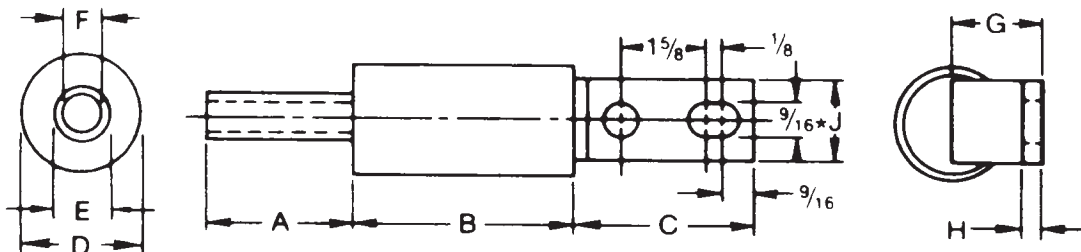

Catalog Number	Copper Cable Size*	A	B	C	D	E	F	G	H	J
UCL25TO	250 MCM	1-7/8	3-5/8	3-3/8	1-7/16	3/4	19/32	31/32	1/4	1-1/8
UCL35TO	350 MCM	2			1-5/8	7/8	45/64	1-1/16		
UCL50TO	500 MCM	2-7/8	1-7/8	1-1/16	53/64	1-3/16				
UCL75TO	750 MCM	3-1/2	3-3/4	3-1/2	2-1/2	1-5/16	1-1/16	1-1/2	2	

Center Blade-Offset Blade (BO)**

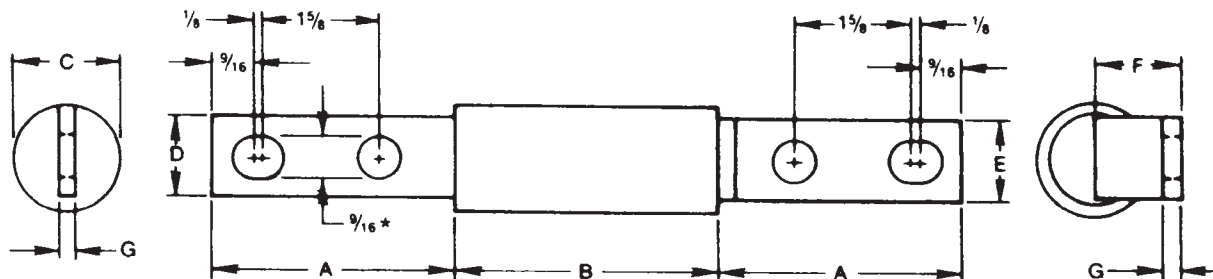

Catalog Number	Copper Cable Size*	A	B	C	D	E	F	G
UCL25BO	250 MCM	3-3/8	3-5/8	1-7/16	1-1/8	1-1/8	31/32	1/4
UCL35BO	350 MCM			1-5/8			1-1/16	
UCL50BO	500 MCM	1-7/8	1-1/2	1-5/8	1-3/16			
UCL75BO	750 MCM	3-1/2	3-3/4	2-1/2	2	2	1-1/2	

Tube-Tube (TT)

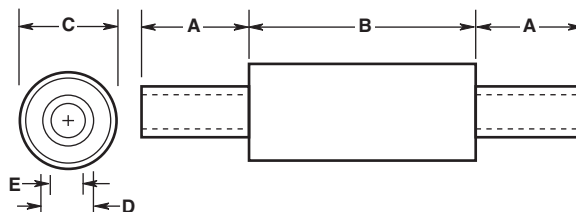

Catalog Number	Copper Cable Size*	A	B	C	D	E
UCL25TT	250 MCM	1-7/8	3-5/8	1-7/16	3/4	19/32
UCL35TT	350 MCM	2		1-5/8	7/8	45/64
UCL50TT	500 MCM	2-7/8	1-7/8	1-1/16	53/64	
UCL75TT	750 MCM	3-1/2	2-7/8	2-1/2	1-5/16	1-1/16

*Limiter terminals are silver plated copper.
**Dimensions of "TT", "OO", "TB", etc., terminals are determined by matching appropriate dimensions shown.

Average Time-Current Curve

Cat. No. UCL-(XXXX)-600Vac

Peak Let-Through Curve
 Edison Copper Cable Limiters

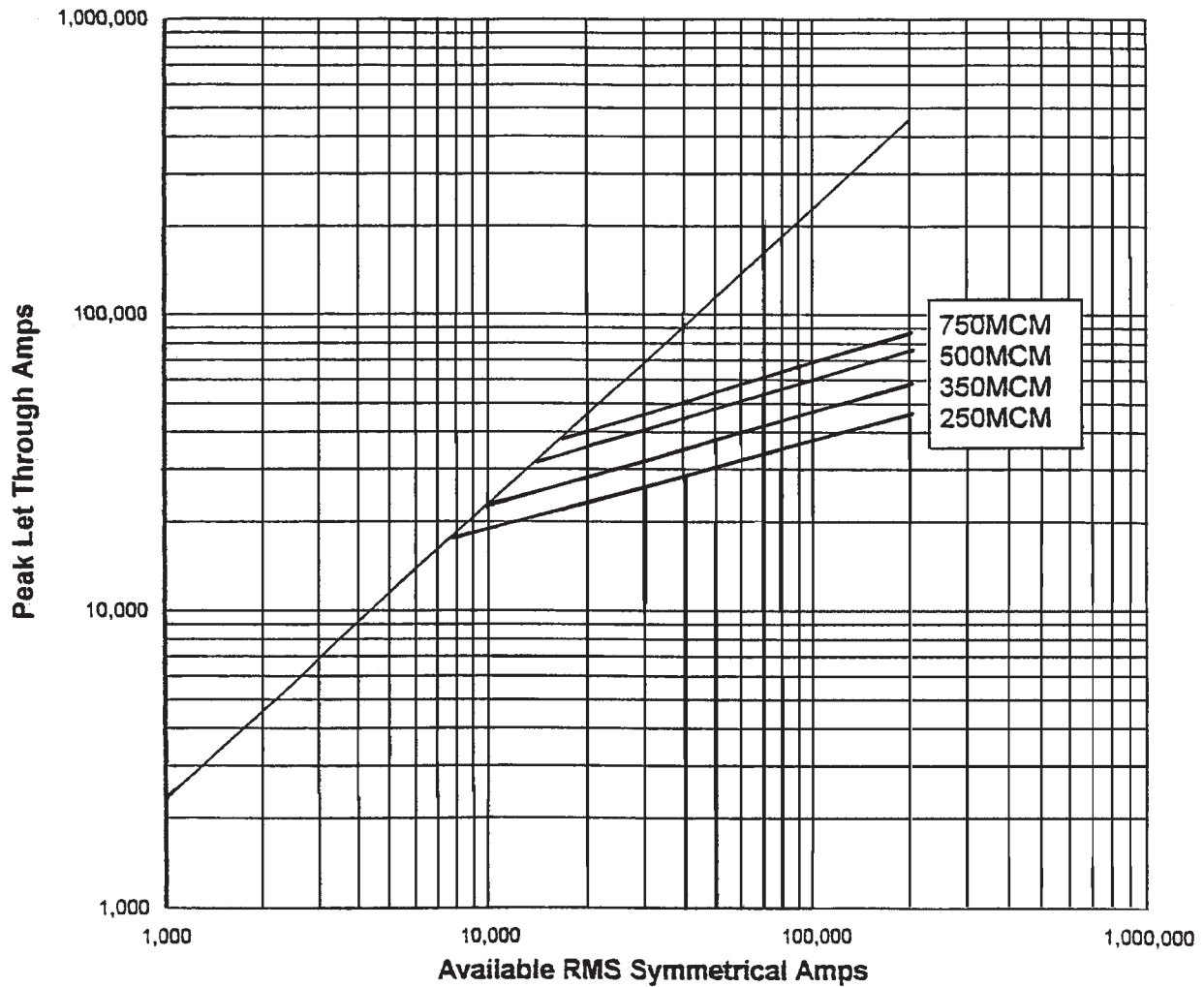

UL/CSA Fuses
 Current Limiting

UL/CSA Fuses
 General Purpose

Special
 Purpose Fuses

Canadian
 Fuses & Holders

Medium
 Voltage Fuses

Fuse Blocks,
 Holders & Misc.

Application
 Section

Average Time-Current Curve

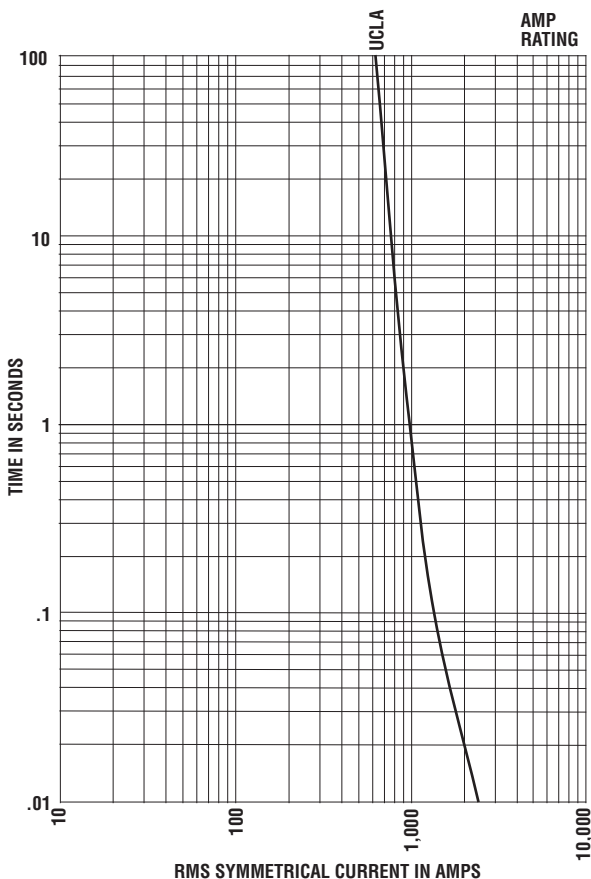

Peak Let-Through Current Curve

Cat. No. UCLA and 250V

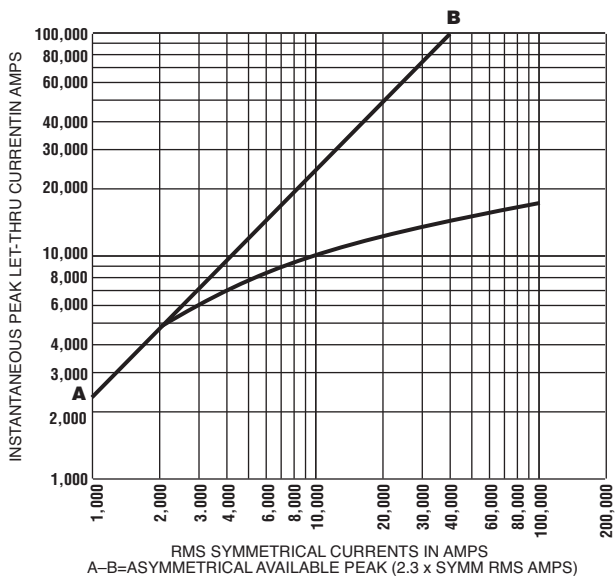

RMS SYMMETRICAL CURRENTS IN AMPS
A-B=ASYMMETRICAL AVAILABLE PEAK (2.3 x SYMM RMS AMPS)

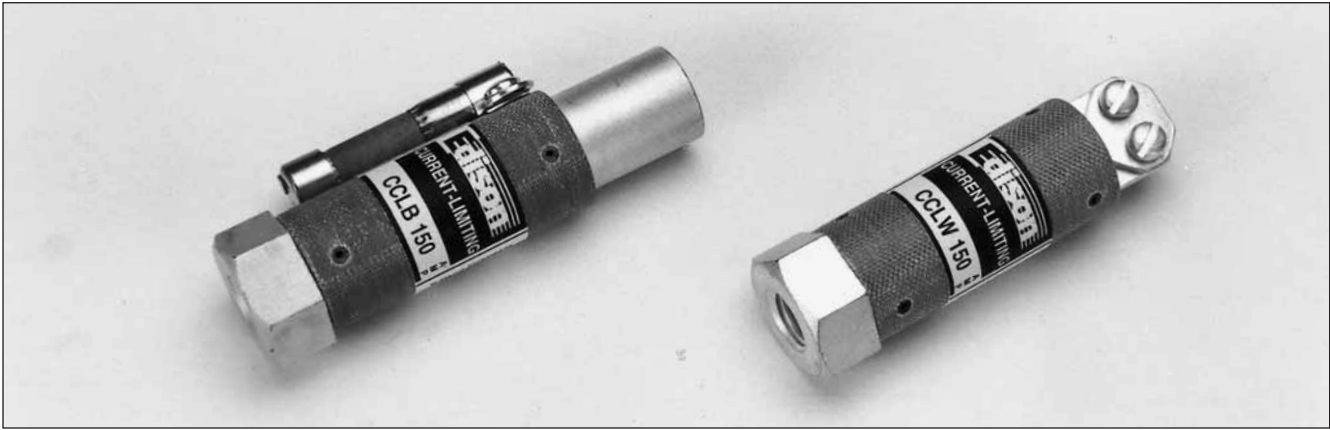

Cat. No. CCLB(Amps)

600Vac or Less
AC Interrupting Rating: 200kA
With open fuse indicator
UL Recognized (80 to 150A) E56412, JFHR2
Non-Time Delay

Amp Ratings CCLB	
80	150
100	200
125	250

Characteristics:

- Stud mount with tapped terminals
- Isolates faulted capacitor
- Size amp rating 150% to 175% of capacitor rated amps
- Maximum quality assurance

Dimensions - inches

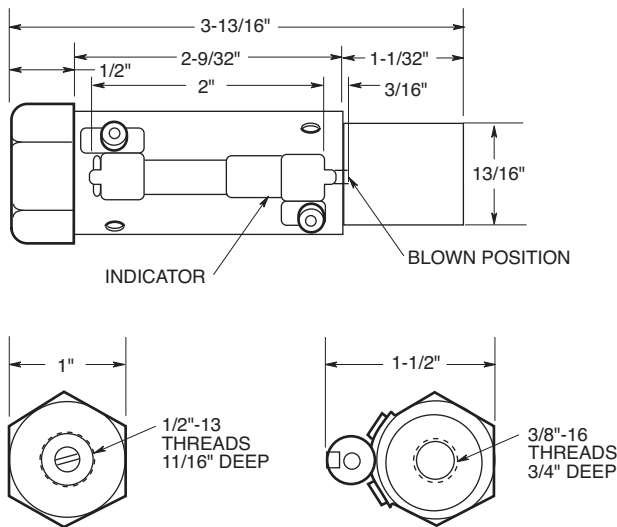

Cat. No. CCLW(Amps)

600Vac or Less
AC Interrupting Rating: 200kA
Without open fuse indicator
UL Recognized 80-150A, (E56412, JFHR2)
Non-Time Delay

Amp Ratings CCLW	
50	150
80	—
100	—

Characteristics:

- Stud mount and pressure plate terminals
- Isolates faulted capacitor
- Size amp rating 150% to 175% of capacitor rated amps
- Maximum quality assurance

Dimensions - inches

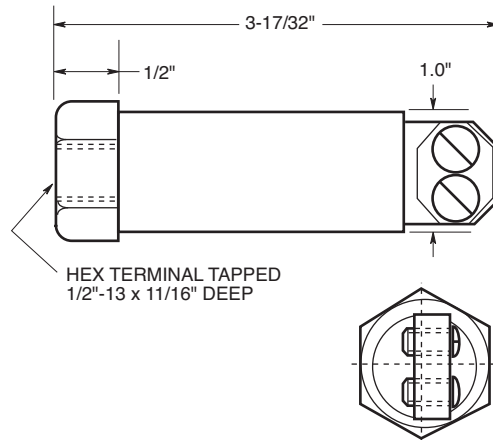

Average Time-Current Curve

Cat. No. CCLB or CCLW (Amp)

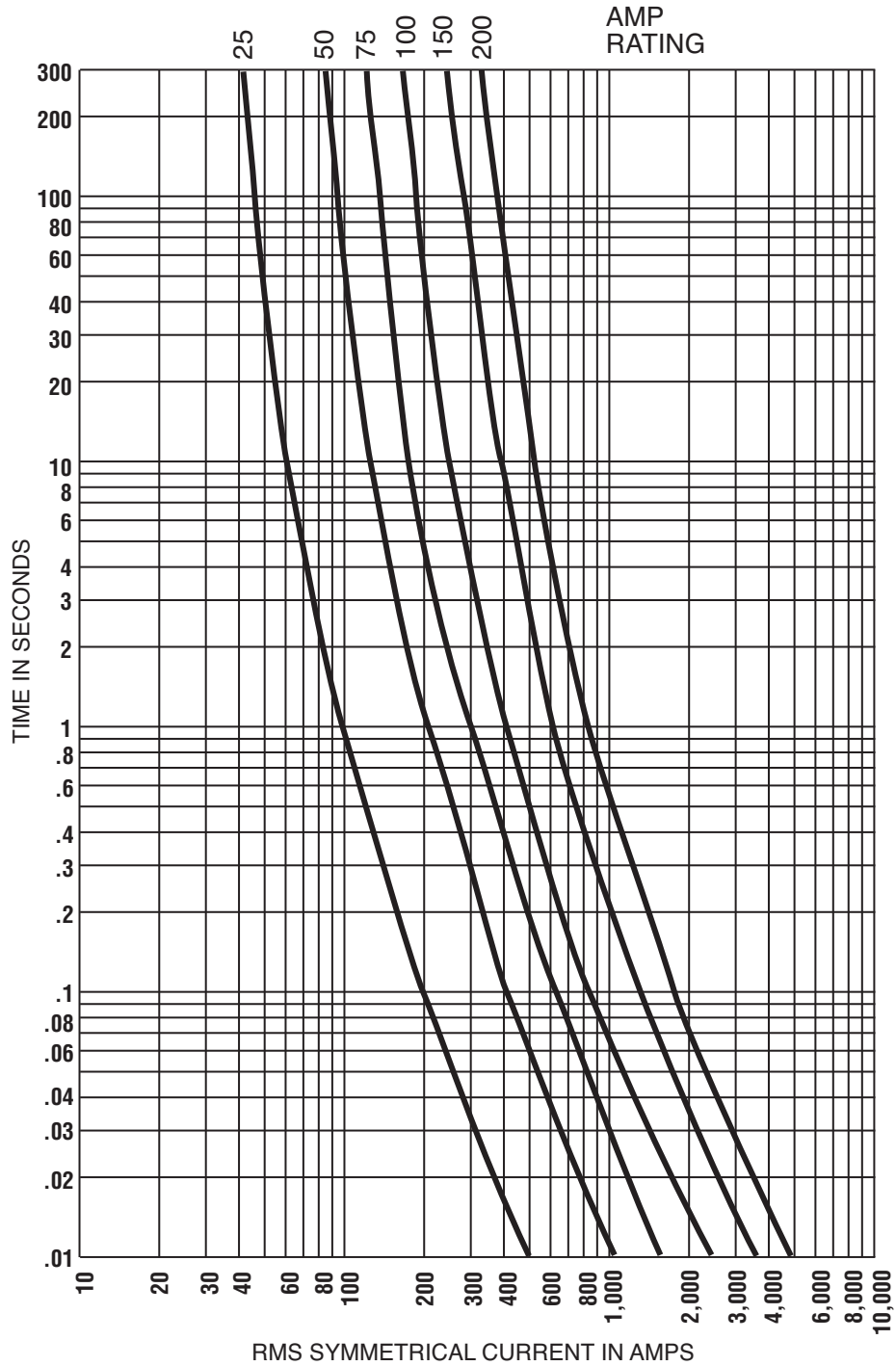

UL/CSA Fuses
Current Limiting

UL/CSA Fuses
General Purpose

Special
Purpose Fuses

Canadian
Fuses & Holders

Medium
Voltage Fuses

Fuse Blocks,
Holders & Misc.

Application
Section

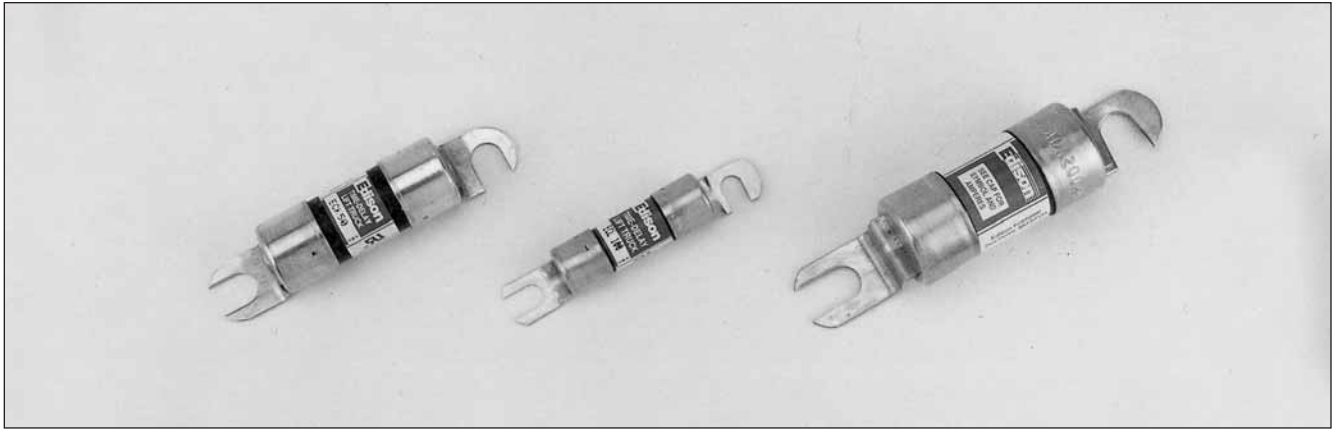

Catalog Number ACK (15 - 400A), ACL (30 - 100A) and ALS (100 - 500A)

Applications:

Popular for protection of DC circuits in fork lift trucks and battery chargers.

Catalog Number	Type	Volts	Amps	Dimensions (Inches)		
				A	B	C
ACK	Time-Delay	130Vdc	15, 20, 25, 30	2.500	0.250	0.563
			35, 40, 50, 60	3.000	0.344	0.813
			70, 75, 80, 100	3.500	0.313	1.063
		72Vdc	120, 140, 150, 175, 200	3.635	0.313	1.063
		48Vdc	225, 250, 300, 400	3.875	0.313	1.063
ACL	Time-Delay	72Vdc	30, 35, 40, 50, 60 80, 100	2.500	0.250	0.563
ALS	Non-Time Delay	130Vdc	100, 120, 140, 150, 175	3.750	0.375	1.063
		36Vdc	200, 225, 250, 300 350, 400, 450, 500			

GROSS REFERENCE			
NEW EDISON	OLD EDISON	GOULD	LITTELFUSE
ACK	ECK	—	CCK
ACL	ECL	—	CCL
ALS	AOK	—	—

Dimensions - inches

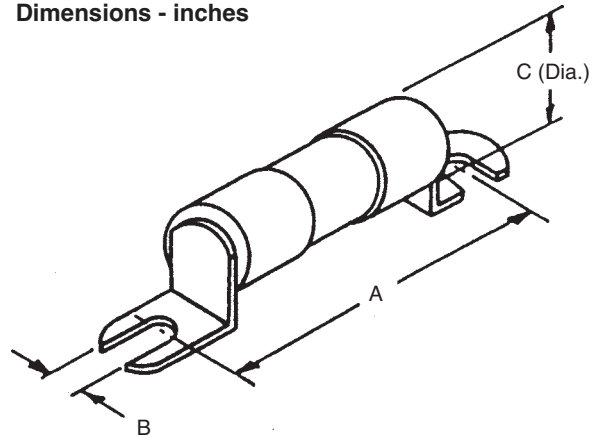

**Catalog Number ANL (35 - 500A)
125Vac or Less**

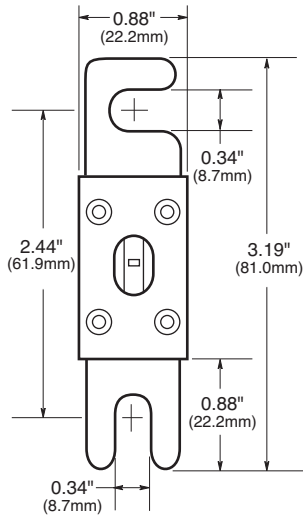
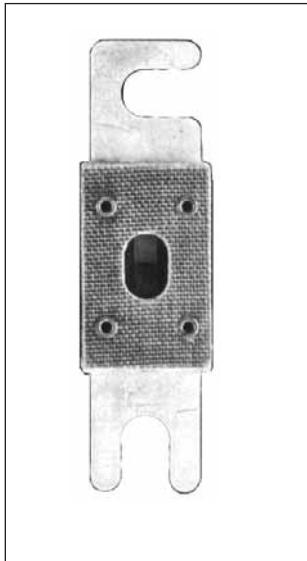

Amp Ratings ANL 125Vac		
35	130	350
40	150	325
50	175	350
60	200	400
80	225	500
100	250	—

ANL Specifications:
Non-Time-Delay

Voltage Rating: 80Vdc, 125Vac

Interrupting Rating: 6kA

Recommended Fuse Block: 4164

Characteristics:

- Isolates faults in equipment systems such as lift trucks and other battery operated systems.
- Silver-plated copper links.
- Link element visible through mica window.

CROSS REFERENCE			
NEW EDISON	OLD EDISON	GOULD	LITTELFUSE
ANL	ENLE	CNL	CNL

Average Time-Current Curve

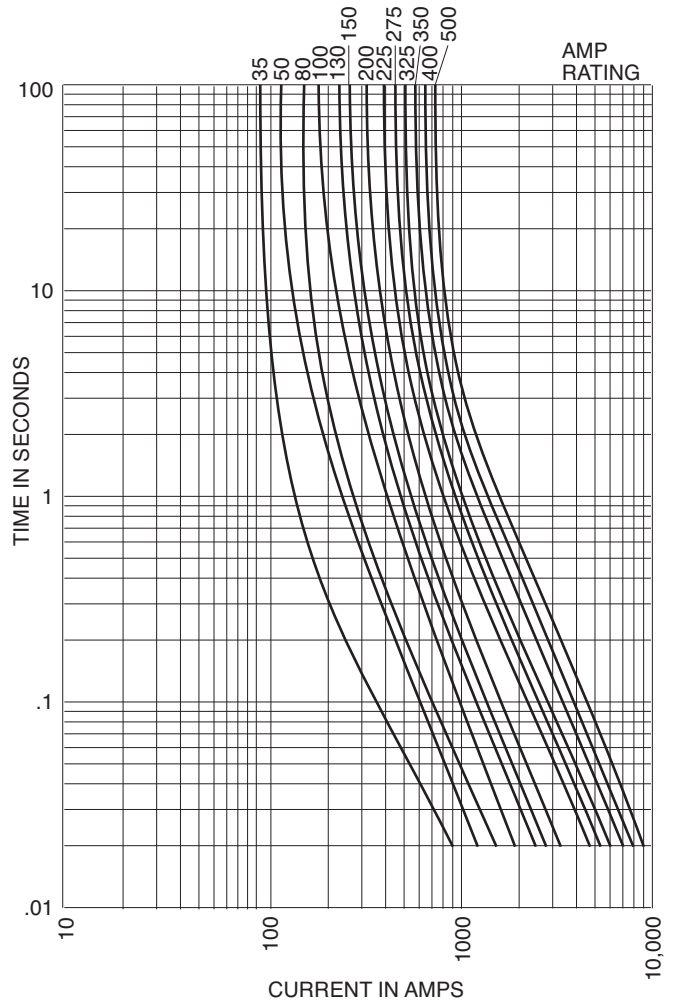

Fuse Block 4164

Holes drilled 0.217" diameter with 0.438" counterbore with 5/16-24 stud.

Dimensions - inches

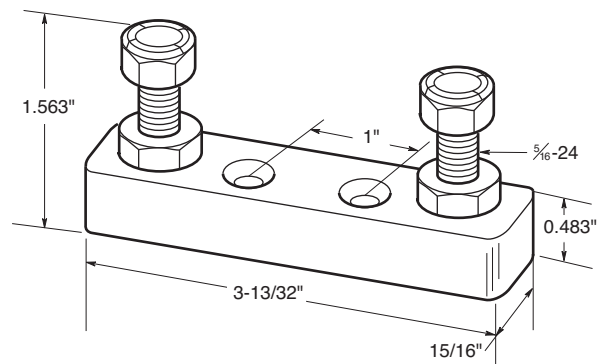

UL/CSA Fuses
Current Limiting

UL/CSA Fuses
General Purpose

Special
Purpose Fuses

Canadian
Fuses & Holders

Medium
Voltage Fuses

Fuse Blocks,
Holders & Misc.

Application
Section

**Catalog Number ANN (35 - 800A)
125Vac or Less**

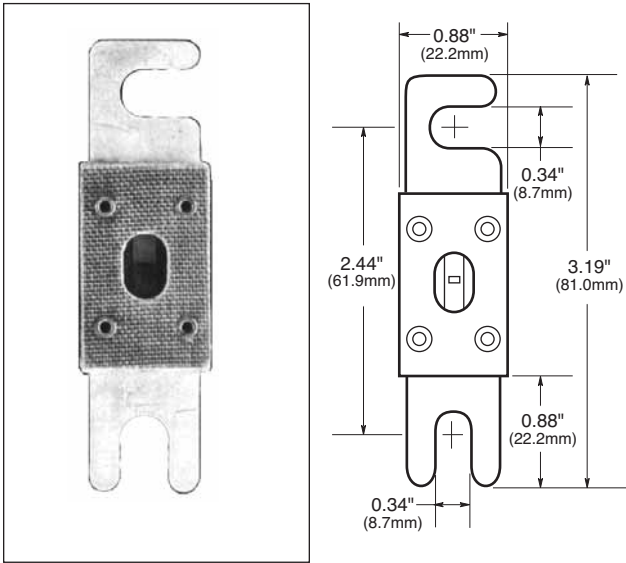

Amp Ratings ANN 125Vac		
35	125	350
40	150	400
50	175	500
60	200	600
80	275	800
90	300	—
100	325	—

ANN Specifications:
Very Fast-Acting

Voltage Rating: 80Vdc, 125Vac

Interrupting Rating: 2.5kA

Recommended Fuse Block: 4164

Characteristics:

- Very fast-acting (high speed of response to short-circuit currents).
- Link element visible through mica window.
- UL Recognized 35-400A (Guide #JFHR2, File #E56412)

CROSS REFERENCE			
NEW EDISON	OLD EDISON	GOULD	LITTELFUSE
ANN	ENNE	CNN	CNN

Average Time-Current Curve

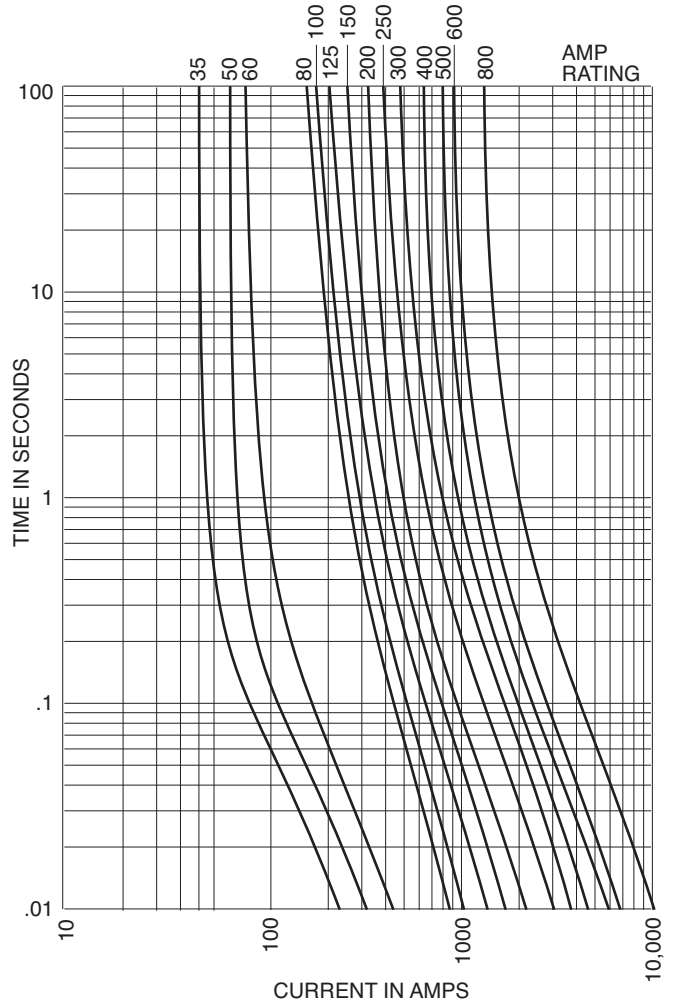

Fuse Block 4164

Holes drilled 0.217" diameter with 0.438" counterbore with 5/16-24 stud.

Dimensions - inches

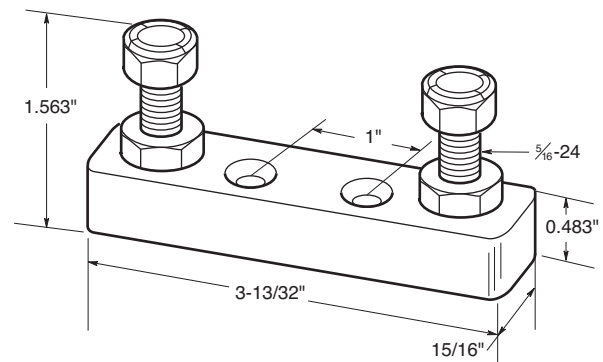



Standard Ratings

Voltages	Catalog Number	Amp Ratings	UL Component Recognition			
			Vac	AC AIR	Vdc	DC AIR
130V	E13S (Amp)	1000 – 3000	130	200,000	130	
150V	E15SF(Amp)	5 – 60	150	200,000	150	
	E15S(Amp)	70 – 1000				
250V	E25SFX(Amp)	5 – 30	250	200,000	250	10,000
	E25S(Amp)	35 – 800			250	10,000
	E25S(Amp)	1000 – 2500			—	—
500V	E50SF(Amp)	5 – 30	500	200,000	500	10,000
	E50S(Amp)	35 – 1600			500	100,000
	E50S(Amp)	900-1200			—	—
600V	E60C(Amp)	0 - 20	600	10,000	100,000	
		25 - 600				
		700 – 1000				
600V	E60SF(Amp)	5 – 30	600	200,000		
		E60S(Amp)				
700V	E70SF(Amp)	5 – 30	700	200,000	700	10,000
	E70S(Amp)	35 – 800			700	10,000
	E70S(Amp)	1000 – 1200			—	—
1000V	E100SF(Amp)	20 – 30	1000	200,000	800	
	E100S(Amp)	40 – 500			800	
	E100S(Amp)	600 – 800			700	

Technical Data

In many cases, the data in this catalog section which includes available ratings, dimensions, time current characteristics and I²t let-through, will enable a suitable choice of fuse to be made. The following notes are a guide to assist fuse selection.

Voltage Rating

The test voltage is equal to the rated voltage. The DC voltage ratings are tested with a time constant of 10ms. For longer time constants the following typical derating factors apply:

Time constant ms	25	40	60
Voltage derating factor	0.85	0.7	0.6

Current Rating

The maximum current carrying capability is at least equal to the current rating, provided that the ambient temperature is less than 30°C, conductor sizes are at least 1mm² per amp, and there is natural convection cooling.

For ambient temperatures higher than 30°C, a derating of 0.5% per °C is recommended. In situations where the air temperature surrounding the fuse is higher than the ambient temperature, i.e. inside a converter cubicle, the derating should be based on the air temperature surrounding the fuses.

In many installations, power semiconductors are force cooled in an air stream. Fuses can be mounted in this air stream and their maximum current carrying capability can then be increased. This increase is up to approximately 20% in an air velocity of 5m/s but higher velocities do not produce any substantial increase in rating.

Power Dissipation

The values of watts loss given are related to full rated current with the correct sizes of conductors and natural cooling.

Time Current Characteristics

Individual time current characteristics are subject to a $\pm 10\%$ tolerance on current and are based on symmetrical sinusoidal 60Hz currents. High speed fuses are designed to clear fault currents associated with pre-arcing times of 30 seconds or less. Dashed lines on time-current characteristic curves represent overload conditions which, should always be avoided.

Permitted Overloads

In many applications, surges occur during the normal duty of equipment and under such permitted overloads, the fuse must not open.

For permitted overloads lasting longer than a few minutes, the fuse current rating should be selected based on the overload current. The current rating of the fuse should exceed the overload current.

For infrequent normal overloads, fuse selection can be made on the basis of an overload curve of not more than 75% of the published time current characteristic.

For highly repetitive overloads, such as in a steel mill thyristor drive, fuse selection should be made on the basis of an overload curve of not more than 60% of the published time current characteristic.

I²t Characteristics

The melting I²t of fuses is independent of voltage and reduces to a minimum value for times less than about 1ms. For longer times, reference should be made to the time current characteristics.

The total I²t values for operating times less than one half-cycle are shown in the data sheets and relate to a fault current of at least 20x rated current, I_n, with a power factor of 15%.

The total I²t values reduce considerably at voltages below the rated voltage since the arc interruption is easier.

Breaking Capacity

In general, high speed fuses perform well at very high fault currents and many products have been successfully tested up to 200kA rms symmetrical. The fuses are essentially for short-circuit protection and therefore in general, only required to clear faults for melting times less than 30 seconds.

Peak Let-Through Current Curves

Short-circuit coordination of power semiconductors is assessed with the use of I²t values. Traditional supplementary peak let-through current curves are also shown in the catalog.

Arc-Voltage Characteristics

Applications using modern power semiconductors are not normally sensitive to the peak arc voltages produced by Edison high speed fuses.

Typical values of arc voltages in relation to the rated fuse voltage, U_n, are:

System Voltage	Arc Voltage of Fuse
U _n	2.0 U _n
0.5 U _n	1.25 U _n
0.2 U _n	0.7 U _n

Example: a 500V Edison high speed fuse used on a 250V system would produce an arc voltage of approximately 625 volts.



Catalog Symbol: JHL
High Speed Fuse

Current-Limiting
Ampere Rating: 1 to 600A
Voltage Rating: 600Vac (or less), 450Vdc (or less)
Interrupting Rating: 200kA RMS Sym., 100kA DC
Agency Information:
UL Listed, Std. 248-8, Class J, Guide JDDZ, File E162363
CSA Certified, C22.2 No. 248.8, Class 1422-02, File 53787

Combine the performance of high speed semiconductor fuses and the convenience of Class J branch circuit fuses in on package.

The new Edison Drive Fuse will provide maximum protection for AC and DC drives and controllers and meet NEC® branch circuit protection requirements.

General Information:

- Easily coordinated with existing and new variable speed drives and electric controllers.
- Standard Class J dimensions allowing the use of readily available fuse blocks, holders, and switches.
- Allows the lowest let-thru energy of any branch circuit overcurrent protective device.

Catalog Numbers (Amps)

JHL1	JHL15	JHL70	JHL225
JHL2	JHL20	JHL80	JHL250
JHL3	JHL25	JHL90	JHL300
JHL4	JHL30	JHL100	JHL350
JHL5	JHL35	JHL110	JHL400
JHL6	JHL40	JHL125	JHL450
JHL8	JHL45	JHL150	JHL500
JHL10	JHL50	JHL175	JHL600
JHL12	JHL60	JHL200	

Time-Current Characteristic Curves—Average Melt

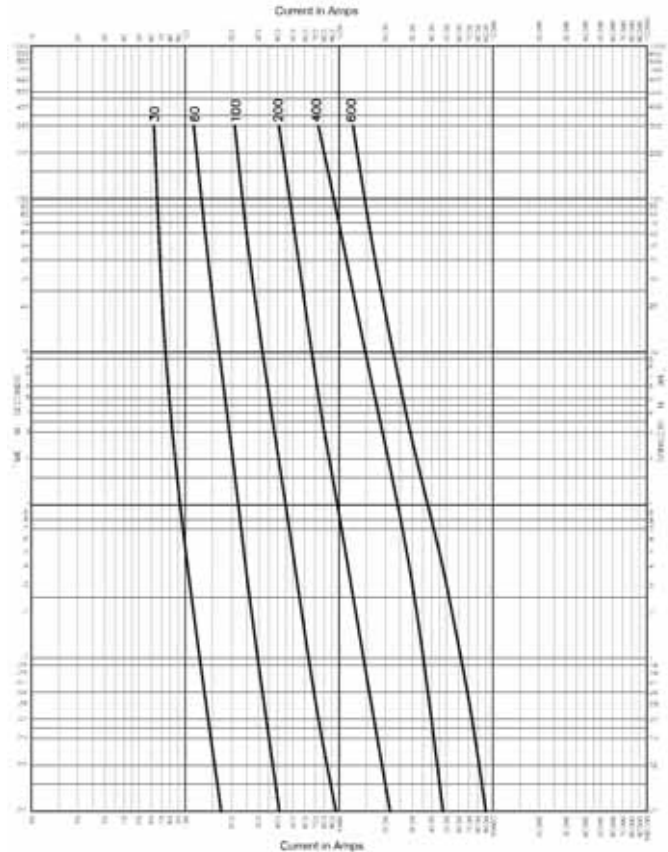

Current Limitation Curves

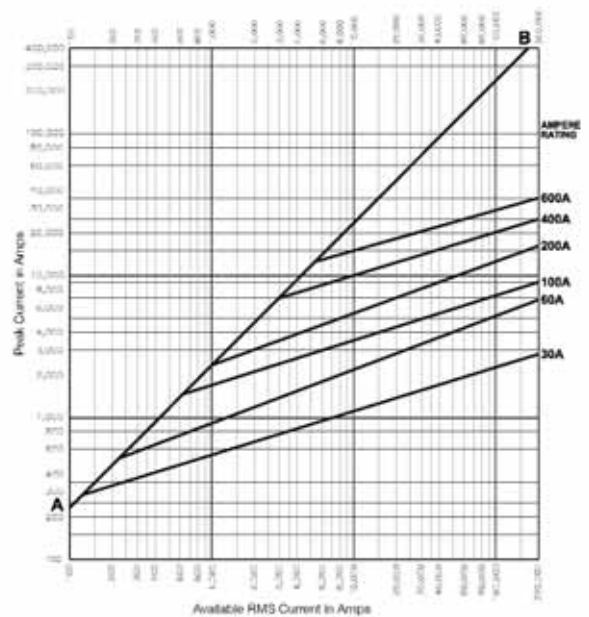

UL/CSA Fuses
Current Limiting

UL/CSA Fuses
General Purpose

Special
Purpose Fuses

Canadian
Fuses & Holders

Medium
Voltage Fuses

Fuse Blocks,
Holders & Misc.

Application
Section

Catalog Number E13S(Amp) 130Vac/130Vdc

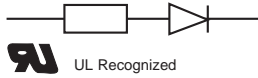

Dimensions - inches

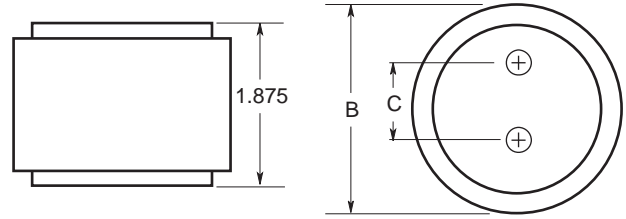

E13S(Amp) Dimensions - inches				
Catalog Numbers	Figure	B	C	Threat Depth
E13S1000HP-2000	1	2.0	1.0	Tapped 3/8" - 24 x 1/2"
E13S2500-3000	1	3.0	1.5	Tapped 1/2" - 20 x 1/2"

Figure 1: 1000 – 3000A Range

E13S(Amp) Electrical Characteristics				
Catalog Numbers	Rated Current RMS Amps	Melting I ² t	Clearing I ² t @ 130V	Watts Loss @ Rated Current
E13S1000HP	1000	170,000	460,000	60
E13S1200	1200	270,000	730,000	70
E13S1500	1500	520,000	1,400,000	78
E13S2000	2000	860,000	2,400,000	108
E13S2500	2500	1,500,000	4,100,000	130
E13S3000	3000	2,100,000	5,700,000	150

NOTE: To cross reference 130V high speed fuses below 1000A, refer to upgraded Edison E15S(Amp) – 150V fuses.

Minimum Melting Curves

E13S1000 – 3000, 130V

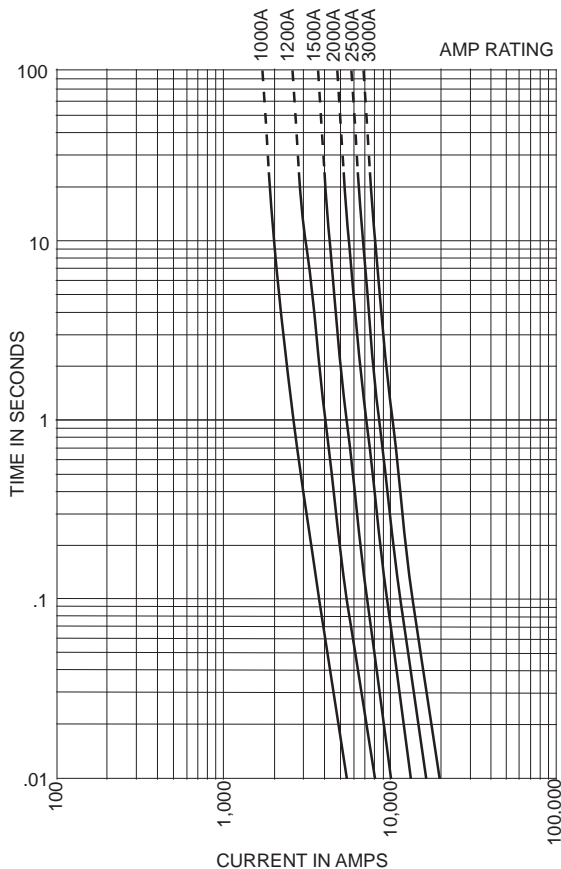

Peak Let-Through Current Curves

E13S1000 – 3000, 130V

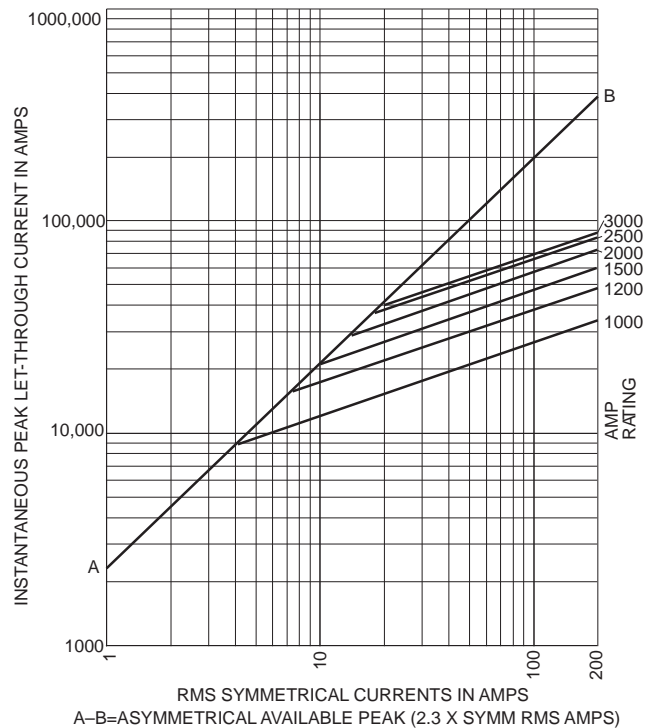

Catalog Number E15SF5 – 60

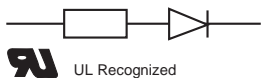

E15SF(Amp) Dimensions - inches (mm)				
Catalog Numbers	Figure	A	B	C
E15SF5 – 30	1	1.500 (38.1)	0.375 (9.5)	0.406 (10.3)
E15SF35 – 60	1	2.000 (50.8)	0.625 (15.9)	0.812 (20.6)

Dimensions - in (mm)

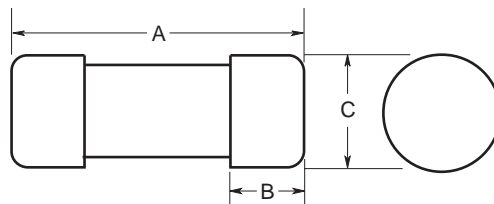

Figure 1: 5 – 60A Range

Catalog Number E15S70 – 1000

E15S(Amp) Dimensions - inches (mm)									
Catalog Numbers	Figure	A	B	C	D	E	F	G	H
E15S70 – 400	2	2.656 (67.5)	2.062 (52.4)	1.156 (29.4)	1.000 (25.4)	0.125 (3.2)	0.750 (19.1)	0.312 (7.9)	0.438 (11.1)
E15S500 – 1000	3	3.500 (88.9)	2.438 (61.9)	1.250 (31.8)	1.500 (38.1)	0.250 (6.4)	1.000 (25.4)	0.406 (10.3)	0.406 (10.3)

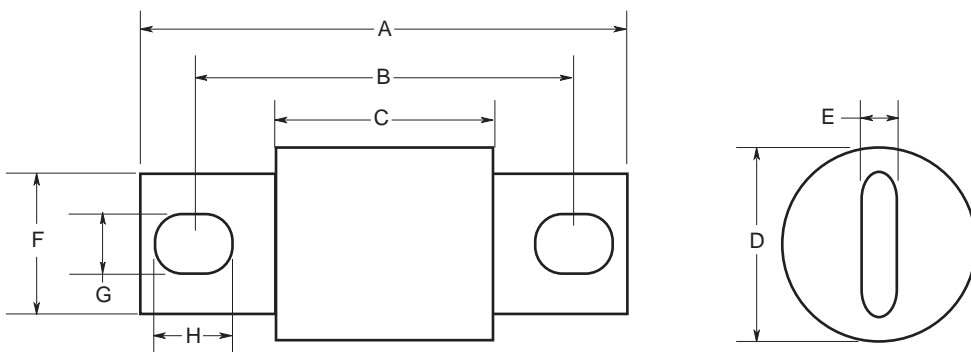

Figure 2: 70 – 400A Range

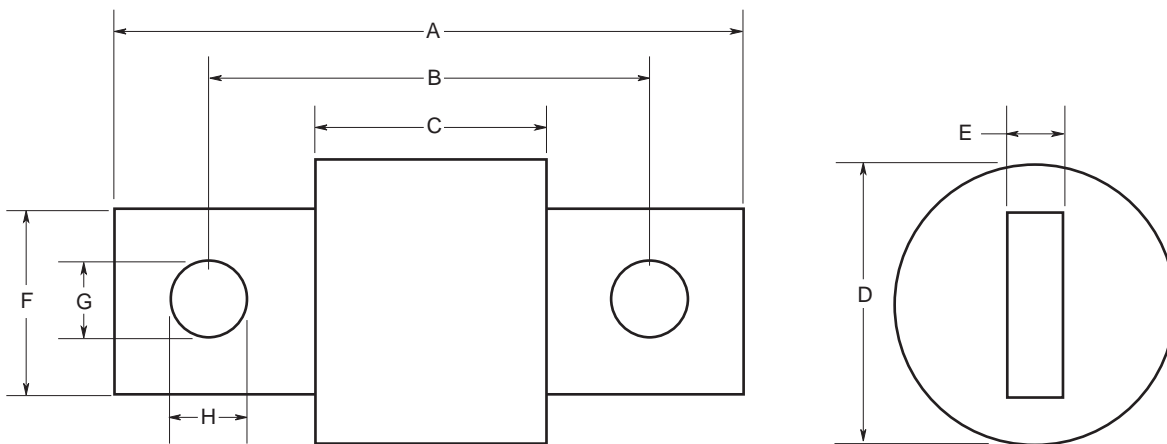

Figure 3: 500 – 1000A Range

Catalog Number E15SF(Amp) 150Vac/130Vdc

E15SF(Amp) 150Vac/130Vdc Electrical Characteristics				
Catalog Number	Rated Current RMS Amps	Melting I _t	Clearing I _t @ 150V	Watts Loss @ Rated Current
E15SF5	5	1.6	8	1.1
E15SF10	10	3.6	16	2.7
E15SF15	15	14.5	55	3.3
E15SF20	20	33.0	130	3.8
E15SF25	25	58.0	220	4.5
E15SF30	30	100.0	400	4.9
E15SF35	35	75.0	800	4.5
E15SF40	40	102.0	1000	5.1
E15SF45	45	133.0	1300	6.0
E15SF50	50	168.0	1600	7.3
E15SF60	60	250.0	2400	8.0

Catalog Number E15S(Amp) 150Vac/150Vdc*

E15S(Amp) 150Vac/150Vdc Electrical Characteristics				
Catalog Number	Rated Current RMS Amps	Melting I _t	Clearing I _t @ 150V	Watts Loss @ Rated Current
E15S70	70	467	4000	6.9
E15S80	80	670	6000	7.7
E15S100	100	1200	12000	9.0
E15S125	125	1870	18000	11.2
E15S150	150	2700	26000	13.5
E15S200	200	4780	45000	17.6
E15S250	250	7470	70000	22.5
E15S300	300	10760	100000	27.0
E15S350	350	15700	140000	30.6
E15S400	400	20340	180000	35.2
E15S500	500	39000	120000	35.0
E15S600	600	46000	140000	47.0
E15S700	700	75000	220000	49.0
E15S800	800	92000	280000	58.0
E15S1000	1000	170000	510000	60.0

Interrupting Rating 200kA RMS Symmetrical.
 *150Vdc rating applies to 70 – 800A only.

UL/CSA Fuses
Current Limiting

UL/CSA Fuses
General Purpose

Special
Purpose Fuses

Canadian
Fuses & Holders

Medium
Voltage Fuses

Fuse Blocks,
Holders & Misc.

Application
Section

Time-Current, Minimum Melting Curves

**E15SF(Amp) High Speed Fuse
5 – 60A, 150V**

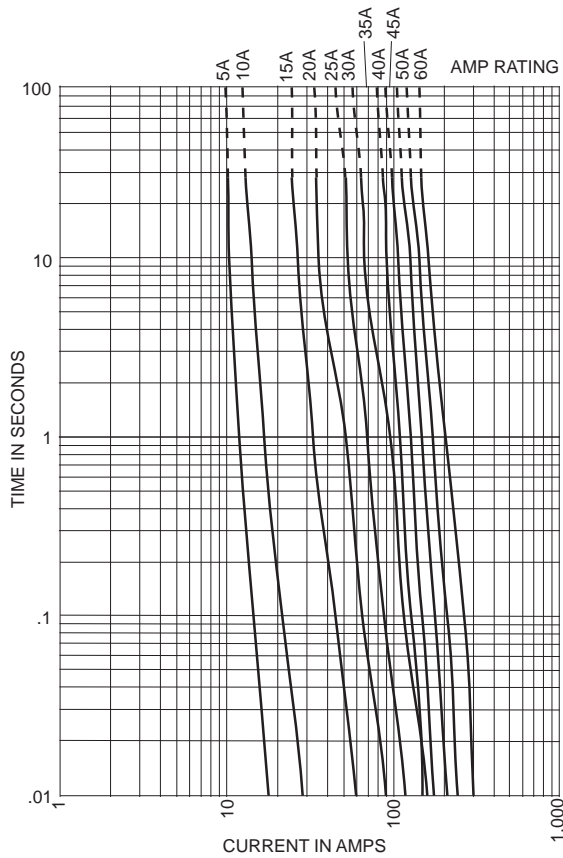

**E15S(Amp) High Speed Fuse
70 – 1000A, 150V**

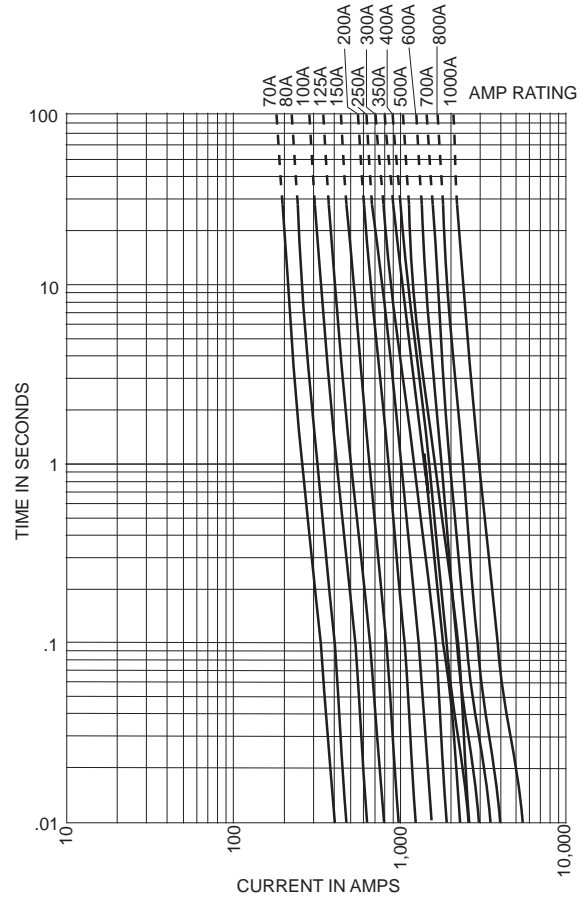

Peak Let-Through Current Curves

**E15SF(Amp) High Speed Fuse
5 – 60A, 150V**

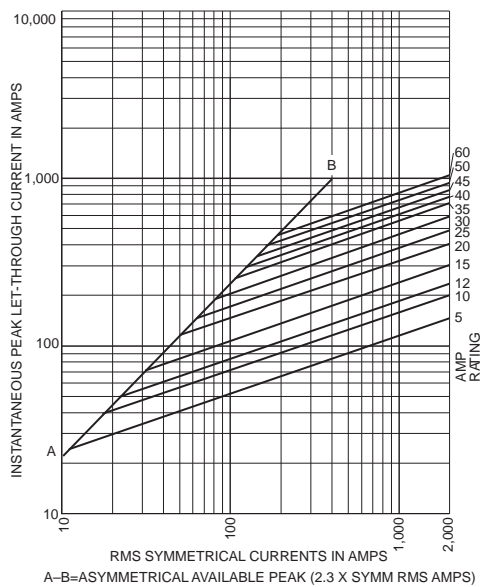

**E15S(Amp) High Speed Fuse
70 – 1000A, 150V**

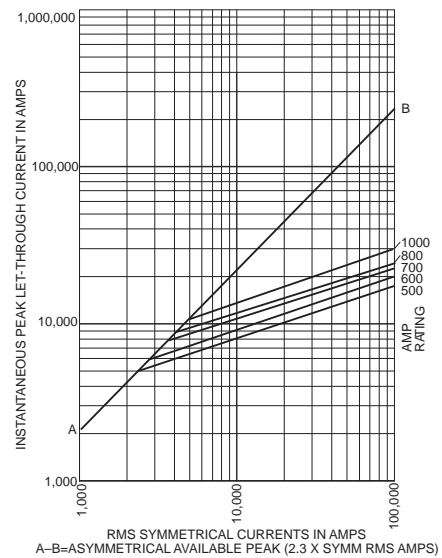

Catalog Number E25SFX(Amp) 5 – 30A, 250Vac/250Vdc

Dimensions - inches (mm)

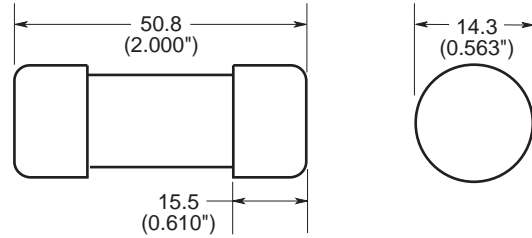

Catalog Number E25S(Amp) 35 – 2500A

E25S(Amp) Dimensions - inches (mm)										
Catalog Numbers	Figure	A	B	C	D	E	F	G	H	J
E25S35 – 60	1	3.19 (81.0)	0.81 (20.6)	1.59 (40.4)	2.59 (65.8)	2.25 (57.2)	0.34 (8.6)	0.63 (16.0)	0.13 (3.3)	0.52 (13.2)
E25S70 – 200	1	3.13 (79.5)	1.22 (31.0)	1.59 (40.4)	2.44 (62.0)	2.19 (55.6)	0.34 (8.6)	1.00 (25.4)	0.19 (4.8)	0.47 (11.9)
E25S225 – 600	1	3.84 (97.5)	1.50 (38.1)	1.59 (40.4)	2.94 (74.7)	2.25 (57.2)	0.41 (10.4)	1.00 (25.4)	0.25 (6.4)	0.75 (19.1)
E25S700 – 800	1	3.84 (97.5)	2.00 (50.8)	1.59 (40.4)	3.03 (77.0)	2.28 (57.9)	0.41 (10.4)	1.50 (38.1)	0.25 (6.4)	0.78 (19.8)
E25S1000 – 1200	2	2.59 (65.8)	3.00 (76.2)	1.50 (38.1)	—	—	—	—	—	—
E25S1500 – 2500	3	2.59 (65.8)	3.50 (88.9)	1.50 (38.1)	1.50 (38.1)	—	—	—	—	—

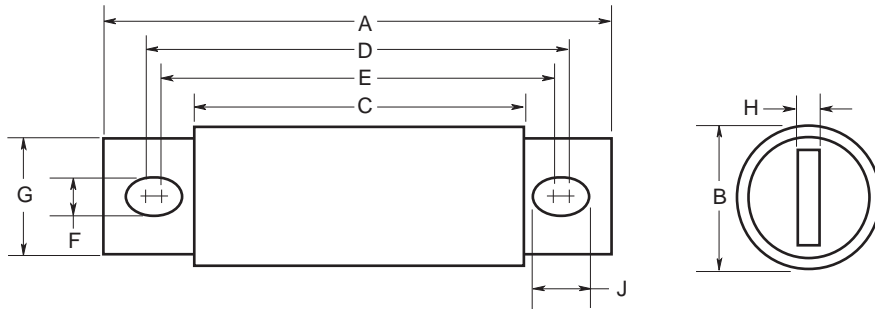

Figure 1: 35 – 800A Range

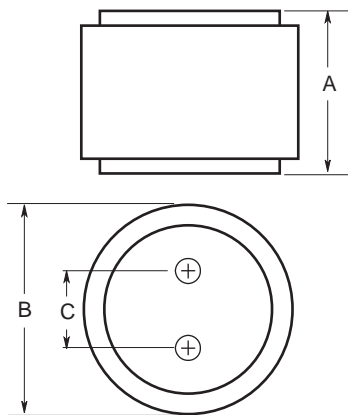

Figure 2: 1000 – 1200A Range

Thread Depth
Tapped 3/8" -24 x 1/2"

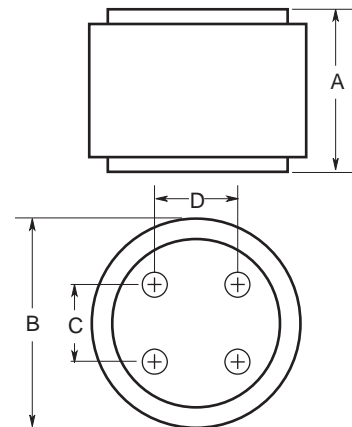
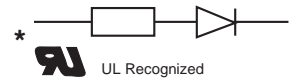

Figure 3: 1500 – 2500A Range

Catalog Number E25S(Amp) 250Vac/250Vdc*



UL/CSA Fuses
Current Limiting

UL/CSA Fuses
General Purpose

Special
Purpose Fuses

Canadian
Fuses & Holders

Medium
Voltage Fuses

Fuse Blocks,
Holders & Misc.

Application
Section

E25S(Amp) 250Vac/250Vdc* Electrical Characteristics

Catalog Numbers	Rated Current RMS Amps	Melting I ² t	Clearing I ² t @ 250V	Watts Loss @ Rated Current
E25SFX5	5	1.6	15	1.3
E25SFX10	10	3.6	24	3.4
E25SFX15	15	14.5	83	3.8
E25SFX20	20	33.0	190	4.6
E25SFX25	25	58.0	290	5.3
E25SFX30	30	100.0	520	5.6
E25S35	35	50.0	230	4.2
E25S40	40	60.0	310	5.2
E25S45	45	80.0	390	5.7
E25S50	50	100	520	6.0
E25S60	60	140	740	8.1
E25S70	70	330	1400	7.2
E25S80	80	430	1850	8.1
E25S90	90	570	2450	9.0
E25S100	100	740	3150	10.0
E25S125	125	1130	4850	12.5
E25S150	150	1620	6950	15.7
E25S175	175	2170	9300	18.5
E25S200	200	2790	12000	22.0
E25S225	225	3210	14700	24.0
E25S250	250	3960	18100	27.0
E25S275	275	4720	21600	31.0
E25S300	300	6000	27300	32.0
E25S350	350	10600	48600	39.0
E25S400	400	14500	66100	44.0
E25S450	450	22100	101000	49.0
E25S500	500	28000	128000	54.0
E25S600	600	41100	188000	62.0
E25S700	700	48800	190000	72.0
E25S800	800	59000	230000	84.0
E25S1000	1000	44000	360000	100.0
E25S1200	1200	92000	750000	103.0
E25S1500	1500	120000	880000	140.0
E25S1600	1600	160000	1200000	140.0
E25S2000	2000	320000	2300000	151.0
E25S2500	2500	670000	4700000	163.0

Interrupting Rating 200kA RMS Symmetrical.
*250Vdc rating and UL Recognition on 5 – 800A only.

Time-Current, Minimum Melting Curves

E25SFX(Amp) High Speed Fuse
5 – 30A, 250V

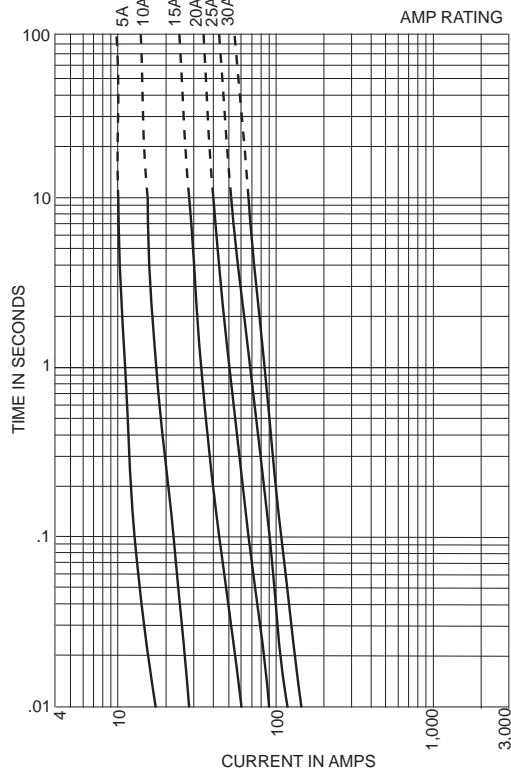

E25S(Amp) High Speed Fuse
35 – 800A, 250V

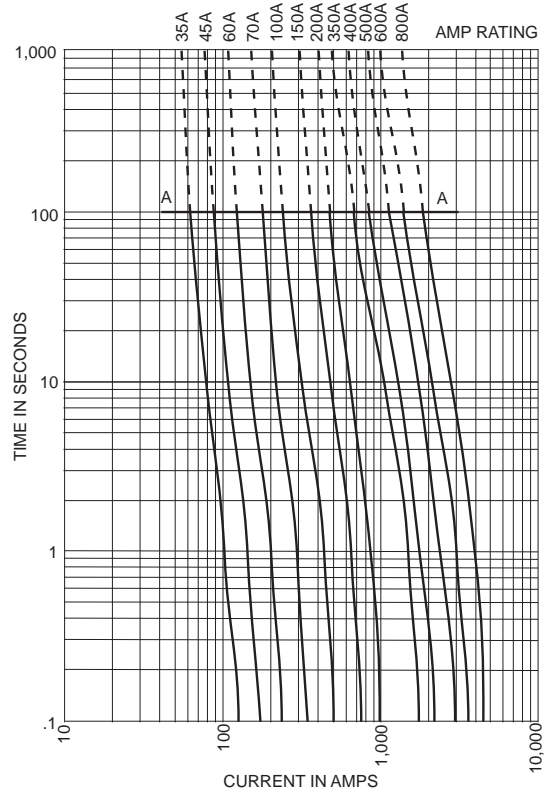

Peak Let-Through Current Curves

E25SFX(Amp) High Speed Fuse
5 – 30A, 250V

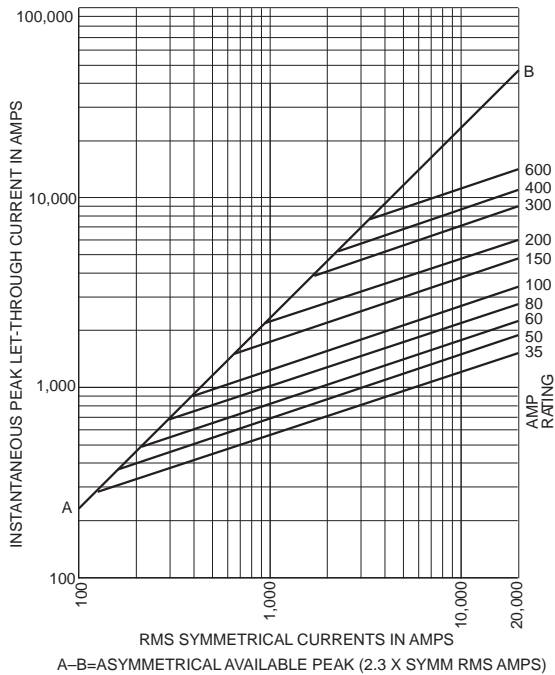

E25S(Amp) High Speed Fuse
35 – 800A, 250V

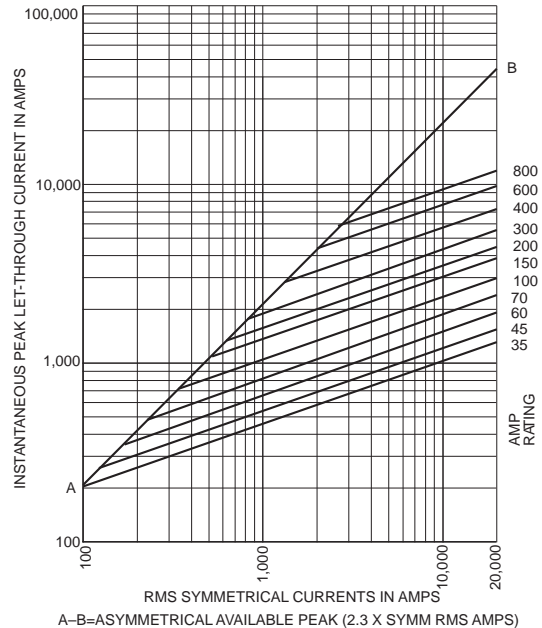

Time-Current, Minimum Melting Curves

E25S(Amp) High Speed Fuse
1000 – 2500A, 250V

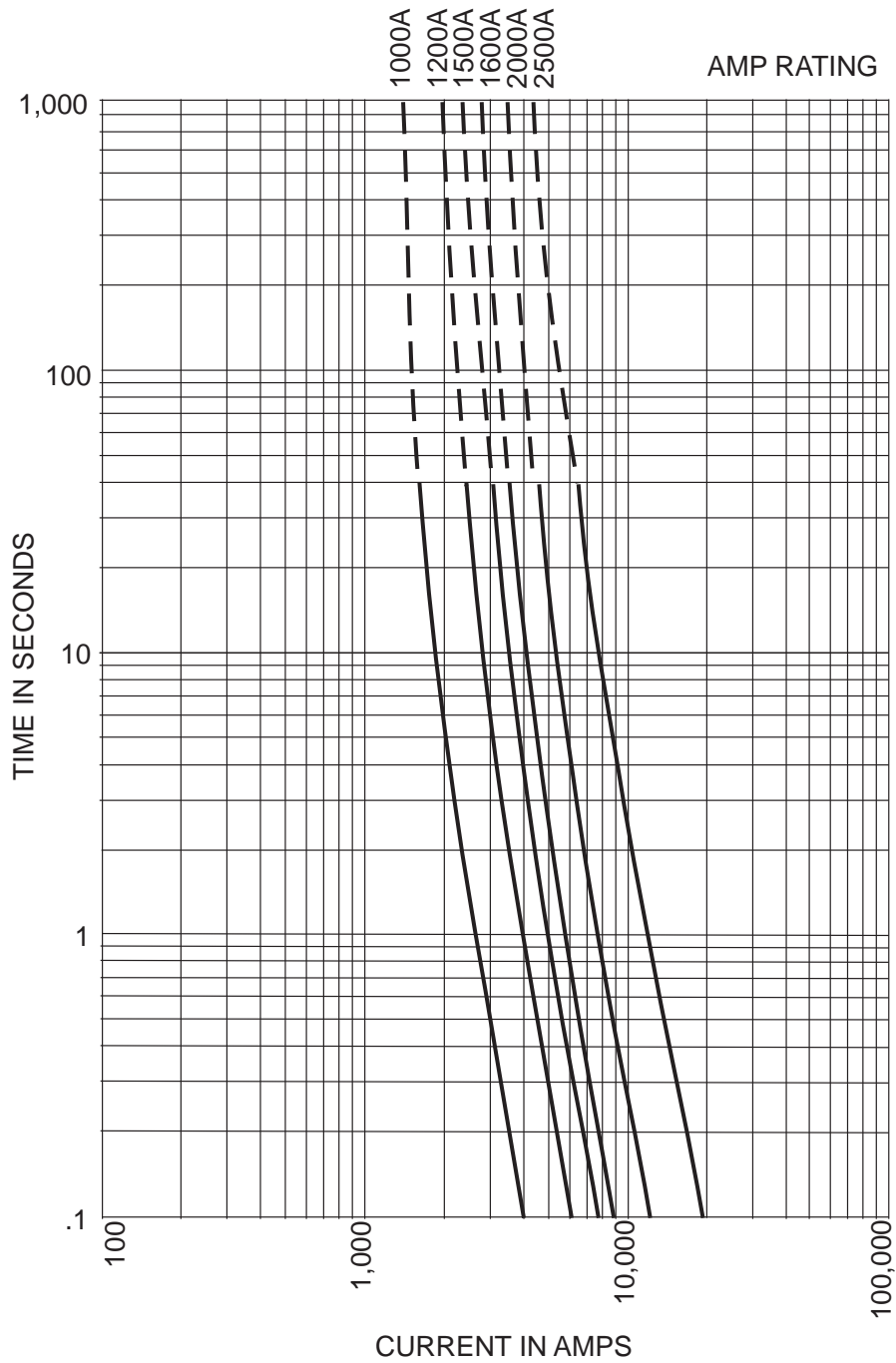

UL/CSA Fuses
Current Limiting

UL/CSA Fuses
General Purpose

Special
Purpose Fuses

Canadian
Fuses & Holders

Medium
Voltage Fuses

Fuse Blocks,
Holders & Misc.

Application
Section

Catalog Number E50SF(Amp) 5 – 30A, 500Vac/500Vdc

Dimensions - inches (mm)

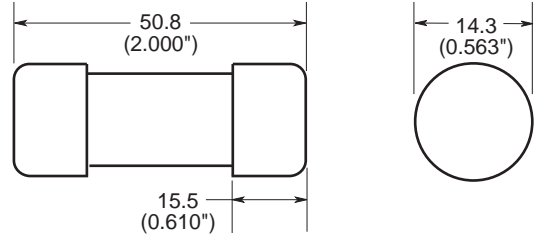

Catalog Number E50S(Amp) 35 – 1600A, 500Vac/500Vdc*

E50S(Amp) Dimensions - inches (mm)										
Catalog Numbers	Figure	A	B	C	D	E	F	G	H	J
E50S35 – 60	1	3.19 (81.0)	0.81 (20.6)	1.59 (40.4)	2.59 (65.8)	2.25 (57.2)	0.34 (8.6)	0.63 (16.0)	0.13 (3.3)	0.52 (13.2)
E50S70 – 100	1	3.63 (92.2)	1.00 (25.4)	2.09 (53.1)	3.03 (77.0)	2.69 (68.3)	0.34 (8.6)	0.75 (19.1)	0.13 (3.3)	0.52 (13.2)
E50S125 – 200	1	3.63 (92.2)	1.22 (31.0)	2.09 (53.1)	2.94 (74.7)	2.69 (68.3)	0.34 (8.6)	1.00 (25.4)	0.19 (4.8)	0.47 (11.9)
E50S225 – 400	1	4.34 (110.0)	1.50 (38.1)	2.09 (53.1)	3.44 (87.4)	2.75 (69.9)	0.41 (10.4)	1.00 (25.4)	0.25 (6.4)	0.75 (19.1)
E50S450 – 600	1	4.34 (110.0)	2.00 (50.8)	2.09 (53.1)	3.53 (89.7)	2.78 (70.6)	0.41 (10.4)	1.50 (38.1)	0.25 (6.4)	0.78 (19.8)
E50S700 – 800	1	6.34 (161.0)	2.50 (63.5)	2.09 (53.1)	4.97 (126.2)	3.44 (87.4)	0.53 (13.5)	2.00 (50.8)	0.38 (9.7)	1.30 (33.0)
E50S1000 – 1200	1	6.97 (177.0)	3.00 (76.2)	3.22 (81.8)	5.47 (138.8)	4.48 (113.7)	0.63 (15.9)	2.38 (60.3)	0.44 (11.1)	1.12 (28.4)
E50S1400 – 1600	2				See Drawing					

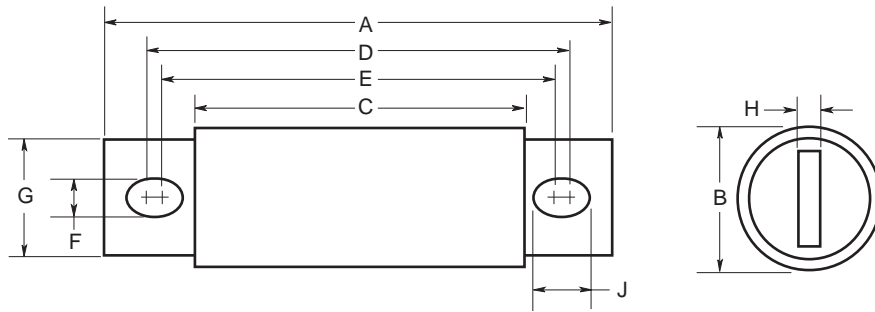

Figure 1: 35 – 1200A Range

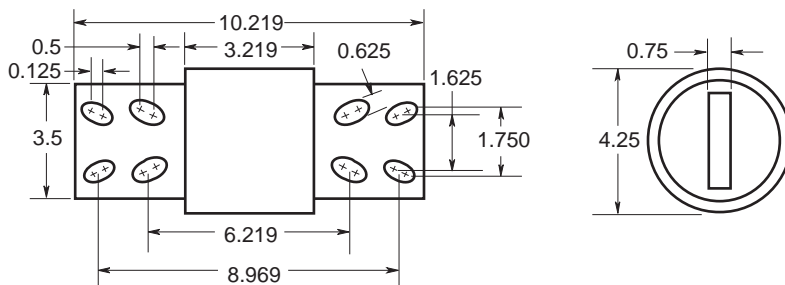
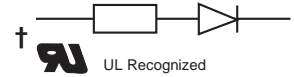

Figure 2: 1400 – 1600A Range

Catalog Number E50S(Amp) 500Vac/500Vdc*



E50S(Amp) 500Vac/500Vdc Electrical Characteristics				
Catalog Numbers	Rated Current RMS Amps	Melting I ² t	Clearing I ² t @ 500V	Watts Loss @ Rated Current
E50SF5	5	1.6	2.5	1.5
E50SF10	10	3.6	6.0	4.0
E50SF15	15	10.0	16	5.5
E50SF20	20	26.0	40	6.0
E50SF25	25	49.0	75	7.0
E50SF30	30	58.0	90	9.0
E50S35	35	130	920	5.5
E50S40	40	180	1250	6.9
E50S50	50	280	1930	8.0
E50S60	60	410	2700	9.4
E50S70	70	290	1860	12.7
E50S80	80	430	2740	13.4
E50S90	90	590	3800	15.6
E50S100	100	730	4700	16.8
E50S125	125	1100	5950	24.0
E50S150	150	2000	10800	26.0
E50S175	175	2800	15300	30.0
E50S200	200	3900	21000	32.0
E50S225	225	4600	23300	39.0
E50S250	250	6300	32200	41.0
E50S275	275	7900	40300	46.0
E50S300	300	9800	49800	51.0
E50S325	325	13700	63800	53.0
E50S350	350	14500	72900	58.0
E50S400	400	19200	96700	65.0
E50S450	450	24700	127000	74.0
E50S500	500	29200	149000	84.0
E50S600	600	41300	206000	108.0
E50S700	700	55000	298000	120.0
E50S800	800	76200	409000	129.0
E50S1000	1000	92000	450000	145.0
E50S1200	1200	122000	600000	180.0
E50S1400	1400	200000	1000000	210.0
E50S1600	1600	290000	1400000	230.0

Interrupting Rating 200kA RMS Symmetrical.

*500Vdc rating and UL Recognition on 5 – 800A only.

†UL Recognition on 5 – 1200 amps only.

UL/CSA Fuses
Current Limiting

UL/CSA Fuses
General Purpose

Special
Purpose Fuses

Canadian
Fuses & Holders

Medium
Voltage Fuses

Fuse Blocks,
Holders & Misc.

Application
Section

Time-Current, Minimum Melting Curves

E50SF(Amp) 5 – 30A, 500V
E50S(Amp) 1000 – 1600A, 500V

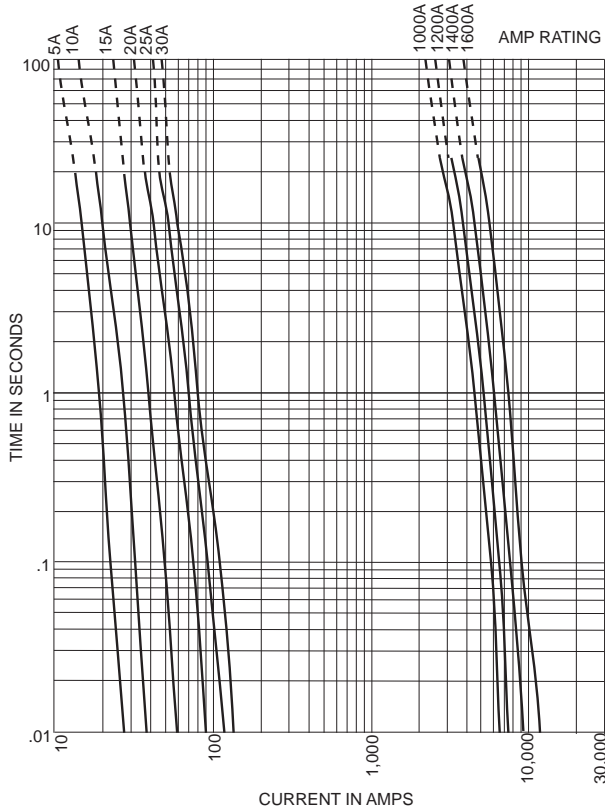

E50S(Amp) High Speed Fuse
35 – 800A, 500V

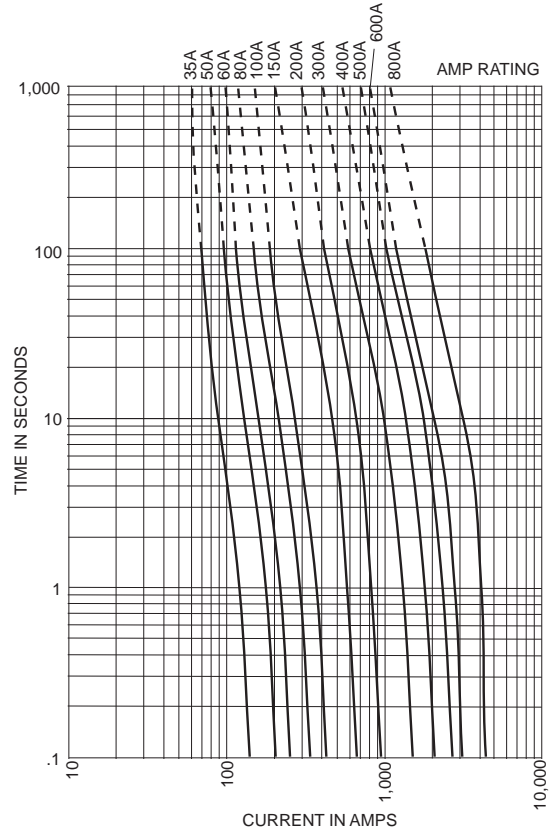

Peak Let-Through Current Curves

E50SF(Amp) High Speed Fuse
5 – 30A, 500V

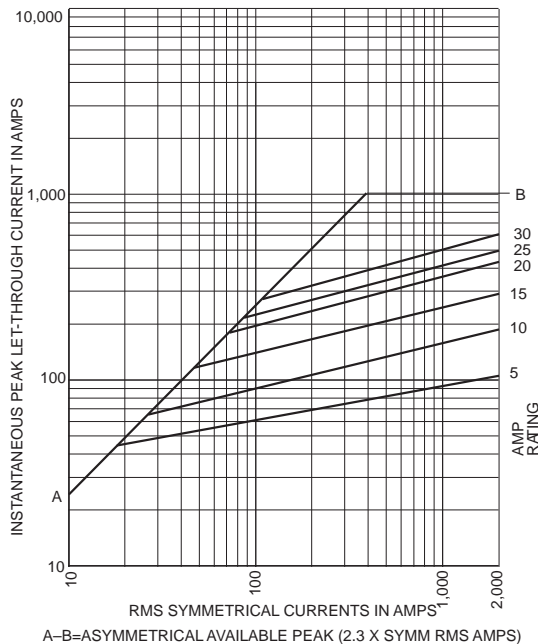

E50S(Amp) High Speed Fuse
35 – 1600A, 500V

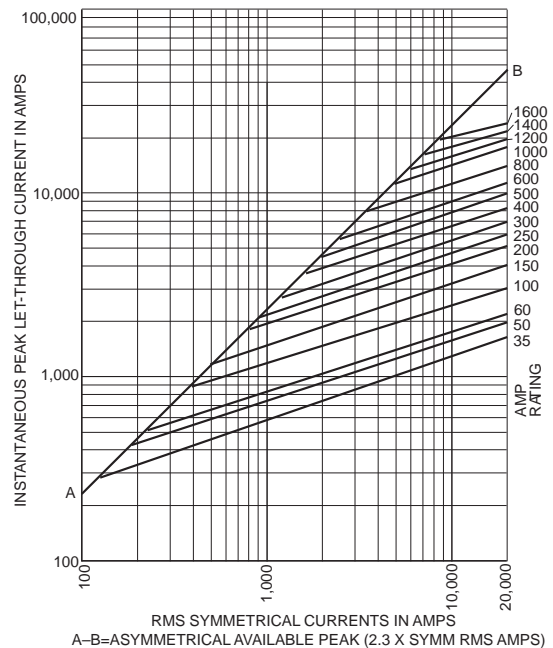

Catalog Number E60C(1 – 1000A) 600Vac or Less

NOTE: Edison 600V rectifier fuses are for replacement purposes only. For new applications, refer to E70S(Amp) fuses.

Amp Ratings E60C(AMP) 600V					
4	12	40	90	200	450
5	15	45	100	225	500
6	20	50	110	250	600
7	25	60	125	300	700
8	30	70	150	350	800
10	35	80	175	400	1000

E60C(Amp) Dimensions - inches											
Catalog Numbers	Figure	A	B1	B2	B3	C	D	E	F	G	H
E60C4 – 30	1	2.875	2.500	—	—	1.875	0.406	—	0.563	0.063	0.257
E60C35 – 60	2	4.375	—	3.750	3.500	2.750	0.625	0.343	0.813	0.094	0.468
E60C70 – 100	2	5.000	—	4.167	3.656	2.906	0.750	0.406	1.000	0.125	0.609
E60C110 – 200	2	5.500	—	4.375	3.063	2.906	1.125	0.406	1.500	0.188	0.767
E60C225 – 400	1	6.250	4.750	—	—	3.000	1.625	—	2.000	0.250	0.563
E60C450 – 800	1	6.250	4.750	—	—	3.063	2.000	—	2.500	0.250	0.563
E60C1000	1	7.250	4.750	—	—	3.063	2.750	—	3.500	0.375	0.563

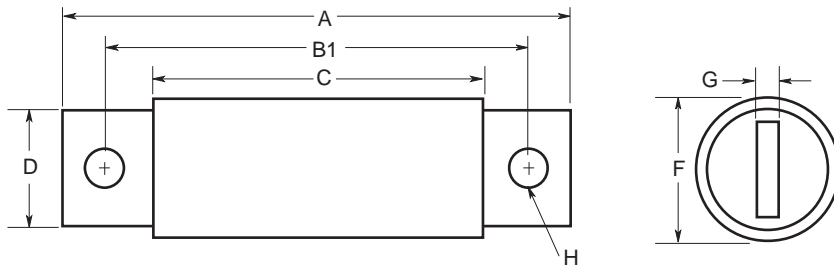

Figure 1: 4 – 30A & 225 – 1000A Range

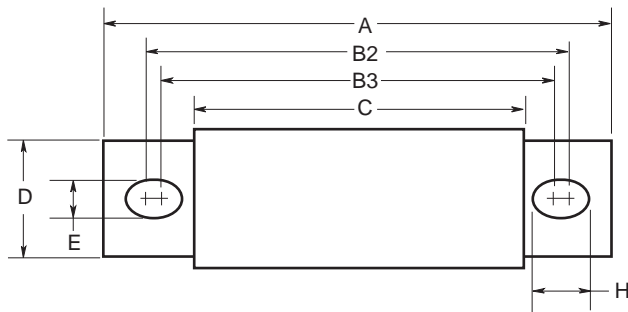

Figure 2: 35 – 200A Range

UL/CSA Fuses
Current Limiting

UL/CSA Fuses
General Purpose

Special
Purpose Fuses

Canadian
Fuses & Holders

Medium
Voltage Fuses

Fuse Blocks,
Holders & Misc.

Application
Section

Total Clearing Time Curves

E60C1 – 800A, 600Vac

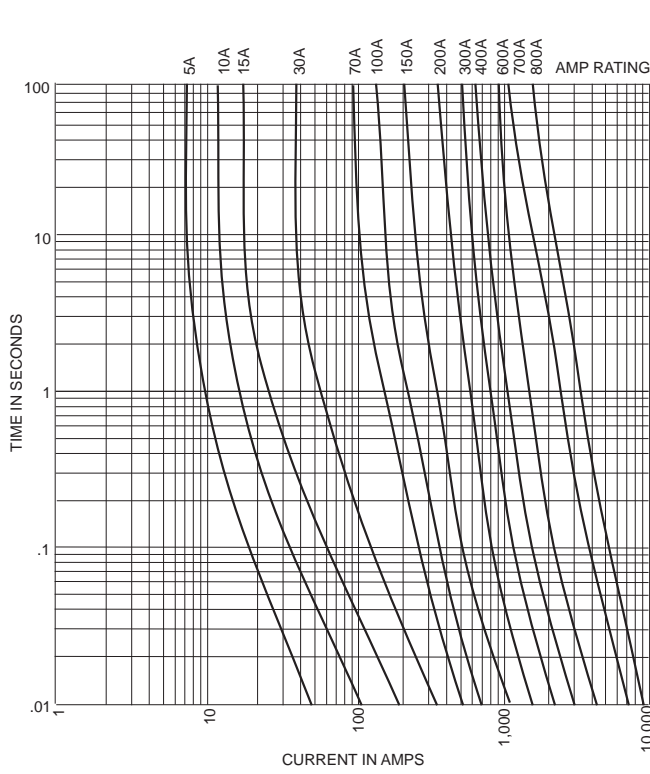

Average Melting Time-Current Curves

E60C35 – 60A, 600Vac

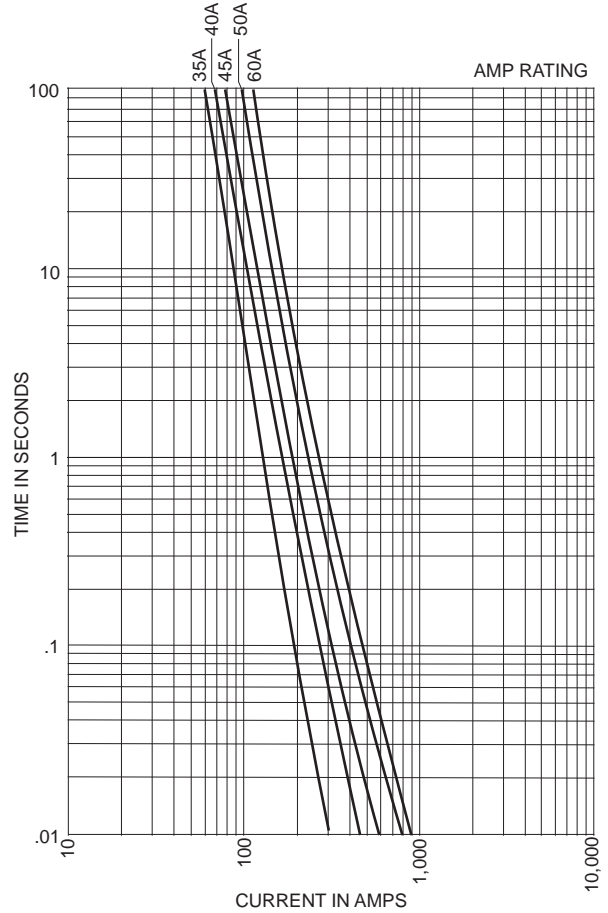

Catalog Number E60SF(5 – 30A) 600Vac or Less

NOTE: Edison 600V rectifier fuses are for replacement purposes only. For new applications, refer to E70S(Amp) fuses.

Amp Ratings E60SF(AMP) 600V						
5	10	12	15	20	25	30

E60SF(AMP) Dimensions - inches (mm)	
Catalog Numbers E60SF5 – 30	See Drawing

Dimensions - inches (mm)

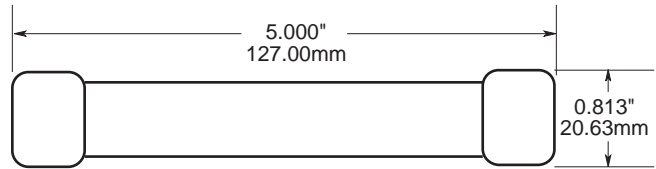

Catalog Number E60S(35 – 600A) 600Vac or Less

Amp Ratings E60S(AMP) 600V						
35	50	80	125	200	300	450
40	60	90	150	225	350	500
45	70	100	175	250	400	600

E60S(Amp) Dimensions - inches								
Catalog Numbers	Figure	A	B	C	D	F	G	H
E60S35 – 60	1	See Drawing						
E60S70 – 100	2	4.406	3.656	2.906	0.750	1.000	0.125	0.313
E60S110 – 200	2	4.406	3.656	2.906	0.875	1.219	0.188	0.313
E60S225 – 400	2	5.125	4.063	2.906	1.000	1.500	0.250	1.094
E60S450 – 600	2	5.125	4.063	2.875	1.500	2.000	0.250	1.094

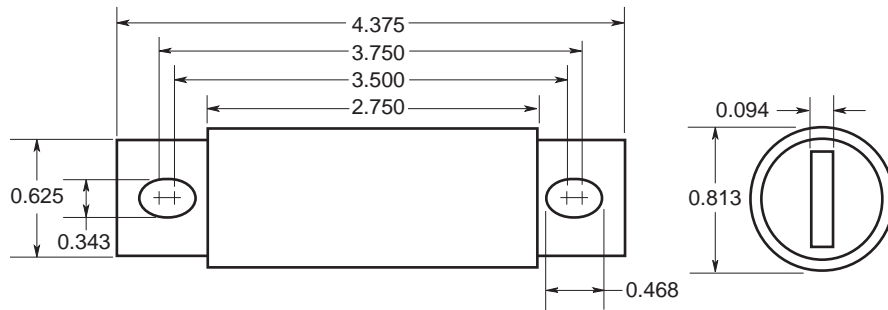

Figure 1: 35 – 60A Range

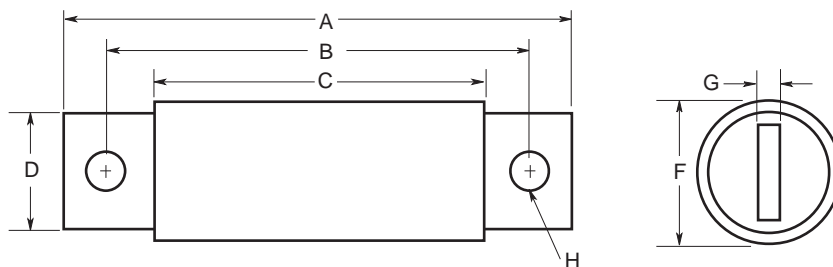
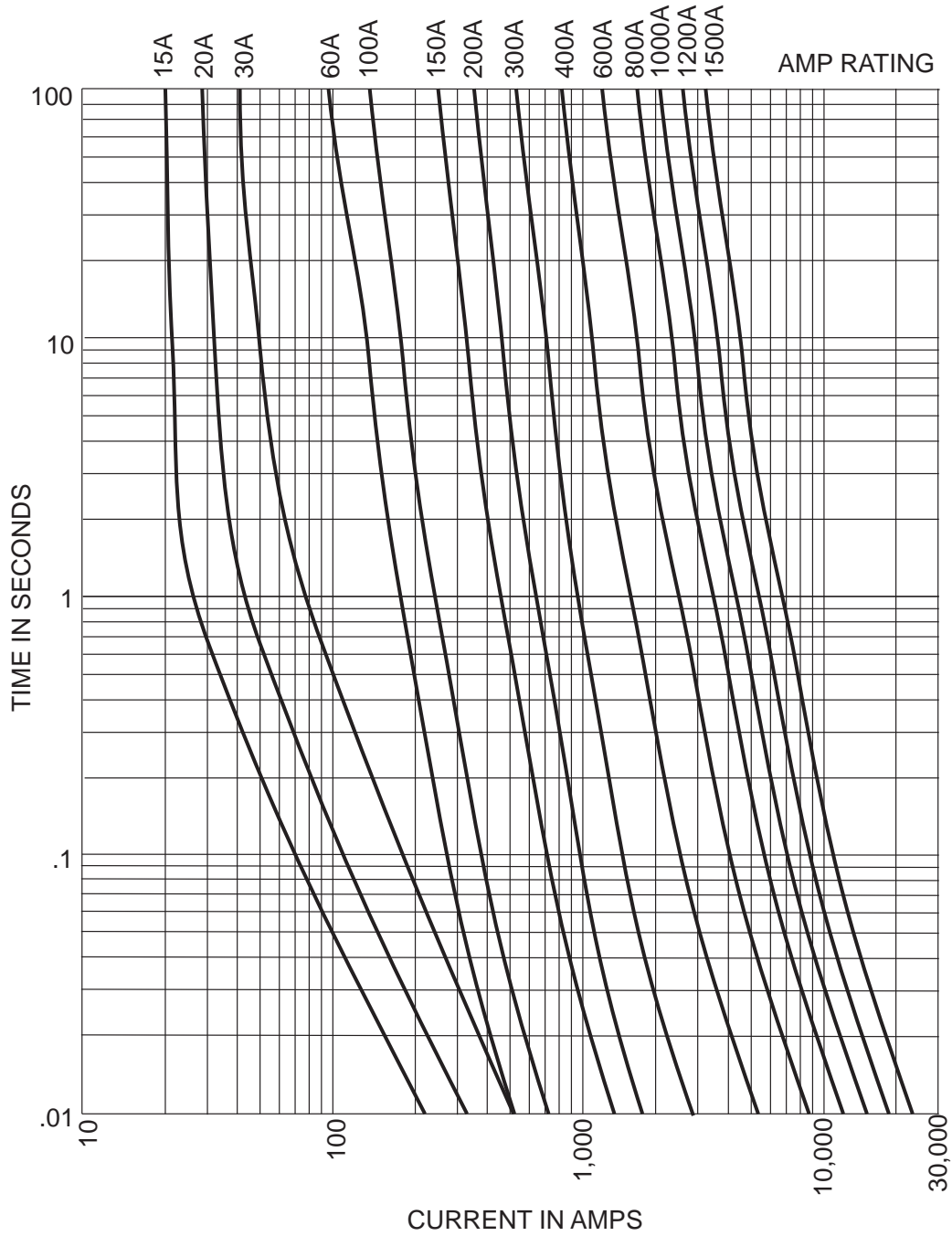

Figure 2: 70 – 600A Range

Total Clearing Time Curves E60S(Amp) 600Vac



Catalog Number E70SF(5 – 30A) 700Vac/700Vdc

E70SF(AMP) Dimensions - inches (mm)	
Catalog Number E70SF5 – 30	See Drawing

Dimensions - inches (mm)

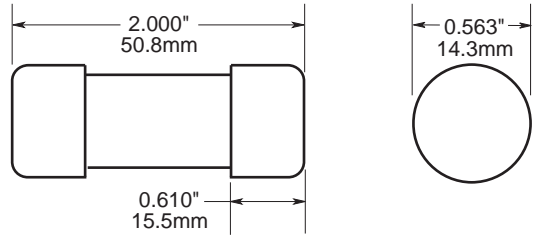

Catalog Number E70S(35 – 1200A) 700Vac/700Vdc*

E70S(Amp) Dimensions - inches (mm)										
Catalog Numbers	Figure	A	B	C	D	E	F	G	H	J
E70S35 – 60	1	4.38 (111)	1.00 (25.4)	2.84 (72.1)	3.78 (96)	3.44 (87.4)	0.34 (8.6)	0.75 (19.1)	0.13 (3.3)	0.52 (13.2)
E70S70 – 100	1	4.38 (111)	1.22 (31)	2.84 (72.1)	3.69 (93.7)	3.44 (87.4)	0.34 (8.6)	1.00 (25.4)	0.19 (4.8)	0.47 (11.9)
E70S125 – 200	1	5.09 (129)	1.50 (38.1)	2.84 (72.1)	4.19 (106)	3.50 (88.9)	0.41 (10.4)	1.00 (25.4)	0.25 (6.4)	0.75 (19.1)
E70S225 – 400	1	5.09 (129)	2.00 (50.8)	2.84 (72.1)	4.28 (109)	3.53 (89.7)	0.41 (10.4)	1.50 (38.1)	0.25 (6.4)	0.78 (19.8)
E70S450 – 600	1	7.09 (180)	2.50 (63.5)	2.84 (72.1)	5.72 (145)	4.19 (106)	0.53 (13.5)	2.00 (50.8)	0.38 (9.7)	1.30 (33)
E70S700 – 800	1	6.63 (168)	2.00 (50.8)	2.84 (72.1)	5.56 (141.2)	5.06 (128.6)	0.63 (15.9)	1.50 (38.1)	0.25 (6.4)	0.88 (22.2)
E70S900 – 1000	2	See Drawing								
E70S1200	3	See Drawing								

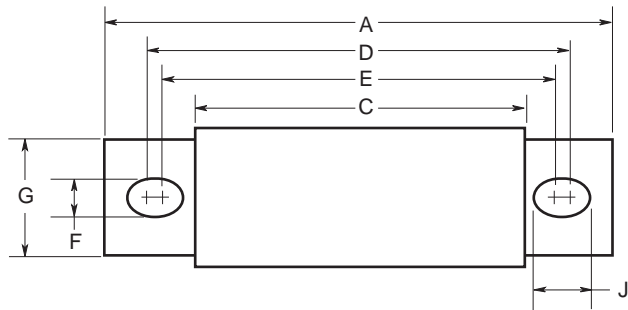

Figure 1: 35 – 800A Range

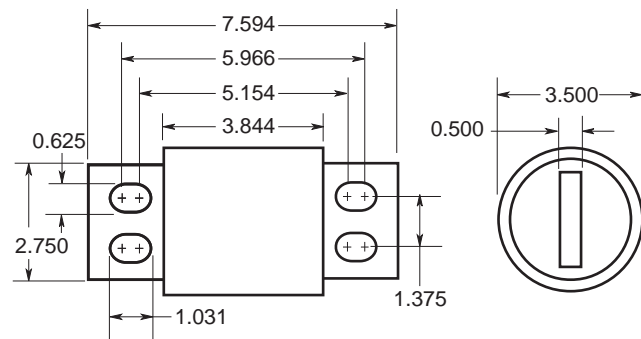

Figure 2: 900 – 1000A Range

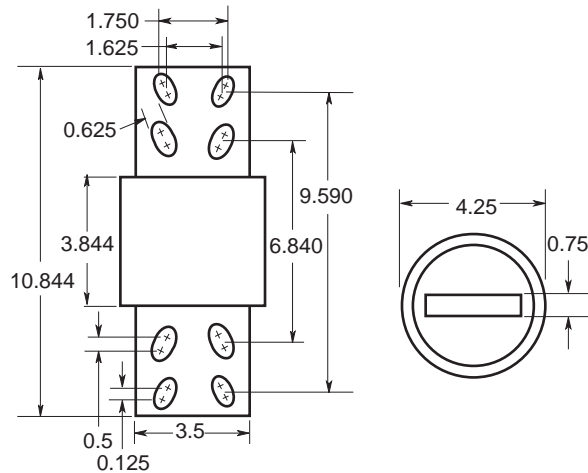
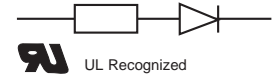

Figure 3: 1200A Range

Catalog Number E70S(Amp) 700Vac/700Vdc*



E70S(Amp) 700Vac/700Vdc Electrical Characteristics				
Catalog Number	Rated Current RMS Amps	Melting I ² t	Clearing I ² t @ 700V	Watts Loss @ Rated Current
E70SF5	5	1.6	4	1.5
E70SF10	10	3.6	10	4.0
E70SF15	15	10.0	22	5.5
E70SF20	20	26.0	60	6.0
E70SF25	25	44.0	130	7.0
E70SF30	30	58.0	150	9.0
E70S35	35	80.0	370	9.8
E70S40	40	100	460	11.5
E70S50	50	200	840	13.4
E70S60	60	310	1300	15.1
E70S70	70	470	2200	17.0
E70S80	80	620	2900	20.0
E70S90	90	800	3700	23.0
E70S100	100	1030	4800	25.0
E70S125	125	1800	7300	28.0
E70S150	150	2900	11700	32.0
E70S175	175	4200	16700	35.0
E70S200	200	5600	22000	43.0
E70S225	225	7700	31300	45.0
E70S250	250	10500	42500	48.0
E70S300	300	17600	71200	58.0
E70S350	350	23700	95600	65.0
E70S400	400	31000	125000	78.0
E70S450	450	36400	137000	94.0
E70S500	500	45200	170000	107.0
E70S600	600	66700	250000	122.0
E70S700	700	54000	300000	125.0
E70S800	800	78000	450000	140.0
E70S900	900	91500	530000	150.0
E70S1000	1000	120000	600000	170.0
E70S1200	1200	195000	1100000	190.0

Interrupting Rating 200kA RMS Symmetrical
 *700Vdc rating applies to 5 – 800A only.

Pre-Arcing Time-Current Curves

E70SF(Amp)
5 – 30A, 700V

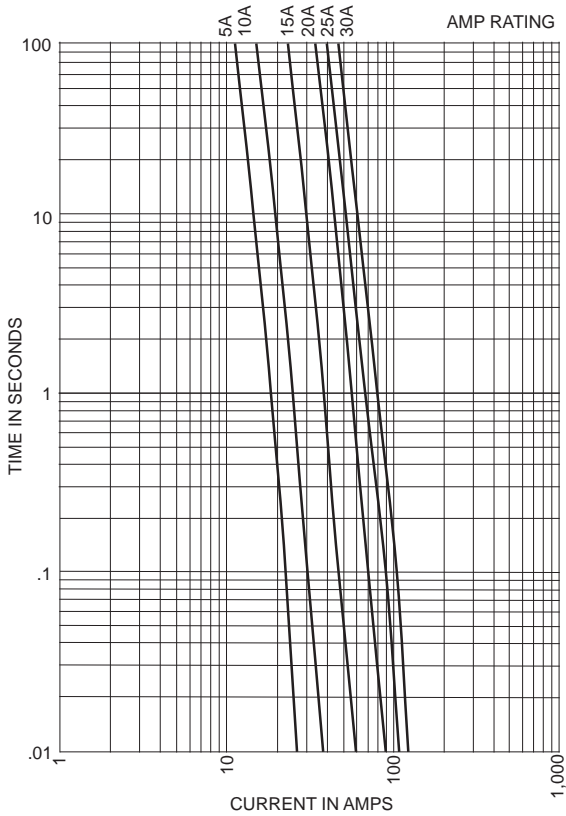

Minimum Melt Time-Current Curves

E70S(Amp)
35 – 600A, 700V

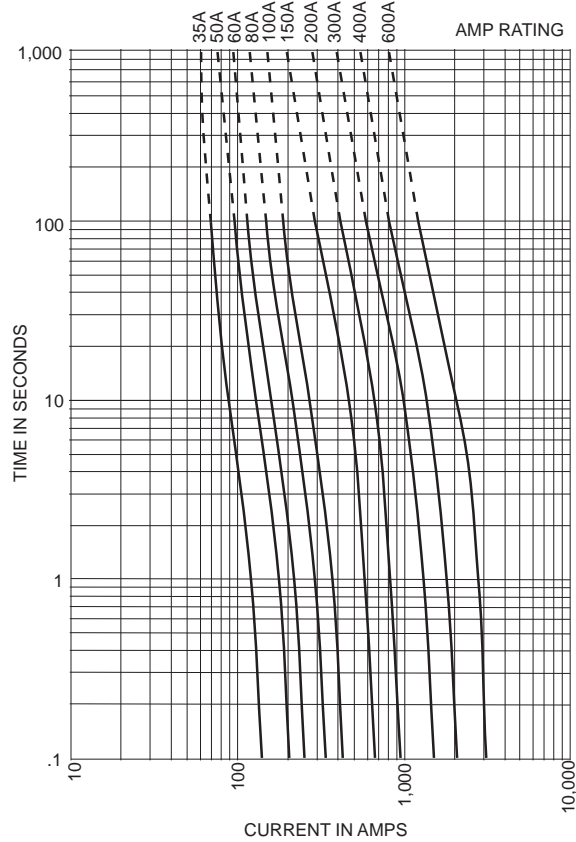

Peak Let-Through Current Curves

E70SF(Amp)
5 – 30A, 700V

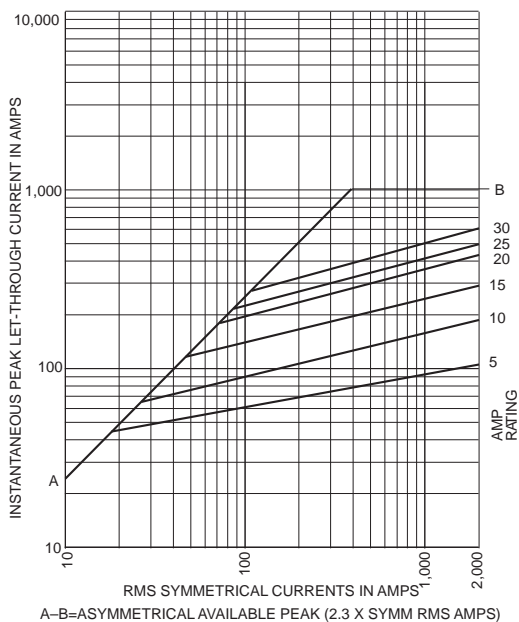

A-B=ASYMMETRICAL AVAILABLE PEAK (2.3 X SYMM RMS AMPS)

E70S(Amp)
35 – 600A, 700V

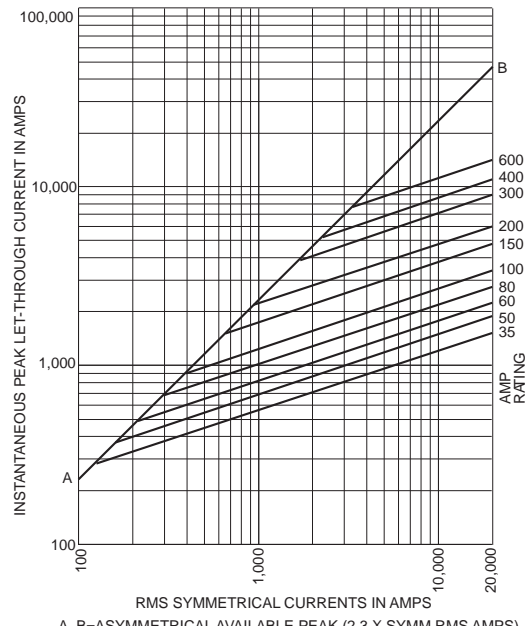

A-B=ASYMMETRICAL AVAILABLE PEAK (2.3 X SYMM RMS AMPS)

UL/CSA Fuses
Current Limiting

UL/CSA Fuses
General Purpose

Special
Purpose Fuses

Canadian
Fuses & Holders

Medium
Voltage Fuses

Fuse Blocks,
Holders & Misc.

Application
Section

UL/CSA Fuses
Current Limiting

UL/CSA Fuses
General Purpose

Special
Purpose Fuses

Canadian
Fuses & Holders

Medium
Voltage Fuses

Fuse Blocks,
Holders & Misc.

Application
Section

Minimum Melt Time-Current Curves

E70S(Amp)
700 – 1200A, 700V

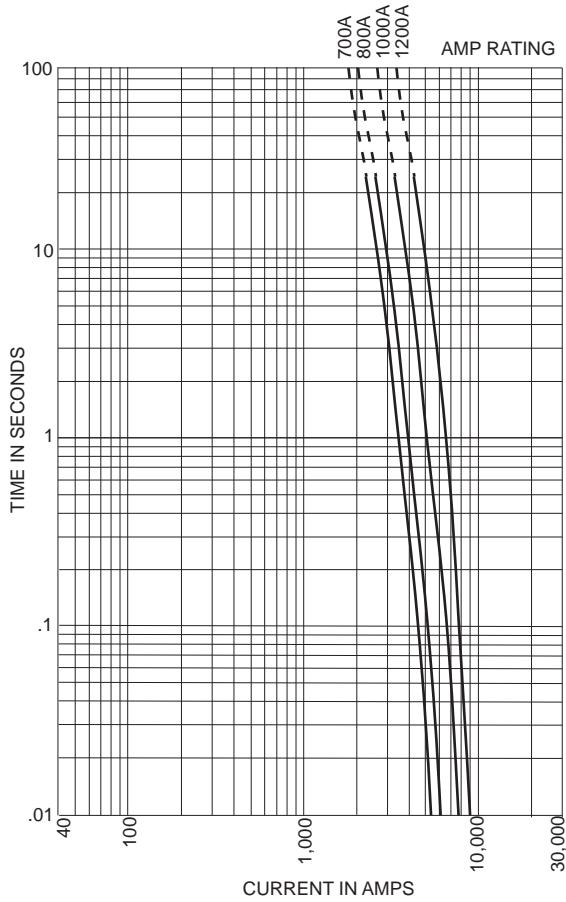

Peak Let-Through Current Curves

E70S(Amp)
700 – 1200A, 700V

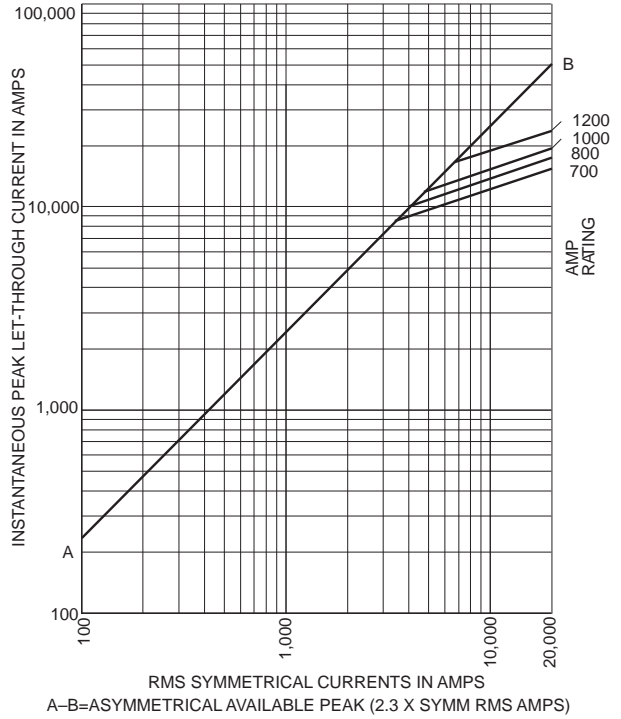

Catalog Number E100SF(20 – 30A) 1000Vac/800Vdc

E100SF(AMP) Dimensions - inches (mm)	
Catalog Numbers E100SF20 – 30	See Drawing

Dimensions - inches (mm)

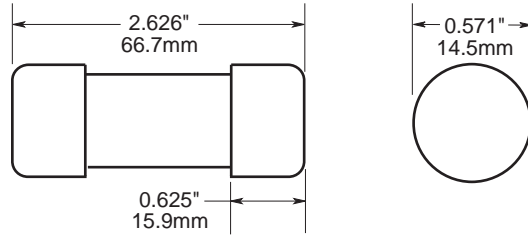

Catalog Number E100S(40 – 800A) 1000Vac/700Vdc

E100S(Amp) Dimensions - inches (mm)										
Catalog Numbers	Figure	A	B	C	D	E	F	G	H	J
E100S40 – 60	1	5.00 (127.0)	0.94 (23.9)	3.11 (79.0)	4.24 (107.6)	4.18 (106.2)	0.35 (8.9)	0.75 (19.1)	0.13 (3.2)	0.38 (9.7)
E100S70 – 100	1	4.93 (125.3)	1.13 (28.6)	3.09 (78.4)	4.27 (108.4)	4.16 (105.6)	0.35 (8.9)	1.00 (25.4)	0.19 (4.8)	0.41 (10.3)
E100S125 – 200	1	5.69 (144.4)	1.53 (38.8)	3.26 (82.8)	4.63 (117.6)	4.58 (116.4)	0.45 (11.3)	1.00 (25.4)	0.25 (6.4)	0.47 (11.9)
E100S250 – 400	1	5.77 (146.5)	2.00 (50.8)	3.50 (88.9)	4.81 (122.2)	4.15 (105.4)	0.43(9.1)	1.50 (38.1)	0.25 (6.4)	0.76 (19.4)
E100S500 – 600	1	7.20 (182.9)	2.50 (63.5)	3.47 (88.0)	5.98 (152.0)	4.71 (119.5)	0.56 (14.3)	2.00 (50.8)	0.38 (9.5)	1.20 (30.5)
E100S800	1	6.81 (173.0)	3.50 (88.9)	3.31 (84.1)	5.47 (139.0)	4.96 (126.0)	0.63 (15.9)	2.75 (69.9)	0.50 (12.7)	0.88 (22.4)

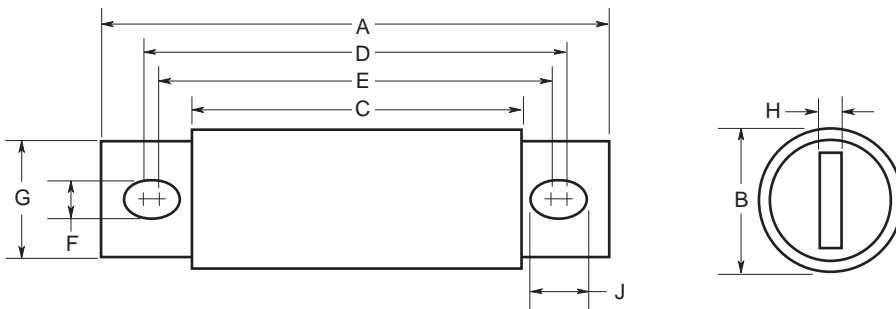
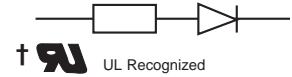

Figure 1: 40 – 800A Range

Catalog Number E100S(Amp) 1000Vac/700Vdc*



E100S(Amp) 1000Vac/700Vdc Electrical Characteristics:

Catalog Number	Rated Current RMS Amps	Melting I ² t	Clearing I ² t @ 1000V	Watts Loss @ Rated Current
E100SF20	20	25.0	220	9.0
E100SF25	25	33.0	350	11.0
E100SF30	30	52.0	450	14.0
E100S40	40	300	2500	9.8
E100S50	50	470	3500	8.0
E100S60	60	670	5000	10.0
E100S70	70	1100	6900	11.0
E100S80	80	1550	9700	12.0
E100S90	90	1900	12000	13.0
E100S100	100	2800	17500	14.0
E100S125	125	4800	35000	15.0
E100S150	150	6300	45000	16.0
E100S175	175	7500	65000	25.0
E100S200	200	11700	80000	30.0
E100S250	250	9000	50000	32.0
E100S300	300	15000	80000	50.0
E100S350	350	22000	120000	56.0
E100S400	400	32000	180000	62.0
E100S500	500	28500	155000	95.0
E100S600	600	646500	260000	105.0
E100S800	800	87000	500000	182.0

Interrupting Rating 200kA RMS Symmetrical

*Amp ratings 20 – 500 rated up to 800Vdc.

†UL Recognition through 200A only.

Pre-Arcing Time-Current Curves

E100SF(Amp)
20 – 30A, 1000Vac/800Vdc

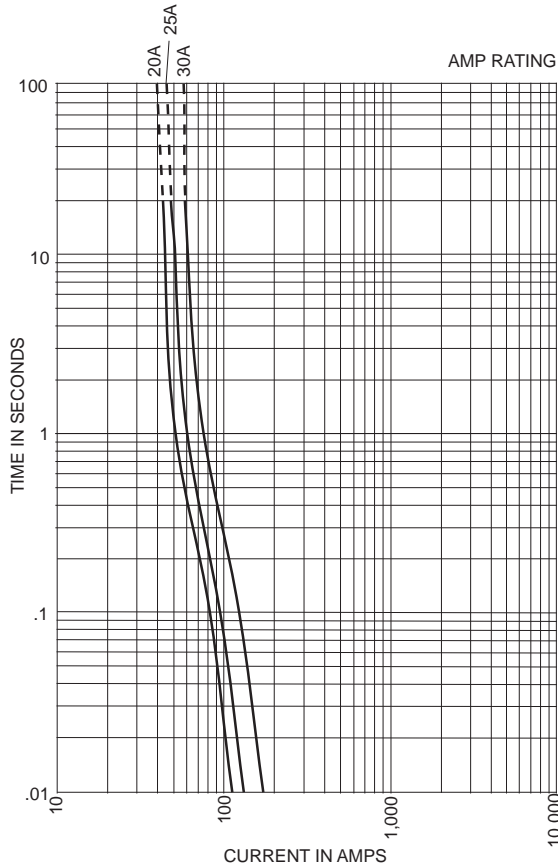

Minimum Melt Time-Current Curves

E100S(Amp)
40 – 600A, 1000Vac/700Vdc

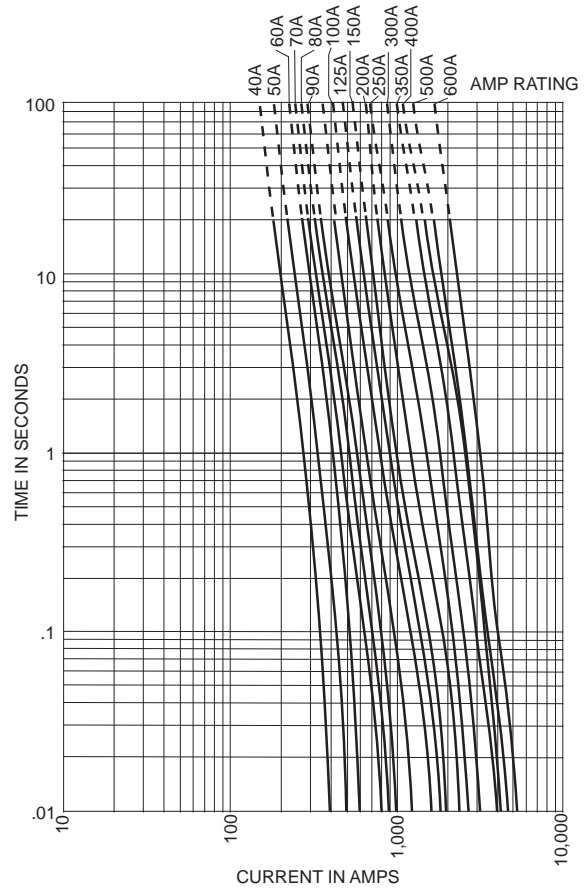

Peak Let-Through Current Curves

E100SF(Amp)
20 – 30A

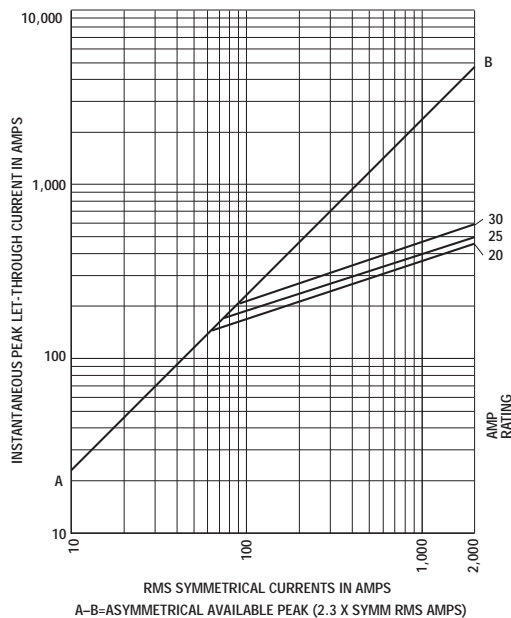

E100S(Amp)
40 – 600A

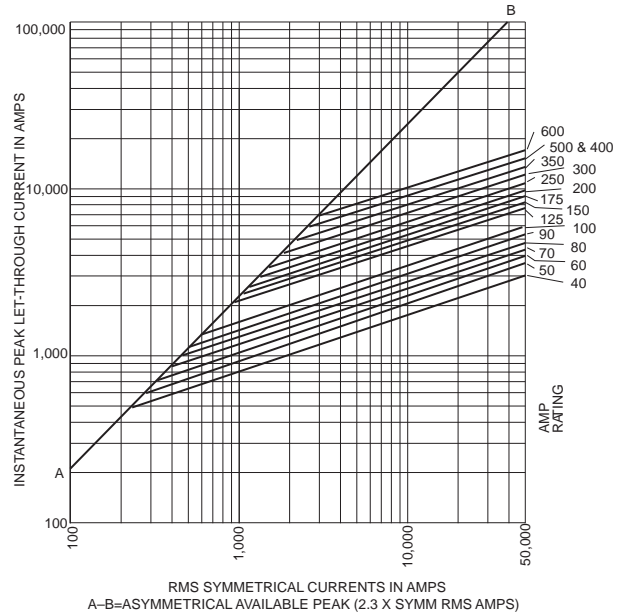



Introduction

British BS 88 Contents

Fuse Volts	Amp Range
240	6-900
690	6-710

Accessories

- Indicator System (see end of this section)
- Fuse Blocks (see BH Series fuse blocks in this catalog)

British BS 88 Fuse Ranges

Amps	Volts	AC	DC
6-900	240	X	—
6-900	150	—	X
6-700	690	X	—
6-700	500	—	X

General Information

Designed and tested to:

- BS 88: Part 4
- IEC 269: Part 4
- UL Recognized

We offer the industry's widest range of British style semiconductor fuses and accessories.

Edison British style products use innovative arc quenching techniques and high grade materials to provide:

- Minimal energy let-through (I^2t)
- Excellent DC performance
- Good surge withstand profile

British style fuses are typically found in equipment manufactured in the United Kingdom or British Commonwealth countries. However, North American manufacturers have begun to specify British style fuses — particularly in UPS applications at 240V or less — to take advantage of their size, performance and cost benefits.

Voltage Rating

All Edison British style fuses are tested to IEC 269: Part 4. This standard requires a test voltage which is 5% higher than the rated voltage. In North America, fuses are required to clear only their rated voltage.

Accessories

Trip-indicator fuses are available for use in parallel with the main fuse. Indicator fuses can be attached to the associated fuse, or mounted separately in panel-mounted fuseclips. In addition, a push-on adapter and microswitch attachment are available, to provide remote indication. The BH Series fuse blocks are also available for most applications.

660Vac Range

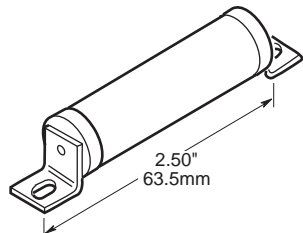
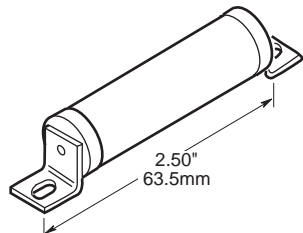
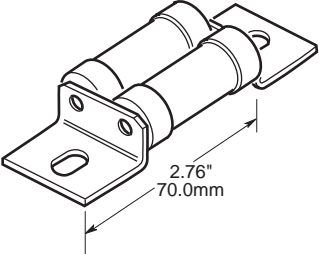
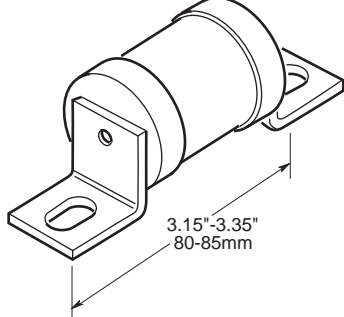
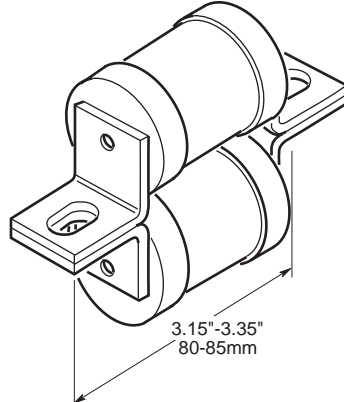
Type	Outline	Part Number	I ² t			Watts Loss	DC Volts	Carton Qty.	Carton Weight (kg)
			Pre-arc	Clearing At 415V	Clearing At 690V				
ET		25ET	25	150	250	7	450	10	0.420
		32ET	32	190	350	11		10	0.420
FE		35FE	33	130	200	9	450	10	0.420
		40FE	52	180	300	9		10	0.420
		45FE	76	270	450	11		10	0.420
		50FE	103	380	600	11		10	0.420
		63FE	135	480	750	12		10	0.420
		71FE	210	600	950	17		10	0.420
		80FE	250	900	1500	20		10	0.420
		90FE	360	1300	2100	20		10	0.420
		100FE	470	1800	2800	23		10	0.420
FEE		100FEE	400	1600	2400	24	450	5	0.450
		120FEE	540	1900	3100	32		5	0.450
		140FEE	850	2500	3800	36		5	0.450
		160FEE	1000	3700	5700	46		5	0.450
		180FEE	1400	5300	8400	46		5	0.450
		200FEE	1900	7100	11400	52		5	0.450
FM		180FM	1400	7500	13500	40	450	1	0.240
		200FM	2600	10500	18500	40		1	0.240
		225FM	3700	14500	26500	44		1	0.240
		250FM	5200	20500	37500	48		1	0.240
		280FM	7000	30500	55000	48		1	0.240
		315FM	10000	40000	77000	55		1	0.240
		350FM	15000	60000	105000	55		1	0.240
		FMM		400FMM	10000	40000		72500	85
450FMM	15000			60000	105000	90	1	0.450	
500FMM	20000			82000	15000	100	1	0.450	
550FMM	30000			120000	215000	100	1	0.450	
630FMM	45000			180000	310000	100	1	0.450	
700FMM	60000			245000	420000	120	1	0.450	

- Interrupting rating 200kA RMS Symmetrical.
- Watts loss provided at rated current.
- These fuses meet the requirements of BS 88 Part 4 and IEC 269-4.
- Consult Edison Customer Satisfaction for UL Recognition information.

UL/CSA Fuses
Current Limiting

UL/CSA Fuses
General Purpose

Special
Purpose Fuses

Canadian
Fuses & Holders

Medium
Voltage Fuses

Fuse Blocks,
Holders & Misc.

Application
Section

240Vac Range

Type	Outline	Part Number	I ² t			Watts Loss	DC Volts	Carton Qty.	Carton Weight (kg)
			Pre-arc	Clearing At 120V	Clearing At 240V				
LCT		6LCT	2	6	9	1.0	200	20	0.110
		10LCT	3.8	12	22	2.5		20	0.110
		12LCT	7	22	32	2.5		20	0.110
		16LCT	20	50	100	2.5		20	0.110
		20LCT	25	80	160	4.0		20	0.110
LET		25LET	18	120	250	4.0	140	10	0.310
		32LET	32	200	450	5.0		10	0.310
		35LET	50	320	600	5.0		10	0.310
		50LET	100	500	1400	7.0		10	0.310
		63LET	180	1100	2200	9.0		10	0.310
		80LET	300	1900	3800	10.0		10	0.310
		100LET	600	3800	7500	10.0		10	0.310
		125LET	600	3800	7500	10.0		10	0.310
		160LET	1100	7000	18000	20.0		10	0.310
		180LET	1600	12000	29000	21.0		10	0.310
LMT		160LMT	1100	7000	16000	17.0	160	1	0.180
		200LMT	1500	10000	20000	28.0		1	0.180
		250LMT	3200	20000	40000	28.0		1	0.180
		315LMT	6000	35000	75000	35.0		1	0.180
		355LMT	8000	50000	100000	35.0		1	0.180
		400LMT	14000	70000	160000	40.0		1	0.180
		450LMT	18000	100000	220000	42.0		1	0.180
LMMT		400LMMT	6000	35000	80000	60.0	160	1	0.370
		400LMMT	14000	80000	170000	64.0		1	0.370
		400LMMT	24000	150000	300000	75.0		1	0.370
		400LMMT	32000	200000	460000	77.0		1	0.370
		400LMMT	52000	300000	600000	82.0		1	0.370
		400LMMT	75000	400000	800000	97.0		1	0.370

- Interrupting rating 200kA RMS Symmetrical.
- Watts loss provided at rated current.
- All fuses above have been tested to 318Vac.
- These fuses meet the requirements of BS 88 Part 4 and IEC 269-4.
- UL Recognition on LET and LMT. Others pending – Consult Edison Customer Satisfaction.

UL/CSA Fuses
Current Limiting

UL/CSA Fuses
General Purpose

Special
Purpose Fuses

Canadian
Fuses & Holders

Medium
Voltage Fuses

Fuse Blocks,
Holders & Misc.

Application
Section

Dimensions - mm

Type	A	B	C	D	E	F	G	H
LCT	47	38	28	8.4	8.7	6.4	4	5.5
FE & ET	77	63.5	48	17.7	19.1	12.7	7.1	9.7
LET	56	41.8	26.2	17.7	19.1	12.7	7.1	9.7
FEE	94	70	46	37	19	31.8	8.7	11.9
FM	113	80-85	50	38	41.5	25.4	10.3	14
LMT	84	59	31	38.1	41	25.4	10.3	13.5
FMM	113	80-85	50	83	38	25.4	10.3	14
LMMT	84	59	31	83	38	25.4	10.3	13.5

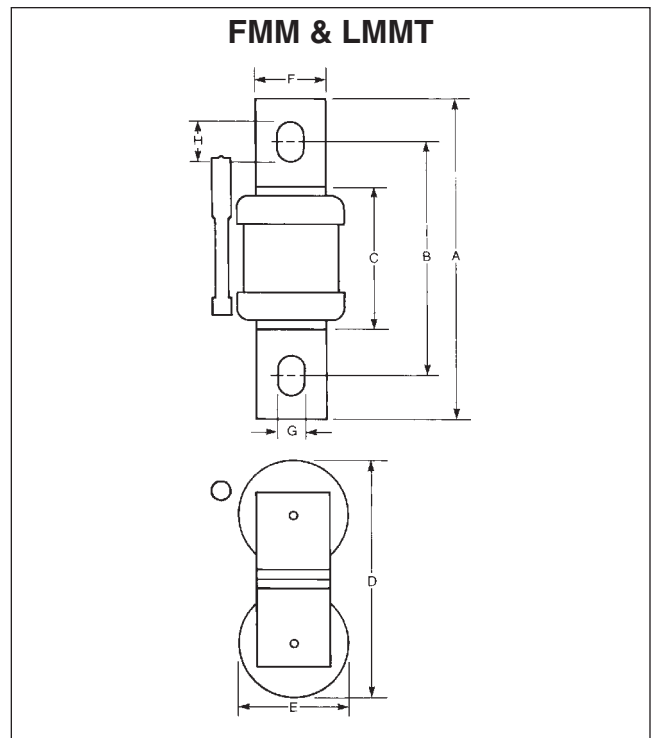
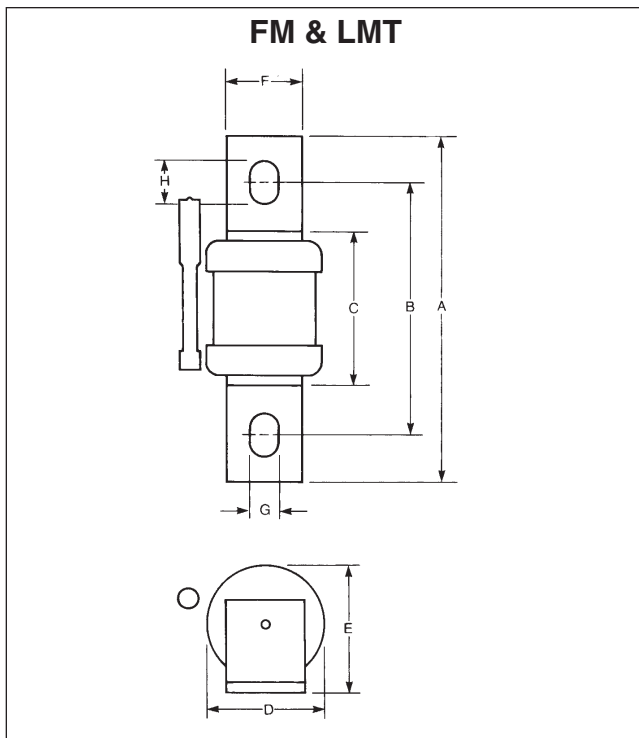
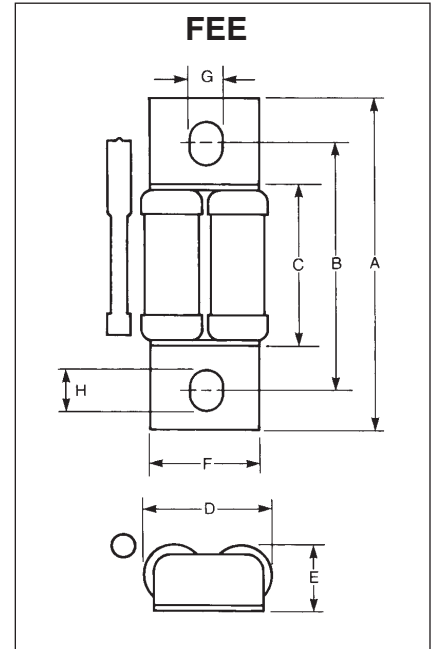
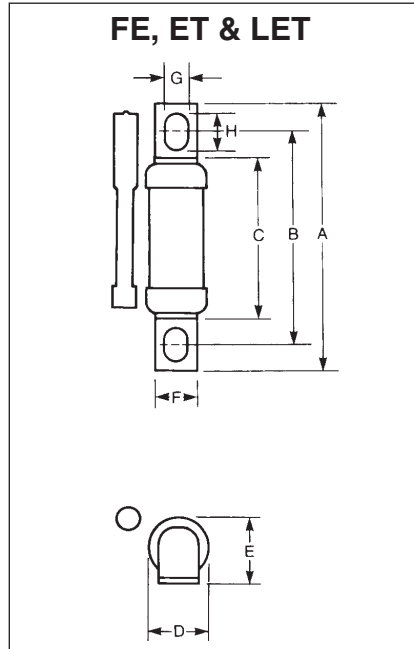
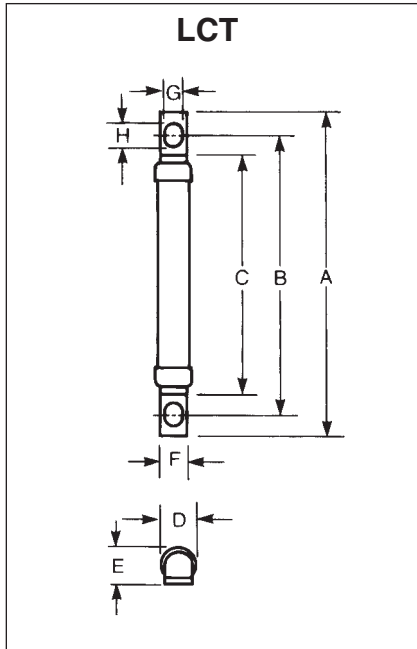

UL/CSA Fuses
Current Limiting

UL/CSA Fuses
General Purpose

Special
Purpose Fuses

Canadian
Fuses & Holders

Medium
Voltage Fuses

Fuse Blocks,
Holders & Misc.

Application
Section

690V Time-Current Curves

FEE (100-200A)
FMM (400-700A)

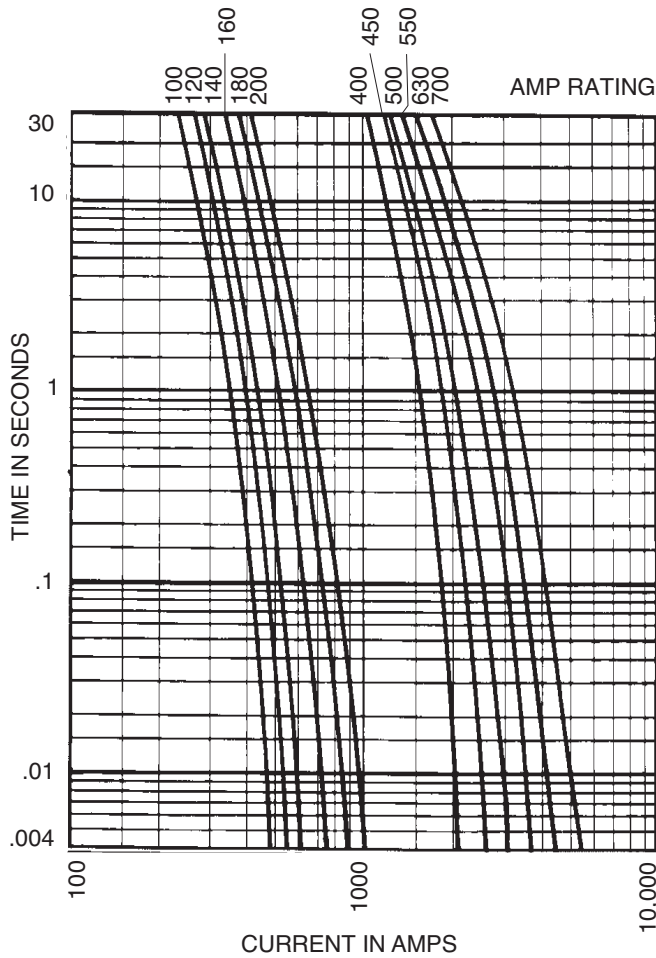

690V Time-Current Curves

FC (6-20A)
FE (35-100A)
FM (180-350A)

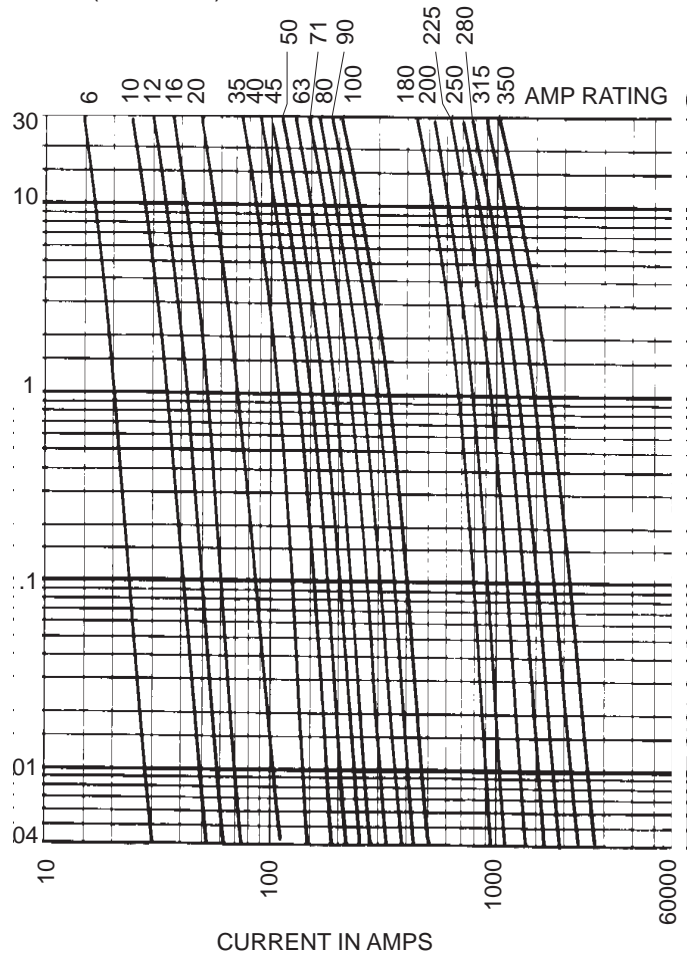

240V Time-Current Curves

LMT (160-450A)

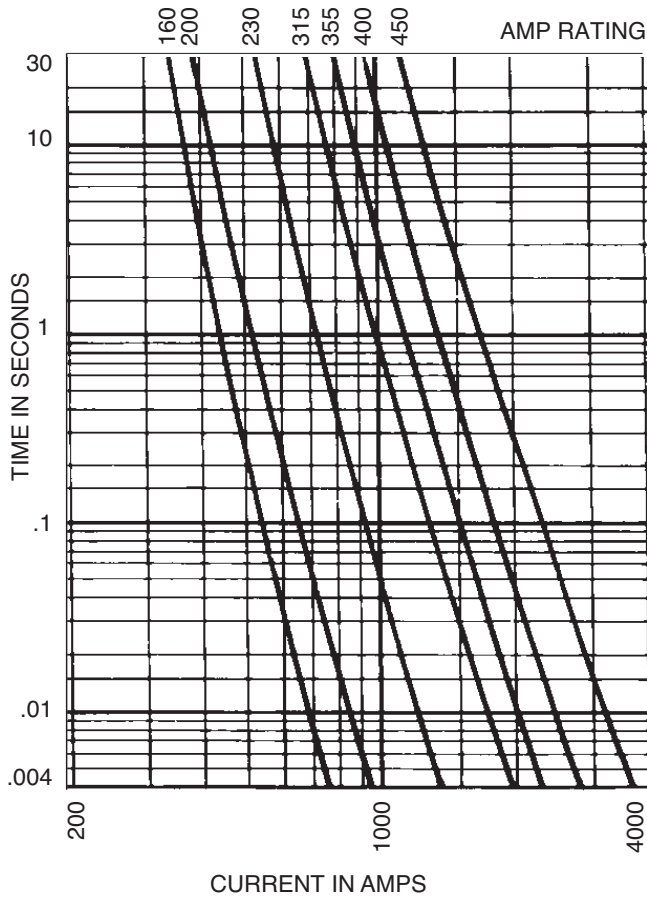

240V Time-Current Curves

LCT (6-20A)
LET (25-180A)
LMMT (400-900A)

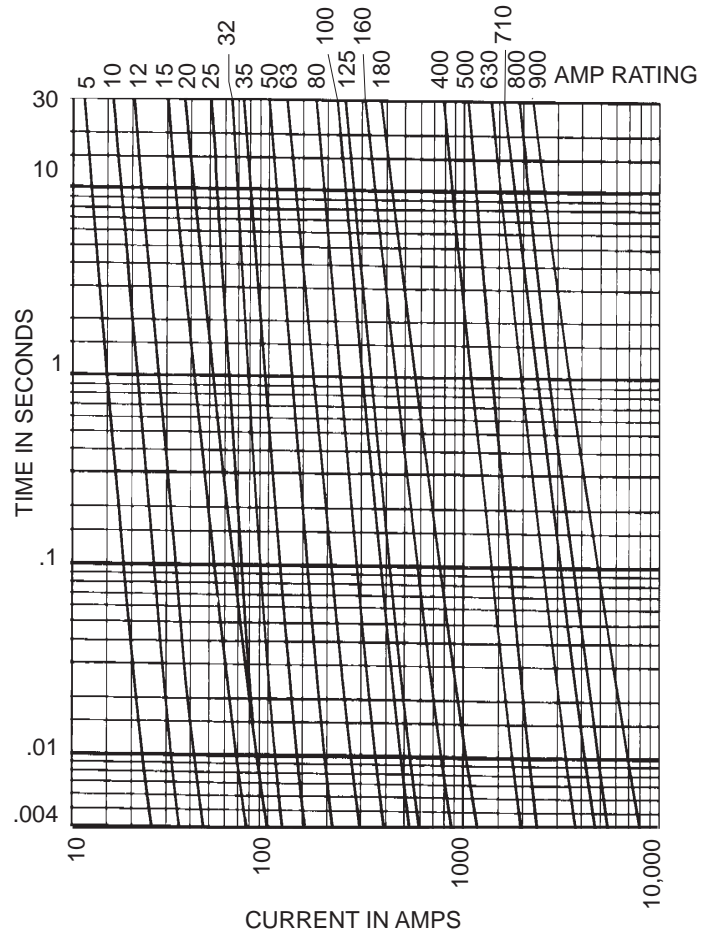

Indicator System

Trip-Indicators

Trip-indicators are available for use in parallel with the main fuse. They can either be attached to the associated fuse or mounted separately in panel mounted fuse clips, reference CL1. A push-on adapter and microswitch attachment is available for use with the trip indicator to give the facility of remote indication, reference MAI.

Fuse ratings of 20A and below cannot usually accommodate a trip-indicator.

When a trip-indicator is to be attached to the main fuse an accessory pack comprising a pair of mounting clips and an appropriate trip indicator would be required. The clips are snapped onto the fuse end caps and the indicator is pressed into clips as shown.

Electrical Specifications

Type	TI500	TI700
Maximum RMS Voltage	500	700
Maximum Peak Voltage	700	1000
Maximum DC Voltage	130	350
Cold Resistance (ohms)	0.3	0.45
Maximum permissible steady-state current	1.5A	1.5A
Interrupting Capacity (RMS Symm.)	100,000	100,000
Pre-Arcing I ² t	23	23

Fuse Indicator Kits

Kit. Ref.	Details	RMS Volts	For use with Fuse Ref.
EC-250	Fuse Mount	250	LET
MC250	Indicator Kits	250	LMT & LMMT
EC-600	(Includes one	660	FE, FEE & ET
MC600	indicator	660	FM & FMM
MC700	and two clips)	700	MT & MMT

CL1 Panel Mount Clips

CL1 Panel mount fuse clips are available for mounting a trip-indicator when mounting directly on the fuse is impractical. Order part number CL1.

Microswitch Adapter – MAI

We offer a microswitch, complete with adapter for securing the indicator. The microswitch is provided with double pole, single throw contacts, having both a normally open and a normally closed position. A special material has been employed in the construction of the adapter to provide reliable operation in the range of temperatures associated with standard operating conditions and during fuse operation.

Microswitch and Adapter Type MAI

Current Rating: AC 50/60Hz resistive load @ 250V RMS AC 50/60Hz resistive load @ 127V RMS	4A 6A
DC, resistive load @ 110Vdc DC, resistive load @ 30Vdc	0.7A DC 2A DC
Maximum Working Voltage: Contact-to-contact (RMS) Contact-to-contact (RMS)	1000V 1500V
Maximum DC Volts:	110Vdc

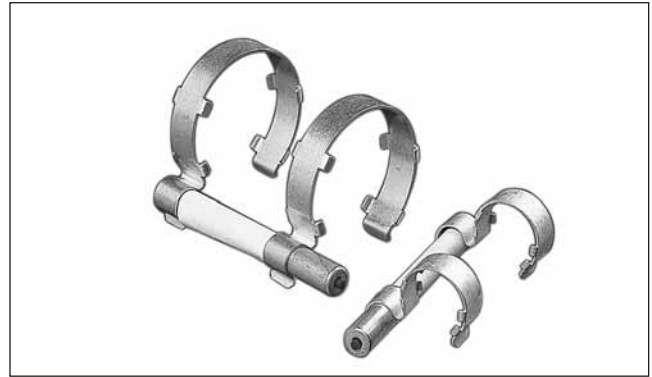

Trip-Indicator Dimensions - mm

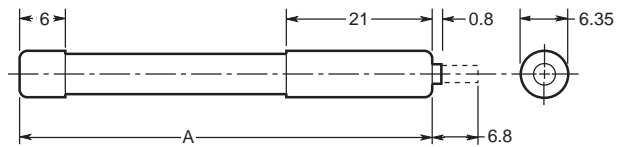

Ref.	Dim. "A" (mm)	RMS Volts
TI250	37.6	250
TI500	47.5	500
TI600	55.7	600
TI700	61.8	700
TI1100	98.4	1100
TI1500	120.6	1500
TI2000	147.5	2000
TI2500	198.3	2500

CL1 Panel Mount Clip Dimensions - mm

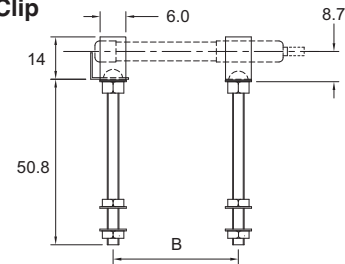

Terminal Arrangement

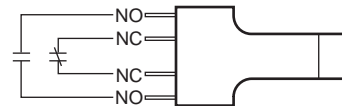

Dimensions in mm

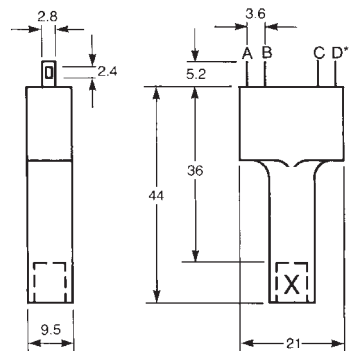

**A+D=N/O contacts
B+C=N/C contacts



Type D "Bottle" Fuse

Amp Ratings: 2 to 100A
Voltage Ratings: 500Vac
Interrupting Rating: 100kA
Agency Approvals:

"D" type fuses complying with DIN 49360 (time lag) 2 and DIN 49515, operating class gG/gL

Catalog Number	Dimension "D"	Ampere Rating	Color Code	Figure Number
2D16	6	2	Pink	1
4D16	6	4	Brown	
6D16	6	6	Green	
10D16	8	10	Red	
16D16	10	16	Gray	
20D16	12	20	Blue	
25D16	14	25	Yellow	2
2D27	6	2	Pink	
4D27	6	4	Brown	
6D27	6	6	Green	
10D27	8	10	Red	
16D27	10	16	Gray	
20D27	12	20	Blue	3
25D27	14	25	Yellow	
35D33	16	35	Black	
50D33	18	50	White	
63D33	20	63	Copper	4
80D125	5	80	Silver	
100D125	7	100	Red	

Additional fuse links: Quick acting fuse links in body size D16, D27, D33 and D125 rated 2-100A. Reference number with suffix "Q", i.e. 10D27Q. Voltage rating 500V ultra fast-acting fuse links in body size D27, D33, and D125 rated 6-100A. Reference number with suffix "R", i.e., 10D27R.

Notes: (a) Gauge rings and keys can also be supplied.

Dimensions - mm

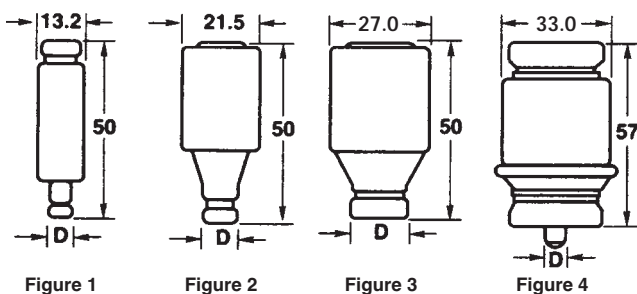

Neozed Fuse

Also suitable for use on 250Vdc systems.
Amp Ratings: 2 to 63A
Voltage Ratings: 400Vac
Interrupting Rating: 100kA

Catalog Number	Dimension "D"	Contact Diameter D ₁	Amp Rating	Color Code
2NZ01	11	7.3	2	Pink
4NZ01	11	7.3	4	Brown
6NZ01	11	7.3	6	Green
10NZ01	11	8.5	10	Red
16NZ01	11	9.7	16	Gray
20NZ02	15	10.9	20	Blue
25NZ02	15	12.1	25	Yellow
35NZ02	15	13.3	35	Black
50NZ02	15	14.5	50	White
63NZ02	15	15.9	63	Copper

Dimensions - mm

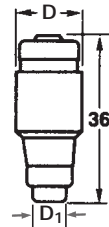

CROSS REFERENCE			
EDISON	LINDNER	SIEMENS	JEAN MULLER
2D16	594-0027	5SA2-11	gTN Dz/2
4D16	594-0047	5SA2-21	gTN Dz/4
6D16	594-0067	5SA2-31	gTN Dz/6
10D16	594-0107	5SA2-51	gTN Dz/10
16D16	594-0167	5SA2-61	gTN Dz/16
20D16	594-0207	5SA2-71	gTN Dz/20
25D16	594-0257	5SA2-81	gTN Dz/25
2D27	597-0027	5SB2-11	gLD 2/2
4D27	597-0047	5SB2-21	gLD 2/4
6D27	597-0067	5SB2-31	gLD 2/6
10D27	597-0107	5SB2-51	gLD 2/10
16D27	597-0167	5SB2-61	gLD 2/16
20D27	597-0207	5SB2-71	gLD 2/20
25D27	597-0257	5SB2-81	gLD 2/25
35D33	598-0357	5SB4-11	gLD 3/35
50D33	598-0357	5SB4-11	gLD 3/35
63D33	598-0357	5SB4-11	gLD 3/35
80D125	595-0807	5SC2-11	gLD 4/80
100D125	595-1007	5SC2-21	gLD 4/100

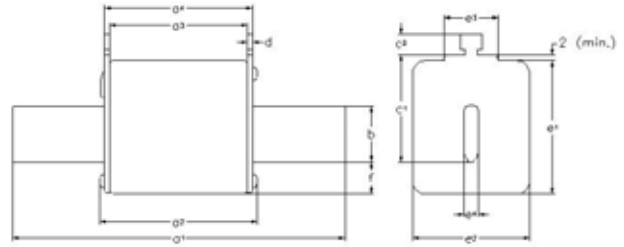

Catalog Number NH

HRC Fuse Links

Class of Operation: gG/gL
Amp Ratings: 2 to 1250A
Voltage Ratings: 500Vac
Sizes: 000 to 4
Standards/Approvals: IEC 60269, VDE0636, DIN 43620 part 1 to 4, VDE mark and CE

Description: A square bodied range of industrial fuse links for a wide variety of applications.

Packaging: 3's, except size 4 packed in 1
Ordering Code: Rating/Type Size Category, e.g., 63NHG000B

Technical Data: Contact Edison Customer Satisfaction for curves and I²t Data.

Rated Voltage: 500Vac
Rated Breaking Capacity: 120kA
Rated Frequency: 50 Hz
Operating Frequency: 45 - 62 Hz

Selectivity: 1 : 1.6 up to 500Vac
Design - Insulator: Ceramic
- Metal Parts: Corrosion-proof (top plate also galvanic plated)
Contact Blades: Full contact and insulated blades available, silver-plated brass.
Protection Type: IP00 according to DIN40050
Dimensions: DIN 43620
Tests: VDE 0636/22
Constancy of Characteristics: Resistant of aging.
On/Off Indicator: Patented spring dual indication
Mechanical Stress: Vibrations 7 up to 50Hz with 1 g, shocks with 5 g.
Environmental: 100% recyclable, RoHS compliant, cadmium and lead free across entire range, corrosion free screws.

Dimensions - mm

Size a	a1	a2 (max)	a3	a4	b (rated)	c1 (±8)	c2 (rated)	D (rated)	e1 (max)	e2 (max)	e3 (max)	e4 (rated)	f (max)
000	78.5±1.5	54	45±1.5	49±1.5	15	35	10	2±0.5	41	21	16	6	8
00	78.5±1.5	54	45±1.5	49±1.5	15	35	11	2±0.5	48	30	25	6	15
0	125±2.5	68	62+3/-1.5	68+1.5/-3	15	35	11	2.5±0.5	48	30	25	6	15
01	135±2.5	75	62±2.5	68±2.5	15	40	11	2.5±0.5	48	30	25	6	15
1	135±2.5	75	62±2.5	68±2.5	20	40	11	2.5±0.5	53	52	25	6	15
02	150±2.5	75	62±2.5	68±2.5	20	48	11	2.5±0.5	53	52	25	6	15
2	150±2.5	75	62±2.5	68±2.5	25	48	11	2.5±0.5	61	60	25	6	15
03	150±2.5	75	62±2.5	68±2.5	25	60	11	2.5±0.5	61	60	25	6	15
3	150±2.5	75	62±2.5	68±2.5	32	60	11	3±0.5	75	70	25	6	18
4	200	84	80	90	50	85	10	3	102	87	-	8	30

Size	Amp Rating	500 gG-gL Dual Indicator Part Number	500 gG-gL Dual Indicator with voltage free metal gripping lugs Part Number
000	2	2NHG000B	2NHG000BI
	4	4NHG000B	4NHG000BI
	6	6NHG000B	6NHG000BI
	10	10NHG000B	10NHG000BI
	16	16NHG000B	16NHG000BI
	20	20NHG000B	20NHG000BI
	25	25NHG000B	25NHG000BI
	32	32NHG000B	32NHG000BI
	35	35NHG000B	35NHG000BI
	40	40NHG000B	40NHG000BI
	50	50NHG000B	50NHG000BI
	63	63NHG000B	63NHG000BI
	80	80NHG000B	80NHG000BI
100	100NHG000B	100NHG000BI	
00	125	125NHG00B	125NHG00BI
	160	160NHG00B	160NHG00BI
0	10	10NHGOB	
	16	16NHGOB	
	20	20NHGOB	
	25	25NHGOB	
	32	32NHGOB	
	35	35NHGOB	
	40	40NHGOB	
	50	50NHGOB	
	63	63NHGOB	
	80	80NHGOB	
	100	100NHGOB	
	125	125NHGOB	
	160	160NHGOB	
01	10	10NHG01B	10NHG01BI
	16	16NHG01B	16NHG01BI
	20	20NHG01B	20NHG01BI
	25	25NHG01B	25NHG01BI
	32	32NHG01B	32NHG01BI
	35	35NHG01B	35NHG01BI
	40	40NHG01B	40NHG01BI
	50	50NHG01B	50NHG01BI
	63	63NHG01B	63NHG01BI
	80	80NHG01B	80NHG01BI
	100	100NHG01B	100NHG01BI
	125	125NHG01B	125NHG01BI
	160	160NHG01B	160NHG01BI
1	200	200NHG1B	200NHG1BI
	224	224NHG1B	224NHG1BI
	250	250NHG1B	250NHG1BI
	315	315NHG1B*	
	355	355NHG1B*	
02	35	35NHG02B	35NHG02BI
	40	40NHG02B	40NHG02BI
	50	50NHG02B	50NHG02BI
	63	63NHG02B	63NHG02BI
	80	80NHG02B	80NHG02BI
	100	100NHG02B	100NHG02BI
	125	125NHG02B	125NHG02BI
	160	160NHG02B	160NHG02BI
	200	200NHG02B	200NHG02BI
	224	224NHG02B	224NHG02BI
250	250NHG02B	250NHG02BI	

Size	Amp Rating	500 gG-gL Dual Indicator Part Number	500 gG-gL Dual Indicator with voltage free metal gripping lugs Part Number
2	315	315NHG2B	315NHG2BI
	355	355NHG2B	355NHG2BI
	400	400NHG2B	400NHG2BI
	425	425NHG2B	
03	250	250NHG03B	250NHG03BI
	315	315NHG03B	315NHG03BI
	355	355NHG03B	355NHG03BI
	400	400NHG03B	400NHG03BI
3	425	425NHG3B	
	500	500NHG3B	500NHG3BI
	630	630NHG3B	
4 Slotted End Tags	500	500NHG4G	
	630	630NHG4G	
	800	800NHG4G	
	1000	1000NHG4G	
	1250	1250NHG4G	

* Denotes 440V

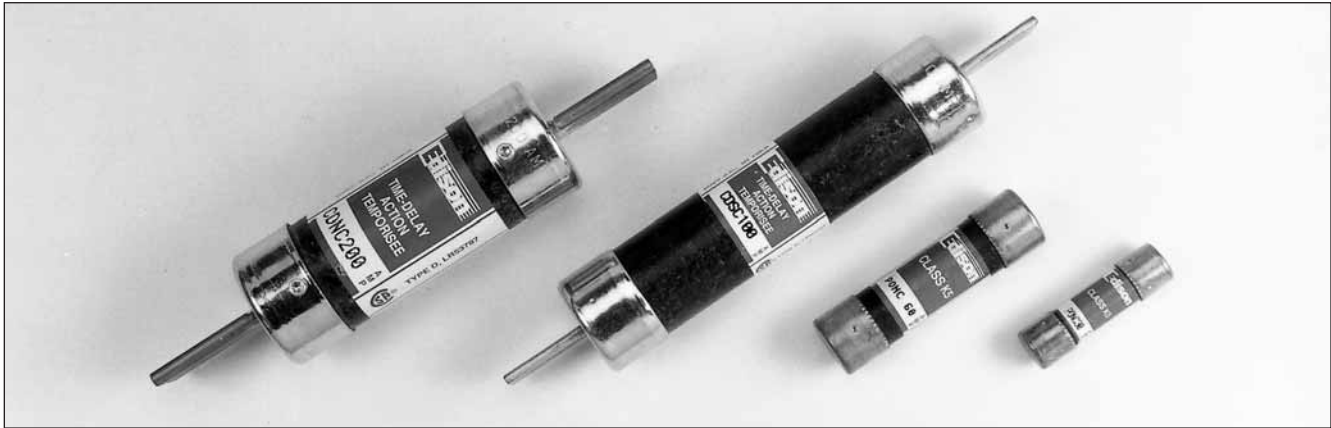

**Standard Dimension Fuses with 10kA Minimum Interrupting Rating;
CSA Certified to C22.2 No. 59.1**

Time-Delay

Volts	Ref.	Amp Ratings	Ctn. Qty.
600Vac	CDSC*	Below 10A use ECSR 10, 12, 15, 20, 25, 30, 35, 40, 45, 50, 60	10
		70, 80, 90, 100	5
		110, 125, 150, 175, 200, 225, 250, 300, 350, 400, 450, 500, 600	1
250Vac	CDNC*	Below 10A use ECNR 10, 12, 15, 20, 25, 30, 35, 40, 45, 50, 60	10
		70, 80, 90, 100	5
		110, 125, 150, 175, 200, 225, 250, 300, 350, 400, 450, 500, 600	1

One-Time

Volts	Ref.	Amp Ratings	Ctn. Qty.
600Vac	KOS**	1, 2, 3, 4, 5, 6, 7, 8, 10, 12, 15, 20, 25, 30, 35, 40, 45, 50, 60	10
		70, 80, 90, 100	5
		110, 125, 150, 175, 200, 225, 250, 300, 350, 400, 450, 500, 600	1
250Vac	KON**	1, 2, 3, 4, 5, 6, 7, 8, 10, 12	10
	PONC***	15, 20, 25, 30, 35, 40, 45, 50, 60 (CSA 'P')	
	KON	70, 80, 90, 100 110, 125, 150, 175, 200, 225, 250, 300, 350, 400, 450, 500, 600	5 1

Dimensions - in (mm)

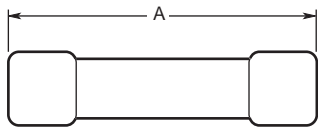

Ferrule Design—1 through 60A

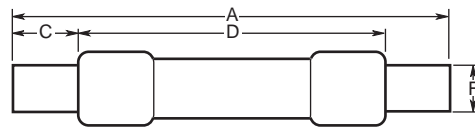

Knife Blade—70 through 600A

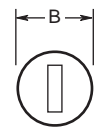

←E

Volts	Catalog Number	Amps	Max. A	Min. B	Min. C	D	E	F
250Vac	CDNC* PONC*** KON*	1-30	2.0 (50.8)	0.56 (14.3)	-	-	-	-
		35-60	3.0 (76.2)	0.81 (20.6)	-	-	-	-
		70-100	5.88 (149.4)	-	1.0 (25.4)	-	0.13 (3.2)	0.75 (19.1)
		110-200	7.3 (185.4)	-	1.38 (34.9)	4.13 (104.8)	0.19 (4.8)	1.13 (28.6)
		225-400	8.63 (219.2)	-	1.88 (47.6)	4.63 (117.5)	0.25 (6.4)	1.63 (41.3)
		450-600	10.38 (263.7)	-	2.25 (57.2)	5.19 (131.8)	0.25 (6.4)	2 (50.8)
600Vac	CDSC* KOS*	1-30	5.0 (127.0)	0.81 (20.6)	-	-	-	-
		35-60	5.5 (139.7)	1.06 (27.0)	-	-	-	-
		70-100	7.88 (200.2)	-	1.0 (25.4)	-	0.13 (3.2)	0.75 (19.1)
		110-200	9.63 (244.6)	-	1.38 (34.9)	6.13 (115.6)	0.19 (4.8)	1.13 (28.6)
		225-400	11.63 (295.4)	-	1.88 (47.6)	7.13 (118.1)	0.25 (6.4)	1.63 (41.3)
		450-600	13.38 (339.9)	-	2.25 (57.2)	8.19 (208.0)	0.25 (6.4)	2 (50.8)

*CDSC & CDNC are CSA certified Type "D".

** KON 1-12A and KOS 1-60A are not CSA Certified.

*** PONC are CSA certified Type "P".

Average Time-Current Curves

Cat. No. KON/PONC 250Vac

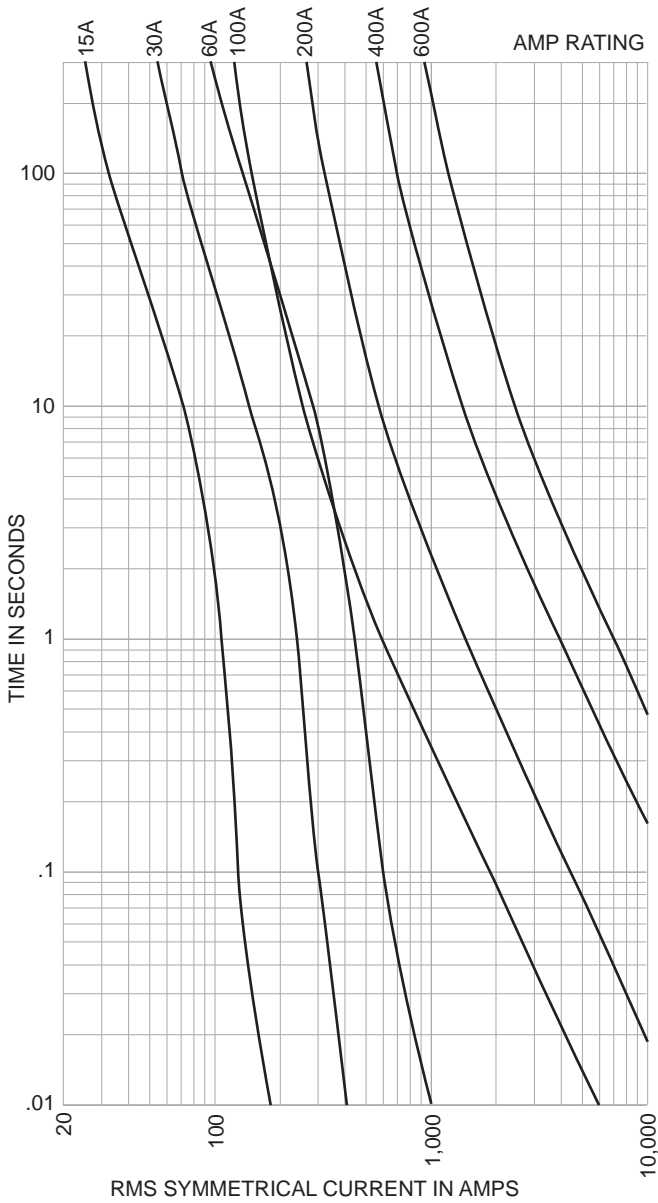

Cat. No. KOS 600Vac

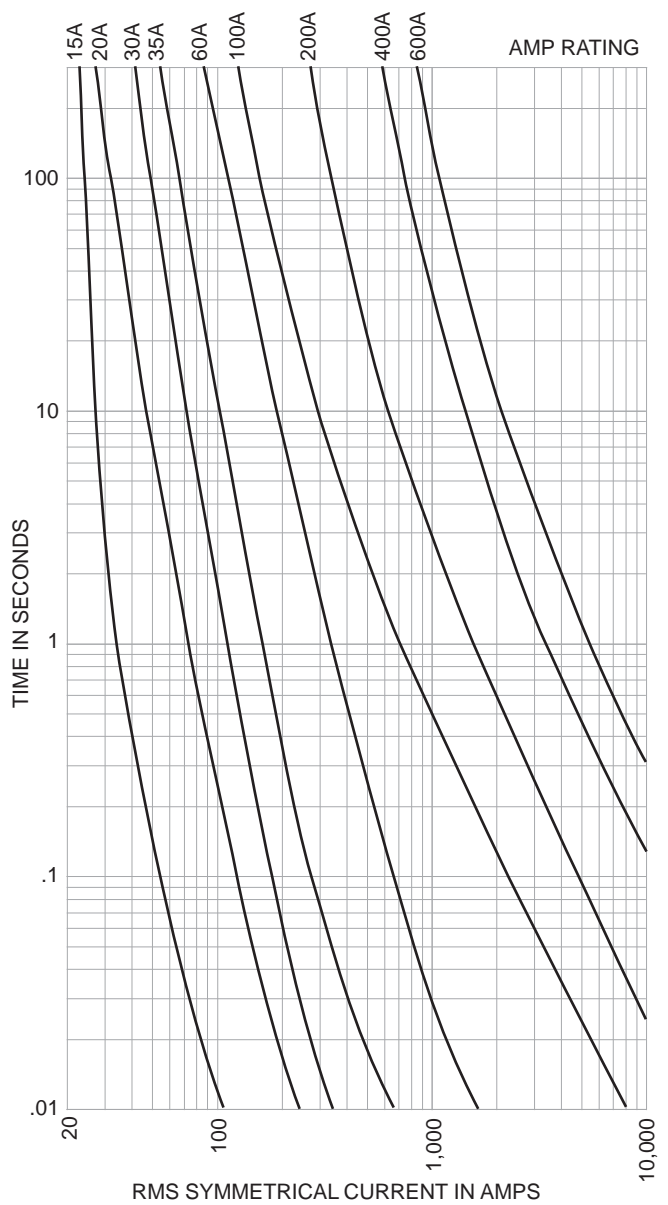

Average Time-Current Curves

Cat. No. CDNC 250Vac

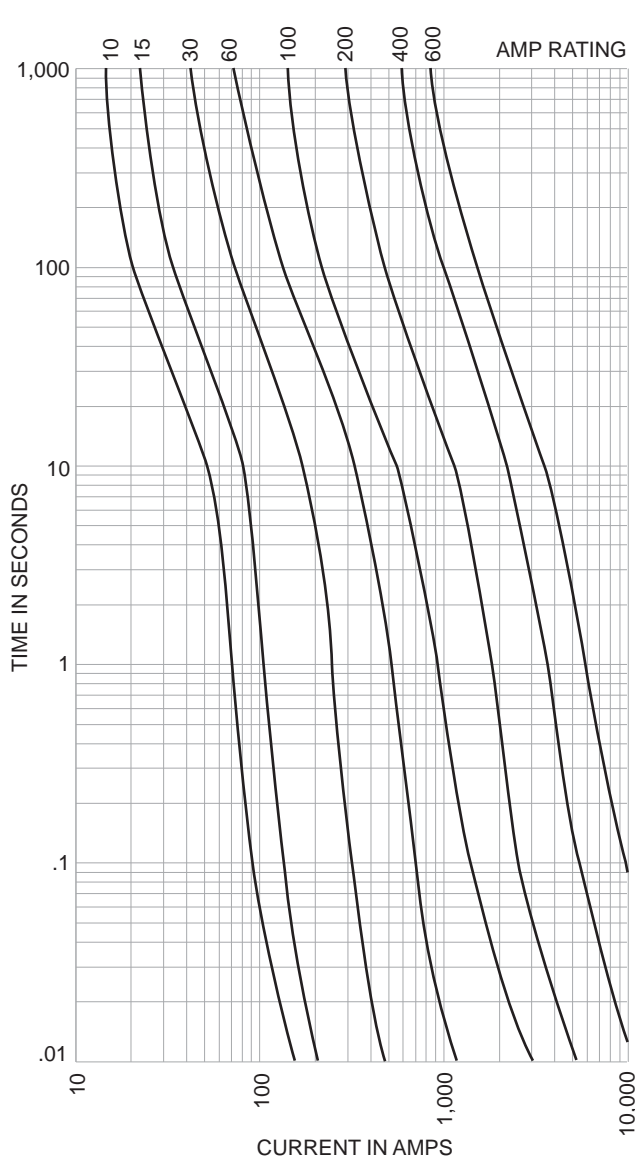

Cat. No. CDSC 600Vac

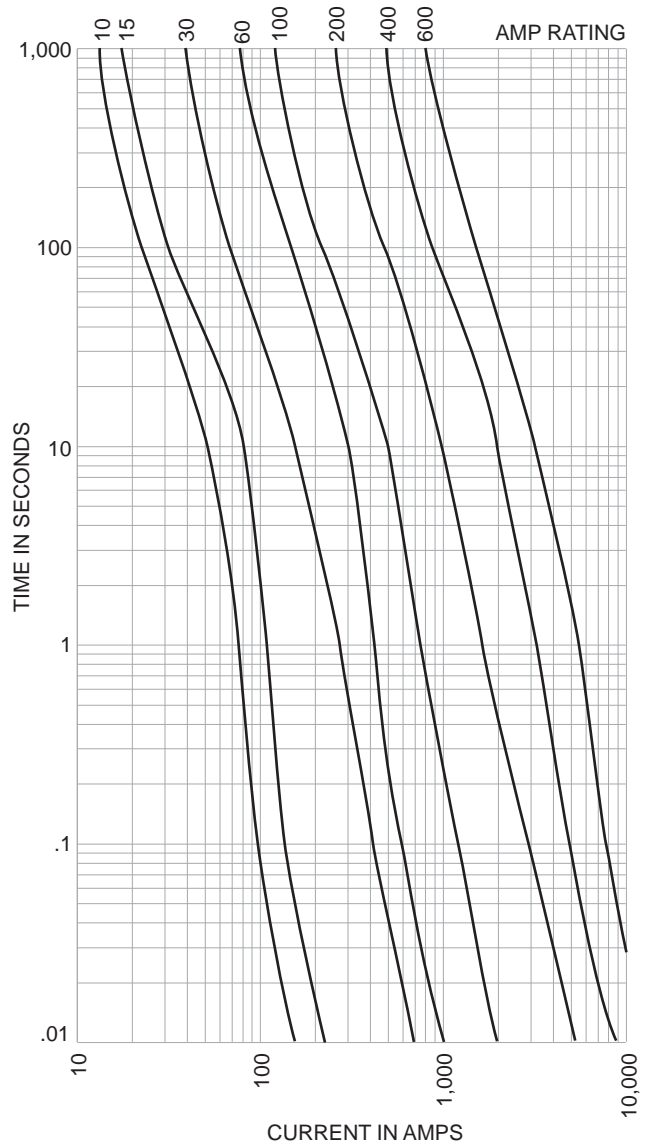



Figure 1

Range: 30 (miniature), 30, 60, and 100A, 600Vac

A range of fully shrouded HRC fuse holders having an advanced design. They incorporate a high level of innovation, with enhanced performance characteristics and comply with the requirements of: CSA C22.2 No. 39 as well as IEC 60269 and BS88 Standards.

Unique Cam Action

The fuse carriers are fitted with a cam for ease of removal from the fuse bases allowing significantly improved contact pressure between fuse carrier and fuse base contacts, with a corresponding enhanced electrical performance level. This design overcomes a major problem of all existing dead front style fuse holders manufactured worldwide, which have to compromise between difficulties of fuse carrier removal from base and contact pressure achieved.

Lockable Safety Carriers

A range of lockable safety carriers for the CAMaster fuse holder (Cat ref: LSC), are available. This distinct feature ensures isolation can be achieved allowing maintenance to be carried out in safety.

Fixing Torque and Cable Size

Ref	Fuse Fixing Tightening Torques	Max Cable Size
CM20CF	1.5N•m	#2
CM30CF	1.5N•m	#2
CM60CF	2.0N•m	2/0
CM100CF	2.0N•m	2/0

Catalog Numbers

Amps	Mounting	Edison Catalog Numbers
30	Front	CM20CF
	Front/2-pole	2xCM20CF + GLP
	Back	CM20CF + 2 off 20BS
	Front/Back	CM20CF _ 1 off 20BS
30	Front	CM30CF
	Back	CM30CF + 2 off 30BS
	Front/Back	CM30CF + 1 off 30BS
60	Front	CM60CF
	Back	CM60CF + 2 of 60/100BS
	Front/Back	CM60CF + 1 of 60/100BS
100*	Front	CM100CF
	Back	CM100CF + 2 of 60/100BS
	Front/Back	CM100CF + 1 or 60/100BS

*Uses compact Edison fuses.

CAMaster Ratings

Rating	Details	Reference	Fuse Accommodated
30 Amp	For HRCI-CA Applications	CM20CF	--CIF21
30 Amp 60 Amp 100 Amp	For HRCII Applications	CM30CF CM60CF CM100CF	---H07C ---K07C ---K07CR

Accessories for CAMaster Units

Rating	Details	Reference	Fuse Accommodated
30 Amp 30 Amp 60/100 Amp	Back Stud	20BS 30BS 60/100BS	For CM20CF For CM30CF For CM60/100CF
All	Ganging Link Kit	GLP	For 3 Pole
All	660V Neon Indicator	NI-660	-
30 Amp 30 Amp 60/100 Amp All	Security Carrier with Clip. Clip Only	20LSC 30LSC 60/100LSC CMCS	For CM20CF For CM30CF For CM60/100CF For all sizes
30 Amp 30 Amp 60/100 Amp	Solid Link	20CML 32CML 63/100 CML	For CM20CF For CM30CF For CM60/100CF

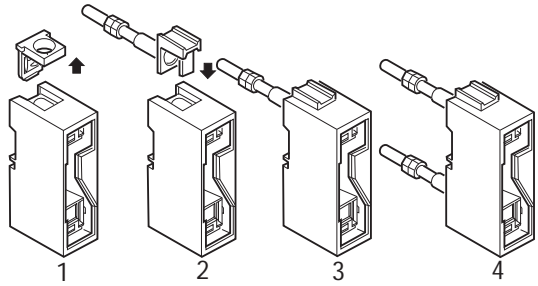

Figure 2. Unique Conversion Capability

Unique Conversion Capability

The standard fuse holders can be readily converted from front connection to front/back stud and double-back stud connection types at the point of use. This is achieved with a unique back stud accessory and the use of a screwdriver. See conversion sequence in Fig. 2. Steps 1, 2 and 3 show removal of ferrule end and insertion of back stud accessory to give the front/back stud connection type. This sequence repeated at the opposite end gives the double-back stud connection type shown in step 4.

Unique Cable Termination

The fuse holder's unique cable terminations are designed for user convenience and to ensure long-term reliability. They incorporate stainless steel saddles and hardened termination screws, maintaining permanent cable clamping to profiled contact plates. The main electrical contact path between the cable and fuse link tag is shown highlighted. This permits the use of high tightening torques without damage to cables or threads and provides resistance to high cable pull out forces. (See Fig. 3.) The fuse holders are supplied with the hardened termination screws backed out ready for cable insertion, saving installation time.

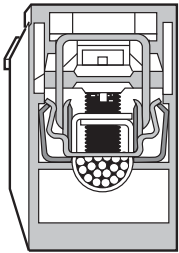

Figure 3. Unique Cable Termination

Hinged Captive Screws

The fuse fixing screws to fuse carrier are held in captive hinges providing ease of fixing and preventing loss during installation. (See Fig. 4.)

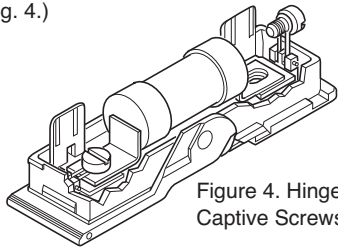

Figure 4. Hinged Captive Screws

Two/Three Pole Ganging

The unique design of the carriers allows ganging to be readily achieved by the use of standard accessories. This provides improved safety related to isolation and protection of 2-Pole and 3-Pole electrical circuits by ensuring that the correctly related poles are removed at the same time. (See Fig. 5.)

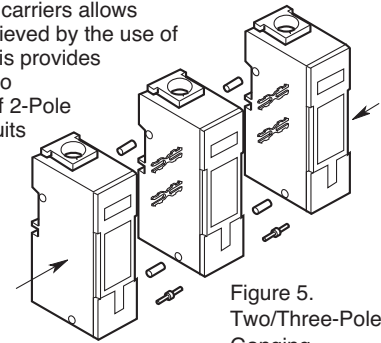

Figure 5. Two/Three-Pole Ganging.

Dual Mounting Capability

The design as standard provides both bolted panel and DIN rail mounting features. The DIN rail mounting facility for each of the various dimensioned ratings is so designed as to give equal height and depth above the DIN rail.

Hinged Internal Shields

Non-removable full shrouding of live parts within the fuse base is provided by the use of hinged shields. The positive captive nature of these ensures that they cannot be omitted during installation and are so designed that insertion of the fuse carrier can only be made with them correctly positioned.

Neon Indicator

Neon clip-in indicator accessories are available providing clear location and status of fuses which have opened. (See Fig. 6.)

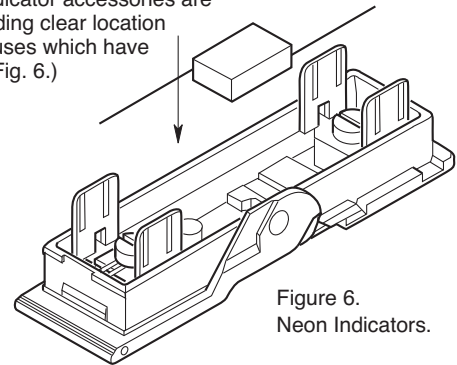

Figure 6. Neon Indicators.

Circuit Identification

The fuse carrier has a marking label for ease of circuit identification.

Strip Length Marking

The length of cable insulation that should be stripped off is shown on the side of the fuse base.

Cross Reference

Amps	Mounting	Edison	Old Brush		GEC	Fusetek
30	Front	CM20CF	CIF15F	CIF15A	CRS15H	MF20F
	Front/2-pole	2xCM20CF + GLP	-	-	C2RS15H	-
	Back	CM20CF + 2 off 20BS	CIF15BS	CIF15B	-	-
	Front/Back	CM20CF + 1 off 20BS	CIF15FBS	CIF15C	-	-
30	Front	CM30CF	C30AF	CCH30A	C30H or CRS30H	MF30F
	Back	CM30CF + 2 off 30BS	C20ABS	CCH30B	C30P	MF30B
	Front/Back	CM30CF + 1 off 30BS	C30AFBS	CCH30C	C30PH	MF30FB
60	Front	CM60CF	C60BF	CCK60A	C60H or CRS60H	MF60F
	Back	CM60CF + 2 of 60/100BS	C60BBS	CCK60B	C60P	MF60B
	Front/Back	CM60CF + 1 of 60/100BS	C60FBS	CCK60C	C60PH	MF60FB
100*	Front	CM100CF	C100CF	CCL100A	C100H or CRS100H	MF100F
	Back	CM100CF + 2 of 60/100BS	C100CBS	CCL100B	C100P	MF100B
	Front/Back	CM100CF + 1 or 60/100BS	C100CFBS	CCL100C	C100PH	MF100FB

*Edison uses compact fuse.

Dimensions - in (mm)

Standard Front Connected Unit

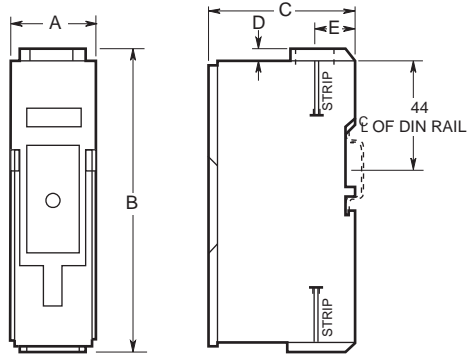

Front/Back Stud and Double Back Stud
Connected Units

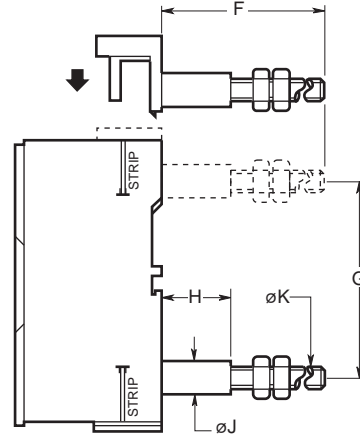

Rating Amps	Catalog Number	Category	Dimensions - in (mm)									
			A	B	C	D	E	F	G	H	J	K
30	CM20CF	HRCI-CA	1.0 (25.4)	3.69 (93.7)	2.36 (60)	0.13 (3.2)	0.64 (17.5)	2.60 (66)	2.29 (58)	1.13 (28.6)	0.47 (11.9)	M6
30	CM30CF	HRCII-C	1.25 (31.8)	4.63 (117.5)	2.36 (60)	0.13 (3.2)	0.69 (17.5)	2.60 (66)	2.92 (74)	1.13 (28.6)	0.47 (11.9)	M6
60	CM60CF	HRCII-C	1.40 (35.6)	4.93 (125)	2.36 (60)	0.19 (4.75)	0.65 (16.4)	3.41 (86.5)	3.14 (79.8)	1.13 (28.6)	0.47 (11.9)	M8
100	CM100CF	HRCII-MISC	1.40 (35.6)	4.93 (125)	2.36 (60)	0.19 (4.75)	0.65 (16.4)	3.41 (86.5)	3.14 (79.8)	1.13 (28.6)	0.47 (11.9)	M8

Panel Drilling Plans, Viewed from Front of Panel

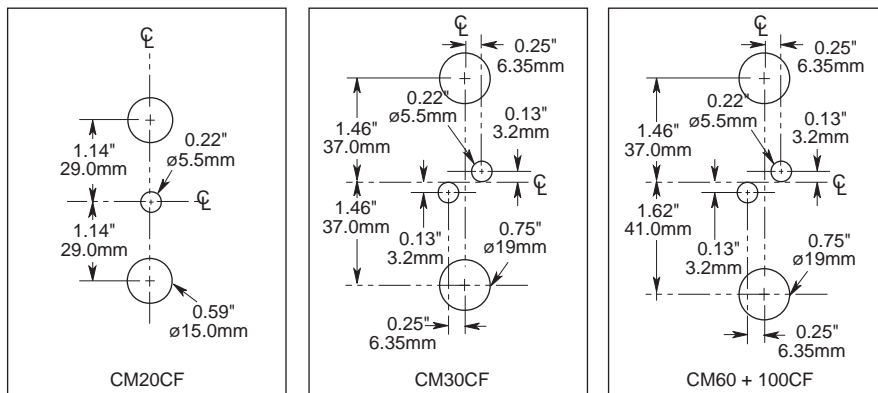

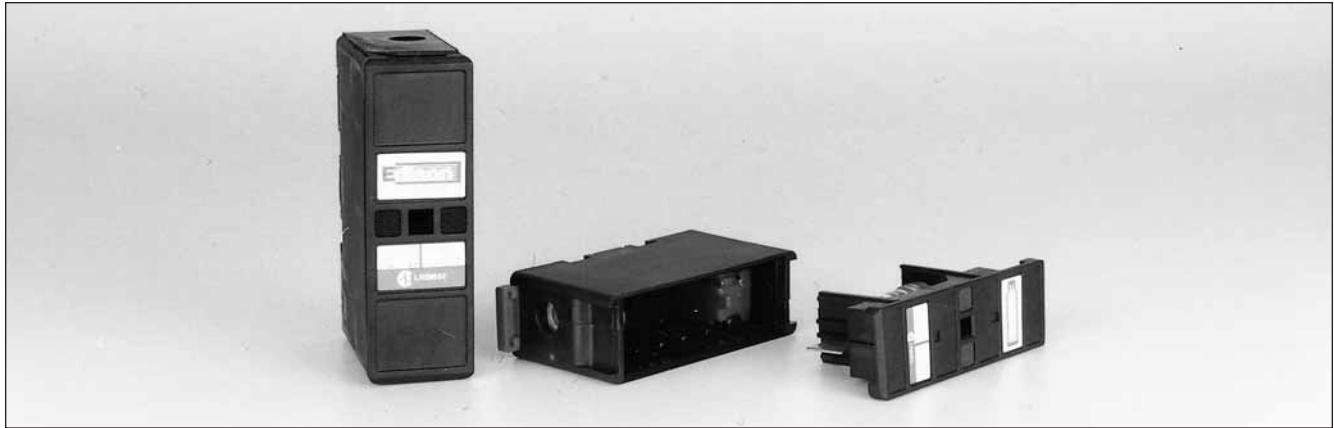

For use with HRCI-CB Fuses. Suitable for Bolted Panel Mounting or DIN-Rail Mounting.

Description

SAFE_{LOC} fuse holders provide a simple range designed to accommodate the compact range of offset blade fuse to CSA C22.2 No. 106, HRCI-CB. The combination offers significant savings in volume and cost as well as a reduction in fitting time and power loss.

Features

The fuse holders incorporate a unique slide/snap action carrier which eliminates the need for fuse carrier contacts. This provides positive, stress free fitting of fuse and locks the fuse in position ensuring safe insertion and withdrawal from the base. The resulting direct contact between fuse blades and the plated base contacts provides lower watts loss and increased reliability. The base contacts are fully shrouded to protect personnel from direct contact electric shock. The shrouds utilize simple slide/snap action allowing access to the contact terminal screws. They are semi-captive within the base, reducing the risk of loss during cabling. The fuse base, which consists of glass filled, high impact resistant thermoplastic polyester, incorporates a direct 35mm DIN rail mounting facility as well as single screw fixing.

Tightening Torque

To avoid a heat build up it is most important the cable terminal screws are screwed in tight and are holding the cable firmly. A tightening torque of 2.5 to 2.8 Newton meters (N·m) or 22 to 25lb-in is recommended.

Catalog Numbers

For use with HRCI-CB Fuses			
Rating	Connection	Edison Catalog Numbers	Fuse Accommodated
30 Amp	Front	C30F	CIF06
	Back	C30BS	
	Front-Back	C30FBS	
60 Amp	Front	C60F	EK
	Back	C60BS	
	Front-Back	C60FBS	

SAFE_{LOC} fuse holders provide an easy method of protecting a wide range of electrical equipment such as lighting, heating, motor and control equipment circuits, and offer significant savings on volume, cost, fitting time and power loss.

Cross Reference

Amps	Mounting	Edison	GEC	FUSETEK
30	Front	C30F	CSC30H	MD30F
	Back	C30BS	CSC30P	MD30B
	Front/Back	C30FBS	-	MD30FB
60	Front	C60F	CSC60H	-
	Back	C60BS	-	-
	Front/Back	C60FBS	-	-

Dimensions - in (mm)

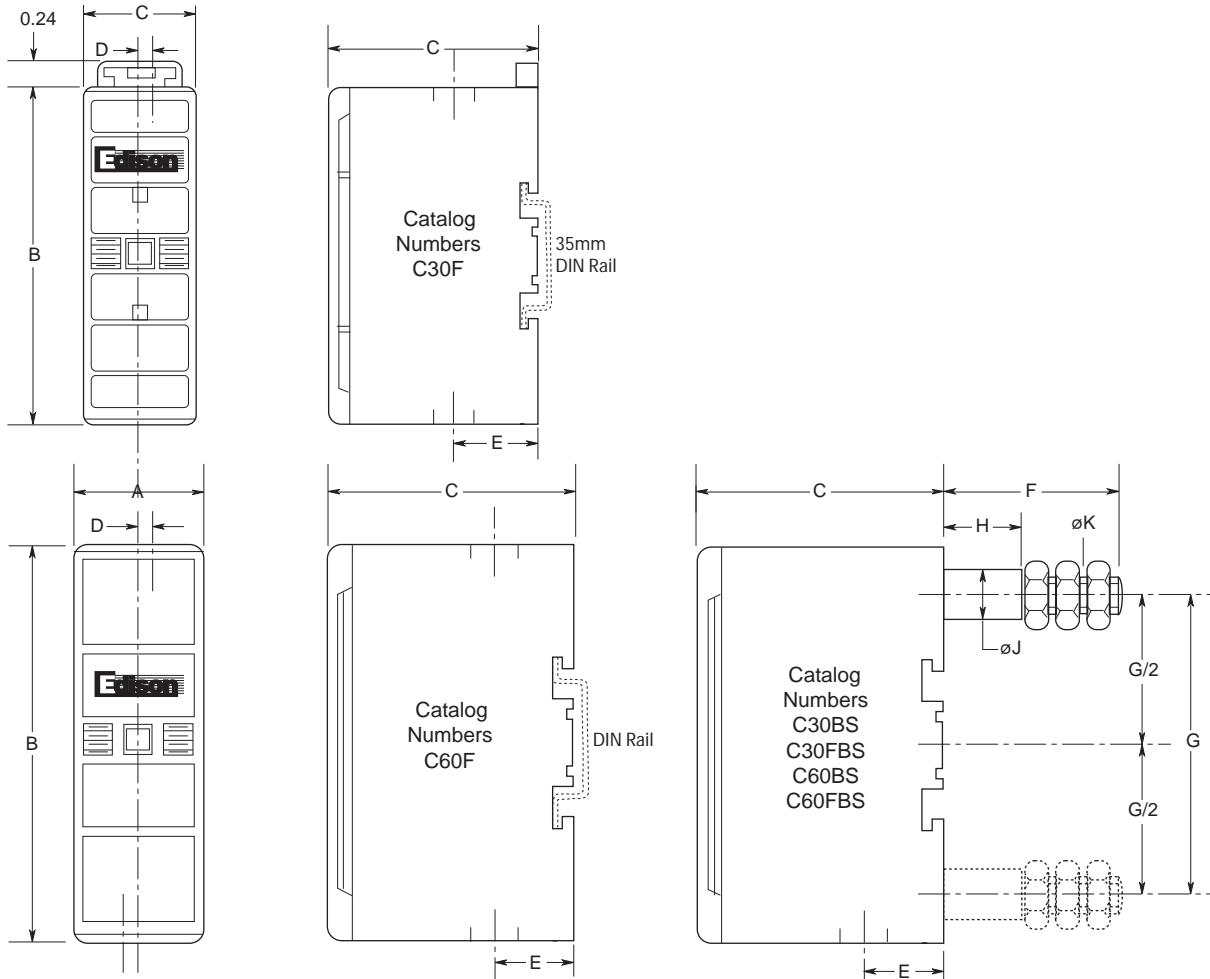

Dimensions - in (mm)

Amps	Series Number	Max. Cable mm ²	A	B	C	D	E	F	G	H	J	K
30	C30	16	1.0 (25.4)	3.0 (76.2)	1.83 (46.5)	0.09 (2.3)	0.63 (16.0)	1.54 (39.2)	2.27 (57.7)	0.67 (17.0)	0.38 (9.7)	M6
60	C60	35	1.15 (29.1)	3.55 (90.0)	2.18 (55.0)	0.13 (3.3)	0.70 (17.7)	1.54 (39.2)	2.68 (67.9)	0.69 (17.5)	0.43 (11.0)	M8

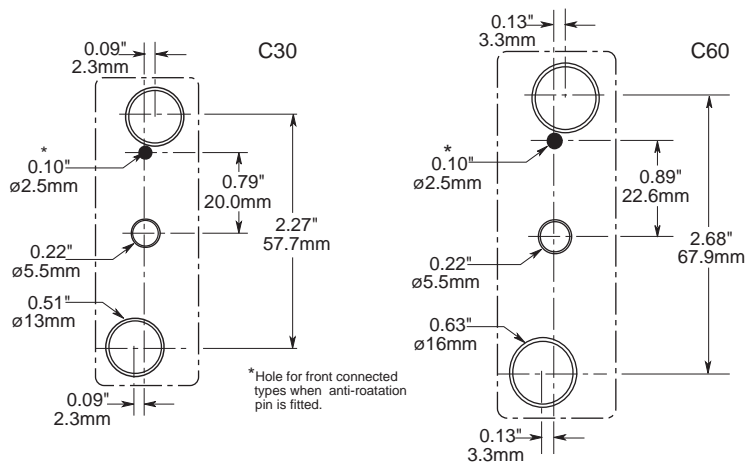

Medium voltage fuses for motor circuits offer the following user benefits:

- Performance complies with latest ANSI Standards
- Dramatic reduction in energy let-through
- Lower power dissipation
- Low arc voltage during operation
- Includes heavy duty striker to IEC 282-1

Advantages of Edison Motor Fuses

During the full voltage starting of motors the fuse elements reach a considerably higher temperature than normally occurs under continuous operation. The resulting expansion and contraction of the fuse element can cause premature operation. The Edison motor circuit fuse incorporates provisions in the design of the element to minimize this effect and hence avoid the necessity of having to use a much larger size of fuse.

Edison fuses operate very quickly on heavy fault currents. This results from the steepness of the time-current characteristic, which also facilitates coordination with the other components of the circuit.

Lower power dissipation helps to ensure low temperature rise of, for example, multi-tier starters.

Switching (arc) voltages are appreciably less than permitted values and fall with lower values of system voltage. Thus, the 5.5kV fuses are equally suitable for use in 4.8kV, 4.16kV and 2.4kV circuits.

The superior low-overcurrent breaking performance is of advantage whether or not the striker is used to open the contactor.

“R” Rating

The R-Rated motor circuit fuses should be selected to coordinate with the motor and controller to provide short-circuit protection.

The actual “R” rating signifies a 20 second opening time at 100 times the “R” rating of the fuse.

For example:

2R fuse opens in 20 seconds at 200A.

12R fuse opens in 20 seconds at 1200A.

Motor Starting Application

Application Procedure

For any motor the fuse current rating is determined by magnitude and duration of starting current, except in a few situations where the starting conditions are very light. The fuse current rating should be selected as follows.

Direct On-Line Starting

In the absence of specific information the starting current can usually be taken to be six times the motor full load current. The starting time will depend on the type of drive but will be approximately as follows:

- Pump Motors - 6 seconds
- Mill Motors - 10 to 15 seconds
- Fan Motors - 60 seconds

These are average values and the appropriate figures for starting current and starting time for the actual installation should be obtained wherever possible. Multiply the starting current by 1.6 and using this value of current and the starting time (it is recommended that a minimum time of 8 seconds be adopted) plot this point on the minimum melting time-current characteristics of the fuses. The correct current rating of fuse is then chosen as being the one immediately to the right of the point so plotted. The chosen fuse must also have a current rating of at least 1.3 times the full-load current of the associated motor.

The rating thus chosen will be adequate for normal applications where the associated motor is not started more than twice in any given period of one hour. For applications involving more frequent starting duties, a greater derating factor must be applied as shown in the following table.

Derating Factor

Maximum of starts per hour	Derating factor
2	1.6
4	1.7
8	2.0
16	2.2

The figures in the above table apply only when the Minimum Melting Time-Current Characteristic Curve is used.

For applications involving more frequent starting duty than 16 times per hour or where unusual duty cycles are involved consult Edison Customer Satisfaction for advice.

Assisted Starting

A similar method of fuse selection may be used as for direct-on-line starting (see above) but it must be noted that the normal running current of the motor is likely to be closer in value to the nominal current rating of the fuse than for direct-on-line applications.

The rating of fuse chosen will need to be appreciably greater than the motor running current to allow for restricted cooling inside control gear cubicles, particularly where multi-tier starters are involved. In case of doubt refer to Edison Customer Satisfaction for further guidance.



Medium Voltage R-Rated Fuses for 2.4 and 4.8kV Motors

List of Ratings

2.4kV System Voltage		
Catalog Symbol	Current Rating Amps at 40°C	Figure Number
2.75 VFRHA 2R	70	1
2.75 VFRHA 3R	100	
2.75 VFRHA 4R	130	
2.75 VFRHA 6R	170	
2.75 VKRHA 9R	200	
2.75 VKRHA 12R	230	
2.75 VKRHK 18R	390	2
2.75 VKRHK 24R	450	
4.8kV System Voltage		
5.5 VFNHA 2R	70	3
5.5 VFNHA 3R	100	
5.5 VFNHA 4R	130	
5.5 VFNHA 6R	170	
5.5 VKNHA 9R	200	
5.5 VKNHA 12R	230	
5.5 VKNHK 18R	390	4
5.5 VKNHK 24R	450	
5.5 VKNHK 30R	450	
5.5 VKNHK 36R	500	
5.5 VKNHK 40R	600	
5.5 VKNHK 48R	650	

Dimensions - in (mm)

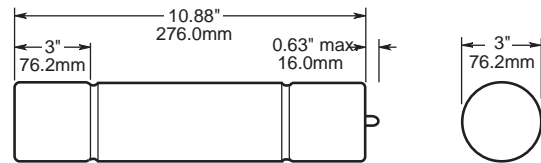

Figure 1

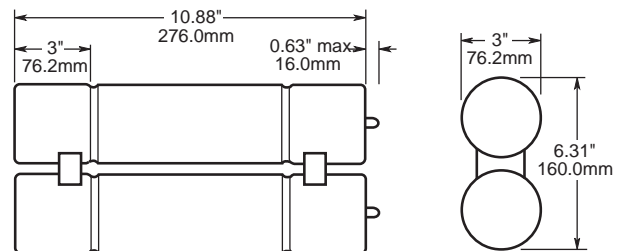

Figure 2

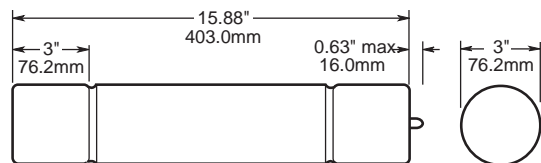

Figure 3

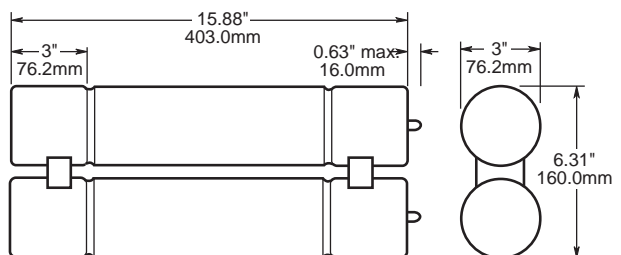

Figure 4

Notes:

1. Interrupting rating - 80,000 amps asymmetrical 60Hz.
2. These fuses are dimensionally interchangeable with corresponding R-Rated fuses produced by other leading North American manufacturers.

Time-Current Characteristics for 5.5kV and 2.75kV Fuses

Total Clear

Minimum Melt

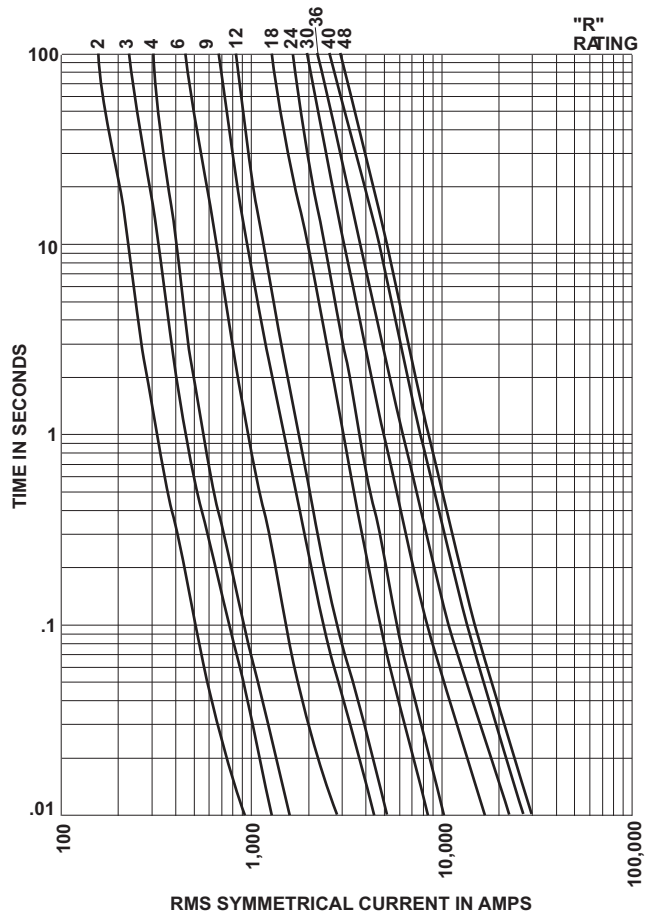
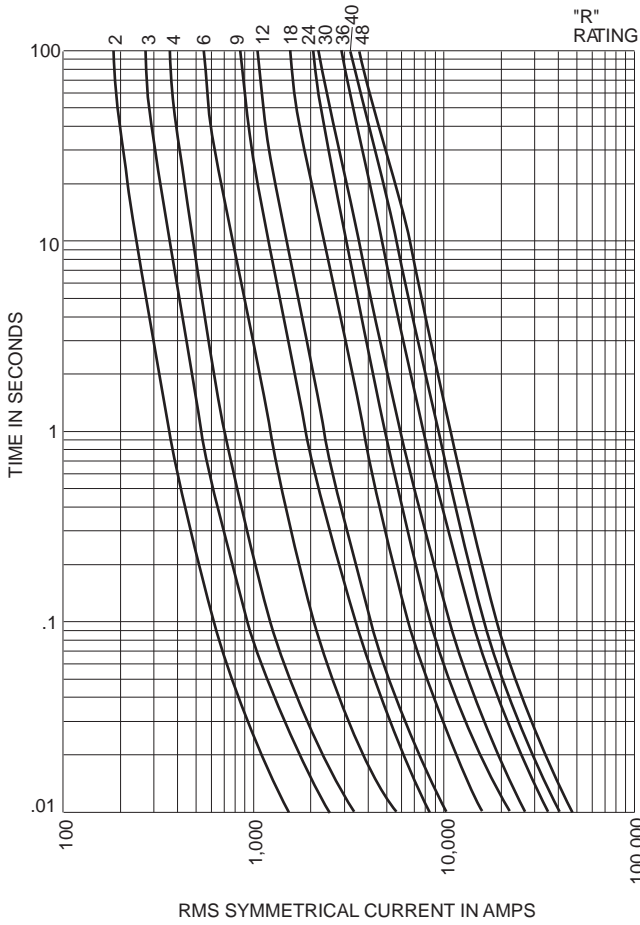

UL/CSA Fuses
Current Limiting

UL/CSA Fuses
General Purpose

Special
Purpose Fuses

Canadian
Fuses & Holders

Medium
Voltage Fuses

Fuse Blocks,
Holders & Misc.

Application
Section

Peak Let-Through Current Curve (5.5kV and 2.75kV Fuses)

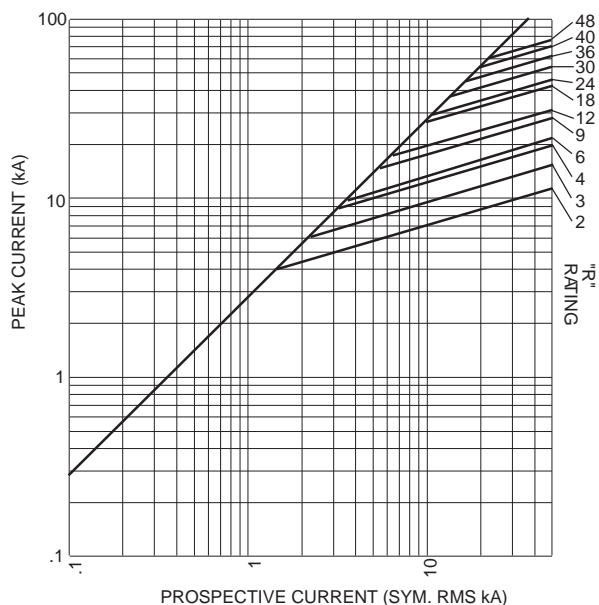

Application for HV Motor Circuit Fuses

The following table is a general guide only based on a number of assumptions regarding the motor duty application which are listed below. Contact Edison Customer Satisfaction for specific application information. The application tables are based on the following assumptions:

Motor Efficiency ----- 90% Run Up Time ----- 10 Secs.
 Motor Power Factor ----- 0.9 Starting Method -- Full Voltage
 Starting Current ----- 6 x FLA Min. Fuse Size ---- 1.3 x FLA
 Starts/Hour ----- Max of 2/Hour

Hp	2.4kV			4.16kV			4.8kV		
	FLA Amps	FUUSE "R"	Amps	FLA Amps	FUUSE "R"	Amps	FLA Amps	FUUSE "R"	Amps
75	17	2R	70	-	-	-	-	-	-
100	22	2R	70	-	-	-	-	-	-
125	28	3R	70	16	2R	70	-	-	-
150	33	3R	100	19	2R	70	17	2R	70
200	44	4R	130	26	3R	100	22	2R	70
250	55	6R	170	32	3R	100	28	3R	100
300	67	6R	170	38	4R	130	33	3R	100
350	78	9R	170	45	4R	130	39	4R	130
400	89	9R	200	45	4R	130	44	4R	130
500	111	12R	230	64	6R	170	55	6R	170
600	133	18R	390	77	9R	200	67	6R	170
700	155	18R	390	90	9R	200	78	9R	200
800	177	18R	390	102	9R	230	89	9R	200
900	200	18R	390	115	12R	230	100	9R	200
1000	222	24	450	128	18R	390	111	12R	230
1100	244	24R	450	141	18R	390	122	12R	230
1200	266	24R	450	154	18R	390	133	18R	390
1400	311	30R	450	179	18R	390	155	18R	390
1600	355	36R	500	205	18R	390	177	18R	390
1800	399	40R	600	230	24R	450	200	18R	390
1900	422	40R	600	243	24R	450	211	18R	390
2000	444	40R	600	256	24R	450	222	24R	450
2200	488	48R	650	282	30R	450	244	24R	450
2400	-	-	-	307	30R	450	266	24R	450
2600	-	-	-	333	36R	500	288	30R	450
2800	-	-	-	358	36R	500	311	30R	450
3000	-	-	-	384	36R	500	333	36R	500
3500	-	-	-	448	40R	600	388	36R	500
4000	-	-	-	-	-	-	444	40R	600
4500	-	-	-	-	-	-	500	48R	650

Contact Edison Customer Satisfaction for applications regarding other operating conditions.



E-Rated Power Fuses Having Full Range Clearing Capability for Medium Voltage Transformer Circuit Protection

Part Number	Amp Rating	Length (In)	Dia. (In)	# of Barrels	Clip Center (In)
MV055F1CAX5E	5E	15.75	2	1	12
MV055F1CAX7E	7E	15.75	2	1	12
MV055F1CAX10E	10E	15.75	2	1	12
MV055F1CAX15E	15E	15.75	2	1	12
MV055F1CAX20E	20E	15.75	2	1	12
MV055F1CAX25E	25E	15.75	2	1	12
MV055F1CAX30E	30E	15.75	2	1	12
MV055F1CAX40E	40E	15.75	2	1	12
MV055F1CAX50E	50E	15.75	2	1	12
MV055F1CAX65E	65E	15.75	2	1	12
MV055F1DAX10E	10E	15.75	3	1	12
MV055F1DAX15E	15E	15.75	3	1	12
MV055F1DAX20E	20E	15.75	3	1	12
MV055F1DAX25E	25E	15.75	3	1	12
MV055F1DAX30E	30E	15.75	3	1	12
MV055F1DAX40E	40E	15.75	3	1	12
MV055F1DAX50E	50E	15.75	3	1	12
MV055F1DAX65E	65E	15.75	3	1	12
MV055F1DAX80E	80E	15.75	3	1	12
MV055F1DAX100E	100E	15.75	3	1	12
MV055F1DAX125E	125E	15.75	3	1	12
MV055F1DAX150E	150E	15.75	3	1	12
MV055F1DAX175E	175E	15.75	3	1	12
MV055F1DAX200E	200E	15.75	3	1	12
MV055F2DAX250E	250E	15.75	3	2	12
MV055F2DAX300E	300E	15.75	3	2	12
MV055F2DAX350E	350E	15.75	3	2	12
MV055F2DAX400E	400E	15.75	3	2	12

MV055 Specifications

E-Rated Medium Voltage Fuses

Meets E-Rating requirements of ANSI C37.46

Meets Full Range requirements of ANSI C37.40.

Voltage Rating: 5,500Vac

Interrupting Rating: 50kA Maximum Symmetrical Amps

Current Limiting

Benefits:

- Standard clip center lengths and barrel diameters.
- 100% tested for reliability.
- Suitable for indoor or outdoor usage.
- Full Range capability.

Applications:

- For transformer and feeder protection.

Recommended Fuseclips:

Refer to page 109 in this catalog.

CROSS REFERENCE

NEW EDISON	OLD EDISON	GOULD (old/new)	WESTINGHOUSE	GE (old/new)
MV055F1CAX	—	A550X – 1B/A055F1CORO	—	—
MV055F1DAX	5.5FFNHA or K	A550X – 1F/A055F1DORO	151D978G01 thru G08	9F60FJDxxx/9F62DCBxxx
MV055F1DAX	5.5BFNHA	—	5HLExxxE – 1	—
MV055F2DAX	5.5BFNHK	A550X – 1/A055F2DORO	151D978G11 thru G13	9F60GHC (250-400)

E-Rated Medium Voltage Fuses for Transformer and Feeder Protection

Time-Current Characteristics—Min. Melt

Time-Current Characteristics—Total Clear

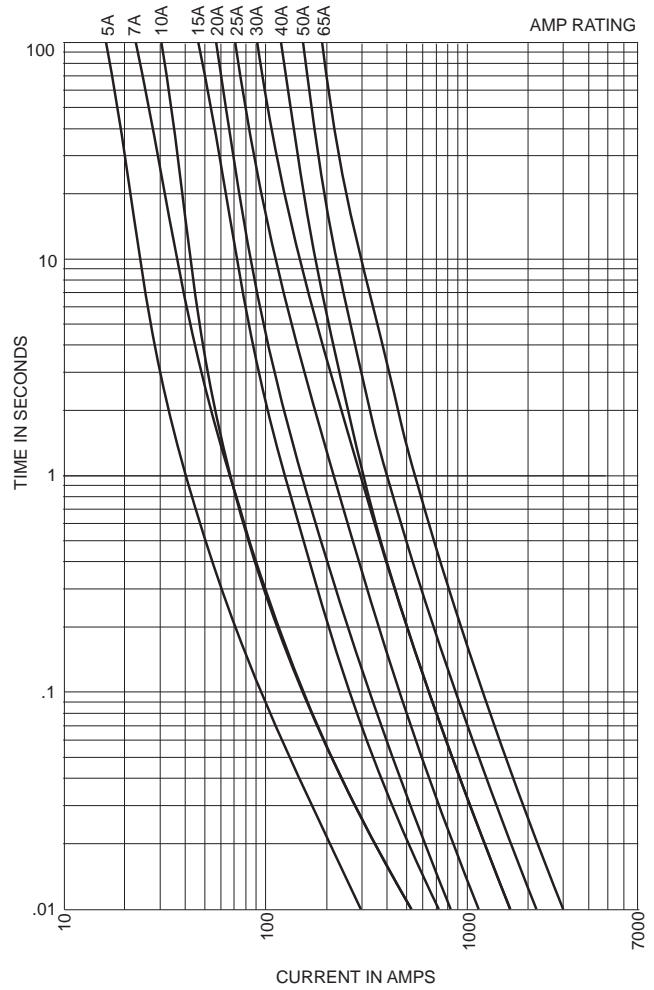
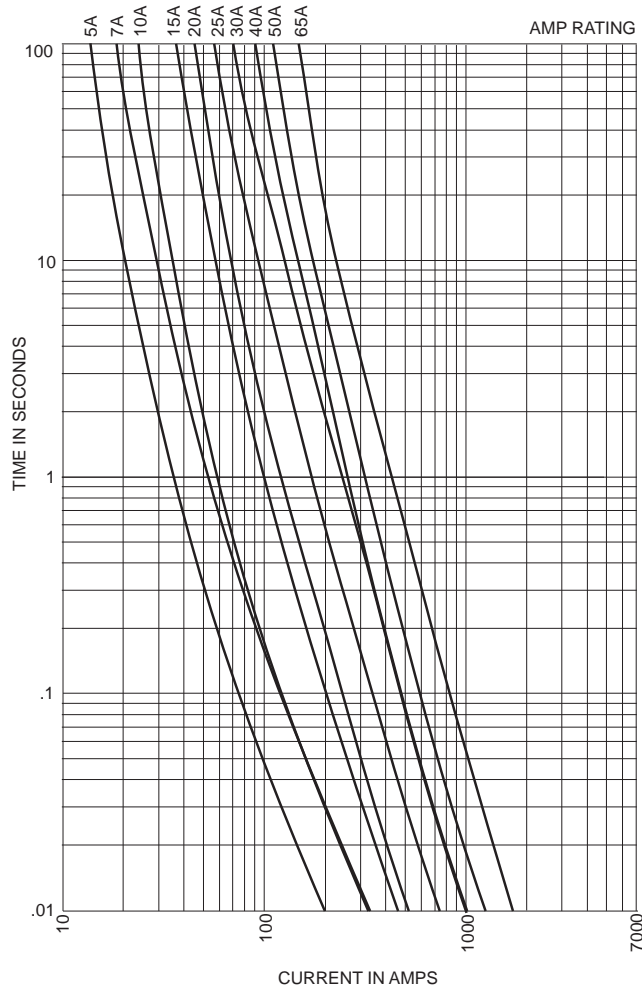

Dimensions - in

MV055F1CAX

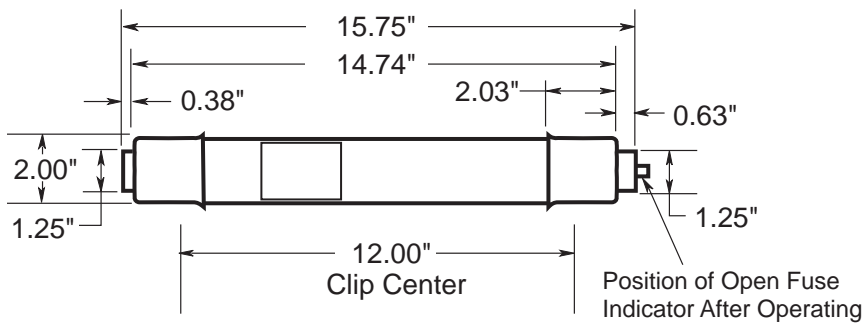

E-Rated Medium Voltage Fuses for Transformer and Feeder Protection

Time-Current Characteristics—Min. Melt

Time-Current Characteristics—Total Clear

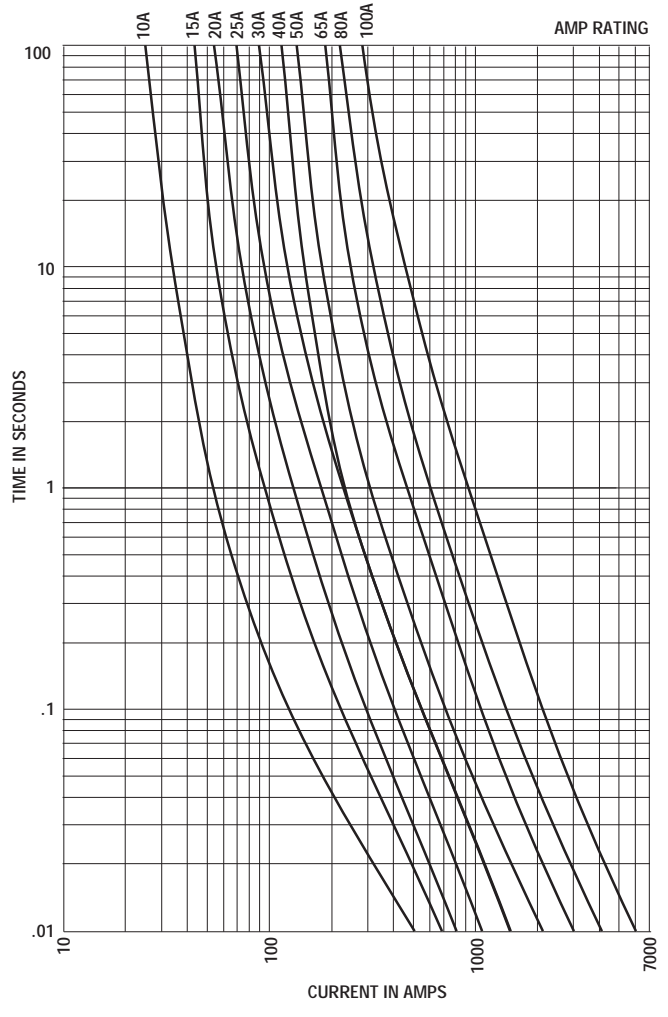
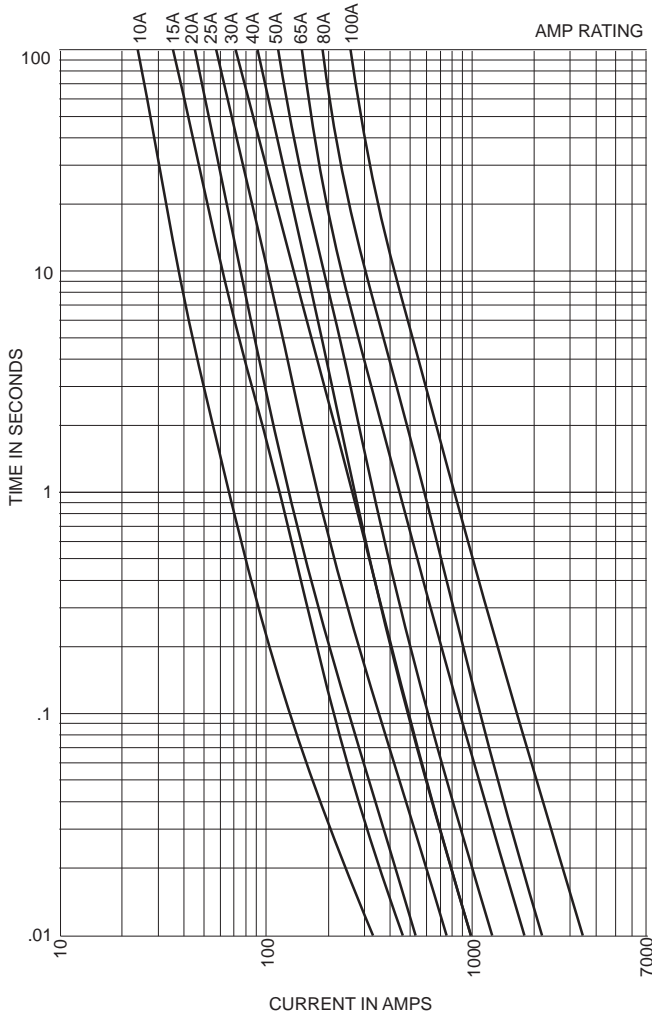

Dimensions - in

MV055F1DAX

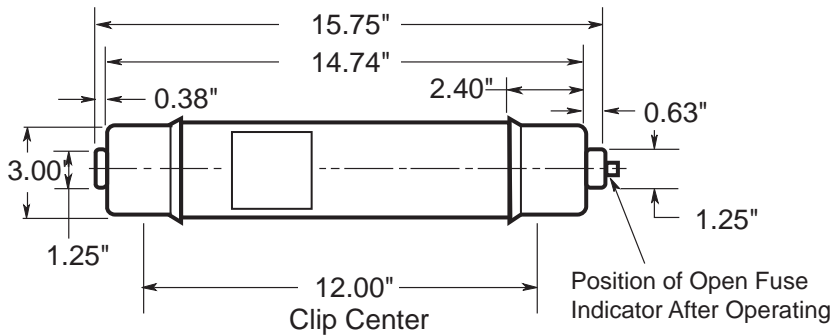

UL/CSA Fuses
Current Limiting

UL/CSA Fuses
General Purpose

Special
Purpose Fuses

Canadian
Fuses & Holders

Medium
Voltage Fuses

Fuse Blocks,
Holders & Misc.

Application
Section

E-Rated Medium Voltage Fuses for Transformer and Feeder Protection

Maximum Peak Let-Through Current Curves

Max. Peak Arc Voltage for E-Rated Full Range Power Fuse

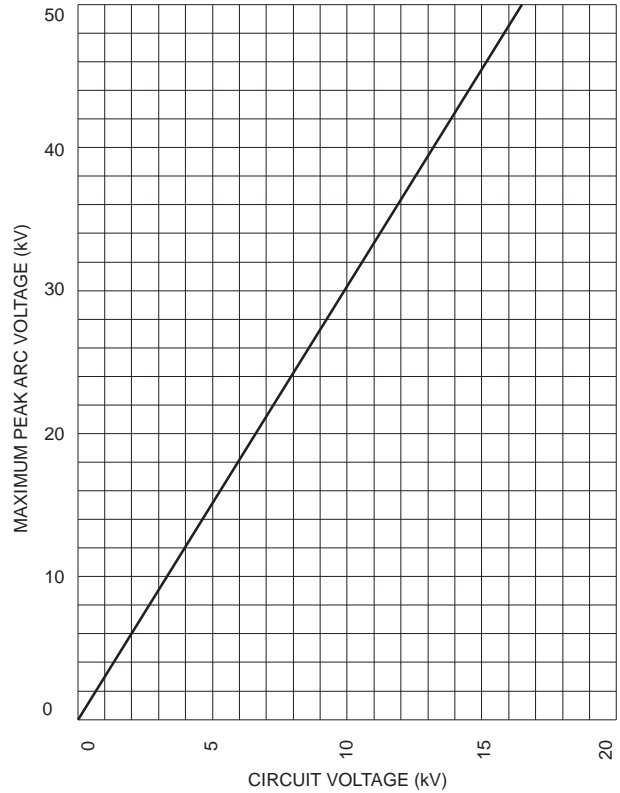
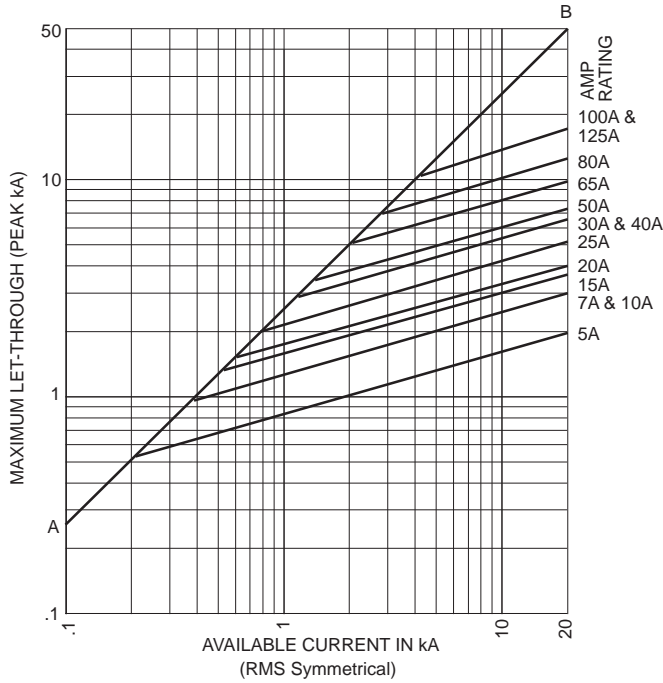

Recommended Fuse Clips for Medium Voltage Fuses

Part No.	Fuse Diameter	Clip Dimensions - in						
		A	B	C	D	E	F	G
A3354710	2 inches	3.39	1.97	2.00	1.18	4.41	1.50	0.39
A3354730	3 inches	3.94	2.44	3.00	1.18	5.51	1.50	0.39

Fuseclips are for single barrel applications only.

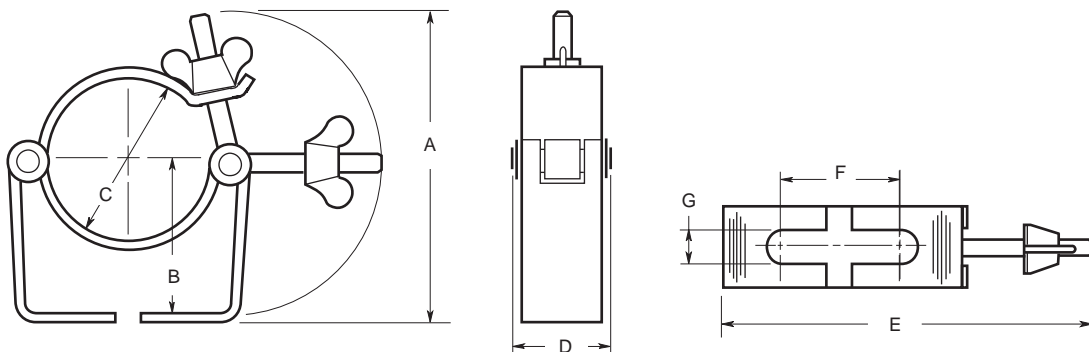



E-Rated Power Fuses Having Full Range or Back-up Clearing Capability for Medium Voltage Transformer Circuit Protection

Part Number	Amp Rating	Length (In)	Dia. (In)	# of Barrels	Clip Center (In)
8.25FFNHA20E	20E	15.88	3	1	12
8.25FFNHA25E	25E	15.88	3	1	12
8.25FFNHA30E	30E	15.88	3	1	12
8.25FFNHA40E	40E	15.88	3	1	12
8.25FFNHA50E	50E	15.88	3	1	12
8.25FFNHA65E	65E	15.88	3	1	12
8.25FFNHA75E	75E	15.88	3	1	12
8.25FFNHK100E	100E	15.88	3	2	12
8.25FFNHK150E	150E	15.88	3	2	12
8.25BFNHA80*	80A	15.88	3	1	12
8.25BFNHA100*	100A	15.88	3	1	12
8.25BFNHK150*	150A	15.88	3	2	12
8.25BKNHK200*	200A	15.88	3	2	12

*Back-up protection only.

8.25FFNH Specifications

E-Rated Medium Voltage Fuses

Meets E-Rating requirements of ANSI C37.46

Meets Full Range requirements of ANSI C37.40

8.25BFNH Specifications

Back-up Medium Voltage Fuses

Meets Back-up requirements of ANSI C37.40

Voltage Rating: 8250Vac

Interrupting Rating: 80kA Max. Sym. Amps

Current Limiting

Low power dissipation

Low arc voltage during operation

Benefits:

- Standard clip center lengths and barrel diameters.
- Standard blown fuse striker pin may be used for indication or tripping purposes.
- 100% tested for reliability.
- Suitable for indoor or outdoor usage.

Applications:

- For transformer and feeder protection.

Recommended Fuse Clips:

Refer to page 109 in this catalog.

CROSS REFERENCE			
EDISON	GOULD	WESTINGHOUSE	GE (old/new)
8.25FFNHA	A825X (amp)E-1	677C573Gxx	6193481Gxx/9F60FJE (amp)
8.25FFNHK	A825X150-200E-1	—	9F60HJE150
8.25BKNHK200	A825X200E-1	—	9F60HJE200

E-Rated Medium Voltage Fuses for 8.25 FFNHA and 8.25 FFNHK Fuses

Time-Current Characteristics – Min. Melt

Time-Current Characteristics – Total Melting

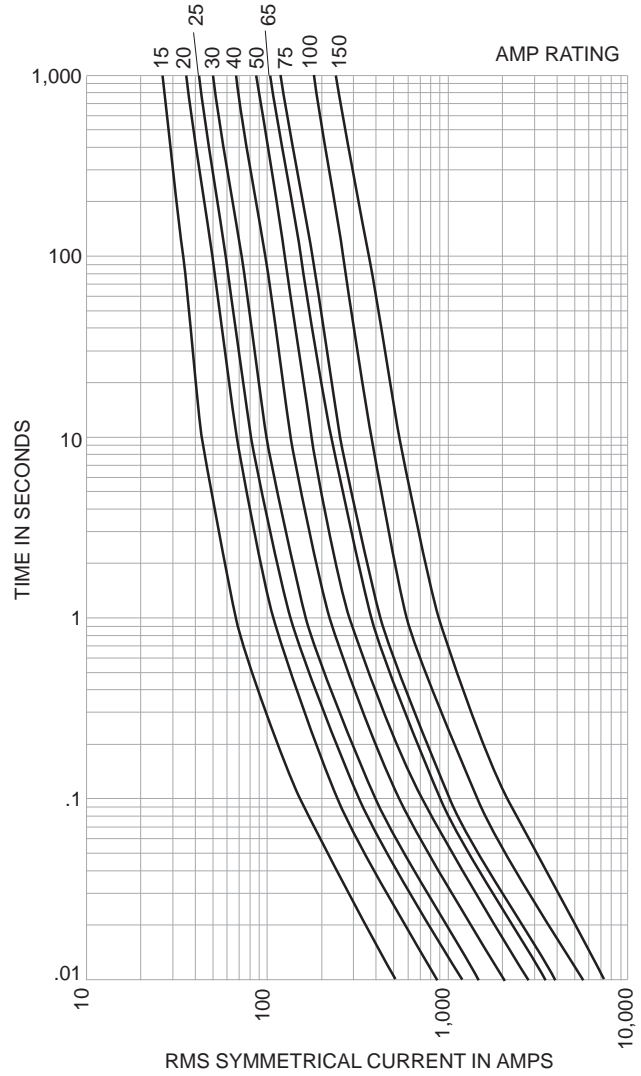
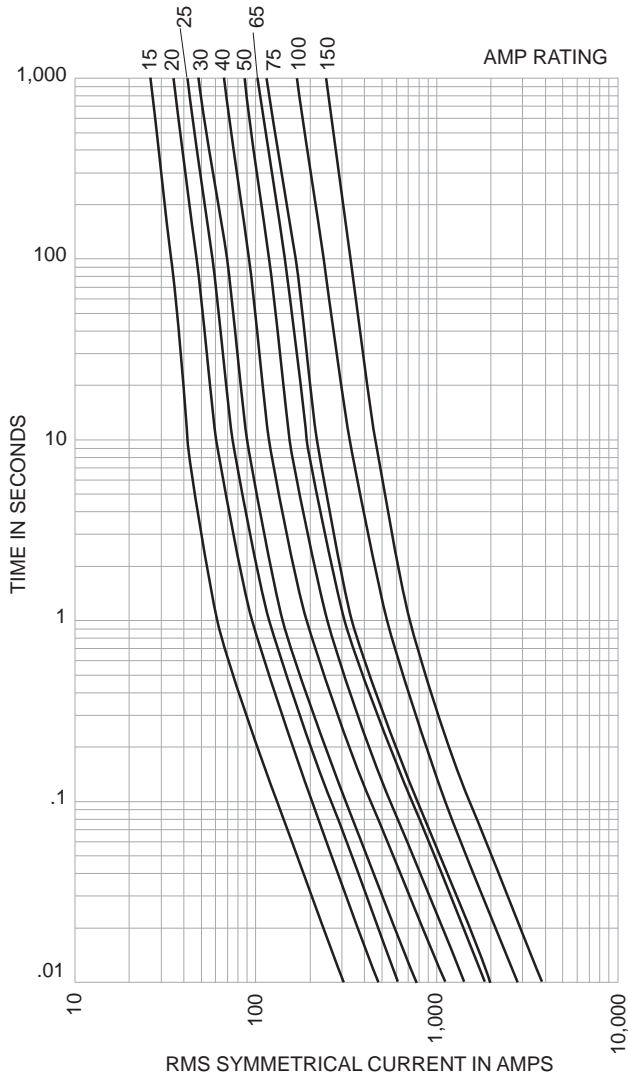

1A0065
3" Diameter Clip

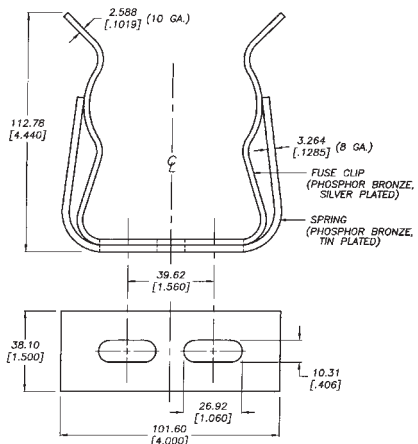

2 CLIP ASSEMBLIES PER PACKAGE.
DIMENSIONS SHOWN ARE FOR REFERENCE ONLY.

9078A67G04
3" Diameter Clip

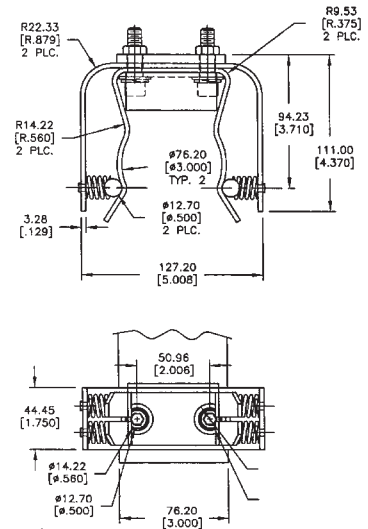

2 Cup assemblies per package.
Dimensions shown are for reference only.

UL/CSA Fuses
Current Limiting

UL/CSA Fuses
General Purpose

Special
Purpose Fuses

Canadian
Fuses & Holders

Medium
Voltage Fuses

Fuse Blocks,
Holders & Misc.

Application
Section

Back-up Medium Voltage Fuses for 8.25 BFNHA, 8.25 BFHNK, and 8.25 BKNHK Fuses
Time-Current Characteristics—Min. Melt

Time-Current Characteristics—Max. Clear

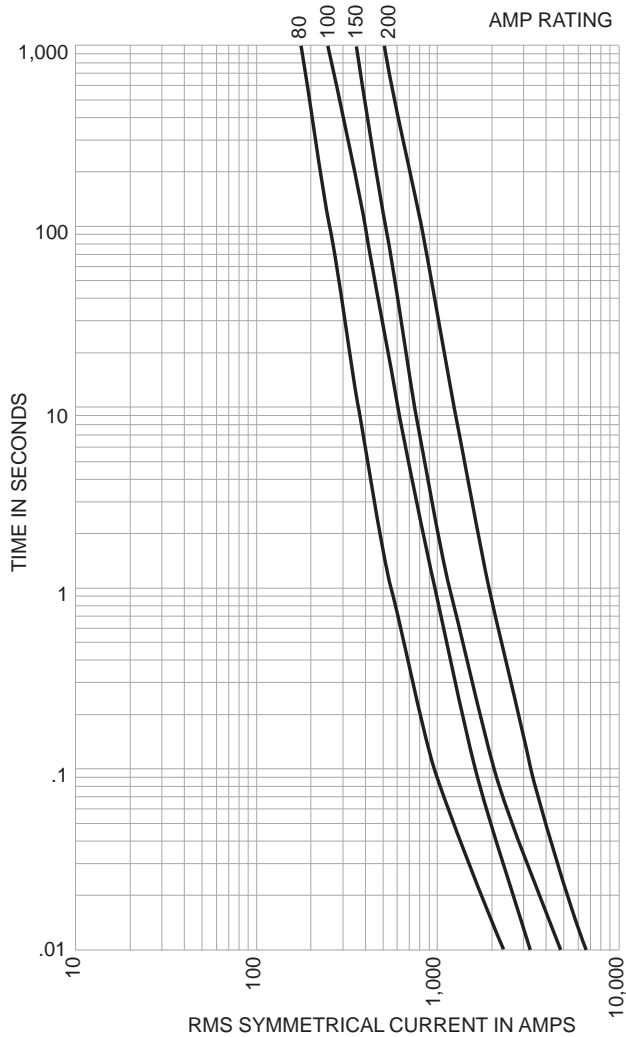
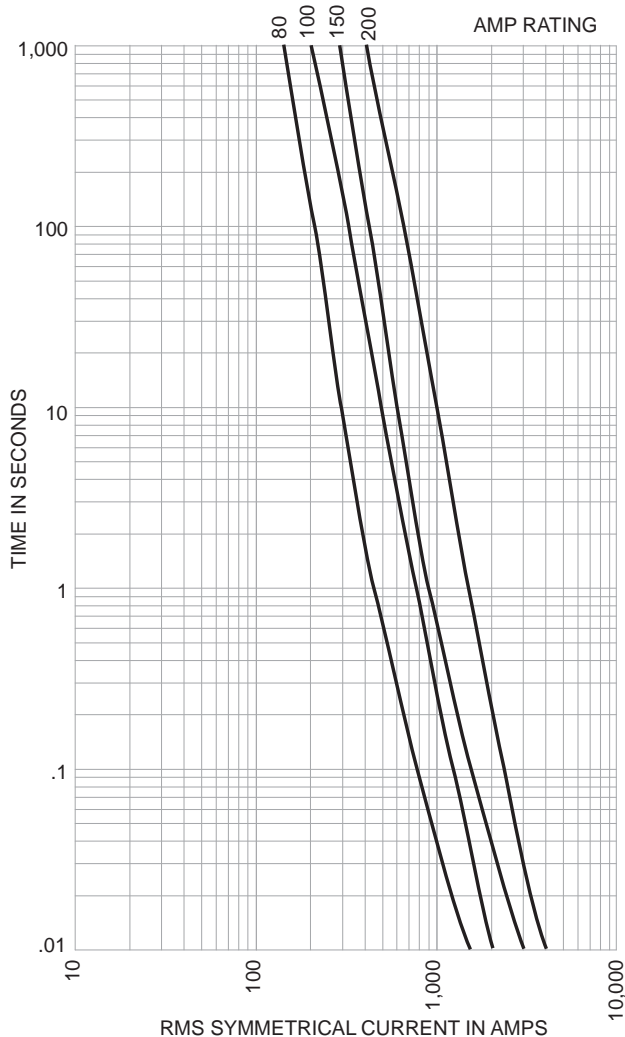



E-Rated Power Fuses Having Full Range Clearing Capability for Medium Voltage Transformer Circuit Protection

Part Number	Amp Rating	Length (In)	Dia. (In)	# of Barrels	Clip Center (In)
MV155F1CBX5E	5E	18.75	2	1	15
MV155F1CBX7E	7E	18.75	2	1	15
MV155F1CBX10E	10E	18.75	2	1	15
MV155F1CBX15E	15E	18.75	2	1	15
MV155F1CBX20E	20E	18.75	2	1	15
MV155F1CBX25E	25E	18.75	2	1	15
MV155F1CBX30E	30E	18.75	2	1	15
MV155F1DBX10E	10E	18.75	3	1	15
MV155F1DBX15E	15E	18.75	3	1	15
MV155F1DBX20E	20E	18.75	3	1	15
MV155F1DBX25E	25E	18.75	3	1	15
MV155F1DBX30E	30E	18.75	3	1	15
MV155F1DBX40E	40E	18.75	3	1	15
MV155F1DBX50E	50E	18.75	3	1	15
MV155F1DBX65E	65E	18.75	3	1	15
MV155F1DBX80E	80E	18.75	3	1	15
MV155F1DBX100E	100E	18.75	3	1	15
MV155F2DBX125E	125E	18.75	3	2	15
MV155F2DBX150E	150E	18.75	3	2	15
MV155F2DBX175E	175E	18.75	3	2	15
MV155F2DBX200E	200E	18.75	3	2	15
MV155F1DCX65E	65E	21.75	3	1	18
MV155F1DCX80E	80E	21.75	3	1	18
MV155F1DCX100E	100E	21.75	3	1	18
MV155F2DCX125E	125E	21.75	3	2	18
MV155F2DCX150E	150E	21.75	3	2	18
MV155F2DCX175E	175E	21.75	3	2	18
MV155F2DCX200E	200E	21.75	3	2	18

MV155 Specifications

E-Rated Medium Voltage Fuses

Meets E-Rating requirements of ANSI C37.46

Meets Full Range requirements of ANSI C37.40.

Voltage Rating: 15,500Vac

Interrupting Rating: 50kA Maximum Symmetrical Amps

Current Limiting

Benefits:

- Standard clip center lengths and barrel diameters.
- 100% tested for reliability.
- Suitable for indoor or outdoor usage.
- Full Range capability.

Applications:

- For transformer and feeder protection.

Recommended Fuseclips:

Refer to page 114 in this catalog.

CROSS REFERENCE

NEW EDISON	OLD EDISON	GOULD (old/new)	WESTINGHOUSE	GE (old/new)
MV155F1CBX	—	A1550X – 1B/A155F1CORO	—	—
MV155F1DBX	15.5FFVHA	A1550X – 1F/A155F1DORO (10-50E)	15HLE-xxxE	9F60FMH/9F62DDD
MV155F2DBX	15.5FFVHK	—	—	—
MV155F1DCX	—	A1550X – 1D/A155F1DORO (65-100E)	—	—
MV155F2DCX	—	A1550X – 1D/A155F2DORO (125-200E)	—	—

E-Rated Medium Voltage Fuses for Transformer and Feeder Protection

Time-Current Characteristics – Min. Melt

Time-Current Characteristics –Total Clear

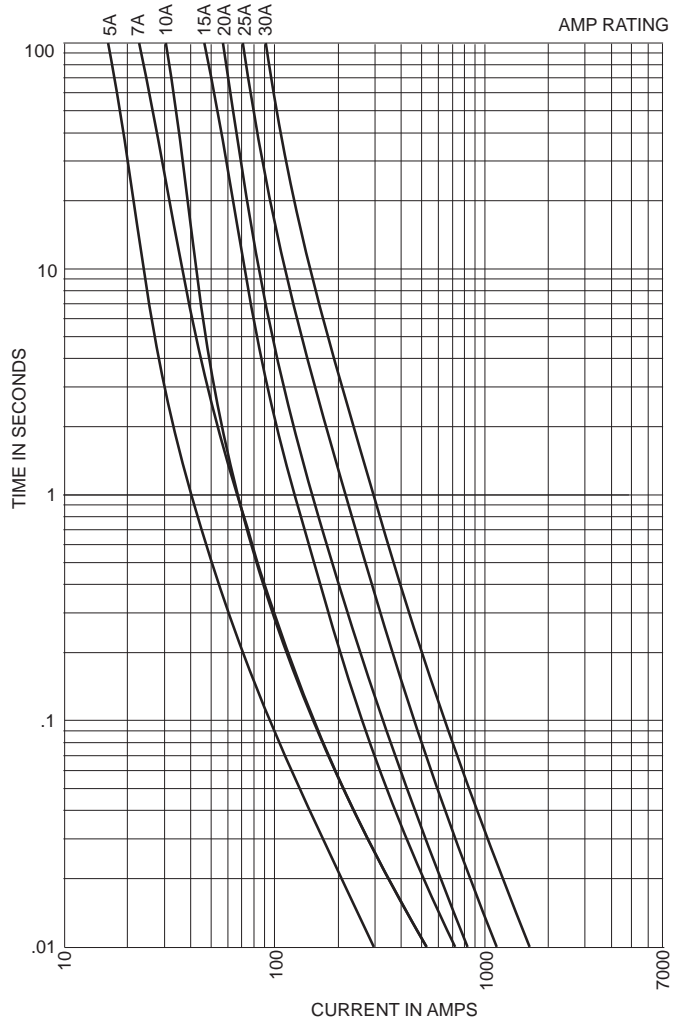
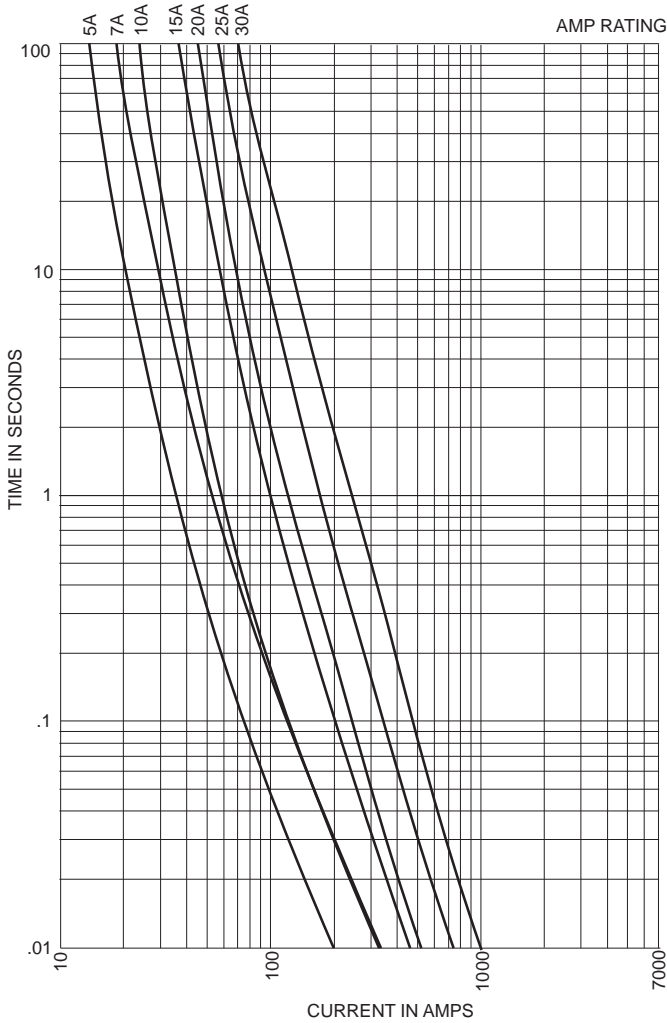

Dimensions - in

MV155F1CBX

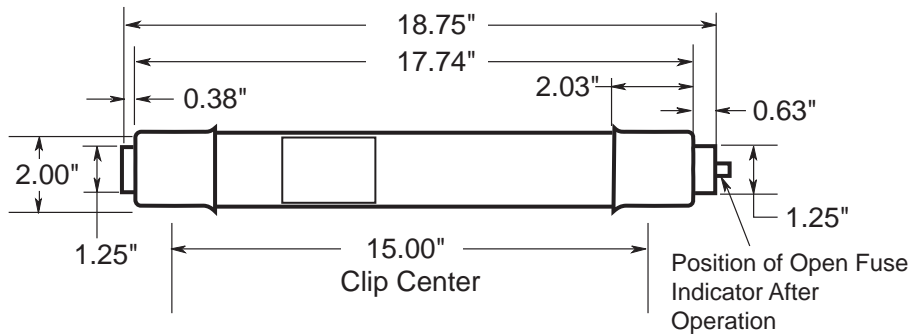

UL/CSA Fuses
Current Limiting

UL/CSA Fuses
General Purpose

Special
Purpose Fuses

Canadian
Fuses & Holders

Medium
Voltage Fuses

Fuse Blocks,
Holders & Misc.

Application
Section

E-Rated Medium Voltage Fuses for Transformer and Feeder Protection

Time-Current Characteristics – Min. Melt

Time-Current Characteristics – Total Clear

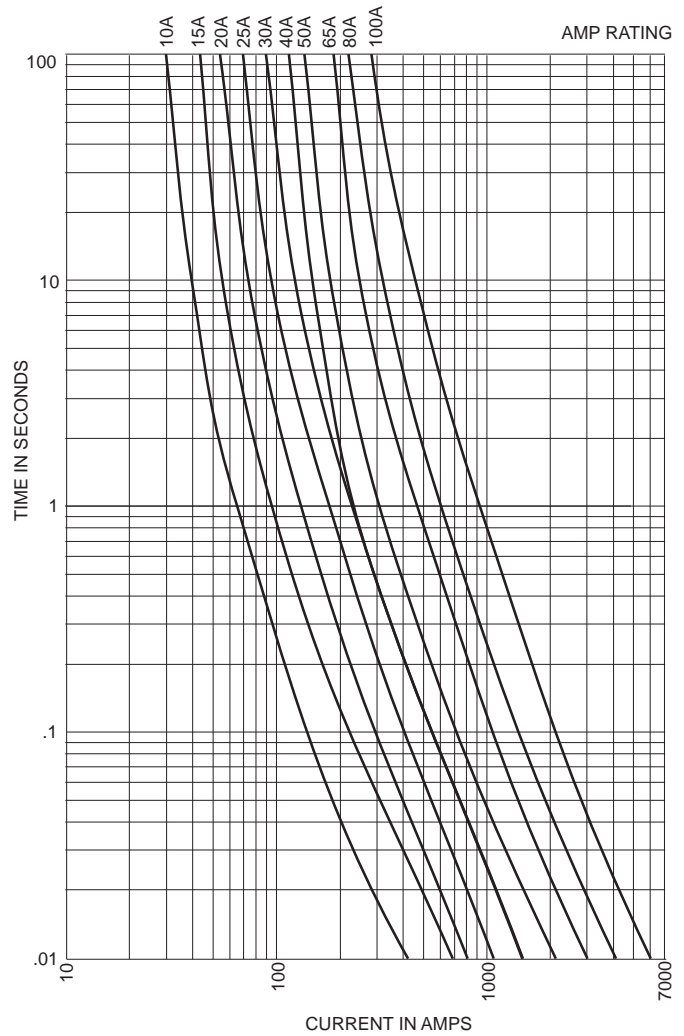
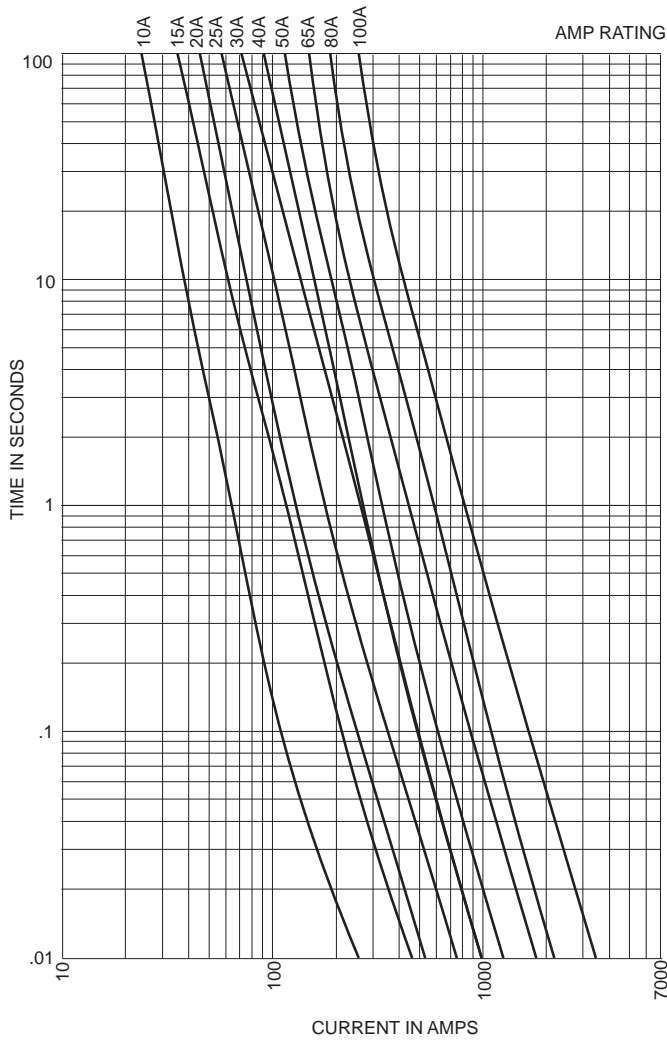

Dimensions - in

MV155F1DBX

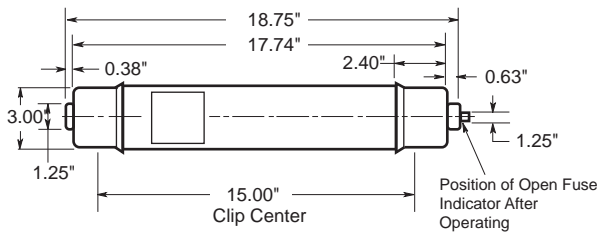

MV155F1DCX

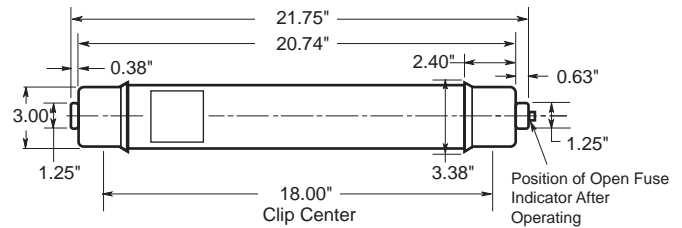

E-Rated Medium Voltage Fuses for Transformer and Feeder Protection

Max. Peak Let-through Current Curves

Maximum Peak Arc Voltage for E-Rated Full Range Power Fuse

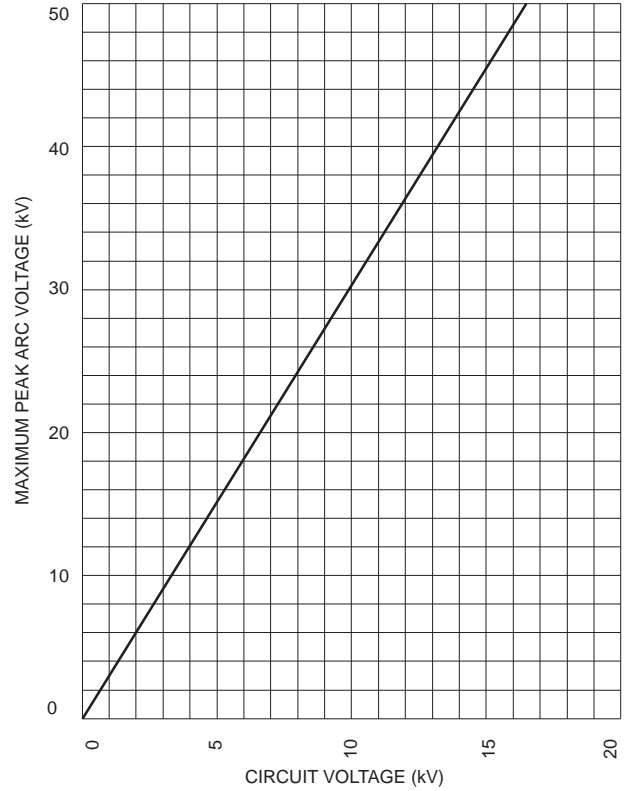
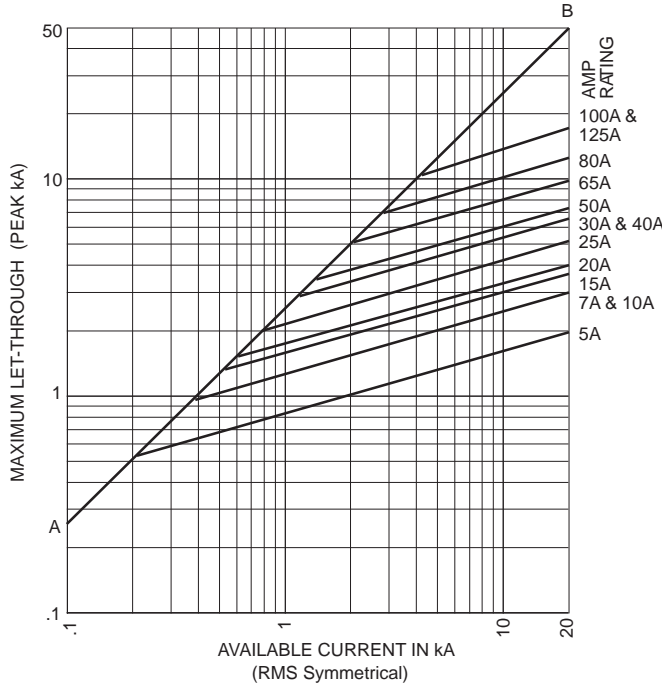

Recommended Fuse Clips for Medium Voltage Fuses

Part No.	Fuse Diameter	Clip Dimensions - in						
		A	B	C	D	E	F	G
A3354710	2 inches	3.39	1.97	2.00	1.18	4.41	1.50	0.39
A3354730	3 inches	3.94	2.44	3.00	1.18	5.51	1.50	0.39

Fuseclips are for single barrel applications only.

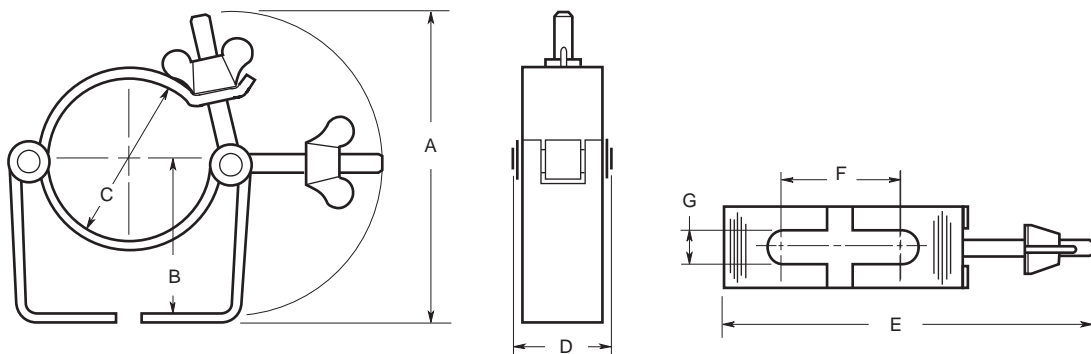

UL/CSA Fuses
Current Limiting

UL/CSA Fuses
General Purpose

Special
Purpose Fuses

Canadian
Fuses & Holders

Medium
Voltage Fuses

Fuse Blocks,
Holders & Misc.

Application
Section



These are a range of fuses with low current rating, for use with voltage transformers or operating transformers to provide isolation of the associated system in the event of faults in the transformer circuit.

Advantages of Edison Potential Transformer Fuses

Most fuses have two elements in parallel, ensuring satisfactory operation at much smaller values of overcurrent than is possible with single element fuse.

The elements are wound on a ceramic former, thus ensuring correct spacing of the elements from the body wall and from each other and hence giving assurance of correct operation in service.

Switching (arc) voltages comply with the IEC282-1.

Application Notes

1. In order to minimize the risk of deterioration of the fine fuse elements caused by corona, it is desirable to mount the fuses so that grounded metal is not in the immediate vicinity of the part of the barrel between the ferrules.
2. It is recommended that all three fuses are replaced when the fuse in one or two phases has operated unless it is definitely known that no overcurrent has passed through the unopened fuses.

AB & AM Series Fuses for Potential Transformers

kV	Catalog Number	Amp Ratings	Type	Dimensions - inches (Figure 1)		IR
				Length	Diameter	
3.6	3.6ABWNA(amp)	3.15, 6.3	AB	5.6	1	50kA
3.6	3.6ABCNA(amp)	3.15, 6.3, 10	AB	7.69	1	
5.5	5.5ABWNA(amp)	0.5E, 1.0E, 2.0E, 3.0E, 5.0E	AB	5.6	1	
5.5	5.5AMWNA(amp)	0.5E, 1.0E, 2.0E, 3.0E, 4.0E, 5.0E	AM	5.6	0.81	
7.2	7.2ABWNA(amp)	3.15, 6.3	AB	5.6	1	
7.2	7.2ABCNA(amp)	3.15, 6.3	AB	7.69	1	
12.0	12ABCNA(amp)	3.15	AB	7.69	1	
15.5	15.5ABFNA(amp)	3.15	AB	10.00	1	
17.5	17.5ABGNA(amp)	3.15	AB	14.13	1	
24.0	24ABGNA(amp)	3.15	AB	14.13	1	
36.0*	36ABGNA(amp)	3.15	AB	14.13	1	

*For clean indoor applications only.

CAV Series Fuses for Potential Transformers

kV	Catalog Number	Amp Ratings	Type	Dimensions - inches (Figure 2)		IR
				Length	Diameter	
3.6	3.6CAV(amp)	2	8CAV	8.66	1.63	40kA
5.5	5.5CAV(amp)	15E	7CAV	7.375		
5.5	5.5CAVH(amp)	0.5E, 1E, 2E	7CAVH	7.375		
7.2	7.2CAV(amp)	2, 4, 6, 10	8CAV	8.66		
12	12CAV(amp)	2	8CAV	8.66		
15.5	15.5CAV(amp)	0.5E, 1E, 2E, 3E, 7E	12CAV	12.87		
15.5	15.5CAVH(amp)	0.5E, 1E, 2E	12CAVH	12.87		
17.5	17.5CAV(amp)	2, 4, 6, 10	8CAV	8.66		
24	24CAV(amp)	2, 3, 4	13CAV	13.39		
36	36CAV(amp)	2, 4	17CAV	17.32		
38	38CAV(amp)	4E	17CAV	17.32		
38	38CAVH(amp)	0.5E, 1E, 2E	17CAV	17.32		

Dimensions - in (mm)

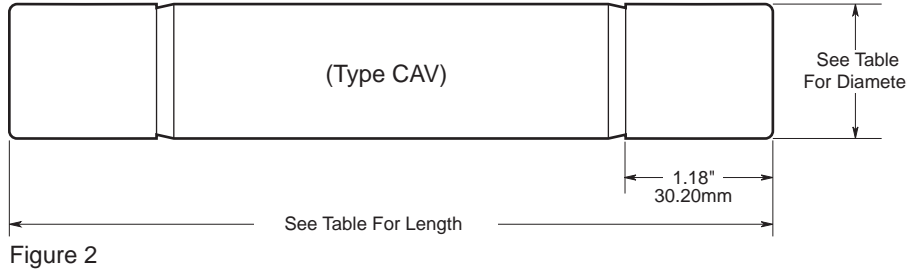
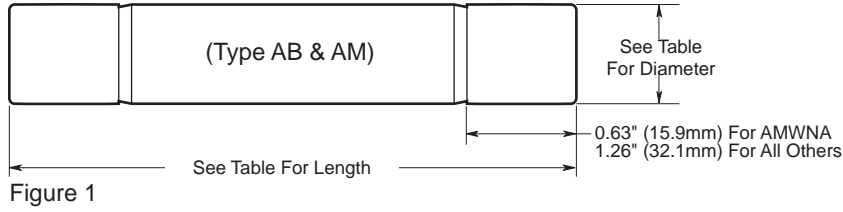

Fuseclips

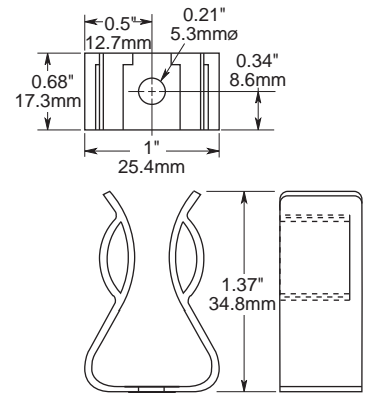

Part No. A3354705
For 1" diameter potential transformer fuses.

Time-Current Curves

5.5kV AMWNA

5.5kV ABWNA

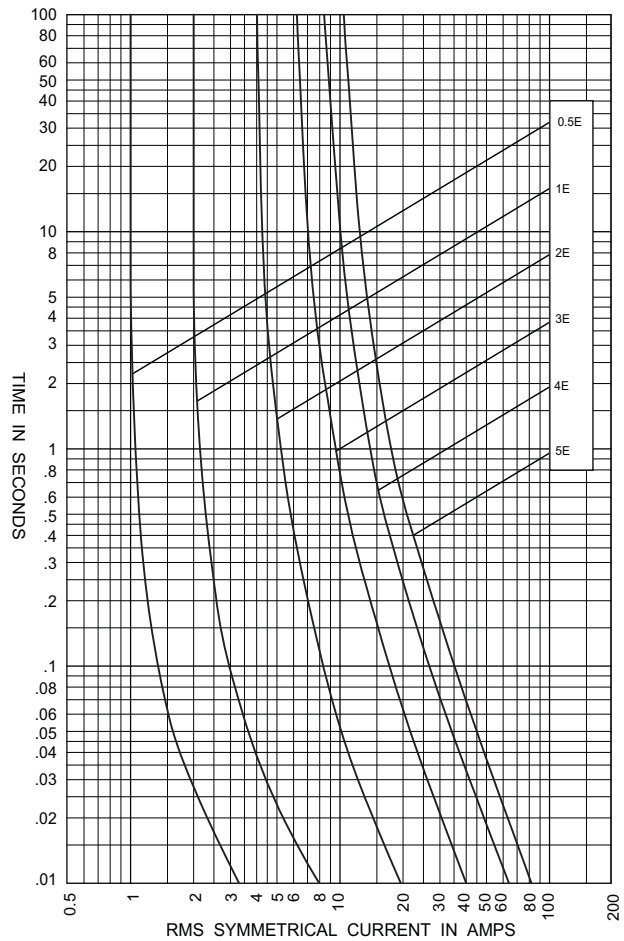
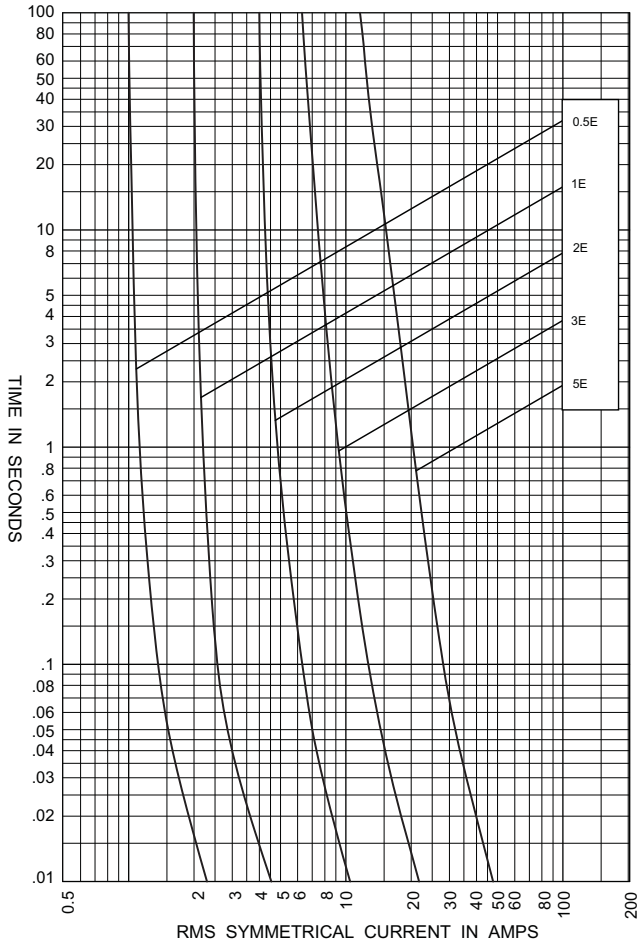



**DIN Dimension Fuses To Specification
DIN 43.625**

This product group covers current limiting fuses with dimensions to DIN 43.625 and performance in compliance with IEC 282-1.

Advantages of Edison High Voltage Current - Limiting Fuses

The low power dissipation of Edison fuses ensures low temperature rise of switchgear in which they are incorporated.

The elements use the 'M' (metallurgical) effect, similar to that used in low voltage fuses. This ensures that, with melting on long time overloads, excessive temperatures are not reached and damage to switchgear components, such as epoxy encapsulating enclosures, is thus prevented. Fuses that do not employ this feature are not only hotter running by comparison but also usually need to employ a higher current rating of fuse for the same service; thus an Edison 40A fuse is equivalent in terms of thermal

performance to many other types of 63A rating.

Edison fuses exhibit considerable limitation of current and I^2t under short-circuit conditions. The stress on circuit components is thereby minimized and the reduction of energy release at the fault reduces fire risks.

Switching (arc) voltages are appreciably less than permitted values and fall with lower values of recovery voltage. The use of, for example, 12kV fuse on 6/7.2kV systems is therefore permissible.

Striker Characteristics

The spring operated striker pin has a travel and energy output in compliance with the requirements of DIN 43625 and IEC 282-1.

Recommended Fuse Clips:

Refer to page 121 in this catalog.

Dimensions - Inches (mm)

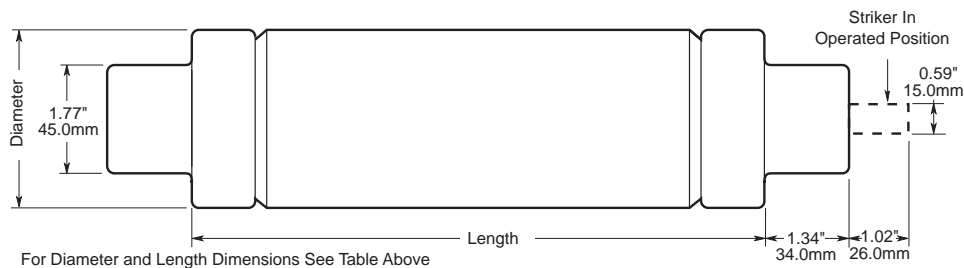

Ratings and Dimensions

kV	Catalog Numbers	Amp Ratings	Dimensions - in (mm) Diameter x Length	IR RMS Sym
3.6	3.6ADOSJ(amp)	6.3, 10, 16, 20, 25, 31.5, 40	2.00 x 7.56 (51 x 192)	50kA
	3.6WDOSJ(amp)	50, 63, 80, 100, 125	2.00 x 7.56 (51 x 192)	
	3.6WFOSJ(amp)	160, 200	3.00 x 7.56 (76 x 192)	
	3.6ADLSJ(amp)	25, 40	2.00 x 11.50 (51 x 292)	
	3.6WDL SJ(amp)	50, 63, 80, 100, 125	2.00 x 11.50 (51 x 292)	
	3.6WFLSJ(amp)	160, 200	3.00 x 11.50 (76 X 292)	
	3.6WKLSJ(amp)	250, 315, 400	3.00 x 11.50 (76 X 292)	
7.2	7.2DLSJ(amp)	6.3, 10, 16, 20, 25, 31.5, 40, 50, 63	2.00 x 11.50 (51 x 292)	40kA
	7.2TFLSJ(amp)	80, 100, 125, 160	3.00 x 11.50 (76 x 292)	
	7.2WKMSJ(amp)	200, 225, 250, 315, 355	3.00 x 17.41 (76 x 442)	
12	12TDLEJ(amp)	6.3, 10, 16, 20, 25, 31.5, 40, 50, 63	2.00 x 11.50 (51 x 292)	63kA
	12THLEJ(amp)	80, 100	2.52 x 11.50 (64 x 292)	
	12TKLEJ(amp)	125	3.00 x 11.50 (76 x 292)	
	12TXLEJ(amp)	160, 200	3.50 x 11.50 (88 x 292)	
17.5	17.5DLSJ(amp)	6.3, 10, 16, 20, 25, 31.5, 40	2.00 x 11.50 (51 x 292)	50kA
	17.5TFLSJ(amp)	50	2.00 x 11.50 (76 x 292)	35.5kA
	17.5TDMEJ(amp)	6.3, 10, 16, 20, 25, 31.5, 40, 50, 63	2.00 x 17.41 (51 x 442)	50kA
	17.5THMEJ(amp)	80, 100	2.52 x 17.41 (64 x 442)	
	17.5TKMEJ(amp)	125	3.00 x 17.41 (76 x 442)	
24	24TDMEJ(amp)	6.3, 10, 16, 20, 25, 31.5, 40, 50	2.00 x 17.41 (51 x 442)	50kA
	24THMEJ(amp)	63	2.52 x 17.41 (64 x 442)	
	24TFMEJ(amp)	80, 100	3.00 x 17.41 (76 x 442)	
	24TXMEJ(amp)	125, 160	3.46 x 17.41 (88 x 442)	
36	36TDOSJ(amp)	3.15, 6.3, 10, 16, 20, 25	2.00 x 21.16 (51 x 537)	31.5kA
	36TFQSJ(amp)	31.5, 40, 50	3.00 x 21.16 (51 x 537)	35.5kA
	36TXQEJ(amp)	63	3.46 x 21.16 (88 x 537)	20kA

Time-Current Characteristics–Average

For 3.6kV Fuses:

- 3.6ADOS 3.6WDLS
- 3.6WDOS 3.6WFLS
- 3.6ADLS 3.6WKLS

For 7.2kV Fuses:

- 7.2DLSJ
- 7.2TFLSJ
- 7.2WKMSJ

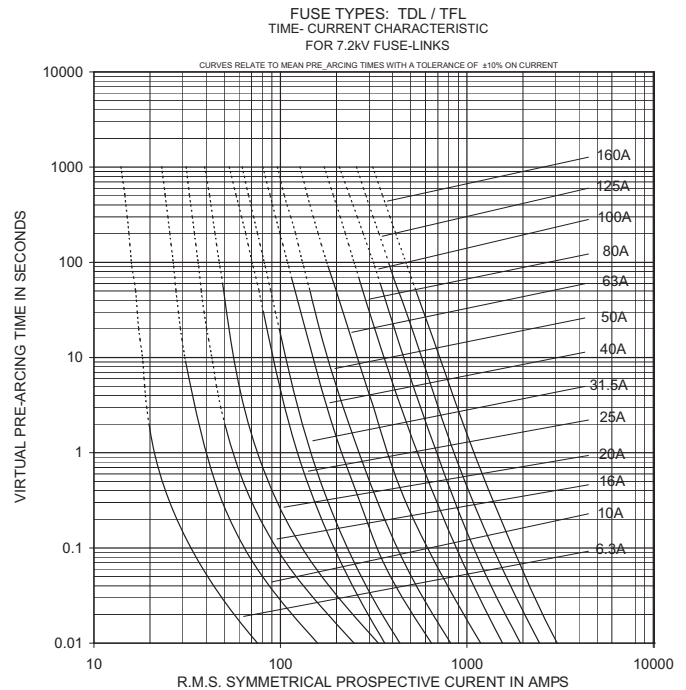
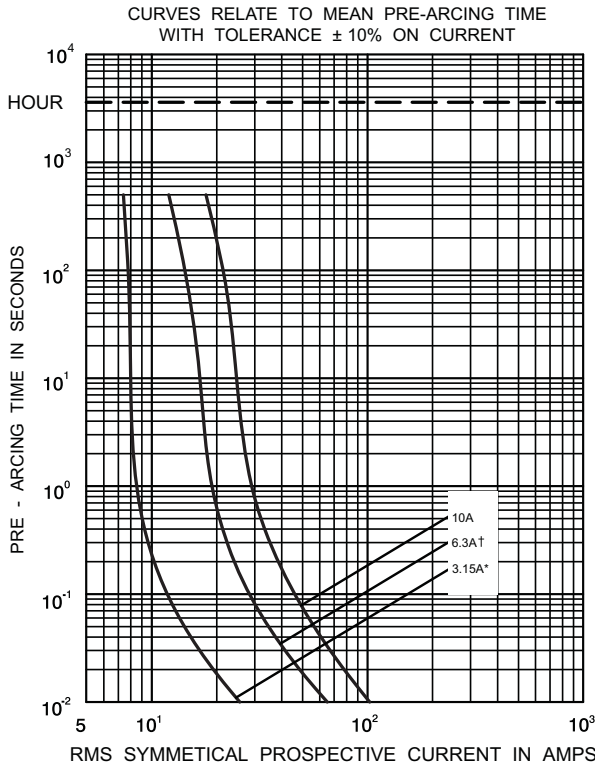

* Curve valid for all 3.15A ratings shown in the selection table.
 † Curve valid for all 6.3A ratings shown in the selection table.

Time-Current Characteristics–Average

- For 12kV Fuses: • 12TDLEJ • 12TXLEJ
 • 12THLEJ
 • 12TKLEJ

FUSE TYPES: TDL/THL/TKL
 TIME- CURRENT CHARACTERISTIC
 FOR 12KV FUSE-LINKS

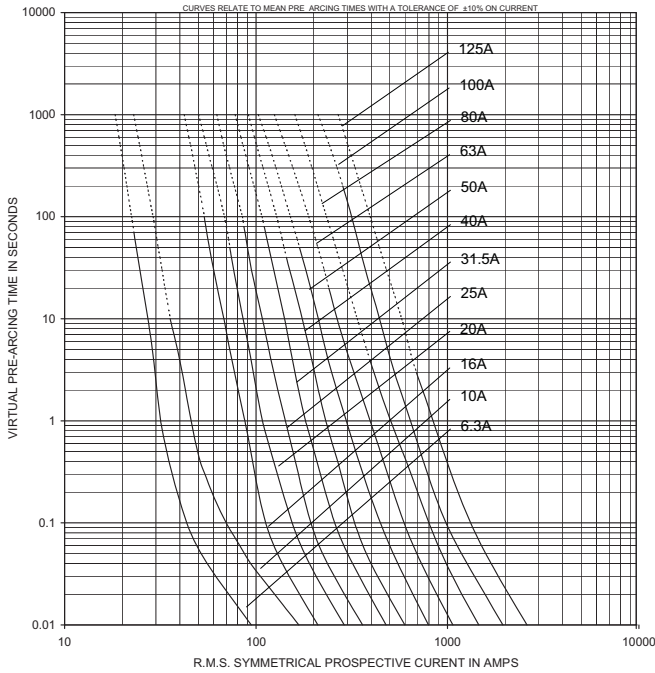

FUSE TYPES: THM / TKM / TFM
 TIME- CURRENT CHARACTERISTIC
 FOR 12KV FUSE-LINKS

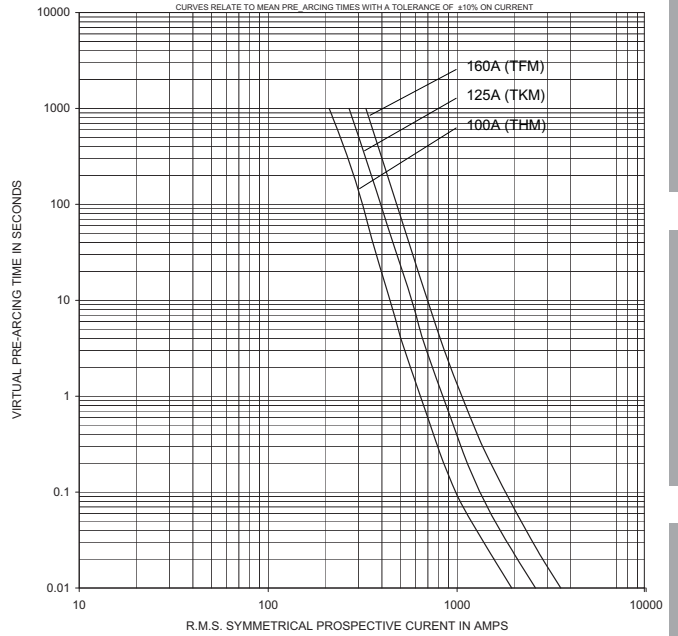

FUSE TYPES: TXL
 TIME- CURRENT CHARACTERISTIC
 FOR 12KV FUSE-LINKS

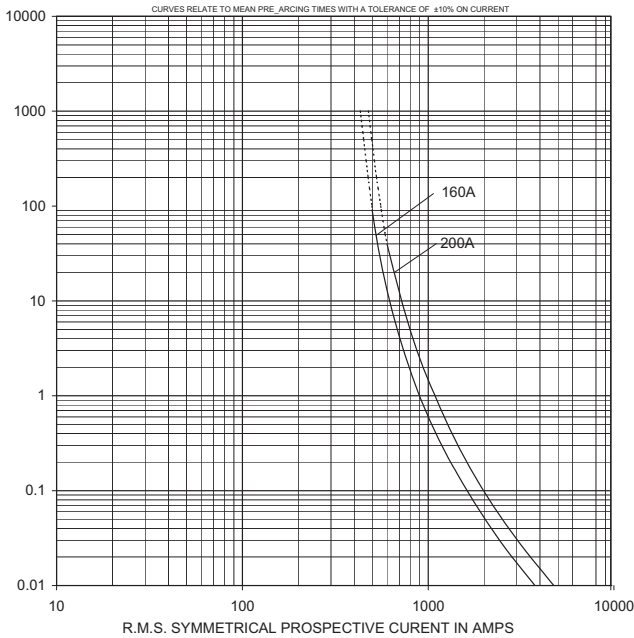

UL/CSA Fuses
 Current Limiting

UL/CSA Fuses
 General Purpose

Special
 Purpose Fuses

Canadian
 Fuses & Holders

Medium
 Voltage Fuses

Fuse Blocks,
 Holders & Misc.

Application
 Section

UL/CSA Fuses
Current Limiting

UL/CSA Fuses
General Purpose

Special
Purpose Fuses

Canadian
Fuses & Holders

Medium
Voltage Fuses

Fuse Blocks,
Holders & Misc.

Application
Section

Time-Current Characteristics—Average

- For 17.5kV Fuses:
- 17.5TDLSJ
 - 17.5THMEJ
 - 17.5TFLSJ
 - 17.5TKMEJ
 - 17.5TDMEJ

FUSE TYPES: TDL
TIME-CURRENT CHARACTERISTIC
FOR 17.5KV FUSE-LINKS

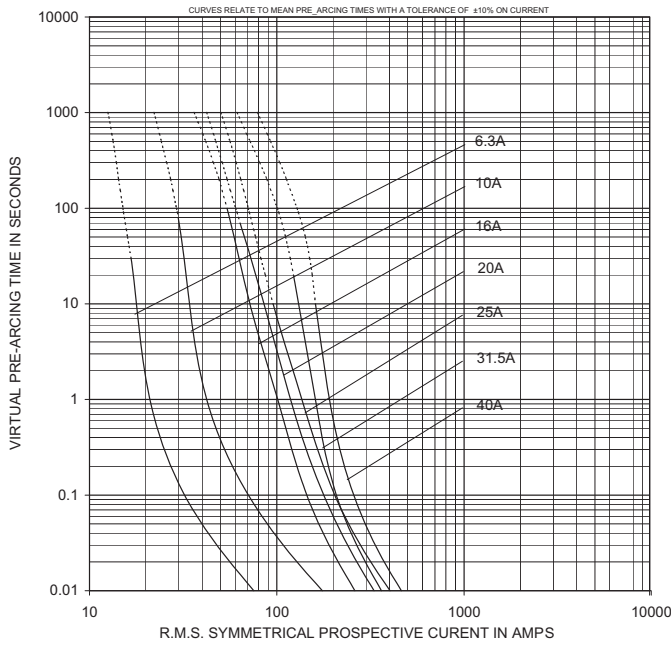

FUSE TYPES: TDM/THM/TKM
TIME-CURRENT CHARACTERISTIC
FOR 17.5KV FUSE-LINKS

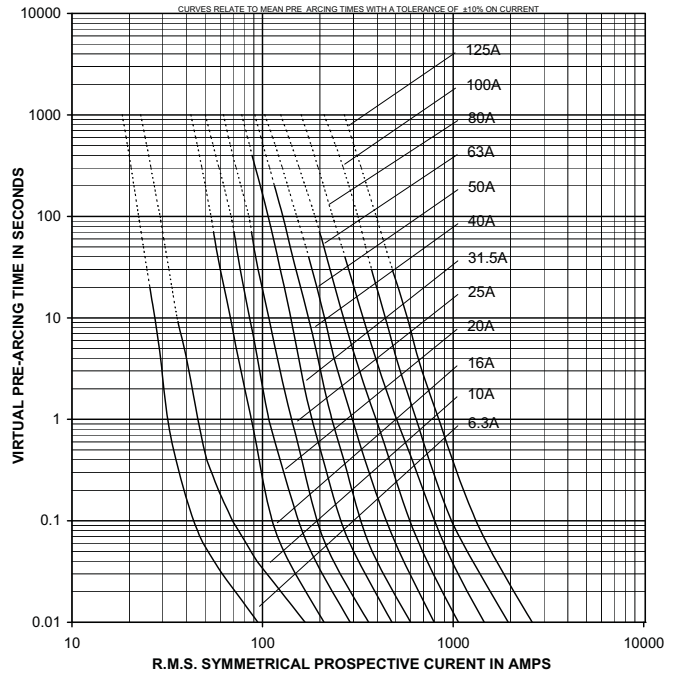

FUSE TYPES: TFL
TIME-CURRENT CHARACTERISTIC
FOR 17.5KV FUSE-LINKS

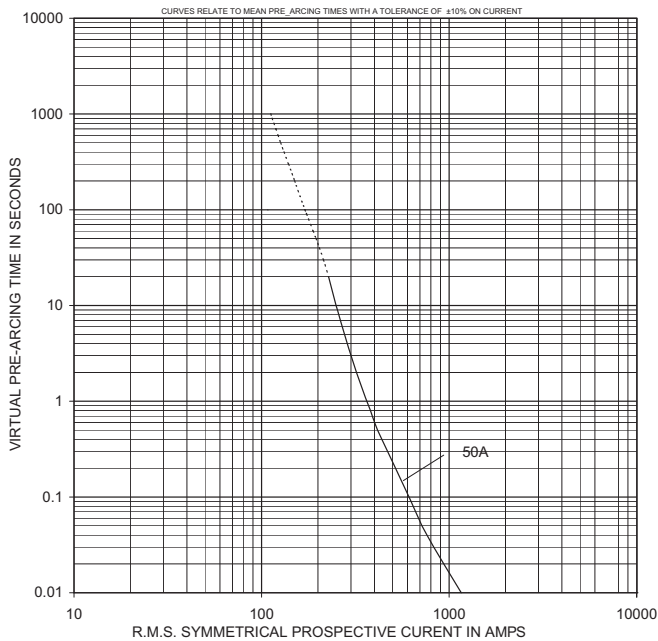

Average Time-Current Curves

For 24-27.6kV Fuses: • 24TDMEJ • 24TXMEJ
 • 24THMEJ
 • 24TFMEJ

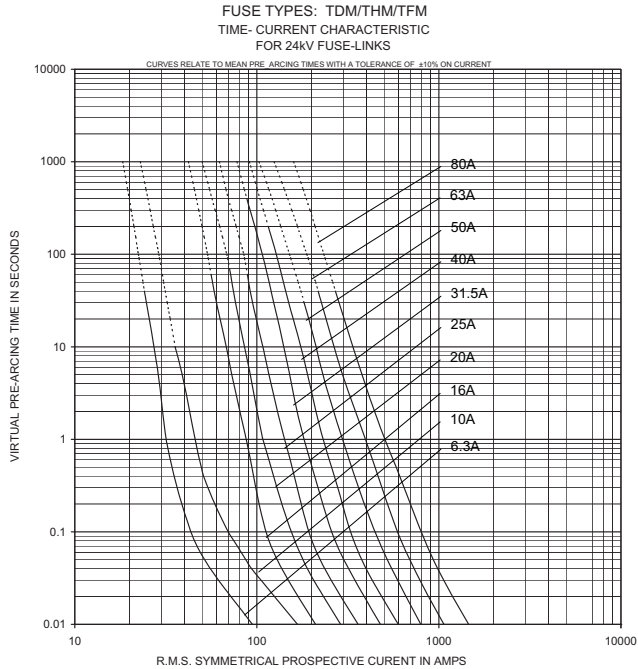

DIN Fuseclips

Suitable for use with all DIN HV fuses having 45mm end fittings.

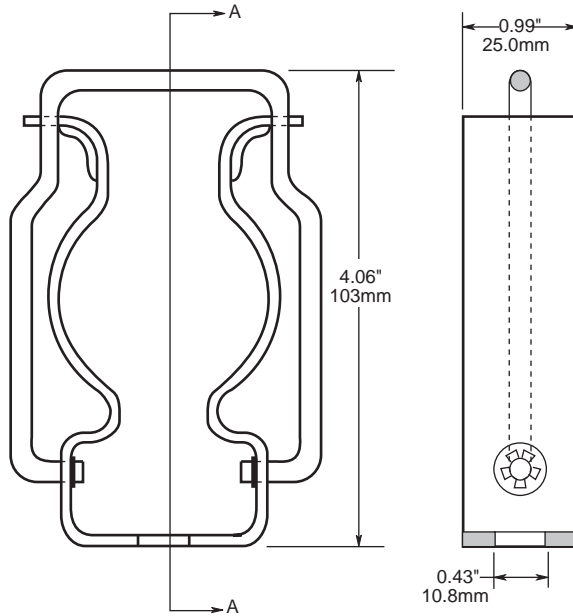

Part No. 270303
 For Standard Duty (up to 200A)

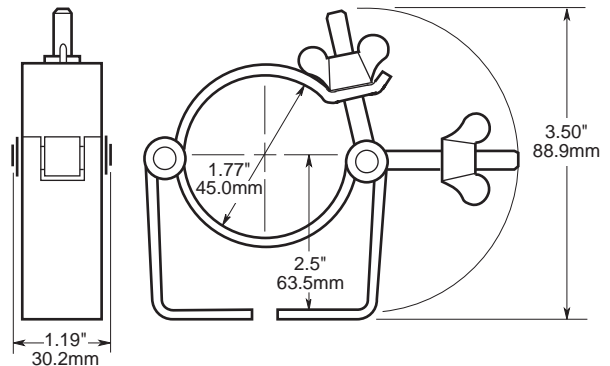
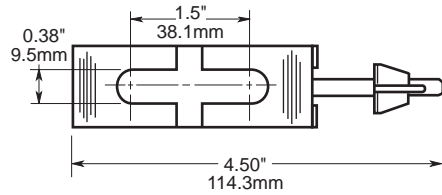
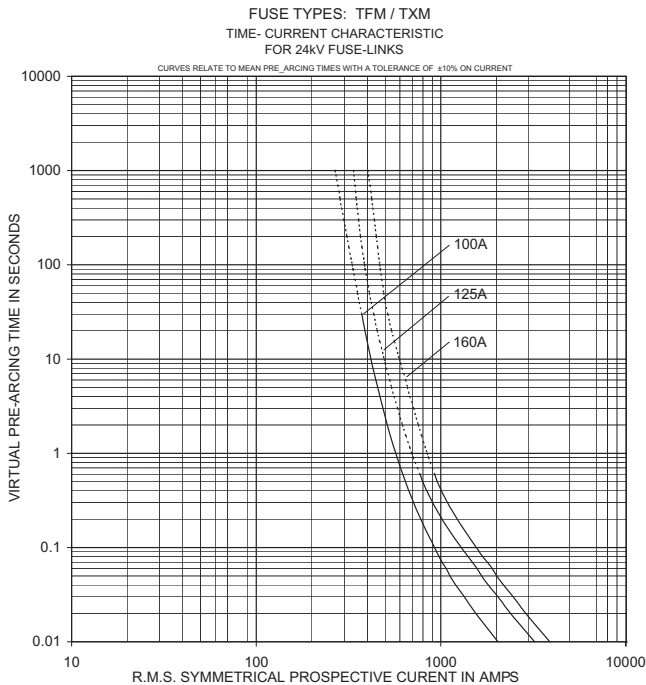

Part No. A3354745
 Heavy Duty

UL/CSA Fuses
 Current Limiting

UL/CSA Fuses
 General Purpose

Special
 Purpose Fuses

Canadian
 Fuses & Holders

Medium
 Voltage Fuses

Fuse Blocks,
 Holders & Misc.

Application
 Section

General Guide to the Selection of Fuses.

For use in the Primary Circuit of Three-Phase Transformers

Transformer 3-ph kVA	Fuse Reference and Rating in Amps													
	Fuse kV	3.6kV			7.2kV			12kV			17.5kV			24kV
System kV	2.4kV	4.16kV	6.9kV	10kV	12.47kV	13.2kV	13.8kV	15.5kV	20kV	24kV				
25	ADLSJ 16	TDLSJ 10	TDLSJ 6.3	TDLEJ 6.3	TDMEJ 6.3	TDMEJ 6.3	TDMEJ 6.3	TDMEJ 6.3	TDMEJ 6.3	TDMEJ 6.3				
30	ADLSJ 16	TDLSJ 10	TDLSJ 6.3	TDLEJ 6.3	TDMEJ 6.3	TDMEJ 6.3	TDMEJ 6.3	TDMEJ 6.3	TDMEJ 6.3	TDMEJ 6.3				
40	ADLSJ 20	TDLSJ 16	TDLSJ 10	TDLEJ 6.3	TDMEJ 6.3	TDMEJ 6.3	TDMEJ 6.3	TDMEJ 6.3	TDMEJ 6.3	TDMEJ 6.3				
45	ADLSJ 20	TDLSJ 16	TDLSJ 10	TDLEJ 6.3	TDMEJ 6.3	TDMEJ 6.3	TDMEJ 6.3	TDMEJ 6.3	TDMEJ 6.3	TDMEJ 6.3				
63	ADLSJ 31.5	TDLSJ 20	TDLSJ 16	TDLEJ 10	TDMEJ 10	TDMEJ 10	TDMEJ 6.3	TDMEJ 6.3	TDMEJ 6.3	TDMEJ 6.3				
75	ADLSJ 40	TDLSJ 25	TDLSJ 16	TDLEJ 10	TDMEJ 10	TDMEJ 10	TDMEJ 10	TDMEJ 10	TDMEJ 6.3	TDMEJ 6.3				
100	ADLSJ 40	TDLSJ 25	TDLSJ 20	TDLEJ 10	TDMEJ 10	TDMEJ 10	TDMEJ 10	TDMEJ 10	TDMEJ 10	TDMEJ 6.3				
112	ADLSJ 40	TDLSJ 31.5	TDLSJ 20	TDLEJ 16	TDMEJ 10	TDMEJ 10	TDMEJ 10	TDMEJ 10	TDMEJ 10	TDMEJ 6.3				
125	WDLSJ 50	TDLSJ 31.5	TDLSJ 25	TDLEJ 16	TDMEJ 10	TDMEJ 10	TDMEJ 10	TDMEJ 10	TDMEJ 10	TDMEJ 10				
150	WDLSJ 50	TDLSJ 40	TDLSJ 25	TDLEJ 16	TDMEJ 16	TDMEJ 16	TDMEJ 16	TDMEJ 10	TDMEJ 10	TDMEJ 10				
200	WDLSJ 63	TDLSJ 50	TDLSJ 31.5	TDLEJ 20	TDMEJ 16	TDMEJ 16	TDMEJ 16	TDMEJ 16	TDMEJ 10	TDMEJ 10				
225	WDLSJ 80	TDLSJ 50	TDLSJ 40	TDLEJ 20	TDMEJ 16	TDMEJ 16	TDMEJ 16	TDMEJ 16	TDMEJ 10	TDMEJ 10				
300	WDLSJ 100	TDLSJ 63	TDLSJ 40	TDLEJ 25	TDMEJ 20	TDMEJ 20	TDMEJ 20	TDMEJ 20	TDMEJ 16	TDMEJ 10				
400	WDLSJ 125	TDLSJ 80	TDLSJ 50	TDLEJ 31.5	TDMEJ 31.5	TDMEJ 25	TDMEJ 25	TDMEJ 20	TDMEJ 20	TDMEJ 20				
450	WFLSJ 160	TFLSJ 80	TDLSJ 63	TDLEJ 40	TDMEJ 31.5	TDMEJ 31.5	TDMEJ 31.5	TDMEJ 25	TDMEJ 20	TDMEJ 20				
500	WFLSJ 160	TFLSJ 100	TDLSJ 63	TDLEJ 40	TDMEJ 31.5	TDMEJ 31.5	TDMEJ 31.5	TDMEJ 31.5	TDMEJ 25	TDMEJ 20				
600	WFLSJ 200	TFLSJ 125	TFLSJ 80	TDLEJ 50	TDMEJ 40	TDMEJ 40	TDMEJ 40	TDMEJ 31.5	TDMEJ 25	TDMEJ 20				
750	WKLSJ 250	TFLSJ 160	TFLSJ 80	TDLEJ 63	TDMEJ 50	TDMEJ 50	TDMEJ 40	TDMEJ 40	TDMEJ 31.5	TDMEJ 25				
1000	WKLSJ 315	WKMSJ 200	TFLSJ 125	THLEJ 80	TDMEJ 63	TDMEJ 63	TDMEJ 63	TDMEJ 50	TDMEJ 40	TDMEJ 31.5				
1250	WKLSJ 400	WKMSJ 250	TSFLSJ 160	THLEJ 100	TDMEJ 80	TDMEJ 80	TDMEJ 80	TDMEJ 63	TDMEJ 50	TDMEJ 40				
1500	-	WKMSJ 315	TFLSJ 160	TKLEJ 125	TDMEJ 100	TDMEJ 100	TDMEJ 80	TDMEJ 80	THMEJ 63	TDMEJ 50				
2000	-	-	WKMSJ 250	-	TKMEJ 125	TKMEJ 125	TKMEJ 125	TDMEJ 100	-	-				
2500	-	-	WKMSJ 315	-	-	-	-	TKMEJ 125	-	-				

Selection of these fuses has been based on a compromise between the following:

1. The fuse should withstand transformer magnetizing inrush currents, taken as 12 times full load current for 0.1 second.
2. The fuse should coordinate with the highest rating of the secondary fuse likely to be used.
3. The fuse should operate reasonably quickly in the event of a transformer inter-turn fault or a fault in the secondary terminal zone of the transformer.

NOTES:

- A. In general, the recommendations apply equally to the use of fuse in open air or in an encapsulated enclosure, since "1" and "2" above dictate the use of a fuse current rating sufficiently above the transformer current rating to nullify any adverse thermal affect of encapsulation. However, if the transformer is subjected to long time overcurrents, a higher rate of fuse may be required.
- B. The above recommendations are not generally applicable to transformers feeding motor circuits with starting currents in excess of the rated current of the fuse. In this event, please consult your local Edison representative.
- C. Recommendations for other voltages are available on request.
- D. While the above recommendations give a good general guide, recommendations for specific cases will be sent on receipt of full details of the application.



Catalog Number H250 & H600 Series
Catalog Number R250 & R600 Series

Class H(K) and R Fuse Blocks:

H250 & H600 Series: For use with Class H and K5 Fuses
(Edison KON and ERN, H250;
Edison KOS and ERS, H600)

R250 & R600 Series: For use with Class R Fuses
(Edison LENRK and ECNR, R250;
Edison LESRK and ECSR, R600)

Construction: Thermoplastic, UL Flammability; 94V0

Amp Ratings: 1/10-600A

Voltage Ratings: H250, 250Vac; H600, 600Vac/dc; R250,
250Vac; R600, 600Vac

Agency Approvals:

UL Listed, Guide IZLT, File E14853
CSA, Class 6225-01, File 47235

Class H Fuseblocks (250V) Catalog Data (For Use With KON, ERN, PONC, and CDNC Fuses)

Amps	Poles	Terminal Type (Suffix No.)									Figure Number	Wire Range
		Screw				Box Lug w/						
		Catalog Number	—	Clip with Reinforced Spring	Pressure Plate	Pressure Plate & Clip with Reinforced Spring	—	Clip with Reinforced Spring	Copper Only	0.25 = Quick Connect		
1/10 to 30	1	H25030-1	S	SR	P	PR	C	CR	—	Q	1	C, CR #2-14 CU, #2-12 AL
	2	H25030-2	S	SR	P	PR	C	CR	—	—	2	P, PR #10-18 CU ONLY
	3	H25030-3	S	SR	P	PR	C	CR	—	—	3	Q N/A S, SR #10-18 CU ONLY
31 to 60	1	H25060-1	—	—	—	—	C	CR	CO	—	4	C, CR #2-14 CU, #2-8 AL CO #2-14 CU ONLY
	2	H25060-2	—	—	—	—	C	CR	CO	—	5	
	3	H25060-3	—	—	—	—	C	CR	CO	—	6	
61 to 100	1	H25100-1	—	SR	—	—	—	CR	—	—	7	CR #1/0-8 CU/AL SR #8W/ Ring Terminal
	2	H25100-2	—	SR	—	—	—	CR	—	—	8	
	3	H25100-3	—	SR	—	—	—	CR	—	—	9	
101 to 200	1	H25200-1	—	—	—	—	—	CR	—	—	10	CR 250kcmil-6 CU/AL
	3	H25200-3	—	—	—	—	—	CR	—	—	11	
201 to 400	1	H25400-1	—	—	—	—	—	CR*	—	—	12	CR 500kcmil-4 CU/AL
	3	H25400-3	—	—	—	—	—	CR†	—	—	13	
401 to 600	1	H25600-1	—	—	—	—	—	CR	—	—	14	CR (2) 500kcmil-4/0 CU/AL
	3	H25600-3	—	—	—	—	—	CR†	—	—	15	

*UL Recognized, No CSA Certification.

†No UL, No CSA Certification.

Class R Fuseblocks (250V) Catalog Data (For Use With ECNR, LENRK, and NCLR Fuses)

Amps	Poles	Catalog Number	Terminal Type (Suffix No.)					Fig. No.	Wire Range
			Screw w/		Box Lug w/		0.25"		
			—	Pres. Plate	—	Clip Cu Only	Quick-Connect		
1/10 to 30	1	R25030-1	SR	PR	CR	COR	QR*	1	COR #6-14 CU ONLY
	2	R25030-2	SR	PR	CR	COR	—	2	CR #2-14 CU, #2-12 AL
	3	R25030-3	SR	PR	CR	COR	—	3	PR #10-18 CU ONLY OR N/A SR #10-18 CU ONLY
31 to 60	1	R25060-1	—	—	CR	—	—	4	CR #2-14 CU, #2-8 AL
	2	R25060-2	—	—	CR	—	—	5	
	3	R25060-3	—	—	CR	—	—	6	
61 to 100	1	R25100-1	—	—	CR	—	—	7	CR 1/0-8 CU/AL
	2	R25100-2	—	—	CR	—	—	8	
	3	R25100-3	—	—	CR	—	—	9	
101 to 200	1	R25200-1	—	—	CR	—	—	10	CR 250kcmil-6 CU/AL
	3	R25200-3	—	—	CR	—	—	11	
201 to 400	1	R25400-1	—	—	CR†	—	—	12	CR 500kcmil-4/0 CU/AL
	3	R25400-3	—	—	CR†	—	—	13	
401 to 600	1	R25600-1	—	—	CR	—	—	14	CR 500kcmil-4/0 CU/AL
	3	R25600-3	—	—	CR†	—	—	15	

*UL Recognized, No CSA Certification.

†No UL, No CSA Certification.

‡UL Recognized, CSA Certification

Dimensions - in 250V 1/10 to 30A

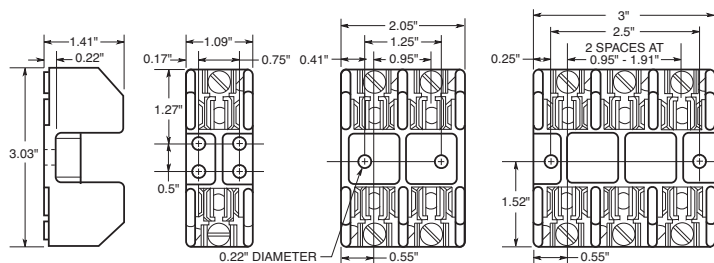

FIGURE 1.

FIGURE 2.

FIGURE 3.

250V, 31A to 60A

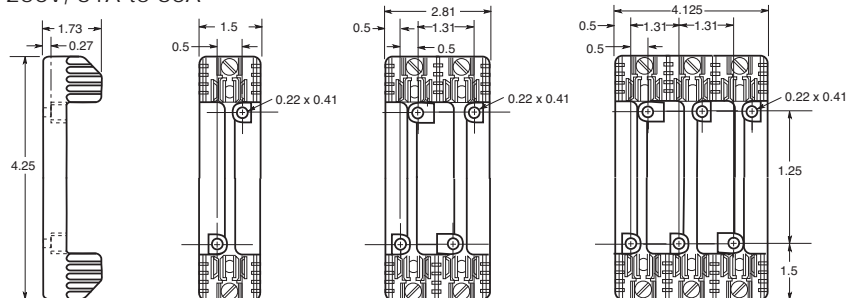

FIGURE 4.

FIGURE 5.

FIGURE 6.

250V, 61A to 100A

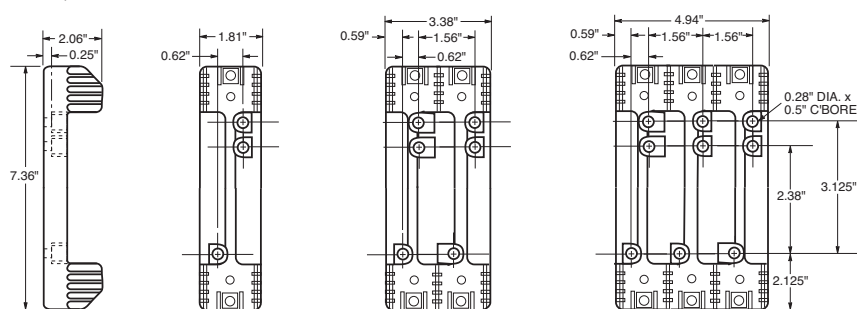

FIGURE 7.

FIGURE 8.

FIGURE 9.

250V, 101A to 200A

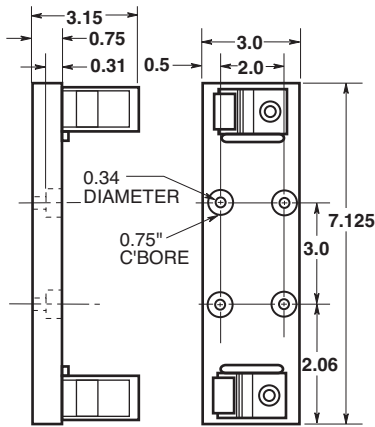

FIGURE 10.

250V, 101A to 200A

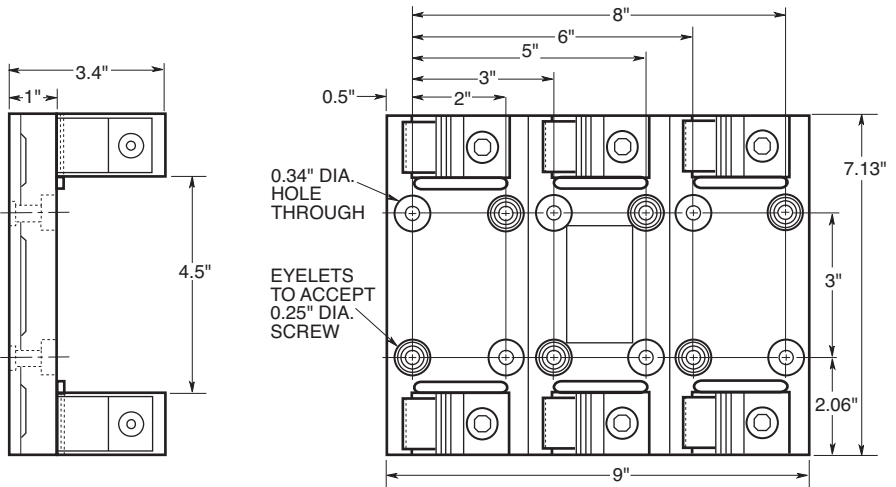

FIGURE 11.

250V, 201A to 400A

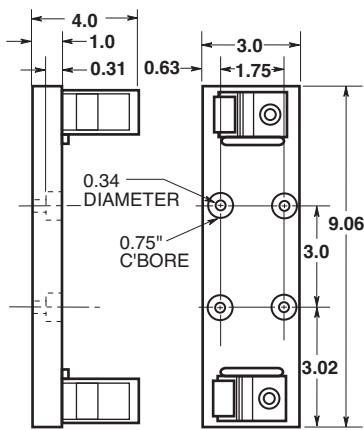

FIGURE 12.

250V, 201A to 400A

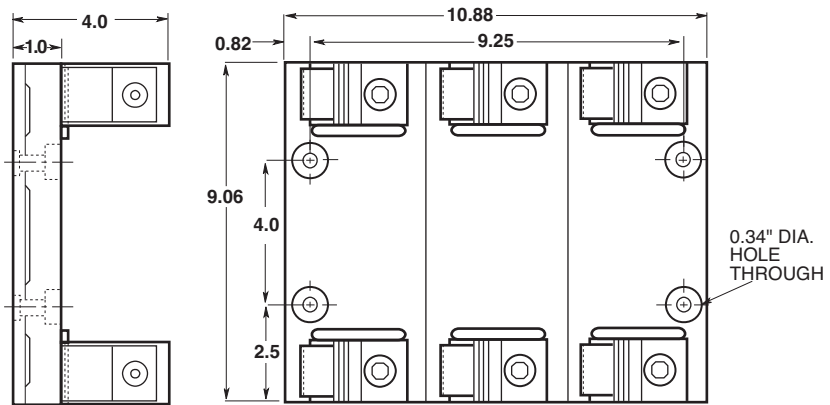

FIGURE 13.

250V, 401A to 600A

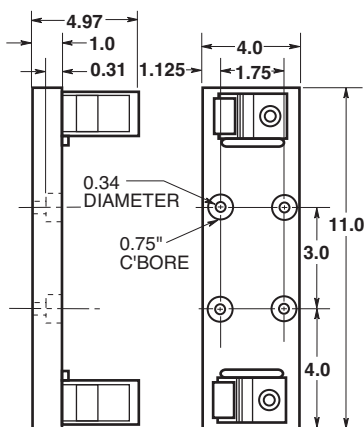

FIGURE 14.

250V, 401A to 600A

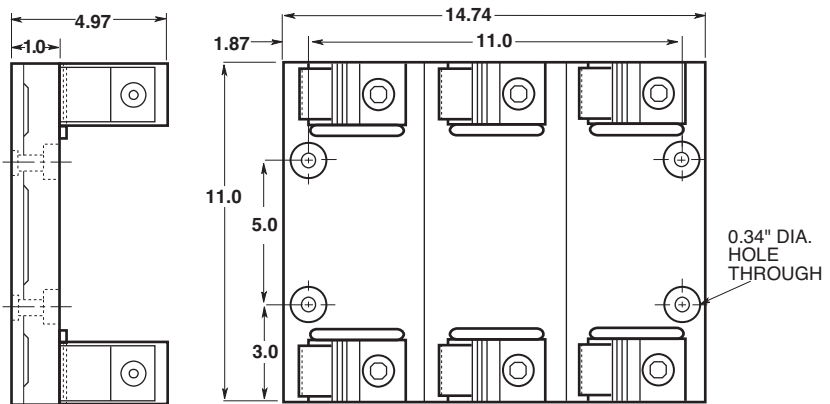

FIGURE 15.

Class H Fuseblocks (600V) Catalog Data (For Use With KOS, ERS, and CDSC Fuses)

Amps	Poles	Catalog Number	Terminal Type (Suffix No.)						Figure Number	Wire Range
			Screw			Box Lug w/				
			—	Clip with Reinforced Spring	Pressure Plate	Pressure Plate & Clip with Reinforced Spring	—	Clip with Reinforced Spring		
1/60 to 30	1	H60030-1	S	SR	P	PR	C	CR	1	C, CR #2-14 CU, #2-12 AL P, PR, S, SR #10-18 CU ONLY
	2	H60030-2	S	SR	P	PR	C	CR	2	
	3	H60030-3	S	SR	P	PR	C	CR	3	
31 to 60	1	H60060-1	—	—	—	—	C	CR	4	C, CR #2-14 CU, #2-8 AL
	2	H60060-2	—	—	—	—	C	CR	5	
	3	H60060-3	—	—	—	—	C	CR	6	
61 to 100	1	H60100-1	—	—	—	—	—	CR	7	CR #1/0-8 CU/AL
	2	H60100-2	—	—	—	—	—	CR	8	
	3	H60100-3	—	—	—	—	—	CR	9	
101 to 200	1	H60200-1	—	—	—	—	—	CR	10	CR 250kcmil-6 CU/AL
	3	H60200-3	—	—	—	—	—	CR	11	
201 to 400	1	H60400-1	—	—	—	—	—	CR†	12	CR 500kcmil-4 CU/AL
	3	H60400-3	—	—	—	—	—	CR†	13	
401 to 600	1	H60600-1	—	—	—	—	—	CR	14	CR (2) 500kcmil-4/0 CU/AL
	3	H60600-3	—	—	—	—	—	CR†	15	

†No UL, No CSA Certification.
‡UL Recognized, CSA Certification

Class R Fuseblocks (600V) Catalog Data (For Use With LESRK, ECSR, and SCLR Fuses)

Amps	Poles	Catalog Number	Terminal Type (Suffix No.)				Fig. No.	Wire Range
			Screw w/		Box Lug w/			
			—	Pres. Plate	—	Clip Cu Only		
1/60 to 30	1	R60030-1	SR	PR	CR	—	1	COR #6-14 CU ONLY CR #2-14 CU, #2-12 AL PR, SR #10-18 CU ONLY
	2	R60030-2	SR	PR	CR	COR	2	
	3	R60030-3	SR	PR	CR	COR	3	
31 to 60	1	R60060-1	—	—	CR	—	4	CR #2-14 CU, #2-8 AL
	2	R60060-2	—	—	CR	—	5	
	3	R60060-3	—	—	CR	—	6	
61 to 100	1	R60100-1	—	—	CR	—	7	CR, 1/0-8 CU/AL
	2	R60100-2	—	—	CR	—	8	
	3	R60100-3	—	—	CR	—	9	
101 to 200	1	R60200-1	—	—	CR	—	10	CR 250kcmil-6 CU/AL
	3	R60200-3	—	—	CR	—	11	
201 to 400	1	R60400-1	—	—	CR†	—	12	CR 500kcmil-4 CU/AL
	3	R60400-3	—	—	CR†	—	13	
401 to 600	1	R60600-1	—	—	CR	—	14	CR (2) 500kcmil-4/0 CU/AL
	3	R60600-3	—	—	CR†	—	15	

†No UL, No CSA Certification.
‡UL Recognized, CSA Certification

Dimensions – in
600V, 1/10 to 30A

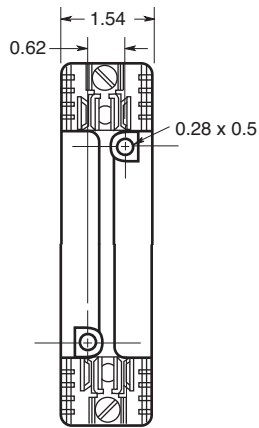
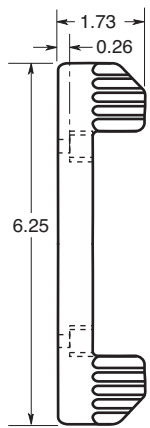

FIGURE 1.

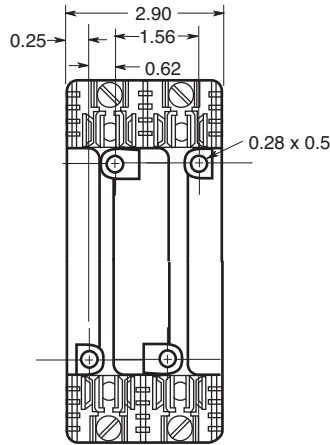

FIGURE 2.

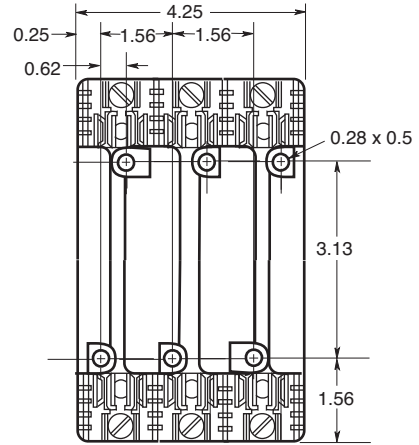

FIGURE 3.

600V, 31 to 60A

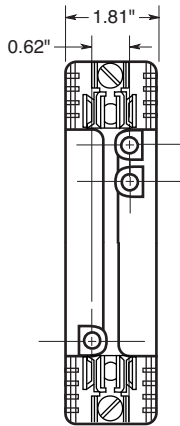
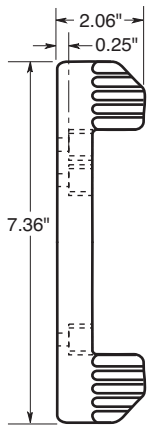

FIGURE 4.

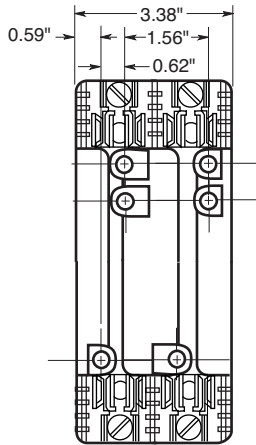

FIGURE 5.

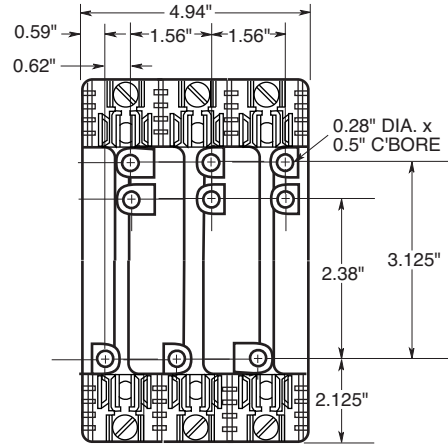

FIGURE 6.

600V, 61 to 100A

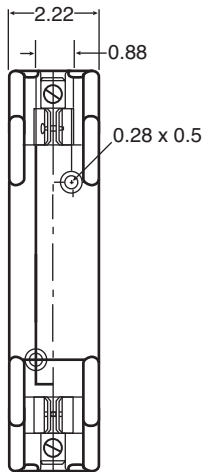
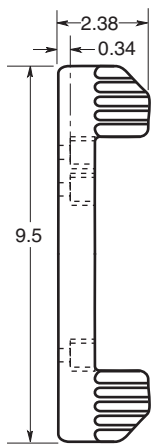

FIGURE 7.

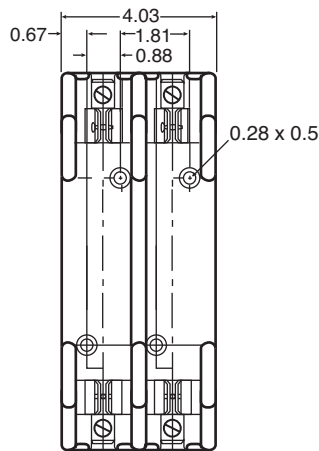

FIGURE 8.

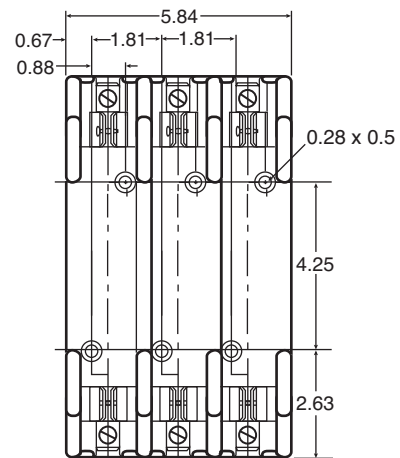

FIGURE 9.

UL/CSA Fuses
Current Limiting

UL/CSA Fuses
General Purpose

Special
Purpose Fuses

Canadian
Fuses & Holders

Medium
Voltage Fuses

Fuse Blocks,
Holders & Misc.

Application
Section

600V, 101 to 200A

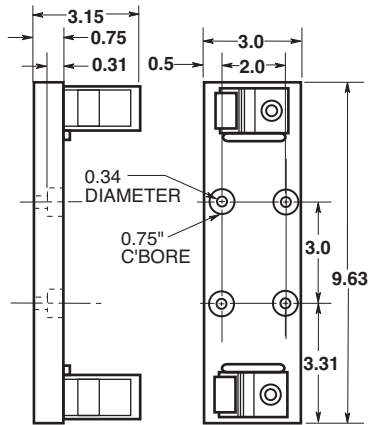

FIGURE 10.

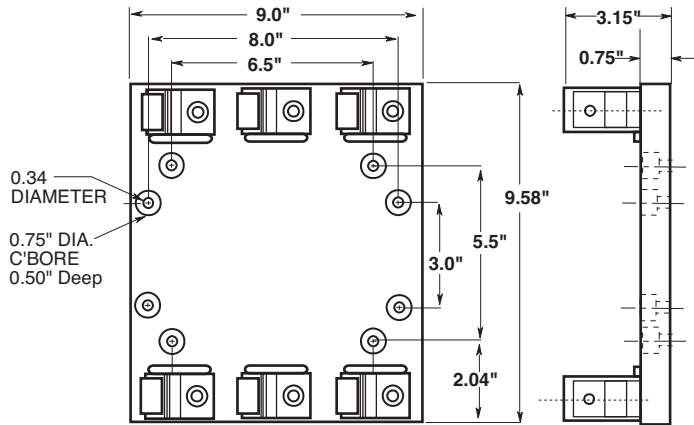

FIGURE 11.

600V, 201 to 400A

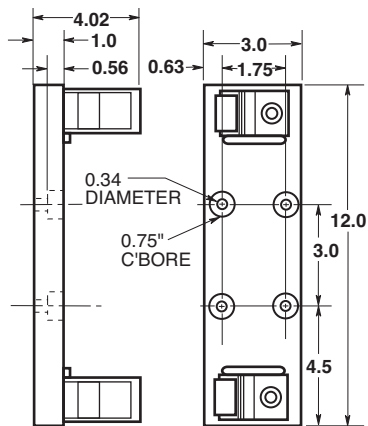

FIGURE 12.

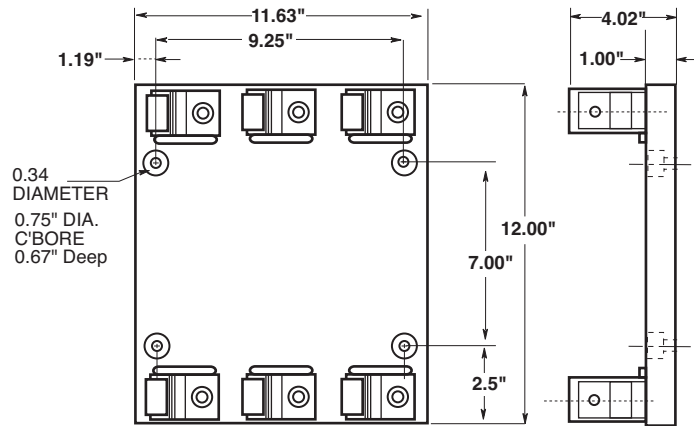

FIGURE 13.

600V, 401 to 600A

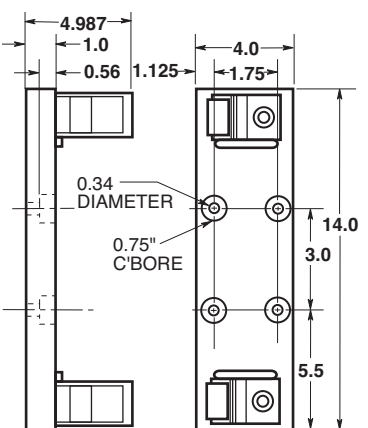

FIGURE 14.

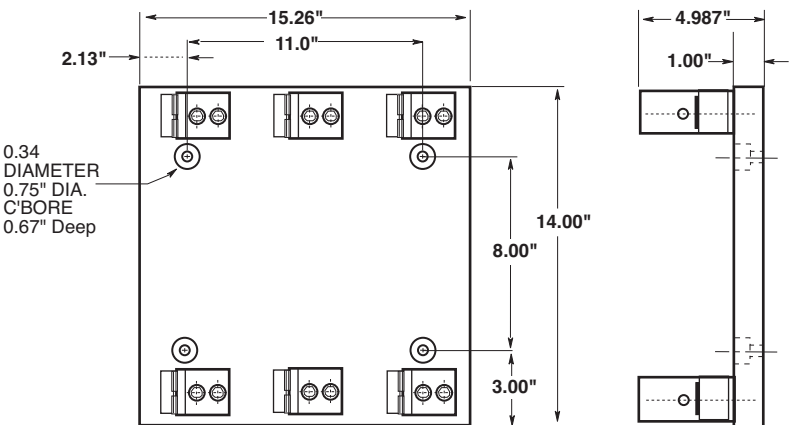

FIGURE 15.



Catalog Number J600 Series

Class J Fuse Blocks:

J600 Series: For use with Class J Fuses
(Edison JDL, JFL and CJ)

Construction: Thermoplastic, UL Flammability; 94V0

Amp Ratings: 1/2-600A

Voltage Ratings: 600Vac/dc

Agency Approvals:

UL Listed, Guide IZLT, File E14853
CSA, Class 6225-01, File 47235

Standard J Fuse Blocks (600V) Catalog Data

Amps	Poles	Catalog Numbers				Fig. No.	Max. Wire Size
		Screw†	Pressure Plate†	Box Lug	Box Lug w/ Retaining Clip		
1/2-30	1	J60030-1S	J60030-1P	J60030-1C	J60030-1CR††	1	C, CR#2-14 CU, #2-8 AL
	2	J60030-2S	J60030-2P	J60030-2C	J60030-2CR††	2	COR #2-14 CU only
	3	J60030-3S	J60030-3P	J60030-3C	J60030-3CR††	3	P, PR, S, SR #10-14 CU Only
31-60	1	—	—	J60060-1C	J60060-1CR††	1	C, CR, #2-14 CU/AL
	2	—	—	J60060-2C	J60060-2CR††	2	COR #4-14
	3	—	—	J60060-3C	J60060-3CR††	3	CU only
61-100	3	—	—	—	J60100-3CR††	4	COR 1/0-8 CU Only CR, CRO 1/0-8 CU/AL
to 200	1	—	—	—	J60200-1CR	5	CR 250kcmil-6 CU/AL
					J60200-3CR		
to 400	1	—	—	—	J60400-1CR	7	CR 500kcmil -4 CU/AL
					J60400-3CR		
to 600	1	—	—	—	J60600-1CR	9	CR (2) 500kcmil-4/0 CU/AL
					J60600-3CR		

† Clip reinforcing springs are standard on fuse blocks rated 100A and above. Available on 30A and 60A blocks by adding the letter "R" to the end of the part number.

††Copper only connections available by changing "CR" suffix to "COR".

Dimensions - inches

1/2 to 60A

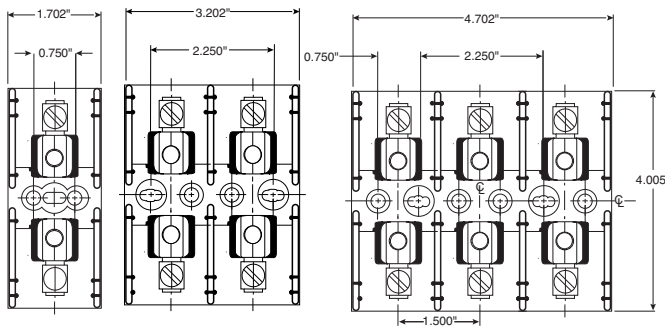

Figure 1.

Figure 2.

Figure 3.

61 to 100A

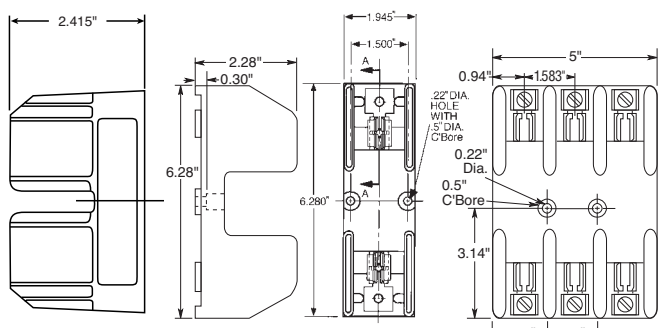

Figure 4.

Figure 5.

101- 200A

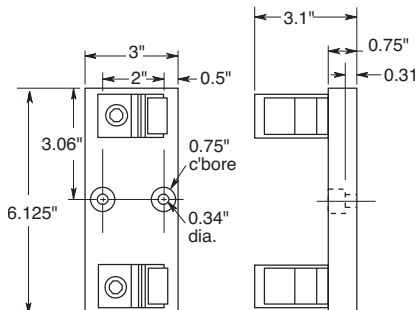

Figure 5.

201- 400A

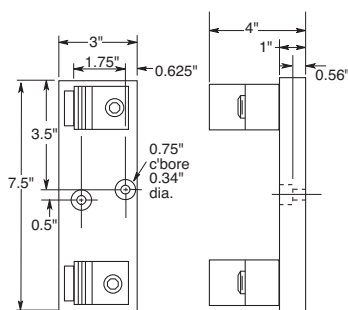

Figure 6.

401-600A

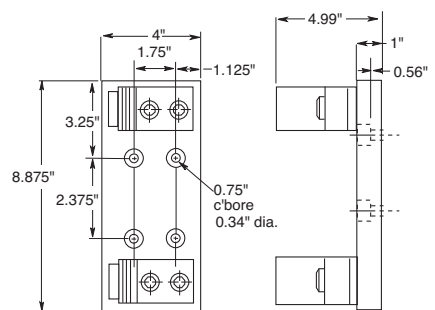
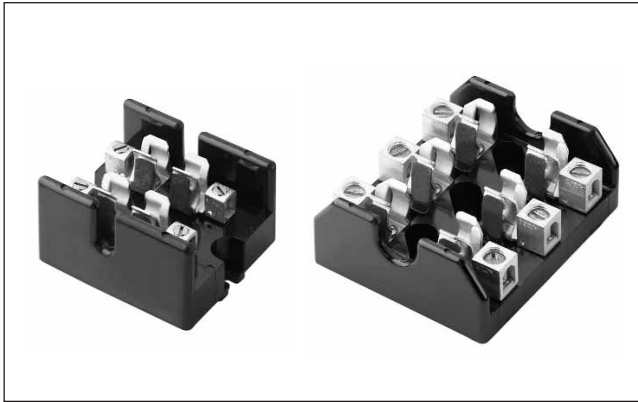

Figure 7.



Class T Fuse Blocks:

T300 Series: For use with Class T Fuses
(Edison TJN)

T600 Series: For use with Class T Fuses
(Edison TJS)

Construction: Glass Polyester, Phenolic on 600A,
UL Flammability: 94V0

Ratings: **T300:** 300Vac/dc, 30 - 600A
T600: 600Vac/dc, 30 - 600A

Agency Approvals:

UL Listed, Guide IZLT, File E14853
CSA, Class 6225-01, File 47235

Dimensions - inches
Figure 1. 300V 1/2A to 60A

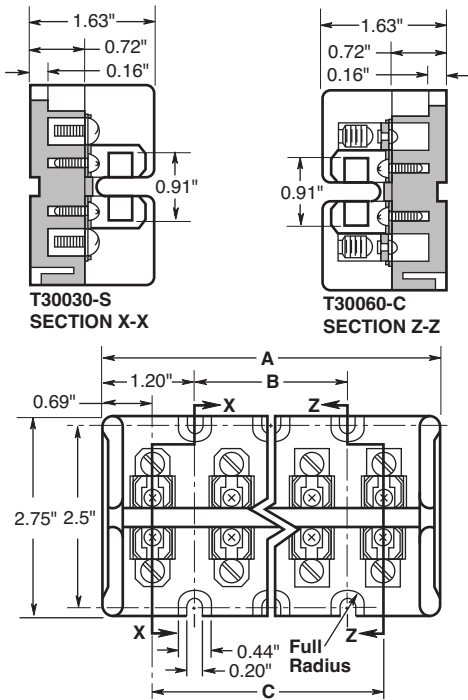

Terminal Type	Dimensions (inches)		
	A	B	C
T30030-2	2.41	—	1.03
T30060-2	2.41	—	1.03
T30030-3	3.44	1.03	2.06
T30060-3	3.44	1.03	2.06
T30030-4	4.47	2.06	3.09
T30060-4	4.47	2.06	3.09

Figure 2. 600V 1/2A to 30A

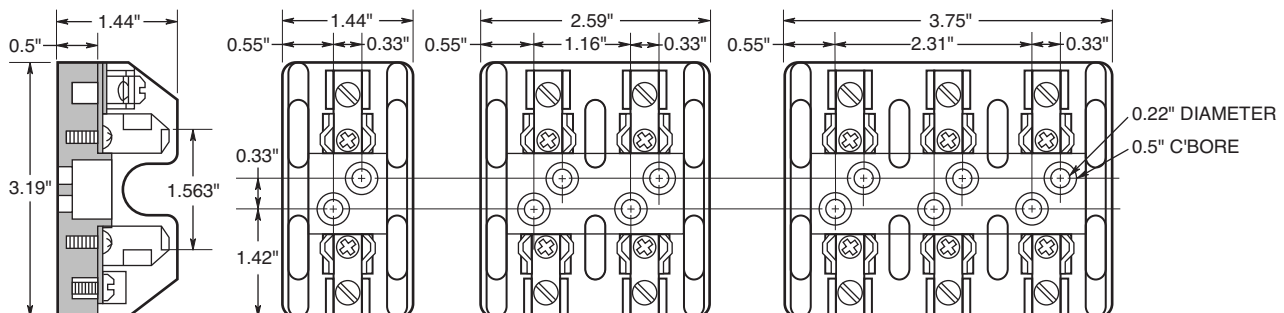

Class T Fuse Blocks (300V & 600V) Catalog Data

Amps	Poles	Catalog Numbers			Max. Wire Size
		Screw	Box Lug	Fig. No.	
TJN, 300V					
1/2-30	2	T30030-2SR	T30030-2CR	1	SR #10Cu;
	3	T30030-3SR	T30030-3CR	1	CR #2Cu-Al
31-60	2	T30060-2SR*	T30060-2CR	1	#2Cu Al
	3	T30060-3SR*	T30060-3CR	1	
61-100	4	T30060-4SR*	T30060-4CR	1	1/0 Cu-Al
	1	—	T30100-1C	4	
to 200	2	—	T30100-2C	4	250MCM Cu-Al
	3	—	T30100-3C	4	
to 400	1	—	T30200-1C	5	600MCM Cu-Al
	3	—	T30200-3C	5	
to 600	1	—	T30400-1C	6	(2) 600MCM Cu-Al
	3	—	T30600-1C	7	
TJS, 600V					
1/2-30	1	T60030-1SR	T60030-1CR	2	SR #10Cu;
	2	T60030-2SR	T60030-2CR	2	
31-60	3	T60030-3SR	T60030-3CR	2	CR#2Cu Al
	1	T60060-1SR*	T60060-1CR	3	
61-100	2	T60060-2SR	T60060-2CR	3	2/0 Cu-Al
	3	T60060-3SR*	T60060-3CR	3	
to 200	1	—	T60100-1C	4	250MCM Cu-Al
	2	—	T60100-2C	4	
to 400	2	—	T60100-3C	4	600MCM Cu-Al
	1	—	T60200-1C	5	
to 600	1	—	T60400-1C	6	(2) 600MCM Cu-Al
	3	—	T60600-1C	7	

* U.L. Recognized

Dimensions - inches
Figure 3. 600V 31 to 60A

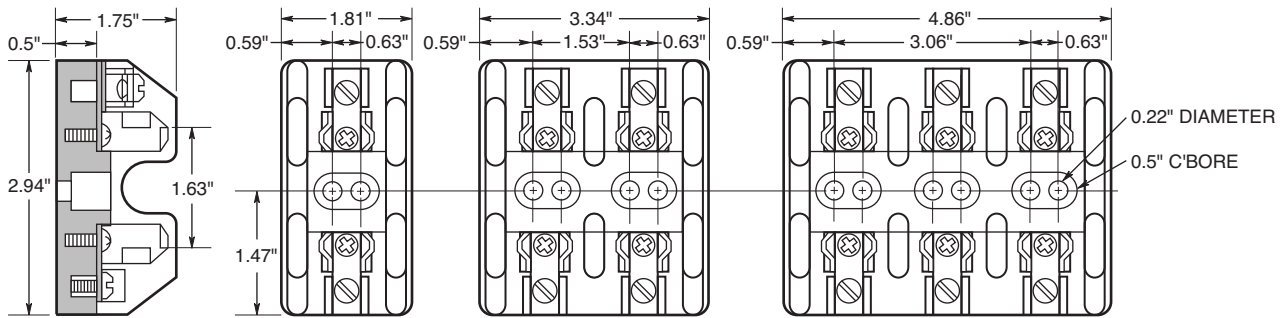
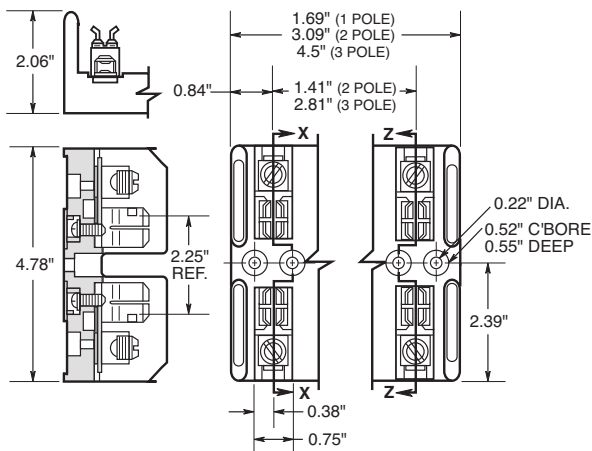

Figure 4. 300V, 61 to 100A



600V, 61 to 100A

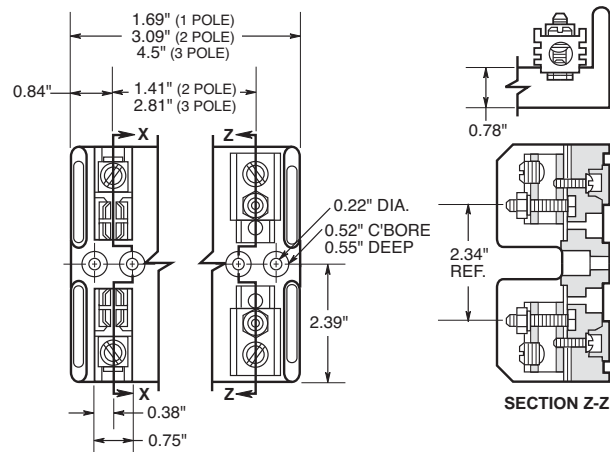

Figure 5. 300V, 600V 101 to 200A

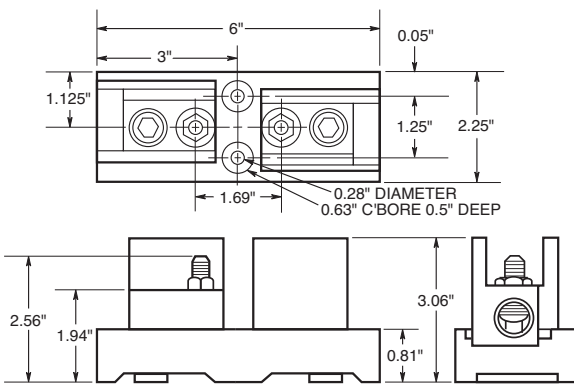

Figure 6. 300V, 600V 201 to 400A

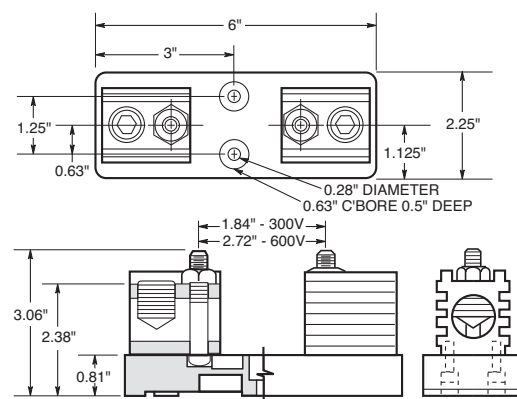
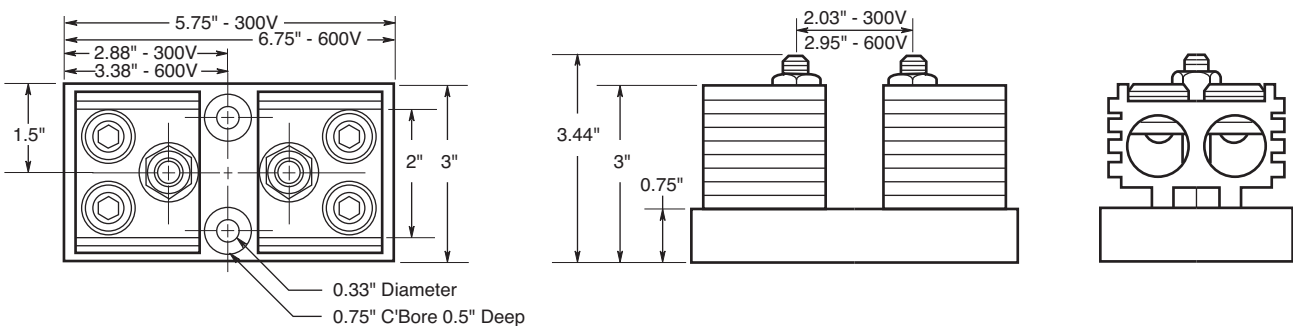
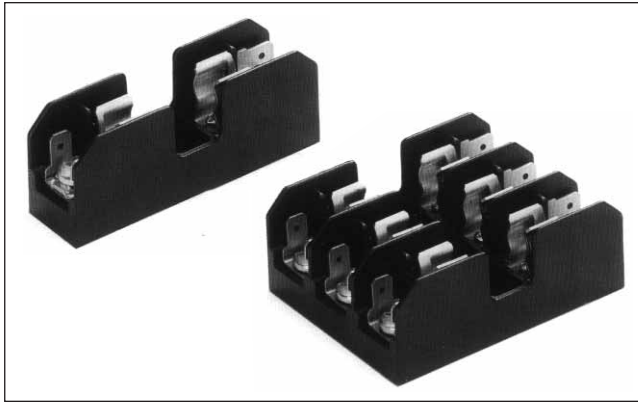

Figure 7. 300V, 600V 401 to 600A





Catalog Number BG Series and G Series

Class G Fuse Blocks:
BG Series and G Series: For use with Class G Fuses
(Edison SEC)

Construction: (0-30A) Thermoplastic
(35-60A) Phenolic

Amp Ratings: 1-60A
UL Listed, Guide IZLT,
File E14853

Voltage Ratings: 600V (0-20A)
480V (25-60A)

Agency Approvals: CSA, Class 6225-01, File 47235

Catalog Data

Amps	Poles	Terminal Type				Fig. No.
		Screw with Quick-Connect	Pressure Plate w/Quick Connect	Box Lug	Box Lug w/ Clip	
1 to 15	1	BG3011SQ	BG3011PQ	BG3011B	—	1
	2	BG3012SQ	BG3012PQ	BG3012B	—	2
	3	BG3013SQ	BG3013PQ	BG3013B	—	3
20	1	BG3021SQ	BG3021PQ	BG3021B	—	1
	2	BG3022SQ	BG3022PQ	BG3022B	—	2
	3	BG3023SQ	BG3023PQ	BG3023B	—	3
25 to 30	1	BG3031S	BG3031P	BG3031B	—	1
	2	BG3032S	BG3032P	BG3032B	—	2
35 to 60	3	BG3033S	BG3033P	BG3033B	—	3
	1	—	—	—	G30060-1CR	4
	2	—	—	—	G30060-2CR	4
60	3	—	—	—	G30060-3CR	5

Dimensions - inches

1 to 30A

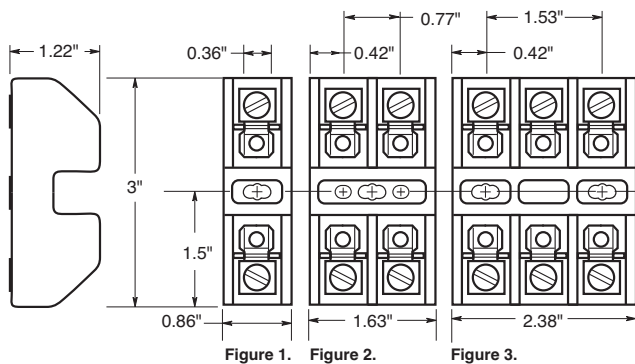

Figure 1. Figure 2. Figure 3.

Dimensions - inches

35 to 60A

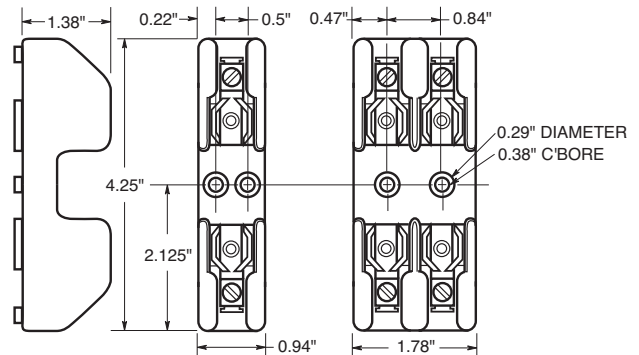

Figure 4.

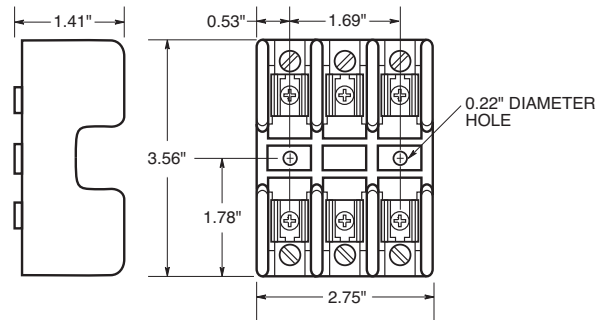
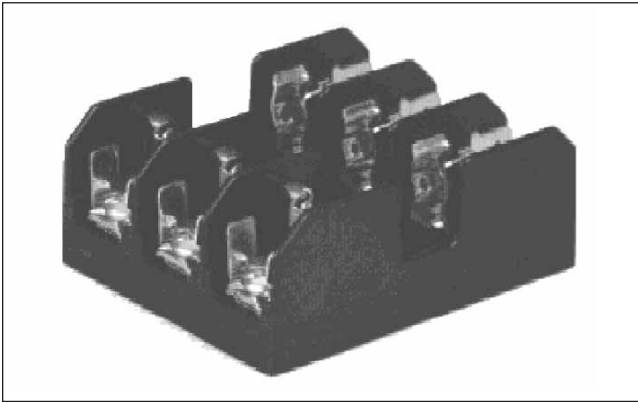

Figure 5.

CROSS REFERENCE		
EDISON	GOULD	LITTELFUSE
BG3011SQ	NONE	LG30015-1SQ
BG3012SQ	NONE	LG30015-2SQ
BG3013SQ	NONE	LG30015-3SQ
BG3021SQ	NONE	LG30020-1SQ
BG3022SQ	NONE	LG30020-2SQ
BG3023SQ	NONE	LG30020-3SQ
BG3031S	NONE	LG30030-1SQ
BG3032S	NONE	LG30030-2SQ
BG3033S	NONE	LG30030-3SQ
BG3011PQ	NONE	NONE
BG3012PQ	NONE	NONE
BG3013PQ	NONE	NONE
BG3021PQ	NONE	NONE
BG3022PQ	NONE	NONE
BG3023PQ	NONE	NONE
BG3031P	NONE	LG30030-1PQ
BG3032SP	NONE	LG30030-2PQ
BG3033P	NONE	LG30030-3PQ
BG3011B	NONE	NONE
BG3012B	NONE	NONE
BG3013B	NONE	NONE
BG3021B	NONE	NONE
BG3022B	NONE	NONE
BG3023B	NONE	NONE
BG3031B	NONE	NONE
BG3032B	NONE	NONE
BG3033B	NONE	NONE
G30060-1CR	NONE	LG30060-1CR
G30060-2CR	NONE	LG30060-2CR
G30060-3CR	NONE	LG30060-3CR



Catalog Number BC Series

Class CC Fuse Blocks:

BC Series: For use with Class CC Fuses (Edison EDCC, HCTR, and HCLR)

Construction: Base - Thermoplastic
Clips - Bright Tin-plated Bronze
UL Flammability; 94V0

Ratings: 600Vac/dc, 30A

Agency Approvals:

UL listed Guide IZLT, File 14853
CSA, Class 6225-01, File 47235

Catalog Data

	Poles	Terminal Type		
		Screw with Quick Connect	Pressure Plate w/ Quick Connect	Box Lug
1/10 to 30	1	BC6031SQ	BC6031P	BC6031B
	2	BC6032SQ	BC6032P	BC6032B
	3	BC6033SQ	BC6033P	BC6033B



CROSS REFERENCE			
NEW EDISON	OLD EDISON	GOULD	LITTELFUSE
BC6031SQ	EMR631-66	30311R	L60030C-1SQ
BC6032SQ	EMR632-66	30312R	L60030C-2SQ
BC6033SQ	EMR633-66	30313R	L60030C-3SQ
BC6031PQ	EMR631-77	30321R	L60030C-1PQ
BC6032PQ	EMR632-77	30322R	L60030C-2PQ
BC6033PQ	EMR633-77	30323R	L60030C-3PQ
BC6031B	EMR631-11	30351R	L60030C-1B
BC6032B	EMR632-11	30352R	L60030C-2B
BC6033B	EMR633-11	30353R	L60030C-3B

Dimensions - inches (mm)

1 POLE

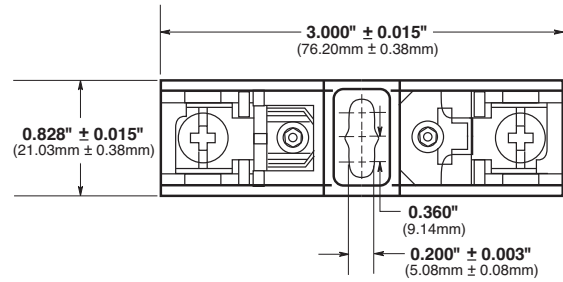

2 POLE

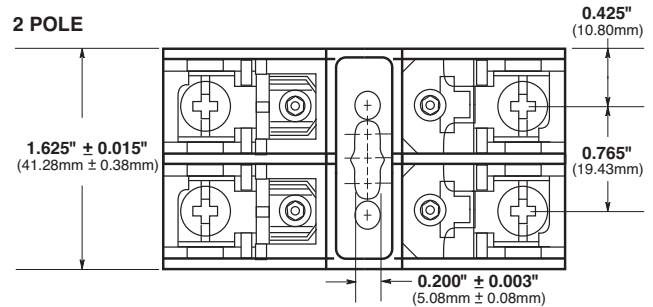

3 POLE

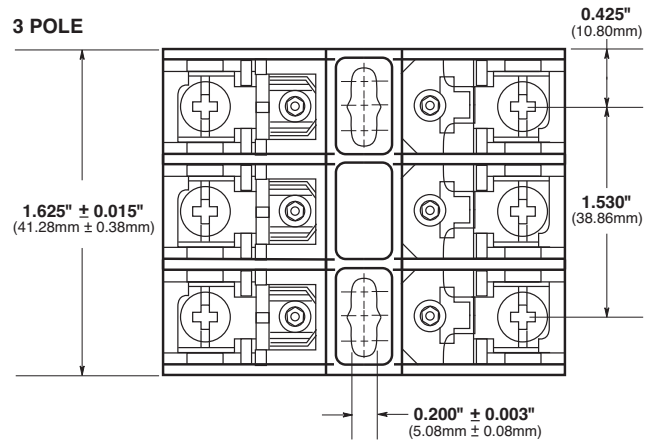

Fuse Block

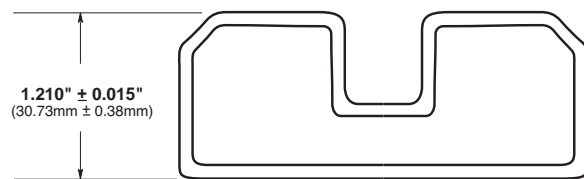



Catalog Number BM Series

Class M Supplementary Fuse Blocks:

BM Series: For use with any 1 1/2" x 1 1/2" fuses (Edison MCL, MEQ, MEN, and MOL)

Construction: Thermoplastic, UL Flammability; 94V0
Ratings: 600Vac/dc, 30A

Agency Approvals:
UL Recognized, Guide IZLT2, File E14853
CSA, Class 6225-01, File 47235

Catalog Data (600Vac)

Amps	Poles	Terminal Type			Fig. No.
		Screw with Quick Connect	Pressure Plate w/ Quick Connect	Box Lug	
1/10 to 30	1	BM6031SQ	BM6031PQ	BM6031B	1
	2	BM6032SQ	BM6032PQ	BM6032B	2
	3	BM6033SQ	BM6033PQ	BM6033B	3

Dimensions - inches (mm)

1/10 to 30A

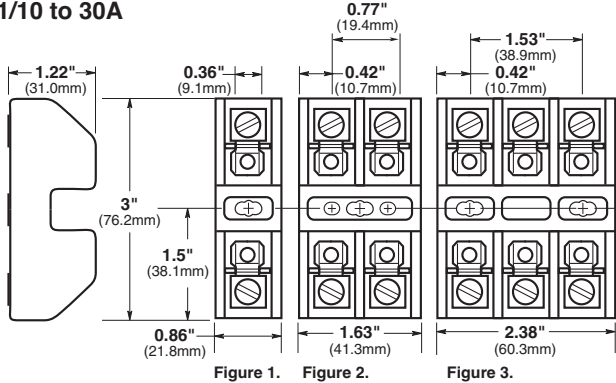

Figure 1. Figure 2. Figure 3.

CROSS REFERENCE

NEW EDISON	OLD EDISON	GOULD	LITTELFUSE
BM6031SQ	EM631-33	30311	L60030M-1SQ
BM6032SQ	EM632-33	30312	L60030M-2SQ
BM6033SQ	EM633-33	30313	L60030M-3SQ
BM6031PQ	EM631-44	30321	L60030M-1PQ
BM6032PQ	EM632-44	30322	L60030M-2PQ
BM6033PQ	EM633-44	30323	L60030M-3PQ
BM6031B	EM631-11	30351	L60030M-1B
BM6032B	EM632-11	30352	L60030M-2B
BM6033B	EM633-11	30353	L60030M-3B



Adapter for DIN and American Rails

Features:

- Edison DIN rail adapters permit secure, positive snap-on mounting of Edison 0 to 30 amp fuse blocks (one-, two-, or three-pole) on various size rails. (rail mounting eliminates costly and time consuming drilling, tapping, and screw mounting.)
- Molded from Lexan® 141.
- Adapter mechanically locks into mounting hole of fuse block in seconds to become an integral part of the block.
- One adapter is required for Edison one- and two-pole blocks. Two adapters are required for three-pole blocks.
- With the exception of the 32mm DIN rail, all blocks with adapters can be removed from a rail simply by pulling up its release tab.
- Use of rail end-stops on both sides of adapters is recommended.

Adapter Catalog Data (For 0-30A Fuse Blocks)

Fuse Block Class	Rails		Adapter	
	Type	Size	Color	Cat. No.
CC G *H (250V)	DIN	15mm (Symm.) 32mm (Asymm.) 35mm (Symm.)	Black	DRA-1
*R (250) M Type	American	17/64" (Symm.) (also 35mm DIN)	Gray	DRA-2

Package Quantities: Standard - 10; Bulk - 100 (Cat. No. BK/DRA-1 or BK/DRA-1.)

*Mounting on 15mm rails is not recommended.

NOTE: New model Edison fuse blocks have elongated block-to-adapter mounting holes (old style fuse blocks will not accept the rail adapters).



Block Series:

BH Series: For use with Edison high speed semiconductor and "bolt-in" fuses

Base: Light weight, high temperature thermoplastic

Mounting Studs: Plated steel

Nut: Plated steel

Washer: Spring steel

Agency Approvals:

UL Recognized, Guide IZLT2/IZLT8, File E14853 up to 700V
CSA, Class 6225-01, File 47235 up to 700V

Contact Edison Customer Satisfaction for ordering information and dimensional data.

Catalog Number BH Series

Catalog Code Description:
Block Series

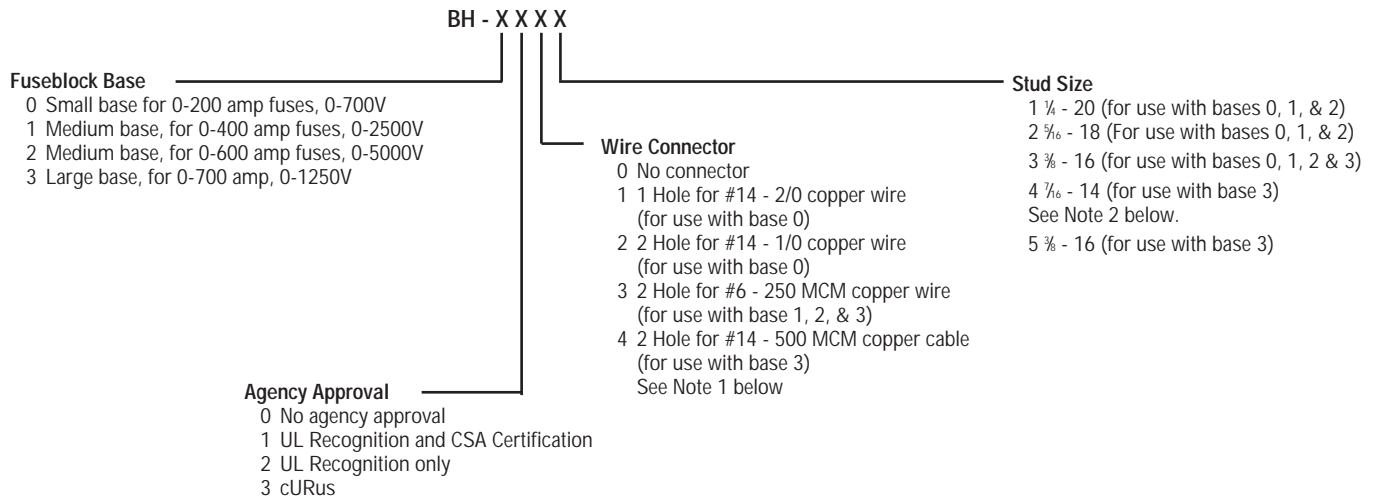

- NOTES:**
1. The #4 connector must be used with either the 7/16" - 14 or the 3/8" - 16 stud.
 2. The only compatible connector for the 7/16" - 14 stud is #4.
 3. Always check applicable end use standards for required spacing between blocks, fuses or other hardware.
 4. For applications above 700V, consult appropriate electrical standard for proper creepage distances, clearance distances and insulator voltage withstand ratings.

Catalog Numbers

BH-0001	BH-0122	BH-2001	BH-3004
BH-0002	BH-1001	BH-2002	BH-3033
BH-0003	BH-1002	BH-2003	BH-3144
BH-0111	BH-1003	BH-2031	BH-3145
BH-0112	BH-1131	BH-2032	—
BH-0113	BH-1132	BH-2033	—
BH-0121	BH-1133	BH-3003	—

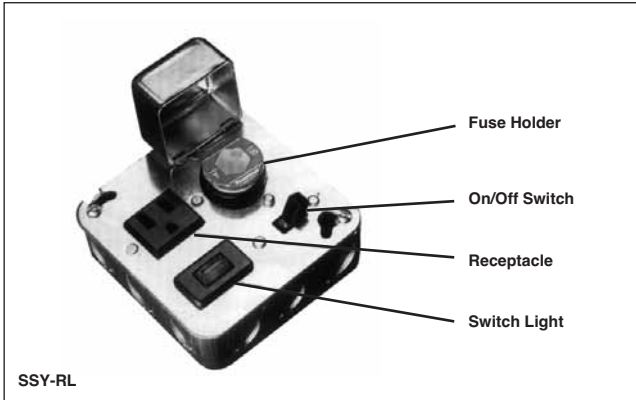

Box Cover Units

For Plug Fuses

Plug fuse box cover units provide a simple, inexpensive way to protect small motors with Edison-type “T”, “TL”, “TC”, “P” and “W” plug fuses. Box cover units are easily installed in standard electrical boxes. By using fuses sized at the amp rating of a motor or slightly larger, optimum overload and short-circuit protection is provided. Box cover units are UL Listed.

Selection Data – Plug Fuse Box Cover Units

Box Cover Cat. No.	Type Box	Fuseholder		Receptacle Outlet to Load		Switch Control+	Switch Light++	Motor Size (Max.)	General Data	Agency† Listing/ Certification	
		Single	Double	125Vac	250Vac						
SOU	2 1/2" Handy	X						3/4 Hp	125V, 15A	UL, CSA	
SRU		X		X				1/2 Hp	125V, 15A	UL	
SSU		X					X		1/2 Hp	125Vac (do not use on DC), 15A	UL, CSA
SOW	2 3/4" Switch	X						3/4 Hp	125V, 15A	UL, CSA	
SRW		X		X				1/2 Hp	125V, 15A	UL	
SSW		X					X		1/2 Hp	125Vac (do not use on DC), 15A	UL, CSA
SOX	4" Octagon	X						3/4 Hp	125V, 15A	UL, CSA	
SRX		X		X				1/2 Hp	125V, 15A	UL	
SSX		X					X		1/2 Hp	125Vac (do not use on DC), 15A	UL, CSA
SOY	4" Square	X						3/4 Hp	125V, 15A	UL, CSA	
SRY		X		X				1/2 Hp	125V, 15A	UL	
SSY		X					X		1/2 Hp	125Vac (do not use on DC), 15A	UL, CSA
SSY-RL		X		X	X		X	X	1/2 Hp	125Vac (do not use on DC), 15A	—
STY*			X				X*		1/2 Hp*	125Vac (do not use on DC)*, 15A	UL
SCY**			X			X(2)**		1/2 Hp(2)**	125Vac (do not use on DC); can protect two motors**, 15A	UL	
SOY-B			X					3/4 Hp	125V, protects two motors, 15A	UL	
SKA	4 1/8" Square		X					2 Hp	250V, 15A single-phase	UL	
SSN	Single Gang	X				X		1/2 Hp	125V, 15A Weatherproof	UL	

+ Switch turns power to fused load OFF or ON.

++ Switch light indicates power to load (dark when switch OFF or fuse open).

* Double-pole switch opens both sides of circuit. STY can be used for two separate 125V motors not larger than 1/2 Hp with the common switch, or a single motor not larger than 2 Hp at 250V (Maximum of 150V to ground).

** The SCY unit can be used for protection of a single motor not larger than 2Hp at 250V (Maximum of 150V to ground).

† UL Guide JAMZ, File E6491; CSA Class 6225-01, File 47235.

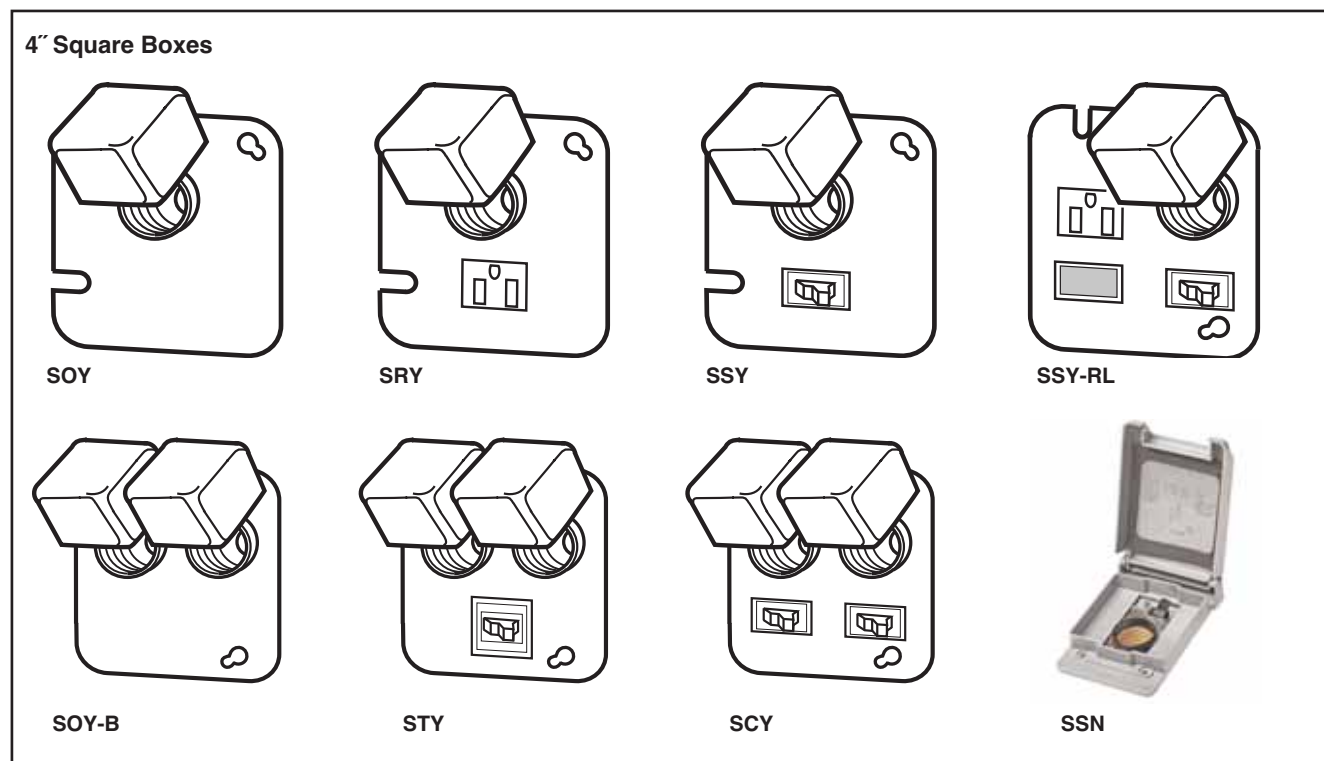
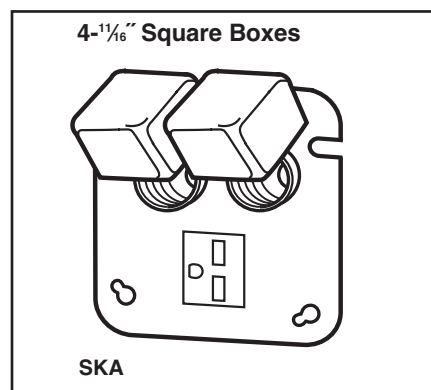
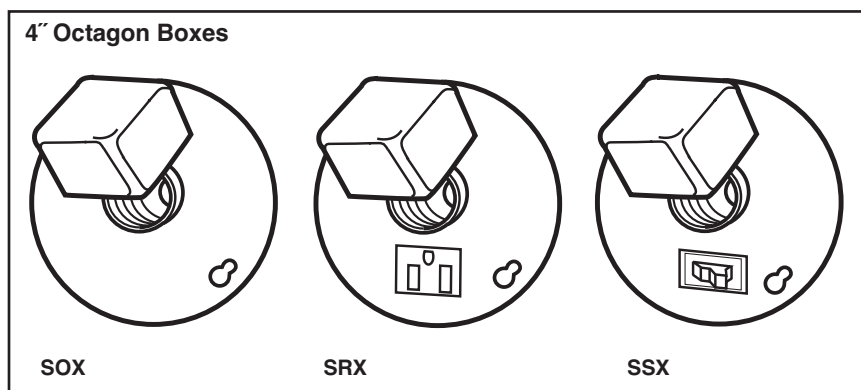
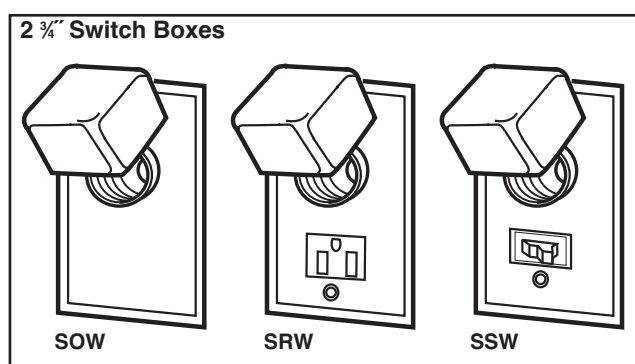
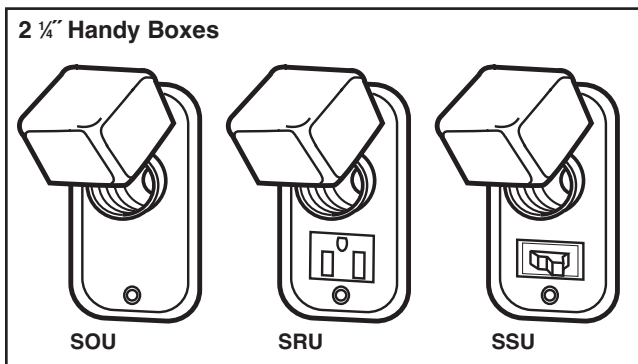

UL/CSA Fuses
Current Limiting

UL/CSA Fuses
General Purpose

Special
Purpose Fuses

Canadian
Fuses & Holders

Medium
Voltage Fuses

Fuse Blocks,
Holders & Misc.

Application
Section



Features and Benefits

- High Short-Circuit Current Ratings (SCCR) up to 200kA
- Suitable for installation in wireways and industrial control panel feeder and branch circuits
- Small footprint saves panel space
- Enclosed for enhanced safety

Agency and Standards

- UL Listed 1953, Guide QPQS, File E256146
- CSA Certified, Class 6228-01, File 700490
- CE
- IEC 60947-7-1; IEC 60539

Electrical:

- Short-Circuit Current Ratings up to 200kA, see table next page
- Ampacities up to 760 amps
- 600Vac/dc (UL 1953), 690Vac/dc (IEC)
- 75°C Rated connectors
- Cu Wire range 14AWG to 500kcmil (2.5 to 240mm²)

Mechanical:

- DIN rail or panel mount (EPDB306 & EPDB702 panel mount only)
- Sliding DIN rail latch for easy mounting
- Captive termination screws, so screws do not get misplaced
- Screws backed out at the factory to save conductor installation time
- Single-pole, gang mountable for multiple pole applications
- Flammability, UL 94V0
- Tin-plated Al connectors suitable for Cu conductors
- Elongated hole for panel mounting - easier mounting with greater flexibility in matching up with drilled panel holes
- DIN rail end anchors required to prevent damage to block when torquing, anchors available from third-party supplier

Electrical Data

UL/CSA Fuses
Current Limiting

UL/CSA Fuses
General Purpose

Special
Purpose Fuses

Canadian
Fuses & Holders

Medium
Voltage Fuses

Fuse Blocks,
Holders & Misc.

Application
Section

Series EPDB

Electrical		Terminal Copper Conductor Capability				Short-Circuit Current Rating Data							
Part Number	Amps	Lineside	Loadside	Configuration		Conductors		Max Fuse Class & Amp**				SCCR	
		Wire Range	Wire Range	Line	Load	Line	Load	J	T	RK1	RK5		
						AWG or kcmil	AWG or kcmil	JDL	TJS TJN	LESRK LENRK	ECSR ECNR		
EPDB101	175A	2/0 to 8 AWG 70 to 10mm ²	2/0 to 8 AWG 70 to 10mm ²			2/0 to 8	2/0 to 8	200	200	100	60	200 kA	
EPDB104	175A	2/0 to 8 AWG 70 to 10mm ²	4 to 14 AWG 25 to 2.5mm ²			2/0 to 8	4 to 12	200	200	100	60	200 kA	
							14	175	175	100	60	100 kA	
								200	200	100	60	50 kA	
EPDB301	310A	350kcmil to 6 AWG 185 to 16mm ²	350kcmil to 6 AWG 185 to 16mm ²			350 to 6	350 to 6	400	400	200	100	200 kA	
EPDB306	380A	500kcmil to 6 AWG 240 to 16mm ²	2 to 14 AWG 35 to 2.5mm ²			500 to 6	2 to 6	400	400	200	100	200 kA	
							8 to 14	200	200	100	30	50 kA	
								175	175	100	30	100 kA	
EPDB512	570A	300kcmil to 4 AWG 150 to 25mm ²	4 to 14 AWG 25 to 2.5mm ²			300	4 to 8	600	600	400	200	200 kA	
							250 to 4	4	600	600	400	200	50 kA
								6 to 14	200	200	100	30	50 kA
EPDB602	620A	350kcmil to 4 AWG 185 to 25mm ²	350kcmil to 4 AWG 185 to 12mm ²			300 to 4	350	350	600	600	400	200	200 kA
							300 to 4	300 to 4	600	800*	600	200	100 kA
EPDB702	760A	500kcmil to 6 AWG 240 to 16mm ²	500kcmil to 6 AWG 240 to 16mm ²			500	500	500	600	800*	600	400	200 kA
							400 to 6	600	800*	600	600	100 kA	
								400 to 6	400 to 6	600	600	400	200

Ampacities 75°C per NEC[®] Table 310.16 and UL 508A Table 28.1

*Class L 800A (LCL 800) or less fuses suitable for this particular SCCR case.

**Class G 60A (SEC-60) or less or Class CC 30A (EDCC30, HCTR30, HCLR30) or less are suitable for all the SCCRs in this table.

Series EPDB

Part Number	Lineside				Loadside				Wire Connector Hole Diameter		Min. Enclosure Size - inch	
	CU Wire Range	Torque Lb-In (N m)	Trim Length in (mm)	Hex Key	CU Wire Range	Torque Lb-In (N m)	Trim Length in (mm)	Hex Key	Lineside in (mm)	Loadside in (mm)		
EPDB101	2/0 to 8 AWG 70 to 10mm ²	110 (12.4)	0.85 (21.6)	3/16"	2/0 to 8 AWG 70 to 10mm ²	110 (12.4)	0.97 (24.6)	3/16"	0.45 (11.5)	0.45 (11.5)	16 X 16 X 6.75	
EPDB104	2/0 to 8 AWG 70 to 10mm ²	120 (13.6)	0.75 (19.0)	3/16"	4 to 6 AWG 25 to 16mm ²	35 (4.0)	0.55 (14) top row 0.85 (21.6) bottom row	1/8"	0.45 (11.5)	0.246 (6.25)	16 X 16 X 6.75	
					8 AWG 10mm ²							25 (2.8)
					10 to 14 AWG 6 to 2.5mm ²							20 (2.3)
EPDB301	350 Kcmil to 6 AWG 185 to 16mm ²	275 (31.1)	1.35 (34.3)	5/16"	350 Kcmil to 6 AWG 150 to 16mm ²	275 (31.1)	1.25 (31.8)	5/16"	0.72 (18.3)	0.72 (18.3)	36 X 30 X 12.625	
EPDB306	500 Kcmil to 6 AWG 240 to 16mm ²	500 (56.5)	1.25 (31.8)	3/8"	2 to 3 AWG 35mm ²	50 (5.7)	0.59 (15) top row 1.2 (30.5) bottom row	1/8"	0.87 (22.1)	0.314 (8.0)	24 X 20 X 6.75	
					4 to 6 AWG 25 to 16mm ²							45 (5.1)
					8 AWG 10mm ²							40 (4.5)
					10 to 14 AWG 6 to 2.5mm ²							35 (4.0)
EPDB512	300 Kcmil to 4 AWG 150 to 25mm ²	275 (31.1)	1.15 (29.2) top row 1.4 (35.6) bottom row	1/4"	4 to 6 AWG 25 to 16mm ²	35 (4.0)	0.55 (14) top row 1 (25.4) middle row 1.22 (31) bottom row	1/8"	0.687 (17.5)	0.265 (6.7)	24 X 20 X 6.75	
					8 AWG 10mm ²							25 (2.8)
					10 to 14 AWG 6 to 2.5mm ²							20 (2.3)
EPDB602	350 Kcmil to 4 AWG 185 to 25mm ²	275 (31.1)	1.250 (31.8)	5/16"	350 Kcmil to 4 AWG 185 to 25mm ²	275 (31.1)	1.25 (31.8)	5/16"	0.718 (18.2)	0.718 (18.2)	36 X 30 X 12.625	
EPDB702	500 Kcmil to 6 AWG 240 to 16mm ²	500 (56.5)	1.25 (31.8)	3/8"	500 Kcmil to 6 AWG 240 to 16mm ²	500 (56.5)	1.25 (31.8)	3/8"	0.875 (22.2)	0.875 (22.2)	36 X 30 X 12.625	

Dimensions – in (mm)

Part Number	Width	Length	Height	D	E	F	G	H
	A	B	C					
EPDB101	1.03 (26.16)	3.372 (94.8)	2.15 (54.5)	3.55 (90.17)	2.91 (73.79)	0.2 (5)	0.2 (5)	N/A
EPDB104	1.03 (26.16)	3.372 (94.8)	2.15 (54.5)	3.55 (90.17)	2.91 (73.79)	0.2 (5)	0.2 (5)	N/A
EPDB301	1.55 (39.37)	4.67 (118.5)	2.874 (73)	4.48 (113.67)	3.81 (96.77)	0.2 (5)	0.24 (6)	N/A
EPDB306	1.55 (39.37)	4.67 (118.5)	2.95 (74.93)	4.48 (113.67)	3.81 (96.77)	0.2 (5)	0.24 (6)	N/A
EPDB512	1.88 (47.62)	4.67 (118.5)	2.93 (74.5)	4.48 (113.67)	3.81 (96.77)	0.2 (5)	0.24 (6)	N/A
EPDB602	2.38 (60.45)	4.67 (118.5)	2.60 (66)	4.48 (113.67)	3.81 (96.77)	0.2 (5)	0.24 (6)	N/A
EPDB702	2.56 (65.02)	4.67 (118.5)	3.15 (80)	4.48 (113.67)	3.81 (96.77)	0.2 (5)	0.24 (6)	1.81 (46)

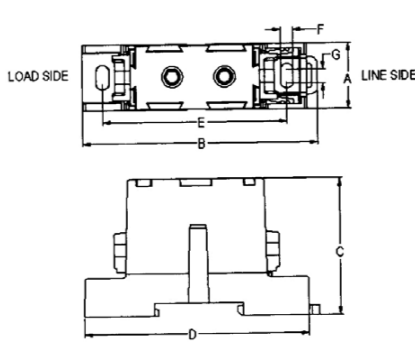

EPDB101

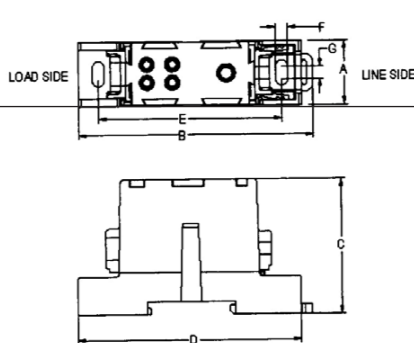

EPDB104

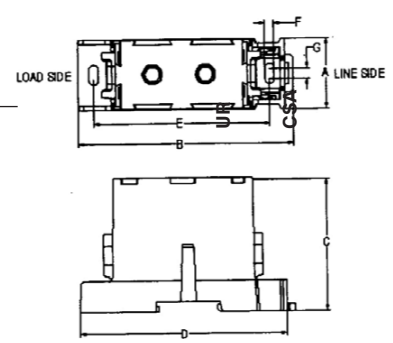

EPDB301

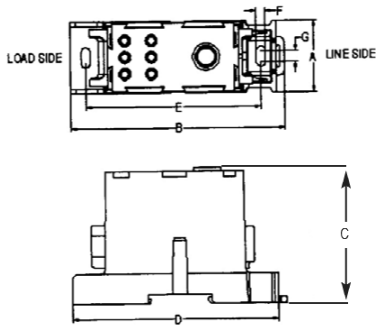

EPDB306

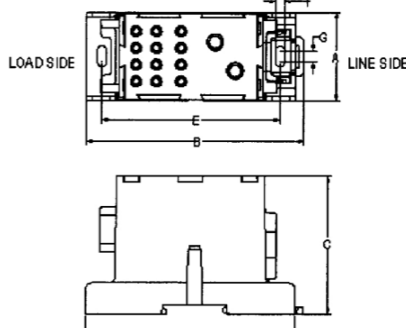

EPDB512

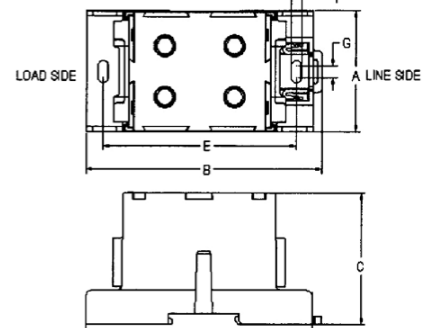

EPDB602

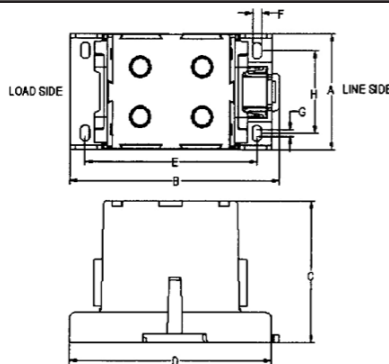

EPDB702



Electrical:

- Short-circuit current ratings up to 200kA, see table next page
- Ampacities up to 310A
- 600Vac/dc (UL 1953)
- 75°C rated connectors
- Cu Wire range 14AWG to 350kcmil

Mechanical:

- Flammability, UL 94V0
- Panel mount
- Tin-plated aluminum (Al) connectors suitable for copper (Cu) conductors

Agency and Standards

- UL 1059 Recognized, Guide XCFR2, File E221592
- General Industry Class per UL 1059, usage Category C
- CSA Certified, Class 6228-01, File 700489

Features and Benefits

- High short-circuit current ratings up to 200kA
- UL 1059 Recognition
- 1-, 2- and 3-poles

Dimensions (inches)

PB1011-10S3 Series (1-, 2-, and 3-pole)

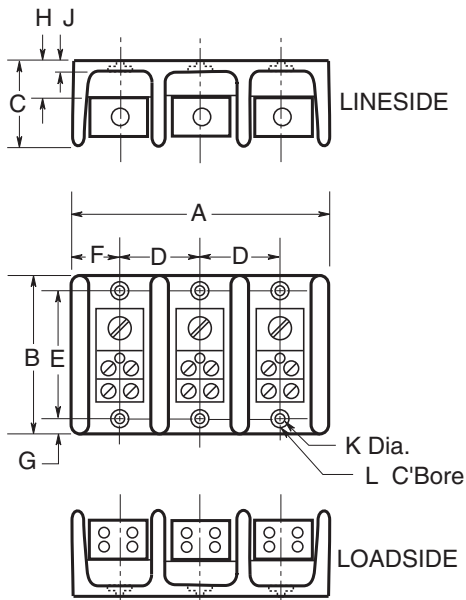

PB1061-3093 Series (1-, 2-, and 3-pole)

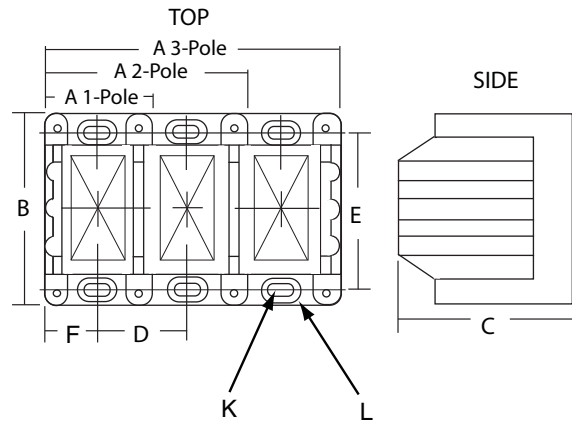

Part Number	Width/Poles			Length B	Height		D	E	F	G	H	J	K	L
	A/1	A/2	A/3		C									
PB1011-10S3	1.06	1.88	2.60	2.88	1.75	0.81	2.25	0.53	0.31	0.84	0.31	-	0.20	0.42
PB1061-3093	1.96	3.58	5.20	4.00	3.32	1.62	3.37	0.97	-	-	-	-	Slot 0.20x0.41	Slot 0.42x0.62

Electrical Data

Part Number	Amps	Number of Poles	Terminal Copper Conductor Capability			Short-Circuit Current Rating Data							Minimum Enclosure Size Inches
			Wireside	Loadside	Configuration	Conductors		Max Fuse Class & Amp*				SCCR kA	
						Line	Load	J	T	RK1	RK5		
PB1011	175A	1	2/0 TO 8 AWG	2/0 TO 8 AWG		2/0 to 8	2/0 to 8	200	200	200	60	200	16 X 16 X 6.75
PB1012		2											
PB1013		3											
PB1041	175A	1	2/0 TO 8 AWG	4 TO 14 AWG		2/0 to 8	4 to 12	200	200	200	60	200	16 X 16 X 6.75
PB1042		2					175	175	100	60	100		
PB1043		3					200	200	100	60	50		
PB10S1	175A	1	2/0 TO 8 AWG	1/4-20 X 3/4 STUD		2/0 to 8	Stud	200	200	100	60	200	16 X 16 X 6.75
PB10S2		2											
PB10S3		3											
PB1061	175A	1	2/0 TO 8 AWG	4 TO 14 AWG		2/0 to 8	4 to 12	400	400	200	100	200	24 X 20 X 6.75
PB1062		2					400	400	400	100	100		
PB1063		3					175	175	100	60	100		
PB3061	310A	1	350 kcmil to 4 AWG	4 TO 12 AWG		350 to 4	4 to 8	400	400	200	100	200	24 X 20 X 6.75
PB3062		2					400	400	400	100	100		
PB3063		3					175	175	100	60	100		
PB3121	310A	1	350 kcmil to 4 AWG	4 TO 14 AWG		350 to 4	4 to 8	400	400	200	100	200	24 X 20 X 6.75
PB3122		2					400	400	400	100	100		
PB3123		3					175	175	100	60	100		
PB3091	310A	1	350 kcmil to 4 AWG	(6) 2 to 12 AWG (3) 1/0 to 12		350 to 4	1/0 to 6	400	400	200	100	200	24 X 20 X 6.75
PB3092		2					400	400	400	100	100		
PB3093		3					175	175	100	60	100		

Ampacities 75C per NEC® Table 310.16 and UL508A Table 28.1

*Class G 60A (SEC-60) or less or Class CC 30A (EDCC30, HCTR30, HCLR30) or less are suitable for all the SCCR in this table

Optional Covers & Dimensions (inches)

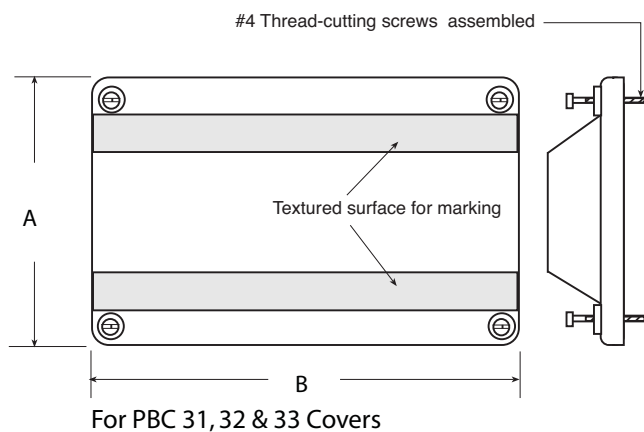

Block	Poles	Cover Part Number	A (In)
PB1011, 1041, 10S1	1	PBC21	0.94
PB1012, 1042, 10S2	2	PBC22	1.75
PB1013, 1043, 10S3	3	PBC23	2.56
PB1061, 3061, 3091, 3121	1	PBC31	2.10
PB1062, 3062, 3092, 3122	2	PBC32	3.72
PB1063, 3063, 3093, 3123	3	PBC33	5.34

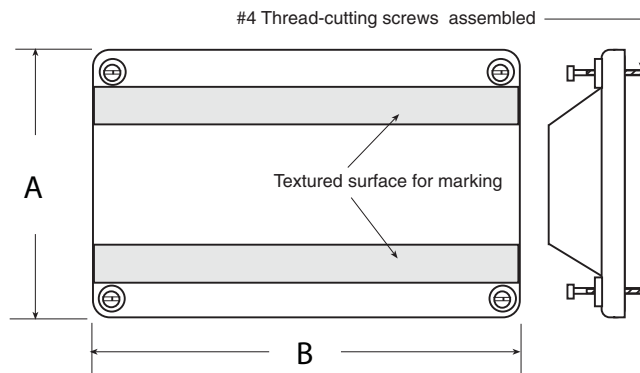
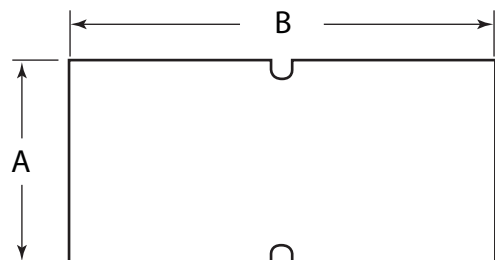



Feature and Benefits

- Available in 1-, 2-, or 3-pole versions
- Thermoset material to withstand high heat applications
- Optional cover is clear with write-on surface for field termination identification (Order PBC Series)
- For industrial controls, HVAC and other control automation panel applications
- Mounting slots allow greater flexibility to fit pre-drilled panel holes

Voltage Ratings:

- 600Vac/dc maximum
- 75°C Rated connectors

Mechanical:

- Panel mount
- Tin-plated aluminum connectors
- Flammability: UL 94V0

Agency Information:

- UL Recognized, Guide XCFR2, File E221592, General Industrial Class per UL 1059
- CSA Certified: CSA File 700489, Class 6228-01

Dimensions (inches)

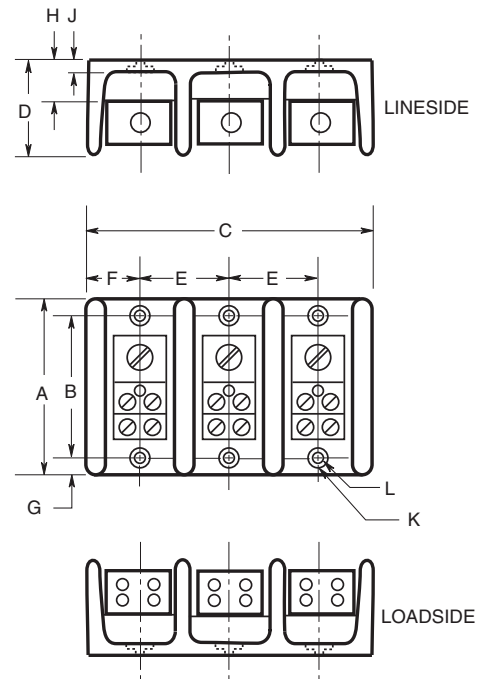

Series	A	B	C1	C2	C3	D	E	F	G	H	J	K (Slot)	L (Slot)
PB401X, PB512X	4.00	3.38	1.98	3.6	5.21	3.32	1.62	0.99	0.31	0.87	0.35	0.20" wide x 0.41" long	0.42" wide x 0.62" long
PB712X	5.5	4.75	3.1	5.79	8.48	2.93	2.69	1.55	0.38	1.19	0.44	0.20" wide x 0.33" long	0.41" wide x 0.53" long

Electrical Data

Part Number	Number Poles	Connection				Connector Material & Ampacity
		Lineside		Loadside		
		Wire Range per pole	Torque (Lb-In)	Wire Range per pole	Torque	
PB4011	1	(1) 500kcmil - #6 Cu-Al	500	(1) 3/8 - 16 x 1 Stud	-----	AL-380A
PB4012	2					
PB4013	3					
PB5121	1	(2) 300kcmil - #4 Cu-Al	275	(12) #4 - #14 Cu, #4 - #12 Al	20	AL-570A
PB5122	2					
PB5123	3					
PB7121	1	(2) 500kcmil - #6 Cu-Al	500	(12) #4 - #14 Cu-Al	35	AL-760A
PB7122	2					
PB7123	3					

Optional Covers & Dimensions (inches)

PB4 & PB5

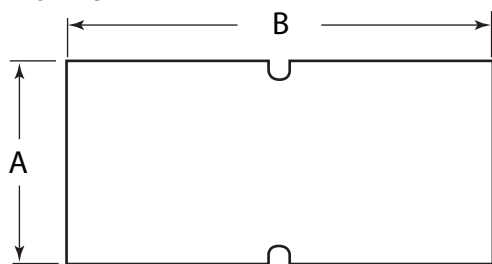

Series	Poles	Cover Part Number	A	B
PB4 & PB5	1	PBC31	4.14	2.10
	2	PBC32	4.14	3.72
	3	PBC33	4.14	5.34
PB7	1	PBC71	3.00	2.75
	3	3 (PBC71)		

PB7

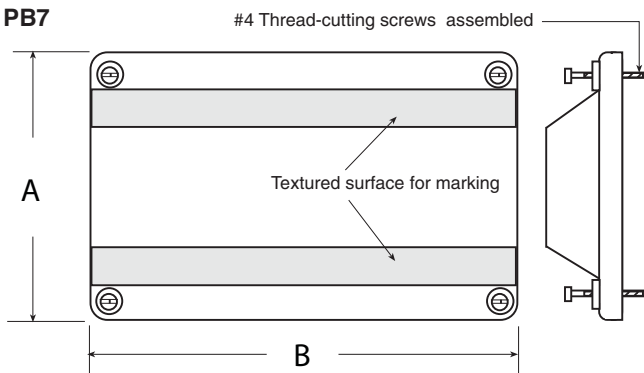

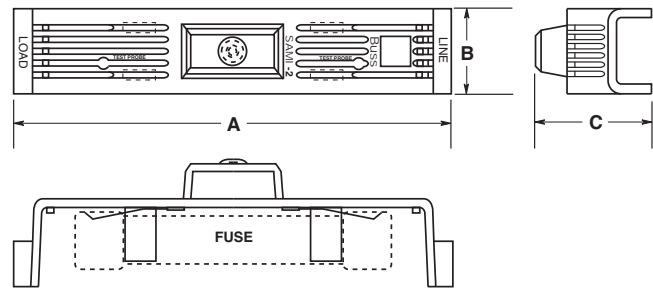

Catalog Number SAMI™ Series

Indicating Fuse Covers:

SAMI™ Series: For Class J, RK1, RK5, H, K5, CC, G and midget type fuses.

Operating Voltage:

Non-Indicating - 0-600Vac/dc
Indicating - 90 to 600Vac
- 115 to 600Vdc

Amp Rating: 0 - 100A

Agency Approvals: UL Listed
CSA (Class 6225-01,
File No. LR47235)

Material: Black Thermoplastic with a flammability rating of UL 94V2

Catalog Data (600V) Dimensional Data (inches)

Catalog Number*	Description	A	B	C
SAMI-1	600V, J (0-30A) and 250V, RK, K5, H (35-60A)	5.02	1.03	1.94
SAMI-2	600V, RK, K5, H (0-30A)	7.03	1.30	2.07
SAMI-3	600V, J (65-100A)	7.03	1.30	2.33
SAMI-4	250V, RK, K5, H (65-100A)	8.20	1.30	2.18
SAMI-5	600V, RK, K5, H (35-60A)	8.20	1.30	2.18
SAMI-6	600V, J (35-60A)	4.98	1.17	2.14
SAMI-7**	600V, Midget	3.82	0.75	1.72
SAMI-8†	600V, RK, K5, H (65-100A)	10.38	1.50	2.33
SAMI-9	250V, RK, K5, H (0-30A)	3.82	0.75	1.72

*Catalog Numbers

For Indicating Cover, add suffix **I**.
For Non-indicating cover, add suffix **N**.
Example: SAMI-7I = Indicating
SAMI-7N = Non-indicating

Indicating feature requires a minimum of 90Vac or 115Vdc to illuminate lamp.

**UL Recognized

† **SAMI-8A** adapter available for small RK, K5, H body design. **SAMI-8N** comes standard with adapter (**SAMI-8A**)

SAMI Features:

- Innovative design, covers exposed terminals and contacts of Edison fuse blocks.
- Fits most competitive fuse blocks.
- Light on indicating SAMI shows when the fuse is open—helps troubleshoot the system and reduces downtime.
- All versions are reusable—no need to pay for indication every time a fuse opens.
- Indication contacts have teeth to break oxidation layer on the existing fuse endcap to provide a clear signal path.
- Less than 0.6mA leakage current at 600 volt.
- Visual marking of lineside and loadside.
- SAMI cover ends can easily be trimmed if necessary, to fit cover over existing wiring or to fit most safety switches.
- Dead front construction provides added protection against accidental contact by maintenance personnel.
- Labels are provided with the SAMI fuse cover for writing in circuit or fuse information.
- One cover is required for each pole.

WARNING: To avoid electrical shock, turn power off before installing, removing or servicing.

For SAMI trimming guide specifications refer to the following data sheet numbers:
7008 - SAMI 1-9 Trimming Guides.

UL/CSA Fuses
 Current Limiting

UL/CSA Fuses
 General Purpose

Special
 Purpose Fuses

Canadian
 Fuses & Holders

Medium
 Voltage Fuses

Fuse Blocks,
 Holders & Misc.

Application
 Section

Single-Pole

$\frac{13}{32}$ " x 1 $\frac{1}{2}$ " Fuses



HEB-

For any $\frac{13}{32}$ " x 1 $\frac{1}{2}$ " fuse. Fuse holder rated 30A, 600V (CSA Listed 15A max.). Typical fuse types: Edison MOL MEN, MEQ and MCL. ($\frac{1}{10}$ -30A)



HET-

A HEB- fuse holder with a permanently installed solid neutral. Easily identified by white plastic coupling nut.

Double-Pole

Class CC

$\frac{13}{32}$ " x 1 $\frac{1}{2}$ " Midget Fuses



HEY-

Double-pole fuse holder has water-resistant, polarized design, and accepts Class CC branch circuit fuses (Edison fuse types EDCC, HCTR or HCLR, 600V or less) Particularly applicable in street lighting circuits with optional breakaway receptacle.



HEX-

For any $\frac{13}{32}$ " x 1 $\frac{1}{2}$ " fuse. Fuse holder rated 30A, 600V (CSA Listed 15A max.). Typical fuse types: Edison MOL MEN, MEQ and MCL. ($\frac{1}{10}$ -30A)

Single- and Double-Pole without Breakaway Option

Packaging & Ordering Information:

XXX	—		
HEB HET HEY HEX		Load Side Terminal A thru W	Line Terminal A thru W

Single-Pole with Breakaway Option

Packaging & Ordering Information:

XXX	—		W	—	
HEB or HET		Load Terminal A thru K	Line Terminal		Break-W-Way Terminal RLC - A thru J or RYC

Double-Pole with Breakaway Option

Packaging & Ordering Information:

XXX	—		W	—	
HEX or HEY		Load Terminal A thru K	Line Terminal		Break-W-Way Terminal DRLC - A thru J or DRYC

Available Part Numbers

Non-Breakaway Units:

HEB-AA^{(1) (2) (3)}, HEB-AB⁽²⁾, HEB-AC⁽²⁾,
 HEB-AD⁽²⁾, HEB-AE⁽²⁾, HEB-AJ, HEB-AK, HEB-AL, HEB-AR,
 HEB-AY, HEB-BA⁽²⁾, HEB-BB⁽²⁾, HEB-BC⁽²⁾, HEB-BD⁽²⁾,
 HEB-CC⁽²⁾, HEB-DD⁽²⁾, HEB-JJ, HEB-JK, HEB-JL, HEB-JY,
 HEB-LL, HEB-NN, HEB-PP⁽²⁾, HEB-QQ⁽²⁾, HEB-RR⁽²⁾,
 HEB-SS, HEB-TT⁽²⁾, HEB-ZA.

Agency Information:

⁽¹⁾UL Recognized, Guide IZLT2, File E14853
⁽²⁾CSA Certified, Class 6225-01, File 47235
⁽³⁾CE

Breakaway Units:

(Includes fuse holder, breakaway part and insulating boots):
 HEB-AW-RLA, HEB-AW-RLC-A^{(1) (2) (3)}, HEB-AW-RLC-B,
 HEB-AW-RLC-C, HEB-AW-RLC-J, HEB-AW-RYA,
 HEB-AW-RYC, HEB-BW-RLC-A, HEB-BW-RLC-B,
 HEB-BW-RYC, HEB-JW-RLC-J, HEB-JW-RYC,
 HEB-KW-RLC-J, HEB-KW-RYC, HEB-LW-RLA,
 HEB-LW-RLC-J, HEB-LW-RYA









Agency Information:

⁽¹⁾UL Recognized, Guide IZLT2, File E14853
⁽²⁾CSA Certified, Class 6225-01, File 47235
⁽³⁾CE

Catalog and Specification Data

Note: The construction elements listed below illustrate the full construction of the available part numbers. NOT all construction elements are available in all combinations.

Conductor Terminals

Type Terminal	Conductor Data				Terminal Symbols			
	Size	No. Per Terminal	Solid	Stranded	Load Side	Line Side		
Copper Crimp 		#12 to #8	1	•	•	A	A	
		#12	2	•	•			
		#10	2	•	•			
		#6	1	•	•	B	B	
		#4	1	•	•			
	Copper Set-Screw 		#8	2	•	•	C	C
			#4	1	—	•		
			#6	2	•	•	D	D
			#2	1	—	•		
			#4	2	•	•	E	E
Copper Set-Screw 		#12 to #2	1	•	•	J	J	
		#12 to #2	2	•	•	K	K	
Solid Breakaway 	(Required with Breakaway Receptacle) 					W	W	

Available Part Numbers

HEX Series:

HEX-AA⁽¹⁾ (2), HEX-AB, HEX-AC, HEX-AD, HEX-AE, HEX-AY, HEX-BB, HEX-CC, HEX-JJ, HEX-JK, and HEX-KK.

Agency Information:

⁽¹⁾UL Recognized, Guide IZLT2, File E14853

⁽²⁾CSA Certified, Class 6225-01, File 47235



HEY Series:

HEY-AA, HEY-AB, HEY-AC, HEY-AD, HEY-AE, HEY-AL, HEY-BB, and HEY-JJ.

HET Series:

HET-AA, HET-AB, HET-BB, HET-JJ, and HET-JK

Optional

Type Terminal	Conductor Data				Breakaway Terminal	
	Size	No. Per Terminal	Solid	Stranded	Single-Pole	*Double-Pole
Copper Crimp 	#12 to #8	1	•	•	-RLC-A	-DRLC-A
	#6	1	•	•	-RLC-B	-DRLC-B
	#4	1	•	•	-RLC-C	-DRLC-C
Copper Set-Screw 	#12 to #2	1	•	•	-RLC-J	-DRLC-J
					#12 to #2	2

* Terminal illustrations show the end view of single-pole receptacles and one-pole only of the double-pole receptacles. Thus, for example, in the case of a double-pole, set-screw type receptacle with terminals that accept two conductors, a total of four conductors could be connected to the receptacle per the following drawing.



Catalog Data — Insulating Boots

Catalog Numbers	Type
2A0660	Single Conductor
2A0661	Two Conductor

Insulating boots are optional and not included with non-Breakaway holders and must be ordered separately. They are included as a standard item with the breakaway series.

When boots are utilized, extra heat retention requires that fuses are sized at a minimum of 200% of the RMS load current.

Watertight Fuse Protection



HEB in-line fuse holders are water resistant and easy to install. Protect fuses in locations exposed to water, weather, corrosive fumes, salt-spray, etc. Holders are two-sectioned, molded plastic. The captive nut couples the loadside section to the lineside section; compression of the o-ring when the nut is tightened forms a vapor and water resistant unit.

Double-Pole Fuse Holders For Simultaneous Non- Load-Break Disconnect of Two Conductors



HEX and HEY units permit the fusing of two conductors. Loadside conductors can be disconnected from the lineside conductors by disengaging a captive stainless steel screw. Positive non-load-break disconnect (for non-energized circuits) provides maintenance safety. Helps prevent shock. Makes loads electrically dead.

Fuse holders are polarized. They can be used for line-to-line or line-to-neutral loads. Polarization prevents inadvertent reversal of loadside conductors (provides compliance with NEC® Section 240-22).

Both loadside terminals are always identical; both lineside terminals are always identical.

Serve As A Non-Load-Break Disconnect



The body of the fuse recesses within the loadside section so that it does not make electrical contact with the lineside section until the coupling nut engages the threads on the lineside section. The holder section thus provides a positive means of breaking or opening a non-energized electrical circuit for maintenance and repair.

Breakaway Receptacles For Impact Separation



Are available as an option with fuse holders. Ideally suited for breakaway lighting standards as required by state and federal highway commissions). Receptacle consists of a female terminal jacketed in an integral rubber insulating sleeve, and an external wire/cable terminal. The female terminal tightly mates with a lineside, solid, copper rod terminal (symbol "W") of the fuse holder. The insulating

sleeve also insulates the body of the lineside section of the fuse holder. Should the holder be subjected to an undue pull, it will separate from the lineside, Breakaway receptacle and become electrically dead. Separating the holder and receptacle on a non-energized circuit facilitates repair/maintenance.

Solid "W" Terminals Mate With Breakaway



Receptacles

A solid copper "rod" terminal must be used on the line-side of a fuse holder when holder is equipped with a breakaway receptacle. This solid rod terminal mates with the internal female terminal(s) of the breakaway receptacle. The letter "W" in the catalog number of the fuse holder designates this type terminal.



Crimp And Set-Screw Terminals

Crimp and setscrew type terminals are available for copper conductors.



Insulating Boots Save Installation Time

Boots come in two configurations - for single conductor and the "Y" type for two conductors. Fit all Edison in-line fuse holders. Designed to snugly fit over conductor insulation. Fits to wire by cutting off tapered tip. Diameter of conductor insulation cannot exceed 0.450". Inside of boots are treated with silicone to facilitate drawing of wire.

Boots come as a standard item with breakaway receptacles. They are optional and must be ordered separately for fuse holders without breakaway receptacles. **When boots are utilized, extra heat retention requires that fuses are sized at a minimum of 200% of the RMS load current.**

"Tap-Off" Connections

Fuse holders with terminal accepting two conductors can be used as a tap-off connector. Saves cost and manhours.



**Catalog Number HKP,
HKP-HH, and HKP-W**

Standard Fuse Holders:

For use with 1/4" x 1/4" fuses
(Edison type ABC, AGC, MDL, MDA
etc.)

Terminals: Bayonet-type knob.
Vibration resistant.
For panels up to 5/16"
(7.9mm) thick.

Agency Approvals:

UL Recognized, Guide IZLT2,
File E14853
CSA Certified, Class 6225-01,
File 47235

Electrical Ratings for HPF Series

Catalog Number	Amps	Volts	Fuse Description
HKP	30	250	—
HKP-HH	15	250	HKP with 1/4" Quick-connect terminal
HKP-W	30	250	HKP with drip-proof knob.

Dimensions - in (mm)

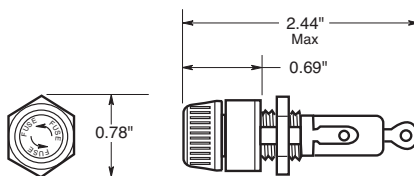

Punched Mounting Hole

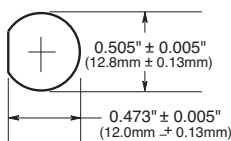

Catalog Number HPF

**Standard Fuse Holders With
Screw-Type Knob:**

For use with 1 1/2" x 1 5/16" to 1 1/2" fuses.

Agency Approvals:

UL Recognized, Guide IZLT8,
File E14853, cURus
UL 94V0 Flammability Rating

Electrical Ratings

Catalog Number	Amps	Volts	Fuse Description
HPF	30	600	1 1/2" (38.1mm) MOL, MEN, MCL
HPF-L	5	600	EBS, 13/32" x 1 3/8" fuses
HPF-EE	15	480	SEC 0-15, 13/32" x 1 3/8" fuses
HPF-JJ	20	480	SEC 20, 13/32" x 1 13/32" fuses
HPF-FF*	30	300	SEC 25 & 30, 13/32" x 1 5/8" fuses
HPF-RR	30	600	HCLR, HCTR & EDCC Class CC fuses
HPF-WT	30	600	Splash-proof knob for 1 1/2" fuses

*No CSA Certification.

Dimensions - in (mm)

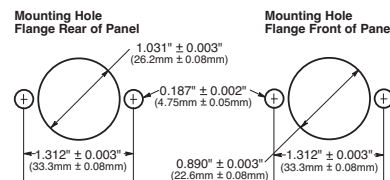
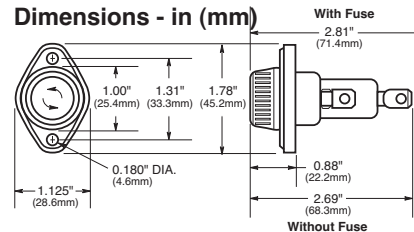

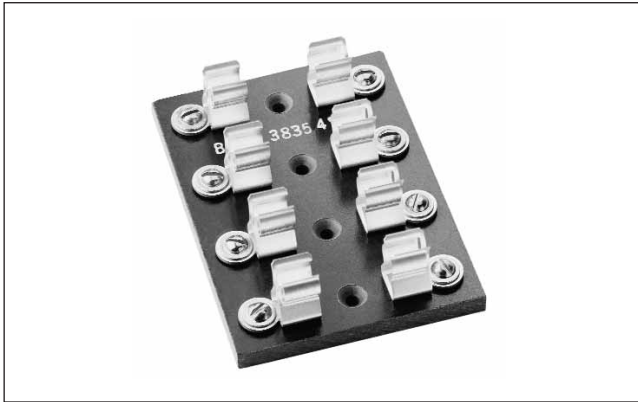

Catalog Number 3835 Series

Multiple Pole Fuse Blocks:
For 1/32" x 1 1/2" (10.3 x 28.1mm) fuses.

Amp Rating: 30A

Voltage Rating: 250Vac/dc

Material: Silver-plated, beryllium copper clips.
No side barriers. Screw terminals.
Phenolic base.

Catalog Data

Catalog Number	No. of Poles	Base Length - Inches (mm)
3835-1	1	27/32 (21.4)
3835-2	2	1-13/16 (46.0)
3835-3	3	2-25/32 (70.6)
3835-4	4	3-3/4 (95.2)
3835-5	5	4-23/32 (119.9)
3835-6	6	5-11/16 (144.5)
3835-7	7	6-21/32 (169.0)
3835-8	8	7-5/8 (193.7)
3835-9	9	8-19/32 (218.8)
3835-10	10	9-9/16 (242.9)
3835-12	12	11-1/2 (292.1)

*Base width — 2-3/4" (69.9mm)

Dimensions - inches (mm)

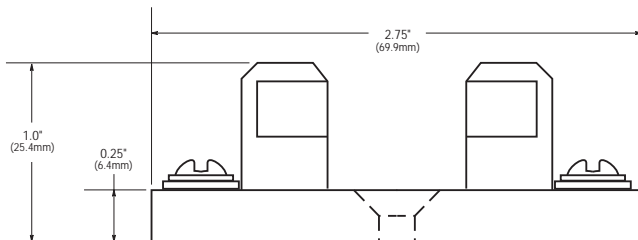

NOTE: Mounting screw hole diameter is 0.148" (3.7mm).
Countersink, 0.313" (7.9mm). Max. Mounting scrw No. 6.

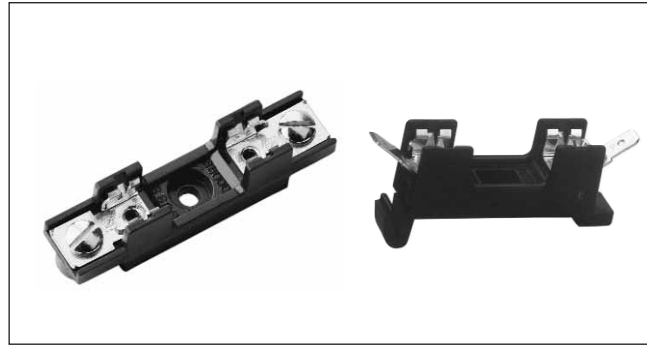

Catalog Number S-8000 Series

Bolt-in and Snap-in Mounting Fuse Blocks:

For 1/4" x 1 1/4" fuses.

Construction: Blocks are molded flame retarded thermoplastic. Clips are spring-bronze.

Voltage Rating: 300Vac/dc

Agency Approvals:

UL Recognized under Components Program; File E14853, Guide IZLT2

CSA Certified Class 6225-01, File 47235

Anti-Rotation Pin: Single-pole blocks may be ordered without the antirotational pin simply by adding an "X" to the number of poles (Example: BK/S-8001-1X).
10; shelf package: 100.

Carton Quantity:

Bulk Carton: Single-pole and 2-pole fuse blocks — 1,000; Multiple-pole fuse blocks — 3-8 pole: 200; 9-12 pole: 50.

When ordering bulk quantities, prefix "BK/" to catalog number: (Example: BK/S-8001-1SNP).

Bolt-in Mounting

Series	Terminal	Amps	Angle	*Basic Cat. No.	Poles (Suffix)
S-8000	Solder	UL 25A	0°	S-8001-	1 - 12
		CSA 21A	40°	S-8002-	
S-8100	3/16" Quick Connect	UL 20A	0°	S-8101-	
		CSA 16A	40°	S-8102-	
S-8200	1/4" Quick Connect	UL 20A	0°	S-8201-	
		CSA 16A	40°	S-8202-	
			Side	S-8203-	
S-8301	Screw	UL 30A CSA 10A	—	S-8301-	

Snap-in Mounting (Poles available in single-pole only)

Series	Terminal	Amps	Angle	Cat. No.
S-8000	Solder	UL 25A	0°	S-8001-1-SNP
		CSA 21A	40°	S-8002-1-SNP
S-8100	3/16" Quick Connect	UL 20A	0°	S-8101-1-SNP
		CSA 16A	40°	S-8102-1-SNP
S-8200	1/4" Quick Connect	UL 20A	0°	S-8201-1-SNP
		CSA 16A	Side	S-8203-1-SNP

Catalog Part Number System

Prefix for Bulk Packing	BK/						
S-8000 Series	S-8	0	00	-00	-SNP	-R	
Type Terminal							
Terminal Angle							
Number of Poles (01-12)							
RoHS							

* Available only in a single pole

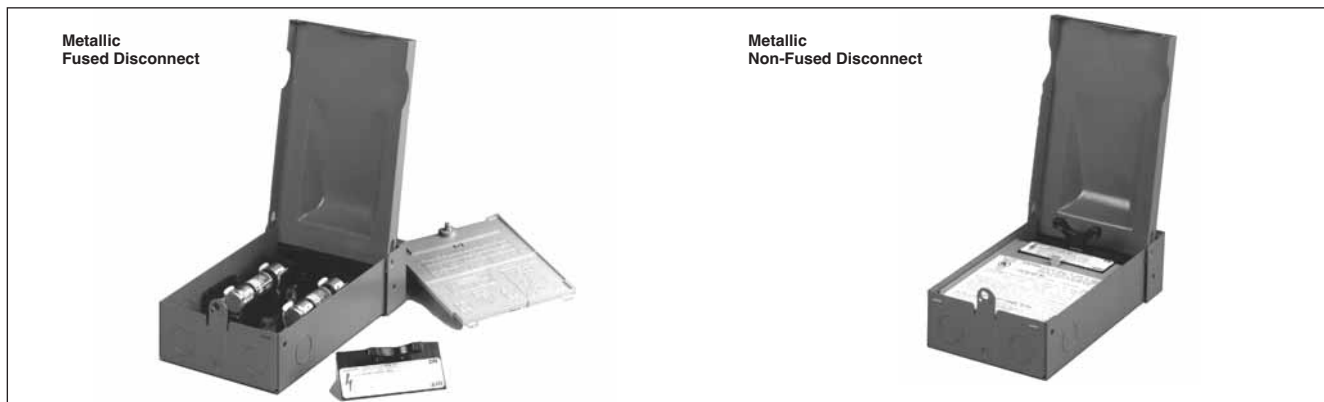

Catalog Number B22 Series

Rainproof Air Conditioner Pullout Units:
Fused, Non-Fused, GFCI and Cable Whip.

Agency Approvals: UL Listed to UL 1429
CSA Certification

Features:

- NEMA 3R enclosure.
- Compact design but offers ample working space.
- Internal shield can be removed without tools.
- Specifications are printed on internal shield.
- Knockouts on back, bottom and both sides.
- Finger-safe construction.
- Padlockable.

Metallic

Ratings: Single-Phase 2-Wire, 240Vac, 30 & 60A
UL Guide WGEW

Wire Range: #14-3 AWG, Al/Cu

Catalog Data

Main Rating	Catalog Number/Description	Maximum HP ¹		Approx. Dim. H x W x D (in.)
		120Vac	240Vac	
30A	B221-30F* Fused Disconnect (Class H or R)	1.5	3	8 3/4 x 5 3/8 x 3 1/2
30A	B221-30FGF Fused Disconnect with GFCI (Class H or R)	1.5	3	13 x 7 1/2 x 4 3/8
60A	B222-60F* Fused Disconnect (Class H or R)	3	10	8 3/4 x 5 3/8 x 3 1/2
60A	B222-60FGF Fused Disconnect with GFCI (Class H or R)	3	10	13 x 7 1/2 x 4 3/8
60A	B222-60NF Non-fused Disconnect	3	10	13 x 7 1/2 x 4 3/8
60A	B222-60NFGF Non-fused Disconnect with GFCI	3	10	11 3/4 x 6 1/2 x 4 1/2
60A	B222-60NFG12W** Non-fused Disconnect with 1/2 inch Cable Whip	3	10	14 3/4 x 12 1/2 x 4.5

*Suitable for use as service equipment with optional field installed lug kit number B-DPOG.

¹Rated with Edison ECNR and LENRK dual-element time-delay fuses.

** Maximum 30 amp upstream overcurrent protection device, 1/2 inch harness device, #10 ground hot wire size, #10 flexible wire size, six feet of conduit, 1-90° and 1- straight non-metallic fitting.



Features:

- Fuse reducers install on fuses and permit smaller size fuses to be used in larger amp size switches and blocks.
- Reducers will fit into any panel or switch including the dead-front type.
- Strong contact is maintained both mechanically and electrically.
- UL Listed.
- There are no reducers to go from 250V to 600V.
- There are no reducers for switching from one fuse class to another.
- There are no reducers for Class T or Class L fuses.

Fuses Reducers for Class H, J, K, & R Fuses

Agency Approvals: UL Listed,
Guide #IZZR, File #E12853
CSA Certified,
Class 6225-01, File 47235

Fuse Reducers for Class J Dimension Fuses- JDL, JFL, & CJ

Fuse Size	Desired Size	Catalog No. (Pairs)	
		Reducer No.	
30A	60A	**J-63	
30A	100A	**J-13	
60A	100A	**J-16	
60A	200A	**J-26	
100A	†200A	**J-21	
100A	†400A	**J-41	
200A	†400A	**J-42	
200A	600A	**J-62	
400A	†600A	**J-64	

† Not for Bolt-on Applications.

** Product does not have UL or CSA certification.

**Fuse Reducers for Class R Dimension Fuses
ECNR, LENRK, NCLR; ECSR, LESRK, & SCLR**

Fuse Size	Desired Size	Catalog No. (Pairs)	
		250V Reducer No.	600V Reducer No.
30A	60A	No. 263-R	No. 663-R
30A	100A	No. 213-R	No. 216-R
60A		No. 216-R	No. 616-R
60A	200A	No. 226-R	No. 626-R
100A		*No. 2621-R	
100A	400A	*No. 2641-R	
200A		*No. 242-R	*No. 642-R
100A		*No. 2661-R	
200A	600A	*No. 2662-R	
400A		**No. 2664-R	

* Product does not have CSA certification.

**Single reducer only (pair not required)

Note: Carton quantity - 10 pair.

**Fuse Reducers for Class H & K Dimension Fuses
KON, ERN, PONC, CDNC; KOS, ERS, CDSC**

Fuse Size	Desired Size	Catalog No. (Pairs)	
		250V Reducer No.	600V Reducer No.
30A	60A	No. 263	No. 663
30A	100A	No. 213	No. 216
60A	100A	No. 216	No. 616
60A	200A	No. 226	No. 626
100A	200A	No. 2621	No. 2621
100A	400A	*No. 2641	*No. 2641
200A	400A	No. 2642	No. 2642
100A	600A	*No. 2661	*No. 2661
200A	600A	*No. 2662	*No. 2662
400A	600A	*No. 2664	*No. 2664

* Product does not have CSA certification.

CROSS REFERENCE			
NEW EDISON	OLD EDISON	GOULD	LITTELFUSE
No. 263	38632	None	LRU263M
No. 213	38132	H1032	LRU213M
No. 216	38162	H1062	LRU216
No. 226	38262	None	None
No. 663	38636	None	LRU663M
No. 616	38166	H1066	LRU616
No. 626	38266	None	None
No. 2621	38212	None	LRU2621
No. 2641	2641E	None	None
No. 2642	38422	None	LRU2642
No. 2661	2661E	None	None
No. 2662	2662E	None	None
No. 2664	38642	None	None



Catalog Number SFC-FUSE-CAB
Spare Fuse Cabinet

Size: 24" wide x 30" high x 12" deep

FEATURES:

- Sturdy storage cabinet construction holds spare fuses.
- Cabinet door equipped with locking handle.
- Durable baked ASA 61 grey enamel.
- Mounting holes with key slot 16-inches on center.

Catalog Number SFC-SHELF
Extra shelf for spare fuse cabinet

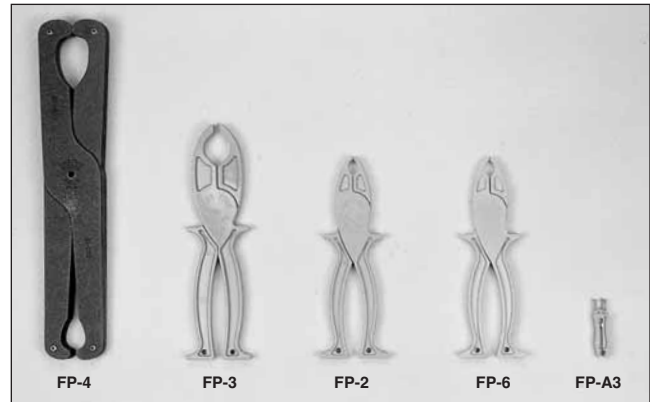

Fuse pullers

Catalog Data

Catalog Number	For Fuse Diameter	Carton Qty.	Fuse Type
FP-2	13/32" to 13/16"	10	0 – 60A, 250V 0 – 30A, 600V
FP-3	1" to 1 3/4"	10	70 – 200A, 250V 35 – 200A, 600V
FP-4	1 3/4" to 2 1/2"	1	225 – 600A, 250V 225 – 400A, 600V
FP-6	13/32" to 13/16"	1	Class T Fuses 0 – 60A, 300/600V
FP-A3	1/4" diameter and automotive blade fuses	10	Electronic glass and blade type

CROSS REFERENCE	
NEW EDISON	OLD EDISON
FP-2	38072
FP-3	38073
FP-4	38074



Fuse Clip-Clamps

Catalog Data

Clamp Size		Cat. No.	Ctn. Qty.	Weight	
Volts	Amps			Lbs.	Kg.
250	0-30A	No. 1	12	0.66	.30
	35-60A	No. 2	12	0.96	.44
600	0-30A	No. 2	12	0.96	.44
	35-60A	No. 4	12	1.44	.65
250 or 600	70-100A	No. 5	12	1.20	.54
	110-200A	No. 6	6	1.26	.57
	225-400A	No. 7	6	1.86	.84
	450-600A	No. 8	6	2.52	1.14

CROSS REFERENCE		
NEW EDISON	OLD EDISON	LITTELFUSE
No. 1	38001	LCC1
No. 2	38002	LCC2
No. 4	38004	LCC4
No. 5	38005	LCC5
No. 6	38006	LCC6
No. 7	38007	LCC7
No. 8	38008	LCC8

Low Voltage (600V or Less) Fuse Specification:

General:

The contractor shall install UL “Listed” fuses of the correct UL Class, type and ampere ratings in switches or place in spare fuses cabinet(s) as indicated on the plans and/or as specified below. All installed and spare fuses shall be in their original new, clean, dry and unused condition when installed and when placed in a spare fuses cabinet(s). The contractor shall thoroughly clean, mechanically check and electrically test, as required, all equipment and components before installing fuses and energizing.

UL Class L bolt-on fuses rated 601 to 6000A:

To mount UL Class L fuse types and amps ratings as shown on the plans, use stainless steel bolts of correct number, diameter and length, stainless steel spring washers on each side of the bolt and stainless steel nuts. The nuts shall be tightened to the torque recommended by ASTM Standards for the bolt size used. The bolts shall have the largest diameter that will fit the bolt holes and length to allow full nut thread engagement. Bolts shall be installed in each fuse mounting hole or slot. Class L fuses shall have silver links. The quality benchmark for Class L fuses shall be Edison Fusegear Catalog Symbol LCL time-delay type or Catalog Symbol LCU fast-acting type as shown on the plans. Edison Class L fuses are quality engineered and constructed, using Statistical Process Control, for foolproof filler retention without “O” rings, and do not expel gases.

UL Class R fuses rated up to 600A:

UL Class RK1 dual element, time-delay fuse type and ratings shall be installed in Class R switches as shown on the plans. Class RK1 dual element fuses shall not use springs in the overload elements in ratings 70A and larger; they shall have non-ferrous end caps for energy efficiency. The quality benchmark for Class RK1 dual element fuses shall be Edison Catalog Symbol LENRK(AMP)(250V) or LESRK(AMP) (600V).

UL Class J fuses rated up to 600A and 300V Class T fuses rated 35 to 800A:

Protection of circuit breakers requires the use of Class J or Class T fuses as shown on the plans. These fuse Classes are not interchangeable with fuses having less current limiting ability. The quality benchmark for these fuses shall be Edison Catalog Symbol JFL (Class J fast acting type) or Catalog Symbol TJN (300V Class T fast acting type).

Fuse classes, types and ratings:

All fuses have been specified as to UL Class, type, volts and amp rating on the plans when the project was engineered. No fuse types or ratings will be changed in the field without approval from the project design engineer. Generally, the fuse types commonly specified are Class L time-delay type, Class RK1 dual element type and Class J fast-acting type. Class L fast-acting, Class RK1 fast-acting and 300V Class T fast-acting fuses may be specified for special conditions.

Interchangeability of specified fuses:

The fuse brand specified is the quality benchmark and is preferred. All installed and spare fuses shall be both electrically and physically interchangeable with the same specific Classes, types and ratings of any other brand of fuses that are UL “Listed” per the appropriate UL Standard for safety without creating a safety hazard for the public and/or building occupants. Otherwise, a fuse-protected power distribution system design can not meet the requirements of good engineering practice, as applied during the design of this project, and can not meet the requirements of the National Electrical Code® during the life of the installation. The contractor shall place an instruction label inside the door of each switch (do not cover other instructions) identifying the UL Class, Type, Volts and Amp rating of originally installed fuses.

Spare fuses:

A metal spare fuse cabinet(s) shall be provided as required, surface mounted, with lockable handle. 10% of each type and rating of installed fuses shall be duplicated as spare fuses, or a minimum of 3 fuses of each type and rating, and placed in a Edison Catalog Symbol ESFC spare fuse cabinet(s) and locked.

Engineering plans and specifications:

A copy of the pertinent sheets of the plans and the pages of specifications pertaining specifically to installed fuses information shall be placed inside one of the Edison Catalog Symbol spare fuse cabinets for maintenance reference purposes.

Ambient Temperature*

The temperature of the air surrounding the fuse.

Arcing Time

The amount of time that passes from the instant the fuse element or link has melted until the overcurrent is interrupted or cleared.

Asymmetrical Current

Refer to ALTERNATING CURRENT. A-C current is asymmetrical when the loops about a zero axis are unequal (offset). This condition is usually associated with the first five or less cycles of fault current flow in a circuit that has inductive reactance. All power distribution systems have a variable amount of inductive reactance.

Body*

The part of the fuse which encloses the fuse elements and supports the contacts. Also referred to as cartridge, tube or case.

Bolted Fault

This refers to a zero impedance fault considered at locations in a power system where the maximum value of available fault current is calculated.

Bridge

The specially designed narrow portion of a fuse link that heats fastest under overcurrent conditions to open first.

Cartridge Fuse*

A fuse consisting of a current responsive element inside a fuse body with contacts on both ends.

Cartridge Size*

The range of voltage and ampere ratings assigned to a cartridge of specific dimensions and shape.

Clearing I²t (Ampere Squared Seconds)*

The measure of heat energy developed as a result of current flow between the time that current begins to flow and until the fuse clears the circuit. "I²" stands for the square of the effective let-through current and "t" stands for the time of current flow in seconds. The term I²t also applies during the melting or arcing portions of the clearing time and is referred to as melting or arcing I²t respectively. Clearing I²t is the sum of melting I²t and arcing I²t.

Clearing Time

This is the total opening time of a fuse from the occurrence of an overcurrent until the fuse stops current flow. This is the sum of link melting and arcing time.

Contacts*

The external metallic parts of the fuse used to complete the circuit. Also referred to as ferrules, caps, blades or terminals.

Current Limitation

A fuse provides current limitation when the link melts under short-circuit conditions to interrupt the current flow before the peak of the first one-half cycle of prospective current and the current flow is stopped within one-half cycle.

Current-Limiting Fuse*

A fuse that meets the following three conditions: 1) interrupts all available overcurrents within its interrupting rating; 2) within its current-limiting range, limits the clearing time at rated voltage to an interval equal to, or less than, the first major or symmetrical current loop duration; and 3) limits peak let-through current to a value less than the available peak current.

Current-Limiting Range*

A range of available currents from the threshold current to the interrupting current rating of a fuse.

Current Rating*

The A-C or D-C ampere rating which the fuse is capable of carrying continuously under specified conditions.

Delay

This refers to intentional "delay" designed into the overload range operation of a fuse and is meaningless except as defined by a fuse manufacturer. Other words used to indicate delay but not UL defined may be "Time-Lag", "Delay Type", etc..

Dual Element Fuse

The words "Dual Element" and "Time-Delay" appear on the labels of Class R fuses to indicate that the fuse has UL defined delay in the overload operation range of a minimum of 10 seconds at 500% of the fuse amperes rating. A "Dual Element" fuse has separate overload and short-circuit elements and is considered a "true time-delay fuse" design as opposed to other types of construction to obtain delay.

Effective Current (I_e)

"Effective" and "RMS" both refer to the heating effect value of an A-C current equivalent to a steady flow of a D-C current. "Effective let-through amperes" (I_e) refers to the heating effect value of the current allowed to flow during the clearing of a short-circuit current.

Eutectic Alloy

This is an alloy of lead, tin and other metals that, by metallurgical definition, changes from a solid directly to a liquid when its melting point is reached. This alloy is used in Edison Class R fuses for dependable overload element operation.

Fast-Acting Fuse

This is a fuse with no intentional time-delay designed into the overload range. Sometimes referred to as a "single element fuse" or "non-delay fuse".

Fault Current

Short-circuit current that flows partially or entirely outside the intended normal load current path of a circuit or component. Values may be from hundreds to many thousands of amperes.

Ferrule

The cylindrical brass, bronze or copper mounting terminals of fuses with amps ratings up to 60 amperes. The cylindrical terminals at each end of a fuse fit into fuse clips.

Filler*

A material used to fill a section or sections of a fuse which aids in arc extinction.

Fuse*

A protective device which opens by the melting of a current sensitive element during specified overcurrent conditions.

Heat Sink

A mass of metal, usually copper or a eutectic alloy, used in the overload element of Class R fuses to provide accurate time delay by absorbing heat from an overload current flow through a fuse.

High Rupturing Capacity (HRC)

HRC is used by Canadian and British Standards as an equivalent to the U.S. interrupting rating of a fuse. HRC must be at least 100,000 amperes.

*From ANSI/ NEMA FU1-86

I²t (Amperes Squared Seconds)

This is a value obtained by multiplying an effective current squared by the time of flow of the current in seconds. It is not a heat energy value, but represents heat energy for comparison purposes. Some common uses are to determine fuse selectivity and to select current limiting fuses that will limit this value to be compatible with the withstandability of semi-conductors that have an I²t rating.

Interrupting Rating*

A rating based upon the highest rms alternating current or direct current which the fuse is required to interrupt under specific conditions.

Knife Blade

A flat copper mounting blade (terminal) at each end of fuses rated 70 through 6000 amperes. Knife blades may be mounted in fuse clips or bolted in place via blade holes, depending on the fuse type.

Limiter

Limiters have internal construction like fuses but provide only short-circuit protection and no overload protection. They are intended for special applications such as Cable Limiters and Welder Limiters.

Link

The fusible portion of the fuse which melts, or reacts by other means, to clear the circuit during an overcurrent condition. Also referred to as an element.

Magnetic Stress

When thousands of amps of short-circuit current flows through equipment and conductors, strong magnetic fields are developed that may cause serious damage unless adequate physical bracing is applied. Force is proportional to the value of peak current squared. This force is usually reduced by current limiting fuses as compared to other overcurrent protective devices.

Maximum Energy*

A condition under which, in a specified time, the maximum amount of heat possible is generated in the fuse before clearing.

Melting Time*

The time from the initiation of an overcurrent to the instant arcing begins inside a fuse.

Nonrenewable Fuse*

A fuse which cannot be restored for service after operation.

Normal Frequency Recovery Voltage*

The normal frequency rms voltage impressed upon the fuse after the circuit has been interrupted and after high frequency transients have subsided.

One-Line Diagram

An electrical diagram that shows one line to represent two or more conductors for simplification.

One-Time Fuse

A term used to identify a non-renewable Class H fuse as opposed to a Class H fuse with replaceable links. See "non-renewable fuse".

Overcurrent*

Any current in excess of the fuse current rating.

Overload

A value of overcurrent usually considered to be up to about 10 times the ampere rating of an overcurrent protection device or circuit ampere rating.

Peak Arc Voltage*

The maximum peak voltage across the fuse during the arcing time.

Peak Let-Through Current (I_p)*

The maximum instantaneous current through a fuse during interruption in its current-limiting range.

Rating*

A designated limit of operating characteristics based on definite conditions.

Rejection Feature*

The physical characteristic of a fuse and fuseholder (slot, groove pin or overall dimension) which prevents substitution by other classes of fuses.

Renewable Fuse*

A fuse which can be readily restored for service after operation by the replacement of the renewal elements.

Renewal Element (Renewal Link)*

That part of a renewable fuse that is replaced after each interruption to restore the fuse to operating condition.

Short-Circuit Current

Refer to Fault Current.

Single-Element Fuse

Refer to Fast-Acting Fuse.

Supplemental Fuse (UL)

A UL fuse class per Standard 198G that defines certain small fuses not intended for branch circuit protection.

Thermal Stress

Heat builds up in equipment and conductors during the time of overcurrent flow that may cause thermal stress and potential thermal (heat) damage if overcurrent protection devices do not operate fast enough.

Threshold Current*

The minimum rms symmetrical available current of the current-limiting range, where melting of the fuse element occurs at approximately 90 degrees on the symmetrical current wave, and total clearing time is less than one-half cycle.

Threshold Ratio*

The threshold current divided by the fuse current rating.

Time-Delay Fuse*

A fuse capable of carrying a specific overcurrent for a minimum time.

Total Clearing Time*

Refer to Clearing Time.

Voltage Rating*

The maximum rms ac voltage or the maximum dc voltage at which the fuse is designed to operate.

*From ANSI/NEMA FU1-86

CROSS REFERENCE GUIDE

		VOLT	EDISON	BRUSH/ DORMAN	CEFCO	GEC/ GOULD	LITTELFSE.	FUSETEK	SIEMENS	NORAM	AEROFLEX	
UL CLASS CURRENT LIMITING FUSES (CSA CLASS)												
RK1 (HRCI-R)	Fast Acting	250 600	NCLR SCLR	NCLR SCLR	C-HG C-HR	A2KR, HNR A6KR, HSR	KLNR KLSR	RHN RHS	— —	— —	HB HA	
RK1 (HRCI-R)	Time Delay	250 600	LENRK LESRK	LENRK LESRK	LON-RK LOS-RK	A2D-R A6D-R	LLNRK LLSRK	— —	— —	2R-D 6R-D	— —	
RK5 (HRCI-R)	Time Delay	250 600	ECNR ECSR	ECNR ECSR	CRNR NRSR	TRNR, TR TRSR, TRS	FLN-R FLS-R IDSR	RDN RDS	— —	— —	— —	
L (HRCI-L)	Fast Acting	600	LCU	LCU	CL, CLU	A4BQ	—	LFA	—	6L-F	L8, L12	
L (HRCI-L)	Time Delay	600	LCL	LCL	CLL	A4BY, A4BT	KLPC, KLLU	—	—	6L-D	L16, L20	
J (HRCI-J)	Fast Acting	600	JFL	JCL, CJ	C-J	A4J, CJ	JLS	JFC	3NW2-71-	6J-F	JA	
J (HRCI-J)	Time Delay	600	JDL	—	—	AJT	JTD	—	—	J-D	—	
T (HRCI-T)	Fast Acting	300	TJN	TJN	—	A3T	JLLN	—	—	—	—	
T (HRCI-T)	Time Delay	600	TJS	TJS	—	A6T	JLLS	—	—	—	—	
G	Time Delay	480	SEC	—	—	AG5	SLC	—	—	—	—	
CC (HRCI-CC)	Time Delay	600	EDCC	—	—	ATDR	CCMR	—	—	6M-S	—	
CC (HRCI-CC)	Time Delay	600	HCTR	—	—	ATQR	KLDR	—	—	6CC-S	—	
CC (HRCI-CC)	Fast Acting	600	HCLR	HCLR	CTK-R	ATMR	KLKR	FLKR	—	6CC-F	—	
UL CLASS GENERAL PURPOSE FUSES												
H and K5	Fast Acting	250 600	KON KOS	KON KOS	50KOTN 50KOTS	OTN OTS	NLN NLS	OFN OFS	— —	— —	— —	
H Renewable	Time Lag	250 600	ERN ERS	ERN ERS	—	RFN RFS	RLN RLS	— —	— —	— —	— —	
H Renewable	Fuse Links	250 600	ELNE ELS	ELN ELS	—	RLN RLS	LKN LKS	— —	— —	— —	— —	
Midget	Fast Acting	600 600 250	MCL EBS MOL	MCL EBS MOL	CTK — —	ATM SBS OTM	KLK BLS BLF	FLK — FLF	— — —	6M-S 6N-F	— — —	
Midget	Time Delay	500 250 125/250	MEQ MEN MID	MEQ MEN MID	— — —	ATQ TRM GFN	FLO FLM FLA	FRM — —	— — —	— — —	— — —	
CANADIAN FUSES												
Code/ Standard	One Time	250 600	KON/PONC KOS	KON/PON KOS	50KOTN 50KOTS	NRN OTN NRS OTS	NLN NLS	OFN OFS	— —	— —	— —	
10K AIR	Time Delay	250 600	CDNC CDSC	CDN CDS	—	CRN CRS	FLN FLS	ODN ODS	— —	— —	— —	
TYPE K Class C	Offset Blade	600	CIH07 CIK07 CIL14	CIH07 CIK07 CIL14	C-K C-K C-K	ESK ESK ESK	— — —	— — —	— — —	— — —	— — —	
HRCI-CA	Fast Acting	600	CIF21	CIF21	C-N	MS	—	—	3NWOMFS2	6CA-F	—	
HRCI-CB	Fast Acting	600	CIF06 EK	CIF06/NK EK	CNS CES	GNS —	— —	NIC —	3NWOMFS1	6CB-F	— —	
HRC-II FUSES												
HRC-II-C	Offset Blade	600	H07C K07C L14C	H07C, AAO K07C, BAO L14C, CEO	CIA CIS CCP	FES, GIA FES, GIS FES, GCP	— — —	2C0 2C0 2C0	3NW2-11 3NW2-12 3NW2-13	6C-F 6C-F 6C-F	932 933 944	
HRC-II-C	Center Blade	600	M09C P11C R11C	M09C, DD P11C, EF R11C, FF	CF CM CLM	FESC, GF FESC, GM FESC, GLM	— — —	2C0 2C0 2C0	3NW2-23 3NW2-31 3NW2-34	6C-F 6C-F 6C-R	965 976 977	
HRC-II MISC	Offset Center	600	K07CR L09C	K07CR, OSD L09C, CD	— CC	— FESC, GC	— —	— 2CM	— 3NW2-22	— —	— 964	
HRC-II MISC	Offset Center	600	M14C P09C	M14C, DEO P09C, ED	CFP CMF	FES, GFP FESF, GMF	— —	2CM 2CM	3NW2-14 3NW2-25	— —	945 966	
Miniature Blade	Offset	600	CIF21 CIF06	F21, NITD F06, NSD, NSC	NIT NS	GIT NSG	— —	N2B N2C	— —	— —	— —	
SMALL DIMENSION FUSES												
Size	Description	EDISON		BRUSH	CEFCO	GEC/ GOULD	LITTELFSE.	FUSETEK	NORAM			
		new	old									
5 x 20mm	Time Delay, Glass	GDC	BDC	BDC	CMB	GDG	218	SD6	SE-S			
	Fast Acting, Glass	GMA	BMA	BMA	CMA	GGM	235	MQ4	SE-F			
	Fast Acting, Glass	GDB	BDB	BDB	—	GSB	217	—	—			
	Fast Acting, Glass	GDA	—	—	—	—	216	—	—			
	Time Delay, Glass	GMC	—	—	—	GSC	—	—	—			
	Time Delay, Glass	GMD	—	—	—	GSC	239	—	—			
1/4 x 1"	Fast Acting, Glass	AGX	BGX	BGX	8AG	GGX	361/2	SL4	—			
1/4 x 1-1/4"	Fast Acting, Glass	AGC	BGC	BGC	3AG	GGC	312	SS2/SS6	SU-F			
	Fast Acting, Cer.	ABC	BBC	BBC	3AB	GAB	314	CES14	—			
	V Fast Acting, Cer.	GBB	—	—	—	—	322	—	—			
	Time Delay, Glass	MDL	BDL	BDL	BAG-SB	GDL	313	SD4	SU-S			
	Time Delay, Cer.	MDA	BDA	—	—	GSA	326	—	—			

CROSS REFERENCE GUIDE

FUSE	VOLT	EDISON	BRUSH	OLD RELIANCE/ BRUSH	GEC/CEFCO	GOULD	IR	FERRAZ	FUSETEK	LITTELFUSE	
SEMICONDUCTOR FUSES											
U.S.A. Dimensions	130/150	E13S, E15SF, E15S	XL-SF13X	RFA	CSF-15X	A13X	SF13X	A013FA	RF13X	L15S, KLV, KLA	
	250	E25S, E25SF	XL25X	RFN	CSF25X	A25X	SF25X	A025FA	RF25X	L25S, KLB	
	500	E50S, E50SF	XL50F	RFV	CSF50P	A50P	SF50P	A050FA	RF50X	L50S, KLH	
	600	E60S, E60SF	XL60X	RFS	CSF60X	A60X	SF60X	A060FA	RF60X	L60S	
	600	E60C	XL60C	RFC	—	A60X-4K	SF60C	—	—	—	
	700	E70S, E70SF	XL70F	RFL	CSF70P	A70P	SF70P	A070FA	RF70P	L70S	
	1000	E100S, E100SF	XL100P	RFK	CSF100P	A100P	SF100P	A070FB	RF100P	—	
European Dimensions	240	LCT	LCT	—	GSA	—	A350	—	URE	—	
		LET	LET	—	GSA & GSD	—	L350	—	URGS	—	
		LMT	LMT	—	GSA & GSD	—	T350	—	URGGT	—	
	660	LMMT	LMMT	—	GSA & GSD	—	TT350	—	URGHT	—	
		FC	CT, FC	—	GSB	—	B1000	—	6.6URE	—	
		FE	ET, FE	—	GSB	—	E100	—	6.6URS	—	
Trip Indicators	500	Ti500	Ti500	—	GSB, GSG	—	EE1000	—	6.6URT	—	
	700	Ti700	Ti700	—	GSB, GSG	—	M1000	—	6.6URGLT	—	

KV	BODIES	EDISON	BRUSH	GOULD	GE	CGE	WESTING- HOUSE	WESTING- HOUSE	GEC/CEFCO	NELSON	CHAMBERS	FUSETEK	
----	--------	--------	-------	-------	----	-----	-------------------	-------------------	-----------	--------	----------	---------	--

MEDIUM VOLTAGE "R" RATED MOTOR CIRCUIT FUSES													
4.8/5.5	1	5.5VFNHA2R	5.5VFNHA2R	A480-2R	9F60LJD802	328L493G14	151D241G02	208D512G02	5.5KDAX2R	70-2M-1C-5.5	48-FM-2X-4	MRP1.2R	
	1	5.5VFNHA3R	5.5VFNHA3R	A480-3R	9F60LJD803	328L493G16	151D241G03	208D512G03	5.5KDAX3R	100-3M-1C-5.5	48-FM-3X-4	MRP1.3R	
	1	5.5VFNHA4R	5.5VFNHA4R	A480-4R	9F60LJD804	328L493G17	151D241G04	208D512G04	5.5KDAX4R	130-4M-1C-5.5	48-FM-4X-4	MRP1.4R	
	1	5.5VFNHA6R	5.5VFNHA6R	A480-6R	9F60LJD806	328L493G19	151D241G06	208D512G06	5.5KDAX6R	170-6M-1C-5.5	48-FM-6X-4	MRP1.6R	
	1	5.5VFNHA9R	5.5VFNHA9R	A480-9R	9F60LJD809	328L493G21	151D961G01	208D522G01	5.5KDAX9R	200-9M-1C-5.5	48-FM-9X-4	MRP1.9R	
	1	5.5VFNHA12R	5.5VFNHA12R	A480-12R	9F60LJD812	328L493G23	151D961G02	208D522G02	5.5KDAX12R	230-12M-1C-5.5	48-FM-12X-4	MRP1.12R	
2.4/2.75	2	5.5VFNHK18R	5.5VFNHK18R	A480-18R	9F60MJD818	328L493G25	151D961G03	208D522G02	5.5KDBX18R	390-18M-2C-5.5	48-FM-18X-5	MRP1.18R	
	2	5.5VFNHK24R	5.5VFNHK24R	A480-24R	9F60MJD824	328L493G27	151D961G04	208D522G03	5.5KDBX24R	450-24M-2C-5.5	48-FM-24X-5	MRP1.24R	
	1	2.75VFRHA2R	2.75VFRHA2R	A240-2R	9F60LCB802	328L492G14	591C812G04	208D480G02	—	70-2M-1C-2.75	24-FM-2X-4	FC6005.2R	
	1	2.75VFRHA3R	2.75VFRHA3R	A240-3R	9F60LCB803	328L492G16	591C812G03	208D480G03	—	100-3M-1C-2.75	24-FM-3X-4	FC6005.3R	
	1	2.75VFRHA4R	2.75VFRHA4R	A240-4R	9F60LCB804	328L492G17	591C812G04	208D480G04	—	130-4M-1C-2.75	24-FM-4X-4	FC6005.4R	
	1	2.75VFRHA6R	2.75VFRHA6R	A240-6R	9F60LCB806	328L492G19	591C812G06	208D480G06	—	170-6M-1C-2.75	24-FM-6X-4	FC6005.6R	
	1	2.75VFRHA9R	2.75VFRHA9R	A240-9R	9F60LCB809	328L492G21	591C812G07	208D480G07	—	200-9M-1C-2.75	24-FM-9X-4	FC6005.9R	
	1	2.75VFRHA12R	2.75VFRHA12R	A240-12R	9F60LCB812	328L492G23	591C812G08	208D480G08	—	230-12M-1C-2.75	24-FM-12X-4	FC6005.12R	
	2	2.75VFRHK18R	2.75VFRHK18R	A240-18R	9F60MKB818	328L492G25	591C812G01	208D480G09	—	390-18M-2C-2.75	24-FM-18X-5	FC6005.18R	
	2	2.75VFRHK24R	2.75VFRHK24R	A240-24R	9F60MKB824	328L492G27	591C812G02	208D480G10	—	450-24M-2C-2.75	24-FM-24X-5	—	

KV	BODY LENGTH	AMPS	EDISON	GEC	B & S	DELLE
----	-------------	------	--------	-----	-------	-------

H.V. DIN DISTRIBUTION FUSES						
3.6	292mm	6-40	3.6ADLSJ	—	SOLDD	—
		50-125	3.6WDLSJ	—	SOLDD	—
		160-200	3.6WFLSJ	—	SRLDD	—
		250-400	3.6WKLSJ	—	SRLDD	—
7.2	292mm	6-31	7.2SDLSJ	DSSAX	SOLDD	FD3
		40-63	7.2SDLSJ	DSSAX	SRLDD	FD3
		180-100	7.2SFLSJ	DSSAX	SRLDD	FD3
		125-160	7.2SFLSJ	DSSBX	SRLDD	—
		200-355	7.2WKMSJ	DSLXB	SRMDD	—
12	292mm	6-50	12SDLSJ	DESAGX	—	FD4
		50-80	12SFLSJ	DESAX	—	FD4
		100	12SDLSJ	DESXB	—	—
		125	12SKLSJ	—	—	—
		6-25	17.5SDLSJ	—	SOLDD	—
17.5	292mm	31-50	17.5SFLSJ	—	SFLDD	—
		6-40	17.5SDMSJ	DFLAX	SOMDD	FD5
		40-63	17.5SFMSJ	DFLAX	SRMDD	FD5
		80	17.5SFMSJ	DFLBX	SRMDD	—
		100-125	15.5SFMSJ	DFLBX	—	—
25	442mm	6-31	24SDMSJ	DTLAX	—	FD6
		40-50	24SFMSJ	DTLAX	—	FD6
		63-71	24SFMSJ	DTLBX	—	FD6
36	537mm	3-25	36SDOSJ	DHMBX	—	FD7
		31-56	36SFOSJ	BHMBX	—	FD7

Customer Satisfaction - US and Canada

The Edison™ Customer Satisfaction team is a great resource for questions regarding all Edison products. Service hours are Monday through Friday, 8:00 a.m. – 4:30 p.m. CST.

The Customer Satisfaction team can be reached via:

- Phone: 636-391-3443
- Toll-free fax: 800-862-5178
- E-mail: edisonorders@cooperindustries.com

Online Resources

Visit www.edisonfuse.com for additional product information.

C3 – The Enhanced, Online Cooper Customer Center

Provides real time product availability, net pricing, order status & shipment for Edison distributors.

Available at:

- www.cooperc3.com
- 877-995-5955 for log-in assistance

Edison
Cooper Circuit Protection
www.edisonfuse.com

Your Authorized Edison Distributor is:

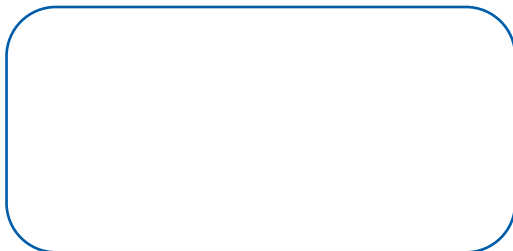

Edison

Cooper Industries, Ltd.
600 Travis, Ste. 5800
Houston, TX 77002-1001
P: 713-209-8400
www.cooperindustries.com

Reorder # 1005 0711-7.5M

Printed in USA

COOPER Circuit Protection