



Refrigeration Innovation
Natural Refrigerants Compatible

Product Catalog

Oil Separators



Reservoirs



Liquid Receivers



Oil Management



1555 West Hawthorne Lane, Suite 1E
 West Chicago, Illinois 60185-1822 USA
 Phone: 1.800.552.9300 / 1.630.293.5910
 Fax: 1.630.293.9594
 email: temprite@temprite.com
 www.temprite.com



The best way to achieve optimal refrigeration performance is to run a clean system.

The key to keeping your system clean and efficient is Temprite oil management products.

Temprite oil management products allow your refrigeration system to:

- achieve maximum refrigeration performance,
- consume less electricity and lower carbon emissions, and
- attain the highest possible return on your investment.

Since its founding in 1924, Temprite has consistently engineered and manufactured innovative products of sterling quality and long-lasting, dependable performance. In 1948, Temprite built the first separator for commercial refrigeration and designed and built the first coalescent oil separator for scientific applications in 1988, as well as the first components specifically designed for transcritical CO₂ in 2006.

Always ahead of the changing market, Temprite provides customer-driven products that meet the standards for new and natural refrigerants. Working in partnership with customers, Temprite engineers develop products that meet standards wherever their customers do business.

This is knowledge-based engineering, drawing on decades of accumulated experience. Their engineering expertise allows customers to use Temprite products with the broadest possible range of refrigerants, in the best configuration for their system. Temprite's quality of engineering and manufacture is proven by the time-tested, proven performance of its products.

As the needs of customers change, Temprite continues to meet their needs with new ideas, better technology, consistent performance, and first-quality manufacturing.

Temprite • Natural Refrigerant Compatible

The volatility challenges of natural refrigerants require smart engineering and innovative manufacturing. Temprite specializes in energy-efficient coalescent and conventional oil separators, oil reservoirs, liquid receivers and refrigerant oil management products for all refrigerants including natural refrigerants: ammonia (NH₃), carbon dioxide (CO₂) and hydrocarbons (HCs).

- The 130 Series of coalescent oil separators, reservoirs and drier shells meet the increasing demand for transcritical CO₂ products that deliver high efficiency, significant energy savings, and the potential for smart utilization of waste heat in the transcritical CO₂ environment. 130 Series products are compatible with all refrigerants at all pressures, and are suitable for subcritical CO₂ applications where pressure is above 44.8 bar (650 PSI).

130 Series oil separators have a MWP of 140 bar (2030 PSI)* and the most efficient oil-refrigerant filtering and separation technology available, with a 98.5%+ nominal separation efficiency rating across the widest range of mass flows. Connection options: ODS, BW or NPT.

* See Temprite Series 130 at www.temprite.com for details.

- The 920 & 920R Series of coalescent oil separators are compatible with all refrigerants including traditional refrigerants, subcritical CO₂, HCs and ammonia (NH₃). 920 and 920R Series separators offer easy accessibility to the Temprite Standard Filter for changes. Both Series offer a choice of Imperial or metric ODS connections.
- Temprite's 300 and 900 Series of hermetic coalescent oil separators are compatible with subcritical CO₂, hydrocarbons, and traditional refrigerants.
- The 500 Series of accessible impingement conventional oil separators are compatible with subcritical CO₂, HCs, and traditional refrigerants.
- The 600 Series of hermetic impingement conventional oil separators are compatible with subcritical CO₂, HCs, and traditional refrigerants. Models 606 and 607 are ammonia-compatible on request.

Product Certifications

Temprite's products have been UL-listed for decades. Since December 2001, all products conform to the European Pressure Directive (PED). As customer refrigeration systems can vary greatly, each Temprite design is engineered and thoroughly tested to ensure consistent performance and durability. Every time there's a new performance or safety standard to meet, Temprite products help customers meet it. Temprite products carry one or more of the following certifications: UL, ULC, CE, CRN ASME, KHK.*



* Contact Temprite for individual product certifications.

Table of Contents

Page Nos.

Temprite Coalescent Oil Separators	4
130 Series for CO ₂ : Model 131: Hermetic; Models 133A-139A: Accessible 300 Series: Hermetic; Models 320-322, 340-343 900 Series: Hermetic; Models 900, 900-1, 902-905 920 & 920R Series: Accessible; Models 922-930 & 922R-930R	
Temprite Conventional Oil Separators	14
500 Series: Accessible; Models 501-505, 506, 507 600 Series: Hermetic; Models 600-605, 606, 607	
Sizing Charts	16
920 & 920R Series: Tons 920 & 920R Series: kW 920 & 920R Series: Natural Refrigerants 300 & 900 Series 500 & 600 Series 130 Series for CO ₂ Quick Reference Chart	
Oil Management	23
Oil Level Controls: Mechanical Oil Reservoirs: 47058, 47080, 47115, 47154 Oil Reservoirs for CO ₂ Oil Return Floats Valves: A-7, OCV-20, Rotalock Valve, Y1236C TraxOil Electronic Oil Level Controls TraxOil Oil Watches	
Liquid Receivers	30
Models VR6-12, VR8-16, VR10-20, VR12-24, VR14-36, VR16-48, VR18-60	
Optional Items	32
Pressure Differential Indicator (PDI) Drier Shells for CO ₂	
Replacement Parts	33
130 Series Standard Filter Kits, Clean-Up® Filter Kits 920 & 920R Series Standard Filter Kits, Clean-Up® Filter Kits Screen Kits, Bottom & Top Plate Gaskets/O-Rings, O-Ring/Gasket Kits Float & Plate Assemblies, Sight Glasses Drier Shell Replacement Parts	

Filtration & Separation

All Temprite coalescent oil separators are equipped with a Standard Filter that uses a matrix-type borosilicate glass fiber material to do the work formerly done by impingement screens in conventional oil separators.

Illustration #1 shows how a coalescent oil separator moves oil-laden refrigerant gas into the filter and through the separator. Refrigerant pressure moves the aerosolized oil into the separator. Oil droplets separate as they enter the filter, where the oil is stripped from the refrigerant gas. These larger, heavier droplets accumulate at the edge of the filter and fall, collecting at the bottom of the separator where the clean oil is returned to the compressor. The clean refrigerant gas moves upward to the condenser.

Illustration #2 shows a cross-section of a Temprite Standard Filter. System pressure moves the refrigerant oil in aerosol form outward from the center of the filter. The filter's borosilicate fiber matrix causes the aerosolized oil to collide with other oil droplets, creating bigger oil droplets. The oil droplets are pushed to the outer edges of the filter by refrigerant flow, and fall to the bottom of the separator.

Illustration #1: Oil Separator Cross Section

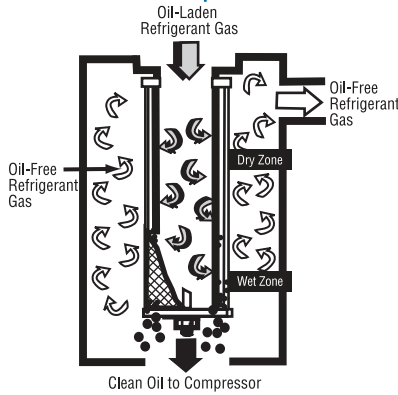
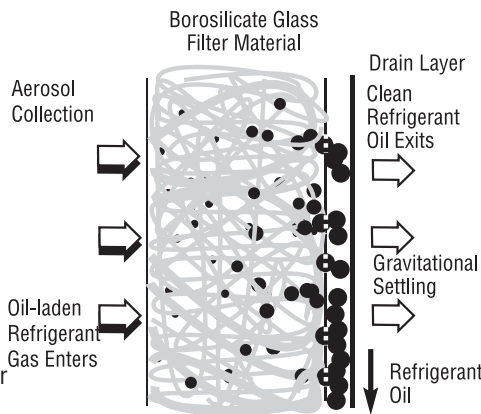

Illustration #2: Standard Filter Cross Section



Typical Aerosol Distribution in Mass Flow

Illustration #3: Aerosol Distribution

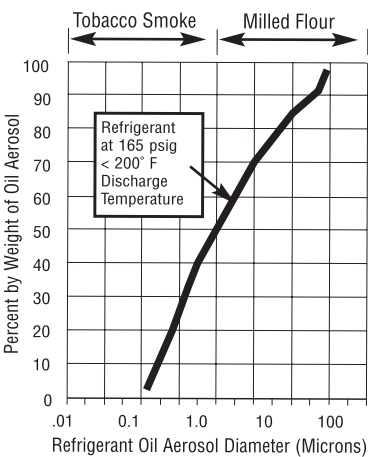

Illustration #3 shows micron particle sizes in a typical aerosol distribution ranging from .01 to 100 microns (μm) in size. Tobacco smoke and milled flour particle sizes are given as a reference point. The majority of oil droplets in refrigerant discharge gas are in the 0.4 to 10 μm range, with more than 50% of the droplets less than 1 μm in size. When evaluating the efficiency of your current separator, compare the micron cleaning range of your separator to Temprite coalescent oil separators. The exceptional Temprite Standard Filter technology cleans contaminants down to 0.3 microns in size.

Exceptional Contaminant Removal

Two of the biggest energy drains on any refrigeration system are dirt, contaminants and excess refrigerant oil. Refrigerants also have an enhanced solvent effect, meaning more contaminants than ever can be clogging your system.

Illustration #4 compares the filtration levels of all other types of separators to coalescent oil separators. Temprite filtration gives you the cleanest possible oil and refrigerant gas—the keys to energy efficiency, lower carbon emissions, longer compressor life and lower energy costs.

Temprite Product Efficiency

Temprite coalescent oil separators set the industry standard for energy-efficient performance.

"3% of oil is enough to significantly degrade performance to as high as 25%."

– ASHRAE research.

Exceptional Performance Range

- Unlike conventional separators, coalescent separators are not dependent on velocity for efficiency, maintaining 98.5% efficiency down to 20% of load.
- Coalescent separators save energy and lower electric bills by eliminating refrigerant oil coating inside of tubing, allowing better heat transfer.
- All separators rated for 44.8 bar (650 PSI) except CO_2 , rated 140 bar.*
- Temprite filters remove particulates down to 0.3 microns.
- Eliminates need for oil filters.
- Float and all components made of welded steel.
- Float balls rated for 55-58 bar (797.7-841.2 PSI) crush.
- Carry all of the governing body's stamps:



Natural Refrigerant Compatible

Temprite has engineered separators and components for compatibility with regular and natural refrigerants, including HCs, transcritical and subcritical CO_2 , and ammonia (NH_3). See individual Series information for refrigerant compatibility.

*See pages 6-7 for individual separator MWP.

Illustration #4: Coalescent Oil Separator Filtration Level

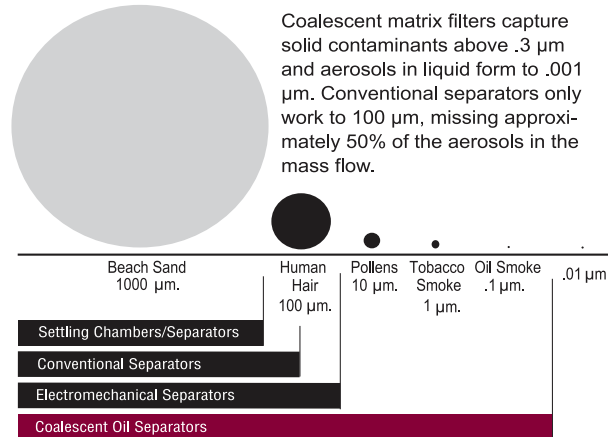

130 Series for CO₂: Hermetic and Accessible

Temprite technology addresses the challenging demands of CO₂ systems. Building on the best attributes of Temprite's 920 and 920R Series oil separation technology, the 130 Series of coalescent oil separators, reservoirs, and drier shells are designed specifically for transcritical CO₂ systems and optimized for transcritical refrigeration applications.

The 130 Series can be used for subcritical applications where pressure is above 44.8 bar (650 PSI), otherwise both the 920 and 920R Series can be used in subcritical CO₂ applications up to 44.8 bar (650 PSI),

The 130 Series are the first coalescing oil separators created for transcritical CO₂ to undergo performance testing at internationally recognized testing organizations and have proven to perform the best of any filtration and separation technology.



130 Series Technology

Specifications

- Application range: suitable for R744 (CO₂) transcritical high-, medium-, and low-temperature applications and subcritical applications above 44.8 bar (650 PSI)
- Dual function: filters dirt out of the refrigerant and oil; separates the oil from the refrigerant gas
- Maximum working pressure: 140 bar (2030 PSI)*
- Efficiency: 98.5%+ nominal separation efficiency rating
- Filtration: Sub-micron particulate retention rating
- Connection sizes: 1/2" MPT** to 2" MPT, Butt Weld or ODS** 5/8" – 2-1/8"

* Model 131 MWP 160 bar, Model 139 MWP 140 bar on request

** MPT = Male Pipe Thread, ODS = Outside Diameter Solder

Advantages

High Efficiency: most efficient oil-refrigerant filtering/separation technology with a 98.5%+ separation efficiency rating across the widest range of mass flows.

Energy-Saving: minimizes the amount of oil in the evaporator, improving heat transfer efficiency.

Cost-Saving: ensures shorter compressor run times.

Easy Filter Changing: removable top plate allows for easy filter changing after it captures excess dirt circulating in the system.*

Individually Adjustable Mounting Feet: allow for variable field leveling and adjustment.

Internal Oil Level Monitoring: the integral oil reservoir and sensor port allows monitoring of the internal oil level and the controlled return of the cleaned oil to the compressor crank case for continued lubrication of the moving parts.

* Model 131 is hermetic and the filter is not accessible for changing.

See page 24 for CO₂-compatible reservoirs and page 32 for CO₂-compatible drier shells

See page 21 for Sizing.

CO₂4U™

Temprite engineers work with customers and specialists in the CO₂ field to develop products that work with the leading refrigeration technology.

Let us know what you need for your CO₂ system. We can produce liquid receivers and other high-pressure components for CO₂ applications to meet customer requirements. See page 30 for Liquid Receivers. Contact Temprite for more information.

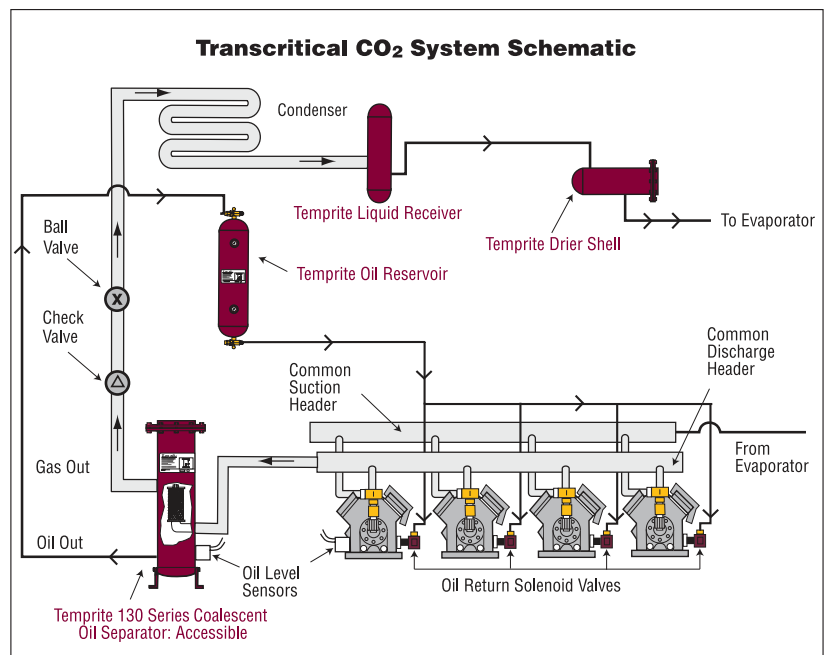

130 Series for CO₂

Model 131: Hermetic

Maximum Working Pressure: 160 bar (2320 PSI)

Part #	Model #	A Dim.	B Dim.	C Dim.	D Dim.
		Inlet/Outlet/ Oil Connector	Outlet Location	Height	Diameter
013101310	131	1/4" FPT*	115 mm 4.5"	165 mm 6.5"	73 mm 2.9"
013101311	131	3/8" FPT*	115 mm 4.5"	165 mm 6.5"	73 mm 2.9"

* FPT = Female Pipe Thread

THE CONNECTIONS ON THE OIL SEPARATOR MUST BE THE SAME SIZE AS (OR LARGER THAN) THE DISCHARGE LINE SIZE.

NOTE: See page 10 for the 920 & 920R Series of products, suitable for subcritical applications up to 44.8 bar (650 PSI).

The 920 & 920R Series are compatible with subcritical CO₂ and ammonia (NH₃).

Models 133A, 135A, 137A: Accessible

Maximum Working Pressure: 140 bar (2030 PSI)

Compatible with traditional refrigerants, new blends and natural refrigerants.*

Connection Options: ODS, BW or MPT.

Metric sizes also available: contact Temprite.

* Traditional refrigerants such as R-22 and blends like R-404a; new blends such as R-427a and R-448a; and natural refrigerants such as ammonia (NH₃) and CO₂.

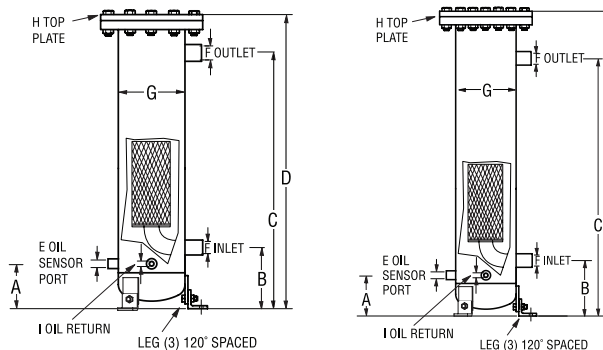

133A, 135A

137A

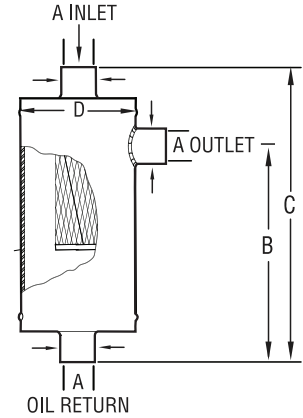

Part #	Model # Inlet/ Outlet	A Dim.	B Dim.	C Dim.	D Dim.	E Dim.	F Dim.	G Dim.	H Dim.	I Dim.
		Sensor/ Oil Loc.	Inlet Loc.	Outlet Loc.	Height	Sensor	Inlet/ Outlet	Dia.	Dia.	Oil Return
013301330	133A 1/2" MPT*	118 mm 4.6"	152 mm 6"	325 mm 12.8"	435 mm 17"	3/4" FPT*	1/2" MPT*	102 mm 4.0"	176 mm 6.9"	1/4" FPT*
013301331	133A 1/2" BW*	118 mm 4.6"	152 mm 6"	325 mm 12.8"	435 mm 17"	3/4" FPT*	1/2" BW*	102 mm 4.0"	176 mm 6.9"	1/4" FPT*
013304332	133A 5/8" ODS*	118 mm 4.6"	152 mm 6"	325 mm 12.8"	435 mm 17"	3/4" FPT*	5/8" ODS*	102 mm 4.0"	176 mm 6.9"	1/4" FPT*
013501350	135A 3/4" MPT*	118 mm 4.6"	152 mm 6"	433 mm 17.1"	545 mm 21.4"	3/4" FPT*	3/4" MPT*	102 mm 4.0"	176 mm 6.9"	1/4" FPT*
013501351	135A 3/4" BW*	118 mm 4.6"	152 mm 6"	433 mm 17.1"	545 mm 21.4"	3/4" FPT*	3/4" BW*	102 mm 4.0"	176 mm 6.9"	1/4" FPT*
013504352	135A 7/8" ODS*	118 mm 4.6"	152 mm 6"	433 mm 17.1"	545 mm 21.4"	3/4" FPT*	7/8" ODS*	102 mm 4.0"	176 mm 6.9"	1/4" FPT*
013701042	137A 1" MPT*	131 mm 5.1"	171 mm 6.7"	584 mm 23"	702 mm 27.6"	3/4" FPT*	1" MPT*	141 mm 5.56"	216 mm 8.5"	1/4" FPT*
013701370	137A 1-1/4" MPT*	131 mm 5.1"	171 mm 6.7"	584 mm 23"	702 mm 27.6"	3/4" FPT*	1-1/4" MPT*	141 mm 5.56"	216 mm 8.5"	1/4" FPT*
013701375	137A 1" BW*	131 mm 5.1"	171 mm 6.7"	584 mm 23"	702 mm 27.6"	3/4" FPT*	1" BW*	141 mm 5.56"	216 mm 8.5"	1/4" FPT*
013701371	137A 1-1/4" BW*	131 mm 5.1"	171 mm 6.7"	584 mm 23"	702 mm 27.6"	3/4" FPT*	1-1/4" BW*	141 mm 5.56"	216 mm 8.5"	1/4" FPT*
013704375	137A 1-1/8" ODS*	131 mm 5.1"	171 mm 6.7"	584 mm 23"	702 mm 27.6"	3/4" FPT*	1-1/8" ODS*	141 mm 5.56"	216 mm 8.5"	1/4" FPT*
013704372	137A 1-3/8" ODS*	131 mm 5.1"	171 mm 6.7"	584 mm 23"	702 mm 27.6"	3/4" FPT*	1-3/8" ODS*	141 mm 5.56"	216 mm 8.5"	1/4" FPT*

* FPT = Female Pipe Thread, MPT = Male Pipe Thread, BW = Butt Weld, ODS = Outside Diameter Solder

THE CONNECTIONS ON THE OIL SEPARATOR MUST BE THE SAME SIZE AS (OR LARGER THAN) THE DISCHARGE LINE SIZE.

NOTES: See page 10 for the 920 & 920R Series of products, suitable for subcritical applications up to 44.8 bar (650 PSI). The 920 & 920R Series are compatible with subcritical CO₂ and ammonia (NH₃).

See page 24 for CO₂-compatible reservoirs and page 32 for CO₂-compatible drier shells.

See page 21 for Sizing.

130 Series for CO₂

Maximum Working Pressure: 140 bar (2030 PSI)

Model 138A: Accessible

Compatible with traditional refrigerants, new blends and natural refrigerants.*

Connection Options: ODS, BW or MPT.

Metric sizes also available: contact Temprite.

* Traditional refrigerants such as R-22 and blends like R-404a; new blends such as R-427a and R-448a; and natural refrigerants such as ammonia (NH₃) and CO₂.

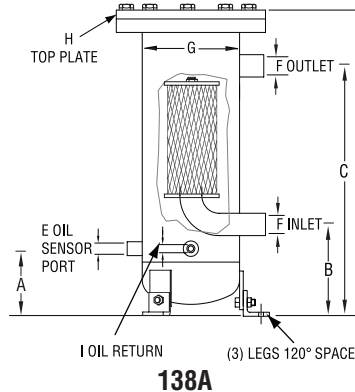

Part #	Model # Inlet/ Outlet	A Dim.	B Dim.	C Dim.	D Dim.	E Dim.	F Dim.	G Dim.	H Dim.	I Dim
		Oil Sensor/ Port	Inlet	Outlet	Height	Sensor	Inlet/ Outlet	Dia.	Dia.	Oil Return
013801380	138A 1-1/2" MPT*	131 mm 5.1"	171 mm 6.7"	752 mm 29.6"	870 mm 34.2"	3/4" FPT*	1-1/2" MPT*	141 mm 5.6"	216 mm 8.5"	1/4" FPT*
013801381	138A 1-1/2" BW*	131 mm 5.1"	171 mm 6.7"	752 mm 29.6"	870 mm 34.2"	3/4" FPT*	1-1/2" BW*	141 mm 5.6"	216 mm 8.5"	1/4" FPT*
013804382	138A 1-5/8" ODS*	131 mm 5.1"	171 mm 6.7"	752 mm 29.6"	870 mm 34.2"	3/4" FPT*	1-5/8" ODS*	141 mm 5.6"	216 mm 8.5"	1/4" FPT*

* FPT = Female Pipe Thread, MPT = Male Pipe Thread, BW = Butt Weld, ODS = Outside Diameter Solder

Model 139A: Accessible

Maximum Working Pressure: 130 bar (1885 PSI)
140 bar available upon request.

Compatible with traditional refrigerants, new blends and natural refrigerants.*

Connection Options: ODS, BW or MPT.

Metric sizes also available: contact Temprite.

* Traditional refrigerants such as R-22 and blends like R-404a; new blends such as R-427a and R-448a; and natural refrigerants such as ammonia (NH₃) and CO₂.

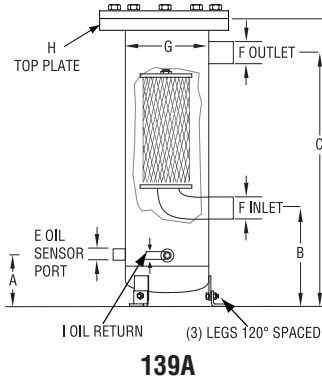

Part #	Model # Inlet/ Outlet	A Dim.	B Dim.	C Dim.	D Dim.	E Dim.	F Dim.	G Dim.	H Dim.	I Dim.
		Sensor/ Oil Loc.	Inlet Loc.	Outlet Loc.	Height	Sensor	Inlet/ Outlet	Dia.	Dia.	Oil Return
013911391	139A 1-1/2" BW*	162 mm 6.4"	210 mm 8.3"	765 mm 30.1"	927 mm 36.5"	3/4" FPT*	1-1/2" BW*	219 mm 8.6"	324 mm 12.75"	1/4" FPT*
013921392	139A 2" BW*	162 mm 6.4"	210 mm 8.3"	765 mm 30.1"	927 mm 36.5"	3/4" FPT*	2" BW*	219 mm 8.6"	324 mm 12.75"	1/4" FPT*
013904392	139A 1-5/8" ODS*	162 mm 6.4"	210 mm 8.3"	765 mm 30.1"	927 mm 36.5"	3/4" FPT*	1-5/8" ODS*	219 mm 8.6"	324 mm 12.75"	1/4" FPT*
013904395	139A 2-1/8" ODS*	162 mm 6.4"	210 mm 8.3"	765 mm 30.1"	927 mm 36.5"	3/4" FPT*	2-1/8" ODS*	219 mm 8.6"	324 mm 12.75"	1/4" FPT*

* FPT = Female Pipe Thread, MPT = Male Pipe Thread, BW = Butt Weld, ODS = Outside Diameter Solder

THE CONNECTIONS ON THE OIL SEPARATOR MUST BE THE SAME SIZE AS (OR LARGER THAN) THE DISCHARGE LINE SIZE.

NOTES: See page 10 for the 920 & 920R Series of products, suitable for subcritical applications up to 44.8 bar (650 PSI). The 920 & 920R Series are compatible with subcritical CO₂ and ammonia (NH₃).

See page 24 for CO₂-compatible reservoirs and page 32 for CO₂-compatible drier shells.

See page 21 for Sizing.

Temprite® Coalescent Oil Separators

300 Series: Hermetic

Maximum Working Pressure: 44.8 bar (650 PSI)

Compatible with all traditional refrigerants including HCs and Subcritical CO₂

Temprite's 300 Series of hermetic coalescent oil separators are one of the smallest oil separators available for their capacity.

- 320 and 340 Series units are 99.995% efficient in removing particulates between 0.3 and 0.6 microns (µm) and separating oil from the mass flow. The elimination of the float ball and internal oil reservoir maximizes efficiency by minimizing oil carryover.

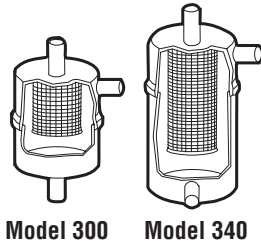

- Metering the oil return back to the compressor may be done by a variety of methods including a capillary tube, a metered orifice or a timed solenoid.

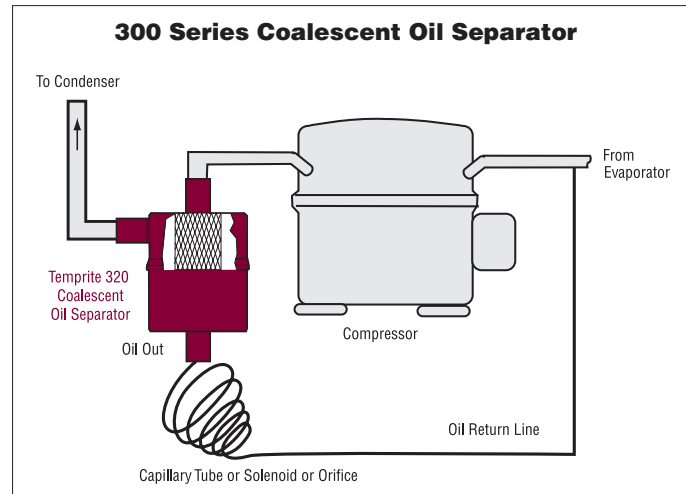

Models 320-322

Part #	Model #	A Dim./Oil Conn. Size	B Dim.	C Dim.	D Dim.
032000000	320	3/8" ODS* 9.53 mm	2-1/16" 52 mm	4-1/4" 108 mm	2-1/2" 64 mm
032100000	321	1/8" FPT*	2-1/16" 52 mm	3-1/2" 89 mm	2-1/2" 64 mm
032200000	322	1/4" SAE*	2-1/16" 52 mm	4" 102 mm	2-1/2" 64 mm

* FPT = Female Pipe Thread, ODS = Outside Diameter Solder, SAE = 45° Flare Connection

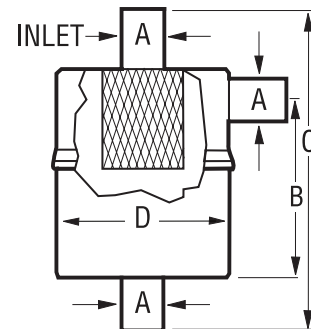

Models 340-343

Part #	Model #	A Dim./ Oil Conn. Size	B Dim.	C Dim.	D Dim.
034000000	340	3/8" ODS* 9.53 mm	3-9/16" 90 mm	4-7/8" 124 mm	2-1/2" 64 mm
034100000	341	1/8" FPT*	3-9/16" 90 mm	4-1/2" 114 mm	2-1/2" 64 mm
034200000	342	1/4" SAE*	3-9/16" 90 mm	4-3/4" 121 mm	2-1/2" 64 mm
034300000	343	3/8" SAE*	3-9/16" 90 mm	4-15/16" 125 mm	2-1/2" 64 mm

* FPT = Female Pipe Thread, ODS = Outside Diameter Solder, SAE = 45° Flare Connection

THE CONNECTIONS ON THE OIL SEPARATOR MUST BE THE SAME SIZE AS (OR LARGER THAN) THE DISCHARGE LINE SIZE.

See page 19 for Sizing.

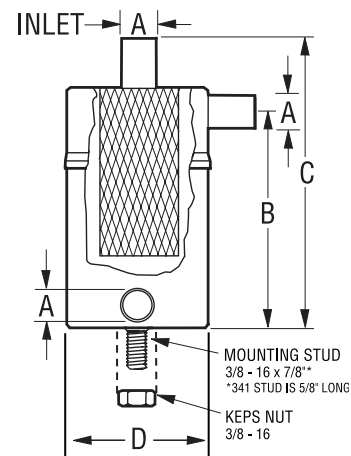

900 Series: Hermetic

Compatible with HCs and Subcritical CO₂

Maximum Working Pressure: 44.8 bar (650 PSI)

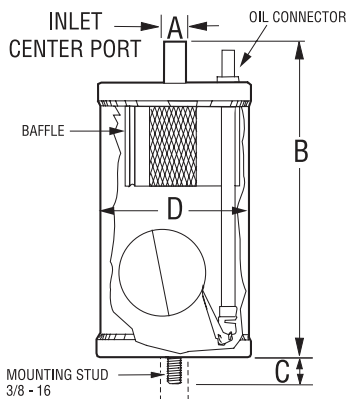

900, 900-1, 901

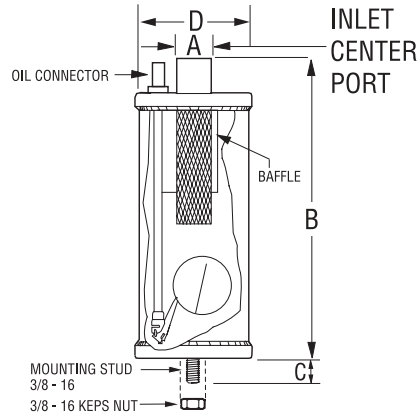

902, 903

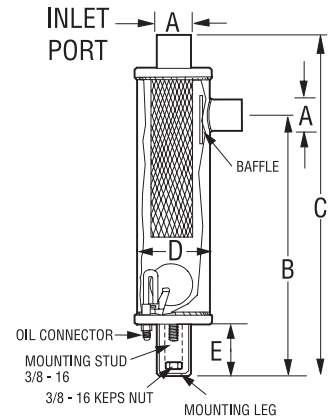

904, 905

Models 900, 900-1, 901

Part #	Model #	Oil Conn. Size	A Dim.	B Dim.	C Dim.	D Dim.	Oil Charge Amt.
090000000	900	1/4" ODS* 6.35 mm	3/8" ODS* 9.53 mm	8-1/4" 210 mm	3/4" 19 mm	4" 102 mm	15 oz. 445 ml.
090081000	900-1	1/4" 90° ODS* 6.35 mm	3/8" ODS* 9.53 mm	8-1/4" 210 mm	3/4" 19 mm	4" 102 mm	15 oz. 445 ml.
090100000	901	1/4" ODS* 6.35 mm	1/2" ODS* 12.70 mm	8-3/8" 213 mm	3/4" 19 mm	4" 102 mm	15 oz. 445 ml.

Models 902, 903

Part #	Model #	Oil Conn. Size	A Dim.	B Dim.	C Dim.	D Dim.	Oil Charge Amt.
090200000	902	1/4" ODS* 6.35 mm	5/8" ODS* 15.88 mm	10-9/16" 268 mm	3/4" 19 mm	4" 102 mm	15 oz. 445 ml.
090300000	903	1/4" ODS* 6.35 mm	7/8" ODS* 22.23 mm	10-7/8" 276 mm	3/4" 19 mm	4" 102 mm	15 oz. 445 ml.

Models 904, 905

Part #	Model #	Oil Conn. Size	A Dim.	B Dim.	C Dim.	D Dim.	E Dim.	Oil Charge Amt.
090400000	904	1/4" ODS* 6.35 mm	1-1/8" ODS* 28.58 mm	15-1/8" 384 mm	18-3/8" 467 mm	4" 102 mm	3" 76 mm	16 oz. 475 ml.
090500000	905	1/4" ODS* 6.35 mm	1-3/8" ODS* 34.93 mm	15-1/8" 384 mm	18-3/8" 467 mm	4" 102 mm	3" 76 mm	16 oz. 475 ml.

* ODS = Outside Diameter Solder

THE CONNECTIONS ON THE OIL SEPARATOR MUST BE THE SAME SIZE AS (OR LARGER THAN) THE DISCHARGE LINE SIZE.

See page 19 for Sizing.

920 & 920R Series Coalescent Oil Separators: Accessible

Compatible with all traditional refrigerants including HCs, Ammonia (NH₃), and Subcritical CO₂



920 Series

Lower Energy Costs & Carbon Emissions

The energy-efficient 920 & 920R Series of coalescent oil separators are designed for maximum energy efficiency. Temprite separators make refrigeration systems clean and green by lowering energy costs and reducing carbon emissions.

The 920R Series delivers the:

- Highest measured capacity of refrigeration.
- Lowest kilowatts required per unit of cooling (per ton).

Large-Scale Refrigeration Cost Savings

In large parallel rack/multiplex systems with long lines, dirt and excess oil put an even greater drag on system efficiency.

- Both problems are eliminated with the 920 & 920R Series separators, increasing system capacity and efficiency and lowering energy costs.
- Energy savings scale up with larger systems.



920R Series

Compatible with HCs, Ammonia (NH₃)*, and Subcritical CO₂

Both 920 & 920R Series are compatible with HCs, ammonia (NH₃), and subcritical CO₂ and designed for 44.8 bar (650 PSI). (For subcritical CO₂ above 44.8 bar, see 130 Series on page 5.)*

920 & 920R separators offer easy accessibility to the Temprite Standard Filter for changes. Other products require disassembling and re-welding the separator for filter changes. Because ammonia is a cleaning agent, more dirt is removed from the system and deposited in the filter. *To order ammonia-compatible models, change the last three digits of the part number to "717." Example: 092600000 changes to 092600717.

Both Series offer a choice of Imperial or metric ODS connections. Check with Temprite for metric sizes.

External Reservoir

All 920 Series models are designed for use with an external reservoir.

"R" is For Reservoir

An oil reservoir is built into each 920R Series coalescent oil separator. The built-in reservoir reduces piping, components and potential leaks and creates a stable, high-pressure oil system.

Because the oil reservoir is built-in, 920R Series separators do not have a float.

The 920 & 920R Series
Cost Savings
Calculator

<input checked="" type="radio"/> IP - BTUS, °F, etc. <input type="radio"/> SI - kW, °C, etc. US Dollar		How to Use?	
MEDIUM TEMPERATURE (+20° F)		LOW TEMPERATURE (-20° F)	
System Capacity in Tons (Example: 100)	<input type="text" value="100"/>	System Capacity in Tons (Example: 67)	<input type="text" value="67"/>
Electrical Consumption Improvement in kW/Tons*	X <input type="text" value="0.011"/>	Electrical Consumption Improvement in kW/Tons*	X <input type="text" value="0.018997"/>
Run Hours/Day (Example: 24)	X <input type="text" value="24"/>	Run Hours/Day (Example: 24)	X <input type="text" value="24"/>
Energy Cost kWh (Example: \$.085)	X <input type="text" value=".085"/>	Energy Cost kWh (Example: \$.085)	X <input type="text" value=".085"/>
Run Days per Year (Example: 365)	X <input type="text" value="365"/>	Run Days per Year (Example: 365)	X <input type="text" value="365"/>
Annual Savings per Store	= \$819.06	Annual Savings per Store	= \$947.73
CHAIN WIDE/LIFE OF SYSTEM SAVINGS			
Low Temp + Med Temp Savings	<input type="text" value="\$1,766.79"/>	Annual Savings	<input type="text" value="\$17,667.86"/>
Number of Stores	X <input type="text" value="10"/>	10 Year Estimated Life of System	<input type="text" value="\$176,678.61"/>

* Delta between Temprite 920 Series and Henry Helical.
Temprite kW/Tons savings will be even greater due to higher efficiency during unloading conditions.

Print CALCULATE

920 & 920R Cost Savings Calculator

Temprite's 920 & 920R Series "Cost Savings Calculator" allows you to see how much energy and money you'll save using coalescent oil separators based on your system, price of energy, run days and total capacity. You'll see how savings increase based on the number of stores, both annually and for the 10-year life of system, and how carbon emissions are reduced. Coalescing separators remove 95% to 99% of the oil from a system's mass flow while maintaining the same level of effectiveness regardless of system velocities and loads. This is especially important for large-scale refrigeration systems: 60% of a grocery store's cost of operation is refrigeration. Visit www.temprite.com and find out how much you can save. (Savings Calculator works with both Imperial and metric input.)

920 & 920R Series: Accessible

Maximum Working Pressure: 44.8 bar (650 PSI)

Compatible with all traditional refrigerants including HCs, ammonia (NH₃) and subcritical CO₂.

To order ammonia-compatible models, change the last three digits of the part number to "717."

Example: 09260000 changes to 092600717. Check with Temprite for metric sizes.

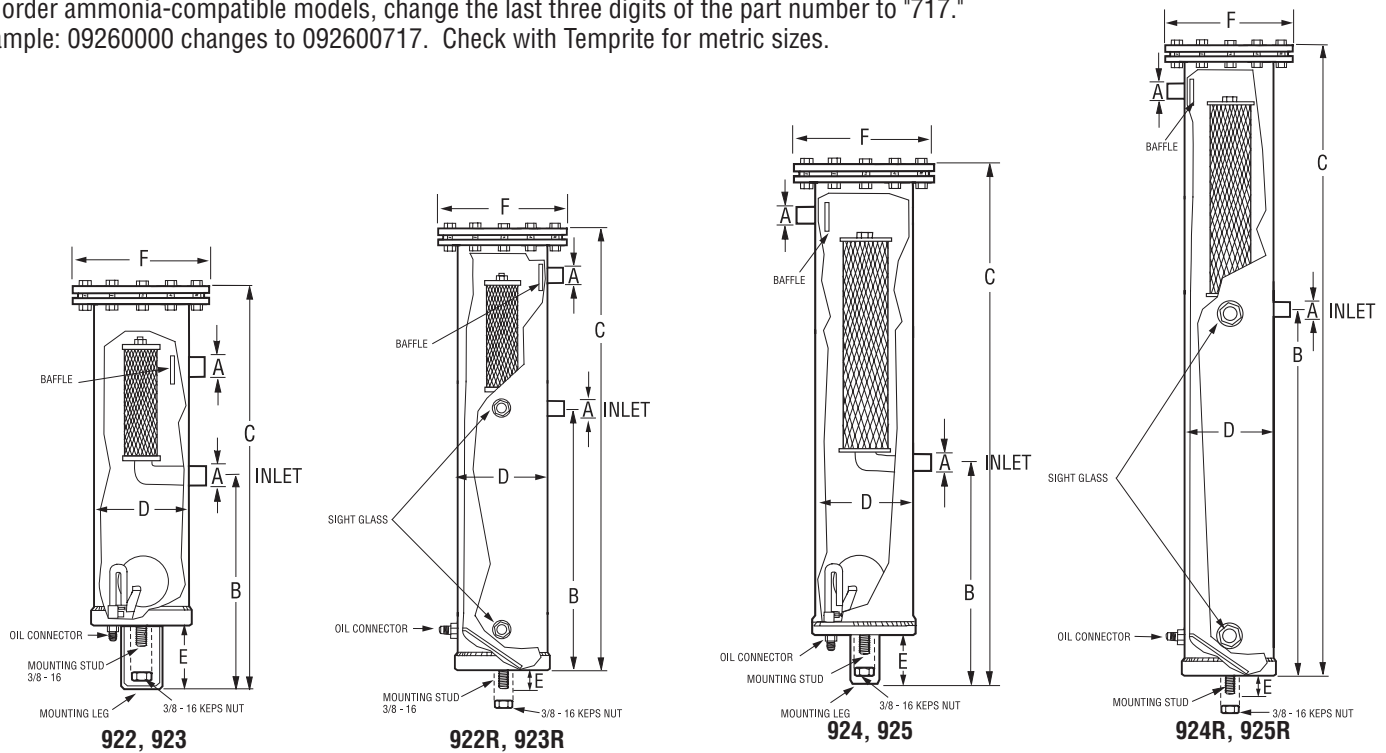

Models 922, 923, 922R, 923R

Part #	Model #	Oil Conn. Size	A Dim.	B Dim.	C Dim.	D Dim.	E Dim.	F Dim.	Oil Charge Amt.
092200000	922	1/4" SAE*	5/8" ODS* 15.88 mm	9-3/8" 238 mm	17-1/4" 438 mm	4" 102 mm	3" 76 mm	6-1/2" 165 mm	16 oz. 475 ml.
092300000	923	1/4" SAE*	7/8" ODS* 22.23 mm	9-3/8" 238 mm	17-1/4" 438 mm	4" 102 mm	3" 76 mm	6-1/2" 165 mm	16 oz. 475 ml.
092201000	922R	1/4" SAE*	5/8" ODS* 15.88 mm	11-5/8" 295 mm	19-1/2" 495 mm	4" 102 mm	3/4" 19 mm	6-1/2" 165 mm	77 oz. 2.27 Liters
092301000	923R	1/4" SAE*	7/8" ODS* 22.23 mm	11-5/8" 295 mm	19-1/2" 495 mm	4" 102 mm	3/4" 19 mm	6-1/2" 165 mm	77 oz. 2.27 Liters

Models 924, 925, 924R, 925R

Part #	Model #	Oil Conn. Size	A Dim.	B Dim.	C Dim.	D Dim.	E Dim.	F Dim.	Oil Charge Amt.
092400000	924	1/4" SAE*	1-1/8" ODS* 28.58 mm	9-3/8" 238 mm	21-5/8" 549 mm	4" 102 mm	3" 76 mm	6-1/2" 165 mm	16 oz. 475 ml.
092500000	925	1/4" SAE*	1-3/8" ODS* 34.93 mm	9-3/8" 238 mm	21-5/8" 549 mm	4" 102 mm	3" 76 mm	6-1/2" 165 mm	16 oz. 475 ml.
092401000	924R	1/4" SAE*	1-1/8" ODS* 28.58 mm	16-3/8" 416 mm	28-5/8" 727 mm	4" 102 mm	3/4" 19 mm	6-1/2" 165 mm	109 oz. 3.22 Liters
092501000	925R	1/4" SAE*	1-3/8" ODS* 34.93 mm	16-3/8" 416 mm	28-5/8" 727 mm	4" 102 mm	3/4" 19 mm	6-1/2" 165 mm	109 oz. 3.22 Liters

* SAE = 45° Flare Connection, ODS = Outside Diameter Solder

See pages 16-18 for sizing.

920 & 920R Series: Accessible

Maximum Working Pressure: 44.8 bar (650 PSI)

Compatible with all traditional refrigerants including HCs, ammonia (NH₃) and subcritical CO₂. To order ammonia-compatible models, change the last three digits of the part number to "717." Example: 09260000 changes to 092600717. Check with Temprite for metric sizes.

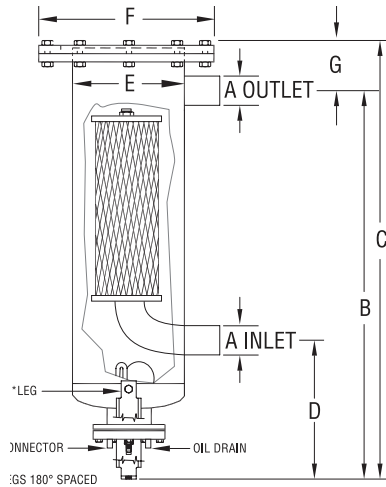

926, 927

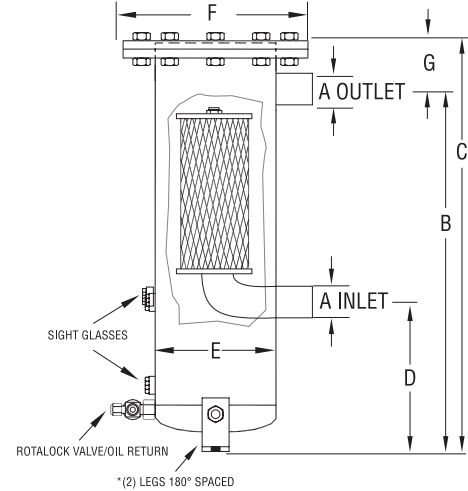

926R, 927R

Models 926, 927, 926R, 927R

Part #	Model #	Oil Conn. Size	A Dim.	B Dim.	C Dim.	D Dim.	E Dim.	F Dim.	G Dim.	Oil Charge Amt.
092600000	926	3/8" SAE*	1-5/8" ODS* 41.28 mm	29-7/16" 748 mm	35" 889 mm	12" 305 mm	6" 152 mm	8-1/2" 216 mm	4-1/2" 114 mm	34 oz. 1 Liters
092700000	927	3/8" SAE*	2-1/8" ODS* 53.98 mm	29-7/16" 748 mm	35" 889 mm	12" 305 mm	6" 152 mm	8-1/2" 216 mm	4-1/2" 114 mm	34 oz. 1 Liters
092601000	926R	3/8" SAE*	1-5/8" ODS* 41.28 mm	33-7/8" 860 mm	38-3/8" 975 mm	16-5/8" 422 mm	6" 152 mm	8-1/2" 216 mm	4-1/2" 114 mm	1.8 Gal. 6.7 Liters
092701000	927R	3/8" SAE*	2-1/8" ODS* 53.98 mm	33-7/8" 860 mm	38-3/8" 975 mm	16-5/8" 422 mm	6" 152 mm	8-1/2" 216 mm	4-1/2" 114 mm	1.8 Gal. 6.7 Liters

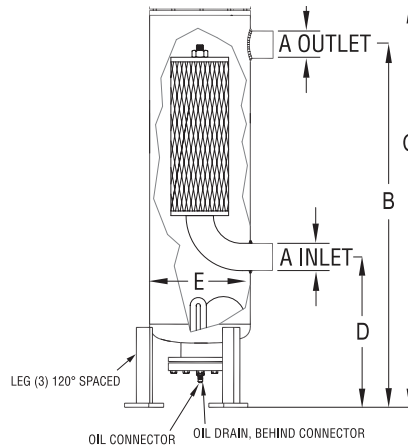

928

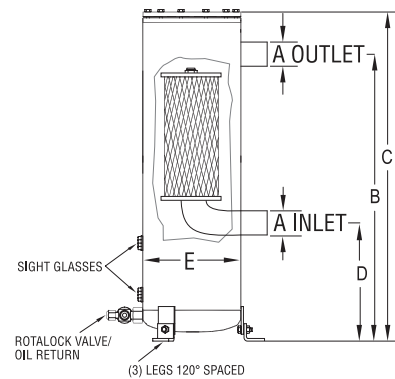

928R

Models 928, 928R

Part #	Model #	Oil Conn. Size	A Dim.	B Dim.	C Dim.	D Dim.	E Dim.	Oil Charge Amt.
092800000	928	3/8" SAE*	2-5/8" ODS* 67 mm	33-5/8" 854 mm	39-1/2" 1003 mm	12-3/4" 324 mm	8-5/8" 219 mm	34 oz. 1 Liters
092801000	928R	3/8" SAE*	2-5/8" ODS* 67 mm	32-3/8" 822 mm	37" 940 mm	11-1/2" 292 mm	8-5/8" 219 mm	2.0 Gal. 7.55 Liters

* SAE = 45° Flare Connection, ODS = Outside Diameter Solder

See pages 16-18 for Sizing.

920 & 920R Series: Accessible

Maximum Working Pressure: 44.8 bar (650 PSI)

Models 930, 930R

Compatible with HCs, ammonia (NH₃) and subcritical CO₂. To order ammonia-compatible models, change the last three digits of the part number to "717." Example: 09260000 changes to 092600717. Check with Temprite for metric sizes.

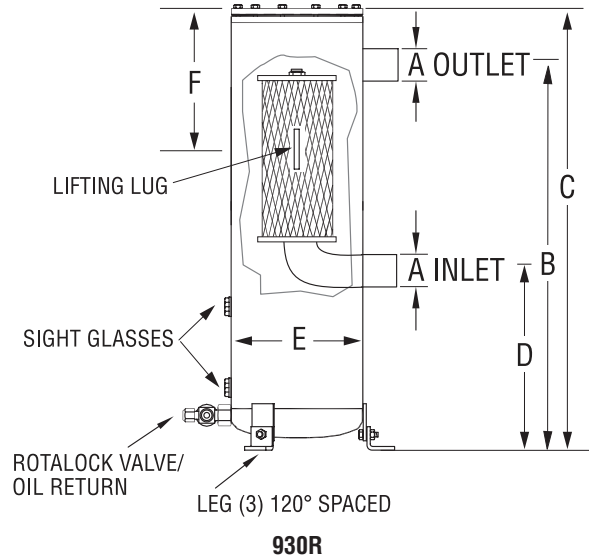
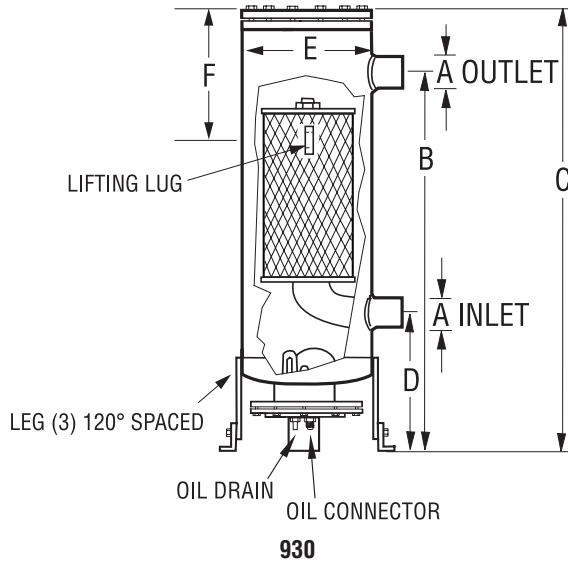

Part #	Model #	Oil Conn. Size	A Dim.	B Dim.	C Dim.	D Dim.	E Dim.	F Dim.	Oil Charge Amt.
093000000	930	3/8" SAE*	3-1/8" ODS* 79.38 mm	35-3/4" 908 mm	41-3/8" 1050 mm	13-3/4" 349 mm	12-3/4" 324 mm	11" 279 mm	85 oz. 2.5 Liters
093001000	930R	3/8" SAE*	3-1/8" ODS* 79.38 mm	37-1/8" 943 mm	42-3/4" 1085 mm	15-1/8" 384 mm	12-3/4" 324 mm	11" 279 mm	5.7 Gal. 21.25 Liters

* SAE = 45° Flare Connection, ODS = Outside Diameter Solder

THE CONNECTIONS ON THE OIL SEPARATOR MUST BE THE SAME SIZE AS (OR LARGER THAN) THE DISCHARGE LINE SIZE.

NOTE: All separators can be purchased with a Clean-Up® Filter installed by adding CNF to the end of the part number.

When ordering with the Clean-Up® Filter installed you do not get a spare filter. Call for pricing and lead times.

300/900/920/920R Series Notes

For applications other than reciprocating and scroll compressors, (screw type, two-stage) please contact Temprite engineering.

920/920R Series Notes

1. All products rated for subcritical CO₂ applications and R-410A applications (Max 650 PSIG).

2. The "R" stands for "Reservoir" and does not have a float to control oil return.

See pages 16-18 for Sizing.

Temprite Standard & Clean-Up® Filters



The Temprite Standard Filter employs a matrix-type borosilicate coalescent filter. These exceptionally pure, extremely fine glass fibers cause the oil molecules to collide, creating bigger droplets, until each is large enough to be forced to the outer drain layer of the filter. The droplets fall to the bottom of the separator and the oil is returned to the compressor. Because the Temprite Standard Filter is finer than any other filter, it picks up all effluent and dirt in the system down to 0.3 microns in size.

Temprite's Clean-Up® Filters are made of pleated fiber paper that is best suited for cleaning up a very dirty system. After a burnout, just install a Clean-Up® Filter to purge the system of contaminants and you can return the oil to near-virgin state.

500 & 600 Series

Maximum Working Pressure: 44.8 bar (650 PSI)

The Temprite 500 & 600 Series Conventional Oil Separators are impingement screen separators. In these units, the compressed mass flow enters a larger separator chamber, lowering the velocity of the mass. The atomized oil droplets collect on the impingement screen surface, and as the oil drops become larger they fall to the bottom of the separator.

500 Series Conventional Oil Separators: Accessible Impingement

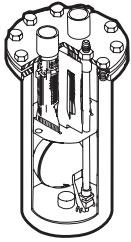

- The 500 Series is designed for the OEM who needs oil separation and accessibility to the unit for filter changes.



Models 501, 502, 503, 504, 505

Compatible with HCs and subcritical CO₂.

Part #	Model #	Oil Conn. Size	A Dim.	B Dim.	C Dim.	D Dim.	E Dim.	Oil Charge Amt.
050100000	501	1/4" SAE*	1/2" ODS* 12.70 mm	10-1/4" 260 mm	3/4" 19 mm	4" 102 mm	5-1/2" 140 mm	16 oz. 475 ml.
050200000	502	1/4" SAE*	5/8" ODS* 15.88 mm	12-7/8" 327 mm	3/4" 19 mm	4" 102 mm	5-1/2" 140 mm	16 oz. 475 ml.
050300000	503	1/4" SAE*	7/8" ODS* 22.23 mm	14-5/8" 371 mm	3/4" 19 mm	4" 102 mm	5-1/2" 140 mm	16 oz. 475 ml.
050400000	504	1/4" SAE*	1-1/8" ODS* 28.58 mm	15-1/2" 394 mm	3/4" 19 mm	4" 102 mm	5-1/2" 140 mm	16 oz. 475 ml.
050500000	505	1/4" SAE*	1-3/8" ODS* 34.93 mm	18-7/8" 479 mm	3/4" 19 mm	4" 102 mm	5-1/2" 140 mm	16 oz. 475 ml.

* SAE = 45° Flare Connection, ODS = Outside Diameter Solder

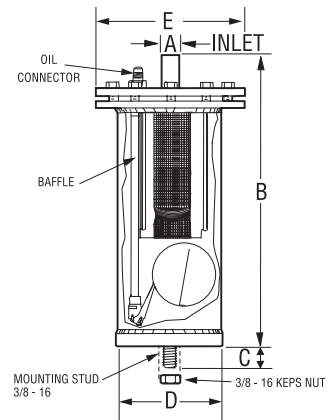

500, 501, 502, 503, 504, 505

Models 506, 507

Compatible with HC, subcritical CO₂, and ammonia (NH₃) upon request.

To order ammonia-compatible models, change the last three digits of the part number to "717." Example: 09260000 changes to 092600717.

Part #	Model #	Oil Conn. Size	A Dim.	B Dim.	C Dim.	D Dim.	Oil Charge Amt.
050600000	506	3/8" SAE*	1-5/8" ODS* 41.28 mm	15-1/4" 387 mm	20-1/4" 514 mm	6" 152 mm	20 oz. 590 ml.
050700000	507	3/8" SAE*	2-1/8" ODS* 53.98 mm	16-1/4" 413 mm	21-1/4" 540 mm	6" 152 mm	20 oz. 590 ml.

* SAE = 45° Flare Connection, ODS = Outside Diameter Solder

THE CONNECTIONS ON THE OIL SEPARATOR MUST BE THE SAME SIZE AS (OR LARGER THAN) THE DISCHARGE LINE SIZE.

See page 20 for Sizing.

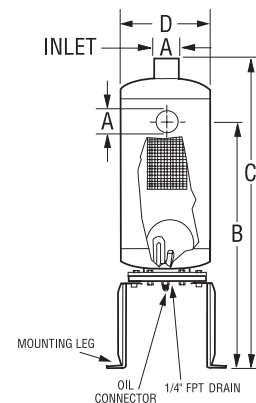

506, 507

500 & 600 Series

The Temprite 500 & 600 Series Conventional Oil Separators are impingement screen separators. In these units, the compressed mass flow enters a larger separator chamber, lowering the velocity of the mass. The atomized oil droplets collect on the impingement screen surface, and as the oil drops become larger they fall to the bottom of the separator.

600 Series Conventional Oil Separators: Hermetic Impingement

Compatible with HCs and subcritical CO₂.

Maximum Working Pressure: 44.8 bar (650 PSI)

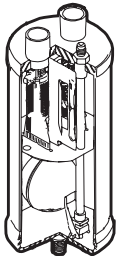

- The 600 Series is designed for the OEM who needs oil separation but does not require the accessibility of the 500 Series.



Models 600, 601, 602, 603, 604, 605

Part #	Model #	Oil Conn. Size	A Dim.	B Dim.	C Dim.	D Dim.	Oil Charge Amt.
060000000	600	1/4" SAE*	3/8" ODS* 9.53 mm	8-1/8" 206 mm	3/4" 19 mm	4" 102 mm	12 oz. 355 ml.
060100000	601	1/4" SAE*	1/2" ODS* 12.70 mm	10-1/4" 260 mm	3/4" 19 mm	4" 102 mm	12 oz. 355 ml.
060200000	602	1/4" SAE*	5/8" ODS* 15.88 mm	12-7/8" 327 mm	3/4" 19 mm	4" 102 mm	12 oz. 355 ml.
060300000	603	1/4" SAE*	7/8" ODS* 22.23 mm	14-5/8" 371 mm	3/4" 19 mm	4" 102 mm	12 oz. 355 ml.
060400000	604	1/4" SAE*	1-1/8" ODS* 28.58 mm	15-1/2" 394 mm	3/4" 19 mm	4" 102 mm	12 oz. 355 ml.
060500000	605	1/4" SAE*	1-3/8" ODS* 34.93 mm	18-7/8" 479 mm	3/4" 19 mm	4" 102 mm	12 oz. 355 ml.

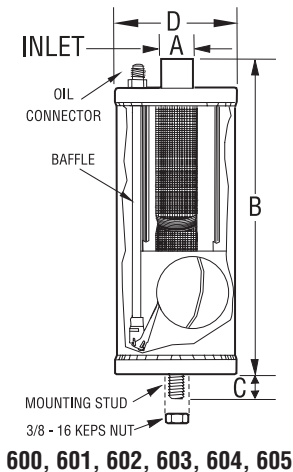

* SAE = 45° Flare Connection, ODS = Outside Diameter Solder

Models 606, 607

Compatible with HCs, subcritical CO₂ and ammonia (NH₃) upon request.

To order ammonia-compatible models, change the last three digits of the part number to "717." Example: 09260000 changes to 092600717.

Part #	Model #	Oil Conn. Size	A Dim.	B Dim.	C Dim.	D Dim.	E Dim.	Oil Charge Amt.
060600000	606	1/4" SAE*	1-5/8" ODS* 41.28 mm	13-1/2" 343 mm	18-3/8" 467 mm	6" 152 mm	3" 76 mm	29 oz. 850 ml.
060700000	607	1/4" SAE*	2-1/8" ODS* 53.98 mm	14-1/2" 368 mm	19-3/8" 492 mm	6" 152 mm	3" 76 mm	29 oz. 850 ml.

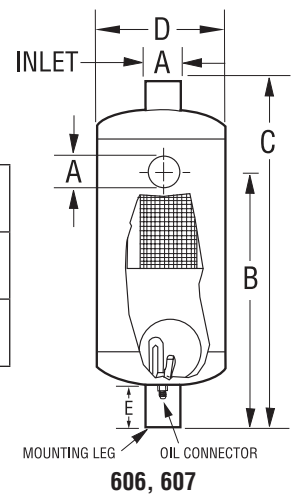

* SAE = 45° Flare Connection, ODS = Outside Diameter Solder

THE CONNECTIONS ON THE OIL SEPARATOR MUST BE THE SAME SIZE AS (OR LARGER THAN) THE DISCHARGE LINE SIZE.

600 through 607 Series separators are all welded construction with no access to internal components.

See page 20 for Sizing.

Temprite 920 & 920R Series: Capacities in Tons

Refrigerant	Model	922 922R	923 923R	924 924R	925 925R	926 926R	927 927R	928 928R	930 930R
	Connection Size	5/8"	7/8"	1-1/8"	1-3/8"	1-5/8"	2-1/8"	2-5/8"	3-1/8"
Temp °F	Tons @ 100°F Condensing 10°F Superheat 0°F Subcooling								
R-134a* R-1234yf* R-1234ze* R-401A* R-422B* R-422D* R-438A*	+40	5.7	7.9	14.2	22.6	37.0	50.5	84.4	143.4
	+30	4.6	6.4	11.5	18.3	30.0	40.8	68.2	116.0
	+20	3.7	5.1	9.2	14.7	24.0	32.7	54.6	92.8
	+10	2.9	4.1	7.3	11.6	19.0	25.9	43.3	73.6
	0	2.3	3.2	5.7	9.1	14.9	20.4	34.0	57.9
	-10	1.8	2.5	4.4	7.1	11.6	15.8	26.3	44.8
	-20	1.5	2.0	3.6	5.5	9.5	12.9	21.6	36.7
	-30	1.1	1.5	2.7	4.2	7.1	9.7	16.3	27.6
R-22* R-427A*	+40	8.8	12.3	22.1	33.6	57.6	78.5	131.1	222.8
	+30	7.3	10.2	18.4	27.9	47.8	65.2	108.9	185.1
	+20	6.0	8.4	15.1	23.0	39.4	53.7	89.7	152.6
	+10	4.9	6.9	12.4	18.8	32.2	43.9	73.3	124.7
	0	4.0	5.6	10.0	15.3	26.1	35.6	59.5	101.1
	-10	3.2	4.5	8.1	12.2	21.0	28.6	47.8	81.2
	-20	2.6	3.6	6.4	9.7	16.7	22.7	38.0	64.6
	-30	2.0	2.8	5.0	7.7	13.1	17.9	29.8	50.7
R-404A* R-407F* R-421A* R-422A* R-422C* R-427A*	+40	9.0	12.5	22.6	34.3	58.7	80.0	133.7	227.3
	+30	7.5	10.4	18.8	28.6	48.9	66.6	111.3	189.3
	+20	6.0	8.3	15.0	22.8	39.1	53.2	89.0	151.2
	+10	4.8	6.7	12.1	18.4	31.5	42.9	71.7	121.9
	0	3.9	5.4	9.7	14.7	25.2	34.3	57.3	97.4
	-10	3.1	4.2	7.6	11.6	19.9	27.1	45.3	77.0
	-20	2.4	3.3	6.0	9.1	15.6	21.2	35.5	60.3
	-30	1.8	2.6	4.6	7.0	12.0	16.4	27.4	46.6
R-410A* AZ-20*	+40	12.8	17.9	32.1	48.9	83.6	114.0	190.5	323.8
	+30	10.6	14.8	26.6	40.5	69.3	94.5	157.9	268.4
	+20	8.8	12.2	22.0	33.4	57.1	77.9	130.1	221.2
	+10	7.2	10.0	17.9	27.3	46.7	63.7	106.4	180.8
	0	5.8	8.1	14.5	22.1	37.8	51.6	86.2	146.5
	-10	4.7	6.5	11.7	17.8	30.4	41.5	69.3	117.8
	-20	3.7	5.2	9.3	14.1	24.2	33.0	55.1	93.7
	-30	2.9	4.1	7.3	11.1	19.0	26.0	43.4	73.7
R-507* R-402A* R-407A* R-407C*	+40	9.2	12.8	23.1	35.2	60.2	82.0	137.1	233.0
	+30	7.6	10.5	18.9	28.8	49.3	67.2	112.3	190.9
	+20	6.2	8.6	15.4	23.4	40.1	54.6	91.3	155.2
	+10	5.0	6.9	12.4	18.9	32.4	44.1	73.7	125.4
	0	4.0	5.5	9.9	15.1	25.9	35.3	59.0	100.2
	-10	3.1	4.4	7.9	12.0	20.5	28.0	46.7	79.4
	-20	2.5	3.4	6.2	9.4	16.1	21.9	36.6	62.3
	-30	1.9	2.7	4.8	7.3	12.5	17.0	28.4	48.3
-40	1.5	2.0	3.7	5.6	9.5	13.0	21.7	36.9	

* Approximate tonnage, see Sizing Charts on www.temprite.com for actual tonnage.

See www.temprite.com for a full list of refrigerants.

THE CONNECTIONS ON THE OIL SEPARATOR MUST BE THE SAME SIZE AS (OR LARGER THAN) THE DISCHARGE LINE SIZE.

920/920R Series Notes:

1. Suitable for all refrigerants including Ammonia (NH₃, R717) and Carbon Dioxide (CO₂, R744)
2. All products rated for subcritical CO₂ applications and R-410A application (maximum 650 PSI)
3. Tons = Capacity in evaporator (12,000 BTUH/Hr/Ton) based on +100°F Condensing Temperature, +10°F Superheat, 0°F Subcooling.
4. For applications other than reciprocating, screws or 2-stage compressors, please contact Temprite engineering at temprite@temprite.com.

For subcritical CO₂ applications, see page 21.

For Ammonia (NH₃), see page 18.

Temprite 920 & 920R Series: Capacities in kW

	Model	922 922R	923 923R	924 924R	925 925R	926 926R	927 927R	928 928R	930 930R
	Connection Size	5/8"	7/8"	1-1/8"	1-3/8"	1-5/8"	2-1/8"	2-5/8"	3-1/8"
Refrigerant	Temp °C	kW @ 37.8°C Condensing 5.6°C Superheat 0°C Subcooling							
R-134a* R-1234yf* R-1234ze* R-401A* R-422B* R-422D* R-438A*	4.4	20.0	27.8	50.0	79.6	130.3	177.6	296.7	504.3
	-1.1	16.2	22.5	40.5	64.4	105.4	143.6	240.0	408.0
	-6.7	12.9	18.0	32.4	51.5	84.3	114.9	192.0	326.4
	-12.2	10.3	14.3	25.7	40.9	66.8	91.1	152.2	258.7
	-17.8	8.1	11.2	20.2	32.1	52.6	71.7	119.8	203.6
	-23.3	6.2	8.7	15.6	24.9	40.7	55.4	92.6	157.4
	-28.9	5.1	7.1	12.8	19.5	33.3	45.5	75.9	129.1
	-34.4	3.9	5.4	9.6	14.7	25.1	34.2	57.2	97.2
-40	2.9	4.0	7.2	10.9	18.7	25.5	42.7	72.5	
R-22* R-427A*	4.4	31.1	43.2	77.8	118.3	202.4	275.9	461.0	783.7
	-1.1	25.8	35.9	64.6	98.3	168.2	229.2	383.0	651.2
	-6.7	21.3	29.6	53.2	81.0	138.6	188.9	315.6	536.6
	-12.2	17.4	24.2	43.5	66.2	113.2	154.4	257.9	438.5
	-17.8	14.1	19.6	35.3	53.6	91.8	125.2	209.1	355.5
	-23.3	11.3	15.7	28.3	43.1	73.7	100.5	167.9	285.5
	-28.9	9.0	12.5	22.5	34.3	58.7	80.0	133.6	227.1
	-34.4	7.1	9.8	17.7	26.9	46.1	62.8	104.9	178.3
-40	5.5	7.7	13.8	21.0	35.9	48.9	81.7	139.0	
R-404A* R-407F* R-421A* R-422A* R-422C* R-427A*	4.4	31.7	44.1	79.3	120.6	206.5	281.5	470.3	799.6
	-1.1	26.4	36.7	66.1	100.4	171.9	234.4	391.6	665.7
	-6.7	21.1	29.3	52.8	80.3	137.4	187.3	312.9	531.9
	-12.2	17.0	23.6	42.5	64.7	110.7	150.9	252.2	428.7
	-17.8	13.6	18.9	34.0	51.7	88.5	120.6	201.5	342.5
	-23.3	10.7	14.9	26.9	40.9	70.0	95.4	159.4	270.9
	-28.9	8.4	11.7	21.1	32.0	54.8	74.7	124.8	212.1
	-34.4	6.5	9.0	16.3	24.8	42.4	57.7	96.5	164.0
-40	5.0	6.9	12.4	18.9	32.4	44.1	73.7	125.3	
R-410A* AZ-20*	4.4	45.1	62.8	113.0	171.8	294.1	400.9	669.9	1138.8
	-1.1	37.4	52.1	93.7	142.4	243.8	332.4	555.3	944.0
	-6.7	30.8	42.9	77.2	117.4	200.9	273.9	457.7	778.0
	-12.2	25.2	35.1	63.1	96.0	164.3	223.9	374.1	636.0
	-17.8	20.4	28.4	51.1	77.8	133.1	181.4	303.2	515.4
	-23.3	16.4	22.8	41.1	62.5	107.0	145.9	243.7	414.3
	-28.9	13.1	18.2	32.7	49.7	85.1	116.1	193.9	329.7
	-34.4	10.3	14.3	25.7	39.1	67.0	91.3	152.6	259.3
-40	8.0	11.1	20.0	30.5	52.2	71.1	118.8	202.0	
R-507* R-402A* R-407A* R-407C*	4.4	32.5	45.2	81.3	123.6	211.6	288.5	482.0	819.4
	-1.1	26.6	37.0	66.6	101.3	173.4	236.4	394.9	671.4
	-6.7	21.6	30.1	54.2	82.4	141.0	192.2	321.1	545.8
	-12.2	17.5	24.3	43.8	66.5	113.9	155.2	259.4	440.9
	-17.8	14.0	19.4	35.0	53.2	91.1	124.1	207.4	352.5
	-23.3	11.1	15.4	27.7	42.1	72.1	98.3	164.3	279.3
	-28.9	8.7	12.1	21.7	33.0	56.6	77.1	128.8	219.0
	-34.4	6.7	9.4	16.9	25.7	43.9	59.8	100.0	170.0
-40	5.1	7.2	12.9	19.6	33.5	45.7	76.3	129.7	

* Approximate tonnage, see Sizing Charts on www.temprite.com for actual tonnage.

See www.temprite.com for a full list of refrigerants.

THE CONNECTIONS ON THE OIL SEPARATOR MUST BE THE SAME SIZE AS (OR LARGER THAN) THE DISCHARGE LINE SIZE.

920/920R Series Notes:

1. kW = Capacity based on +37.8°C Condensing temperature, +5.6°C Superheat, 0°C Subcooling
2. Suitable for all refrigerants including Ammonia (NH₃, R717) and Carbon Dioxide (CO₂, R744)
3. For applications other than reciprocating, screws or 2-stage compressors, please contact Temprite engineering at temprite@temprite.com.
For subcritical CO₂ applications, see page 21.
For Ammonia (NH₃), see page 18.

Temprite 920 & 920R Series: Natural Refrigerants, Tons and kW

Refrigerant	Model	922 922R	923 923R	924 924R	925 925R	926 926R	927 927R	928 928R	930 930R
	Connection Size	5/8"	7/8"	1-1/8"	1-3/8"	1-5/8"	2-1/8"	2-5/8"	3-1/8"
	Temp °F	Tons @ 100°F Condensing 10°F Superheat 0°F Subcooling							
R-717* NH ₃ *	+40	9.9	13.7	24.7	37.5	64.2	87.5	146.2	248.5
	+30	8.1	11.2	20.2	30.7	52.5	71.6	119.7	203.4
	+20	6.5	9.1	16.4	24.9	42.6	58.1	97.1	165.1
	+10	5.3	7.3	13.2	20.0	34.3	46.7	78.1	132.7
	0	4.2	5.8	10.5	15.9	27.3	37.2	62.1	105.6
	-10	3.3	4.6	8.2	12.5	21.4	29.2	48.9	83.0
	-20	2.6	3.6	6.4	9.7	16.7	22.7	38.0	64.6
	-30	2.1	2.9	5.3	8.0	13.7	18.7	31.2	53.1
	Temp °F	Tons @ 25°F Condensing 10°F Superheat 0°F Subcooling							
R-744* CO ₂ * Subcritical (650 PSI max)	+40	29.43	40.93	73.66	112.00	191.70	261.31	436.61	742.23
	+30	25.17	35.01	63.01	95.81	163.99	223.54	373.51	634.96
	+20	21.41	29.78	53.59	81.48	139.46	190.10	317.64	539.98
	+10	18.13	25.22	45.38	69.00	118.11	161.00	269.00	457.31
	0	15.27	21.24	38.23	58.13	99.49	135.62	226.60	385.22
	-10	12.79	17.78	32.00	48.66	83.29	113.53	189.69	322.47
	-20	10.63	14.78	26.60	40.45	69.23	94.37	157.68	268.05
	-30	8.77	12.20	21.96	33.39	57.16	77.91	130.18	221.31
	Temp °C	kW @ 37.8°C Condensing 5.6°C Superheat 0°C Subcooling							
R-717* NH ₃ *	4.4	34.6	48.2	86.7	131.9	225.7	307.7	514.1	873.9
	-1.1	28.4	39.5	71.0	108.0	184.8	251.9	420.9	715.5
	-6.7	23.0	32.0	57.6	87.6	150.0	204.4	341.5	580.6
	-12.2	18.5	25.7	46.3	70.4	120.5	164.3	274.5	466.7
	-17.8	14.7	20.5	36.8	56.0	95.9	130.7	218.4	371.3
	-23.3	11.6	16.1	29.0	44.1	75.4	102.8	171.8	292.1
	-28.9	9.0	12.5	22.5	34.3	58.6	79.9	133.5	227.0
	-34.4	7.4	10.3	18.5	28.2	48.2	65.7	109.8	186.6
	Temp °C	kW @ -3.88°C Condensing 5.6°C Superheat 0°C Subcooling							
R-744* CO ₂ * Subcritical (650 PSI max)	4.4	103.7	144.2	259.5	394.6	675.4	920.6	1538.2	2614.9
	-1.1	88.5	123.1	221.6	337.0	576.7	786.2	1313.6	2233.1
	-6.7	75.3	104.8	188.6	286.7	490.7	668.9	1117.7	1900.0
	-12.2	63.7	88.6	159.4	242.4	415.0	565.7	945.1	1606.7
	-17.8	53.7	74.7	134.4	204.4	349.9	477.0	796.9	1354.8
	-23.3	45.0	62.5	112.6	171.1	292.9	399.3	667.2	1134.2
	-28.9	37.4	52.0	93.6	142.3	243.5	332.0	554.7	943.0
	-34.4	30.8	42.9	77.2	117.4	200.9	273.9	457.6	777.9
	Temp °C	kW @ -3.88°C Condensing 5.6°C Superheat 0°C Subcooling							
R-744* CO ₂ * Subcritical (650 PSI max)	4.4	103.7	144.2	259.5	394.6	675.4	920.6	1538.2	2614.9
	-1.1	88.5	123.1	221.6	337.0	576.7	786.2	1313.6	2233.1
	-6.7	75.3	104.8	188.6	286.7	490.7	668.9	1117.7	1900.0
	-12.2	63.7	88.6	159.4	242.4	415.0	565.7	945.1	1606.7
	-17.8	53.7	74.7	134.4	204.4	349.9	477.0	796.9	1354.8
	-23.3	45.0	62.5	112.6	171.1	292.9	399.3	667.2	1134.2
	-28.9	37.4	52.0	93.6	142.3	243.5	332.0	554.7	943.0
	-34.4	30.8	42.9	77.2	117.4	200.9	273.9	457.6	777.9

* See www.temprite.com for a full list of refrigerants.

THE CONNECTIONS ON THE OIL SEPARATOR MUST BE THE SAME SIZE AS (OR LARGER THAN) THE DISCHARGE LINE SIZE.

920 and 920R Series for Natural Refrigerants, Tons and kW Notes:

1. Tons = Capacity in evaporator (12,000 BTUH/Hr/Ton), based on Condensing Temperature stated in the chart, 10°F Superheat, 0°F Subcooling.
2. kW = Capacity based on Condensing Temperature stated in the chart, 5.6°C Superheat, 0°C Subcooling.
3. For applications other than reciprocating compressors, (scroll, screw type, 2-stage) please contact Temprite engineering at temprite@temprite.com.
4. 920 and 920R separators are rated 44.8 bar (650 PSI).

Temprite 300 and 900 Series: Coalescent Oil Separators

Model	Connection Size	320**	340**	900**	901**	902**	903**	904**	905**
		3/8"	3/8"	3/8"	1/2"	5/8"	7/8"	1-1/8"	1-3/8"
Refrigerant	Temp °F	Tons @ 100°F Condensing 10°F Superheat 0°F Subcooling							
R-134a* R-1234yf* R-1234ze* R-401A* R-422B* R-422D* R-438A*	+40	1.6	3.2	2.1	4.0	5.7	7.9	14.2	22.6
	+30	1.3	2.6	1.7	3.2	4.6	6.4	11.5	18.3
	+20	1.0	2.0	1.4	2.6	3.7	5.1	9.2	14.7
	+10	0.8	1.6	1.1	2.0	2.9	4.1	7.3	11.6
	0	0.6	1.3	0.9	1.6	2.3	3.2	5.7	9.1
	-10	0.5	1.0	0.7	1.2	1.8	2.5	4.4	7.1
	-20	0.4	0.8	0.5	1.0	1.4	1.9	3.4	5.5
	-30	0.3	0.6	0.4	0.7	1.0	1.4	2.6	3.9
	-40	0.2	0.4	0.3	0.5	0.8	1.1	1.9	2.9
R-22* R-427A*	+40	2.5	4.9	3.3	6.1	8.8	12.3	22.1	33.6
	+30	2.0	4.1	2.7	5.1	7.3	10.2	18.4	27.9
	+20	1.7	3.4	2.3	4.2	6.0	8.4	15.1	23.0
	+10	1.4	2.7	1.8	3.4	4.9	6.9	12.4	18.8
	0	1.1	2.2	1.5	2.8	4.0	5.6	10.0	15.3
	-10	0.9	1.8	1.2	2.2	3.2	4.5	8.1	12.2
	-20	0.7	1.4	1.0	1.8	2.6	3.6	6.4	9.7
	-30	0.6	1.1	0.8	1.4	2.0	2.8	5.0	7.7
	-40	0.4	0.9	0.6	1.1	1.6	2.2	3.9	6.0
R-404A* R-407F* R-421A* R-422A* R-422C* R-427A*	+40	2.5	5.0	3.4	6.3	9.0	12.5	22.6	34.3
	+30	2.1	4.2	2.8	5.2	7.5	10.4	18.8	28.6
	+20	1.7	3.3	2.2	4.2	6.0	8.3	15.0	22.8
	+10	1.3	2.7	1.8	3.4	4.8	6.7	12.1	18.4
	0	1.1	2.1	1.4	2.7	3.9	5.4	9.7	14.7
	-10	0.8	1.7	1.1	2.1	3.1	4.2	7.6	11.6
	-20	0.7	1.3	0.9	1.7	2.4	3.3	6.0	9.1
	-30	0.5	1.0	0.7	1.3	1.8	2.6	4.6	7.0
	-40	0.4	0.8	0.5	1.0	1.4	2.0	3.5	5.4
R-410A* AZ-20*	+40	3.6	7.1	4.8	8.9	12.8	17.9	32.1	48.9
	+30	3.0	5.9	4.0	7.4	10.6	14.8	26.6	40.5
	+20	2.4	4.9	3.3	6.1	8.8	12.2	22.0	33.4
	+10	2.0	4.0	2.7	5.0	7.2	10.0	17.9	27.3
	0	1.6	3.2	2.2	4.0	5.8	8.1	14.5	22.1
	-10	1.3	2.6	1.7	3.2	4.7	6.5	11.7	17.8
	-20	1.0	2.1	1.4	2.6	3.7	5.2	9.3	14.1
	-30	0.8	1.6	1.1	2.0	2.9	4.1	7.3	11.1
	-40	0.6	1.3	0.9	1.6	2.3	3.2	5.7	8.7
R-507* R-402A* R-407A* R-407C*	+40	2.6	5.1	3.5	6.4	9.2	12.8	23.1	35.2
	+30	2.1	4.2	2.8	5.3	7.6	10.5	18.9	28.8
	+20	1.7	3.4	2.3	4.3	6.2	8.6	15.4	23.4
	+10	1.4	2.8	1.9	3.5	5.0	6.9	12.4	18.9
	0	1.1	2.2	1.5	2.8	4.0	5.5	9.9	15.1
	-10	0.9	1.8	1.2	2.2	3.1	4.4	7.9	12.0
	-20	0.7	1.4	0.9	1.7	2.5	3.4	6.2	9.4
	-30	0.5	1.1	0.7	1.3	1.9	2.7	4.8	7.3
	-40	0.4	0.8	0.5	1.0	1.5	2.0	3.7	5.6

* Approximate tonnage, see Sizing Charts on www.temprite.com for actual tonnage.
See www.temprite.com for a full list of refrigerants.

** For 300 and 900 Series Ultra Low Temperature Sizing Chart, see website www.temprite.com.

THE CONNECTIONS ON THE OIL SEPARATOR MUST BE THE SAME SIZE AS (OR LARGER THAN) THE DISCHARGE LINE SIZE.

300 and 900 Series Notes:

1. Tons = Capacity in evaporator (12,000 BTUH/Hr/Ton), based on +100°F Condensing Temperature, +10°F Superheat, 0°F Subcooling
2. For applications other than reciprocating, screws or 2-stage compressors, please contact Temprite engineering at temprite@temprite.com.

Temprite 500 and 600 Series: Conventional Oil Separators

	Model	600	501 601	502 602	503 603	504 604	505 605	506 606	507 607
	Connection Size	3/8"	1/2"	5/8"	7/8"	1-1/8"	1-3/8"	1-5/8"	2-1/8"
Refrigerant	Temp °F	Tons @ 100°F Condensing 10°F Superheat 0°F Subcooling							
R-134a* R-1234yf* R-1234ze* R-401A* R-422B* R-422D* R-438A*	+40	1.22	1.83	3.66	5.49	7.32	9.16	13.00	23.00
	+20	1.17	1.75	3.50	5.24	7.00	8.76	12.43	22.00
	+10	1.14	1.71	3.42	5.12	6.84	8.56	12.14	21.50
	0	1.12	1.67	3.34	4.99	6.68	8.35	11.85	21.00
	-10	1.09	1.63	3.26	4.87	6.52	8.15	11.56	20.50
	-20	1.06	1.59	3.18	4.74	6.36	7.95	11.28	20.00
	-30	1.04	1.55	3.10	4.62	6.20	7.75	10.99	19.50
	-40	1.01	1.51	3.02	4.49	6.04	7.55	10.70	19.00
R-22* R-427A*	+40	1.87	2.80	5.60	8.40	11.20	14.00	23.60	40.00
	+20	1.80	2.70	5.39	8.08	10.78	13.47	22.68	38.50
	+10	1.77	2.64	5.29	7.93	10.57	13.22	22.22	37.76
	0	1.73	2.59	5.18	7.77	10.36	12.95	21.75	37.00
	-10	1.69	2.54	5.08	7.61	10.15	12.69	21.29	36.26
	-20	1.66	2.49	4.97	7.46	9.94	12.43	20.82	35.50
	-30	1.62	2.43	4.86	7.30	9.73	12.16	20.37	34.76
	-40	1.59	2.38	4.76	7.14	9.52	11.90	19.90	34.00
R-404A* R-407F* R-421A* R-422A* R-422C* R-427A*	+40	1.87	2.80	5.60	8.40	11.20	14.00	23.60	40.00
	+20	1.80	2.70	5.39	8.08	10.78	13.47	22.68	38.50
	+10	1.77	2.64	5.29	7.93	10.57	13.22	22.22	37.76
	0	1.73	2.59	5.18	7.77	10.36	12.95	21.75	37.00
	-10	1.69	2.54	5.08	7.61	10.15	12.69	21.29	36.26
	-20	1.66	2.49	4.97	7.46	9.94	12.43	20.82	35.50
	-30	1.62	2.43	4.86	7.30	9.73	12.16	20.37	34.76
	-40	1.59	2.38	4.76	7.14	9.52	11.90	19.90	34.00
R-410A* AZ-20*	+40	2.60	4.00	7.70	11.60	15.50	19.30	32.60	55.20
	+20	2.50	3.85	7.42	11.18	14.90	18.58	31.32	53.12
	+10	2.45	3.78	7.29	10.96	14.60	18.22	30.69	52.10
	0	2.40	3.70	7.15	10.75	14.30	17.85	30.05	51.05
	-10	2.35	3.63	7.01	10.54	14.00	17.49	29.42	50.02
	-20	2.30	3.55	6.88	10.33	13.70	17.13	28.77	48.98
	-30	2.25	3.48	6.74	10.11	13.40	16.77	28.14	47.95
	-40	2.20	3.40	6.60	9.90	13.10	16.40	27.50	46.90
R-507* R-402A* R-407A* R-407C*	+40	1.87	2.80	5.60	8.40	11.20	14.00	23.60	40.00
	+20	1.80	2.70	5.39	8.08	10.78	13.47	22.68	38.50
	+10	1.77	2.64	5.29	7.93	10.57	13.22	22.22	37.76
	0	1.73	2.59	5.18	7.77	10.36	12.95	21.75	37.00
	-10	1.69	2.54	5.08	7.61	10.15	12.69	21.29	36.26
	-20	1.66	2.49	4.97	7.46	9.94	12.43	20.82	35.50
	-30	1.62	2.43	4.86	7.30	9.73	12.16	20.37	34.76
	-40	1.59	2.38	4.76	7.14	9.52	11.90	19.90	34.00

* Approximate tonnage, see Sizing Charts on www.temprite.com for actual tonnage.

See www.temprite.com for a full list of refrigerants.

THE CONNECTIONS ON THE OIL SEPARATOR MUST BE THE SAME SIZE AS (OR LARGER THAN) THE DISCHARGE LINE SIZE.

500 and 600 Series Notes:

1. Tons = Capacity in evaporator (12,000 BTUH/Hr/Ton), based on +100°F Condensing Temperature, +10°F Superheat, 0°F Subcooling
2. For applications other than reciprocating, screws or 2-stage compressors, please contact Temprite engineering at temprite@temprite.com.

Temprite 130 Series for Natural Refrigerants: Transcritical and Subcritical CO₂ (Tons and kW)

Model	131	133A	135A	137A	138A	139A
Connection Size	1/4"	1/2"	3/4"	1" or 1-1/4"*	1-1/2"	1-1/2" or 2" BW**
Temp. °F	Tons @ 100°F Gas Cooler Outlet 10°F Superheat 0°F Subcooling					
60	6.29	11.19	41.84	121.76	177.05	230.47
55	5.93	10.54	39.41	114.67	166.74	217.06
50	5.56	9.89	36.97	107.60	156.45	203.66
45	5.21	9.26	34.63	100.77	146.52	190.74
40	4.87s	8.66	32.38	94.24	137.03	178.38
35	4.54	8.08	30.21	87.91	127.82	166.40
30	4.23	7.52	28.12	81.82	118.97	154.87
25	3.94	7.01	26.19	76.21	110.82	144.26
20	3.65	6.48	24.24	70.55	102.58	133.54
15	3.37	6.00	22.44	65.30	94.95	123.60
10	3.12	5.54	20.73	60.32	87.71	114.17
5	2.88	5.12	19.13	55.66	80.93	105.36
0	2.65	4.71	17.60	51.22	74.48	96.95
Temp. °F	Tons @ 20°F Condensing 10°F Superheat 0°F Subcooling					
+20	7.03	12.45	46.67	135.87	197.84	257.48
+10	5.95	10.54	39.52	115.06	167.53	218.03
0	5.01	8.88	33.29	96.92	141.12	183.66
-10	4.20	7.43	27.87	81.13	118.13	153.74
-20	3.49	6.18	23.17	67.44	98.20	127.80
-30	2.88	5.10	19.13	55.69	81.08	105.53
-40	2.35	4.17	15.64	45.52	66.29	86.27
Temp. °C	kW @ 37.78°C Gas Cooler Outlet 5.6°C Superheat 0°C Subcooling					
15.56	22.13	39.36	147.15	428.23	622.67	810.58
12.78	20.84	37.07	138.59	403.30	586.42	763.38
10	19.56	34.78	130.04	378.42	550.24	716.28
7.222	18.31	32.57	121.78	354.40	515.31	670.82
4.444	17.13	30.46	113.89	331.44	481.93	627.36
1.667	15.98	28.42	106.24	309.18	449.55	585.22
-1.111	14.87	26.45	98.89	287.77	418.43	544.69
-3.889	13.85	24.64	92.11	268.04	389.74	507.36
-6.667	12.82	22.81	85.26	248.12	360.78	469.65
-9.444	11.87	21.11	78.92	229.66	333.93	434.71
-12.22	10.96	19.50	72.90	212.14	308.46	401.55
-15	10.12	17.99	67.27	195.76	284.64	370.53
-17.78	9.31	16.56	61.90	180.14	261.93	340.97
Temp. °C	kW @ -6.667°C Condensing 5.56°C Superheat 0°C Subcooling					
-6.7	24.71	43.77	164.15	477.85	695.80	905.54
-12.2	20.93	37.07	139.00	404.65	589.21	766.83
-17.8	17.63	31.22	117.09	340.85	496.32	645.93
-23.3	14.76	26.14	98.02	285.33	415.48	540.72
-28.9	12.27	21.73	81.48	237.19	345.37	449.48
-34.4	10.13	17.94	67.28	195.85	285.18	371.14
-40	8.28	14.67	55.00	160.11	233.14	303.41

* Customer specified: Butt Weld or Male Pipe Thread

** Butt Weld only.

THE CONNECTIONS ON THE OIL SEPARATOR MUST BE THE SAME SIZE AS (OR LARGER THAN) THE DISCHARGE LINE SIZE.

See page 18 for the 920 and 920R Series of components, suitable for subcritical applications up to 44.8 bar (650 PSI). The 920 and 920R Series are also ammonia compatible.

130 Series Notes:

1. Tons = Capacity in evaporator (12,000 BTUH/Hr/Ton), based on Condensing Temperature stated in chart, 10°F Superheat, 0°F Subcooling
2. kW = Capacity based on Condensing Temperature stated in chart, 5.56°C Superheat, 0°C Subcooling.
3. For applications other than reciprocating compressors (scroll, screw type, 2-stage), please contact Temprite engineering at temprite@temprite.com.

Quick Reference Chart

Model	Connection Size A	R-134a MP 39		R-22		R-404A HP-62, HP-80		R-410A		R-507		R-717		R-744 Subcritical		R-744 Transcritical	
		+40 Tons	-20 Tons	+40 Tons	-40 Tons	+40 Tons	-40 Tons	+40 Tons	-40 Tons	+40 Tons	-40 Tons	+40 Tons	-40 Tons	+20 Tons	-40 Tons	+60 Tons	0 Tons
131	1/4"													7.03	2.35	6.29	2.65
133A	1/2"													12.45	4.17	11.19	4.71
135A	3/4"													46.67	15.64	41.84	17.6
137A	1" or 1-1/4"													135.87	45.52	121.76	51.22
138A	1-1/2"													197.84	66.29	177.05	74.48
139A	1-1/2" or 2"													257.48	86.27	230.47	96.95
320*	3/8" ODS	1.6	0.4	2.5	0.4	2.5	0.4	3.6	0.6	2.6	0.4						
321*	1/8" FPT	1.6	0.4	2.5	0.4	2.5	0.4	3.6	1.3	2.6	0.4						
322*	1/4" SAE	1.6	0.4	2.5	0.4	2.5	0.4	3.6	0.6	2.6	0.4						
340*	3/8" ODS	3.2	0.8	4.9	0.9	5.0	0.8	7.1	1.3	5.1	0.8						
341*	1/8" FPT	3.2	0.8	4.9	0.9	5.0	0.8	7.1	1.3	5.1	0.8						
342*	1/4" SAE	3.2	0.8	4.9	0.9	5.0	0.8	7.1	1.3	5.1	0.8						
343*	3/8" SAE	3.2	0.8	4.9	0.9	5.0	0.8	7.1	1.3	5.1	0.8						
900*	3/8" ODS	2.1	0.5	3.3	0.6	3.4	0.5	4.8	0.9	3.5	0.5						
900-1*	3/8" ODS	2.1	0.5	3.3	0.6	3.4	0.5	4.8	0.9	3.5	0.5						
901*	1/2" ODS	4.0	1.0	6.1	1.1	6.3	1.0	8.9	1.6	6.4	1.0						
902*	5/8" ODS	5.7	1.4	8.8	1.6	9.0	1.4	12.8	2.3	9.2	1.5						
903*	7/8" ODS	7.9	1.9	12.3	2.2	12.5	2.0	17.9	3.2	12.8	2.0						
904*	1-1/8" ODS	14.2	3.4	22.1	3.9	22.6	3.5	32.1	5.7	23.1	3.7						
905*	1-3/8" ODS	22.6	5.5	33.6	6.0	34.3	5.4	48.9	8.7	35.2	5.6						

Model	Connection Size A	R-134a MP 39		R-22		R-404A HP-62, HP-80		R-410A		R-507		R-717		R-744		R-744 Subcritical	
		+40 Tons	-20 Tons	+40 Tons	-40 Tons	+40 Tons	-40 Tons	+40 Tons	-40 Tons	+40 Tons	-40 Tons	+40 Tons	-40 Tons	+40 Tons	-40 Tons	+50 Tons	-40 Tons
922/R	5/8" ODS	5.7	1.4	8.8	1.6	9.0	1.4	12.8	2.3	9.2	1.5	9.9	1.5	29.4	7.2	36.7	7.4
923/R	7/8" ODS	7.9	1.9	12.3	2.2	12.5	2.0	17.9	3.2	12.8	2.0	13.7	2.1	40.3	10.0	51.0	10.2
924/R	1-1/8" ODS	14.2	3.4	22.1	3.9	22.6	3.5	32.1	5.7	23.1	3.7	24.7	3.7	73.7	18.0	91.9	18.4
925/R	1-3/8" ODS	22.6	5.5	33.6	6.0	34.3	5.4	48.9	8.7	35.2	5.6	37.5	5.7	112.0	27.3	139.7	28
926/R	1-5/8" ODS	37.0	8.9	57.6	10.2	58.7	9.2	83.6	14.8	60.2	9.5	64.2	9.7	191.7	46.7	239.1	47.9
927/R	2-1/8" ODS	50.5	12.2	78.5	13.9	80.0	12.5	114.0	20.2	82.0	13.0	87.5	13.2	261.3	63.7	325.9	65.3
928/R	2-5/8" ODS	84.4	20.3	131.1	23.2	133.7	21.0	190.5	33.8	137.1	21.7	146.2	22.0	436.6	106.4	544.5	109.2
930/R	3-1/8" ODS	143.4	34.6	222.8	39.5	227.3	35.6	323.8	57.4	233.0	36.9	248.5	37.5	742.2	180.9	925.6	185.6
501	1/2" ODS	1.8	1.6	2.8	2.4	2.8	2.4	4.0	3.4	2.8	2.4						
502	5/8" ODS	3.7	3.2	5.6	4.8	5.6	4.8	7.7	6.6	5.6	4.8						
503	7/8" ODS	5.5	4.7	8.4	7.1	8.4	7.1	11.6	9.9	8.4	7.1						
504	1-1/8" ODS	7.3	6.4	11.2	9.5	11.2	9.5	15.5	13.1	11.2	9.5						
505	1-3/8" ODS	9.2	8.0	14.0	11.9	14.0	11.9	19.3	16.4	14.0	11.9						
506	1-5/8" ODS	13.0	11.3	23.6	19.9	23.6	19.9	32.6	27.5	23.6	19.9	26.7	24.6				
507	2-1/8" ODS	23.0	20.0	40.0	34.0	40.0	34.0	55.2	46.9	40.0	34.0	45.2	41.7				
600	3/8" ODS	1.2	1.1	1.9	1.6	1.9	1.6	2.6	2.2	1.9	1.6						
601	1/2" ODS	1.8	1.6	2.8	2.4	2.8	2.4	4.0	3.4	2.8	2.4						
602	5/8" ODS	3.7	3.2	5.6	4.8	5.6	4.8	7.7	6.6	5.6	4.8						
603	7/8" ODS	5.5	4.7	8.4	7.1	8.4	7.1	11.6	9.9	8.4	7.1						
604	1-1/8" ODS	7.3	6.4	11.2	9.5	11.2	9.5	15.5	13.1	11.2	9.5						
605	1-3/8" ODS	9.2	8.0	14.0	11.9	14.0	11.9	19.3	16.4	14.0	11.9						
606	1-5/8" ODS	13.0	11.3	23.6	19.9	23.6	19.9	32.6	27.5	23.6	19.9	26.7	24.6				
607	2-1/8" ODS	23.0	20.0	40.0	34.0	40.0	34.0	55.2	46.9	40.0	34.0	45.2	41.7				

* For 300 and 900 Series Ultra Low Temperatures, go to Sizing Charts on www.temprite.com.

See www.temprite.com for a full list of refrigerants.

THE CONNECTIONS ON THE OIL SEPARATOR MUST BE THE SAME SIZE AS (OR LARGER THAN) THE DISCHARGE LINE SIZE.

Notes:

1. Tons = Capacity in evaporator (12,000 BTUH/Hr/Ton), based on 100°F Condensing Temperature, +10°F Superheat, 0°F Subcooling, except for CO₂.
2. CO₂ Transcritical Tons = Capacity in evaporator (12,000 BTUH/Hr/Ton) based on 100°F Gas Cooler Outlet Temperature, +10°F Superheat, 0°F Subcooling.
3. CO₂ Subcritical Tons = Capacity in evaporator (12,000 BTUH/Hr/Ton) based on 20°F Condensing Temperature, +10°F Superheat, 0°F Subcooling.
4. For applications other than reciprocating compressors (scroll, screw type, 2-stage), please contact Temprite engineering at temprite@temprite.com.



Photos are not to scale

Oil Level Controls: Mechanical

Maximum Working Pressure: 44.8 bar (650 PSI)

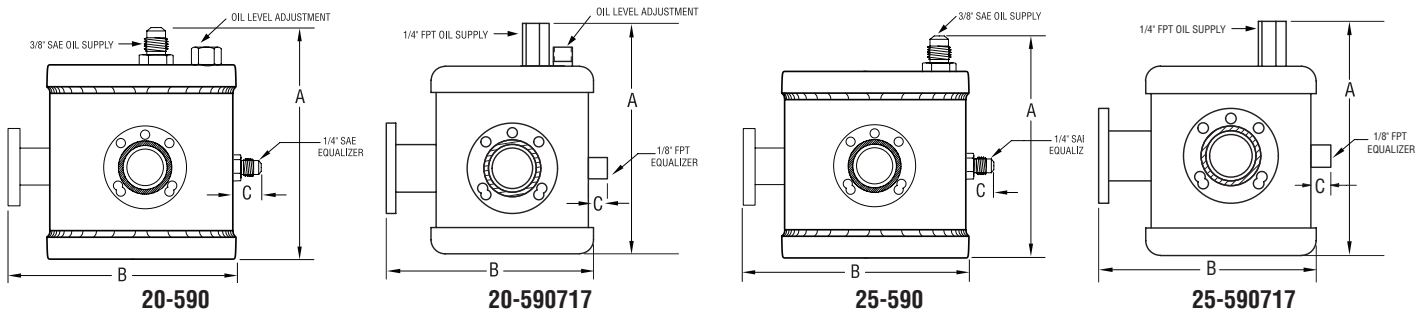

Part #	Model #	Operating Range	A Dim.	B Dim.	C Dim.	Refrigerants
020590000	20-590	Adjustable 5-90 PSI, .35-6.2 bar	5-5/8" 143 mm	5-1/2" 140 mm	3/4" 19 mm	All*
020590717	20-590717	Adjustable 5-90 PSI, .35-6.2 bar	6-1/16" 154 mm	5-7/16" 139 mm	1/2" 13 mm	Ammonia (NH ₃) and all refrigerants except transcritical CO ₂
025590000	25-590	Non-adjustable 5-90 PSI, .35-6.2 bar	5-3/8" 136 mm	5-3/8" 136 mm	3/4" 19 mm	All*
025590717	25-590717	Adjustable 5-90 PSI, .35-6.2 bar	5-7/8" 149 mm	5-7/16" 138 mm	1/2" 13 mm	Ammonia (NH ₃) and all refrigerants except transcritical CO ₂

* Compatible with all refrigerants except ammonia (NH₃).

Temprite® Oil Reservoirs

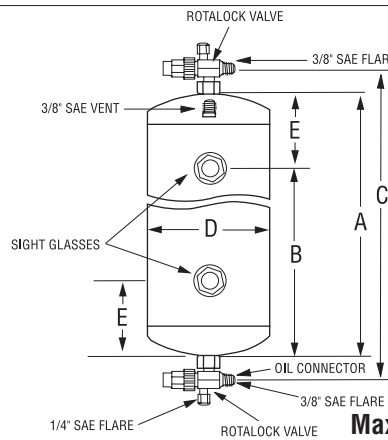

Models 47058, 47080 & 47115

Maximum Working Pressure: 44.8 bar (650 PSI)

Part #	Model #	Oil Conn. Size	A Capacity	B Capacity	47058, 47080 & 47115 Dim.	C Dim.	D Dim.	E Dim.	Sight Glasses	
90010000	47058	3/8" SAE*	1.6 Gal. 196 oz. 5.8 Liters	1.2 Gal. 146 oz. 4.318 Liters	13-1/2" 343 mm	9-3/4" 248 mm	16-1/2" 413 mm	6" 152 mm	3-3/4" 95 mm	2
90020000	47080	3/8" SAE*	2.1 Gal. 270 oz. 8 Liters	1.7 Gal. 220 oz. 6.506 Liters	19-1/4" 489 mm	15-1/2" 394 mm	22-1/4" 559 mm	6" 152 mm	3-3/4" 95 mm	2
90030000	47115	3/8" SAE*	3 Gal. 388 oz. 11.5 Liters	2.6 Gal. 338 oz. 9.996 Liters	27-1/4" 692 mm	23-1/2" 596 mm	30-1/4" 762 mm	6" 152 mm	3-3/4" 95 mm	2

* SAE = 45° Flare Connection,

Temprite® Oil Reservoirs

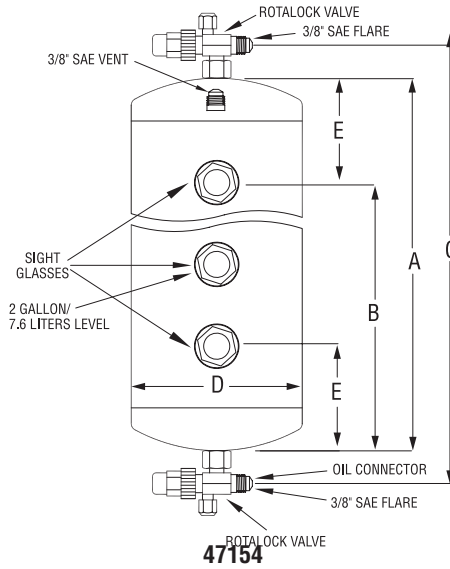

Model 47154

Maximum Working Pressure: 44.8 bar (650 PSI)

Part #	Model #	Oil Conn. Size	A Capacity	B Capacity	A Dim.	B Dim.	C Dim.	D Dim.	E Dim.	Sight Glasses
90040000	47154	3/8" SAE**	4 Gal. 512 oz. 15 Liters	3.5 Gal. 448 oz. 13.25 Liters	37" 940 mm	31-7/8" 810 mm	40" 1016 mm	6" 152 mm	5-1/8" 130 mm"	3

Models RES7 and RES17 Oil Reservoirs for Transcritical CO₂

Compatible with traditional refrigerants, new blends and natural refrigerants.*

* Traditional refrigerants such as R-22 and blends like R-404a; new blends such as R-427a and R-448a; and natural refrigerants such as ammonia (NH₃) and CO₂.

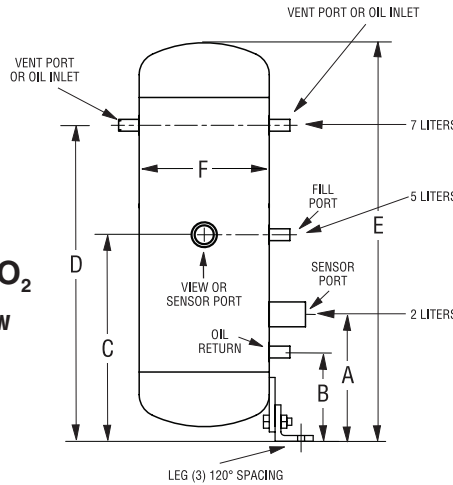

RES7 and RES17

Maximum Working Pressure: 140 bar (2030 PSI)

Part #	Model #	Vent Port/ Oil Inlet/ Oil Return	View/ Sensor Port Conn.	A Dim.	B Dim.	C Dim.	D Dim.	E Dim.	F Dim.
				Sensor Port	Oil Return	View/ Fill Port	Vent Port/ Oil Inlet	Overall Height	Dia.
013700000	RES7	1/4" FPT**	3/4" FPT**	216 mm 8-1/2" 2 Liters	143 mm 5-5/8"	448 mm 17-5/8" 5 Liters	603 mm 23-3/4" 7 Liters	711 mm 28"	141 mm 5-9/16"
013900017	RES17*	1/4" FPT**	3/4" FPT**	289 mm 11-3/8" 7 Liters	152 mm 6"	424 mm 16-11/16" 11 Liters	606 mm 23-7/8" 16.5 Liters	735 mm 29"	219 mm 8-5/8"

* 17-Liter reservoirs and larger installed in Canada must be ASME vessels with a CRN number. Order a model RES17 ASME.

** FPT = Female Pipe Thread, SAE = 45° Flare Connection

Oil Return Floats

Compatible with all refrigerants including ammonia (NH₃).

Maximum Working Pressure: 44.8 bar (650 PSI)

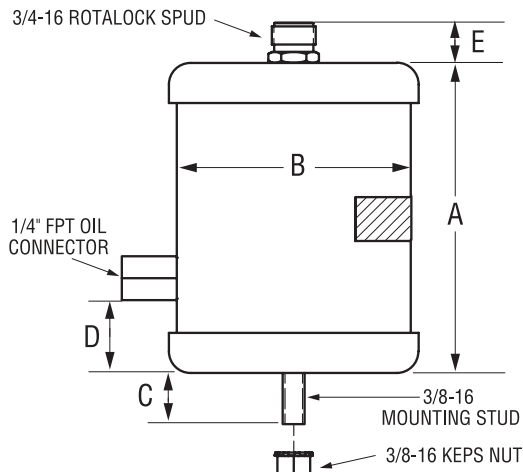

3358717

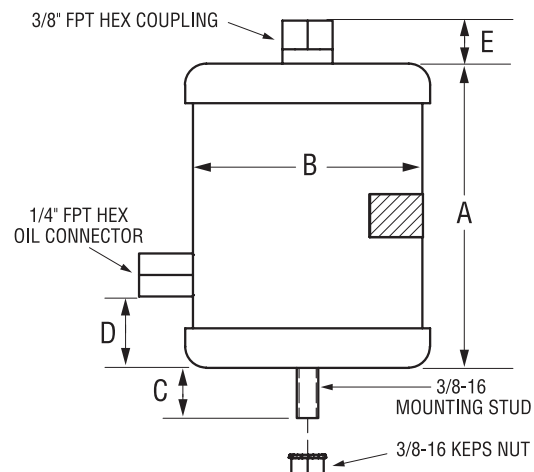

3458717

Models 3358717, 3458717: Hermetic

Part #	Model #	Oil Outlet	Top Connection Size	A Dim.	B Dim.	C Dim.	D Dim.	E Dim.	Refrigerant
003358717	3358	1/4" FPT*	3/4-16 Rotalock Spud	5-5/16" 135 mm	4" 102 mm	7/8" 22 mm	1-5/8" 41 mm	11/16" 17 mm	All
003458717	3458	1/4" FPT*	3/8" FPT* Hex Coupling	5-5/16" 135 mm	4" 102 mm	7/8" 22 mm	1-5/8" 41 mm	3/4" 19 mm	All

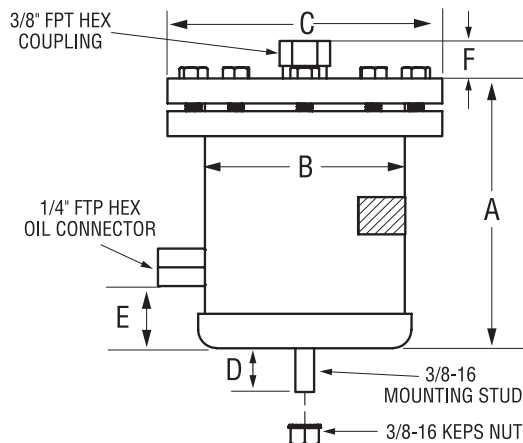

3658717

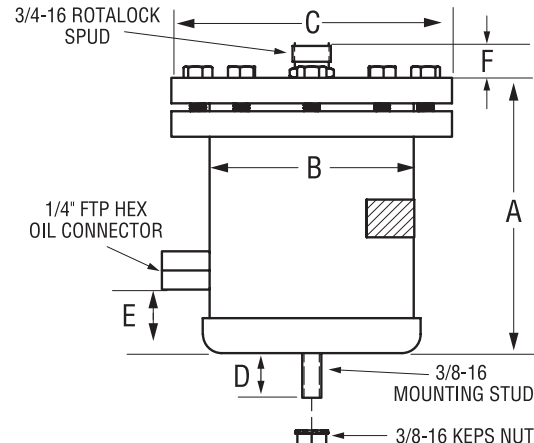

3758717

Models 3658717, 3758717: Accessible

Part #	Model #	Oil Outlet	Top Connection Size	A Dim.	B Dim.	C Dim.	D Dim.	E Dim.	F Dim.	Refrigerant
003658717	3658	1/4" FPT*	3/8" FPT* Coupling	5-3/8" 137 mm	4" 102 mm	5-1/2" 140 mm	7/8" 22 mm	1-5/8" 41 mm	3/4" 19 mm	All
003758717	3758	1/4" FPT*	3/4-16 Rotalock Spud	5-3/8" 137 mm	4" 102 mm	5-1/2" 140 mm	7/8" 22 mm	1-5/8" 41 mm	11/16" 17 mm	All

* FPT = Female Pipe Thread

Valves

- Oil moving from the oil separator to the oil reservoir or oil level controls is at a higher discharge pressure. This pressure must be reduced to a pressure slightly higher than the compressor crankcase.
- To maintain proper oil return, each of the oil system components must be selected according to the requirements of the overall oil control system.



High Pressure System: A-7 or Y1236C Valve

- If your system has an oil separator with a built-in oil reservoir, you will need one of two models, depending on your system: either an A-7, a constant-outlet pressure valve, or a Y1236C, a variable-outlet pressure valve.*

* The majority of Temprite 920R Series users monitor the oil back to the oil level control via the A-7 pressure-reducing valve set to the desired pressure.

- The Y1236C is designed for high-pressure oil return systems, or other situations where a differential pressure regulator is required.

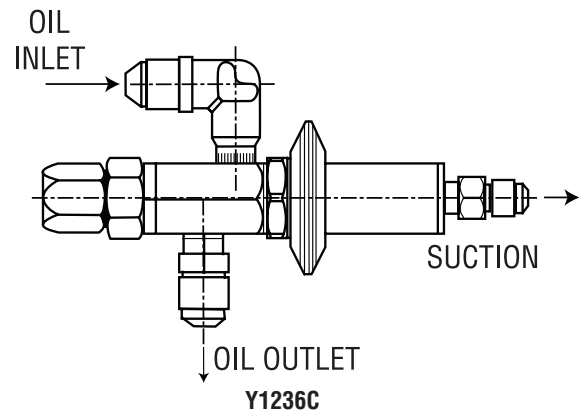
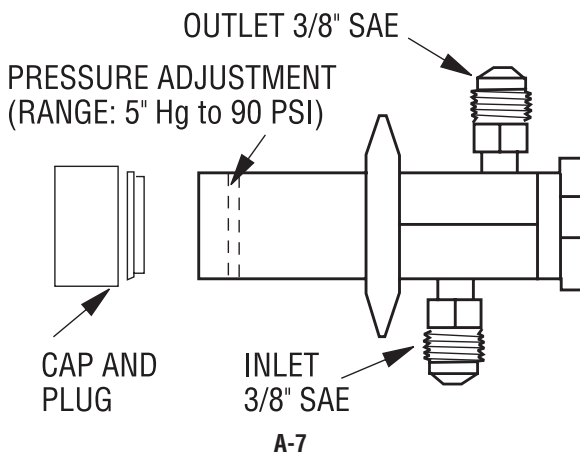

Notes:

If you are using a split-suction header, i.e., +20°F, -20°F, you will need two (2) A-7 valves or two (2) Y1236 valves, one per suction group.

A TraxOil electronic oil level control does not require a pressure-reducing valve.

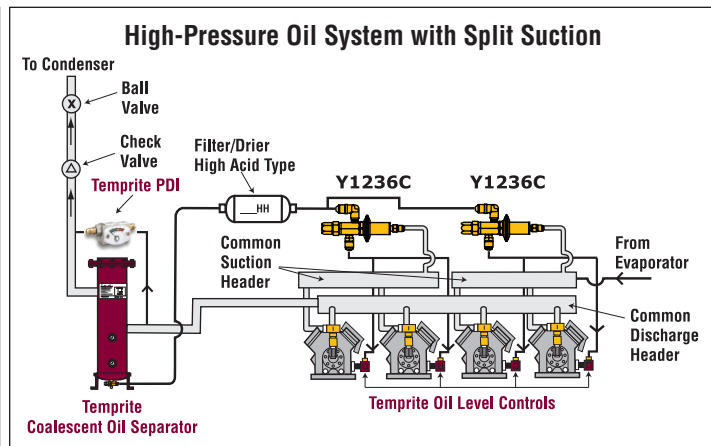
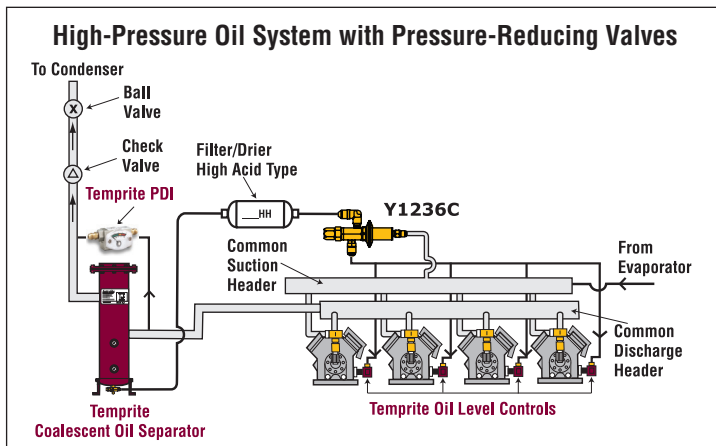

Valves

Low Pressure System: OCV-20 Valve

If your system has an oil separator with an external reservoir, you need the OCV-20. The Oil Differential Check Valve-20 (OCV-20) relieves pressure from the reservoir to the suction header, to maintain a higher pressure in the reservoir at a pre-set level above the suction pressure.

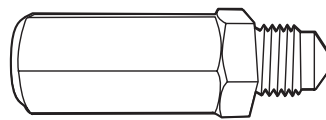

OCV-20

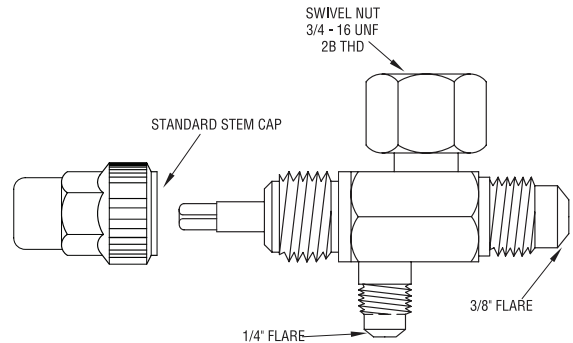

Rotalock Valve

Part #	Model #	Operating Range	Max. Working Press.	Connection Size	Refrigerant
67030000	Rotalock Valve	N/A	650 PSI	3/4"-16UNF and 3/8" SAE*, 1/4" SAE* Service*	All**
67035200	Rotalock Valve	N/A	650 PSI	3/4" - 16 UNF* 1/4" FPT*	All plus Ammonia (NH ₃)
67050000	A-7	5" Hg-90 PSI	400 PSI	3/8" SAE*	All**
67071020	OCV-20	N/A	650 PSI	3/8" SAE* M&F*	All**
67071236	Y1236C	10 to 25 PSI	650 PSI	3/8" SAE*	All**

* SAE = 45° Flare Connection, FPT = Female Pipe Thread, M&F = Male and Female

** Except Ammonia (NH₃)

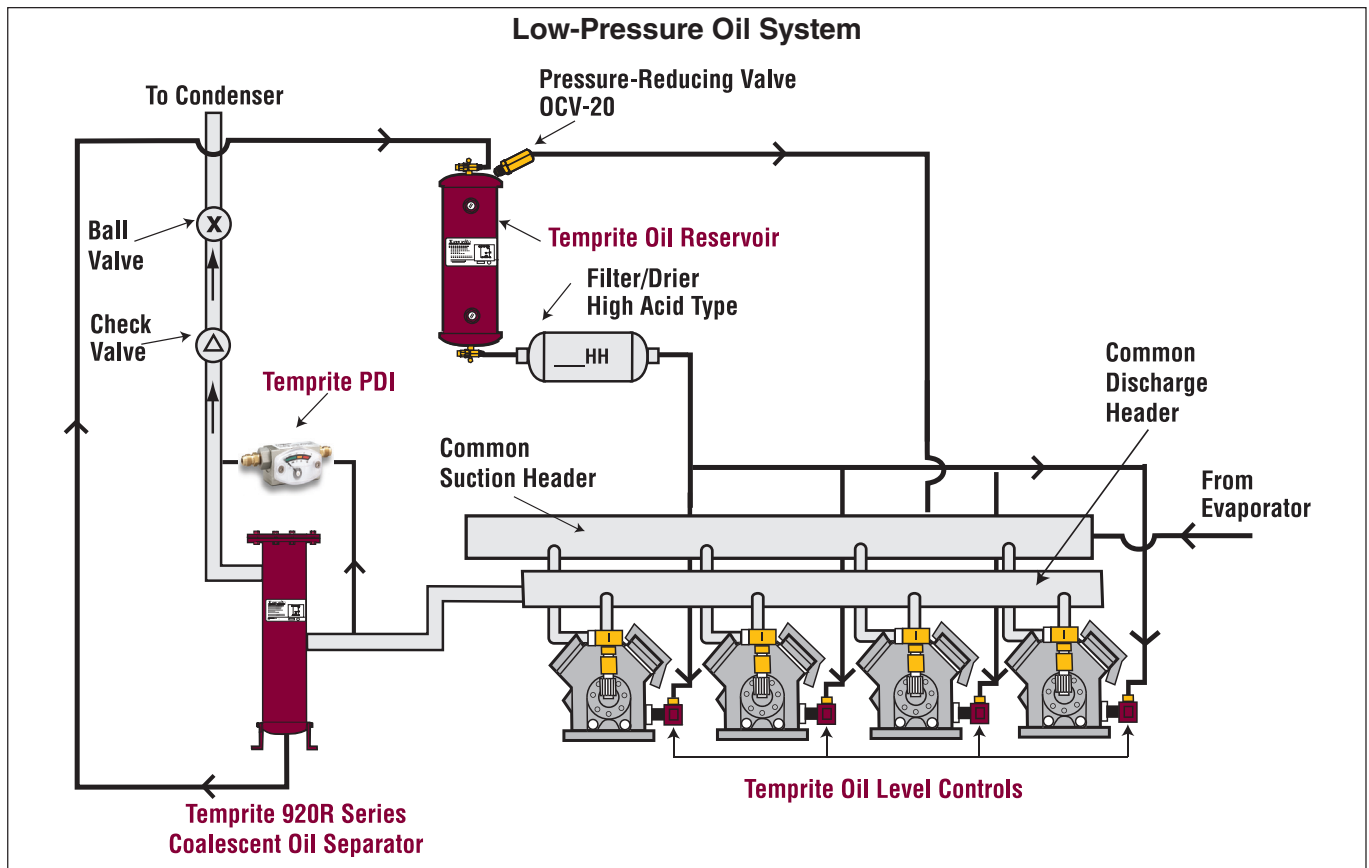

TraxOil TR4 & TR5 Electronic Oil Level Controls



TraxOil products are approved by the major compressor manufacturers

All versions use a hall sensor to measure the oil level. A magnetic float changes its position according to the oil level. The hall sensor converts these magnetic field changes into an equivalent signal, which is used by the internal electronic to show the actual oil level with LEDs and activate the integrated solenoid valve to feed missing oil directly into the compressor sump. For application in refrigeration systems according to EN 378.

Notes:

- TR4 is developed for all traditional refrigerants and subcritical CO₂.
- TR5 is specially adapted to the requirements of transcritical CO₂ systems and must be used with dedicated types of CO₂ adapters.
- An A-7 or Y11236C valve is not required with a TraxOil oil level control.

Key Features

- Digital processor with SMT components
- Alarm relay can switch 24 to 240 VAC
- CE approved, EMC emissions and immunity
- UL approved
- Meets European RoHS and WEEE directives
- All timing functions are in true time
- IP65 rated for dust and water
- Waterproof cables with no wiring at TraxOil unit
- No orifice restrictor
- Danfoss coil and enclosing tube complete with internal solenoid seat
- Tamperproof, cannot be adjusted in field
- Set point levels use true levels with no timing overruns
- Easily removable inlet fitting with built-in filter screen

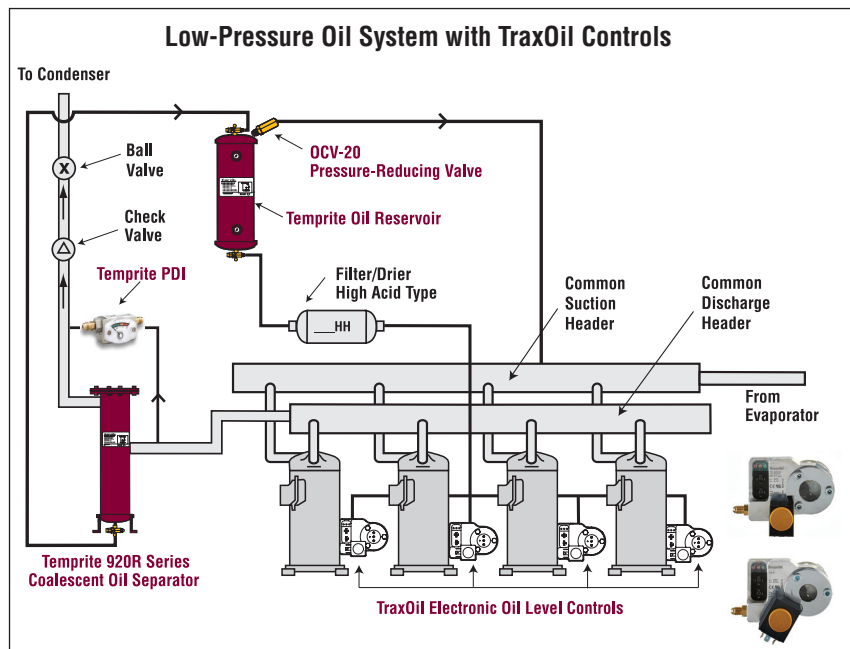
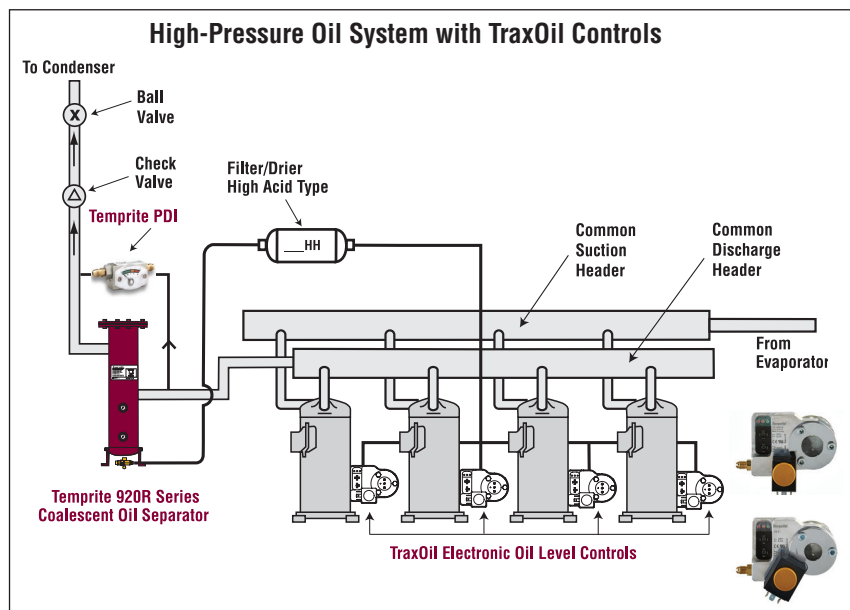

TraxOil TR4 & TR5 Electronic Oil Level Controls

Operation

TR4 and TR5 are fully level controlled. The sight glass of each device is divided into three operational zones. When the level reaches the yellow zone (Yellow) the TR starts filling after a time delay of 10 sec. A further level drop to the red zone (Red) will switch the alarm relay after a time delay of 20 sec / 120 sec.

The current status is indicated with the 3 LEDs according to the following table:

Operating Condition / Status	Function	Contact Position	LED
Supply power is off or normal oil level (<50%)	OK	BK-BU close BK-BN open	● Green
Oil Level (close 40%)	Injection		● Green ● Yellow
Oil Level < 40%	Injection		● Yellow
Oil level too low < 30%	Alarm + Injection	BK-BU open BK-BN close	● Red ● Yellow

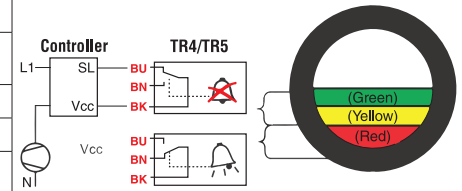

Technical Data

	TR4	TR5
Max working pressure PS	870 Psig	1885 Psig (inlet), 1450 Psig (outlet)
Solenoid coils/Supply voltage	ASC3-24VAC: 24VAC±10%, 50/60 Hz, 17VA	ASC3-24V-60Hz: 24VAC±10%, 60 Hz, 35VA
Solenoid valve max MOPD at 24VAC -0%	435 Psig (50 Hz, ASC3-) 290 Psig (60 Hz, ASC3-)	1450 Psig (ASC3-24V-60Hz) Flow Rate and Differential Pressure between inlet and outlet TR5 (Oil type Reniso C85E, oil temperature 54°C)
		<div style="display: flex; justify-content: space-around;"> <div style="text-align: center;"> <p>0 Supply Voltage 24V -0% (60Hz)</p> </div> <div style="text-align: center;"> <p>Supply Voltage 24V -10% (60 Hz)</p> </div> </div>
Current	0.7 A	
Alarm contact rating	3A/230 VAC	
Alarm switch	SPDT	
Time delay filling	10 sec.	
Time delay alarm	20 sec.	

Visit www.temprite.com for Compressor Compatibility Listing and additional technical information.

TraxOil Electronic Oil Level Controls

Maximum Working Pressure: 43 bar (634 PSI)

Part Number	Model
83004201	TR4201
83004202	TR4202
83004203	TR4203
83005203	TR5203
83005215	TR5215

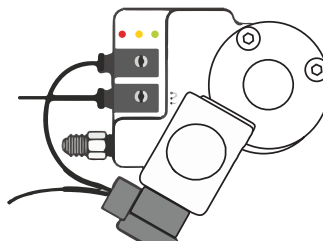

Model TR5

TraxOil OilWatches

Maximum Working Pressure: 43 bar (624 PSI)

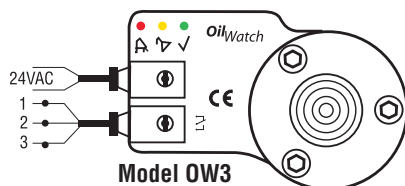

Part Number	Model
83001001	OW3-01
83001002	OW3-02

The OW3 OilWatch system is a self-contained system that provides oil level monitoring, alarm functionality and compressor shutdown, and uses a Hall sensor to measure the oil level. A magnetic float changes its position according to the oil level. The Hall sensor converts these magnetic field changes into an equivalent signal. The electronic controller converts that signal into the LED display that shows oil level. If the oil level drops into the red zone, the OW3 generates an alarm signal and the alarm contact changes into alarm state. The latter may be used to shut down the compressor. If the oil level comes back to normal, the alarm is reset.

Liquid Receivers

Liquid Receivers

Temprite adds to its line of oil management products with new Liquid Receivers for small- to large-refrigerant systems. A Liquid Receiver is a storage tank for holding liquid refrigerant and is located after the condenser in a refrigeration system. A Liquid Receiver is an important part of any system because it ensures liquid refrigerant is entering the expansion device. Each Receiver has Inlet and Outlet connections and a threaded port for installation of an over-pressure safety relief device.

Temprite Liquid Receivers accommodate all refrigerants: carbon dioxide (CO₂); hydrocarbons (HCs), including ethane, isobutane, and propane; and ammonia (NH₃).

The smallest unit, Model VR6-12, has a bottom mounting stud. Fixed mounting feet are installed on Models VR8-16 through VR18-60. Models VR14-36 through VR18-60 also have lifting lugs on their top domes. Horizontal receivers are also available. All receivers are welded and have all-steel components.

Custom Liquid Receivers and options such as sight glasses and sensors are available for all models.

For more information, contact Temprite.

Maximum Working Pressure: 44.8 bar (650 PSI) VR6-12; All other sizes: 41.4 bar (600 PSI)				
Model	Pump Down Capacity			
	R22	R410A	R134A	R404A
VR6-12	4.9 kg 10.8 lb	4.3 kg 9.5 lb	5.0 kg 11.0 lb	4.3 kg 9.4 lb
VR8-16	11.7 kg 25.9 lb	10.4 kg 22.8 lb	11.9 kg 26.3 lb	10.3 kg 22.6 lb
VR10-20	23.7 kg 52.3 lb	20.9 kg 46.1 lb	24.0 kg 53.0 lb	20.6 kg 45.5 lb
VR12-24	41.2 kg 90.8 lb	36.3 kg 80.0 lb	41.8 kg 92.2 lb	35.9 kg 79.1 lb
VR14-36	75.3 kg 166.1 lb	66.4 kg 146.4 lb	76.5 kg 168.6 lb	65.6 kg 144.6 lb
VR16-48	141.1 kg 311.0 lb	124.3 kg 274.1 lb	143.2 kg 315.6 lb	122.8 kg 270.7 lb
VR18-60	217.2 kg 478.8 lb	191.4 kg 421.9 lb	220.4 kg 485.8 lb	189.1 kg 416.8 lb

All pump down capacities are calculated using 90% of receiver volume at 90° F.

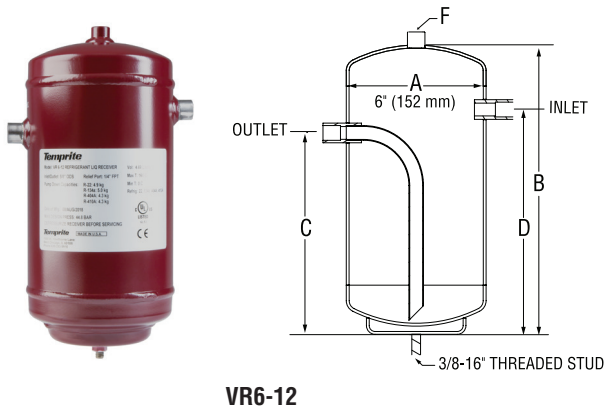

VR6-12

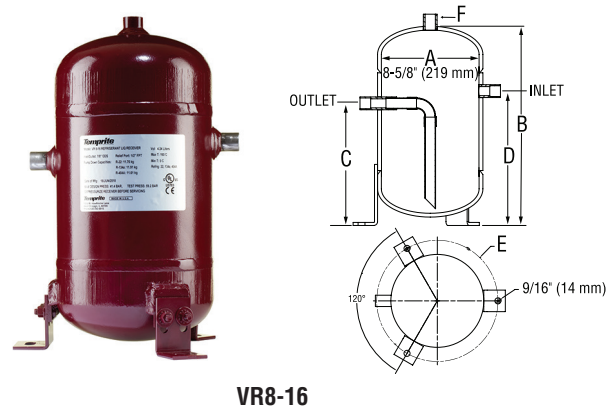

VR8-16

Part #	Model	Inlet/Outlet	A Dim.	B Dim.	C Dim.	D Dim.	E Dim.	F Dim.	Internal Volume	Code of Construction
			Dia.	Height	Outlet Loc.	Inlet Loc.	Mounting Bolt Center	FPT*		
95106120	VR6-12	5/8" ODS*	152 mm 6"	313 mm 12-5/16"	219 mm 8-5/8"	244 mm 9-5/8"	N/A	1/4"	4.67 Liter 1.24 gal	UL
95108160	VR8-16	7/8" ODS*	219 mm 8-5/8"	414 mm 16-5/16"	254 mm 10"	279 mm 11"	284 mm 11-3/16"	1/2"	11.24 Liter 2.97 gal	ASME

* FPT = Female Pipe Thread, ODS = Outside Diameter Solder

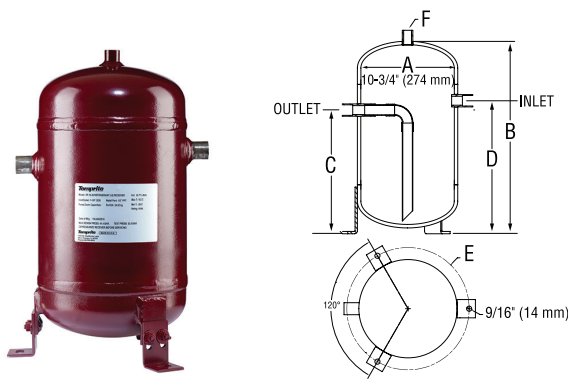

VR10-20

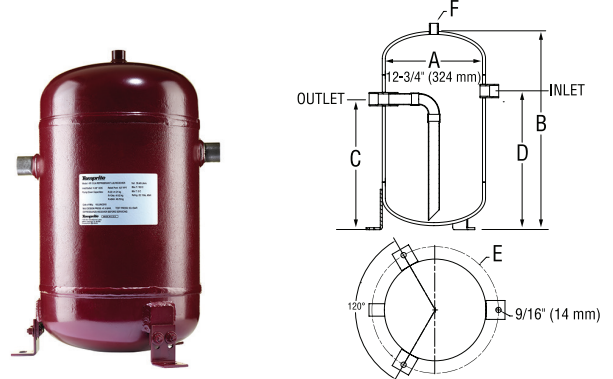

VR12-24

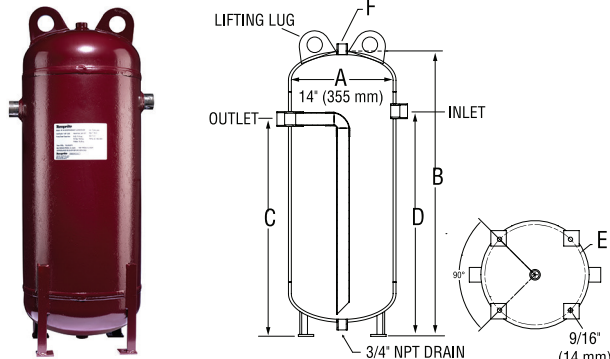

VR14-36

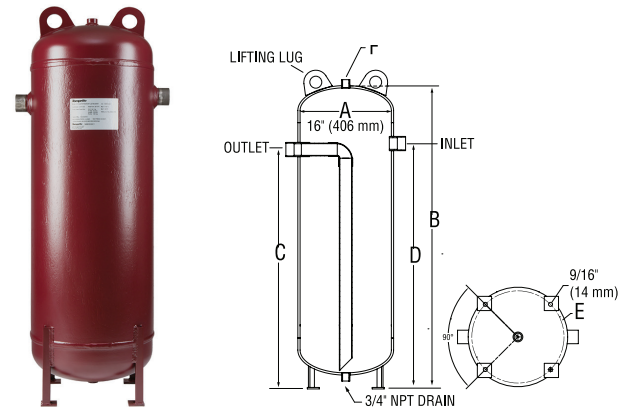

VR16-48

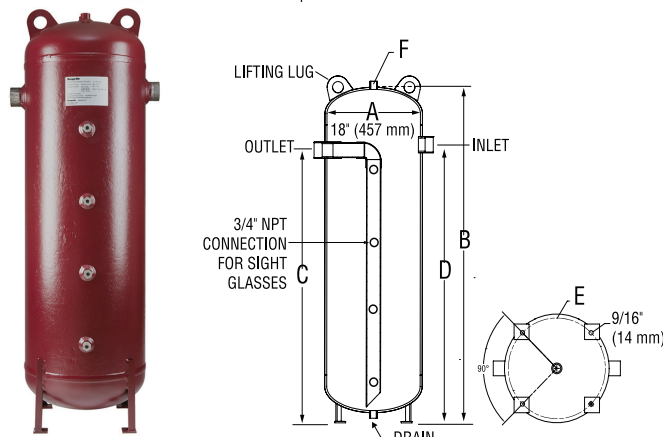

VR18-60

Part #	Model	Inlet/Outlet	A Dim. Dia.	B Dim. Height	C Dim. Outlet Loc.	D Dim. Inlet Loc.	E Dim. Mounting Bolt Center	F Dim. FPT*	Internal Volume	Code of Construction
95110200	VR10-20	1-1/8" ODS*	273 mm 10-3/4"	524 mm 20-5/8"	337 mm 13-1/4"	362 mm 14-1/4"	343 mm 13-1/2"	1/2"	22.71 Liter 6.0 gal	ASME
95112240	VR12-24	1-3/8" ODS*	324 mm 12-3/4"	622 mm 24-1/2"	410 mm 16-1/8"	435 mm 17-1/8"	391 mm 15-3/8"	1/2"	39.40 Liter 10.41 gal	ASME
95114360	VR14-36	1-5/8" ODS*	356 mm 14"	932 mm 36-11/16"	711 mm 28"	737 mm 29"	330 mm 13"	3/4"	72 Liter 19.04 gal	ASME
95116480	VR16-48	2-1/8" ODS*	406 mm 16"	1287 mm 50-11/16"	1016 mm 40"	1041 mm 41"	381 mm 15"	3/4"	134.94 Liter 35.65 gal	ASME
95118600	VR18-60	2-5/8" ODS*	457 mm 18"	1516 mm 59-11/16"	1231 mm 48-1/2"	1257 mm 49-1/2"	431 mm 17"	3/4"	208.19 Liter 55 gal	ASME

* FPT = Female Pipe Thread, ODS = Outside Diameter Solder

Optional Items

Pressure Differential Indicator (PDI)

Temprite's Pressure Differential indicator (PDI) lets you know when the filter inside a Temprite 920 or 920R Series coalescent oil separator should be changed.

- A dirt-laden filter can severely affect the performance of a 920 or 920R Series oil separator.
- Mounted atop or next to the Temprite 920 or 920R Series coalescent oil separator, the PDI measures the difference in pressure between the inlet and the outlet of the separator.
- If the PDI shows 11 to 13 PSID differential pressure, it's time to change the filter.



Part Number	Model #	Connection	Electric	Max. Working Press.
022400000	224	1/4" SAE*	60 W 3 A 24v N.O.	650 PSI

* SAE = 45° Flare Connection

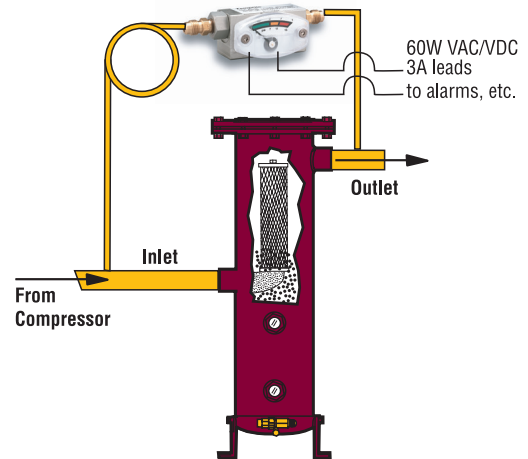

Drier Shells for CO₂

Maximum Working Pressure: 140 bar (2030 PSI)

Compatible with traditional refrigerants, new blends and natural refrigerants.*

* Traditional refrigerants such as R-22 and blendslike R-404a; new blends such as R-427a and R-448a; and natural refrigerants such as ammonia (NH₃) and CO₂.

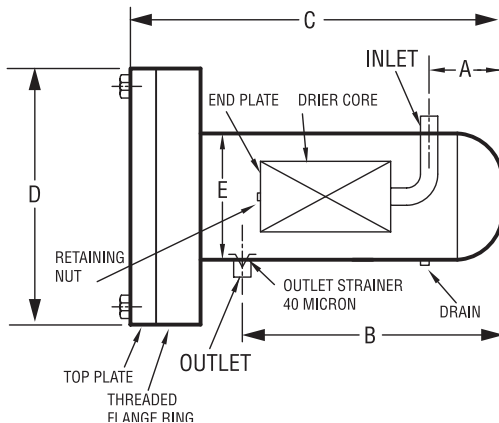

48-1

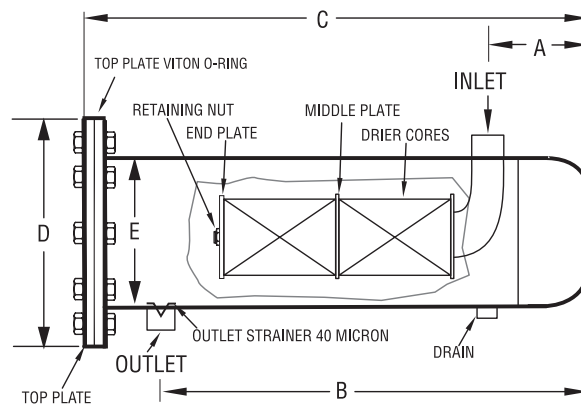

48-2

Part #	Model #	Inlet/ Outlet Conn.	Drain Conn.	A Dim.	B Dim.	C Dim.	D Dim.	E Dim.
				Inlet	Outlet	Overall Length	Flange Diameter	Shell Diameter
013701148	48-1	1-1/4" BW*	1/4" FPT*	117 mm 4-5/8"	384 mm 15-1/8"	500 mm 19-11/16"	216 mm 8-1/2"	141 mm 5-9/16"
013701248	48-2	1-1/4" BW*	1/4" FPT*	117 mm 4-5/8"	524 mm 20-5/8"	639 mm 25-1/8"	216 mm 8-1/2"	141 mm 5-9/16"

* FPT = Female Pipe Thread, BW = Butt Weld

For replacement parts, see page 35.

Filter Kits



Temprite Filtration Technology

Temprite coalescent oil separators employ a matrix-type borosilicate filter to do the work formerly done by impingement screens. The pure, fine glass fibers in the filter cause the oil molecules to collide, creating bigger droplets, until each is large enough to be forced to the outer drain layer of the filter. The droplets fall to the bottom of the separator and the oil is returned to the compressor.

The biggest energy drains on any refrigeration system are dirt, contaminants and excess refrigerant oil. New refrigerants coming onto the market have an enhanced solvent effect, meaning more contaminants than ever can be clogging your system. Solid contaminants in the system are harmful to sensors and other delicate components. Eliminating solid contaminants and excess oil from the system enhances the entire system's performance:

- The Temprite Standard Filter is finer than any other filter, picking up all effluent and dirt in the system down to 0.3 microns in size, increasing system efficiency and lowering energy costs.
- Thermostatic Expansion Valves (TXV) work more efficiently.
- Desiccant in filter driers is more effective when not logged with oil that prevents moisture from being absorbed.

Temprite®130 Series Replacement Filter Kits

Standard Filter Kits*

Part Number	For Model	A Nominal	B Nominal
62021133	133A	1"	5"
62021135	135A	2"	9"
62021137	137A	3.5"	14"
62021138	138A	3.5"	20"
62021139	139A	5.1"	19"

*All Filter Kits include O-Ring and Sealing Washer.

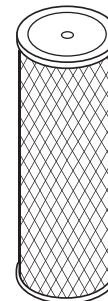

Standard

Clean-Up Burnouts with a Temprite Clean-Up® Filter

Another advantage of Temprite coalescent oil separators is that, should the compressor burn out, all effluent is localized in the separator, sparing delicate metering devices from a rush of burnt particles.

After a burnout in an accessible coalescent oil separator, simply install a Temprite Clean-Up® Filter to purge the system of contaminants. Using a Clean-Up® Filter in conjunction with a coalescent oil separator can return the oil to near-virgin state.

Clean-Up® Filter Kits*

Part Number	For Model	A Nominal	B Nominal
62022133	133A	1"	5"
62022135	135A	2"	9"
62022137	137A	3.5"	14"
62021138	138A	3.5"	20"
62022139	139A	5.1"	19"

* All Filter Kits include O-Ring and Sealing Washer.

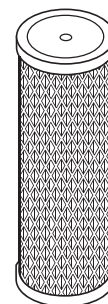

Clean-Up®

Replacement Parts

Temprite® 920 & 920R Series Filter Kits



Standard Filter Kits

Part #	For Model	A Nominal	B Nominal
62034000	922*, 923*, 922R*, 923R*	1"	5"
62037000	924*, 925*, 924R*, 925R*	2"	9"
62028000	926+, 927+, 926R+, 927R+	3-1/2"	14"
62051000	928!, 928R!	5-1/8"	16"
62085000	930!, 930R!	8-1/2"	16"

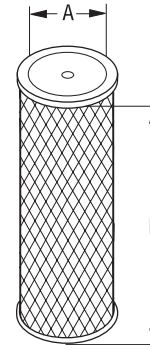

Clean-Up® Filter Kits

Part #	For Model	A Nominal	B Nominal
62024000	922*, 923*, 922R*, 923R*	1"	5"
62047000	924*, 925*, 924R*, 925R*	2"	9"
62030000	926+, 927+, 926R+, 927R+	3-1/2"	14"
62092802	928!, 928R!	5-1/8"	16"
62086000	930!, 930R!	8-1/2"	16"

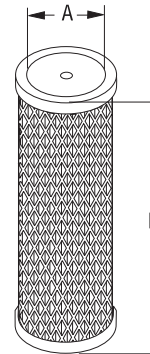

* Kit includes Filter, Gasket and Sealing Washer

+ Kit includes Filter, Gasket, O-Ring and Sealing Washer

! Kit includes Filter, two (2) different size O-Rings and Sealing Washer

Screen Kits

Part #	For Model
60001000	501*
60002000	502*
60003000	503*
60004000	504*
60005000	505*
60006000	506
60007000	507

*(2) Screens Included

Gasket included in all Kits

4" Bottom Plate Gaskets & 4" Top Plate Gaskets

Part #	For Model	Quantity
55000010	501-507, 922-930	10 Pack

6" Top Plate Gaskets/O-Rings

Part #	For Model	Quantity
55100005*	926, 927, 926R, 927R	5 Pack

* (5) each O-Rings and Gaskets

O-Ring/Gasket Kits

Part #	For Model
55928000	928, 928R
55930000	930, 930R

Kit contains (1) Large, (1) Small O-Ring and (1) 4" Gasket

O-Rings

Part #	For Model
55881135 (-338)	133A, 135A
55881137 (-350)	137A, 138A, 48-2, 48-1
55881139 (-365)	139A
55881148 (-350)	48-2, 48-1 (Viton option)

Float & Plate Assemblies

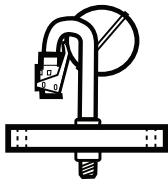

Part # 52200000

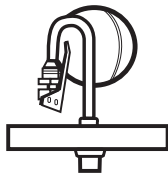

Part # 52200717

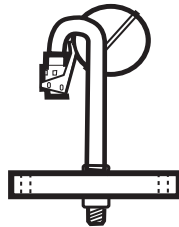

Part # 52300000

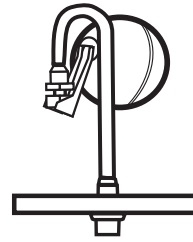

Part # 52300717

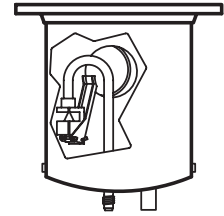

Part # 059260000D

Part Number	Description	For Model
51100000*	Fit/Ndl Assy	501-505
51200000*	Fit/Ndl Assy	506, 507
52200000*	FitBllAssyW/Btom Plt w/Drain	506, 507, 926 (Top Load), 927 (Top Load)
52200717*†	FitBllAssyW/Btom Plt w/Drain	506, 507, 926, 927 ammonia
52300000*	FitBllAssyW/Btom Plt w/Drain	508-510, 928, 930
52300717*†	FitBllAssyW/Btom Plt w/Drain	928, 930 ammonia
059260000D*	Btm Dome Assy w/Drain	926 (Old Style), 927 (Old Style)

*Gasket Included.

†Ammonia compatible

Sight Glasses

Part Number	For Model
76115000	15/16"-20THRD (Marked)
76116000	1-1/8"-18THRD (Unmarked)
76118000	3/4" NPT THRD w/ Float Ball 650 PSI (Unmarked)
76118130	3/4" NPT THRD w/ Float Ball (Marked) No O-Ring 1885 PSI



Part # 76118130

Drier Shell Replacement Parts

Part #	Description
30997248	Drier Shell End Plate
30996248	Drier Shell Divider Plate
61089248	Drier Shell Strainer/Assembly

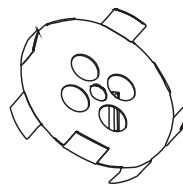

End Plate

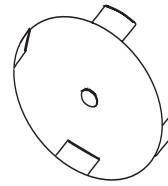

Divider Plate

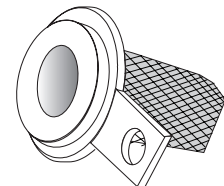

Strainer/Assembly

International Distribution

The Temprite plant is in West Chicago, Illinois, USA, with distribution facilities in Tokyo, Japan; Glasgow, UK; Stuttgart, Germany; Ankara, Turkey; Bangalore, India; and Sydney, Australia.

Temprite has worldwide distribution through wholesalers and direct sales to original equipment manufacturers, retailers and medical organizations, and through strategic partners in Europe, Japan, Australia, China, India, Vietnam, Germany and Turkey.

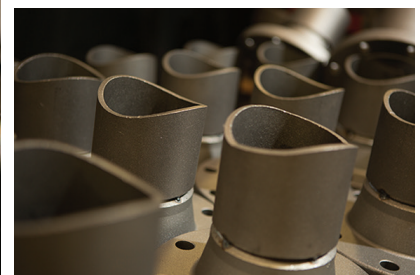
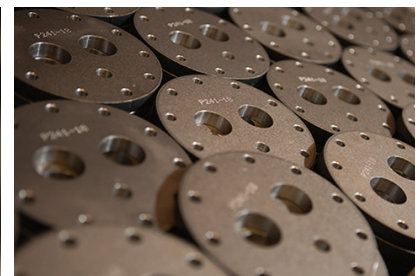



**Input your system specs into Temprite's Product Selector at www.temprite.com
and find the right Temprite products for you.**

Temprite's **Savings Calculator** quickly computes the amount of energy cost savings and reduction in carbon emissions when you use Temprite separators on your refrigeration system.

1.800.552.9300 / 1.630.293.5910 / Fax: 1.630.293.9594 www.temprite.com email: temprite@temprite.com

Distributed by:

Temprite[®]

1555 West Hawthorne Lane, Suite 1E
West Chicago, Illinois 60185-1822 USA
Phone: 1.800.552.9300 / 1.630.293.5910
Fax: 1.630.293.9594
email: temprite@temprite.com
www.temprite.com

Specifications subject to change without notice.

Copyright © 2018 Temprite. All Rights Reserved 9/18