

TCA7

SmartComfort® TXT+

High Efficiency 17 SEER Two-Stage Air Conditioner with Ion® Communicating System



Product Specifications

2 THRU 5 TONS SPLIT SYSTEM

208/230 Volt, 1-phase, 60 Hz

REFRIGERATION CIRCUIT

- Copeland Scroll® Ultratech™ compressors on all models
- Filter-drier supplied with every unit for field installation
- External high and low refrigerant service ports
- High and low pressure switches
- Copper tube / aluminum fin coil

PERFORMANCE

- Self-configuring installation capabilities with Ion® System Control
- Outdoor temperature sensor factory installed (for use with Ion® System Control only)
- Ball Bearing PSC fan motors on all models
- High performance compressor sound shield standard
- Isolation compressor grommets

EASY TO INSTALL AND SERVICE

- Text based diagnostics with Ion® Wall Control
- Only 2 control wires required from communicating indoor unit to condenser
- Easy access service valves on all models
- Innovative control box design
- Only two screws to access control panel
- Factory charged with R-410A refrigerant

BUILT TO LAST

- High gloss, baked-on powder coat finish over galvanized steel
- Post-painted (black) coil fins
- Coated, weather-resistant cabinet screws
- Coated inlet grille with 3/8" (10mm) spacing for extra protection
- Corner posts for extra strength and style

WARRANTY*

- 10 year No Hassle Replacement limited warranty
- 5 year parts limited warranty (including compressor and coil)
- With timely registration, an additional 5 year parts limited warranty (including compressor and coil)

* Applies to original purchaser/homeowner, some limitations may apply. See Warranty certificate for complete details.



SYST0101CW
(Sold Separately)



This product has been designed and manufactured to meet ENERGY STAR criteria for energy efficiency when matched with appropriate coil components. However, proper refrigerant charge and proper air flow are critical to achieve rated capacity and efficiency. Installation of this product should follow the manufacturer's refrigerant charging and air flow instructions. Failure to confirm proper charge and airflow may reduce energy efficiency and shorten equipment life.



Use of the AHRI Certified TM Mark indicates a manufacturer's participation in the program. For verification of certification for individual products, go to www.ahridirectory.org.

A210042TS

Model Number	Size (tons)	Nominal Btu/hr	Min. Circuit Ampacity	Max. Fuse or Breaker	Operating Dimensions height x width x depth in. (mm)	Ship / Operating Weight lbs. (kg)
TCA724GKA	2	24,000	14.5	20	35-1/2x31-3/16x31-3/16 (902x792x792)	222/183 (101/83)
TCA736GKA	3	36,000	19.8	35	35-1/2x31-3/16x31-3/16 (902x792x792)	256/217 (116/98)
TCA748GKA	4	48,000	27.8	40	40-3/8x35x35 (1026x889x889)	326/283 (148/128)
TCA760GKB	5	60,000	37.3	60	40-3/8x35x35 (1026x889x889)	327/284 (148/129)

Table 1 – Outdoor Unit Model Number Identification Guide (single phase)

Digit Position:	1	2	3	4	5, 6	7	8	9	10	11	12
Example Part Number:	T	C	A	7	24	G	K	A	2	0	0
T = Tempstar Mainline	BRANDING		KEY CHARACTERISTIC	TYPE	NOMINAL EFFICIENCY	NOMINAL CAPACITY	FEATURES	VOLTAGE			
C = Communicating											
A = Air Conditioner											
H = Heat Pump											
6 = 16 SEER											
7 = 17 SEER											
8 = 18 SEER											
9 = 19 SEER											
24 = 24,000 BTUH = 2 tons											
36 = 36,000 BTUH = 3 tons											
48 = 48,000 BTUH = 4 tons											
60 = 60,000 BTUH = 5 tons											
G = Coil Guard Grille											
K = 208/230-1-60											
Sales Code											
Engineering Revision											
Extra Digit											
Extra Digit											

Table 2 – Accessories Part Number Identification Guide

Digit Position:	1	2	3	4	5	6, 7	8, 9	10, 11
Example Part Number:	N	A	S	A	0	01	01	CH
N = Non-Branded	PRODUCT GROUP		KIT USAGE	MAJOR SERIES	REFRIGERANT			
A = Accessory								
S = Split System (AC & HP)								
A = Original								
B = 2nd Generation								
0 = Generic or Not Applicable								
4 = R-410A								
Product Identifier Number								
Package Quantity								
Type of Kit (Example: CH = Crankcase Heater)								

SIZE	SERIES	ELECTRICAL CHARACTERISTICS				A		B		C		D		E		F		G		H		I		J		K		OPERATING WEIGHT		SHIPPING WEIGHT		SHIPPING LENGTH / WIDTH (Sq.)		SHIPPING HEIGHT	
		Y	N	N	N	INCH	MM	INCH	MM	INCH	MM	INCH	MM	INCH	MM	INCH	MM	INCH	MM	INCH	MM	INCH	MM	INCH	MM	INCH	MM	Lbs	Kgs	Lbs	Kgs	INCH	MM	INCH	MM
24	2	Y	N	N	N	31 3/16	792.5	35 1/2	902.0	3/4	19.1	6 9/16	166.1	24 11/16	626.3	9 1/8	231.3	5/16	7.9	3	76.2	15 7/8	403.2	16 1/2	419.1	17 3/4	450.9	183	83.0	200	90.7	34 1/4	870.0	40 5/8	1031.3
36	2	Y	N	N	N	31 3/16	792.5	35 1/2	902.0	7/8	22.2	6 9/16	166.1	24 11/16	626.3	9 1/8	231.3	5/16	7.9	3	76.2	16	406.4	15 1/2	393.7	17 1/2	444.5	217	98.4	234	106.1	34 1/4	870.0	40 5/8	1031.3
48	2	Y	N	N	N	35	889.0	40 3/8	1026.3	7/8	22.2	6 9/16	166.1	28 7/16	722.8	9 1/8	231.3	5/16	7.9	3	76.2	17 1/4	438.2	17 1/4	438.2	18 1/2	469.9	283	128.4	305	138.3	37 13/16	960.0	45 3/16	1147.4
60	1	Y	N	N	N	35	889.0	40 3/8	1026.3	7/8	22.2	6 9/16	166.1	28 7/16	722.8	9 1/8	231.3	5/16	7.9	3	76.2	16 1/2	419.1	16 1/4	412.8	17 1/2	444.5	284	128.8	306	138.8	37 13/16	960.0	45 3/16	1147.4

208-230-1-60	Y=YES N=NO
208(230-3-60)	
460-3-60	
575-3-60	

NOTES:

1. CENTER OF GRAVITY

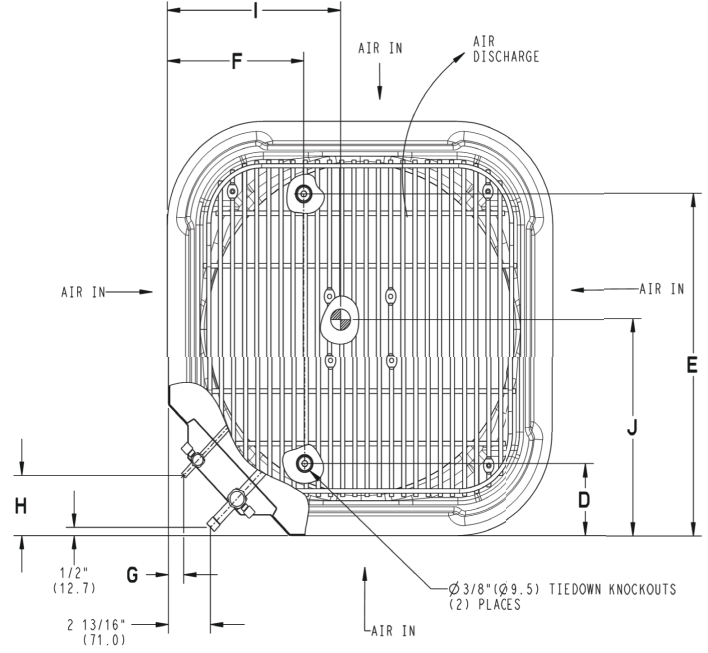
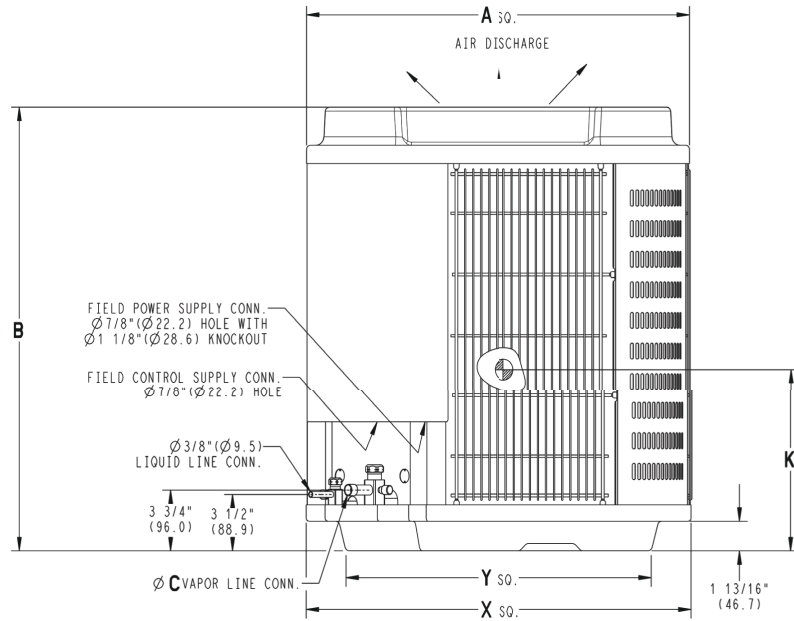

UNIT SIZE	"X"		"Y"	
	MINIMUM GROUND MOUNTING PAD APPLICATION DIMENSIONS		MINIMUM ROOF-TOP MOUNTING PAD APPLICATION DIMENSIONS	
-	23 1/8	587.3	17 7/8	454.6
-	25 3/4	654.0	20 7/16	518.5
24,36	31 3/16	792.5	22 15/16	583.2
48,60	35	889.0	26 3/4	679.7

NOTE: ALL DIMENSIONS IN INCH (MM)

U.S. ECCN: Not Subject to Regulation (N.S.R.)

Copy of SD5154-4 REV. G

Fig. 1 – Dimensional Drawing

Manufacturer reserves the right to change, at any time, specifications and designs without notice and without obligations.

Table 3 – Physical Data

Model Size	24	36	48	60
Nominal Cooling Capacity (BTU/hr)	24,000	36,000	48,000	60,000
Sound Rating*, High Stage (dBA)	72	71	72	72
Low Stage (dBA)	71	70	70	72
PSC Fan Motor HP	1/12	1/10	1/4	1/4
Fan RPM	800	825	825	825
Fan CFM	2481	3068	4700	4700
Coil Face Area ft ² (m ²)	19.58	19.38	25.12	25.12
Coil Rows - fins per inch	1-25	2-20	2-20	2-20
Low Pressure Switch				
Open Pressure	50 ± 7 PSIG	50 ± 7 PSIG	50 ± 7 PSIG	50 ± 7 PSIG
Close Pressure	95 ± 7 PSIG	95 ± 7 PSIG	95 ± 7 PSIG	95 ± 7 PSIG
Hi Pressure Switch				
Open Pressure	670 ± 10 PSIG	670 ± 10 PSIG	670 ± 10 PSIG	670 ± 10 PSIG
Close Pressure	470 ± 25 PSIG	470 ± 25 PSIG	470 ± 25 PSIG	470 ± 25 PSIG
Liquid Line Connection Size in. (mm)	3/8 (10)	3/8 (10)	3/8 (10)	3/8 (10)
Vapor Line Connection Size in. (mm)	3/4 (19)	7/8 (22)	7/8 (22)	7/8 (22)
Recommended Line Set Liquid Tube Diameter in. (mm)	3/8 (10)	3/8 (10)	3/8 (10)	3/8 (10)
Recommended Line Set Vapor Tube Diameter in. (mm)*	3/4 (19)*	7/8 (22)†	1-1/8 (29)†	1-1/8 (29)†
Factory Charge R-410A lbs. (kg)	6.64 (3.01)	9.26(4.20)	12.94 (5.87)	12.70 (5.76)
Required Subcooling °F (°C)	10 (5.6)	14 (7.8)	13 (7.2)	14 (7.8)

*. Sound Rating tested in accordance with AHRI Standard 270-95 (not listed with AHRI)

†. Recommended Vapor Tube Line size is for standard installations. These recommendations may not apply to “Long Line” installations. When the total equivalent line length exceeds 80 feet (24.4m) or there is more than 20 feet (6.1m) vertical separation between indoor and outdoor units, consult the Long Line Application Guideline document before purchasing/installing line sets.

Table 4 – Electrical Data (208/230-1-60 — voltage range 197–253V)

Model Size	24GKA2	36GKA2	48GKA2	60GKB1
Minimum Circuit Ampacity — MCA (amps)	14.5	19.8	27.8	37.3
Maximum OverCurrent Protective device — MOCP (amps)	20	35	40	60
Compressor RLA (Rated Load Amps)	11.1	15.3	21.2	28.8
LRA (Locked Rotor Amps)	58.3	83.0	104.0	152.9
Fan Motor FLA (Full Load Amps)	0.6	0.7	1.3	1.3

Table 5 – R-410A Cooling Capacity Loss for Various Line Lengths and Tube Diameters

Unit Nominal Size (Btuh)	Maximum Liquid Line Diameter (OD) in.(mm)	Vapor Line Diameters (OD) in. (mm)	Cooling Capacity Loss (%) at Total Equivalent Line Length, feet (m)								
			26-50 (7.9-15.2)	51-80 (15.5-24.4)	81-100 (24.7-30.5)	101-125 (30.8-38.1)	126-150 (38.4-45.7)	151-175 (46.0-50.3)	176-200 (53.6-60.0)	201-225 (61.3-68.6)	226-250 (68.9-76.2)
24 2-Stage AC	3/8 (10)	5/8 (16)	0	1	1	2	3	3	4	4	5
		3/4 (19)	0	0	0	0	1	1	1	1	1
36 2-Stage AC		5/8 (16)	1	2	4	5	6	7	9	10	11
		3/4 (19)	0	0	1	1	2	2	3	3	4
48 2-Stage AC		7/8 (22)	0	0	0	0	1	1	1	1	2
		3/4 (19)	1	2	2	3	4	5	6	7	7
		7/8 (22)	0	1	1	2	2	2	3	3	3
60 2-Stage AC		1-1/8 (29)	0	0	-	-	-	-	-	-	-
		3/4 (19)	1	2	4	5	6	7	9	10	10
		7/8 (22)	0	1	2	2	2	3	4	4	5
		1-1/8 (29)	0	0	0	0	1	1	1	1	1

Applications in shaded area may be long line and may have height restrictions. See the AC & HP R410A Split System Long Line Applications Guideline.

- Applications in this area are not recommended due to insufficient oil return.

Tested AHRI Combination Ratings

NOTE: Ratings contained in this document are subject to change at any time.
 For AHRI ratings certificates, please refer to the AHRI directory. www.ahridirectory.org
 Additional ratings and system combinations can be accessed via the Tempstar database at:
<http://www.icpeqp.com/AHRIratings/ratings.aspx?Brand=Tempstar>
 Or scan this QR code:



Table 6 – Cooling Performance

For complete ratings information, use the AHRI website directory search: www.AHRIdirectory.org . New ratings may be listed online before Specification Sheets are updated.							
Model Number	Indoor Model	AHRI STANDARD RATINGS - COOLING					
		Capacity		EER	SEER	ID SCFM	
		High	Low			High	Low
TCA724GKA	EN(A,D)4X31L17**+TDR	25000	21200	12.2	14.0	800	680
TCA736GKA	EA*4X37L21A*+TDR	36800	30200	12.2	14.0	1050	840
TCA748GKA	EA*4X61L24A*+TDR	49000	40500	12.5	15.0	1400	1120
TCA760GKB	EA*4X61L24A*+TDR	56500	47000	12.0	14.5	1625	1300

* AHRI = Air Conditioning, Heating & Refrigeration Institute

EERA — Energy Efficiency Ratio - 'A' conditions - 80°F (26.6°C) indoor db/67°F (19.4°C) indoor wb & 95°F (35° C) outdoor wb.

SEER — Seasonal Energy Efficiency Ratio

NOTES:

1. Ratings are net values reflecting the effects of circulating fan motor heat. Supplemental electric heat is not included.
2. Tested outdoor/indoor combinations have been tested in accordance with DOE test procedures for central air conditioners. Ratings for other combinations are determined under DOE computer simulation procedures.
3. Determine actual CFM values obtainable for your system by referring to fan performance data in fan coil or furnace coil literature.
4. Do not apply with capillary tube coils as performance and reliability are significantly affected.

SIZE 24 EXPANDED DATA

		High Stage 24 Size Outdoor With EN(A,D)4X31L17** Indoor Cooling																								
		Outdoor Ambient Temperature - Degrees F, Dry Bulb																								
		75					85					95					105					115				
		Entering Indoor Temperature - Degrees F, Wet Bulb																								
CFM		57	62	63††	67	72	57	62	63††	67	72	57	62	63††	67	72	57	62	63††	67	72	57	62	63††	67	72
600	MBh†	22.30	23.76	24.22	26.19	28.90	21.56	22.78	23.22	25.11	27.71	20.75	21.72	22.14	23.94	26.43	19.87	20.59	20.97	22.69	25.06	18.91	19.38	19.73	21.36	23.62
	S/T‡	1.00	0.85	0.69	0.66	0.50	1.00	0.87	0.70	0.67	0.50	1.00	0.88	0.71	0.68	0.50	1.00	0.91	0.72	0.70	0.51	1.00	0.93	0.74	0.71	0.52
	AMPS*	7.00	7.04	7.05	7.10	7.17	7.68	7.72	7.73	7.78	7.84	8.47	8.50	8.51	8.56	8.62	9.40	9.42	9.43	9.47	9.53	10.48	10.50	10.51	10.55	10.62
	HI PR	261	263	263	265	268	302	304	305	307	311	349	351	351	354	358	400	401	402	405	409	455	456	457	460	464
	LO PR	119	126	128	138	151	122	128	130	140	154	125	130	132	142	156	129	133	135	145	158	132	135	137	147	161
650	MBh†	22.98	24.16	24.61	26.60	29.33	22.20	23.17	23.58	25.48	28.10	21.35	22.08	22.46	24.27	26.78	20.42	20.90	21.26	22.99	25.37	19.43	19.68	19.98	21.62	23.88
	S/T‡	1.00	0.87	0.70	0.67	0.50	1.00	0.89	0.71	0.69	0.51	1.00	0.91	0.72	0.70	0.51	1.00	0.94	0.74	0.71	0.52	1.00	0.96	0.76	0.73	0.53
	AMPS*	7.10	7.13	7.15	7.20	7.26	7.79	7.81	7.82	7.87	7.93	8.57	8.59	8.60	8.65	8.71	9.49	9.50	9.51	9.56	9.62	10.58	10.58	10.59	10.64	10.71
	HI PR	262	263	264	266	269	304	305	306	308	312	350	351	352	354	358	401	401	402	405	409	457	457	458	461	465
	LO PR	123	128	130	140	154	125	130	132	142	156	129	133	134	145	158	132	135	137	147	161	136	138	139	150	163
700	MBh†	23.59	24.52	24.95	26.95	29.70	22.78	23.50	23.88	25.79	28.43	21.89	22.38	22.73	24.56	27.08	20.92	21.19	21.50	23.24	25.63	19.89	20.37	20.19	21.84	24.11
	S/T‡	1.00	0.90	0.72	0.69	0.51	1.00	0.92	0.73	0.70	0.51	1.00	0.94	0.74	0.72	0.52	1.00	0.96	0.76	0.73	0.53	1.00	0.93	0.78	0.75	0.54
	AMPS*	7.20	7.23	7.24	7.29	7.35	7.88	7.90	7.91	7.96	8.02	8.67	8.68	8.69	8.74	8.79	9.59	9.59	9.61	9.65	9.71	10.68	10.69	10.69	10.73	10.80
	HI PR	263	264	264	266	270	305	306	306	309	312	351	352	352	355	359	402	402	403	406	410	458	458	458	461	466
	LO PR	126	131	132	143	156	129	133	134	145	158	132	135	136	147	160	136	137	138	149	163	139	142	141	151	165
750	MBh†	24.15	24.84	25.24	27.24	30.01	23.31	23.79	24.14	26.06	28.71	22.38	22.66	22.96	24.80	27.32	21.38	21.47	21.70	23.45	25.84	20.30	20.34	20.37	22.02	24.29
	S/T‡	1.00	0.92	0.73	0.70	0.52	1.00	0.94	0.74	0.72	0.52	1.00	0.96	0.76	0.73	0.53	1.00	0.99	0.78	0.75	0.54	1.00	1.00	0.80	0.77	0.55
	AMPS*	7.30	7.32	7.33	7.38	7.44	7.98	7.99	8.00	8.05	8.11	8.76	8.77	8.78	8.82	8.88	9.68	9.68	9.69	9.74	9.80	10.77	10.77	10.77	10.82	10.88
	HI PR	263	264	265	267	270	306	306	307	309	313	352	352	353	355	359	403	403	403	406	410	459	459	459	462	466
	LO PR	129	133	134	144	158	132	135	136	146	160	135	137	138	148	162	139	139	140	151	164	142	143	142	153	167
800	MBh†	24.66	25.13	25.49	27.50	30.28	23.78	24.06	24.37	26.30	28.94	22.82	22.94	23.16	25.00	27.52	21.79	22.00	21.88	23.62	26.02	20.68	20.71	20.52	22.18	24.44
	S/T‡	1.00	0.94	0.75	0.72	0.52	1.00	0.96	0.76	0.73	0.53	1.00	0.99	0.78	0.75	0.54	1.00	0.98	0.80	0.77	0.55	1.00	1.00	0.82	0.80	0.56
	AMPS*	7.39	7.41	7.41	7.46	7.53	8.07	8.08	8.09	8.13	8.19	8.86	8.86	8.87	8.91	8.97	9.78	9.78	9.78	9.82	9.88	10.87	10.87	10.86	10.90	10.97
	HI PR	264	265	265	267	270	306	307	307	309	313	353	353	353	356	360	404	404	404	407	411	459	460	459	462	466
	LO PR	132	134	136	146	160	135	136	138	148	162	138	139	139	150	164	142	143	142	152	166	145	145	144	154	168
835	MBh†	24.99	25.34	25.64	27.66	30.44	24.09	24.26	24.51	26.44	29.09	23.10	23.33	23.28	25.12	27.65	22.05	22.08	21.99	23.74	26.13	20.92	20.95	20.61	22.27	24.53
	S/T‡	1.00	0.96	0.76	0.73	0.53	1.00	0.98	0.77	0.75	0.54	1.00	0.97	0.79	0.76	0.55	1.00	1.00	0.81	0.79	0.56	1.00	1.00	0.84	0.81	0.57
	AMPS*	7.46	7.47	7.48	7.52	7.59	8.14	8.14	8.15	8.19	8.25	8.92	8.93	8.93	8.97	9.03	9.84	9.84	9.84	9.88	9.94	10.93	10.93	10.92	10.97	11.03
	HI PR	264	265	265	267	271	307	307	307	310	313	353	353	354	356	360	404	404	404	407	411	460	460	459	462	467
	LO PR	134	136	137	147	161	137	138	139	149	163	140	141	140	151	165	143	144	142	153	167	147	147	145	155	169
900	MBh†	25.55	25.69	25.89	27.92	30.70	24.61	24.84	24.73	26.66	29.32	23.59	23.62	23.48	25.33	27.85	22.49	22.52	22.16	23.91	26.30	21.32	21.35	20.77	22.42	24.67
	S/T‡	1.00	0.98	0.78	0.75	0.54	1.00	0.98	0.79	0.77	0.55	1.00	1.00	0.81	0.79	0.56	1.00	1.00	0.83	0.81	0.57	1.00	1.00	0.86	0.84	0.58
	AMPS*	7.58	7.59	7.59	7.64	7.70	8.26	8.26	8.26	8.31	8.36	9.04	9.04	9.04	9.08	9.14	9.96	9.96	9.96	9.99	10.05	11.05	11.05	11.03	11.08	11.14
	HI PR	265	265	266	268	271	308	308	308	310	314	354	354	354	357	360	405	405	405	407	411	461	461	460	463	467
	LO PR	137	138	138	149	163	140	141	140	151	164	143	143	142	153	166	147	147	144	155	168	150	150	146	157	170

† Total capacities are net (I.D blower heat subtracted) system capacities based on 25' line set.

If additional tubing length and/or indoor unit is located above outdoor unit, a slight variation in capacity may occur.

* System amps are total of indoor and outdoor amps

‡ S/T are based on 80 °F db entering air at the indoor coil. For sensible capacities at other than 80 °F db, deduct 835 Btuh per 1000 cfm of indoor coil air from MBh/S/T for each degree below 80 °F, or add 835 Btuh per 1000 cfm of indoor coil air from MBh/S/T for each degree above 80 °F

†† At TVA rating indoor condition (75 °F db/ 63 °F wb), All other indoor air temperatures are at 80 °F db

Manufacturer reserves the right to change, at any time, specifications and designs without notice and without obligations.

SIZE 24 EXPANDED DATA

Low Stage 24 Size Outdoor With EN(A,D)4X31L17** Indoor Cooling																										
Outdoor Ambient Temperature - Degrees F, Dry Bulb																										
75						85					95					105					115					
Entering Indoor Temperature - Degrees F, Wet Bulb																										
CFM	57	62	63††	67	72	57	62	63††	67	72	57	62	63††	67	72	57	62	63††	67	72	57	62	63††	67	72	
450	MBh†	17.13	18.23	18.60	20.17	22.34	15.55	16.39	16.73	18.14	20.09	13.98	14.57	14.86	16.13	17.89	12.43	12.79	13.04	14.18	15.75	20.95	21.11	21.32	12.33	13.73
	S/T‡	1.00	0.86	0.69	0.66	0.50	1.00	0.88	0.70	0.67	0.50	1.00	0.90	0.72	0.69	0.51	1.00	0.93	0.74	0.71	0.51	1.00	0.96	0.76	0.73	0.52
	AMPS*	4.98	4.94	4.92	4.85	4.76	5.62	5.58	5.57	5.50	5.40	6.34	6.31	6.30	6.24	6.15	7.14	7.14	7.14	7.08	7.01	8.09	8.08	8.07	8.03	7.98
	HI PR	250	251	252	253	256	291	292	292	294	296	335	336	337	339	341	384	385	386	388	390	438	439	439	441	445
	LO PR	122	129	131	141	154	125	131	133	143	157	129	134	136	146	160	133	136	138	149	162	138	139	141	151	165
500	MBh†	17.84	18.65	19.01	20.60	22.79	16.18	16.76	17.08	18.50	20.48	14.53	14.88	15.15	16.43	18.21	12.91	13.06	13.29	14.43	16.01	21.36	21.37	21.52	12.54	13.93
	S/T‡	1.00	0.89	0.71	0.68	0.51	1.00	0.91	0.72	0.70	0.51	1.00	0.94	0.74	0.71	0.52	1.00	0.97	0.76	0.73	0.53	1.00	1.00	0.78	0.76	0.54
	AMPS*	5.03	4.99	4.98	4.91	4.82	5.67	5.64	5.63	5.56	5.46	6.39	6.37	6.36	6.30	6.21	7.21	7.21	7.21	7.20	7.14	8.15	8.14	8.15	8.10	8.05
	HI PR	251	252	252	254	256	292	292	293	295	297	336	337	337	339	342	385	386	386	388	391	439	439	440	442	445
	LO PR	127	132	134	144	158	130	134	136	146	160	134	137	138	149	163	138	139	141	151	165	142	143	144	154	168
550	MBh†	18.47	19.01	19.35	20.95	23.16	16.74	17.07	17.35	18.79	20.78	15.01	15.15	15.38	16.67	18.46	13.33	13.49	13.48	14.63	16.21	21.71	21.73	21.67	12.69	14.09
	S/T‡	1.00	0.92	0.73	0.70	0.52	1.00	0.95	0.75	0.72	0.52	1.00	0.97	0.76	0.74	0.53	1.00	0.97	0.79	0.76	0.54	1.00	1.00	0.81	0.79	0.55
	AMPS*	5.08	5.06	5.04	4.97	4.87	5.71	5.70	5.69	5.62	5.52	6.44	6.44	6.43	6.36	6.28	7.27	7.27	7.27	7.21	7.14	8.21	8.21	8.22	8.17	8.13
	HI PR	252	252	253	254	257	292	293	293	295	297	337	337	338	340	342	386	387	387	389	392	440	440	440	442	446
	LO PR	131	135	137	147	161	135	137	139	149	163	138	139	141	151	165	142	144	143	154	168	147	147	146	156	170
600	MBh†	19.02	19.33	19.62	21.24	23.46	17.22	17.35	17.58	19.03	21.03	15.43	15.62	15.57	16.87	18.65	13.69	13.71	13.63	14.79	16.37	21.02	21.04	21.79	12.82	14.22
	S/T‡	1.00	0.96	0.75	0.73	0.53	1.00	0.98	0.77	0.74	0.53	1.00	0.97	0.79	0.76	0.54	1.00	1.00	0.81	0.79	0.56	1.00	1.00	0.84	0.82	0.57
	AMPS*	5.13	5.12	5.11	5.04	4.94	5.77	5.76	5.76	5.68	5.59	6.50	6.49	6.50	6.43	6.34	7.33	7.33	7.34	7.28	7.21	8.28	8.28	8.30	8.25	8.20
	HI PR	253	253	253	255	257	293	293	294	295	298	338	338	338	340	343	387	387	387	389	392	441	441	441	443	446
	LO PR	135	137	139	149	163	139	140	141	151	165	142	144	143	153	167	146	146	145	156	170	150	151	148	158	172
650	MBh†	19.52	19.91	19.85	21.47	23.70	17.65	17.81	17.77	19.23	21.23	15.81	15.83	15.73	17.03	18.81	14.01	14.03	13.76	14.92	16.50	21.29	21.31	21.91	12.93	14.31
	S/T‡	1.00	0.95	0.77	0.75	0.54	1.00	0.98	0.79	0.77	0.55	1.00	1.00	0.81	0.79	0.56	1.00	1.00	0.84	0.82	0.57	1.00	1.00	0.87	0.85	0.59
	AMPS*	5.19	5.17	5.18	5.10	5.00	5.82	5.82	5.82	5.75	5.65	6.56	6.56	6.57	6.50	6.41	7.40	7.40	7.41	7.36	7.28	8.35	8.35	8.37	8.32	8.28
	HI PR	253	253	253	255	257	294	294	294	296	298	339	339	339	340	343	388	388	387	390	393	442	442	441	443	447
	LO PR	139	142	141	151	165	142	143	143	153	167	146	146	145	155	169	150	150	147	158	171	154	154	149	160	174
680	MBh†	19.78	20.10	19.97	21.59	23.83	17.89	17.92	17.87	19.33	21.33	16.01	16.04	15.81	17.11	18.89	14.18	14.21	13.82	14.99	16.56	21.44	21.46	21.95	12.98	14.36
	S/T‡	1.00	0.96	0.79	0.76	0.54	1.00	1.00	0.81	0.78	0.55	1.00	1.00	0.83	0.80	0.57	1.00	1.00	0.86	0.83	0.58	1.00	1.00	0.89	0.87	0.60
	AMPS*	5.22	5.20	5.22	5.14	5.04	5.86	5.86	5.87	5.79	5.69	6.59	6.59	6.61	6.54	6.46	7.44	7.43	7.46	7.39	7.33	8.39	8.39	8.42	8.37	8.32
	HI PR	253	254	254	255	257	294	294	294	296	298	339	339	339	341	343	388	388	388	390	393	442	442	441	444	447
	LO PR	141	143	142	152	166	144	144	144	154	168	148	148	146	156	170	152	152	148	159	172	156	156	150	161	174
700	MBh†	19.96	20.20	20.04	21.67	23.90	18.04	18.07	17.93	19.39	21.39	16.14	16.16	15.86	17.16	18.94	14.29	14.32	13.87	15.03	16.60	21.53	21.55	21.99	13.01	14.39
	S/T‡	1.00	0.97	0.80	0.77	0.55	1.00	1.00	0.82	0.79	0.56	1.00	1.00	0.84	0.81	0.57	1.00	1.00	0.87	0.84	0.59	1.00	1.00	0.90	0.88	0.60
	AMPS*	5.24	5.23	5.24	5.17	5.07	5.88	5.88	5.89	5.82	5.72	6.62	6.62	6.64	6.57	6.48	7.46	7.46	7.49	7.43	7.36	8.42	8.42	8.44	8.40	8.35
	HI PR	254	254	254	255	257	294	294	294	296	298	339	339	339	341	344	389	389	388	390	393	443	443	441	444	447
	LO PR	142	144	142	153	167	145	146	144	155	169	149	149	146	157	171	153	153	148	159	173	157	157	151	162	175
† Total capacities are net (I.D blower heat subtracted) system capacities based on 25' line set.																										
If additional tubing length and/or indoor unit is located above outdoor unit, a slight variation in capacity may occur.																										
* System amps are total of indoor and outdoor amps																										
‡ S/T are based on 80 °F db entering air at the indoor coil. For sensible capacities at other than 80 °F db, deduct 835 Btuh per 1000 cfm of indoor coil air from MBhxS/T for each degree below 80 °F, or add 835 Btuh per 1000 cfm of indoor coil air from MBhxS/T for each degree above 80 °F																										
†† At TVA rating indoor condition (75 °F db/ 63 °F wb), All other indoor air temperatures are at 80 °F db																										

Manufacturer reserves the right to change, at any time, specifications and designs without notice and without obligations.

SIZE 36 EXPANDED DATA

High Stage 36 Outdoor With EA*4X37L21A* Indoor Cooling																										
Outdoor Ambient Temperature - Degrees F, Dry Bulb																										
75					85					95					105					115						
Entering Indoor Temperature - Degrees F, Wet Bulb																										
CFM	57	62	63††	67	72	57	62	63††	67	72	57	62	63††	67	72	57	62	63††	67	72	57	62	63††	67	72	
900	MBh†	33.46	35.72	36.47	39.41	43.45	32.30	34.20	34.94	37.73	41.62	31.04	32.55	33.24	35.92	39.60	29.65	30.73	31.37	33.89	37.39	28.10	28.74	29.33	31.70	34.95
	S/T‡	1.00	0.85	0.69	0.66	0.50	1.00	0.87	0.70	0.67	0.50	1.00	0.89	0.71	0.69	0.51	1.00	0.92	0.73	0.70	0.51	1.00	0.95	0.75	0.72	0.52
	AMPS*	10.02	10.10	10.13	10.25	10.42	11.23	11.30	11.33	11.43	11.58	12.66	12.71	12.74	12.83	12.97	14.31	14.35	14.38	14.47	14.59	16.21	16.23	16.26	16.36	16.48
	HI PR	272	274	275	279	283	314	316	318	321	327	360	363	364	368	374	411	413	415	419	424	467	468	469	474	480
	LO PR	119	126	129	139	152	122	128	131	141	155	125	130	133	143	157	129	133	135	146	160	133	136	138	148	163
975	MBh†	34.48	36.31	37.05	40.02	44.08	33.27	34.75	35.45	38.28	42.18	31.95	33.05	33.70	36.39	40.11	30.48	31.18	31.79	34.33	37.82	28.85	29.15	29.67	32.04	35.33
	S/T‡	1.00	0.88	0.70	0.68	0.50	1.00	0.90	0.72	0.69	0.51	1.00	0.92	0.73	0.70	0.52	1.00	0.95	0.75	0.72	0.52	1.00	0.98	0.77	0.74	0.54
	AMPS*	10.18	10.25	10.28	10.40	10.57	11.39	11.45	11.47	11.58	11.73	12.82	12.86	12.87	12.97	13.11	14.46	14.50	14.52	14.62	14.74	16.37	16.40	16.41	16.50	16.63
	HI PR	273	275	276	280	284	315	318	318	322	327	362	364	365	369	374	413	414	415	420	425	468	469	470	474	481
	LO PR	122	129	131	141	155	125	131	133	143	157	129	133	135	145	159	132	135	137	148	162	137	138	140	151	165
1050	MBh†	35.40	36.83	37.54	40.53	44.61	34.14	35.21	35.89	38.74	42.67	32.76	33.48	34.10	36.80	40.53	31.23	31.58	32.12	34.67	38.01	29.52	29.57	29.97	32.33	35.62
	S/T‡	1.00	0.90	0.72	0.69	0.51	1.00	0.92	0.73	0.71	0.52	1.00	0.95	0.75	0.72	0.52	1.00	0.98	0.77	0.74	0.54	1.00	1.00	0.79	0.77	0.55
	AMPS*	10.34	10.39	10.42	10.54	10.72	11.55	11.59	11.61	11.72	11.87	12.97	12.99	13.01	13.11	13.25	14.62	14.64	14.65	14.75	14.84	16.53	16.53	16.56	16.64	16.77
	HI PR	274	276	276	280	285	317	318	319	323	328	363	364	365	370	375	414	415	416	420	425	470	470	471	475	481
	LO PR	126	131	133	143	157	129	133	135	145	159	132	135	137	147	162	136	137	139	150	164	140	140	142	152	167
1200	MBh†	37.04	37.72	38.34	41.34	45.45	35.66	36.06	36.60	39.46	43.39	34.18	34.41	34.72	37.42	41.16	32.53	32.57	32.66	35.22	38.72	30.68	30.72	30.41	32.80	36.09
	S/T‡	1.00	0.95	0.75	0.73	0.53	1.00	0.97	0.77	0.74	0.53	1.00	0.99	0.78	0.76	0.54	1.00	1.00	0.81	0.78	0.56	1.00	1.00	0.84	0.81	0.57
	AMPS*	10.65	10.67	10.69	10.82	11.00	11.85	11.87	11.88	11.99	12.15	13.27	13.28	13.30	13.39	13.53	14.94	14.93	14.93	15.03	15.16	16.83	16.83	16.83	16.92	17.05
	HI PR	277	277	278	281	286	319	320	321	324	330	366	366	367	371	376	417	417	417	422	427	472	472	472	477	483
	LO PR	132	135	136	147	161	135	137	138	149	163	138	139	140	151	165	142	142	142	153	167	146	146	144	155	170
1350	MBh†	38.41	38.92	38.91	41.93	46.03	36.94	37.01	37.11	39.99	43.92	35.35	35.40	35.20	37.90	41.63	33.60	33.64	33.06	35.45	39.10	31.63	31.68	30.76	33.13	36.39
	S/T‡	1.00	0.96	0.78	0.76	0.54	1.00	1.00	0.80	0.78	0.55	1.00	1.00	0.82	0.80	0.56	1.00	1.00	0.85	0.83	0.58	1.00	1.00	0.88	0.86	0.60
	AMPS*	10.94	10.97	10.96	11.09	11.28	12.15	12.15	12.15	12.26	12.42	13.57	13.57	13.56	13.66	13.80	15.24	15.23	15.20	15.25	15.43	17.13	17.15	17.11	17.20	17.33
	HI PR	278	279	279	282	287	321	321	321	325	330	368	368	368	372	378	420	419	418	421	428	475	475	473	478	484
	LO PR	138	140	139	150	164	141	141	141	152	166	144	144	143	153	168	147	148	145	156	170	151	152	147	158	172
† Total capacities are net (I.D blower heat subtracted) system capacities based on 25' line set.																										
If additional tubing length and/or indoor unit is located above outdoor unit, a slight variation in capacity may occur.																										
* System amps are total of indoor and outdoor amps																										
‡ S/T are based on 80 °F db entering air at the indoor coil. For sensible capacities at other than 80 °F db, deduct 835 Btuh per 1000 cfm of indoor coil air from MBhxS/T for each degree below 80 °F, or add 835 Btuh per 1000 cfm of indoor coil air from MBhxS/T for each degree above 80 °F																										
†† At TVA rating indoor condition (75 °F db/ 63 °F wb), All other indoor air temperatures are at 80 °F db																										

Manufacturer reserves the right to change, at any time, specifications and designs without notice and without obligations.

SIZE 36 EXPANDED DATA

Low Stage 36 Outdoor With EA*4X37L21A* Indoor Cooling																											
Outdoor Ambient Temperature - Degrees F, Dry Bulb																											
75					85					95					105					115							
Entering Indoor Temperature - Degrees F, Wet Bulb																											
CFM		57	62	63††	67	72	57	62	63††	67	72	57	62	63††	67	72	57	62	63††	67	72	57	62	63††	67	72	
720	MBh†	25.27	26.45	27.05	29.36	32.60	23.25	24.11	24.65	26.75	29.69	21.24	21.80	22.28	24.18	26.85	19.23	19.50	19.92	21.64	24.04	17.21	17.25	17.57	19.13	21.26	
	S/T‡	1.00	0.90	0.72	0.69	0.51	1.00	0.92	0.73	0.70	0.51	1.00	0.94	0.74	0.72	0.52	1.00	0.97	0.76	0.73	0.53	1.00	1.00	0.79	0.76	0.54	
	AMPS*	7.23	7.19	7.18	7.09	6.98	8.04	8.02	8.00	7.93	7.83	8.98	8.96	8.95	8.88	8.79	10.06	10.05	10.04	9.97	9.88	11.29	11.29	11.29	11.21	11.12	
	HI PR	257	258	259	261	264	298	299	299	302	306	343	344	344	347	351	392	393	393	393	397	401	446	446	447	450	455
	LO PR	128	133	135	145	159	131	135	137	147	161	134	137	139	149	163	137	139	141	152	166	141	142	144	154	168	
780	MBh†	26.04	26.87	27.45	29.78	33.07	23.93	24.48	24.99	27.11	30.08	21.85	22.12	22.57	24.49	27.17	19.76	19.81	20.17	21.89	24.30	17.67	17.70	17.77	19.31	21.47	
	S/T‡	1.00	0.93	0.73	0.71	0.52	1.00	0.95	0.75	0.72	0.52	1.00	0.98	0.76	0.74	0.53	1.00	1.00	0.78	0.76	0.54	1.00	1.00	0.81	0.78	0.55	
	AMPS*	7.30	7.27	7.25	7.17	7.06	8.11	8.09	8.08	8.01	7.91	9.05	9.04	9.03	8.97	8.87	10.13	10.13	10.12	10.06	9.97	11.37	11.37	11.37	11.30	11.21	
	HI PR	258	259	259	262	265	298	299	300	303	306	344	344	345	348	351	393	393	394	397	401	448	448	448	451	455	
	LO PR	131	135	137	148	161	134	137	139	149	163	137	139	141	151	165	141	141	143	154	168	145	145	145	156	170	
840	MBh†	26.72	27.25	27.79	30.14	33.44	24.55	24.81	25.28	27.41	30.40	22.39	22.45	22.81	24.74	27.44	20.24	20.27	20.36	22.10	24.52	18.08	18.11	17.93	19.48	21.65	
	S/T‡	1.00	0.96	0.75	0.73	0.52	1.00	0.98	0.77	0.74	0.53	1.00	1.00	0.79	0.76	0.54	1.00	1.00	0.81	0.78	0.55	1.00	1.00	0.84	0.81	0.57	
	AMPS*	7.37	7.35	7.33	7.25	7.14	8.19	8.18	8.17	8.09	7.99	9.13	9.12	9.11	9.05	8.96	10.21	10.21	10.20	10.14	10.05	11.44	11.44	11.45	11.38	11.29	
	HI PR	259	259	259	262	265	300	300	300	303	307	345	345	345	348	352	394	394	394	398	402	449	449	448	451	456	
	LO PR	135	137	139	149	163	138	139	141	151	165	141	141	143	153	167	144	145	145	155	170	148	149	147	158	172	
980	MBh†	28.12	28.46	28.40	30.78	34.12	25.78	25.85	25.80	27.95	30.98	23.48	23.52	23.24	25.19	27.90	21.18	21.21	20.72	22.47	24.90	18.89	18.91	18.22	19.77	21.93	
	S/T‡	1.00	0.97	0.80	0.77	0.55	1.00	1.00	0.81	0.79	0.56	1.00	1.00	0.84	0.81	0.57	1.00	1.00	0.86	0.84	0.58	1.00	1.00	0.90	0.87	0.60	
	AMPS*	7.53	7.52	7.53	7.44	7.33	8.36	8.36	8.36	8.29	8.19	9.31	9.30	9.32	9.25	9.16	10.39	10.39	10.41	10.34	10.25	11.62	11.62	11.65	11.58	11.49	
	HI PR	260	261	260	263	266	301	301	301	304	308	347	347	346	349	353	396	397	396	399	403	451	451	449	452	457	
	LO PR	142	143	143	153	167	145	145	144	155	169	148	148	146	157	171	151	151	148	159	173	155	155	150	161	175	
1080	MBh†	28.95	29.00	28.73	31.12	34.46	26.52	26.56	26.07	28.23	31.26	24.12	24.15	23.48	25.43	28.14	21.74	21.77	20.92	22.67	25.09	19.36	19.39	18.38	19.93	22.06	
	S/T‡	1.00	1.00	0.83	0.80	0.56	1.00	1.00	0.85	0.82	0.57	1.00	1.00	0.87	0.85	0.59	1.00	1.00	0.90	0.88	0.60	1.00	1.00	0.94	0.91	0.62	
	AMPS*	7.66	7.66	7.67	7.58	7.47	8.49	8.49	8.51	8.43	8.33	9.43	9.43	9.47	9.39	9.30	10.52	10.52	10.56	10.49	10.40	11.76	11.75	11.80	11.73	11.64	
	HI PR	261	261	261	263	267	302	303	302	304	308	348	348	347	350	354	398	398	396	399	403	452	452	450	453	457	
	LO PR	146	146	145	155	169	149	149	146	157	171	152	152	148	159	173	155	156	150	161	175	159	159	152	163	177	
† Total capacities are net (I.D blower heat subtracted) system capacities based on 25' line set.																											
If additional tubing length and/or indoor unit is located above outdoor unit, a slight variation in capacity may occur.																											
* System amps are total of indoor and outdoor amps																											
‡ S/T are based on 80 °F db entering air at the indoor coil. For sensible capacities at other than 80 °F db, deduct 835 Btuh per 1000 cfm of indoor coil air from MBhxS/T for each degree below 80 °F, or add 835 Btuh per 1000 cfm of indoor coil air from MBhxS/T for each degree above 80 °F																											
†† At TVA rating indoor condition (75 °F db/ 63 °F wb), All other indoor air temperatures are at 80 °F db																											

Manufacturer reserves the right to change, at any time, specifications and designs without notice and without obligations.

SIZE 48 EXPANDED DATA

CFM		High Stage 48 Size Outdoor With EA*4X61L24A* Indoor Cooling																								
		Outdoor Ambient Temperature - Degrees F, Dry Bulb																								
		75					85					95					105					115				
		Entering Indoor Temperature - Degrees F, Wet Bulb																								
		57	62	63††	67	72	57	62	63††	67	72	57	62	63††	67	72	57	62	63††	67	72	57	62	63††	67	72
1200	MBh†	44.82	47.80	48.78	52.69	58.01	43.25	45.73	46.64	50.38	55.52	41.48	43.41	44.28	47.85	52.75	39.58	40.97	41.77	45.16	49.87	37.62	38.48	39.21	42.45	46.94
	S/T‡	1.00	0.86	0.69	0.66	0.50	1.00	0.87	0.70	0.67	0.50	1.00	0.89	0.71	0.69	0.51	1.00	0.92	0.73	0.70	0.51	1.00	0.95	0.75	0.72	0.52
	AMPS*	13.57	13.65	13.67	13.76	13.87	14.92	14.99	15.02	15.12	15.24	16.48	16.54	16.57	16.68	16.83	18.30	18.35	18.38	18.51	18.68	20.44	20.48	20.51	20.66	20.87
	HI PR	269	271	272	275	278	312	314	315	318	322	359	360	361	365	369	410	412	413	416	421	467	468	469	472	478
	LO PR	119	126	128	138	152	122	128	131	141	154	125	131	133	143	157	129	133	135	146	159	133	136	138	148	162
1300	MBh†	46.19	48.58	49.53	53.45	58.83	44.53	46.44	47.32	51.08	56.24	42.67	44.07	44.88	48.47	53.41	40.69	41.57	42.30	45.72	50.44	38.64	39.04	39.66	42.93	47.44
	S/T‡	1.00	0.88	0.71	0.68	0.50	1.00	0.90	0.72	0.69	0.51	1.00	0.92	0.73	0.71	0.52	1.00	0.95	0.75	0.72	0.52	1.00	0.98	0.77	0.74	0.53
	AMPS*	13.76	13.83	13.85	13.94	14.05	15.12	15.18	15.20	15.30	15.42	16.68	16.73	16.75	16.87	17.01	18.51	18.54	18.57	18.70	18.87	20.66	20.67	20.71	20.84	21.06
	HI PR	270	272	272	275	279	313	315	315	318	323	360	361	362	366	370	412	413	413	417	422	468	469	469	473	478
	LO PR	123	129	131	141	154	126	131	133	143	157	129	133	135	145	159	133	135	137	148	162	137	138	140	150	164
1400	MBh†	47.43	49.27	50.16	54.11	59.51	45.69	47.08	47.89	51.67	56.87	43.76	44.66	45.40	49.00	53.97	41.69	42.13	42.75	46.19	50.92	39.56	40.04	40.05	43.33	47.85
	S/T‡	1.00	0.90	0.72	0.69	0.51	1.00	0.92	0.73	0.71	0.52	1.00	0.95	0.75	0.72	0.52	1.00	0.98	0.77	0.74	0.53	1.00	0.97	0.79	0.76	0.55
	AMPS*	13.96	14.01	14.03	14.12	14.22	15.32	15.36	15.38	15.48	15.59	16.88	16.91	16.93	17.04	17.19	18.71	18.73	18.75	18.87	19.05	20.87	20.89	20.89	21.03	21.24
	HI PR	271	272	273	276	280	314	315	316	319	323	361	362	363	366	371	413	413	414	417	422	470	470	470	474	479
	LO PR	126	131	133	143	156	129	133	135	145	159	133	135	137	147	161	136	138	139	149	163	140	142	141	152	166
1500	MBh†	48.56	49.90	50.71	54.67	60.11	46.75	47.66	48.38	52.17	57.37	44.74	45.22	45.82	49.43	54.40	42.59	42.98	43.13	46.57	51.31	40.39	40.45	40.39	43.67	48.18
	S/T‡	1.00	0.93	0.74	0.71	0.52	1.00	0.95	0.75	0.73	0.53	1.00	0.97	0.77	0.74	0.53	1.00	0.98	0.79	0.76	0.55	1.00	1.00	0.81	0.79	0.56
	AMPS*	14.15	14.19	14.21	14.29	14.39	15.51	15.54	15.56	15.65	15.77	17.08	17.09	17.11	17.23	17.36	18.91	18.93	18.93	19.06	19.23	21.07	21.08	21.07	21.21	21.42
	HI PR	272	273	273	276	280	315	316	316	320	324	362	363	363	367	371	414	414	414	418	423	471	471	471	474	479
	LO PR	129	133	134	145	158	132	135	136	147	160	136	137	138	149	163	139	141	141	151	165	143	144	143	153	168
1600	MBh†	49.59	50.47	51.18	55.15	60.61	47.71	48.21	48.80	52.61	57.81	45.63	46.16	46.19	49.82	54.78	43.41	43.48	43.45	46.90	51.64	41.14	41.20	40.69	43.96	48.46
	S/T‡	1.00	0.95	0.75	0.73	0.53	1.00	0.97	0.77	0.74	0.54	1.00	0.97	0.79	0.76	0.54	1.00	1.00	0.81	0.78	0.56	1.00	1.00	0.83	0.81	0.57
	AMPS*	14.34	14.37	14.38	14.46	14.56	15.70	15.72	15.74	15.83	15.94	17.27	17.29	17.29	17.40	17.54	19.11	19.11	19.11	19.23	19.40	21.27	21.28	21.24	21.40	21.60
	HI PR	273	273	274	277	280	316	317	317	320	324	363	364	364	367	372	415	415	415	419	423	472	472	471	475	480
	LO PR	132	135	136	146	160	135	137	138	148	162	139	140	140	150	164	142	143	142	153	167	146	146	144	155	169
1700	MBh†	50.53	51.03	51.59	55.57	61.01	48.59	48.78	49.17	52.98	58.17	46.44	46.53	46.52	50.14	55.11	44.15	44.22	43.74	47.21	51.91	41.82	41.88	40.93	44.21	48.69
	S/T‡	1.00	0.97	0.77	0.74	0.54	1.00	0.99	0.79	0.76	0.54	1.00	1.00	0.80	0.78	0.55	1.00	1.00	0.83	0.80	0.57	1.00	1.00	0.86	0.83	0.58
	AMPS*	14.53	14.54	14.55	14.64	14.73	15.89	15.90	15.91	16.00	16.11	17.46	17.47	17.46	17.57	17.71	19.30	19.31	19.28	19.41	19.58	21.47	21.47	21.42	21.57	21.78
	HI PR	274	274	274	277	281	317	317	317	320	324	364	364	364	368	372	416	416	416	419	424	473	473	471	475	480
	LO PR	135	136	137	148	161	138	139	139	150	163	141	142	141	152	166	145	145	143	154	168	149	149	145	156	170
† Total capacities are net (I.D blower heat subtracted) system capacities based on 25' line set.																										
If additional tubing length and/or indoor unit is located above outdoor unit, a slight variation in capacity may occur.																										
* System amps are total of indoor and outdoor amps																										
‡ S/T are based on 80 °F db entering air at the indoor coil. For sensible capacities at other than 80 °F db, deduct 835 Btuh per 1000 cfm of indoor coil air from MBhxS/T for each degree below 80 °F, or add 835 Btuh per 1000 cfm of indoor coil air from MBhxS/T for each degree above 80 °F																										
†† At TVA rating indoor condition (75 °F db/ 63 °F wb), All other indoor air temperatures are at 80 °F db																										

Manufacturer reserves the right to change, at any time, specifications and designs without notice and without obligations.

SIZE 48 EXPANDED DATA

		Low Stage 48 Size Outdoor With EA*4X61L24A* Indoor Cooling																								
		Outdoor Ambient Temperature - Degrees F, Dry Bulb																								
		75					85					95					105					115				
		Entering Indoor Temperature - Degrees F, Wet Bulb																								
CFM		57	62	63††	67	72	57	62	63††	67	72	57	62	63††	67	72	57	62	63††	67	72	57	62	63††	67	72
960	MBh†	33.79	35.36	36.13	39.28	43.74	31.12	32.25	32.95	35.88	40.04	28.38	29.07	29.69	32.40	36.25	25.61	25.87	26.40	28.88	32.43	22.85	22.89	23.11	25.39	28.62
	S/T‡	1.00	0.90	0.72	0.69	0.51	1.00	0.92	0.73	0.70	0.51	1.00	0.95	0.75	0.72	0.52	1.00	0.98	0.77	0.74	0.53	1.00	1.00	0.80	0.77	0.54
	AMPS*	9.59	9.53	9.51	9.41	9.27	10.82	10.78	10.76	10.67	10.55	12.21	12.18	12.17	12.08	11.97	13.78	13.77	13.75	13.67	13.57	15.56	15.55	15.55	15.47	15.37
	HI PR	255	256	257	259	262	296	297	298	300	304	341	342	343	346	349	391	391	392	395	399	445	445	446	449	453
	LO PR	128	133	135	145	158	131	135	137	147	160	135	137	139	149	163	139	140	142	152	165	144	144	144	155	168
1010	MBh†	34.44	35.72	36.46	39.65	44.15	31.71	32.57	33.25	36.21	40.41	28.91	29.36	29.94	32.68	36.56	26.08	26.32	26.61	29.12	32.69	23.25	23.30	23.29	25.58	28.83
	S/T‡	1.00	0.92	0.73	0.70	0.51	1.00	0.94	0.74	0.71	0.52	1.00	0.97	0.76	0.73	0.53	1.00	0.98	0.79	0.76	0.54	1.00	1.00	0.82	0.79	0.55
	AMPS*	9.64	9.60	9.58	9.47	9.34	10.88	10.85	10.83	10.73	10.61	12.27	12.25	12.24	12.15	12.04	13.84	13.83	13.83	13.74	13.64	15.62	15.62	15.62	15.54	15.44
	HI PR	255	256	257	259	262	297	297	298	301	304	342	342	343	346	350	392	392	392	395	400	446	446	446	449	454
	LO PR	130	134	136	146	160	133	136	138	148	162	137	138	140	150	164	141	142	143	153	167	146	146	146	156	169
1120	MBh†	35.74	36.44	37.11	40.33	44.91	32.89	33.24	33.81	36.80	41.06	29.97	30.03	30.42	33.19	37.12	27.02	27.07	27.01	29.55	33.16	24.07	24.11	23.62	25.93	29.21
	S/T‡	1.00	0.96	0.75	0.73	0.52	1.00	0.98	0.77	0.74	0.53	1.00	1.00	0.79	0.76	0.54	1.00	1.00	0.82	0.79	0.55	1.00	1.00	0.85	0.82	0.57
	AMPS*	9.77	9.74	9.73	9.62	9.49	11.01	11.00	10.98	10.89	10.77	12.40	12.40	12.40	12.31	12.20	13.98	13.98	13.99	13.90	13.80	15.77	15.76	15.78	15.70	15.60
	HI PR	257	257	258	260	263	298	298	299	301	305	343	343	344	347	350	393	393	393	396	400	447	448	447	450	455
	LO PR	135	137	139	149	162	138	139	140	151	164	141	142	143	153	167	145	146	145	155	169	150	150	148	158	172
1280	MBh†	37.37	38.03	37.84	41.11	45.75	34.37	34.43	34.44	37.49	41.79	31.29	31.34	30.97	33.78	37.74	28.19	28.23	27.47	30.04	33.66	25.09	25.13	24.00	26.35	29.61
	S/T‡	1.00	0.95	0.79	0.76	0.54	1.00	1.00	0.81	0.78	0.55	1.00	1.00	0.83	0.80	0.56	1.00	1.00	0.86	0.83	0.58	1.00	1.00	0.90	0.87	0.60
	AMPS*	9.96	9.94	9.95	9.84	9.71	11.21	11.21	11.21	11.11	11.00	12.61	12.61	12.63	12.54	12.43	14.19	14.19	14.22	14.14	14.04	15.98	15.98	16.03	15.94	15.84
	HI PR	258	258	258	260	263	299	299	299	302	305	345	345	345	347	351	395	395	394	397	401	449	449	448	451	455
	LO PR	141	143	142	152	166	144	144	143	154	167	147	147	145	156	170	151	151	148	158	172	155	156	150	161	174
1440	MBh†	38.75	38.81	38.39	41.71	46.36	35.62	35.67	34.93	38.01	42.31	32.41	32.46	31.39	34.22	38.17	29.17	29.21	27.83	30.43	34.00	25.94	25.98	24.33	26.68	29.88
	S/T‡	1.00	1.00	0.83	0.80	0.56	1.00	1.00	0.85	0.82	0.57	1.00	1.00	0.88	0.85	0.59	1.00	1.00	0.91	0.88	0.60	1.00	1.00	0.95	0.92	0.63
	AMPS*	10.16	10.16	10.18	10.07	9.94	11.42	11.41	11.45	11.35	11.23	12.83	12.83	12.87	12.77	12.67	14.41	14.41	14.46	14.38	14.28	16.21	16.20	16.26	16.18	16.09
	HI PR	259	259	259	261	264	301	301	300	303	306	346	346	345	348	352	396	396	395	398	402	451	451	448	452	456
	LO PR	146	146	144	155	168	149	149	146	156	170	152	152	148	158	172	156	156	150	161	174	160	160	153	163	176
† Total capacities are net (I.D blower heat subtracted) system capacities based on 25' line set.																										
‡ If additional tubing length and/or indoor unit is located above outdoor unit, a slight variation in capacity may occur.																										
* System amps are total of indoor and outdoor amps																										
‡ S/T are based on 80 °F db entering air at the indoor coil. For sensible capacities at other than 80 °F db, deduct 835 Btuh per 1000 cfm of indoor coil air from MBhxS/T for each degree below 80 °F, or add 835 Btuh per 1000 cfm of indoor coil air from MBhxS/T for each degree above 80 °F																										
†† At TVA rating indoor condition (75 °F db/ 63 °F wb), All other indoor air temperatures are at 80 °F db																										

Manufacturer reserves the right to change, at any time, specifications and designs without notice and without obligations.

SIZE 60 EXPANDED DATA

CFM		High Stage 60 Size Outdoor With EA*4X61L24A* Indoor Cooling																								
		Outdoor Ambient Temperature - Degrees F, Dry Bulb																								
		75					85					95					105					115				
		Entering Indoor Temperature - Degrees F, Wet Bulb																								
		57	62	63††	67	72	57	62	63††	67	72	57	62	63††	67	72	57	62	63††	67	72	57	62	63††	67	72
1500	MBh†	52.86	55.69	56.79	61.31	67.55	51.03	53.31	54.36	58.67	64.42	49.08	50.79	51.76	55.83	61.47	46.93	48.06	48.94	52.75	58.04	44.52	45.06	45.81	49.38	54.28
	S/T‡	1.00	0.88	0.70	0.68	0.50	1.00	0.89	0.71	0.69	0.51	1.00	0.91	0.73	0.70	0.51	1.00	0.94	0.74	0.72	0.52	1.00	0.97	0.76	0.74	0.53
	AMPS*	16.57	16.69	16.74	16.94	17.22	18.12	18.22	18.27	18.46	18.71	19.91	19.99	20.03	20.22	20.50	21.97	22.02	22.07	22.26	22.53	24.33	24.36	24.40	24.59	24.87
	HI PR	268	269	270	273	277	310	312	313	316	320	356	358	359	363	368	407	409	409	413	419	463	463	464	468	474
	LO PR	122	128	130	141	154	125	130	132	143	156	128	132	134	145	158	132	135	137	147	161	136	137	139	150	164
1625	MBh†	54.39	56.55	57.59	62.15	68.43	52.47	54.10	55.07	59.42	65.39	50.41	51.51	52.40	56.50	62.16	48.15	48.72	49.48	53.33	58.63	45.60	45.72	46.28	49.84	54.80
	S/T‡	1.00	0.90	0.72	0.69	0.51	1.00	0.92	0.73	0.70	0.52	1.00	0.94	0.75	0.72	0.52	1.00	0.97	0.76	0.74	0.53	1.00	1.00	0.79	0.76	0.54
	AMPS*	16.85	16.94	16.99	17.19	17.47	18.40	18.47	18.51	18.71	18.98	20.19	20.24	20.28	20.47	20.74	22.25	22.27	22.31	22.50	22.78	24.60	24.61	24.64	24.83	25.12
	HI PR	269	270	271	274	278	311	313	313	317	321	358	359	360	363	369	409	409	410	414	420	464	464	465	469	475
	LO PR	126	131	133	143	156	129	133	134	145	158	132	135	136	147	161	135	137	139	149	163	140	140	141	152	166
1750	MBh†	55.76	57.31	58.26	62.85	69.20	53.76	54.80	55.68	60.03	65.95	51.60	52.18	52.92	57.05	62.68	49.24	49.87	49.93	53.79	59.12	46.59	46.66	46.67	50.24	55.14
	S/T‡	1.00	0.93	0.74	0.71	0.52	1.00	0.95	0.75	0.72	0.53	1.00	0.97	0.76	0.74	0.53	1.00	0.97	0.78	0.76	0.54	1.00	1.00	0.81	0.79	0.56
	AMPS*	17.13	17.19	17.23	17.44	17.72	18.67	18.72	18.75	18.95	19.22	20.46	20.49	20.51	20.71	20.98	22.52	22.55	22.55	22.75	23.02	24.87	24.88	24.87	25.07	25.35
	HI PR	270	271	271	274	279	312	313	314	317	322	359	360	360	364	369	410	411	411	415	420	466	466	466	470	475
	LO PR	129	133	134	145	158	132	135	136	147	160	135	137	138	149	163	139	141	141	151	165	143	143	143	153	167
2000	MBh†	58.07	58.62	59.34	63.96	70.34	55.90	56.08	56.62	61.03	67.07	53.58	53.66	53.75	57.88	63.58	51.01	51.09	50.63	54.51	59.85	48.19	48.25	47.24	50.80	55.75
	S/T‡	1.00	0.97	0.77	0.74	0.54	1.00	0.99	0.78	0.76	0.54	1.00	1.00	0.80	0.78	0.55	1.00	1.00	0.83	0.80	0.57	1.00	1.00	0.86	0.83	0.58
	AMPS*	17.65	17.68	17.71	17.92	18.21	19.20	19.21	19.22	19.42	19.70	20.98	20.99	20.98	21.18	21.45	23.04	23.04	23.01	23.22	23.49	25.40	25.40	25.34	25.54	25.83
	HI PR	272	272	272	275	280	314	315	315	319	323	361	361	361	365	370	412	412	412	416	421	468	468	467	471	477
	LO PR	135	136	138	148	162	138	139	139	150	164	141	141	141	152	166	145	145	143	154	168	149	149	145	156	170

† Total capacities are net (I.D blower heat subtracted) system capacities based on 25' line set.
 If additional tubing length and/or indoor unit is located above outdoor unit, a slight variation in capacity may occur.
 * System amps are total of indoor and outdoor amps
 ‡ S/T are based on 80 °F db entering air at the indoor coil. For sensible capacities at other than 80 °F db, deduct 835 Btuh per 1000 cfm of indoor coil air from MBhxS/T for each degree below 80 °F, or add 835 Btuh per 1000 cfm of indoor coil air from MBhxS/T for each degree above 80 °F
 †† At TVA rating indoor condition (75 °F db/ 63 °F wb), All other indoor air temperatures are at 80 °F db

Manufacturer reserves the right to change, at any time, specifications and designs without notice and without obligations.

TCA7: Product Specifications

SIZE 60 EXPANDED DATA

Low Stage 60 Size Outdoor With EA*4X61L24A* Indoor Cooling

Outdoor Ambient Temperature - Degrees F, Dry Bulb

75

85

95

105

115

Entering Indoor Temperature - Degrees F, Wet Bulb

CFM		75					85					95					105					115				
		57	62	63††	67	72	57	62	63††	67	72	57	62	63††	67	72	57	62	63††	67	72	57	62	63††	67	72
1100	MBh†	39.47	41.54	42.47	46.16	51.16	36.39	37.89	38.74	42.12	46.73	33.18	34.11	34.87	37.96	42.18	29.90	30.29	30.92	33.75	37.59	26.63	26.70	27.01	29.56	33.03
	S/T‡	1.00	0.89	0.71	0.68	0.50	1.00	0.91	0.72	0.69	0.51	1.00	0.94	0.74	0.71	0.52	1.00	0.97	0.76	0.73	0.53	1.00	1.00	0.79	0.76	0.54
	AMPS*	11.34	11.27	11.25	11.13	10.97	12.75	12.71	12.68	12.58	12.43	14.35	14.32	14.30	14.20	14.07	16.14	16.13	16.12	16.02	15.90	18.14	18.13	18.14	18.05	17.94
	HI PR	253	255	255	258	261	294	295	296	298	302	339	340	340	343	347	388	388	389	392	396	441	441	441	444	449
	LO PR	126	132	134	144	158	129	134	136	146	160	133	136	138	149	163	138	139	141	152	166	143	143	144	155	169
1225	MBh†	41.11	42.45	43.35	47.06	52.13	37.86	38.70	39.49	42.89	47.56	34.48	34.84	35.50	38.60	42.87	31.05	31.11	31.45	34.28	38.15	27.62	27.67	27.43	29.98	33.47
	S/T‡	1.00	0.93	0.73	0.71	0.52	1.00	0.95	0.75	0.72	0.52	1.00	0.98	0.77	0.74	0.53	1.00	1.00	0.79	0.76	0.54	1.00	1.00	0.83	0.80	0.56
	AMPS*	11.48	11.44	11.42	11.30	11.14	12.90	12.87	12.85	12.74	12.60	14.50	14.49	14.48	14.38	14.24	16.30	16.29	16.29	16.20	16.08	18.32	18.31	18.33	18.23	18.13
	HI PR	255	255	256	258	261	295	296	296	299	303	340	340	341	344	348	389	389	389	392	396	442	442	442	445	449
	LO PR	131	135	137	147	161	134	137	139	149	163	138	139	141	152	166	143	143	144	154	168	148	148	146	157	171
1350	MBh†	42.54	43.25	44.04	47.76	52.88	39.15	39.54	41.92	43.49	48.19	35.63	35.69	36.00	39.11	43.39	32.05	32.10	31.86	34.69	38.57	28.47	28.52	27.77	30.32	33.80
	S/T‡	1.00	0.96	0.76	0.73	0.53	1.00	0.99	1.00	0.75	0.54	1.00	1.00	0.80	0.77	0.55	1.00	1.00	0.82	0.80	0.56	1.00	1.00	0.86	0.83	0.58
	AMPS*	11.63	11.61	11.59	11.46	11.30	13.05	13.04	12.96	12.92	12.77	14.67	14.66	14.66	14.56	14.42	16.47	16.46	16.48	16.38	16.26	18.49	18.48	18.51	18.43	18.31
	HI PR	256	256	257	259	262	296	297	299	300	303	341	341	342	344	348	390	390	390	393	397	443	444	442	446	450
	LO PR	135	137	139	150	164	139	140	147	152	166	143	143	143	154	168	147	147	146	156	170	152	152	148	159	173
1475	MBh†	43.82	44.56	44.62	48.34	53.48	40.29	40.36	40.58	43.99	48.68	36.62	36.68	36.41	39.45	43.67	32.91	32.96	32.20	35.02	38.90	29.16	29.24	28.04	30.58	34.04
	S/T‡	1.00	0.95	0.78	0.75	0.54	1.00	1.00	0.80	0.77	0.55	1.00	1.00	0.82	0.80	0.56	1.00	1.00	0.85	0.83	0.58	1.00	1.00	0.89	0.87	0.60
	AMPS*	11.78	11.76	11.76	11.64	11.48	13.21	13.21	13.21	13.10	12.95	14.83	14.82	14.84	14.72	14.59	16.64	16.63	16.66	16.57	16.45	18.63	18.65	18.70	18.61	18.50
	HI PR	257	257	257	259	262	297	297	298	300	303	342	342	342	345	348	391	391	390	394	398	444	444	443	446	450
	LO PR	140	142	141	152	166	143	143	143	154	168	146	147	145	156	170	151	151	148	158	172	156	156	150	161	175

† Total capacities are net (I.D blower heat subtracted) system capacities based on 25' line set.

If additional tubing length and/or indoor unit is located above outdoor unit, a slight variation in capacity may occur.

* System amps are total of indoor and outdoor amps

‡ S/T are based on 80 °F db entering air at the indoor coil. For sensible capacities at other than 80 °F db, deduct 835 Btuh per 1000 cfm of indoor coil air from MBhxS/T for each degree below 80 °F, or add 835 Btuh per 1000 cfm of indoor coil air from MBhxS/T for each degree above 80 °F

†† At TVA rating indoor condition (75 °F db/ 63 °F wb), All other indoor air temperatures are at 80 °F db

Table 7 – Accessory Usage Guidelines

Accessory	Required for Low Ambient Cooling Applications (17 SEER Product Only) (below 55°F / 12.8°C)‡	Required for Low Ambient Cooling Applications Utilizing UI (below 55°F / 12.8°C)	Required for Long Line Applications* (over 80 ft. / 24.38 m)	Required for Sea Coast Application (within 2 miles/3.22 km)
Crankcase Heater	Yes. Standard on some units	Yes. Standard on some units	Yes. standard on some units	No
Compressor Start Assist Capacitor and Relay	No	No	No	No
Liquid Line Solenoid Valve	No	No	See Long Line Applications Guideline	No
Support Feet	Recommended	Recommended	No	Recommended
Hard Shutoff TXV	Yes (Standard with factory approved indoor unit)	Yes (Standard with factory approved indoor unit)	Yes (Standard with factory approved indoor unit)	Yes (Standard with factory approved indoor unit)
Evaporator Freeze Thermostat	Yes	Standard with Ion® control (no kit required)	No	No
Low-Ambient Pressure Switch	Yes	Standard with Ion® control (no kit required)	No	No
Winter Start Control	Yes	Yes	No	No

‡ Non-communicating thermostat required.

* For tubing line sets between 80 and 200 ft. (24.38 and 60.96 m) and/or 20 ft. (6.09 m) vertical differential, refer to Long Line Applications Guideline.

Table 8 – Accessories

Part Number	Description	Used On Model GKA/B
NASA401LS	Liquid Line Solenoid Valve, R-410A	ALL
NASA001TD	Time Delay Relay, Indoor Blower	ALL
NASA00201SF	Support Feet, 4" (102mm) tall	ALL
NASA012SC	Hard Start Kit (Capacitor & Relay)	24, 36
NASA015SC	Hard Start Kit (Capacitor & Relay)	48, 60
NASA01201CH	Crankcase Heater Kit (Factory installed on 48 & 60)	24, 36
NASA00201FS	Evaporator Freeze Thermostat	ALL
NASA00201WS	Winter Start Control	ALL
NASA401LA	Low Ambient Kit (Pressure Switch) R-410A	ALL
WALL CONTROL		
SYST0101CW	Ion® System Control	ALL