

# COMMERCIAL HIGH-EFFICIENCY CONDENSING UNITS



## RAWL Series

Nominal Sizes 10, 12.5, 15 & 20 Ton  
[44.0, 52.8 & 70.3 kW]

Manufactured for  
**Fujitsu General America, Inc.**  
Fairfield, NJ



## TABLE OF CONTENTS

Standard Unit Features .....	3
Model Number Identification .....	4
Condensing Unit Accessories .....	5
Standard Unit Features .....	6
Gross Capacity and Power Tables .....	7-8
Unit Dimensions .....	9-10
Performance Data .....	11-14
General Installation .....	15
Piping Recommendation .....	16-17
Sequence of Operation .....	18
Guide Specifications .....	19
Limited Warranty .....	20

## STANDARD UNIT FEATURES

- **CABINET**—Galvanized steel with a durable powder paint finish. Stamped louvered panels offer 100% protection for the condenser coil.
- **COMPRESSOR**—The Scroll Compressor is hermetically sealed with internal overload protection and durable insulation on motor windings. The entire compressor is mounted on rubber grommets to reduce vibration and noise.
- **CONDENSER COIL**—Constructed with copper tubes and aluminum fins mechanically bonded to the tubes for maximum heat transfer capabilities.
- **BASE PAN**—Galvanized steel with powder paint finish.
- **REFRIGERANT CONNECTIONS**—Field piping connections are made through a fixed panel. This allows removal of access panels after piping connections have been made.
- **CRANKCASE HEATERS**—Standard, all models. Prevents refrigerant migration to compressor(s).
- **LOW AMBIENT CONTROL**—A pressure sensitive fan cycling control to allow unit operation down to 0°F [-17.8°C] is standard.
- **SERVICE VALVES**—Standard on liquid and suction lines. Allows outdoor section to be isolated from indoor coil.
- **SERVICE ACCESS**—Control box as well as the compressor and other refrigerant controls are accessible through access panels. Control box may be open without affecting the normal operation of the unit. Condenser fan motors are accessible by removing wire grilles.
- **FILTER DRIER**—Standard (uninstalled) on all models. Helps ensure refrigerant cleanliness.
- **TRANSFORMER**—Step-down type, line to 24 volts. Provides control circuit voltage.
- **CONTACTOR**—The contactor is an electrical switch which operates the compressor and condenser fans.
- **HIGH PRESSURE CONTROL**—Opens the contactor circuit on high refrigerant pressure; manual reset.
- **LOW PRESSURE CONTROL**—Stops compressor operation in the event of loss of refrigerant.
- **CONDENSER FAN MOTOR (Direct Drive)**—Ball bearing 1075 RPM motors are mounted to minimize vibration and noise problems. These are permanent split capacitor types.
- **TESTING**—All units are run tested at the factory prior to shipment. Units are shipped with a holding charge of nitrogen.
- **EXTERNAL GAUGE PORTS**—Allows pressures to be checked without removing access panel.
- **COIL LOUVERS**—Helps prevent damage to outdoor coils.
- **TIME DELAY**—Supplied on tandem compressor models to provide a delay between stages.
- **EQUIPMENT GROUND**—Lug for field connection of ground wire.

[ ] Designates Metric Conversions

## WHY USE A HIGH EFFICIENCY, AIR COOLED SPLIT SYSTEM?

- The size ranges offered by Fujitsu allow you to mix or match components to meet actual job requirements, thus eliminating the need to use oversized or undersized equipment. Equipment sized to meet the actual load will provide better operating economy, better humidity control, and longer equipment life.
- With an air cooled system, you have no water or sewer connections to make, and no troublesome and costly water treatment problems.
- Since the condensing unit is located outside the building, and the low profile air handling unit can be installed in the drop ceiling or in the conditioned space, you will not need a separate equipment room which takes up valuable building space.
- Remote mounting of the already quiet condensing unit keeps the compressor and condenser fan noise outside, and the vertical discharge fans carry the sound up and away from the surrounding area.
- Because of the simple design of the condensing unit, installation is quick and simple, and very little maintenance is required.
- Energy Efficiency Ratings (EER's) to 11.2!

## MODEL IDENTIFICATION

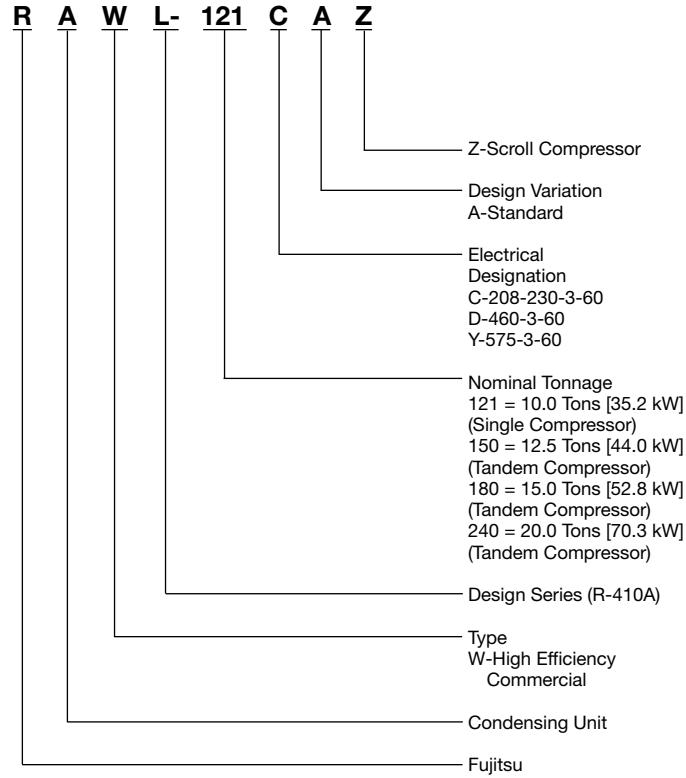

[ ] Designates Metric Conversions

## CONDENSING UNIT ACCESSORIES

ACCESSORY DESCRIPTION	MODEL NUMBER	SIZES USED ON
Sight Glass	RXAG-A048	121
Sight Glass	RXAG-A020	180, 240
Liquid Line Solenoid Valve*	RXAV-CD120	150
Liquid Line Solenoid Valve*	RXAV-CD180	180, 240

\*Cannot be used as a pump down solenoid.

## CONTROL BOX

**RAWL**  
**(-121, -150, -180 & -240)**  
**SHOWN, OTHER TANDEM**  
**COMPRESSOR MODELS**  
**TYPICAL**

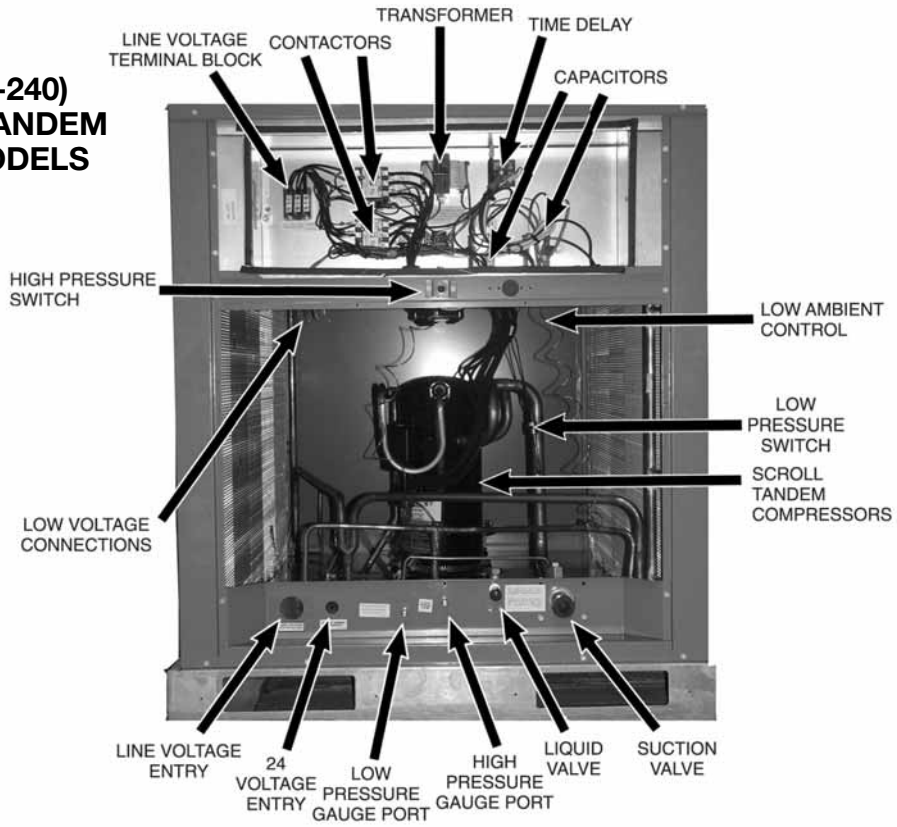

## CONDENSING UNIT – GROSS CAPACITY AND POWER

<b>RAWL-121</b>						
°F [°C] OUTDOOR AMBIENT TEMPERATURE	SATURATED EVAPORATOR TEMPERATURE °F [°C]					
	40 [4.4]		45 [7.2]		50 [10.0]	
	MBH [kW]	KW	MBH [kW]	KW	MBH [kW]	KW
75 [24]	112.3	6.8	122.3	6.9	133.0	7.0
80 [27]	110.3	7.1	120.3	7.3	130.9	7.4
85 [29]	107.9	7.5	117.6	7.6	128.0	7.8
90 [32]	104.5	7.9	114.6	8.0	124.6	8.1
95 [35]	101.3	8.3	110.7	8.4	120.8	8.5
100 [38]	97.4	8.7	106.8	8.8	116.8	8.9
105 [41]	93.5	9.2	102.7	9.2	111.9	9.4
110 [43]	89.3	9.6	98.4	9.7	107.7	9.8
115 [46]	87.0	10.1	94.3	10.2	101.3	10.3

<b>RAWL-150</b>						
°F [°C] OUTDOOR AMBIENT TEMPERATURE	SATURATED EVAPORATOR TEMPERATURE °F [°C]					
	40 [4.4]		45 [7.2]		50 [10.0]	
	MBH [kW]	KW	MBH [kW]	KW	MBH [kW]	KW
75 [24]	151.6 [44.42]	9.5	164.3 [48.13]	9.6	177.2 [51.90]	9.7
80 [27]	147.0 [43.06]	10.0	159.4 [46.69]	10.1	172.0 [50.39]	10.3
85 [29]	142.3 [41.70]	10.6	154.5 [45.26]	10.7	166.8 [48.88]	10.8
90 [32]	137.7 [40.33]	11.1	149.5 [43.82]	11.2	161.7 [47.36]	11.3
95 [35]	133.0 [38.97]	11.6	144.6 [42.38]	11.7	156.5 [45.85]	11.9
100 [38]	128.3 [37.61]	12.1	139.7 [40.94]	12.3	151.3 [44.34]	12.4
105 [41]	123.7 [36.24]	12.7	134.8 [39.50]	12.8	146.2 [42.82]	12.9
110 [43]	119.0 [34.88]	13.2	129.9 [38.07]	13.3	141.0 [41.31]	13.4
115 [46]	114.4 [33.51]	13.7	125.0 [36.63]	13.8	135.8 [39.80]	14.0

KW – Condensing Unit Power (Compressor + Fan)  
 MBH – Gross Capacity x 1000 BTUH [kW]

NOTES: 1. All values at approximately 20°F [11.1°C] subcooling  
 2. Data includes 25 feet [7.62 m] of recommended vapor and liquid lines

[ ] Designates Metric Conversions

## CONDENSING UNIT – GROSS CAPACITY AND POWER (cont.)

RAWL-180						
°F [°C] OUTDOOR AMBIENT TEMPERATURE	SATURATED EVAPORATOR TEMPERATURE °F [°C]					
	40 [4.4]		45 [7.2]		50 [10.0]	
	MBH [kW]	KW	MBH [kW]	KW	MBH [kW]	KW
75 [24]	200.8 [58.84]	11.4	216.3 [63.38]	11.8	222.7 [65.24]	12.2
80 [27]	194.3 [56.94]	12.2	209.8 [61.47]	12.6	217.8 [63.82]	12.9
85 [29]	187.8 [55.03]	13.0	203.3 [59.56]	13.3	213.0 [62.40]	13.7
90 [32]	181.3 [53.12]	13.8	196.7 [57.64]	14.1	208.1 [60.98]	14.5
95 [35]	174.8 [51.22]	14.5	190.2 [55.73]	14.8	203.3 [59.56]	15.2
100 [38]	168.3 [49.31]	15.3	183.7 [53.82]	15.6	198.4 [58.14]	16.0
105 [41]	161.8 [47.40]	16.1	177.1 [51.90]	16.3	193.6 [56.72]	16.7
110 [43]	155.3 [45.50]	16.9	170.6 [49.99]	17.1	188.7 [55.30]	17.5
115 [46]	148.8 [43.59]	17.6	164.1 [48.08]	17.8	183.9 [53.88]	18.2

RAWL-240						
°F [°C] OUTDOOR AMBIENT TEMPERATURE	SATURATED EVAPORATOR TEMPERATURE °F [°C]					
	40 [4.4]		45 [7.2]		50 [10.0]	
	MBH [kW]	KW	MBH [kW]	KW	MBH [kW]	KW
75 [24]	272.7 [79.90]	17.6	294.3 [86.23]	18.0	316.7 [92.79]	18.5
80 [27]	264.1 [77.39]	18.5	285.6 [83.67]	18.9	307.7 [90.14]	19.4
85 [29]	255.6 [74.88]	19.4	276.9 [81.12]	19.9	298.6 [87.50]	20.3
90 [32]	247.0 [72.37]	20.4	268.1 [78.56]	20.8	289.6 [84.86]	21.3
95 [35]	238.5 [69.87]	21.3	259.4 [76.01]	21.7	280.6 [82.22]	22.2
100 [38]	229.9 [67.36]	22.2	250.7 [73.45]	22.6	271.6 [79.58]	23.1
105 [41]	221.3 [64.85]	23.1	242.0 [70.89]	23.5	262.6 [76.94]	24.1
110 [43]	212.8 [62.35]	24.0	233.2 [68.34]	24.4	253.6 [74.29]	25.0
115 [46]	204.2 [59.84]	24.9	224.5 [65.78]	25.3	244.5 [71.65]	25.9

KW – Condensing Unit Power (Compressor + Fan)  
 MBH – Gross Capacity x 1000 BTUH [kW]

NOTES: 1. All values at approximately 20°F [11.1°C] subcooling  
 2. Data includes 25 feet [7.62 m] of recommended vapor and liquid lines

[ ] Designates Metric Conversions



## UNIT DIMENSIONS AND WEIGHTS

MODEL	TOTAL WEIGHT LBS. [kg]	Corner Weights, Lbs. [kg]			
		A	B	C	D
RAWL-121	557 [253]	137 [62]	148 [67]	131 [59]	142 [64]
RAWL-150	650 [295]	160 [72]	171 [78]	154 [70]	165 [75]
RAWL-180	746 [338]	183 [83]	196 [89]	177 [80]	189 [86]
RAWL-240	952 [432]	234 [106]	251 [114]	226 [103]	241 [110]

### 12.5 TON [44 kW]

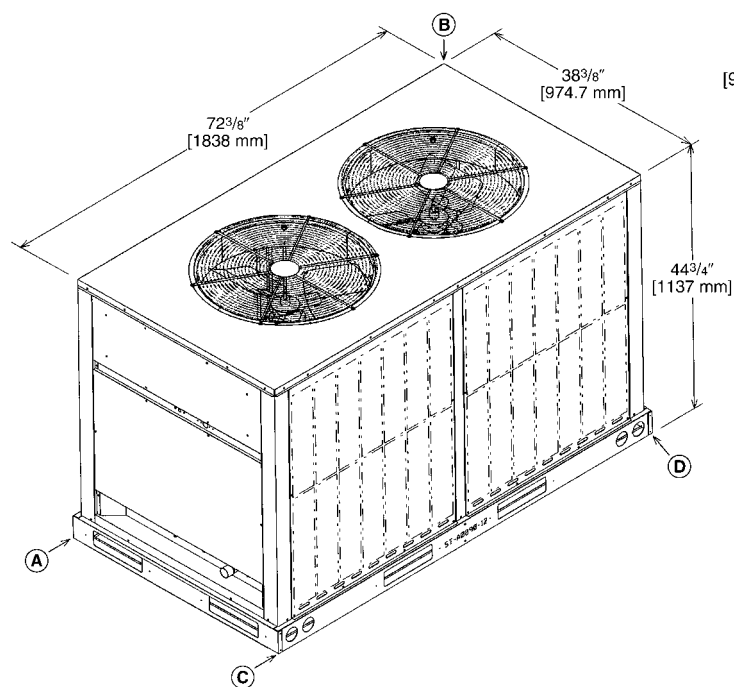

### BOTTOM VIEW

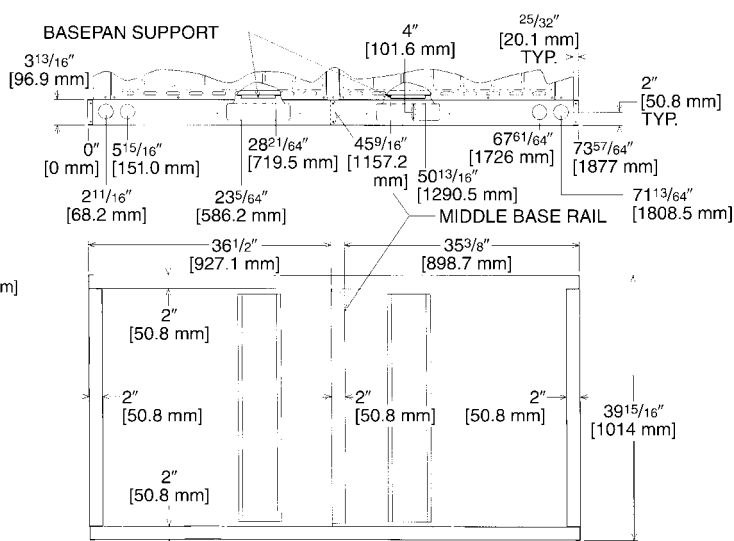

# UNIT DIMENSIONS (cont.)

## 15 TON & 20 TON [52.8 kW & 70.3 kW]

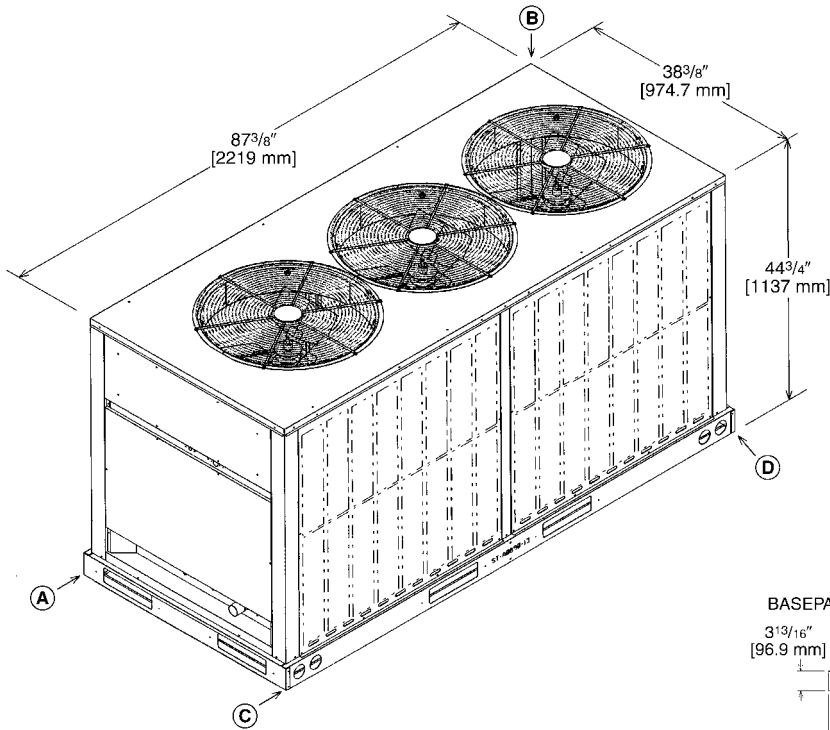

### BOTTOM VIEW

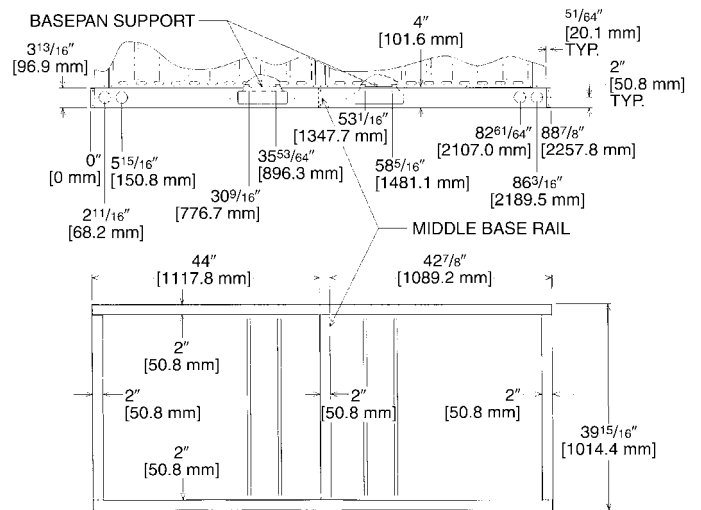

### CONTROL ACCESS SIDE VIEW

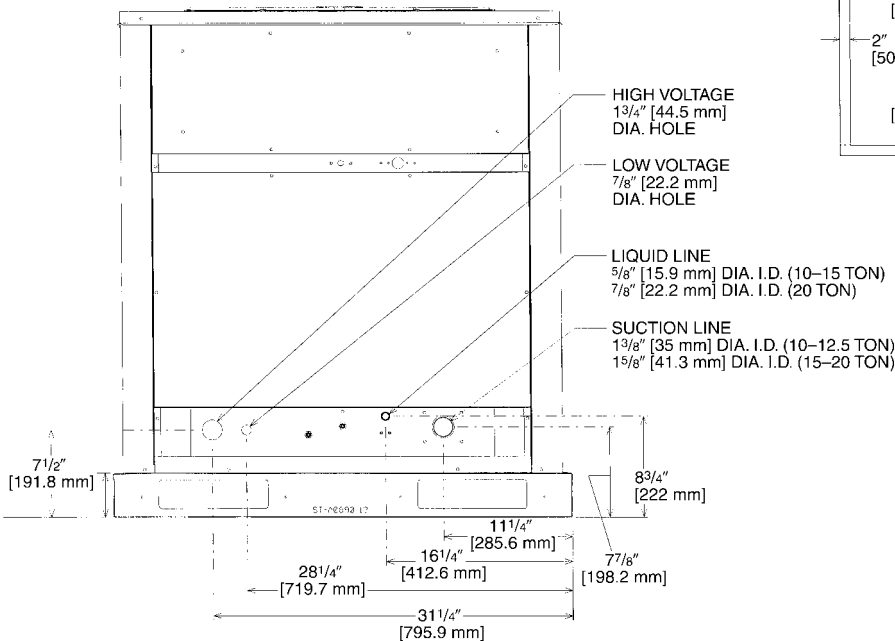

[ ] Designates Metric Conversions

### ALL MODELS

**ELECTRICAL & PHYSICAL DATA: RAWL-**

Model No. RAWL-	ELECTRICAL						PHYSICAL						
	Phase Frequency (Hz) Voltage (Volts)	Compressor		Full Load Amperes (FLA)	Minimum Circuit Ampacity Amperes	Fuse or HACR Circuit Breaker		Outdoor Coil			Refrig. Per Circuit Oz. [g]	Weight	
		Rated Load Amperes (RLA)	Locked Rotor Amperes (LRA)			Minimum Amperes	Maximum Amperes	Face Area Sq. Ft. [Sq. m]	No. Rows	CFM [L/s]		Net Lbs. [kg]	Ship Lbs. [kg]
121CAZ	3-60-208/230	32.6/32.6	240	3.5	44/48	60/60	80/80	32.88 [3.05]	2	8000 [3775]	437 [12389]	557 [253.0]	597 [271.0]
121DAZ	3-60-460	14.8/14.8	130	1.6	26	30	40	32.88 [3.05]	2	8000 [3775]	437 [12389]	557 [253.0]	597 [271.0]
150CAZ	3-60-208/230	22.4/22.4	149	4.8	56/56	70/70	70/70	32.88 [3.05]	2	8000 [3775]	378 [10716]	650 [294.8]	690 [313.0]
150DAZ	3-60-460	10.6	75	2.8	27	30	35	32.88 [3.05]	2	8000 [3775]	378 [10716]	650 [294.8]	690 [313.0]
180CAZ	3-60-208/230	25/25	164	7.2	64/64	70/70	80/80	40.38 [3.75]	2	12000 [5663]	506 [14345]	746 [338.4]	786 [356.5]
180DAZ	3-60-460	12.2	100	4.2	32	35	40	40.38 [3.75]	2	12000 [5663]	506 [14345]	746 [338.4]	786 [356.5]
240CAZ	3-60-208/230	33.3/33.3	239	7.2	83/83	100/100	110/110	40.38 [3.75]	3	12000 [5663]	655 [18569]	952 [431.8]	992 [450.0]
240DAZ	3-60-460	17.9	125	3.3	44	50	60	40.38 [3.75]	3	12000 [5663]	655 [18569]	952 [431.8]	992 [450.0]
240YAZ	3-60-575	12.8	80	2.4	32	35	40	40.38 [3.75]	3	12000 [5663]	655 [18569]	952 [431.8]	992 [450.0]

[ ] Designates Metric Conversions

## PERFORMANCE DATA @ AHRI STANDARD CONDITIONS – COOLING: RAWL-

MODEL NUMBERS		80°F [26.5°C] DB/67°F [19.5°C] WB INDOOR AIR 95°F [35°C] DB OUTDOOR AIR					SOUND RATING dB	INDOOR CFM [L/s]
OUTDOOR UNIT RAWL-	INDOOR COIL AND/OR AIR HANDLER	TOTAL CAPACITY BTU/H [kW]	NET SENSIBLE BTU/H [kW]	NET LATENT BTU/H [kW]	EER	IEER		
121CAZ	RHGN-H120CR ①	113,000 [33.1]	82,100 [24.1]	30,900 [9.1]	11.20	12.9	88	3,735 [1762]
121DAZ	RHGN-H120DR ①	113,000 [33.1]	82,100 [24.1]	30,900 [9.1]	11.20	12.9	88	3,735 [1762]
150CAZ	RHGL-180Z ①	146,000 [42.8]	112,000 [32.8]	34,000 [10.0]	11.10	14.6	88	5,000 [2360]
150DAZ	RHGL-180Z	146,000 [42.8]	112,000 [32.8]	34,000 [10.0]	11.10	14.6	88	5,000 [2360]
180CAZ	RHGL-180Z ①	178,000 [52.2]	125,000 [36.6]	53,000 [15.5]	11.00	13	88	5,100 [2407]
180DAZ	RHGL-180Z	178,000 [52.2]	125,000 [36.6]	53,000 [15.5]	11.00	13	88	5,100 [2407]
240CAZ	RHGL-240Z ①	244,000 [71.5]	169,000 [49.5]	75,000 [22.0]	10.00	12.7	88	6,900 [3256]
240DAZ	RHGL-240Z	244,000 [71.5]	169,000 [49.5]	75,000 [22.0]	10.00	12.7	88	6,900 [3256]
240YAZ	RHGL-240Y	244,000 [71.5]	169,000 [49.5]	75,000 [22.0]	10.00	12.7	88	6,900 [3256]

① Highest sales volume tested combination required by D.O.E. test procedures.  
N/A = Not applicable

[ ] Designates Metric Conversions

# COOLING PERFORMANCE DATA

CONDENSING UNIT **RAWL-150**

WITH COOLING COIL **RHGL-180**

ENTERING INDOOR AIR @ 80°F [26.7°C] dbE ①											
wbE		71°F [21.7°C]			67°F [19.4°C]			63°F [17.2°C]			
CFM [L/s]		6000 [2832]	5000 [2360]	4000 [1888]	6000 [2832]	5000 [2360]	4000 [1888]	6000 [2832]	5000 [2360]	4000 [1888]	
DR ①		.06	.01	.14	.06	.01	.14	.06	.01	.14	
OUTDOOR DRY BULB TEMPERATURE °F [°C]	75 [23.9]	Total BTUH [kW] Sens BTUH [kW] Power	159.8 [46.8] 108.4 [31.8] 10.5	154.2 [45.2] 93.5 [27.4] 10.3	148.6 [43.6] 79.7 [23.4] 10.1	164.1 [48.1] 135.8 [39.8] 11.5	158.3 [46.4] 118.4 [34.7] 11.3	152.6 [44.7] 102.2 [30.0] 11.1	157.5 [46.2] 151.0 [44.3] 12.4	152.0 [44.5] 132.6 [38.9] 12.2	146.5 [42.9] 115.2 [33.8] 12.0
	80 [26.7]	Total BTUH [kW] Sens BTUH [kW] Power	159.9 [46.9] 108.8 [31.9] 11.1	154.3 [45.2] 93.9 [27.5] 10.9	148.7 [43.6] 80.1 [23.5] 10.7	164.2 [48.1] 136.2 [39.9] 12.0	158.4 [46.4] 118.8 [34.8] 11.8	152.7 [44.8] 102.5 [30.0] 11.6	157.7 [46.2] 151.5 [44.4] 13.0	152.1 [44.6] 133.0 [39.0] 12.8	146.6 [43.0] 115.6 [33.9] 12.6
	85 [29.4]	Total BTUH [kW] Sens BTUH [kW] Power	159.0 [46.6] 108.6 [31.8] 11.7	153.5 [45.0] 93.8 [27.5] 11.5	147.9 [43.3] 80.0 [23.5] 11.3	163.3 [47.9] 136.0 [39.9] 12.7	157.6 [46.2] 118.7 [34.8] 12.5	151.9 [44.5] 102.5 [30.0] 12.2	156.8 [46.0] 151.3 [44.4] 13.7	151.3 [44.3] 132.9 [39.0] 13.4	145.8 [42.7] 115.5 [33.9] 13.2
	90 [32.2]	Total BTUH [kW] Sens BTUH [kW] Power	157.2 [46.1] 107.7 [31.6] 12.4	151.7 [44.5] 93.0 [27.3] 12.1	146.1 [42.8] 79.2 [23.2] 11.9	161.4 [47.3] 135.0 [39.6] 13.3	155.8 [45.7] 117.9 [34.6] 13.1	150.1 [44.0] 101.7 [29.8] 12.9	154.9 [45.4] 150.3 [44.1] 14.3	149.5 [43.8] 132.1 [38.7] 14.1	144.0 [42.2] 114.8 [33.7] 13.8
	95 [35]	Total BTUH [kW] Sens BTUH [kW] Power	154.3 [45.2] 106.1 [31.1] 13.1	148.9 [43.6] 91.6 [26.9] 12.8	143.5 [42.1] 78.2 [22.9] 12.6	158.6 [46.5] 133.5 [39.1] 14.0	153.0 [44.8] 116.5 [34.2] 13.8	147.5 [43.2] 100.6 [29.5] 13.5	152.0 [44.5] 148.7 [43.6] 15.0	146.7 [43.0] 130.7 [38.3] 14.8	141.4 [41.4] 113.7 [33.3] 14.5
	100 [37.8]	Total BTUH [kW] Sens BTUH [kW] Power	150.5 [44.1] 103.8 [30.4] 13.8	145.2 [42.6] 89.6 [26.3] 13.5	139.9 [41.0] 76.4 [22.4] 13.3	154.7 [45.3] 131.1 [38.4] 14.8	149.3 [43.8] 114.5 [33.6] 14.5	143.9 [42.2] 98.9 [29.0] 14.3	148.2 [43.4] 146.4 [42.9] 15.7	143.0 [41.9] 128.7 [37.7] 15.5	137.8 [40.4] 112.0 [32.8] 15.2
	105 [40.6]	Total BTUH [kW] Sens BTUH [kW] Power	145.6 [42.7] 100.7 [29.5] 14.6	140.5 [41.2] 87.0 [25.5] 14.3	135.4 [39.7] 74.3 [21.8] 14.1	149.9 [43.9] 128.1 [37.6] 15.5	144.6 [42.4] 111.9 [32.8] 15.3	139.4 [40.9] 96.7 [28.3] 15.0	143.3 [42.0] 143.3 [42.0] 16.5	138.3 [40.5] 126.1 [37.0] 16.2	133.3 [39.1] 109.8 [32.2] 15.9
	110 [43.3]	Total BTUH [kW] Sens BTUH [kW] Power	139.8 [41.0] 97.1 [28.5] 15.4	134.9 [39.5] 83.9 [24.6] 15.1	130.0 [38.1] 71.6 [21.0] 14.8	144.1 [42.2] 124.4 [36.5] 16.4	139.0 [40.7] 108.7 [31.9] 16.1	133.9 [39.2] 93.9 [27.5] 15.8	137.5 [40.3] 137.5 [40.3] 17.3	132.7 [38.9] 123.0 [36.1] 17.0	127.9 [37.5] 107.2 [31.4] 16.7
	115 [46.1]	Total BTUH [kW] Sens BTUH [kW] Power	133.0 [39.0] 92.7 [27.2] 16.2	128.3 [37.6] 80.1 [23.5] 15.9	123.6 [36.2] 68.4 [20.1] 15.7	137.2 [40.2] 119.9 [35.1] 17.2	132.4 [38.8] 104.9 [30.8] 16.9	127.6 [37.4] 90.8 [26.6] 16.6	130.7 [38.3] 130.7 [38.3] 18.2	126.1 [37.0] 119.1 [34.9] 17.9	121.5 [35.6] 103.8 [30.4] 17.6

## CONDENSING UNIT **RAWL-180** WITH COOLING COIL **RHGL-180**

ENTERING INDOOR AIR @ 80°F [26.7°C] dbE ①											
wbE		71°F [21.7°C]			67°F [19.4°C]			63°F [17.2°C]			
CFM [L/s]		6120 [2888]	5100 [2407]	4080 [1926]	6120 [2888]	5100 [2407]	4080 [1926]	6120 [2888]	5100 [2407]	4080 [1926]	
DR ①		.01	.07	.14	.01	.07	.14	.01	.07	.14	
OUTDOOR DRY BULB TEMPERATURE °F [°C]	75 [23.9]	Total BTUH [kW] Sens BTUH [kW] Power	238.4 [69.9] 148.4 [43.5] 15.8	230.0 [67.4] 127.3 [37.3] 15.6	221.6 [64.9] 107.8 [31.6] 15.3	217.6 [63.8] 164.2 [48.1] 14.5	210.0 [61.5] 142.6 [41.8] 14.2	202.4 [59.3] 122.4 [35.9] 14.0	210.9 [61.8] 180.8 [53.0] 13.1	203.5 [59.6] 158.0 [46.3] 12.9	196.1 [57.5] 136.5 [40.0] 12.6
	80 [26.7]	Total BTUH [kW] Sens BTUH [kW] Power	232.3 [68.1] 145.6 [42.7] 16.4	224.1 [65.7] 125.0 [36.6] 16.1	216.0 [63.3] 106.0 [31.1] 15.9	211.5 [62.0] 161.5 [47.3] 15.0	204.1 [59.8] 140.3 [41.1] 14.8	196.7 [57.6] 120.5 [35.3] 14.5	204.8 [60.0] 178.1 [52.2] 13.7	197.6 [57.9] 155.7 [45.6] 13.4	190.4 [55.8] 134.6 [39.5] 13.2
	85 [29.4]	Total BTUH [kW] Sens BTUH [kW] Power	226.4 [66.4] 142.9 [41.9] 17.0	218.5 [64.0] 122.8 [36.0] 16.7	210.5 [61.7] 104.1 [30.5] 16.4	205.7 [60.3] 158.8 [46.5] 15.7	198.5 [58.2] 138.0 [40.5] 15.4	191.2 [56.0] 118.5 [34.7] 15.1	198.9 [58.3] 175.3 [51.4] 14.3	192.0 [56.3] 153.4 [45.0] 14.0	185.0 [54.2] 132.7 [38.9] 13.8
	90 [32.2]	Total BTUH [kW] Sens BTUH [kW] Power	220.8 [64.7] 140.1 [41.1] 17.7	213.0 [62.4] 120.3 [35.3] 17.4	205.3 [60.2] 102.1 [29.9] 17.1	200.0 [58.6] 155.9 [45.7] 16.3	193.0 [56.6] 135.6 [39.8] 16.0	186.0 [54.5] 116.6 [34.2] 15.7	193.3 [56.7] 172.5 [50.6] 14.9	186.5 [54.7] 151.0 [44.3] 14.7	179.7 [52.7] 130.7 [38.3] 14.4
	95 [35]	Total BTUH [kW] Sens BTUH [kW] Power	215.3 [63.1] 137.1 [40.2] 18.4	207.8 [60.9] 117.9 [34.6] 18.1	200.2 [58.7] 100.0 [29.3] 17.7	194.6 [57.0] 153.1 [44.9] 17.0	187.7 [55.0] 133.1 [39.0] 16.7	180.9 [53.0] 114.5 [33.6] 16.4	187.8 [55.0] 169.6 [49.7] 15.6	181.2 [53.1] 148.5 [43.5] 15.4	174.7 [51.2] 128.7 [37.7] 15.1
	100 [37.8]	Total BTUH [kW] Sens BTUH [kW] Power	210.1 [61.6] 134.2 [39.3] 19.1	202.7 [59.4] 115.3 [33.8] 18.8	195.3 [57.2] 97.8 [28.7] 18.4	189.3 [55.5] 150.0 [44.0] 17.7	182.7 [53.5] 130.6 [38.3] 17.4	176.1 [51.6] 112.4 [33.0] 17.1	182.6 [53.5] 166.5 [48.8] 16.4	176.2 [51.6] 145.9 [42.8] 16.1	169.8 [49.8] 126.5 [37.1] 15.8
	105 [40.6]	Total BTUH [kW] Sens BTUH [kW] Power	205.1 [60.1] 131.1 [38.4] 19.9	197.9 [58.0] 112.7 [33.0] 19.5	190.7 [55.9] 95.7 [28.1] 19.2	184.3 [54.0] 146.9 [43.1] 18.5	177.9 [52.1] 128.0 [37.5] 18.2	171.4 [50.2] 110.2 [32.3] 17.9	177.6 [52.0] 163.5 [47.9] 17.1	171.4 [50.2] 143.3 [42.0] 16.8	165.1 [48.4] 124.2 [36.4] 16.5
	110 [43.3]	Total BTUH [kW] Sens BTUH [kW] Power	200.3 [58.7] 127.9 [37.5] 20.7	193.3 [56.7] 110.0 [32.2] 20.3	186.2 [54.6] 93.3 [27.4] 20.0	179.5 [52.6] 143.8 [42.2] 19.3	173.2 [50.8] 125.2 [36.7] 19.0	166.9 [48.9] 107.8 [31.6] 18.6	172.8 [50.6] 160.4 [47.0] 17.9	166.7 [48.9] 140.6 [41.2] 17.6	160.7 [47.1] 122.0 [35.8] 17.3
	115 [46.1]	Total BTUH [kW] Sens BTUH [kW] Power	195.7 [57.4] 124.6 [36.5] 21.5	188.8 [55.3] 107.1 [31.4] 21.1	182.0 [53.3] 90.9 [26.7] 20.8	175.0 [51.3] 140.6 [41.2] 20.1	168.8 [49.5] 122.4 [35.9] 19.8	162.7 [47.7] 105.4 [30.9] 19.4	168.2 [49.3] 157.1 [46.1] 18.8	162.3 [47.6] 137.8 [40.4] 18.4	156.4 [45.8] 119.6 [35.1] 18.1

DR —Depression ratio  
dbE—Entering air dry bulb  
wbE—Entering air wet bulb

Total —Total capacity x 1000 BTUH  
Sens —Sensible capacity x 1000 BTUH  
Power—KW input

**NOTES:**  
① When the entering air dry bulb is other than 80°F [27°C], adjust the sensible capacity from the table by adding [1.10 x CFM x (1 - DR) x (dbE - 80)].  
② Data includes 25 feet [7.62 m] of recommended suction/liquid lines.

[ ] Designates Metric Conversions

# COOLING PERFORMANCE DATA

CONDENSING  
UNIT

RAWL-180

WITH  
AIR  
HANDLER

RHGL-240

ENTERING INDOOR AIR @ 80°F [26.7°C] dbE ①											
wbE		71°F [21.7°C]			67°F [19.4°C]			63°F [17.2°C]			
CFM [L/s]		8040 [3794]	6700 [3162]	5360 [2530]	8040 [3794]	6700 [3162]	5360 [2530]	8040 [3794]	6700 [3162]	5360 [2530]	
DR ①		.06	.01	.13	.06	.01	.13	.06	.01	.13	
OUTDOOR DRY BULB TEMPERATURE °F [°C]	75 [23.9]	Total BTUH [kW] Sens BTUH [kW] Power	251.1 [73.6] 172.1 [50.4] 16.2	242.3 [71.0] 148.6 [43.6] 15.9	233.5 [68.4] 126.8 [37.2] 15.6	230.4 [67.5] 188.1 [55.1] 14.8	222.3 [65.1] 163.9 [48.0] 14.6	214.2 [62.8] 141.3 [41.4] 14.3	223.7 [65.6] 204.7 [60.0] 13.4	215.8 [63.2] 179.3 [52.6] 13.2	208.0 [61.0] 155.5 [45.6] 13.0
	80 [26.7]	Total BTUH [kW] Sens BTUH [kW] Power	245.1 [71.8] 169.5 [49.7] 16.8	236.5 [69.3] 146.4 [42.9] 16.5	227.9 [66.8] 124.9 [36.6] 16.2	224.3 [65.7] 185.3 [54.3] 15.4	216.4 [63.4] 161.6 [47.4] 15.1	208.6 [61.1] 139.4 [40.9] 14.9	217.6 [63.8] 201.9 [59.2] 14.0	209.9 [61.5] 177.0 [51.9] 13.8	202.3 [59.3] 153.6 [45.0] 13.5
	85 [29.4]	Total BTUH [kW] Sens BTUH [kW] Power	239.2 [70.1] 166.7 [48.9] 17.4	230.8 [67.6] 144.1 [42.2] 17.1	222.4 [65.2] 123.0 [36.1] 16.8	218.4 [64.0] 182.5 [53.5] 16.0	210.8 [61.8] 159.3 [46.7] 15.7	203.1 [59.5] 137.4 [40.3] 15.5	211.7 [62.0] 199.1 [58.4] 14.6	204.3 [59.9] 174.7 [51.2] 14.4	196.8 [57.7] 151.6 [44.4] 14.1
	90 [32.2]	Total BTUH [kW] Sens BTUH [kW] Power	233.5 [68.4] 163.8 [48.0] 18.0	225.3 [66.0] 141.6 [41.5] 17.7	217.1 [63.6] 120.9 [35.4] 17.4	212.8 [62.4] 179.7 [52.7] 16.7	205.3 [60.2] 156.9 [46.0] 16.4	197.9 [58.0] 135.5 [39.7] 16.1	206.0 [60.4] 196.3 [57.5] 15.3	198.8 [58.3] 172.3 [50.5] 15.0	191.6 [56.2] 149.7 [43.9] 14.8
	95 [35]	Total BTUH [kW] Sens BTUH [kW] Power	228.1 [66.8] 160.9 [47.2] 18.7	220.1 [64.5] 139.2 [40.8] 18.4	212.1 [62.2] 119.0 [34.9] 18.1	207.3 [60.8] 176.8 [51.8] 17.4	200.1 [58.6] 154.5 [45.3] 17.1	192.8 [56.5] 133.5 [39.1] 16.8	200.6 [58.8] 193.4 [56.7] 16.0	193.6 [56.7] 169.9 [49.8] 15.7	186.5 [54.7] 147.6 [43.3] 15.4
	100 [37.8]	Total BTUH [kW] Sens BTUH [kW] Power	222.9 [65.3] 158.0 [46.3] 19.5	215.0 [63.0] 136.6 [40.0] 19.1	207.2 [60.7] 116.8 [34.2] 18.8	202.1 [59.2] 173.8 [50.9] 18.1	195.0 [57.1] 151.9 [44.5] 17.8	187.9 [55.1] 131.3 [38.5] 17.5	195.4 [57.3] 190.4 [55.8] 16.7	188.5 [55.2] 167.2 [49.0] 16.4	181.7 [53.3] 145.4 [42.6] 16.1
	105 [40.6]	Total BTUH [kW] Sens BTUH [kW] Power	217.8 [63.8] 154.8 [45.4] 20.2	210.2 [61.6] 134.0 [39.3] 19.9	202.6 [59.4] 114.6 [33.6] 19.5	197.1 [57.8] 170.8 [50.1] 18.9	190.2 [55.7] 149.3 [43.8] 18.5	183.3 [53.7] 129.1 [37.8] 18.2	190.4 [55.8] 187.3 [54.9] 17.5	183.7 [53.8] 164.6 [48.2] 17.2	177.0 [51.9] 143.2 [42.0] 16.9
	110 [43.3]	Total BTUH [kW] Sens BTUH [kW] Power	213.1 [62.5] 151.8 [44.5] 21.0	205.6 [60.3] 131.3 [38.5] 20.7	198.1 [58.1] 112.2 [32.9] 20.3	192.3 [56.4] 167.6 [49.1] 19.7	185.6 [54.4] 146.6 [43.0] 19.3	178.8 [52.4] 126.8 [37.2] 19.0	185.6 [54.4] 184.2 [54.0] 18.3	179.1 [52.5] 162.0 [47.5] 18.0	172.6 [50.6] 141.0 [41.3] 17.6
	115 [46.1]	Total BTUH [kW] Sens BTUH [kW] Power	208.5 [61.1] 148.5 [43.5] 21.9	201.2 [59.0] 128.5 [37.7] 21.5	193.8 [56.8] 109.8 [32.2] 21.1	187.7 [55.0] 164.3 [48.2] 20.5	181.2 [53.1] 143.8 [42.2] 20.1	174.6 [51.2] 124.4 [36.5] 19.8	181.0 [53.0] 180.9 [53.0] 19.1	174.6 [51.2] 159.1 [46.6] 18.8	168.3 [49.3] 138.5 [40.6] 18.4

CONDENSING  
UNIT

RAWL-240

WITH  
AIR  
HANDLER

RHGL-240

ENTERING INDOOR AIR @ 80°F [26.7°C] dbE ①											
wbE		71°F [21.7°C]			67°F [19.4°C]			63°F [17.2°C]			
CFM [L/s]		8640 [4078]	7200 [3398]	5760 [2718]	8640 [4078]	7200 [3398]	5760 [2718]	8640 [4078]	7200 [3398]	5760 [2718]	
DR ①		.0	.01	.07	.0	.01	.07	.0	.01	.07	
OUTDOOR DRY BULB TEMPERATURE °F [°C]	75 [23.9]	Total BTUH [kW] Sens BTUH [kW] Power	299.6 [87.8] 198.4 [58.2] 17.9	289.1 [84.7] 171.0 [50.1] 17.6	278.6 [81.6] 145.5 [42.7] 17.3	286.3 [83.9] 229.1 [67.2] 17.5	276.3 [81.0] 199.5 [58.5] 17.2	266.2 [78.0] 171.7 [50.3] 16.9	278.9 [81.7] 260.1 [76.2] 17.1	269.2 [78.9] 228.2 [66.9] 16.8	259.4 [76.0] 198.0 [58.0] 16.5
	80 [26.7]	Total BTUH [kW] Sens BTUH [kW] Power	292.6 [85.8] 194.7 [57.1] 18.9	282.3 [82.7] 167.8 [49.2] 18.6	272.0 [79.7] 142.8 [41.9] 18.3	279.3 [81.9] 225.3 [66.0] 18.5	269.5 [79.0] 196.3 [57.5] 18.2	259.7 [76.1] 169.1 [49.6] 17.8	271.9 [79.7] 256.4 [75.2] 18.1	262.4 [76.9] 225.0 [66.0] 17.7	252.8 [74.1] 195.3 [57.2] 17.4
	85 [29.4]	Total BTUH [kW] Sens BTUH [kW] Power	285.4 [83.6] 191.0 [56.0] 20.0	275.4 [80.7] 164.7 [48.3] 19.6	265.4 [77.8] 140.3 [41.1] 19.3	272.2 [79.8] 221.7 [65.0] 19.6	262.6 [77.0] 193.2 [56.6] 19.2	253.1 [74.2] 166.6 [48.8] 18.9	264.8 [77.6] 252.8 [74.1] 19.1	255.5 [74.9] 221.9 [65.0] 18.8	246.2 [72.2] 192.8 [56.5] 18.5
	90 [32.2]	Total BTUH [kW] Sens BTUH [kW] Power	278.1 [81.5] 187.3 [54.9] 20.8	268.3 [78.6] 161.5 [47.3] 20.8	258.6 [75.8] 137.6 [40.3] 20.4	264.8 [77.6] 217.9 [63.9] 20.7	255.5 [74.9] 190.0 [55.7] 20.3	246.2 [72.2] 163.8 [48.0] 20.0	257.4 [75.4] 249.0 [73.0] 20.3	248.4 [72.8] 218.7 [64.1] 19.9	239.4 [70.2] 190.1 [55.7] 19.6
	95 [35]	Total BTUH [kW] Sens BTUH [kW] Power	270.6 [79.3] 183.6 [53.8] 22.3	261.1 [76.5] 158.4 [46.4] 21.9	251.6 [73.7] 135.0 [39.6] 21.5	257.3 [75.4] 214.2 [62.8] 21.9	248.3 [72.8] 186.9 [54.8] 21.5	239.3 [70.1] 161.3 [47.3] 21.1	249.9 [73.2] 245.2 [71.9] 21.5	241.2 [70.7] 215.6 [63.2] 21.1	232.4 [68.1] 187.5 [55.0] 20.7
	100 [37.8]	Total BTUH [kW] Sens BTUH [kW] Power	262.9 [77.0] 179.7 [52.7] 23.6	253.7 [74.4] 155.2 [45.5] 23.2	244.5 [71.7] 132.4 [38.8] 22.8	249.7 [73.2] 210.5 [61.7] 23.2	240.9 [70.6] 183.7 [53.8] 22.8	232.2 [68.1] 158.7 [46.5] 22.4	242.3 [71.0] 241.5 [70.8] 22.7	233.8 [68.5] 212.4 [62.3] 22.3	225.3 [66.0] 184.9 [54.2] 21.9
	105 [40.6]	Total BTUH [kW] Sens BTUH [kW] Power	255.1 [74.8] 176.1 [51.6] 24.9	246.2 [72.2] 152.2 [44.6] 24.5	237.2 [69.5] 129.8 [38.1] 24.1	241.9 [70.9] 206.9 [60.6] 24.5	233.4 [68.4] 180.7 [53.0] 24.1	224.9 [65.9] 156.1 [45.8] 23.6	234.5 [68.7] 234.5 [68.7] 24.1	226.3 [66.3] 209.4 [61.4] 23.6	218.0 [63.9] 182.3 [53.4] 23.2
	110 [43.3]	Total BTUH [kW] Sens BTUH [kW] Power	247.1 [72.4] 172.4 [50.5] 26.3	238.5 [69.9] 149.1 [43.7] 25.9	229.8 [67.3] 127.3 [37.3] 25.4	233.9 [68.5] 203.1 [59.5] 25.9	225.7 [66.1] 177.6 [52.1] 25.4	217.5 [63.7] 153.6 [45.0] 25.0	226.5 [66.4] 226.5 [66.4] 25.5	218.6 [64.1] 206.2 [60.4] 25.0	210.6 [61.7] 179.7 [52.7] 24.6
	115 [46.1]	Total BTUH [kW] Sens BTUH [kW] Power	239.0 [70.0] 168.7 [49.5] 27.8	230.6 [67.6] 145.9 [42.8] 27.3	222.2 [65.1] 124.7 [36.6] 26.8	225.8 [66.2] 199.4 [58.4] 27.3	217.9 [63.9] 174.5 [51.2] 26.9	209.9 [61.5] 151.0 [44.3] 26.4	218.4 [64.0] 218.4 [64.0] 26.9	210.7 [61.8] 203.1 [59.5] 26.5	203.1 [59.5] 177.3 [52.0] 26.0

DR —Depression ratio  
dbE —Entering air dry bulb  
wbE—Entering air wet bulb

Total —Total capacity x 1000 BTUH  
Sens —Sensible capacity x 1000 BTUH  
Power—KW input

**NOTES:**

- ① When the entering air dry bulb is other than 80°F [27°C], adjust the sensible capacity from the table by adding [1.10 x CFM x (1 - DR) x (dbE - 80)].
- ② Data includes 25 feet [7.62 m] of recommended suction/liquid lines.

[ ] Designates Metric Conversions

## RIGGING

### ROOFTOP INSTALLATION

If rooftop installation is required, make certain that the building construction is adequate for the weight of the unit. (Refer to physical data chart.) Before placing the unit on the roof, make certain that the nylon rigging slings are of sufficient length to maintain equilibrium of the unit when lifting. Under no circumstances should the unit be lifted by only one corner for rooftop installation.

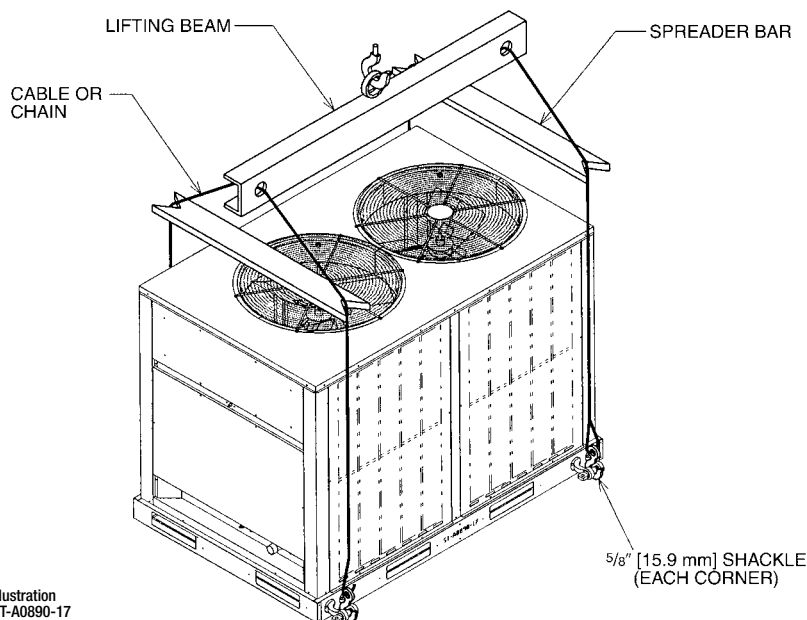

Illustration  
ST-A0890-17

## GENERAL INSTALLATION

The condensing unit should be installed outdoors. It should be located as near as possible to the evaporator section to keep connecting refrigerant tubing lengths to a minimum. The unit must be installed to allow a free air flow to the condenser coils.

If several units are installed adjacent to each other, care must be taken to avoid recirculation of air from one condenser to another. In all installations, adequate space must be provided for installation and servicing.

### CLEARANCES

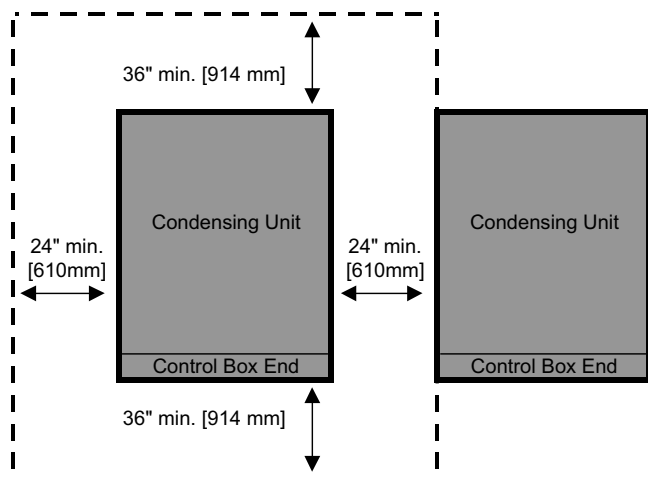

## SLAB INSTALLATION

Condensing units should be set on a solid level foundation. When installed at ground level, the unit should be placed on a cement slab. If the pad is formed at the installation site, do not pour the pad tight against the structure, otherwise vibration will be transmitted from the unit through the pad.

The unit must not be connected to any duct work. Do not locate unit under a roof drip; if necessary, install gutters, etc., to prevent water run-off from hitting the unit. To prevent air recirculation, it is recommended that the unit not be installed under an overhang, but if necessary **allow a minimum of 60 inches [1524 mm] above the unit for air discharge.**

[ ] Designates Metric Conversions

EQUIVALENT LENGTH (FT.) [m] OF STRAIGHT TYPE "L" TUBING FOR NON-FERROUS VALVES & FITTINGS (BRAZED)						
TUBE SIZE, INCHES [mm] O.D.	SOLENOID VALVE	ANGLE VALVE	SHORT RADIUS ELL	LONG RADIUS ELL	TEE LINE FLOW	TEE BRANCH FLOW
5/8 [16.00]	15 [4.6]	10.4 [3.2]	1.9 [0.6]	1.2 [0.4]	1.2 [0.4]	3.6 [1.1]
3/4 [19.00]	18 [5.5]	12.5 [3.8]	2.1 [0.7]	1.4 [0.4]	1.4 [0.4]	4.2 [1.3]
7/8 [22.00]	21 [6.4]	14.6 [4.4]	2.4 [0.7]	1.6 [0.5]	1.6 [0.5]	4.8 [1.5]
1 1/8 [29.00]	12 [3.7]	18.8 [5.7]	3.0 [0.9]	2.0 [0.6]	2.0 [0.6]	6.0 [1.8]
1 3/8 [35.00]	15 [4.6]	22.9 [7.0]	3.6 [1.1]	2.4 [0.7]	2.4 [0.7]	7.2 [2.2]
1 5/8 [41.00]	18 [5.5]	27.1 [8.3]	4.2 [1.3]	2.8 [0.8]	2.8 [0.8]	8.4 [2.6]
2 5/8 [54.00]	21 [6.4]	35.4 [10.8]	5.3 [1.6]	3.5 [1.1]	3.5 [1.1]	10.7 [3.3]

EQUIVALENT LENGTH TO EVAPORATOR (FT.) [m]	RECOMMENDED VAPOR AND LIQUID LINE SIZES TO VARIOUS LENGTH OF RUN					
	LIQUID LINE O.D. (IN.) [mm]			VAPOR LINE O.D. (IN.) [mm]		
	COOLING MODEL			COOLING MODEL		
	150	180	240	150	180	240
1-15 [1-4.57]	5/8 [15.9]	5/8 [15.9]	7/8 [22.2]	1 3/8 [34.9]	1 5/8 [41.3]	1 5/8 [41.3]
16-50 [4.88-15.24]	5/8 [15.9]	5/8 [15.9]	7/8 [22.2]	1 5/8 [41.3]	1 5/8 [41.3]	1 5/8 [41.3]
51-100 [15.54-30.48]	5/8 [15.9]	3/4 [19.1]	7/8 [22.2]	1 5/8 [41.3]	1 5/8 [41.3]	2 1/8 [53.9]
101-150 [30.78-45.72]	5/8 [15.9]	3/4 [19.1]	7/8 [22.2]	2 1/8 [53.9]	2 1/8 [53.9]	2 1/8 [53.9]

**NOTE:** Runs between condenser and evaporator not to exceed an equivalent length greater than 150 [45.7 m] feet.

**LIQUID LINE PRESSURE DROP PER 100 FEET [30.48 m] EQUIVALENT LENGTH (TYPE L COPPER TUBING)**

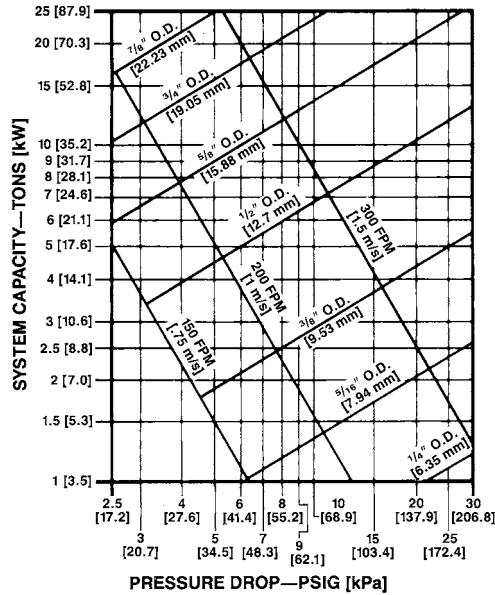

**NOTES:**

- 1) When evaporator coil is above condenser, the pressure drop due to vertical lift (.5 PSIG per foot of lift) [1.05 kPa per meter] **must** be added to the pressure drop derived from this curve.
- 2) Size liquid line for **no more** than 10°F [5.6°C] loss (approximately 50 PSIG [206.8 kPa] total pressure drop).
- 3) **Do not oversize liquid line.** Oversized liquid lines add significantly to the amount of refrigerant required to charge the system.
- 4) The maximum recommended velocity with solenoid valves or other quick closing devices in the liquid line is 300 FPM [1.5 m/s].

[ ] Designates Metric Conversions

**VAPOR LINE SYSTEM CAPACITY LOSS IN PERCENT PER 100 FEET [30.48 m] EQUIVALENT LENGTH (TYPE L COPPER TUBING)**

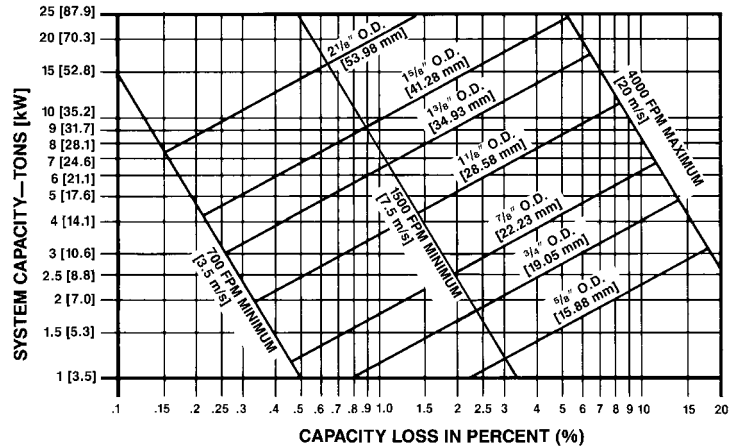

**NOTES:**

- 1) The minimum velocity line (700 fpm) [3.6 m/s] is recommended.
- 2) For vapor pressure drop (PSIG) [6.9 kPa], multiply percent (%) loss by 1.18.
- 3) Size vapor lines for no more than 2°F [1.1°C] loss which corresponds to approximately 5 PSIG [20.7 kPa] pressure drop.
- 4) Pitch all horizontal vapor lines downward in the direction of flow (1/2" [12.7 mm] to 10' [3.0 m] run).

**WARNING**

**Do not use oxygen to purge lines or pressure system for leak test. Oxygen reacts violently with oil, which can cause an explosion resulting in severe personal injury or death.**



## TYPICAL REFRIGERANT PIPING RECOMMENDATIONS (cont.)

### COIL ABOVE CONDENSING UNIT

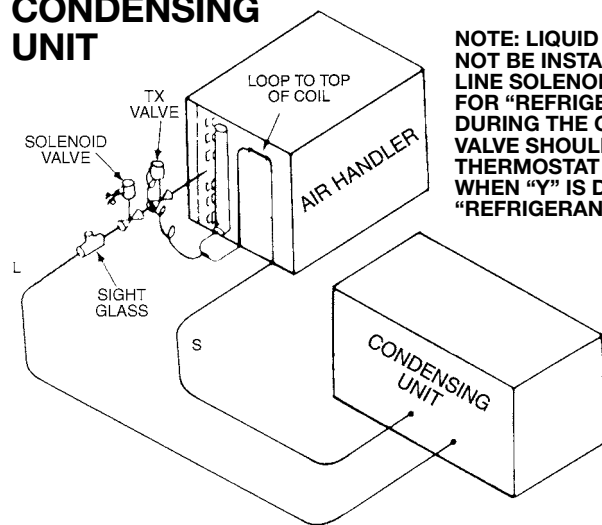

**NOTE: LIQUID LINE SOLENOID VALVE MUST NOT BE INSTALLED FOR PUMP DOWN. LIQUID LINE SOLENOID VALVE MAY BE INSTALLED FOR "REFRIGERANT ISOLATION" ONLY DURING THE OFF-CYCLE. THE SOLENOID VALVE SHOULD BE CLOSED WHEN THE THERMOSTAT IS SATISFIED (VALVE CLOSED WHEN "Y" IS DE-ENERGIZED) FOR EFFECTIVE "REFRIGERANT ISOLATION".**

#### REQUIRED OZS. [g] R410A CHARGE PER FT. [m] OF TUBING

TUBE SIZE O.D. (IN.) [mm]	LIQUID (OZ.) [g]	VAPOR (OZ.) [g]
1/2 [12.7]	1.06 [30.0]	.04 [1.13]
5/8 [15.88]	1.65 [46.7]	.07 [1.98]
3/4 [19.05]	2.46 [69.7]	.10 [2.83]
7/8 [22.23]	3.28 [92.9]	.13 [3.68]
1 1/8 [28.58]		.22 [6.23]
1 3/8 [34.93]		.34 [9.63]
1 5/8 [41.28]		.48 [13.60]
2 1/8 [53.98]		.84 [23.81]

Quantities based on 110°F liquid and 45°F vapor.

#### BASIC SYSTEM CHARGE\*

RAWL-121	RAWL-150	RAWL-180	RAWL-240
437 oz. [12389 g]	378 oz. [10716 g]	506 oz. [14345 g]	655 oz. [18569 g]

\*System with 0 feet [m] of tubing.

[ ] Designates Metric Conversions

## SEQUENCE OF OPERATION RAWL-121, Two Speed

1. When the room thermostat is set on “Cool”, “Fan Auto”, and the temperature is higher than the thermostat setting, the thermostat “Y1” circuit closes and energizes the first speed of the compressor by energizing compressor contactor (CC1). Power to the crankcase heater (CCH) will be de-energized by the auxiliary contacts (AUX).
2. Simultaneously, the “G” circuit provides power to the indoor blower motor circuit and starts indoor air circulation through the evaporator coil.
3. When the discharge pressure increases to 450 psig, the contacts on the low ambient control (LAC) will allow supply power to start the outdoor fan motors (ODF) which begins to pull air through the condenser coils. The system is now in the first stage cooling, operating at near sixty percent of full load capacity.
4. If the temperature at the thermostat continues to increase, the thermostat “Y2” circuit closes and energizes the both speeds of the compressor which is now full load capacity.
5. The system will continue cooling at maximum capacity, as long as the room thermostat is demanding full load and all safety device contacts are closed. The low ambient control (LAC) will open and close, allowing the outdoor fans to maintain discharge pressure between 250 and 450 psig.
6. As the temperature at the thermostat drops enough to satisfy “Y2”, the circuit will open and de-energize the second compressor speed and continues operating on the first speed of the compressor.
7. When continued cooling satisfies the “Y1” circuit, it will open and de-energize the compressor contactor (CC1), stopping the compressor operation and closing the auxiliary contacts (AUX), which energizes the crankcase heater (CH).
8. The thermostat “G” circuit will stop blower operation.

## SEQUENCE OF OPERATION RAWL-150, 180, 240, Two Stage

1. When the room thermostat is set on “Cool”, “Fan Auto”, and the temperature is higher than the thermostat setting, the thermostat “Y1” circuit closes and energizes the number one compressor contactor (CC1) through the closed cooling relay (R) contacts. Power to the crankcase heater (CCH1) will be de-energized by the auxiliary contacts (AUX-1).
2. Simultaneously, the “G” circuit provides power to the indoor blower motor circuit and starts indoor air circulation through the evaporator coil.
3. When the discharge pressure increases to 450 psig, the contacts on the low ambient control (LAC) will allow supply power to start the outdoor fan motors (ODF) which begin to pull air through the condenser coils. The system is now in first stage cooling, operating at near fifty percent of full load capacity.
4. If the temperature at the thermostat continues to increase, the thermostat “Y2” circuit closes and after a 30 second delay, power passes through the time delay control (TDC) and energizes the number two compressor contactor (CC2) through the second set of closed cooling relay (R) contacts. Power to the crankcase heater (CCH2) will be de-energized by the auxiliary contacts (AUX-2).
5. The system will continue cooling at maximum capacity, as long as the room thermostat is demanding full load and all safety device contacts are closed. The low ambient control (LAC) will open and close, allowing the outdoor fans to maintain discharge pressure between 250 and 450 psig.
6. As the temperature at the thermostat drops enough to satisfy “Y2”, the circuit will open and de-energize the compressor contactor (CC2), stopping compressor operation and closing the auxiliary contacts (AUX-2), which energizes the crankcase heater (CCH2).
7. When continued cooling satisfies the “Y1” circuit, it will open and de-energize the compressor contactor (CC1), stopping compressor operation and closing the auxiliary contacts (AUX-1), which energizes the crankcase heater (CCH1).
8. The thermostat “G” circuit will stop blower operation.

[ ] Designates Metric Conversions

## SAMPLE SPECIFICATIONS

Furnish and install as shown on the drawing Fujitsu Model \_\_\_\_\_ air cooled condensing unit suitable for outdoor application.

**COMPRESSOR**—Unit shall have scroll compressor(s). It shall be externally mounted on rubber grommets to reduce vibration transmission and noise to surrounding area. Maximum power input shall not be more than \_\_\_\_\_ at conditions specified.

**LOW AMBIENT CONTROL**—All units shall have standard head pressure controls that cycle the condenser fan motors to maintain condensing pressures for operation down to 0°F [-17.8°C] ambient (12.5 and 15 ton [44.0 and 52.8 kW] models only.)

**CAPACITY**—Capacity shall be \_\_\_\_\_ BTU/H when operating at \_\_\_\_\_ °F [°C] saturated suction temperature.

**MOTORS & FANS**—Each unit shall have 1075 RPM sleeve bearing, permanently lubricated motor(s) fixed with direct-drive, dual bladed fan(s). Motor(s) shall be equipped with inherent overload protection. Motor(s) & fan(s) shall be mounted on top panel for easy access. Condenser air shall discharge vertically.

**COILS**—Coils shall be fabricated of 3/8" [9.53 mm] O.D. seamless copper tubing and aluminum fins with die-formed collars mechanically bonded to tubes arranged in a staggered pattern. All coils shall be submitted to a pressure test after fabrication and dehydrated. Units shall be shipped with a dry nitrogen holding charge. Airflow shall be drawn through design providing uniform air distribution across the coil surface.

[ ] Designates Metric Conversions

**CASINGS**—Casings shall make unit suitable for outdoor installation. Casing, base pan and framework shall be manufactured of galvanized sheet metal subjected to multistage cleaning, primed, and finished with a durable powder coat paint, capable of withstanding a 1000-HR salt spray test per ASTM B 117. Units shall have stamped louver panels offering 100% protection of the condenser coil. Openings shall be provided for power. Dimensions of entire assembly shall be not more than \_\_\_\_\_ inches [mm] high, \_\_\_\_\_ inches [mm] long and \_\_\_\_\_ inches [mm] wide.

**REFRIGERATION CIRCUIT**—Shall include the compressor, the condenser coils, all internal refrigerant piping and liquid and suction line service valves. Refrigerant stubs shall be extended through the cabinet for external field connection without affecting accessibility to compressor compartment.

**CONTROL PANEL**—The panel shall be designed for single power source to the compressor and fan motor(s) and shall include fan cycling control, and compressor contactor.

**SAFETY CONTROLS**—Manual reset high pressure and automatic reset low pressure control shall be provided.

**FACTORY TESTING**—All units shall be test run at the factory.

**GENERAL TERMS OF LIMITED WARRANTY\***

*Fujitsu General America, Inc.* will furnish a replacement for any part of this product which fails in normal use and service within the applicable periods stated, in accordance with the terms of the limited warranty.

Compressor .....Five (5) Years  
Any Other Part .....One (1) Year

**\*For Complete Details of the Limited Warranty, Including Applicable Terms and Conditions, See Your Local Installer or Contact the Manufacturer for a Copy.**







---

**Before proceeding with installation, refer to installation instructions packaged with each model, as well as complying with all Federal, State, Provincial, and Local codes, regulations, and practices.**

---

*"In keeping with its policy of continuous progress and product improvement, the right is reserved to make changes without notice."*