

# COMMERCIAL HIGH-EFFICIENCY CONDENSING UNITS



## RAWL High-Efficiency Series

Nominal Sizes 6.5 & 7.5 Ton  
[22.86 & 26.38 kW]

Manufactured for  
**Fujitsu General America, Inc.**  
Fairfield, NJ



## TABLE OF CONTENTS

Features & Benefits .....	3-5
Model Number Identification .....	6
Physical Data/Electrical Data.....	7
Condensing Unit Accessories/Selection Procedure .....	8
Gross Capacity and Power Tables.....	9
Unit Dimensions.....	10
Clearances.....	11
AHRI Ratings .....	12
Performance Data .....	13-15
Piping and Installation .....	16-17
Guide Specifications .....	18
Limited Warranty .....	19

## Standard Features

- New composite base pan – dampens sound, captures louver panels, eliminates corrosion and reduces number of fasteners needed
- Powder coat paint system – for a long lasting professional finish
- Scroll compressor – uses 70% fewer moving parts for higher efficiency and increased reliability
- Modern cabinet aesthetics – increased curb appeal with visually appealing design
- Curved louver panels – provide ultimate coil protection, enhance cabinet strength, and increased cabinet rigidity
- Optimized fan orifice – optimizes airflow and reduces unit sound
- Rust resistant screws – confirmed through 1500-hour salt spray testing
- Expanded Valve Space – 3"-4"-5" service valve space – provides a minimum working area of 27-square inches for easier access
- Triple Service Access – 15" wide, industry leading corner service access – makes repairs easier and faster. The two fastener removable corner allows optimal access to internal unit components. Individual louver panels come out once fastener is removed, for faster coil cleaning and easier cabinet reassembly
- Diagnostic service window with two-fastener opening – provides access to the high and low pressure.
- External gauge port access – allows easy connection of “low-loss” gauge ports
- 35% fewer cabinet fasteners and fastener-free base – allow for faster access to internal components and hassle-free panel removal
- Service trays – hold fasteners or caps during service calls
- QR code – provides technical information on demand for faster service calls
- Fan motor harness with extra long wires allows unit top to be removed without disconnecting fan wire.
- Low ambient control – a pressure sensitive fan cycling control allows operation of units down to 0°F [-18°C].
- High pressure control – manual reset control deactivates system if abnormally high pressure occurs.
- Low pressure control – automatic reset control deactivates system if abnormally low pressure or refrigerant loss occurs.
- Service valves – standard on liquid and suction lines.
- Condenser fan motors – direct drive, single-phase permanently lubricated ECM motors with inherent overload protection.
- Transformer – 50VA step-down type, from Line to 24 volts.
- Contactor – the contactor is an electrical switch which operates the compressor and condenser fans. Its 24 volt coil is activated through the High Pressure Control and Low Pressure Control on a call for cooling.
- Equipment ground – lug for field connection of ground wire.
- Testing – all units are run tested at the factory prior to shipment. Units are shipped with a holding charge of nitrogen.
- Compressor time delay control – compressor will remain off for five minutes after power or thermostat interruption, allowing system pressures to equalize. (Model No. RXMD-B01)
- Filter/Drier – a liquid line filter drier is shipped with each unit for field installation.

## Introduction to RAWL- Air Conditioner

Our unique composite base (1) reduces sound emission, eliminates rattles, significantly reduces fasteners, eliminates corrosion and has integrated brass compressor attachment inserts (2). Furthermore it has incorporated into the design, water management features, means for hand placement (3) for unit maneuvering, screw trays (4) and inserts for lifting off unit pad. (5)

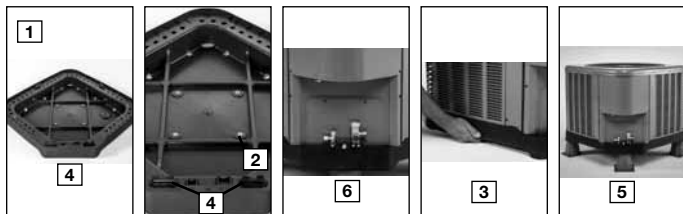

Service Valves (6) are rigidly mounted in the composite base with 3" between suction and discharge valves, 4" clearance below service valves and a minimum of 5" above the service valves, creating industry leading installation ease. The minimum 27 square-inches around the service valves allows ample room to remove service valve schrader prior to brazing, plenty of clearance for easy brazing of the suction and discharge lines to service valve outlets, easy access and hookup of low loss refrigerant gauges (7), and access to the service valve caps for opening. For applications with long-line lengths up to 250 feet total equivalent length, up to 200 feet condenser above evaporator, or up to 80 feet evaporator above condenser, the long-line instructions in the installation manual should be followed.

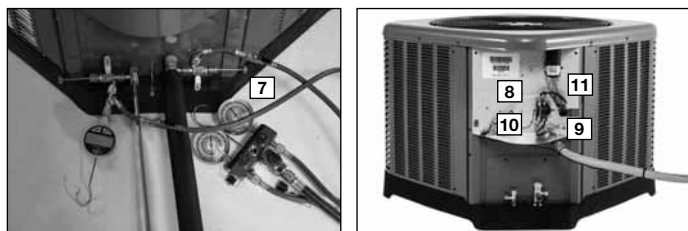

Controls are accessed from the corner of the unit by removing only two fasteners from the control access cover, revealing the industry's largest 15" wide and 14" tall control area (8). With all this room in the control area the high voltage electrical whip (9) can easily be inserted through the right size opening in the bottom of the control area. Routing it leads directly to contractor lugs for connection. The low voltage control wires (10) are easily connected to units low voltage wiring. If contactor or capacitor (11) needs to be replaced there is more than adequate space to make the repair. Furthermore, if high pressure and low pressure model was not purchased but is desired to be installed in the field, the service window (12) can be removed by removing two screws, to access the high and low side schrader fittings for easy field installation. The entire corner can be removed providing ultimate access to install the high and low pressure switch. (13)

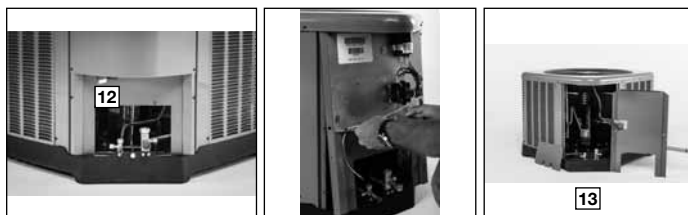

If in the rare event, greater access is needed to internal components, such as the compressor, the entire corner of the unit can be removed along with the top cover assembly to have unprecedented access to interior of the unit (14). Extra wire length is incorporated into each outdoor fan and compressor so top cover and control panel can be positioned next to the unit. With minimal effort the plug can be removed from the compressor and the outdoor fan wires can be removed from the capacitor to allow even more uncluttered access to the interior of the unit (15). Outdoor coil heights range from as short as 27" to 48", aiding access to the compressor. Disassembly to this degree and complete reassembly only takes a first time service technician less than 10 minutes. (15)

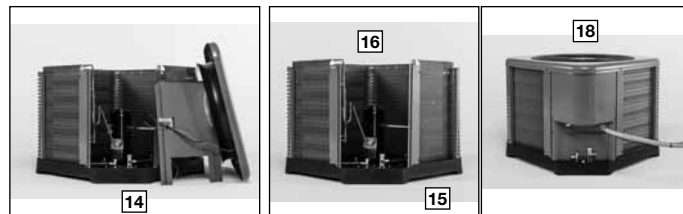

All units utilize strong formed louver panels which provide industry leading coil protection. Louver removal for coil cleaning is accomplished by removing one screw and lifting the panel out of the composite base pan. (17) All RAWL units utilize single row coils (16) making cleaning easy and complete, restoring the performance of the air conditioner back to out of the box performance levels year after year.

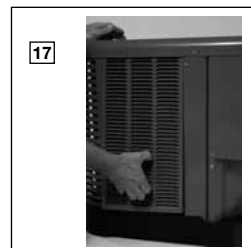

The outdoor fan motor has sleeve bearings and is inherently protected. The motor is totally enclosed for maximum protection from weather, dust and corrosion. Access to the outdoor fan is made by removing four fasteners from the fan grille. The outdoor fan can be removed from the fan grille by removing 4 fasteners in the rare case outdoor fan motor fails.

Each cabinet has optimized composite (19) fan orifice assuring efficient and quiet airflow.



The entire cabinet has powder post paint (20) achieving 1000 hour salt spray rating, allowing the cabinet to retain its aesthetics throughout its life.

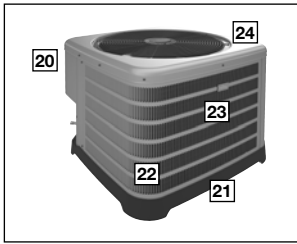

Scroll compressors with standard internal pressure relief and internal thermal overload are used on all capacities assuring longevity of high efficient and quiet operation for the life of the product.

Each unit is shipped with filter drier for field installation and will trap any moisture or dirt that could contaminate the refrigerant system.



All cabinets have industry leading structural strength due to the composite base pan (21), interlocking corner post (22), formed curved louver panels (23) and drawn top cover (24) making it the most durable cabinet on the market today.

Each RAWL capacity has undergone rigorous psychrometric testing to assure performance ratings of capacity, IEER per AHRI Standard 210/240 rating conditions. Also each unit bears the UL mark and each unit is certified to UL 1995 safety standards.



Each unit has undergone specific strain and modal testing to assure tubing (25) is outside the units natural frequency and that the suction and discharge lines connected to the compressor withstand any starting, steady state operation or shut down forces imposed by the compressor.

All units have been sound tested in sound chamber to AHRI 270 rating conditions, and A-weighted Sound Power Level tables produced, assuring units have acceptable noise qualities (see page 8). Each unit has been ran in cooling operation at 95°F and 82°F and sound ratings for the RAWL range from as low as 70.7 dBA to 76.6 dBA.

All units have been ship tested to assure units meet stringent “over the road” shipping conditions.

Factory testing is performed on each unit. All component parts meet well defined specification and continually go through receiving inspections. Each component installed on a unit is scanned, assuring correct component utilization for a given unit capacity and voltage. All condenser coils are leak tested with pressurization test to 550#’s and once installed and assembled, each units’ complete refrigerant system is helium leak tested. All units are factory run tested.

### Optional Accessories (Refer to accessory chart for model #)

#### Compressor Crankcase Heater

Protects against refrigerant migration that can occur during low ambient operation

#### Compressor Sound Cover

- Reinforced vinyl compressor cover containing a 1½ inch thick batt of fiberglass insulation
- Open edges are sealed with a one-inch wide hook and loop fastening tape

#### 3”/6”/12”

- Gray high density polyethylene feet are available to raise unit off of mounting surface away from moisture

#### Decorative Top

- Can be installed on fan grille

## MODEL IDENTIFICATION

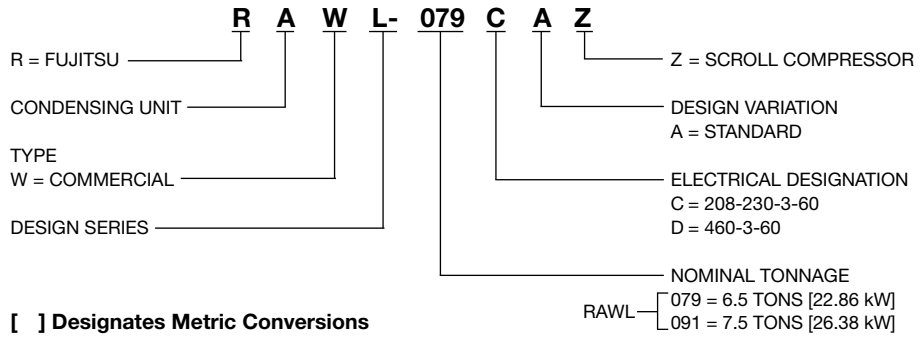

<b>Physical Data (RAWL-)</b>		
<b>Model No.</b>	<b>079</b>	<b>091</b>
<b>Condensing Unit:</b>		
Operating Weight (lbs) [kg]	245 [111.1]	307 [139.2]
Shipping Weight (lbs) [kg]	252 [114.3]	313 [141.9]
<b>Compressor:</b>		
Quantity	1	1
Type	Scroll	Scroll
RPM	3500	3500
<b>Condenser Fans:</b>		
Quantity	1	1
CFM [L/s]	5700 [2690]	5700 [2690]
Diameter (in.) [mm]	26 [660]	26 [660]
Motor Horsepower (ea.) [W]	1/2 [373]	1/2 [373]
Type	ECM	ECM
RPM	975	975
<b>Condenser Coil:</b>		
Quantity	1	1
Rows	1	2
Fins per Inch	22	22
Square Feet [m2]	28.38 [2.64]	32.44 [3.01]
Fins/Tubes	Aluminum / Copper 3/8 [10]	Aluminum / Copper 3/8 [10]

<b>Electrical Data (RAWL-)</b>				
<b>Model No.</b>	<b>079CAZ</b>	<b>079DAZ</b>	<b>091CAZ</b>	<b>091DAZ</b>
<b>Compressor Motor:</b>				
Electrical Characteristics	208/230-3-60	460-3-60	208/230-3-60	460-3-60
<b>Operating Current:</b>				
Rated Load Amps	25	11.8	27.9	13.6
Locked Rotor Amps	149	83	164	100
<b>Condenser Fan Motors:</b>				
Volts & Phase	208/230-1	460-1	208/230-1	460-1
Full Load Amps (each)	5.3	2.2	5.3	2.2
<b>System Characteristics:</b>				
Unit FLA	27.7	15.9	30.3	17.5
Minimum Circuit Ampacity	34	19	37	21
Max. Fuse Size or HACR Circuit Breaker Ampacity	50/40	25/25	60/45	30/25
Disconnect Size	60	30	65	35

NOTE: N.E.C., C.E.C. and local codes take precedence over suggested wire and fuse size.

[ ] Designates Metric Conversions

## CONDENSING UNIT ACCESSORIES

ACCESSORY DESCRIPTION	MODEL NUMBER	SIZES USED ON
Anti-Short Cycle Timer Kit	RXAT-A01	RAWL-079, 091
Sight Glass	RXAG-A048	RAWL-079, 091
Liquid Line Solenoid Valve*	RXAV-CD078	RAWL-079, 091

\*May be used as isolation valve only. Do not use as a pump-down solenoid. Refer to system wiring diagram.

## SELECTION PROCEDURE— MATCHED SYSTEMS

**Example 1:** Determine the Net System Performance of Condensing Unit RAWL-091 with RHGL-090 at 3360 CFM [1586 L/s] @ .30" [.07 kPa] external static pressure, 80°F [27°C] DB/67°F [19°C] WB entering indoor air and 95°F [35°C] DB outdoor ambient.

From Performance Data—Condensing Unit RAWL-091 with Air Handler RHGL-090Z:

$$\text{Total Cap. (gross)} = 92.4 \times 1000 = 92,400 \text{ BTUH [27.07 kW]}$$

$$\text{Sens. Cap. (gross)} = 67.2 \times 1000 = 67,200 \text{ BTUH [19.69 kW]}$$

$$\text{Power (gross)} = 7.1 \times 1000 = 7,100 \text{ WATTS}$$

From Commercial Air Handler, Wet Coil Airflow Performance Data:

$$\text{Power} = 1,056 \text{ WATTS}$$

$$= 1,056 \times 3.412 = 3,603 \text{ BTUH [1.06 kW]}$$

Therefore, the Net Performance is:

$$\text{Total Cap. (Net)} = 92,400 - 3,603 = 88,797 \text{ BTUH [26.02 kW]}$$

$$\text{Sens. Cap (Net)} = 67,200 - 3,603 = 63,597 \text{ BTUH [18.63 kW]}$$

$$\text{Power (Net)} = 7,100 + 1,056 = 8,156 \text{ WATTS}$$

$$\text{EER} = 88,797 \div 8,156 = 10.89 \text{ BTUH [3.16 w/w] WATT}$$

**Example 2:** Determine the Sensible Net Capacity at 75°F [27°C] DB entering indoor air with the other conditions from Example 1 being the same.

From Performance Data—Condensing Unit RAWL-091 with Air Handler RHGL-090

$$\text{Sens. Cap (Net)} = 63,597 \text{ BTUH [18.63 kW]}$$

(from Example 1)

Adjust Capacity for temperature other than 80°F [27°C] entering air:

$$\text{Adjustment: } [1.1 \times 2,725 \times (1-.09) \times (75-80)] = -13,638 \text{ BTUH [3.99 kW]}$$

Therefore, Sensible Capacity (Net) at 75°F [24°C] entering air is:

$$63,597 - 13,638 = 49,959 \text{ BTUH [14.64 kW] (Sens.)}$$

**Example 3:** Determine Net System Capacity Performance with 150 feet [45.7 m] equivalent length of 1<sup>3</sup>/<sub>8</sub>" [34.9 mm] O.D. vapor line, with other conditions in example 1 being the same.

From piping chart, Vapor Line System Capacity Loss, in this booklet:

$$\text{Capacity Loss} = 1.3\% \text{ per } 100 [30.5\text{m}] \text{ feet of line}$$

The condensing unit Performance Data includes 25 feet [7.6 m] of recommended vapor line; therefore, calculate the System performance with 125 feet [38.1 m] of additional line:

$$\text{Total Cap. (gross)} = 92,400 - [(0.013 \times 125 \div 100) \times 92,400] = 90,898 \text{ BTUH [26.63 kW]}$$

$$\text{Sens. Cap (gross)} = 67,200 - [(0.013 \times 125 \div 100) \times 67,200] = 66,108 \text{ BTUH [19.37 kW]}$$

Thus, the Net Performance is:

$$\text{Total Cap. (Net)} = 90,898 - 3,603 = 87,295 \text{ BTUH [25.58 kW]}$$

$$\text{Sens. Cap. (Net)} = 66,108 - 3,603 = 62,505 \text{ BTUH [18.31 kW]}$$

[ ] Designates Metric Conversions



## CONDENSING UNIT—GROSS CAPACITY AND POWER

<b>RAWL-079</b>						
°F [°C] OUTDOOR AMBIENT TEMPERATURE	SATURATED EVAPORATOR TEMPERATURE					
	40 [4]		45 [7]		50 [10]	
	MBH [kW]	KW	MBH [kW]	KW	MBH [kW]	KW
75 [24]	86.1 [25.2]	4.9	93.9 [27.5]	5.0	104.6 [30.7]	4.3
80 [27]	83.6 [24.5]	5.1	91.2 [26.7]	5.2	102.5 [30.0]	4.5
85 [29]	81.2 [23.8]	5.4	88.6 [26.0]	5.4	96.4 [28.3]	5.5
90 [32]	78.7 [23.1]	5.6	85.9 [25.2]	5.7	93.6 [27.4]	5.8
95 [35]	76.2 [22.3]	5.9	83.2 [24.4]	6.0	90.7 [26.6]	6.0
100 [38]	73.6 [21.6]	6.2	80.5 [23.6]	6.2	87.7 [25.7]	6.3
105 [41]	70.7 [20.7]	6.5	77.7 [22.8]	6.5	84.4 [24.7]	6.6
110 [43]	68.0 [19.9]	6.8	74.5 [21.8]	6.9	81.4 [23.8]	7.0
115 [46]	61.4 [18.0]	9.6	69.5 [20.4]	9.5	76.8 [22.5]	9.3

<b>RAWL-091</b>						
°F [°C] OUTDOOR AMBIENT TEMPERATURE	SATURATED EVAPORATOR TEMPERATURE					
	40 [4]		45 [7]		50 [10]	
	MBH [kW]	KW	MBH [kW]	KW	MBH [kW]	KW
75 [24]	103.4 [30.3]	6.0	112.1 [32.8]	6.1	121.3 [35.6]	6.3
80 [27]	100.7 [29.5]	6.3	109.2 [32.0]	6.4	118.3 [34.7]	6.6
85 [29]	97.9 [28.7]	6.6	106.2 [31.1]	6.7	115.1 [33.7]	6.9
90 [32]	95.0 [27.9]	6.9	103.2 [30.3]	7.0	111.9 [32.8]	7.2
95 [35]	92.1 [27.0]	7.2	100.2 [29.4]	7.3	108.5 [31.8]	7.6
100 [38]	89.2 [26.1]	7.6	96.9 [28.4]	7.7	104.9 [30.7]	7.9
105 [41]	86.0 [25.2]	7.9	93.2 [27.3]	8.1	101.3 [29.7]	8.3
110 [43]	82.8 [24.3]	8.3	89.8 [26.3]	8.5	97.6 [28.6]	8.7
115 [46]	79.9 [23.4]	8.6	88.4 [25.9]	8.8	95.5 [28.0]	9.0

KW — Condensing Unit Power (Compressor + Fan)

MBH— Gross Capacity X 1000 BTUH

NOTES: 1. All values at approximately 20°F [11.1°C] subcooling

2. Data includes 25 feet [7.62 m] of recommended vapor and liquid lines

[ ] Designates Metric Conversions

## Unit Dimensions

(-)AWL	-079	-091
Height "H" Inches [mm]	45 [1143]	51 [1295]
Length "L" Inches [mm]	35.75 [908]	35.75 [908]
Width "W" Inches [mm]	35.75 [908]	35.75 [908]

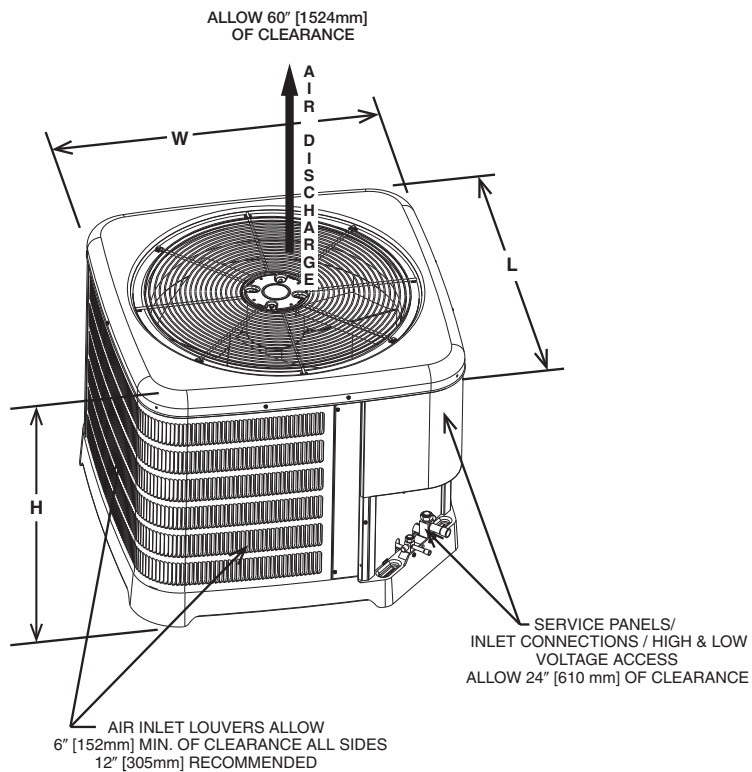

ST-A1226-23-00

[ ] Designates Metric Conversions

### 6.5 Ton [22.86 kW], 7.5 Ton [26.38 kW] Corner Weights (Lbs.) [kg]

UNIT MODEL	TOTAL WEIGHT LBS [kg]	CORNER WEIGHTS, LBS. [kg]			
		A	B	C	D
RAWL-079	245	71	54	84	36
RAWL-091	313	91	69	107	46

# CLEARANCES

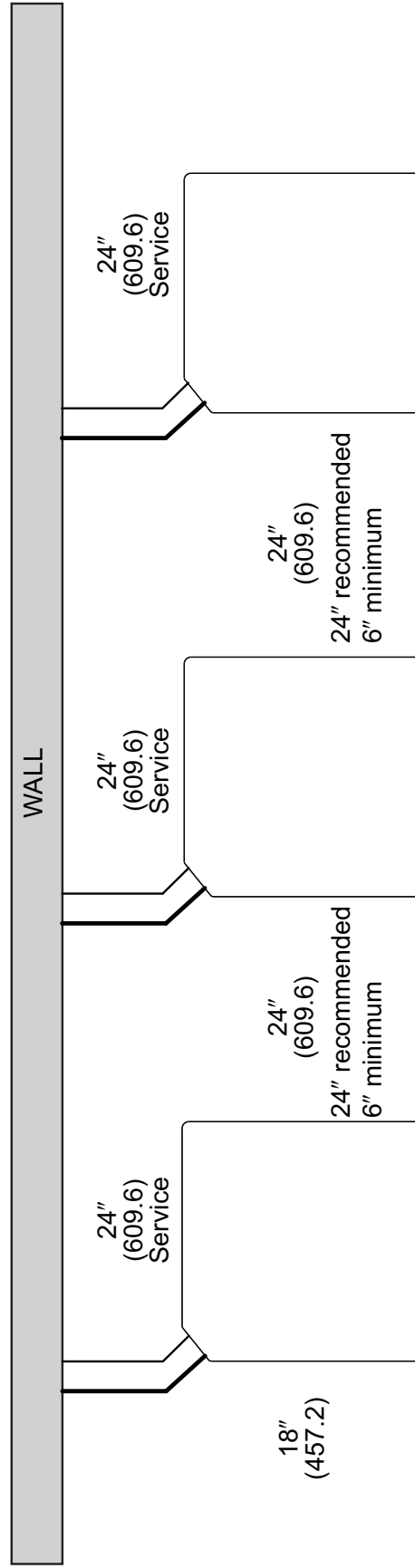
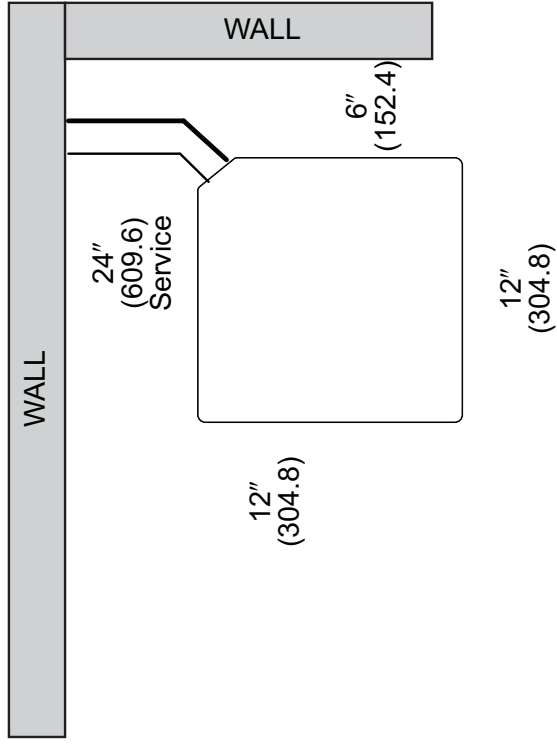
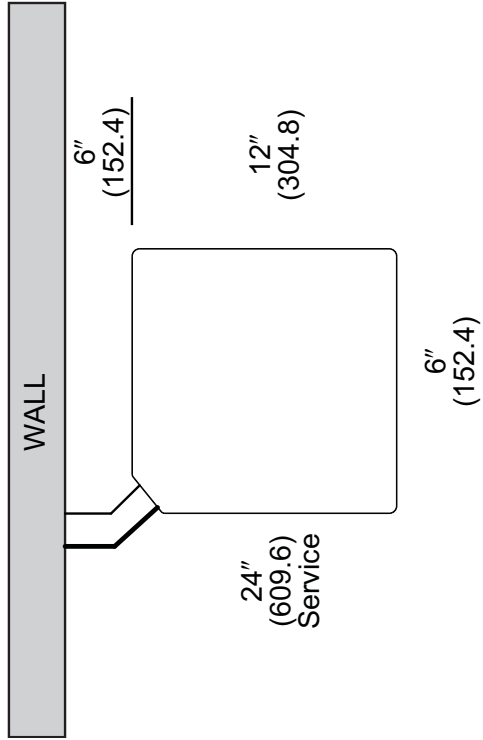

**NOTE: NUMBERS IN ( ) = mm**

**IMPORTANT:** When installing multiple units in an alcove, roof well or partially enclosed area, ensure there is adequate ventilation to prevent re-circulation of discharge air.

## Performance Data @ AHRI Standard Conditions

Model Numbers		80°F [26.5°C] DB 67°F [19.5°C] WB Indoor Air 95°F [35°C] DB Outdoor Air					Sound Rating	Rated Indoor CFM [L/s]
Outdoor Unit RAWL-	Indoor Coil And/Or Air Handler	Total Capacity BTU/H [kW]	Net Sensible BTU/H [kW]	Net Latent BTU/H [kW]	EER	IEER		
079CAZ	RHGL-090Z ①	77,000 [22.5]	56,700 [16.6]	20,300 [5.95]	11.50	12.90	8.6	2575 [1215]
079DAZ	RHGL-090Z	77,000 [22.5]	56,700 [16.6]	20,300 [5.95]	11.50	12.90	8.6	2575 [1215]
091CAZ	RHGL-090Z ①	90,000 [26.4]	64,400 [18.9]	25,600 [7.50]	11.50	12.90	8.6	2725 [1286]
	RHGL-120Z	92,000 [26.9]	65,500 [19.2]	26,500 [7.70]	11.60	13.00	8.6	2800 [1321]
091DAZ	RHGL-090Z	90,000 [26.4]	64,400 [18.9]	25,600 [7.50]	11.50	12.90	8.6	2725 [1286]
	RHGL-120Z	92,000 [26.9]	65,500 [19.2]	26,500 [7.70]	11.60	13.00	8.6	2800 [1321]

① Highest sales volume tested combination required by D.O.E. test procedures.

[ ] Designates Metric Conversions

# COOLING PERFORMANCE DATA—RAWL -079 + RHGL -090Z

wBe		ENTERING INDOOR AIR @ 80°F [26.7°C] dbE ①														
		71°F [21.7°C]			67°F [19.4°C]			63°F [17.2°C]			61°F [16.1°C]			59°F [15.0°C]		
CFM [L/s]		3120 [1472]	2575 [1215]	2080 [982]	3120 [1472]	2575 [1215]	2080 [982]	3120 [1472]	2575 [1215]	2080 [982]	3120 [1472]	2575 [1215]	2080 [982]	3120 [1472]	2575 [1215]	2080 [982]
DR ①		0.14	0.1	0.06	0.14	0.1	0.06	0.14	0.1	0.06	0.14	0.1	0.06	0.14	0.1	0.06
75 [23.9]	Total BTUH [kW]	95.5 [28.0]	92.0 [26.9]	88.7 [26.0]	90.5 [26.5]	87.1 [25.5]	84.1 [24.6]	84.0 [24.6]	80.8 [23.7]	78.0 [22.9]	80.1 [23.5]	77.2 [22.6]	74.5 [21.8]	75.9 [22.2]	73.1 [21.4]	70.6 [20.7]
	Sens BTUH [kW]	59.1 [17.3]	53.8 [15.8]	48.9 [14.3]	69.8 [20.4]	63.5 [18.6]	57.8 [16.9]	78.2 [22.9]	71.2 [20.9]	64.8 [19.0]	80.1 [23.5]	74.2 [21.7]	67.5 [19.8]	75.9 [22.2]	73.1 [21.4]	69.8 [20.5]
	Power	5.3	5.2	5.1	5.2	5.2	5.1	5.2	5.1	5.0	5.2	5.1	5.0	5.1	5.0	4.9
80 [26.7]	Total BTUH [kW]	93.7 [27.5]	90.2 [26.4]	87.1 [25.5]	88.7 [26.0]	85.4 [25.0]	82.4 [24.1]	82.1 [24.1]	79.1 [23.2]	76.3 [22.4]	78.3 [22.9]	75.4 [22.1]	72.8 [21.3]	74.1 [21.7]	71.4 [20.9]	68.9 [20.2]
	Sens BTUH [kW]	58.1 [17.0]	52.9 [15.5]	48.2 [14.1]	68.8 [20.2]	62.6 [18.4]	57.0 [16.7]	77.2 [22.6]	70.3 [20.6]	64.0 [18.8]	78.3 [22.9]	73.3 [21.5]	66.8 [19.6]	74.1 [21.7]	71.4 [20.9]	68.9 [20.2]
	Power	5.6	5.5	5.4	5.5	5.4	5.3	5.4	5.3	5.2	5.4	5.3	5.2	5.4	5.3	5.2
85 [29.4]	Total BTUH [kW]	91.8 [26.9]	88.4 [25.9]	85.3 [25.0]	86.8 [25.4]	83.6 [24.5]	80.7 [23.6]	80.3 [23.5]	77.3 [22.7]	74.6 [21.9]	76.4 [22.4]	73.6 [21.6]	71.0 [20.8]	72.2 [21.2]	69.6 [20.4]	67.1 [19.7]
	Sens BTUH [kW]	57.2 [16.8]	52.1 [15.3]	47.4 [13.9]	67.9 [19.9]	61.8 [18.1]	56.3 [16.5]	76.3 [22.4]	69.5 [20.4]	63.2 [18.5]	76.4 [22.4]	72.5 [21.2]	66.0 [19.3]	72.2 [21.2]	69.6 [20.4]	67.1 [19.7]
	Power	5.8	5.7	5.6	5.8	5.7	5.6	5.7	5.6	5.5	5.7	5.6	5.5	5.6	5.5	5.4
90 [32.2]	Total BTUH [kW]	89.9 [26.3]	86.6 [25.4]	83.5 [24.5]	84.9 [24.9]	81.7 [24.0]	78.9 [23.1]	78.4 [23.0]	75.5 [22.1]	72.8 [21.3]	74.5 [21.8]	71.8 [21.0]	69.3 [20.3]	70.3 [20.6]	67.7 [19.8]	65.4 [19.2]
	Sens BTUH [kW]	56.3 [16.5]	51.2 [15.0]	46.7 [13.7]	67.0 [19.6]	61.0 [17.9]	55.5 [16.3]	75.4 [22.1]	68.6 [20.1]	62.5 [18.3]	74.5 [21.8]	71.7 [21.0]	65.2 [19.1]	70.3 [20.6]	67.7 [19.8]	65.4 [19.2]
	Power	6.1	6.0	5.9	6.1	5.9	5.8	6.0	5.9	5.8	6.0	5.8	5.7	5.9	5.8	5.7
95 [35]	Total BTUH [kW]	87.9 [25.8]	84.7 [24.8]	81.7 [23.9]	82.9 [24.3]	79.9 [23.4]	77.1 [22.6]	76.4 [22.4]	73.6 [21.6]	71.0 [20.8]	72.6 [21.3]	69.9 [20.5]	67.4 [19.8]	68.4 [20.0]	65.8 [19.3]	63.5 [18.6]
	Sens BTUH [kW]	55.4 [16.2]	50.4 [14.8]	45.9 [13.5]	66.1 [19.4]	60.2 [17.6]	54.8 [16.0]	74.5 [21.8]	67.8 [19.9]	61.7 [18.1]	72.6 [21.3]	69.9 [20.5]	64.5 [18.9]	68.4 [20.0]	65.8 [19.3]	63.5 [18.6]
	Power	6.4	6.3	6.2	6.4	6.2	6.1	6.3	6.2	6.1	6.3	6.1	6.0	6.2	6.1	6.0
100 [37.8]	Total BTUH [kW]	85.9 [25.2]	82.8 [24.2]	79.9 [23.4]	80.9 [23.7]	77.9 [22.8]	75.2 [22.0]	74.4 [21.8]	71.6 [21.0]	69.1 [20.3]	70.6 [20.7]	68.0 [19.9]	65.6 [19.2]	66.4 [19.4]	63.9 [18.7]	61.7 [18.1]
	Sens BTUH [kW]	54.5 [16.0]	49.6 [14.5]	45.2 [13.2]	65.2 [19.1]	59.4 [17.4]	54.0 [15.8]	73.6 [21.6]	67.0 [19.6]	61.0 [17.9]	70.6 [20.7]	68.0 [19.9]	63.8 [18.7]	66.4 [19.4]	63.9 [18.7]	61.7 [18.1]
	Power	6.7	6.6	6.5	6.7	6.5	6.4	6.6	6.5	6.4	6.6	6.5	6.3	6.5	6.4	6.3
105 [40.6]	Total BTUH [kW]	83.9 [24.6]	80.8 [23.7]	78.0 [22.8]	78.9 [23.1]	76.0 [22.3]	73.3 [21.5]	72.4 [21.2]	69.7 [20.4]	67.2 [19.7]	68.5 [20.1]	66.0 [19.3]	63.7 [18.7]	64.3 [18.8]	61.9 [18.1]	59.8 [17.5]
	Sens BTUH [kW]	53.7 [15.7]	48.8 [14.3]	44.4 [13.0]	64.3 [18.9]	58.6 [17.2]	53.3 [15.6]	72.4 [21.2]	66.2 [19.4]	60.3 [17.7]	68.5 [20.1]	66.0 [19.3]	63.0 [18.5]	64.3 [18.8]	61.9 [18.1]	59.8 [17.5]
	Power	7.1	6.9	6.8	7.0	6.9	6.8	6.9	6.8	6.7	6.9	6.8	6.7	6.9	6.7	6.6
110 [43.3]	Total BTUH [kW]	81.8 [24.0]	78.8 [23.1]	76.0 [22.3]	76.8 [22.5]	73.9 [21.7]	71.3 [20.9]	70.3 [20.6]	67.6 [19.8]	65.3 [19.1]	66.4 [19.5]	64.0 [18.7]	61.7 [18.1]	62.2 [18.2]	59.9 [17.6]	57.8 [16.9]
	Sens BTUH [kW]	52.8 [15.5]	48.0 [14.1]	43.7 [12.8]	63.5 [18.6]	57.8 [16.9]	52.6 [15.4]	70.3 [20.6]	65.4 [19.2]	59.6 [17.5]	66.4 [19.5]	64.0 [18.7]	61.7 [18.1]	62.2 [18.2]	59.9 [17.6]	57.8 [16.9]
	Power	7.4	7.3	7.2	7.4	7.2	7.1	7.3	7.2	7.0	7.3	7.1	7.0	7.2	7.1	7.0
115 [46.1]	Total BTUH [kW]	79.6 [23.3]	76.7 [22.5]	74.0 [21.7]	74.6 [21.9]	71.9 [21.1]	69.4 [20.3]	68.1 [20.0]	65.6 [19.2]	63.3 [18.5]	64.3 [18.8]	61.9 [18.1]	59.7 [17.5]	60.1 [17.6]	57.8 [16.9]	55.8 [16.4]
	Sens BTUH [kW]	51.9 [15.2]	47.3 [13.9]	43.0 [12.6]	62.6 [18.4]	57.0 [16.7]	51.9 [15.2]	68.1 [20.0]	64.7 [18.9]	58.9 [17.2]	64.3 [18.8]	61.9 [18.1]	59.7 [17.5]	60.1 [17.6]	57.8 [16.9]	55.8 [16.4]
	Power	7.8	7.6	7.5	7.7	7.6	7.4	7.7	7.6	7.5	7.4	7.5	7.4	7.6	7.5	7.3
120 [48.9]	Total BTUH [kW]	77.4 [22.7]	74.6 [21.9]	72.0 [21.1]	72.4 [21.2]	69.8 [20.4]	67.3 [19.7]	65.9 [19.3]	63.5 [18.6]	61.2 [17.9]	62.1 [18.2]	59.8 [17.5]	57.7 [16.9]	57.9 [17.0]	55.7 [16.3]	53.8 [15.8]
	Sens BTUH [kW]	51.1 [15.0]	46.5 [13.6]	42.3 [12.4]	61.8 [18.1]	56.2 [16.5]	51.2 [15.0]	65.9 [19.3]	63.5 [18.6]	58.2 [17.0]	62.1 [18.2]	59.8 [17.5]	57.7 [16.9]	57.9 [17.0]	55.7 [16.3]	53.8 [15.8]
	Power	8.2	8.0	7.9	8.1	8.0	7.8	8.0	7.9	7.8	8.0	7.9	7.7	8.0	7.8	7.7
125 [51.7]	Total BTUH [kW]	75.2 [22.0]	72.4 [21.2]	69.9 [20.5]	70.2 [20.6]	67.6 [19.8]	65.2 [19.1]	63.7 [18.7]	61.3 [18.0]	59.2 [17.3]	59.8 [17.5]	57.6 [16.9]	55.6 [16.3]	55.6 [16.3]	53.6 [15.7]	51.7 [15.1]
	Sens BTUH [kW]	50.3 [14.7]	45.8 [13.4]	41.7 [12.2]	61.0 [17.9]	55.5 [16.3]	50.5 [14.8]	63.7 [18.7]	61.3 [18.0]	57.5 [16.8]	59.8 [17.5]	57.6 [16.9]	55.6 [16.3]	55.6 [16.3]	53.6 [15.7]	51.7 [15.1]
	Power	8.6	8.4	8.3	8.5	8.3	8.2	8.4	8.3	8.1	8.4	8.2	8.1	8.4	8.2	8.1

DR —Depression ratio  
dbE —Entering air dry bulb  
wBe —Entering air wet bulb

Total —Total capacity x 1000 BTUH  
Sens —Sensible capacity x 1000 BTUH  
Power —KW input

NOTES: ① When the entering air dry bulb is other than 80°F [27°C], adjust the sensible capacity from the table by adding [(1 - DR) x (dbE - 80)].

[ ] Designates Metric Conversions

# COOLING PERFORMANCE DATA—RAWL -091 + RHGL -090Z

		ENTERING INDOOR AIR @ 80°F [26.7°C] dBE ①											
		71°F [21.7°C]		67°F [19.4°C]		63°F [17.2°C]		61°F [16.1°C]		59°F [15.0°C]			
wBE		3360 [1586]	2725 [1286]	2240 [1057]	3360 [1586]	2725 [1286]	2240 [1057]	3360 [1586]	2725 [1286]	2240 [1057]	3360 [1586]	2725 [1286]	2240 [1057]
CFM [L/s]		0.13	0.09	0.06	0.13	0.09	0.06	0.13	0.09	0.06	0.13	0.09	0.06
DR ①													
75 [23.9]	Total BTUH [kW]	107.9 [31.6]	103.5 [30.3]	100.2 [29.4]	102.9 [30.1]	98.7 [28.9]	95.5 [28.0]	96.3 [28.2]	92.4 [27.1]	89.4 [26.2]	85.8 [25.1]	88.2 [25.9]	81.9 [24.0]
	Sens BTUH [kW]	65.4 [19.2]	59.0 [17.3]	54.1 [15.9]	77.6 [22.8]	70.0 [20.5]	64.2 [18.8]	87.7 [25.7]	79.1 [23.2]	72.5 [21.3]	76.0 [22.3]	88.2 [25.9]	84.6 [24.8]
80 [26.7]	Power	6.0	5.9	5.8	5.9	5.8	5.7	5.8	5.7	5.6	5.5	5.7	5.5
	Total BTUH [kW]	106.7 [31.3]	102.4 [30.0]	99.0 [29.0]	101.6 [29.8]	97.5 [28.6]	94.3 [27.6]	95.1 [27.9]	91.2 [26.7]	88.2 [25.9]	84.7 [24.8]	87.0 [25.5]	80.8 [23.7]
85 [29.4]	Sens BTUH [kW]	64.8 [19.0]	58.5 [17.1]	53.6 [15.7]	77.1 [22.6]	69.5 [20.4]	63.7 [18.7]	87.1 [25.5]	78.6 [23.0]	72.1 [21.1]	75.6 [22.1]	83.5 [24.5]	
	Power	6.3	6.2	6.1	6.2	6.1	6.0	6.1	6.0	5.9	5.8	6.0	5.9
90 [32.2]	Total BTUH [kW]	105.2 [30.8]	100.9 [29.6]	97.6 [28.6]	100.1 [29.3]	96.0 [28.1]	92.9 [27.2]	93.5 [27.4]	89.7 [26.3]	86.8 [25.4]	83.3 [24.4]	85.5 [25.1]	
	Sens BTUH [kW]	64.1 [18.8]	57.8 [16.9]	53.0 [15.5]	76.3 [22.4]	68.9 [20.2]	63.1 [18.5]	86.4 [25.3]	77.9 [22.8]	71.5 [20.9]	75.0 [22.0]	85.5 [25.1]	
95 [35]	Power	6.6	6.5	6.4	6.5	6.4	6.3	6.4	6.3	6.2	6.1	6.3	6.2
	Total BTUH [kW]	103.4 [30.3]	99.2 [29.1]	96.0 [28.1]	98.3 [28.8]	94.3 [27.6]	91.3 [26.7]	91.8 [26.9]	87.9 [25.8]	85.2 [25.0]	81.6 [23.9]	83.7 [24.5]	
100 [37.8]	Sens BTUH [kW]	63.2 [18.5]	57.0 [16.7]	52.3 [15.3]	75.5 [22.1]	68.1 [19.9]	62.4 [18.3]	85.5 [25.1]	77.2 [22.6]	70.7 [20.7]	74.2 [21.8]	80.3 [23.5]	
	Power	7.0	6.9	6.8	6.9	6.8	6.7	6.8	6.7	6.6	6.5	6.7	6.5
105 [40.6]	Total BTUH [kW]	101.3 [29.7]	97.2 [28.5]	94.1 [27.6]	96.3 [28.2]	92.4 [27.1]	89.4 [26.2]	89.7 [26.3]	86.1 [25.2]	83.3 [24.4]	79.7 [23.4]	81.6 [23.9]	
	Sens BTUH [kW]	62.2 [18.2]	56.1 [16.4]	51.5 [15.1]	74.5 [21.8]	67.2 [19.7]	61.6 [18.0]	84.5 [24.8]	76.2 [22.3]	69.9 [20.5]	73.4 [21.5]	81.6 [23.9]	
110 [43.3]	Power	7.4	7.2	7.1	7.3	7.1	7.0	7.2	7.0	6.9	6.9	7.1	6.9
	Total BTUH [kW]	99.0 [29.0]	95.0 [27.8]	91.9 [26.9]	93.9 [27.5]	90.1 [26.4]	87.2 [25.6]	87.4 [25.6]	83.8 [24.6]	81.1 [23.8]	77.5 [22.7]	79.3 [23.2]	
115 [46.1]	Sens BTUH [kW]	61.1 [17.9]	55.1 [16.1]	50.5 [14.8]	73.3 [21.5]	66.1 [19.4]	60.6 [17.8]	83.4 [24.4]	75.2 [22.0]	68.9 [20.2]	72.4 [21.2]	76.1 [22.3]	
	Power	7.8	7.6	7.5	7.7	7.5	7.4	7.6	7.4	7.3	7.3	7.5	7.3
120 [48.9]	Total BTUH [kW]	96.4 [28.2]	92.5 [27.1]	89.5 [26.2]	91.3 [26.8]	87.6 [25.7]	84.8 [24.8]	84.8 [24.8]	81.3 [23.8]	78.7 [23.1]	75.1 [22.0]	76.7 [22.5]	
	Sens BTUH [kW]	59.7 [17.5]	53.9 [15.8]	49.4 [14.5]	70.5 [20.7]	63.6 [18.6]	59.5 [17.4]	82.0 [24.0]	74.0 [21.7]	67.9 [19.9]	71.4 [20.9]	76.7 [22.5]	
125 [51.7]	Power	8.2	8.1	7.9	8.1	7.9	7.8	8.0	7.8	7.7	7.7	7.9	7.7
	Total BTUH [kW]	93.5 [27.4]	89.7 [26.3]	86.8 [25.4]	88.4 [25.9]	84.8 [24.9]	82.1 [24.1]	81.9 [24.0]	78.0 [22.9]	76.0 [22.3]	72.4 [21.2]	73.8 [21.6]	
130 [54.3]	Sens BTUH [kW]	58.3 [17.1]	52.6 [15.4]	48.2 [14.1]	70.5 [20.7]	63.6 [18.6]	58.3 [17.1]	80.6 [23.6]	72.7 [21.3]	66.6 [19.5]	70.1 [20.6]	73.8 [21.6]	
	Power	8.7	8.5	8.4	8.6	8.4	8.2	8.4	8.3	8.1	8.1	8.3	8.2
135 [56.9]	Total BTUH [kW]	90.3 [26.5]	86.7 [25.4]	83.9 [24.6]	85.3 [25.0]	81.8 [24.0]	79.2 [23.2]	78.7 [23.1]	75.5 [22.1]	73.1 [21.4]	69.5 [20.4]	70.6 [20.7]	
	Sens BTUH [kW]	56.7 [16.6]	51.1 [15.0]	46.9 [13.7]	68.9 [20.2]	62.1 [18.2]	57.0 [16.7]	78.7 [23.1]	71.2 [20.9]	65.3 [19.1]	68.8 [20.2]	70.6 [20.7]	
140 [59.5]	Power	9.1	8.9	8.8	9.0	8.8	8.7	8.9	8.7	8.6	8.5	8.8	8.6
	Total BTUH [kW]	86.9 [25.5]	83.4 [24.4]	80.7 [23.6]	81.8 [24.0]	78.5 [23.0]	76.0 [22.3]	75.3 [22.1]	72.2 [21.2]	69.9 [20.5]	66.3 [19.4]	67.2 [19.7]	
145 [62.1]	Sens BTUH [kW]	54.9 [16.1]	49.5 [14.5]	45.4 [13.3]	67.1 [19.7]	60.6 [17.7]	55.5 [16.3]	75.3 [22.1]	69.6 [20.4]	63.9 [18.7]	66.3 [19.4]	67.2 [19.7]	
	Power	9.6	9.4	9.3	9.5	9.3	9.2	9.4	9.2	9.1	9.0	9.3	9.1
150 [64.7]	Total BTUH [kW]	83.2 [24.4]	79.8 [23.4]	77.2 [22.6]	78.1 [22.9]	74.9 [22.0]	72.5 [21.3]	71.6 [21.0]	68.7 [19.8]	66.4 [19.5]	62.9 [18.4]	63.5 [18.6]	
	Sens BTUH [kW]	53.0 [15.5]	47.8 [14.0]	43.8 [12.8]	65.2 [19.1]	58.8 [17.2]	53.9 [15.8]	71.6 [21.0]	67.9 [19.9]	62.3 [18.2]	62.9 [18.4]	63.5 [18.6]	
155 [67.3]	Power	10.1	9.9	9.8	10.0	9.8	9.7	9.9	9.7	9.6	9.5	9.8	9.6

DR —Depression ratio  
dBE —Entering air dry bulb  
wBE —Entering air wet bulb

Total —Total capacity x 1000 BTUH  
Sens —Sensible capacity x 1000 BTUH  
Power —kW input

NOTES: ① When the entering air dry bulb is other than 80°F [27°C], adjust the sensible capacity from the table by adding [1.10 x CFM x (1 - DR) x (dBE - 80)].

[ ] Designates Metric Conversions

# COOLING PERFORMANCE DATA—RAWL -091 + RHGL -120Z

wBE CFM [L/s]		ENTERING INDOOR AIR @ 80°F [26.7°C] dbE ①										61°F [16.1°C]		59°F [15.0°C]	
		71°F [21.7°C]	67°F [19.4°C]	63°F [17.2°C]	61°F [16.1°C]	59°F [15.0°C]	3360 [1586]	2800 [1321]	2240 [1057]	3360 [1586]	2800 [1321]	2240 [1057]	3360 [1586]	2800 [1321]	2240 [1057]
DR ①		0.14	0.11	0.08	0.08	0.14	0.11	0.08	0.14	0.11	0.08	0.14	0.11	0.08	
75 [23.9]	Total BTUH [kW]	109.4 [32.1]	105.5 [30.9]	101.7 [29.8]	97.0 [28.4]	97.8 [28.7]	94.4 [27.7]	90.9 [26.7]	94.0 [27.5]	90.7 [26.6]	87.4 [25.6]	89.8 [26.3]	86.6 [25.4]	83.5 [24.5]	
	Sens BTUH [kW] Power	65.3 [19.1] 6.1	59.7 [17.5] 6.0	54.1 [15.9] 5.9	64.1 [18.8] 5.8	87.3 [25.6] 5.9	97.8 [28.7] 5.9	79.8 [23.4] 5.8	72.4 [21.2] 5.7	91.4 [26.8] 5.8	83.6 [24.5] 5.7	75.8 [22.2] 5.6	89.8 [26.3] 5.8	86.6 [25.4] 5.7	78.8 [23.1] 5.6
80 [26.7]	Total BTUH [kW]	108.2 [31.7]	104.4 [30.6]	100.6 [29.5]	95.9 [28.1]	96.6 [28.3]	93.2 [27.3]	89.8 [26.3]	92.8 [27.2]	89.5 [26.2]	86.3 [25.3]	88.6 [26.0]	85.5 [25.0]	82.4 [24.1]	
	Sens BTUH [kW] Power	64.7 [19.0] 6.4	59.2 [17.3] 6.3	53.7 [15.7] 6.2	63.7 [18.7] 6.1	86.7 [25.4] 6.2	96.6 [28.3] 6.2	79.3 [23.2] 6.1	71.9 [21.1] 6.0	90.9 [26.6] 6.1	83.1 [24.4] 6.0	75.3 [22.1] 5.9	88.6 [26.0] 6.1	85.5 [25.0] 6.0	78.4 [23.0] 5.9
85 [29.4]	Total BTUH [kW]	106.7 [31.3]	102.9 [30.2]	99.2 [29.1]	94.5 [27.7]	95.1 [27.9]	91.7 [26.9]	88.4 [25.9]	91.3 [26.7]	88.1 [25.8]	84.9 [24.9]	87.1 [25.5]	84.0 [24.6]	81.0 [23.7]	
	Sens BTUH [kW] Power	64.0 [18.8] 6.7	58.5 [17.2] 6.6	53.1 [15.5] 6.5	63.1 [18.5] 6.4	86.0 [25.2] 6.5	95.1 [27.9] 6.5	78.6 [23.0] 6.4	71.3 [20.9] 6.3	90.2 [26.4] 6.5	82.5 [24.2] 6.4	74.8 [21.9] 6.2	87.1 [25.5] 6.4	84.0 [24.6] 6.3	77.8 [22.8] 6.2
90 [32.2]	Total BTUH [kW]	104.9 [30.7]	101.2 [29.7]	97.5 [28.6]	92.8 [27.2]	93.3 [27.3]	90.0 [26.4]	86.8 [25.4]	89.5 [26.2]	86.3 [25.3]	83.2 [24.4]	85.3 [25.0]	82.3 [24.1]	79.3 [23.2]	
	Sens BTUH [kW] Power	63.1 [18.5] 7.1	57.7 [16.9] 7.0	52.4 [15.3] 6.8	62.4 [18.3] 6.7	85.1 [24.9] 6.9	93.3 [27.3] 6.9	77.9 [22.8] 6.8	70.6 [20.7] 6.6	89.3 [26.2] 6.8	81.7 [23.9] 6.7	74.0 [21.7] 6.6	85.3 [25.0] 6.8	82.3 [24.1] 6.7	77.1 [22.6] 6.5
95 [35]	Total BTUH [kW]	102.8 [30.1]	99.2 [29.1]	95.6 [28.0]	90.9 [26.6]	91.3 [26.7]	88.1 [25.8]	84.9 [24.9]	87.4 [25.6]	84.4 [24.7]	81.3 [23.8]	83.2 [24.4]	80.3 [23.5]	77.4 [22.7]	
	Sens BTUH [kW] Power	62.1 [18.2] 7.5	56.8 [16.7] 7.3	51.5 [15.1] 7.2	61.5 [18.0] 7.1	84.1 [24.7] 7.3	91.3 [26.7] 7.3	76.9 [22.5] 7.1	69.8 [20.4] 7.0	87.4 [25.6] 7.2	80.8 [23.7] 7.1	73.2 [21.5] 7.0	83.2 [24.4] 7.2	80.3 [23.5] 7.0	76.2 [22.3] 6.9
100 [37.8]	Total BTUH [kW]	100.5 [29.5]	97.0 [28.4]	93.5 [27.4]	88.8 [26.0]	88.9 [26.1]	85.8 [25.1]	82.7 [24.2]	85.1 [24.9]	82.1 [23.4]	79.1 [23.2]	80.9 [23.7]	78.1 [22.9]	75.2 [22.0]	
	Sens BTUH [kW] Power	61.0 [17.9] 7.9	55.8 [16.3] 7.7	50.6 [14.8] 7.6	60.6 [17.7] 7.5	83.0 [24.3] 7.7	88.9 [26.1] 7.7	75.9 [22.2] 7.5	68.8 [20.2] 7.4	85.1 [24.9] 7.6	79.7 [23.4] 7.5	72.3 [21.2] 7.3	80.9 [23.7] 7.6	78.1 [22.9] 7.4	75.2 [22.0] 7.3
105 [40.6]	Total BTUH [kW]	97.9 [28.7]	94.5 [27.7]	91.0 [26.7]	86.4 [25.3]	86.3 [25.3]	83.3 [24.4]	80.3 [23.5]	82.5 [24.2]	79.6 [23.3]	76.7 [22.5]	78.3 [23.0]	75.6 [22.1]	72.8 [21.3]	
	Sens BTUH [kW] Power	59.7 [17.5] 8.3	54.6 [16.0] 8.2	49.5 [14.5] 8.0	59.5 [17.4] 7.9	81.7 [23.9] 8.1	86.3 [25.3] 8.1	74.7 [21.9] 7.9	67.7 [19.8] 7.8	82.5 [24.2] 8.0	78.5 [23.0] 7.9	71.2 [20.9] 7.8	78.3 [23.0] 8.0	75.6 [22.1] 7.8	72.8 [21.3] 7.7
110 [43.3]	Total BTUH [kW]	95.0 [27.9]	91.7 [26.9]	88.4 [25.9]	83.7 [24.5]	83.5 [24.5]	80.5 [23.6]	77.6 [22.7]	79.6 [23.3]	76.9 [22.5]	74.1 [21.7]	75.5 [22.1]	72.8 [21.3]	70.2 [20.6]	
	Sens BTUH [kW] Power	58.2 [17.1] 8.7	53.3 [15.6] 8.6	48.3 [14.2] 8.4	58.3 [17.1] 8.3	80.2 [23.5] 8.5	83.5 [24.5] 8.5	73.4 [21.5] 8.4	66.5 [19.5] 8.2	79.6 [23.3] 8.5	76.9 [22.5] 8.3	70.0 [20.5] 8.2	75.5 [22.1] 8.4	72.8 [21.3] 8.3	70.2 [20.6] 8.1
115 [46.1]	Total BTUH [kW]	91.9 [26.9]	88.7 [26.0]	85.4 [25.0]	80.8 [23.7]	80.3 [23.5]	77.5 [22.7]	74.7 [21.9]	76.5 [22.4]	73.8 [21.6]	71.1 [20.8]	72.3 [21.2]	69.8 [20.4]	67.2 [19.7]	
	Sens BTUH [kW] Power	56.6 [16.6] 9.2	51.8 [15.2] 9.0	47.0 [13.8] 8.9	57.0 [16.7] 8.8	78.6 [23.0] 9.0	80.3 [23.5] 9.1	71.9 [21.1] 8.8	65.2 [19.1] 8.7	76.5 [22.4] 8.9	73.8 [21.6] 8.8	68.7 [20.1] 8.6	72.3 [21.2] 8.9	69.8 [20.4] 8.7	67.2 [19.7] 8.6
120 [48.9]	Total BTUH [kW]	88.5 [25.9]	85.4 [25.0]	82.3 [24.1]	77.6 [22.7]	76.9 [22.5]	74.2 [21.7]	71.5 [21.0]	73.1 [21.4]	70.5 [20.7]	68.0 [19.9]	68.9 [20.2]	66.5 [19.5]	64.1 [18.8]	
	Sens BTUH [kW] Power	54.9 [16.1] 9.7	50.2 [14.7] 9.5	45.5 [13.3] 9.4	55.5 [16.3] 9.3	76.9 [22.5] 9.5	76.9 [22.5] 9.5	70.3 [20.6] 9.3	63.8 [18.7] 9.1	73.1 [21.4] 9.4	70.5 [20.7] 9.3	67.2 [19.7] 9.1	68.9 [20.2] 9.4	66.5 [19.5] 9.2	64.1 [18.8] 9.0
125 [51.7]	Total BTUH [kW]	84.8 [24.8]	81.8 [24.0]	78.8 [23.1]	74.2 [21.7]	73.2 [21.5]	70.7 [20.7]	68.1 [20.0]	69.4 [20.3]	67.0 [19.6]	64.5 [18.9]	65.2 [19.1]	62.9 [18.4]	60.6 [17.8]	
	Sens BTUH [kW] Power	53.0 [15.5] 10.2	48.5 [14.2] 10.0	44.0 [12.9] 9.8	54.0 [15.8] 9.7	73.2 [21.5] 10.0	73.2 [21.5] 10.0	68.6 [20.1] 9.8	62.2 [18.2] 9.6	69.4 [20.3] 9.9	67.0 [19.6] 9.8	64.5 [18.9] 9.6	65.2 [19.1] 9.9	62.9 [18.4] 9.7	60.6 [17.8] 9.5

DR —Depression ratio  
dbE —Entering air dry bulb  
wBE —Entering air wet bulb

Total —Total capacity x 1000 BTUH  
Sens —Sensible capacity x 1000 BTUH  
Power —KW input

NOTES: ① When the entering air dry bulb is other than 80°F [27°C], adjust the sensible capacity from the table by adding [(1 - DR) x (dbE - 80)].

[ ] Designates Metric Conversions

# TYPICAL REFRIGERANT PIPING RECOMMENDATIONS

## General Notes:

1. Vertical risers not to exceed 60 feet [18.29 m].
2. Locate the condensing unit and evaporator(s) as close together as possible to minimize piping runs.
3. Condensing units are shipped with a nitrogen holding charge. Evacuate condensing unit before charging with refrigerant.

EQUIVALENT LENGTH (FT.) [m] OF STRAIGHT TYPE "L" TUBING FOR NON-FERROUS VALVES & FITTINGS (BRAZED)						
TUBE SIZE, INCHES [mm] O.D.	SOLENOID VALVE	ANGLE VALVE	SHORT RADIUS ELL	LONG RADIUS ELL	TEE LINE FLOW	TEE BRANCH FLOW
1/2 [13.00]	12 [3.7]	8.3 [2.5]	1.6 [0.5]	1.0 [0.3]	1.0 [0.3]	3.1 [0.9]
5/8 [16.00]	15 [4.6]	10.4 [3.2]	1.9 [0.6]	1.2 [0.4]	1.2 [0.4]	3.6 [1.1]
3/4 [19.00]	18 [5.5]	12.5 [3.8]	2.1 [0.7]	1.4 [0.4]	1.4 [0.4]	4.2 [1.3]
7/8 [22.00]	21 [6.4]	14.6 [4.4]	2.4 [0.7]	1.6 [0.5]	1.6 [0.5]	4.8 [1.5]
1 1/8 [29.00]	12 [3.7]	18.8 [5.7]	3.0 [0.9]	2.0 [0.6]	2.0 [0.6]	6.0 [1.8]
1 3/8 [35.00]	15 [4.6]	22.9 [7.0]	3.6 [1.1]	2.4 [0.7]	2.4 [0.7]	7.2 [2.2]
1 5/8 [41.00]	18 [5.5]	27.1 [8.3]	4.2 [1.3]	2.8 [0.8]	2.8 [0.8]	8.4 [2.6]
2 5/8 [54.00]	21 [6.4]	35.4 [10.8]	5.3 [1.6]	3.5 [1.1]	3.5 [1.1]	10.7 [3.3]

RECOMMENDED VAPOR AND LIQUID LINE SIZES FOR VARIOUS LENGTHS OF RUN				
LINEAR LENGTH (FT.) [m]	LIQUID LINE O.D. SIZES (IN.) [mm]		VAPOR LINE O.D. SIZES (IN.) [mm]	
	079	091*	079	091
0-15 [0-4.57]	1/2 [12.7]	1/2 [12.7]	1 1/8 [28.58]	1 1/8 [28.58]
16-50 [4.88-15.24]	1/2 [12.7]	1/2 [12.7]	1 1/8 [28.58]	1 1/8 [28.58]
51-100 [15.54-30.48]	1/2 [12.7]	1/2 [12.7]	1 1/8 [28.58]	1 3/8 [34.93]
101-150 [30.78-45.72]	1/2 [12.7]	1/2 [12.7]	1 3/8 [34.93]	1 3/8 [34.93]

**NOTE:** Runs between condenser and evaporator not to exceed 150' [45.7 m] linear length.

\*See note ④ under liquid line pressure drop chart. Use 5/8" [15.88 mm] liquid line with solenoid valve.

**LIQUID LINE PRESSURE DROP PER 100 FEET [30.48 m] EQUIVALENT LENGTH (TYPE L COPPER TUBING)**

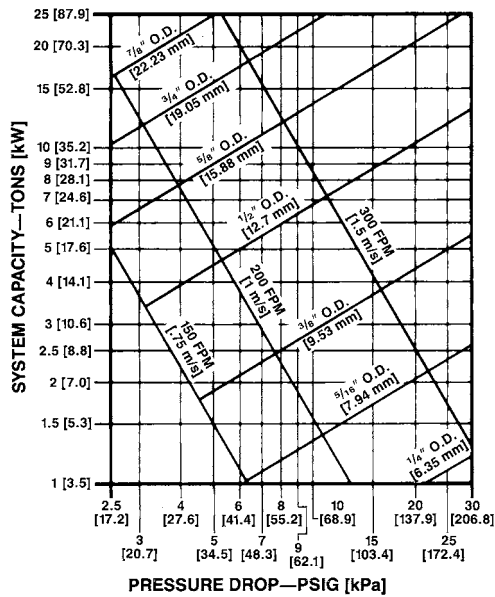

**NOTES:**

- 1) When evaporator coil is above condenser, the pressure drop due to vertical lift (.5 PSIG per foot of lift) [1.05 kPa per meter] **must** be added to the pressure drop derived from this curve.
- 2) Size liquid line for **no more** than 10°F [5.6°C] loss (approximately 50 PSIG [344.7 kPa] total pressure drop).
- 3) **Do not oversize liquid line.** Oversized liquid lines add significantly to the amount of refrigerant required to charge the system.
- 4) The maximum recommended velocity with solenoid valves or other quick closing devices in the liquid line is 300 FPM [1.5 m/s].

## COIL ABOVE CONDENSING UNIT

**NOTE: SOLENOID VALVE IS TO BE WIRED FOR ISOLATION ONLY, NOT PUMP DOWN.**

**VAPOR LINE SYSTEM CAPACITY LOSS IN PERCENT PER 100 FEET [30.48 m] EQUIVALENT LENGTH (TYPE L COPPER TUBING)**

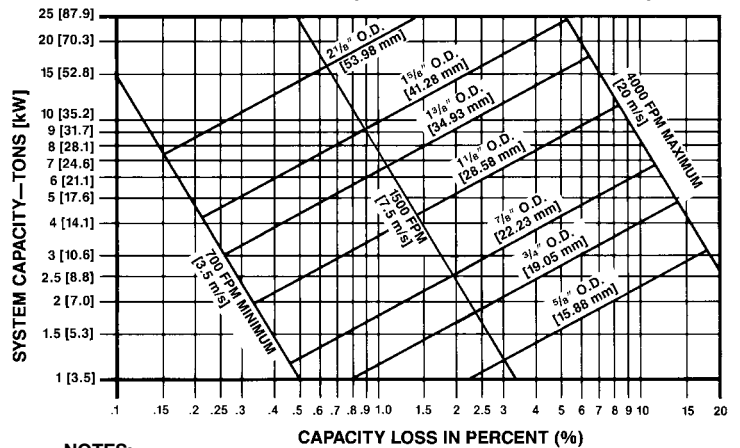

**NOTES:**

- 1) The minimum velocity line (700 fpm) [3.6 m/s] is recommended.
- 2) For vapor pressure drop (PSIG) [6.9 kPa], multiply percent (%) loss by 1.18.
- 3) Size vapor lines for no more than 2°F [1.1°C] loss which corresponds to approximately 5 PSIG [34.4 kPa] pressure drop.
- 4) Pitch all horizontal vapor lines downward in the direction of flow (1/2" [12.7 mm] to 10' [3.0 m] run).

## WARNING

**Do not use oxygen to purge lines or pressure system for leak test. Oxygen reacts violently with oil, which can cause an explosion resulting in severe personal injury or death.**

[ ] Designates Metric Conversions



## TYPICAL REFRIGERANT PIPING RECOMMENDATIONS (cont.)

### REQUIRED OZS. R-410A CHARGE PER FT. [m] OF TUBING

TUBE SIZE O.D. (IN.) [mm]	LIQUID (OZ.) [g]	VAPOR (OZ.) [g]
1/2 [12.7]	1.06 [30.0]	.04 [1.13]
5/8 [15.88]	1.65 [46.7]	.07 [1.98]
3/4 [19.05]	2.46 [69.7]	.10 [2.83]
7/8 [22.23]	3.28 [92.9]	.13 [3.68]
1 1/8 [28.58]		.22 [6.23]
1 3/8 [34.93]		.34 [9.63]
1 5/8 [41.28]		.48 [13.60]
2 1/8 [53.98]		.84 [23.81]

Quantities based on 110°F liquid and 45°F vapor.

## GENERAL INSTALLATION

The condensing unit should be installed outdoors. It should be located as near as possible to the evaporator section to keep connecting refrigerant tubing lengths to a minimum. The unit must be installed to allow a free air flow to the condenser coils.

If several units are installed adjacent to each other, care must be taken to avoid recirculation of air from one condenser to another. In all installations, adequate space must be provided for installation and servicing.

### BASIC SYSTEM CHARGE\*

UNIT MODEL	BASIC SYSTEM CHARGE, OZ, [g]*
RAWL-079	219 [6209]
RAWL-091	400 [11340]

\*System with 0 feet [m] of tubing.

[ ] Designates Metric Conversions

## GUIDE SPECIFICATIONS

Furnish and install as shown on the drawing Fujitsu Model \_\_\_\_\_ air cooled condensing unit suitable for outdoor application.

**COMPRESSOR**—Unit shall have (1) compressor. It is to be of the welded hermetic type with durable insulation on the motor windings. It shall be externally mounted on rubber grommets to reduce vibration transmission and noise to surrounding area. Maximum power input shall not be more than \_\_\_\_\_ on 6.5 nominal ton [22.86 kW] units and \_\_\_\_\_ on 7.5 nominal ton [26.38 kW] units \_\_\_\_\_ at conditions specified.

**LOW AMBIENT CONTROL**—All units shall have standard head pressure controls that cycle the condenser fan motors to maintain condensing pressures for operation down to 0°F [°C] ambient.

**CAPACITY**—Capacity shall be \_\_\_\_\_ BTU/HR when operating at \_\_\_\_\_ °F [°C] saturated suction temperature.

**MOTORS & FANS**—Each unit shall have one (6.5 & 7.5 ton) [22.86 & 26.38 kW] sleeve bearing, permanently lubricated motor(s) fixed with direct-drive, multi-bladed fan(s). Motor(s) shall be equipped with inherent overload protection. Motor(s) & fan(s) shall be mounted on hinged top panel for easy access. Condenser air shall discharge vertically.

**COILS**—Coils shall be fabricated of 3/8" [9.53 mm] O.D. seamless copper tubing and aluminum fins with die-formed collars mechanically bonded to tubes arranged in a staggered pattern. All coils shall be submitted to an air pressure test of up to 300 PSIG after fabrication and dehydrated. Units shall be shipped with a dry nitrogen holding charge. Coil design shall permit

removal of service panels without affecting operation of the unit. Airflow shall be drawn through design providing uniform air distribution across the coil surface.

**CASINGS**—Casings shall make unit suitable for outdoor installation. Casing, base pan and framework shall be manufactured of galvanized sheet metal subjected to multistage cleaning, pre-treated and finished with a durable powder coat paint, capable of withstanding a 1000-HR salt spray test per ASTM B 117. Units shall have stamped louver panels offering 100% protection of the condenser coil face. Openings shall be provided for power. Dimensions of entire assembly shall be not more than \_\_\_\_\_ inches [mm] high, \_\_\_\_\_ inches [mm] long and \_\_\_\_\_ inches [mm] wide.

**REFRIGERATION CIRCUIT**—Shall include the compressor, the condenser coils, all internal refrigerant piping, a liquid line service valve. Refrigerant stubs shall be extended through the cabinet for external field connection without affecting accessibility to compressor compartment.

**CONTROL PANEL**—The panel shall be designed for single power source to the compressor and fan motor(s) and shall include low ambient fan cycling control, and compressor across-the-line contactor.

**SAFETY CONTROLS**—Manual reset high pressure and automatic reset low pressure control shall be provided.

**FACTORY TESTING**—All units shall be test run at the factory. They shall experience the following control testing procedures: high pressure control, switching of electrical components, and compressor operation.

**BEFORE PURCHASING THIS APPLIANCE, READ IMPORTANT ENERGY COST AND EFFICIENCY INFORMATION AVAILABLE FROM YOUR RETAILER.**

**GENERAL TERMS OF LIMITED WARRANTY\***

*Fujitsu General America, Inc.* will furnish a replacement for any part of this product which fails in normal use and service within the applicable periods stated, in accordance with the terms of the limited warranty.

Compressor .....Five (5) Years  
Any Other Part.....One (1) Year

**\*For complete details of the Limited and Conditional Warranties, including applicable terms and conditions, contact your local contractor or the Manufacturer for a copy of the product warranty certificate.**

---

**Before proceeding with installation, refer to installation instructions packaged with each model, as well as complying with all Federal, State, Provincial, and Local codes, regulations, and practices.**

---

*"In keeping with its policy of continuous progress and product improvement, the right is reserved to make changes without notice."*