



HTX & SXHT SERIES Hydronic Expansion Tanks

MATERIALS OF CONSTRUCTION

- Tank: 16-gauge cold rolled steel
- Finish: Appliance-quality paint for corrosion resistance
- Diaphragm Material: 100% butyl rubber
- Connection: Welded steel
- Testing: High pressure, seam weld, helium, final precharge check
- Air valve: Brass valve with O-ring seal
- Warranty: Five year

TYPICAL INSTALLATIONS

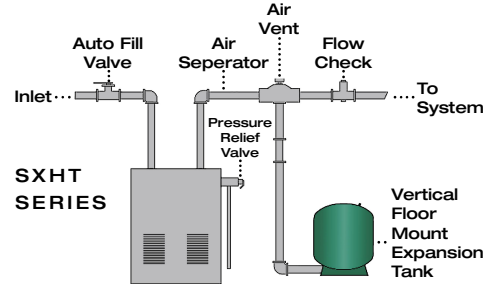
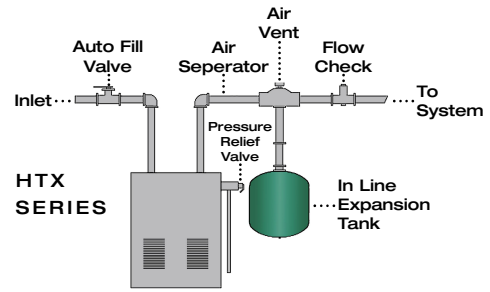

DIMENSIONS & CAPACITIES

Model	Capacity Gallons	Maximum Acceptance Volume	System Connection	Dimensions		
				Diameter	Height	Weight (lbs)
HTX 15	2.1	1.0	1/2" MNPT	8.0	12.5	5.5
HTX 30	4.5	2.5	1/2" MNPT	11.0	14.0	10.0
HTX 60	6.0	3.0	1/2" MNPT	11.4	17.2	11.5
HTX 90	15.0	6.0	3/4" MNPT	16.0	20.8	28.0
SXHT 30	15.0	6.0	1" FNPT	16.0	21.7	32.0
SXHT 40	20.0	8.0	1" FNPT	16.0	28.8	39.0
SXHT 60	33.0	13.3	1" FNPT	16.0	42.8	57.0
SXHT 90	44.0	17.7	1 1/4" FNPT	21.0	36.2	72.0
SXHT 110	62.0	24.9	1 1/4" FNPT	21.0	47.9	112.0
SXHT160	81.0	32.6	1 1/4" FNPT	21.0	62.0	123.0

Maximum working pressure 100 PSI. Factory pre-charge 12 PSI.
Maximum working temperature 240° F.

HTX SERIES

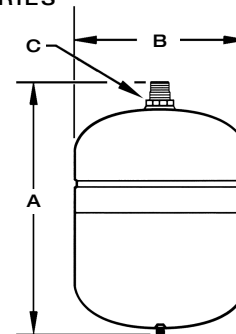

SXHT SERIES

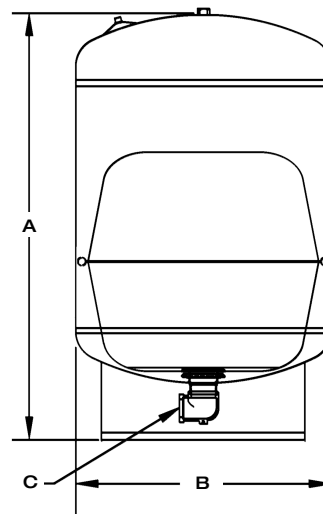

QUICK SIZING CHART

Boiler Output 1000's BTUH	Finned Tube Baseboard (Copper)	Type of Radiation		
		Convectors & Unit Htrs	Cast Iron	
			Radiators	Baseboard
25	HTX 15	HTX 15	HTX 15	HTX 15
50	HTX 15	HTX 30	HTX 30	HTX 30
75	HTX 30	HTX 30	HTX 60	HTX 60
100	HTX 30	HTX 30	HTX 60	HTX 60
125	HTX 30	HTX 60	HTX 60	HTX 60
150	HTX 30	HTX 60	HTX 90	HTX 90
175	HTX 60	HTX 60	HTX 90	HTX 90
200	HTX 60	HTX 60	HTX 90	HTX 90
250	SXHT 30	SXHT 30	SXHT 40	SXHT 30
300	SXHT 30	SXHT 40	SXHT 40	SXHT 30
350	SXHT 30	SXHT 40	SXHT 60	SXHT 40
400	SXHT 30	SXHT 60	SXHT 90	SXHT 40
500	SXHT 40	SXHT 60	SXHT 90	SXHT 40
600	SXHT 40	SXHT 90	SXHT 90	SXHT 60
700	SXHT 60	SXHT 90	SXHT 90	SXHT 60
800	SXHT 60	SXHT 110	SXHT 110	SXHT 90
900	SXHT 60	SXHT 110	SXHT 110	SXHT 90
1000	SXHT 90	SXHT 110	SXHT 110	SXHT 90

> www.flexconind.com
> 781-986-2424
> 300 Pond Street
> Randolph, MA 02368

