



FF_TT80M(X)

Parts List
30-October-2019



This parts list is current as of the above revision date.
www.fujitsugeneral.com

Form Number: 92-42814-FF_TT80M(X)

Table of Contents

Model Explanation	Page 3
Parts Numbers	
Panels - Miscellaneous (1)	Page 4
Electrical Group	Page 5
Blower Group	Page 5
Heat Exchanger-Burner Group	Page 6
Gas Controls	Page 6
Orifice Selection Chart	Page 7
Drawings/Photographs	
Exploded View	Page 8
Cabinet Interior	Page 9
Burner Assembly	Page 10
NOx Insert Assembly	Page 11
Junction Box	Page 12
Blower Shelf	Page 13
Blower Assembly	Page 14
Blower Mounting Plate	Page 15
Notes	Page 16

MODEL EXPLANATION

F	F	5	0	1	4	3	T	T	8	0	M
(1)		(2)		(3)		(4)	(5)	(6)	(7)		(8)

(1) TRADEBRAND IDENTIFICATION
FF = Fujitsu Furnace

(5) MOTOR TYPE
T = Constant Torque Premium

(2) HEATING INPUT DESIGNATION
050 = 50,000 BTU/HR
075 = 75,000 BTU/HR
100 = 98,000 BTU/HR
125 = 125,000 BTU/HR
150 = 150,000 BTU/HR

(6) STAGE - TWO

(7) SERIES
80% Efficient

(3) CABINET WIDTH
14 = 14.0 inch
17 = 17.5 inch
21 = 21.0 inch
24 = 24.5 inch

(8) STANDARD/NOx
M = Upflow/Horizontal - Standard
X = Upflow/Horizontal - Low NOx

(4) AIRFLOW
3 = Up to 3 tons
4 = Up to 4 tons
5 = Up to 5 tons

SERIAL NUMBER EXPLANATION

W	0	8	1	4	9	9	9	9
(1)	(2)		(3)		(4)			

(1) PLANT CODE

(2) WEEK (DATE CODE)

(3) YEAR

(4) PRODUCTION NUMBER

Note: For Gas Code, see Control System Gas Code on Rating Plate

No.	Notes	MODEL INPUT AIRFLOW CABINET WIDTH CONFIGURATION	FF	FF	FF	FF	FF	FF	FF
			50	75	75	100	100	125	150
			14	17	17	17	21	24	24
			3	3	4	4	5	5	5
			TT(80M/80X)	TT(80M/80X)	TT(80M/80X)	TT(80M/80X)	TT(80M/80X)	TT(80M/80X)	TT(80M/80X)
PANELS, SHEET METAL, AND MISCELLANEOUS									
1		Jacket Assembly	See Note 1						
1a		Star Bushing	45-18515-01	45-18515-01	45-18515-01	45-18515-01	45-18515-01	45-18515-01	45-18515-01
1b		Insulation - Foil Back	68-104821-05	68-104821-06	68-104821-06	68-104821-06	68-104821-07	68-104821-08	68-104821-08
1c		Insulation - Sound	68-103537-04	68-103537-01	68-103537-01	68-103537-01	68-103537-02	68-103537-03	68-103537-03
1d		Insulation Retainer (2)	AE-67925-01	AE-67925-01	AE-67925-01	AE-67925-01	AE-67925-01	AE-67925-01	AE-67925-01
2a		Top Plate Assembly (includes air deflector)	AS-104767-11	AS-104767-12	AS-104767-12	AS-104767-12	AS-104767-13	AS-104767-14	AS-104767-14
2b		Intake Air Deflector (attached to top plate)	AE-101077-02	AE-101077-01	AE-101077-01	AE-101077-01	AE-101077-01	AE-101077-01	AE-101077-01
2c		Left Jacket Baffle	AE-61606-01	AE-61606-01	AE-61606-01	AE-100548-01	AE-61668-01	AE-61665-01	N/A
2d		Right Jacket Baffle	AE-61606-01	AE-61606-01	AE-61606-01	AE-100548-01	AE-61668-01	AE-61665-01	N/A
2e		Rear Jacket Baffle	AE-61666-01	AE-61607-01	AE-61607-01	AE-61607-01	AE-61667-01	AE-61670-01	AE-61669-01
2f		Heat Exchanger Bracket - Left Side	See Heat Exchanger/Burner/Manifold Group						
2g		Heat Exchanger Bracket - Right Side	See Heat Exchanger/Burner/Manifold Group						
3		Burner Compartment Door - Upper Door	AS-104911-34	AS-104911-31	AS-104911-31	AS-104911-31	AS-104911-32	AS-104911-33	AS-104911-33
4		Blower/Filter Door - Lower Door	AS-104911-54	AS-104911-51	AS-104911-51	AS-104911-51	AS-104911-52	AS-104911-53	AS-104911-53
		Door Filler (with integral molded alignment pins)	68-104374-34	68-104374-31	68-104374-31	68-104374-31	68-104374-32	68-104374-33	68-104374-33
		Door Latch Kit (includes two of each: Latch Cam, Latch Handle, O-Ring, Retainer Screw)	PD644035	PD644035	PD644035	PD644035	PD644035	PD644035	PD644035
5		Sight Glass - Door (2)	68-21893-04	68-21893-04	68-21893-04	68-21893-04	68-21893-04	68-21893-04	68-21893-04
6a		Junction Box	AE-61475-03	AE-61475-03	AE-61475-03	AE-61475-03	AE-61475-03	AE-61475-03	AE-61475-03
6b		Juncton Box Cover	AE-61476-03	AE-61476-03	AE-61476-03	AE-61476-03	AE-61476-03	AE-61476-03	AE-61476-03
8		Exhaust Collar	Available as Accessory RXGW-C01						
11a		Bottom Plate Assembly (Platinum)	AS-104968-11	AS-104968-12	AS-104968-12	AS-104968-12	AS-104968-13	AS-104968-14	AS-104968-14
11b		Solid Bottom	AE-61874-01	AE-61874-02	AE-61874-02	AE-61874-02	AE-61874-03	AE-61874-04	AE-61874-04
12		Blower Shelf Assembly (includes items 12a, 12b,	AS-104809-01	AS-104809-02	AS-104809-02	AS-104809-02	AS-104809-04	AS-104809-05	AS-104809-05
12a		Bracket Door Mounting	AE-104332-04	AE-104332-01	AE-104332-01	AE-104332-01	AE-104332-02	AE-104332-03	AE-104332-03
12b		Gasket - Blower Shelf	68-104382-04	68-104382-01	68-104382-01	68-104382-01	68-104382-02	68-104382-03	68-104382-03
12c		Gasket - Door	AE-61951-53	AE-61951-54	AE-61951-54	AE-61951-54	AE-61951-55	AE-61951-56	AE-61951-56
12d		Stripping - Angle Bracket	AE-61951-57	AE-61951-58	AE-61951-58	AE-61951-58	AE-61951-59	AE-61951-60	AE-61951-60
12e		Stripping - Angle Bracket	AE-61951-62	AE-61951-62	AE-61951-62	AE-61951-62	AE-61951-62	AE-61951-62	AE-61951-62
12f		Angle Bracket	AE-104758-01	AE-104758-02	AE-104758-02	AE-104758-02	AE-104758-03	AE-104758-04	AE-104758-04
12g		Side Angle Assembly - Left (includes stripping)	AS-104923-01	AS-104923-01	AS-104923-01	AS-104923-01	AS-104923-01	AS-104923-01	AS-104923-01
12h		Side Angle Assembly - Right (includes stripping)	AS-104923-02	AS-104923-02	AS-104923-02	AS-104923-02	AS-104923-02	AS-104923-02	AS-104923-02
20a		Pressure Switch	See Electrical Group						
20b		Silicon Tubing - Pressure Switch	See Electrical Group						
21		Door Switch - Push Button	See Electrical Group						
22		Limit - Main Limit (Heat Exchanger Panel)	See Electrical Group						
23		Limit - Manual Reset (Burner Compartment)	See Electrical Group						
24		Transformer	See Electrical Group						
25		Induced Draft Blower (IDB)	See Electrical Group						
27		Capacitor - Blower Motor	See Electrical Group						
28		Strap - Blower Motor Capacitor	See Electrical Group						
29		Wire Assembly (Junction Box to Twist Lock)	See Electrical Group						
30		Blower Assembly	See Blower Group						
30a		Control Mounting Plate	See Blower Group						
31a		Housing w/Blower Wheel	See Blower Group						
31b		Blower Wheel	See Blower Group						
40		Heat Exchanger Assembly	See Heat Exchanger/Burner/Manifold Group						
42		Burner Assembly	See Heat Exchanger/Burner/Manifold Group						
43		Manifold (w/o Orifices)	See Heat Exchanger/Burner/Manifold Group						
50		Gas Valve	See Gas Controls						
51		Integrated Furnace Control Board (IFC)	See Gas Controls						
52		Flame Sensor	See Gas Controls						
53		Spark Ignitor	See Gas Controls						
		Touch-up Paint - Private Label Gray (Aerosol)	523014	523014	523014	523014	523014	523014	523014
		Touch-up Paint - Private Label Gray (Paint Pens)	523015	523015	523015	523015	523015	523015	523015

No.	Notes	MODEL INPUT AIRFLOW CABINET WIDTH CONFIGURATION	FF	FF	FF	FF	FF	FF	FF
			50	75	75	100	100	125	150
			14	17	17	17	21	24	24
			3	3	4	4	5	5	5
			TT(80M/80X)	TT(80M/80X)	TT(80M/80X)	TT(80M/80X)	TT(80M/80X)	TT(80M/80X)	TT(80M/80X)
ELECTRIC GROUP									
20a	Stk	Pressure Switch Assembly	42-106209-01	42-106209-01	42-106209-01	42-106209-01	42-106209-01	42-106209-01	42-106209-01
20b		Silicon Tubing - Pressure Switch	AE-61737-07	AE-61737-08	AE-61737-08	AE-61737-08	AE-61737-12	AE-61737-01	AE-61737-01
21		Door Switch - Push Button	42-22692-09	42-22692-09	42-22692-09	42-22692-09	42-22692-09	42-22692-09	42-22692-09
22	Stk	Limit - Main Limit (Heat Exchanger Panel)	47-104990-01	47-104990-03	47-104990-04	47-104990-05	47-25349-12	47-104990-04	47-104990-04
23	Stk	Limit - Manual Reset (Burner Compartment)	47-22861-03 (2)	47-22861-03 (2)	47-22861-03 (2)	47-22861-03 (2)	47-22861-03 (2)	47-22861-03 (2)	47-22861-03 (2)
23a	Stk	Limit - Heat Assisted (Blower Housing)	47-22860-06	47-22860-06	47-22860-06	47-22860-06	47-22860-06	47-22860-06	47-22860-06
		Bracket (Limit - Manual Reset)	See Heat Exchanger/Burner Manifold Group						
24	Stk	Transformer	46-24124-06	46-24124-06	46-24124-06	46-24124-06	46-24124-06	46-24124-06	46-24124-06
25	Stk	IDB - Induced Draft Blower (with Gasket)	70-101888-01	70-101888-01	70-101888-01	70-101888-01	70-101888-01	70-101888-02	70-101888-02
27	Stk	Capacitor - Blower Motor	N/A	N/A	N/A	N/A	N/A	N/A	N/A
28		Strap - Blower Motor Capacitor	N/A	N/A	N/A	N/A	N/A	N/A	N/A
		Blower Motor Harnesses	See Blower Group						
		Wiring Harness Assembly (Twist-Lock)	45-104932-01	45-104932-01	45-104932-01	45-104932-01	45-104932-01	45-104932-02	45-104932-02
29		Wire Assembly (Junction Box to Twist Lock)	45-24371-58	45-24371-58	45-24371-58	45-24371-58	45-24371-58	45-24371-58	45-24371-58
52		Flame Sensor	See Gas Controls						
53		Spark Ignitor	See Gas Controls						

No.	Notes	MODEL INPUT AIRFLOW CABINET WIDTH CONFIGURATION	FF	FF	FF	FF	FF	FF	FF
			50	75	75	100	100	125	150
			14	17	17	17	21	24	24
			3	3	4	4	5	5	5
			TT(80M/80X)	TT(80M/80X)	TT(80M/80X)	TT(80M/80X)	TT(80M/80X)	TT(80M/80X)	TT(80M/80X)
BLOWER GROUP									
30	Stk	Blower Assembly - Before W3619 (Includes items listed below except 23a, 30a):	AS-104614-13	AS-104614-14	AS-104614-15	AS-104614-16	AS-104614-17	AS-104614-18	AS-104614-19
30	Stk	Blower Assembly - On or After W3619 (Includes items listed below except 23a, 30a):	AS-104614-13	AS-104614-20	AS-104614-21	AS-104614-22	AS-104614-23	AS-104614-24	AS-104614-25
30a		Control Mounting Plate	AE-104878-02	AE-104878-02	AE-104878-02	AE-104878-02	AE-104878-02	AE-104878-02	AE-104878-02
23a		Limit - Heat Assisted (Blower Housing)	See Electric Group						
31a		Housing w/Blower Wheel	70-104182-11	70-104182-13	70-104182-13	70-104182-13	70-104182-17	70-104182-17	70-104182-17
31b	Stk	Blower Wheel	PD703025	PD703026	PD703026	PD703026	PD703028	PD703028	PD703028
32	Stk	Blower Motor - Before W3619	51-107164-01	51-106541-14	51-106542-13	51-106542-14	51-106542-15	51-106542-16	51-106542-17
32	Stk	Blower Motor - On or After W3619	51-107164-01	51-104355-14	51-104356-13	51-104356-14	51-104356-15	51-104356-16	51-104356-17
	Stk	Belly Band Motor Mount Kit (includes Motor Mount Arms, Belly Band and Mounting Hardware)	AS-53148-91	AS-53148-91	AS-53148-91	AS-53148-91	AS-53148-91	AS-53148-91	AS-53148-91
33		Motor Mount (Belly Band)	70-19927-04	70-19927-04	70-19927-04	70-19927-04	70-19927-04	70-19927-04	70-19927-04
34		Motor Mount Arm (4)	70-19929-10	70-19929-10	70-19929-10	70-19929-10	70-19929-10	70-19929-10	70-19929-10
35		Screw - Motor Mount Arm (4)	63-101978-01	63-101978-01	63-101978-01	63-101978-01	63-101978-01	63-101978-01	63-101978-01
		Motor Wiring Harness - Speed Plug	45-103551-02	45-103551-01	45-103551-01	45-103551-01	45-103551-01	45-103551-01	45-103551-01
		Motor Wiring Harness - Power Plug	45-105282-03	45-105282-01	45-105282-01	45-105282-01	45-105282-01	45-105282-01	45-105282-01

No.	Notes	MODEL INPUT AIRFLOW CABINET WIDTH CONFIGURATION	FF	FF	FF	FF	FF	FF	FF
			50 14 3 TT(80M/80X)	75 17 3 TT(80M/80X)	75 17 4 TT(80M/80X)	100 17 4 TT(80M/80X)	100 21 5 TT(80M/80X)	125 24 5 TT(80M/80X)	150 24 5 TT(80M/80X)
HEAT EXCHANGER, BURNER / MANIFOLD GROUP									
2f		Heat Exchanger Bracket - Left Side	AE-102680-01	AE-67846-02	AE-67846-02	AE-67846-02	AE-67846-02	AE-67846-02	AE-67846-02
2g		Heat Exchanger Bracket - Right Side	AE-102680-02	AE-67846-02	AE-67846-02	AE-67846-02	AE-67846-02	AE-67846-02	AE-67846-02
40	Stk	Heat Exchanger Assembly	AS-61579-14	AS-100560-01	AS-100560-01	AS-61579-07	AS-61579-04	AS-61579-05	AS-61579-06
40a		NOX Burner Inserts	AS-67875-01 (2)	AS-67875-01 (3)	AS-67875-01 (3)	AS-67875-01 (3)	AS-67875-01 (4)	AS-67875-01 (5)	AS-67875-01 (6)
40b		NOX Insert Retainer	AE-67872-01	AE-67872-02	AE-67872-02	AE-67872-02	AE-67872-03	AE-67872-04	AE-67872-05
42		Burner Assembly (Burner, Support, Brackets, Cover and Bottom Plates, Ignitor Bracket)	AS-104944-01	AS-104944-02	AS-104944-02	AS-104944-03	AS-104944-03	AS-104944-04	AS-104944-05
42		Burner Assembly - NOx variants (Burner, Support, Brackets, Cover and Bottom Plates, Ignitor Bracket)	AS-104944-11	AS-104944-12	AS-104944-12	AS-104944-13	AS-104944-13	AS-104944-14	AS-104944-15
42a	Stk	Burner	AS-60993-02	AS-60993-03	AS-60993-03	AS-60993-04	AS-60993-04	AS-60993-05	AS-60993-06
42b		Burner Support	AE-60997-01	AE-60997-02	AE-60997-02	AE-60997-03	AE-60997-03	AE-60997-04	AE-60997-05
42c		Burner Support Bracket (2)	AE-61588-02	AE-61588-02	AE-61588-02	AE-61588-02	AE-61588-02	AE-61588-02	AE-61588-02
42d		Burner Cover Plate	AE-101080-06	AE-101080-02	AE-101080-02	AE-101080-03	AE-101080-03	AE-101080-04	AE-101080-05
42d		Burner Cover Plate (NOx variants)	AE-101080-16	AE-101080-12	AE-101080-12	AE-101080-13	AE-101080-13	AE-101080-14	AE-101080-15
42e		Burner Bottom Plate	AE-104927-01	AE-104927-02	AE-104927-02	AE-104927-03	AE-104927-03	AE-104927-04	AE-104927-05
42f		Igniter Bracket	AE-61885-02	AE-61885-02	AE-61885-02	AE-61885-02	AE-61885-02	AE-61885-02	AE-61885-02
		Screw - Burner Assembly	63-22153-05 (13)	63-22153-05 (14)	63-22153-05 (14)	63-22153-05 (14)	63-22153-05 (15)	63-22153-05 (16)	63-22153-05 (17)
43		Manifold (w/o Orifices)	81-102427-01	81-102427-02	81-102427-02	81-102427-03	81-102427-03	81-102427-04	81-102427-05
		Burner Orifice - Natural Gas	See Orifice Selection Chart						
		Burner Orifice - LP	See Orifice Selection Chart						
		Number of Orifices	(2)	(3)	(3)	(4)	(4)	(5)	(6)

No.	Notes	MODEL GAS CODE	FFTT KS						
GAS CONTROLS									
50	Stk	Gas Valve - Natural Gas	60-101921-01						
	Stk,2	Gas Valve - LP	See Note 2						
51	Stk	Integrated Furnace Control Board (IFC)	62-106321-01						
52	Stk	Flame Sensor	62-23543-01						
53	Stk	Spark Ignitor	62-24164-03						
	Stk	LP Conversion Kit - U.S./Canadian Models	FP-32						

80% GAS FURNACE - ORIFICE SELECTION CHART - NATURAL GAS

CAUTION: Selection of the correct Natural Gas Orifice requires the following information for the specific installation:

- 1) Altitude in of the installation (ft.).
- 2) Average energy content of the Natural Gas fuel from the local supplier (BTU/cu. ft.).

For detailed information and instructions for Orifice selection, see the Gas Furnace LP Conversion Kit Index 92-21519-70 and the latest edition of the National Fuel Gas Code Handbook, or the National Standard of Canada, Natural Gas and Propane Installation Code, CAN B149.1.

CAUTION: This information is provided for replacement purposes only. Conversion for operation at High Altitude must be done using the kit specified on the product specification sheet for the unit.

NOTE: This Orifice sizing chart is based on 25,000 BTU/HR per burner.

NOTE: Factory installed orifices are calculated and sized based on a Natural Gas heating value of 1075 BTU/cu. ft. and an elevation of 0 - 3000 ft.

Energy Value (BTU/cu. ft.)	Elevation (ft.)							
	0 - 1999	2000 - 2999	3000 - 3999	4000 - 4999	5000 - 5999	6000 - 6999	7000 - 7999	8000 - 8999
850	62-22175-38	62-22175-39	62-22175-40	62-22175-41	62-22175-41	62-22175-42	62-22175-42	62-22175-43
900	62-22175-40	62-22175-41	62-22175-42	62-22175-42	62-22175-42	62-22175-43	62-22175-43	62-22175-44
975	62-22175-41	62-22175-42	62-22175-42	62-22175-42	62-22175-43	62-22175-43	62-22175-44	62-22175-44
1075	62-22175-42	62-22175-42	62-22175-43	62-22175-43	62-22175-43	62-22175-44	62-22175-44	62-22175-45
1170	62-22175-43	62-22175-44	62-22175-44	62-22175-44	62-22175-45	62-22175-45	62-22175-46	62-22175-47

80% GAS FURNACE - ORIFICE SELECTION CHART - LP

CAUTION: Selection of the correct LP Orifice requires the altitude of the specific installation (ft.).

For detailed information and instructions for Orifice selection, see the Gas Furnace LP Conversion Kit Index 92-21519-70 and the latest edition of the National Fuel Gas Code Handbook (NFG), or the National Standard of Canada, Natural Gas and Propane Installation Code, CAN B149.1.

CAUTION: This information is provided for replacement purposes only. Conversion to LP or for operation at High Altitude should be done using the kit(s) specified on the product specification sheet for the unit.

NOTE: This Orifice sizing chart is based on 25,000 BTU/HR per burner. Also, the chart is developed using the specified pressure setting of 10 in. water column instead of the 11.0 in water column used by the NFG and CANB149.1.

NOTE: Orifices supplied in the LP Conversion Kit are calculated and sized based on an altitude of 0 - 4000 ft.

Elevation (ft.)	Orifice							
0 - 2000	62-22175-54							
2001 - 3000	62-22175-54							
3001 - 4000	62-22175-54							
4001 - 5000	62-22175-54							
5001 - 6000	62-22175-54							
6001 - 7000	62-22175-54							
7001 - 8000	62-22175-55							
8001 - 9000	62-22175-55							
9001 - 10000	62-22175-55							

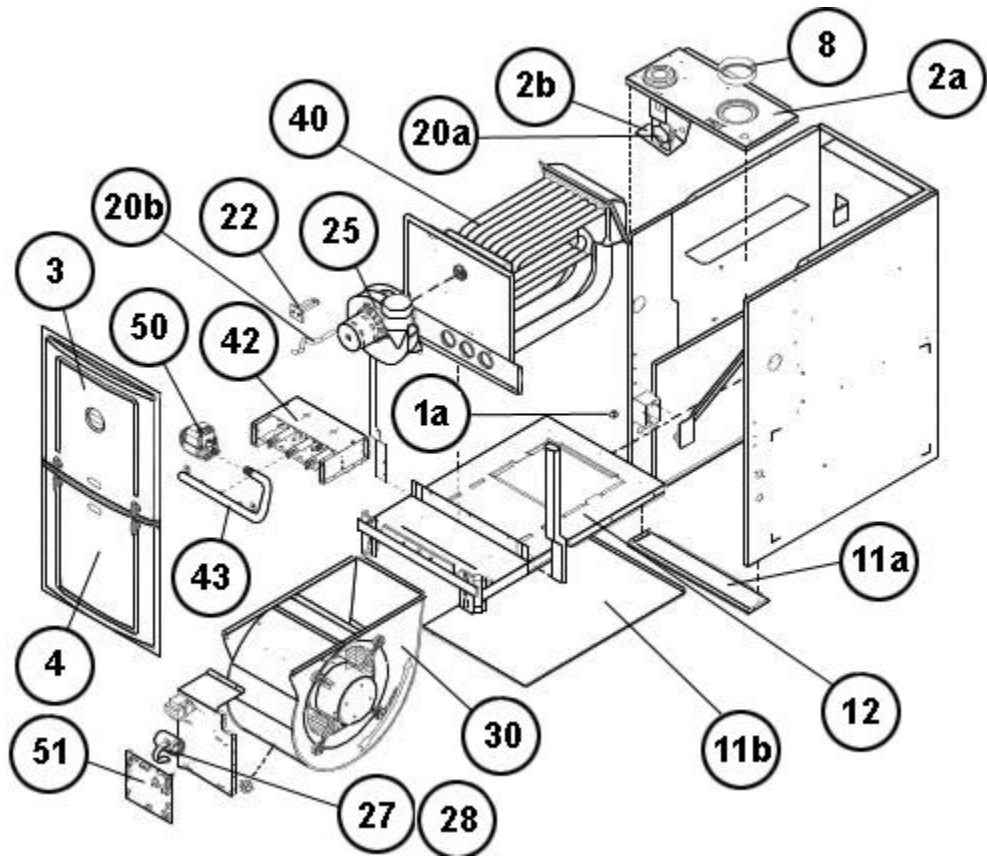

Exploded View

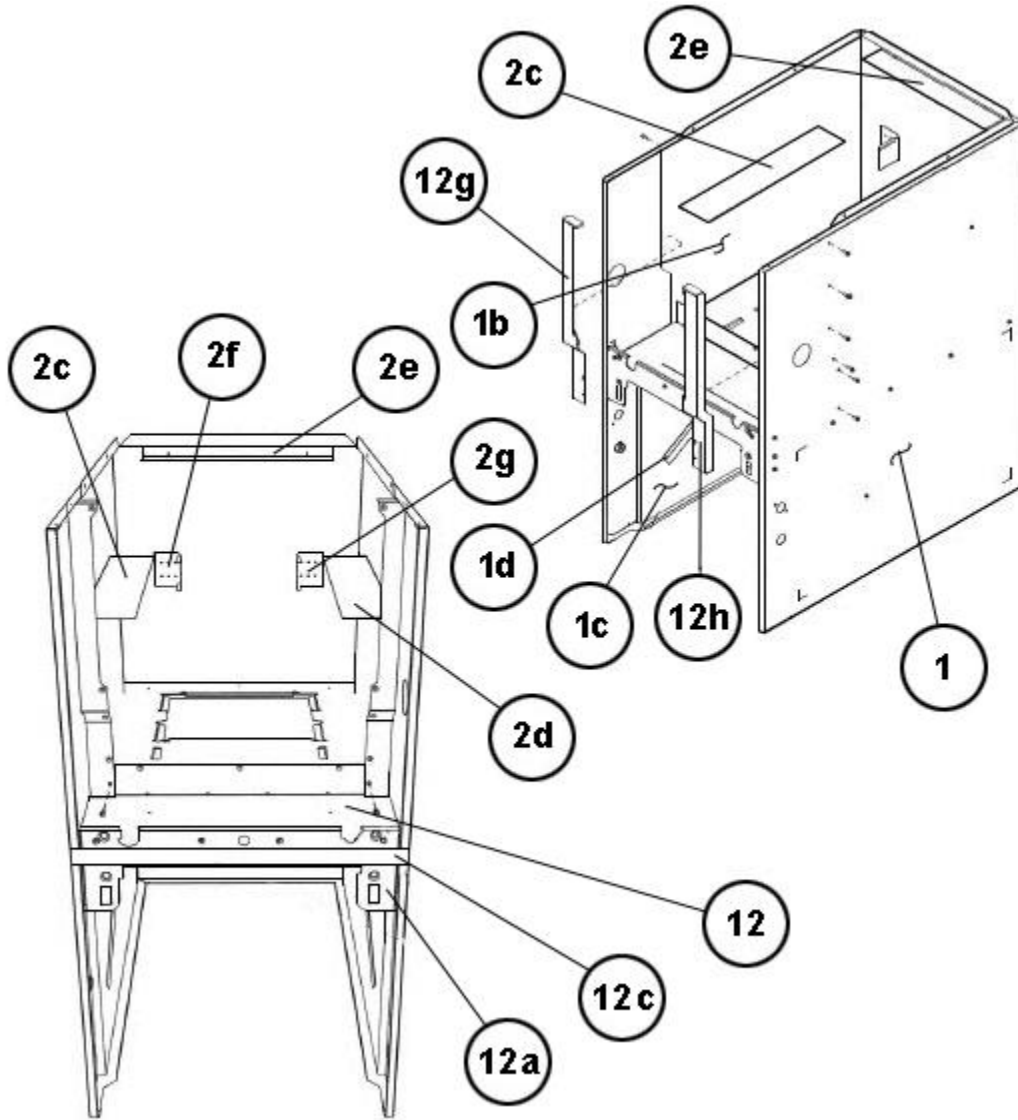

Cabinet Interior

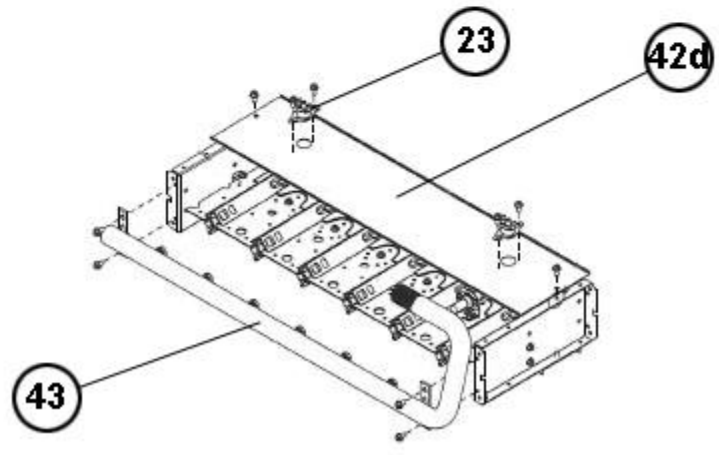
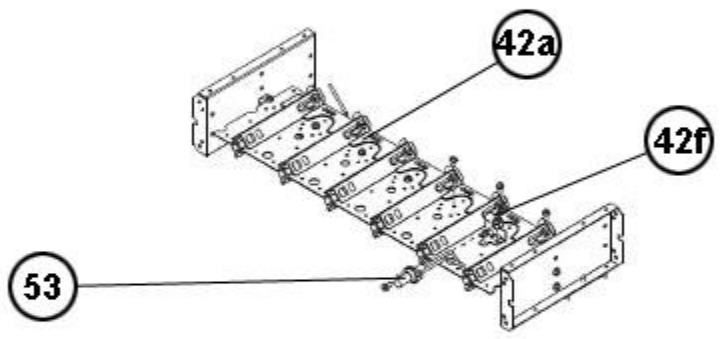
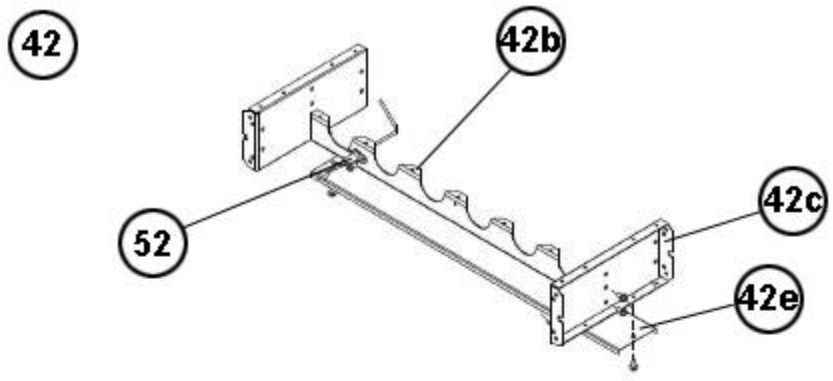

Burner Assembly

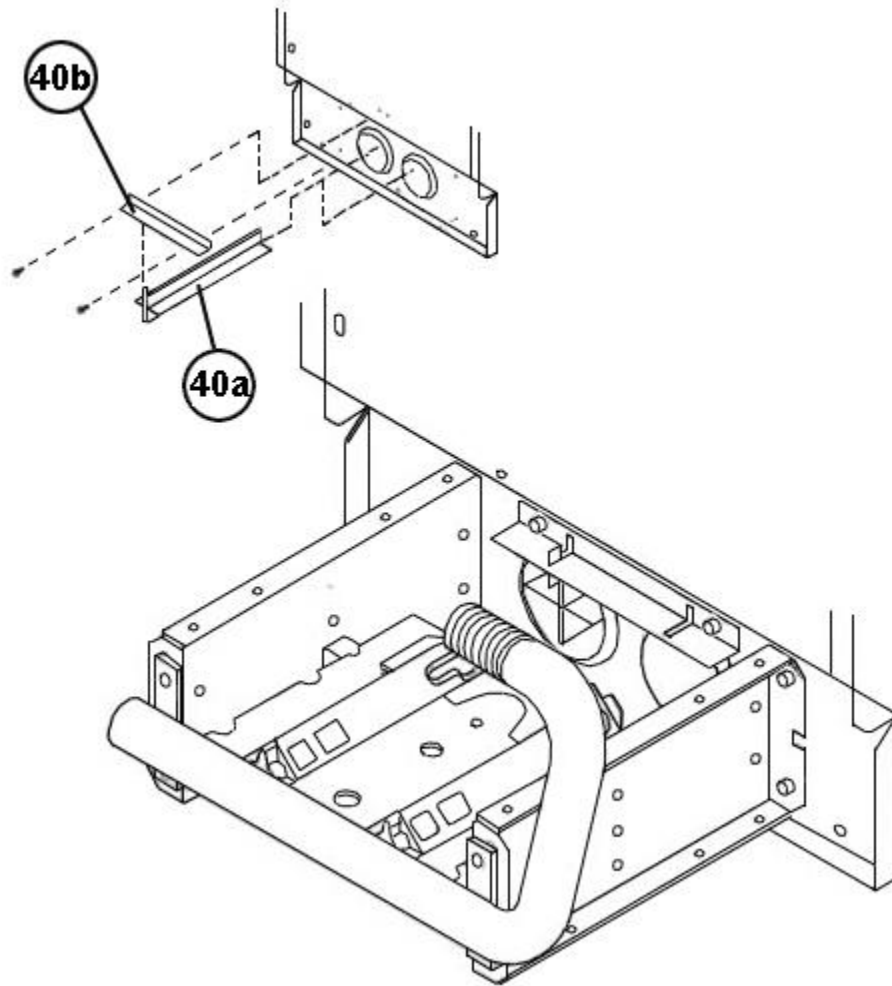

NOx Insert Assembly

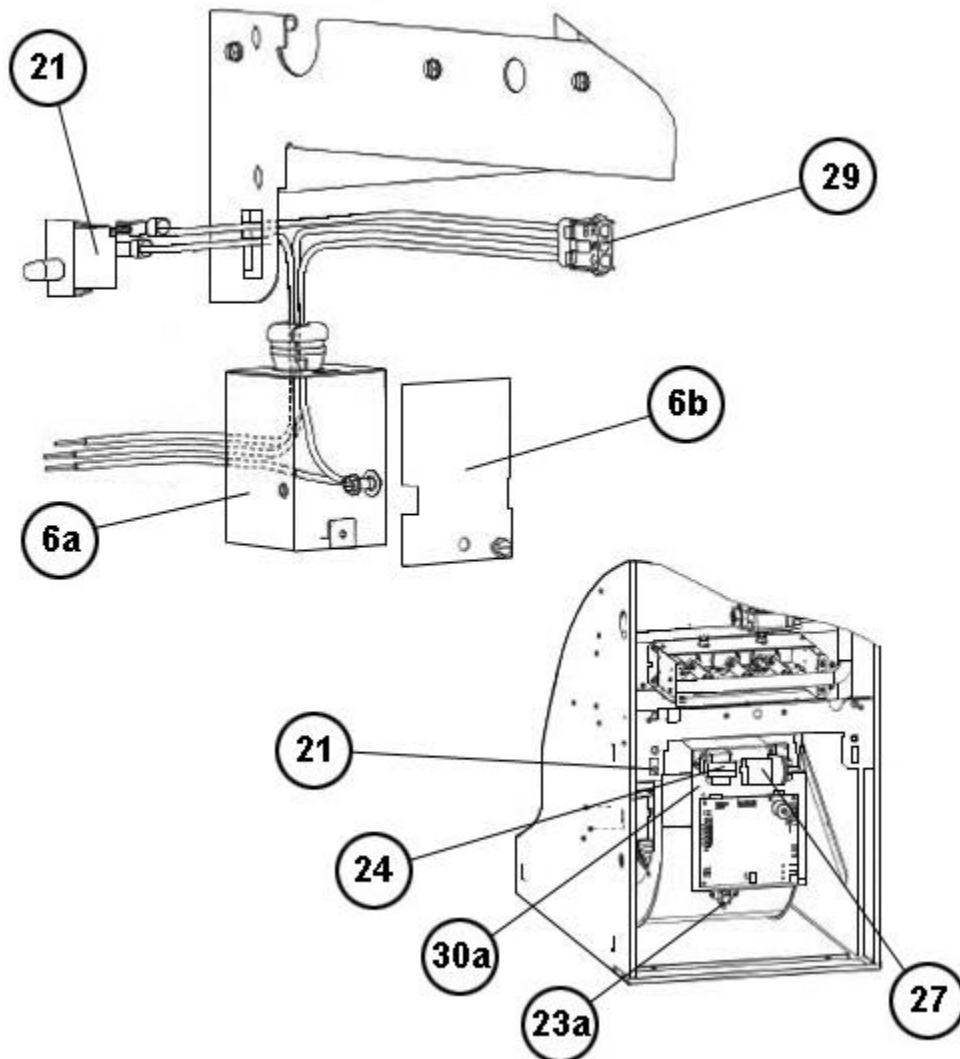

Junction Box

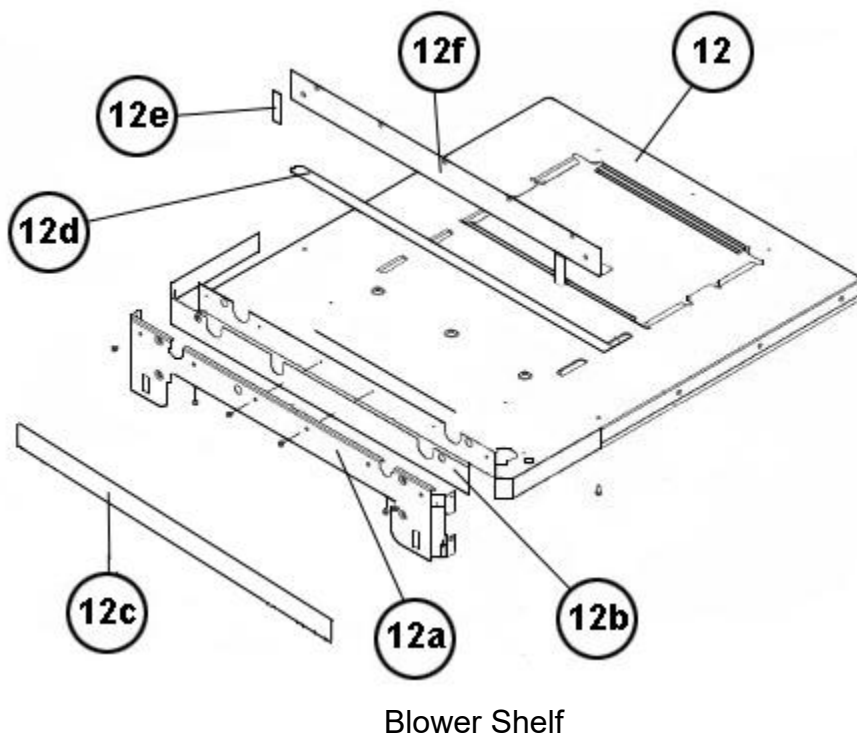

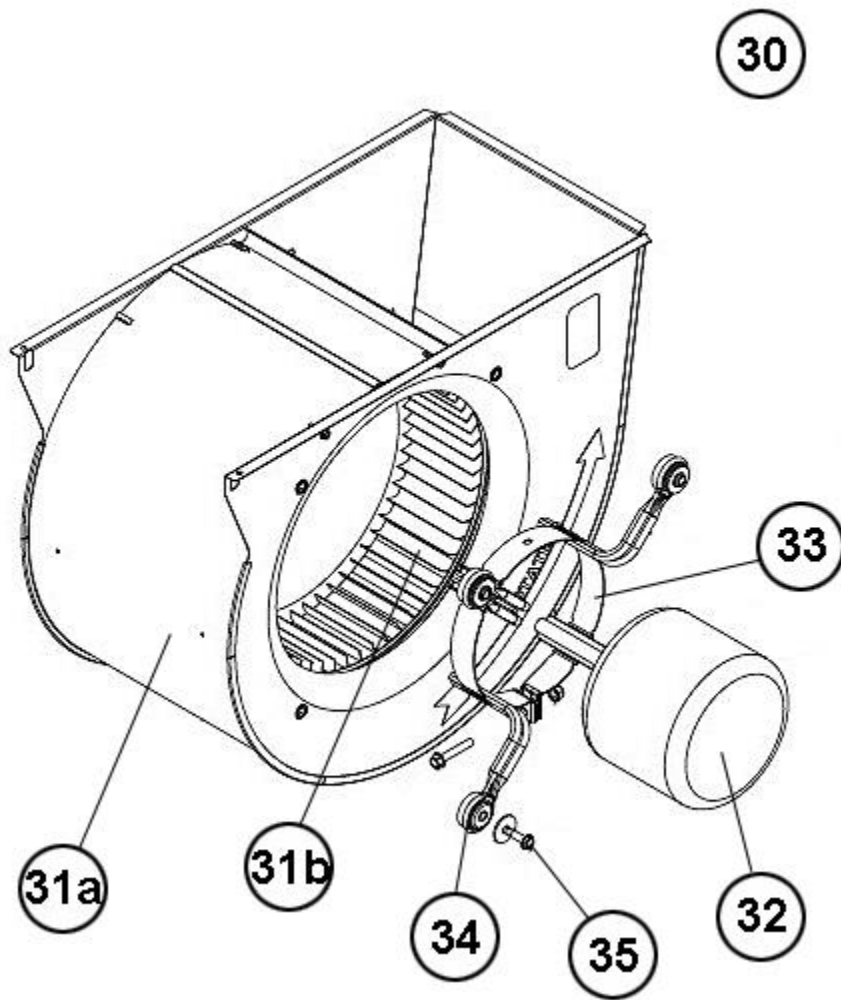

Blower Assembly

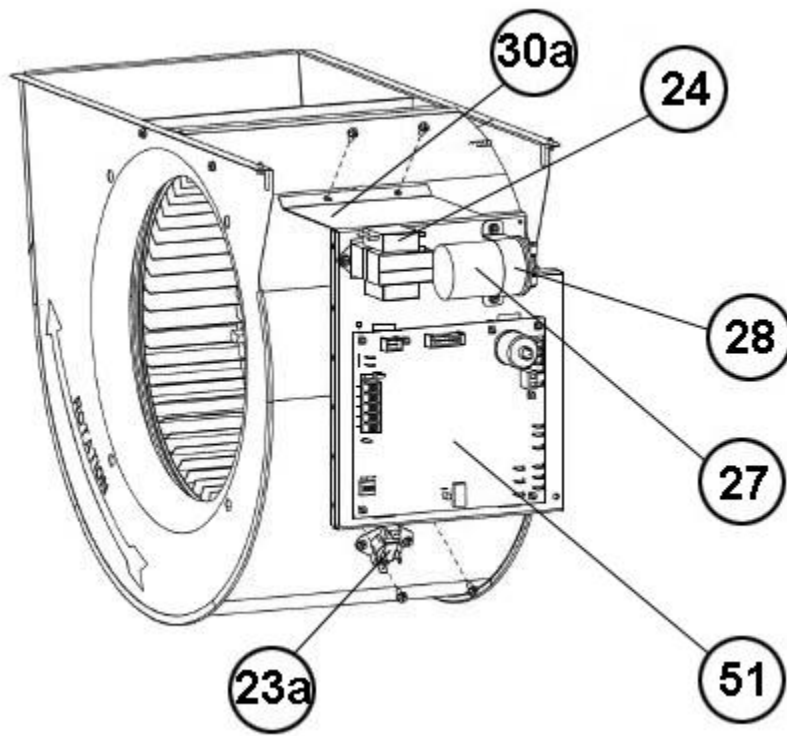

Blower Mounting Plate

NOTES

Stk It is recommended that stock be maintained for this part.

N/A Not Applicable

1 Jacket is not available for replacement.

2 Order Gas Valve for Natural Gas along with LP Conversion Kit.