



FAX-FAS Product Specification

DIRECT EXPANSION COMMERCIAL PACKAGED AIR-HANDLING UNITS, 6-30 TONS, 60 HZ, BUILT TO LAST, EASY TO INSTALL AND SERVICE

FAX/FAS air-handling units are the best choice for packaged air handlers. FAX/FAS units have direct-expansion coils, and FAX units come with X-Vane Fan Technology. All models offer excellent fan performance, a unique combination of indoor air quality features, and easy installation. Their versatility and state-of-the-art features provides economical performance.

Our easy-to install and economical FAX/FAS units provide reliable service and versatile packaged air-handling units satisfy design requirements with:

- Multi-position design for horizontal or vertical installation without modification.
- Standard sloped drain pans and cleanable insulation treated with an immobilized anti-microbial agent to inhibit the growth of bacteria and fungi on the insulation.
- High-static design meets a wider range of applications than competitive packaged air handler lines.
- Ultra Low Leak Economizer accessory provides ventilation air and “free” cooling with built in Fault Detection and Diagnostic (FDD) capabilities.
- Cooling coils with mechanically bonded fins provide peak heat transfer.
- Hot water coil, steam coil, and electric heat accessories are available.
- Standard factory-installed thermo-static expansion valves (TXV) with removable power element on FAX/FAS units.
- Die-formed galvanized steel casings provide durability and structural integrity. Optional paint is available.
- Upgraded unit control board with intuitive indoor fan adjustment.
- Standard 2-Speed Indoor Fan Motor system.

Easier installation and service

With the new X-Vane Axial fan system, there is no longer a need to adjust belts or pulleys as in past designs. This frees up maintenance and installation time.

The multi-position design and component layout allow for quick unit installation and operation. The DX coils have factory-installed TXVs with matching distributor nozzles. Units can be converted from horizontal to vertical operation by simply repositioning the unit. There are simple, fast plug-in connections to the standard integrated unit control board (UCB). The UCB has clearly labeled connection points to reduce installation time. Also, a large control box provides room to work and mount accessory controls.

Drain pan connections are duplicated on both sides of the unit. The filters, motor, drive, TXVs, and coil connections are easily accessed by removing a single side panel.

Easy to use

Our newly re-designed Unit Control Board puts all connections and troubleshooting points in one convenient place. Most low voltage connections are made to the same board and make it easy to access it. Setting up the fan is simple by an intuitive switch and rotary dial arrangement.

X-Vane Fan Technology

The direct drive X-Vane Fan Technology indoor fan system on FAX units uses a Vane Axial fan design and electronically commutated motors.

This new Vane Axial design over past belt drive systems has 75% fewer moving parts, uses up to 40% less energy and has no fan belts, blower bearings and shaft.

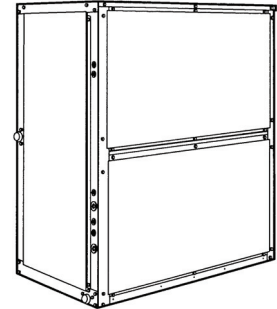

FAX072-120 unit shown

X-Vane Fan

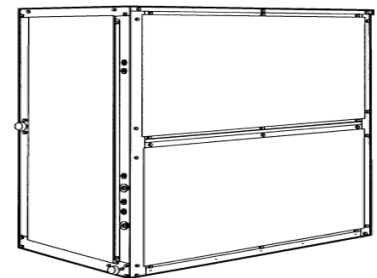

FAS150-336 unit shown

Table of contents

	PAGE		PAGE
FEATURES/BENEFITS	2	FAN DATA	28
MODEL NUMBER NOMENCLATURE	3	ELECTRICAL DATA	39
PHYSICAL DATA	6	TYPICAL PIPING AND WIRING DIAGRAMS	50
OPTIONS AND ACCESSORIES	9	APPLICATION DATA	55
BASE UNIT DIMENSIONS	11	GUIDE SPECIFICATIONS — FAX	56
ACCESSORY DIMENSIONS	16	GUIDE SPECIFICATIONS — FAS	59
PERFORMANCE DATA	23		

Features/Benefits

Rugged dependability

Die-formed galvanized steel panels ensure structural integrity under all operating conditions. Mechanically bonded coil fins provide improved heat transfer. For FAS units, galvanized steel fan housings are securely mounted to a die-formed galvanized steel deck. Rugged pillow-block bearings (FAS) are securely fastened to the solid steel fan shaft with split collets and clamp locking devices. FAX units have spider-type bearings.

This air handling unit has thermal insulation containing an immobilized anti-microbial agent to inhibit the growth of bacteria and fungi on the insulation.

Coil flexibility

FAX/FAS air handling units have galvanized steel casings; inlet and outlet connections are on the same end.

Direct-expansion (DX) coils are designed for use with R-410A refrigerant and have copper tubes mechanically bonded to aluminum sine-wave fins. DX coils include matched, factory-installed thermostatic expansion valves (TXVs) with matching distributor nozzles.

Indoor air quality features

The unique combination of features in the FAX/FAS Series air handlers ensures that clean, fresh, conditioned air is delivered to the occupied space.

Cooling coils prevent the build-up of humidity in the room, even during part-load conditions. Unit sizes 10 tons and above feature dual-circuit face-split coils.

2 in. (51 mm) disposable filters remove dust and airborne particles from the occupied space.

Pitched drain pan can be adjusted for a right-hand or left-hand connection to provide positive drainage and prevent standing condensate.

Economizer accessory precisely controls the blend of outdoor air and room air to achieve comfort levels. When the outside air is suitable, outside air dampers can fully open to provide “free” cooling. Economizer is an Ultra Low Leak design that includes return and outside air damper leakage that meets California Title 24 section 140.4 requirements. Controller meets California Title 24 Section 120.2 Fault Detection and Diagnostic (FDD) requirements.

Economy

The FAX/FAS packaged air handlers have low initial costs, and they continue to save money by providing reduced installation expense and energy-efficient performance.

Quick installation is ensured by the multi-position design. Units can be installed in either the horizontal or vertical (upflow) configuration without modifications. All units have drain-pan connections on both sides, and pans can be pitched for right-hand or left hand operation with a simple adjustment.

Fan motors and contactors are pre-wired and TXVs are factory-installed on FAX/FAS models.

High-efficiency, precision balanced fans minimize air turbulence, surging, and unbalanced operation, thereby cutting operating expenses.

2-Speed Indoor Fan Motor System

Our 2-Speed Indoor Fan Motor system units will automatically adjust the indoor fan motor speed in sequence with the unit's cooling operation. Per ASHRAE 90.1 2010 standard section 6.4.3.10.b, during the first stage of cooling operation the fan motor (either ECM or controlled by VFD) will adjust to provide two-thirds of the total cfm established for the unit. When a call for the second stage of cooling is required, the fan motor will allow the total cfm (100%) established for the unit. During the heating mode the fan motor will allow total design cfm (100%) operation and during the ventilation mode the fan motor will allow operation to two-thirds of total cfm.

Model number nomenclature

FAX Model Number Nomenclature

MODEL SERIES	F	A	X	0	9	1	H	2	A	A	0	A	U	A
Position Number	1	2	3	4	5	6	7	8	9	10	11	12	13	14
F = R-410A Fan Coil Unit														
A = Air Conditioning (Cooling Only) H = Heat Pump														
	Type													
X = X-Vane Vane Axial Fan (VAF)														
	Efficiency													
072 = 6 Tons (1 circuit) 091 = 7.5 Tons (1 circuit) 120 = 10 Tons (2 circuit)														
	Nominal Tonnage													
H = 208/230-3-60 L = 460-3-60 S = 575-3-60														
	Voltage¹													
2 = Standard Efficiency / Medium Static Motor 3 = Standard Efficiency / High Static Motor														
	Fan Motor Options													
A = Al/Cu														
	Coil Options													
A = Standard DX Coil														
	Type of Coil													
0 = X-Vane Two-Speed Fan														
	Fan Motor Speed Controller													
A = Standard — Unpainted B = Painted Cabinet														
	Painted Cabinet Options													
U = Unit Control Board (UCB) Electromechanical Controls														
	Controls													
A = Standard														
	Packaging													

¹ There are no multi-voltage units with the 2-Speed Vane Axial Fan (VAF), as the motors are dedicated voltage.

Model number nomenclature (cont)

FAS Model Number Nomenclature

MODEL SERIES	F	A	S	1	5	0	H	A	A	A	2	A	U	A
Position Number	1	2	3	4	5	6	7	8	9	10	11	12	13	14
F = R-410A Fan Coil Unit														
A = Air Conditioning (Cooling Only) H = Heat Pump (size 180 only)	Type													
S = Standard Efficiency	Efficiency													
150 = 12.5 Tons (2 circuit) (FAS units only) 180 = 15 Tons (2 circuit)	Nominal Tonnage													
H = 208/230-3-60 L = 460-3-60 S = 575-3-60	Voltage¹													
A = Standard Static Standard Efficiency Motor / Standard Drive B = High (Alternate) Static Standard or High Efficiency Motor / High Drive ²	Fan Motor Options													
A = Al/Cu	Indoor Coil													
A = Standard Coil (FAS, DX (Direct Expansion) coil; FHS, heat pump coil)	Coil Type													
2 = Two Speed Fan Controller (VFD)	Indoor Fan Speed Controller													
A = None (unpainted) B = Painted cabinet	Painted Cabinet Options													
U = Electromechanical Unit Control Board	Controls													
A = Standard	Packaging													

¹ There are no multi-voltage units with the optional 2-speed indoor fan motor / VFD controller. VFD controllers are dedicated voltage devices for 208/230v, 460v, and 575v.

² For FAS, standard efficiency on size 150, voltages 208-230v and 460v. High efficiency on size 180, as well as size 150, 575v. For FHS, high efficiency only.

MODEL SERIES	F	A	S	2	4	0	H	A	A	A	2	A	U	A
Position Number	1	2	3	4	5	6	7	8	9	10	11	12	13	14
F = R-410A Fan Coil Unit														
A = Air Conditioning (Cooling Only) H = Heat Pump (size 240 only)	Type													
S = Standard Efficiency	Efficiency													
240 = 20 Tons (2 circuit) 300 = 25 Tons (2 circuit; FAS units only) 336 = 30 Tons (2 circuit; FAS units only)	Nominal Tonnage													
H = 208/230-3-60 L = 460-3-60 S = 575-3-60	Voltage¹													
A = Standard Static High Efficiency Motor / Standard Static Drive B = High Static Standard or High Efficiency Motor / High Static Drive ²	Fan Motor Options													
A = Al/Cu	Indoor Coil													
A = Standard Coil (DX for FAS; Heat Pump for FHS)	Coil Type													
2 = Two-Speed Indoor Fan Motor Controller (VFD)	Indoor Fan Speed Controller													
A = Standard, Unpainted B = Painted Cabinet	Painted Cabinet Options													
U = Electromechanical Unit Control Board	Controls													
A = Standard	Packaging													

¹ There are no multi-voltage units with the 2-speed indoor fan motor / VFD controller. VFD controllers are dedicated voltage.

² For FAS, size 336 is designated standard motor, high static drive. Not offered on 575v. For FHS, size 240 is offered with standard motor, high static drive.

Model number nomenclature (cont)

FAX — 2-Speed Motors

POSITION 8	MOTOR DESCRIPTION	VOLTAGE	UNIT SIZE		
			072	091	120
2	Standard/Medium Static (X-Vane)	All	X	X	X
3	High Static (X-Vane)	All	X	X	X

FAS — 2-Speed Motors

POSITION 8	MOTOR DESCRIPTION	VOLTAGE	UNIT SIZE				
			150	180	240	300	336 ^a
A	Standard Efficiency Motor / Standard Static	All	X	X	—	—	—
	High Efficiency Motor / Standard Static	All	—	—	X	X	X
B	Standard Efficiency Motor / High Static	208/23-3-60 460-3-60	X	—	—	—	—
	High Efficiency Motor / High Static	208/230-3-60 460-3-60	—	X	X	X	X
		575-3-60	X	X	X	X	X

NOTE(S):

a. Size 336 is designated standard motor and high static drive.

Physical data

FAX/FAS 6-30 Ton Direct Expansion with R-410A Refrigerant Units

UNIT	FAX072	FAX091	FAX120	FAS150	FAS180	FAS240	FAS300	FAS336
NOMINAL CAPACITY (Tons)	6	7-1/2	10	12-1/2	15	20	25	30
OPERATING WEIGHT (lb)								
Base Unit with TXV (4 Row)	399	404	425	695	713	730	1050	1062
Plenum	175	175	175	225	225	225	325	325
Economizer	185	185	185	340	340	340	340	340
Hot Water Coil ^a	195	195	195	285	285	285	345	345
Steam Coil ^a	215	215	215	340	340	340	405	405
FANS								
Qty...Diam. (in.)	1...23	1...23	1...23	2...15	2...15	2...15	2...18	2...18
Nominal Airflow (cfm)	2,400	3,000	4,000	5,000	6,000	8,000	10,000	12,000
Airflow Range (cfm)	1,800-3,000	2,250-3,750	3,000-5,000	3,750-6,250	4,500-7,500	6,000-10,000	7,500-12,500	9,000-15,000
Nominal Motor hp (Standard Motor) ^{b,c}								
208/230-3-60 and 460-3-60	2.4	2.4	2.4	2.9	3.7	5.0	7.5	10.0
575-3-60	2.4	2.4	2.4	3.0	3.0	5.0	7.5	10.0
Motor Speed (rpm)								
208/230-3-60 and 460-3-60	2000	2000	2000	1725	1725	1760	1760	1755
575-3-60	2000	2000	2000	1725	1725	1745	1755	1755
REFRIGERANT^d	R-410A	R-410A	R-410A	R-410A	R-410A	R-410A	R-410A	R-410A
Shipping Charge (lb)	Nitrogen Purge	Nitrogen Purge	Nitrogen Purge	Nitrogen Purge	Nitrogen Purge	Nitrogen Purge	Nitrogen Purge	Nitrogen Purge
Metering Device	TXV	TXV	TXV	TXV	TXV	TXV	TXV	TXV
Operating Charge (lb) (approx per circuit)	3.0	3.0	1.5/1.5	2.0/2.0	2.5/2.5	3.5/3.5	4.5/4.5	5.0/5.0
DIRECT-EXPANSION COIL	Enhanced Copper Tubes, Aluminum Sine-Wave Fins							
Max Working Pressure (psig)	650	650	650	650	650	650	650	650
Material	Al / Cu	Al / Cu	Al / Cu	Al / Cu	Al / Cu	Al / Cu	Al / Cu	Al / Cu
Coil Type	RTPF	RTPF	RTPF	RTPF	RTPF	RTPF	RTPF	RTPF
Face Area (sq ft)	6.67	8.33	10.01	13.25	17.67	19.88	24.86	29.83
No. of Splits	1	1	2	2	2	2	2	2
Split Type...Percentage	—	—	Face...50/50	Face...50/50	Face...50/50	Face...50/50	Face...50/50	Face...50/50
No. of Circuits per Split	12	15	9	12	16	18	20	24
Rows...Fins/in.	4...15	4...15	4...15	4...15	4...15	4...15	4...15	4...15
STEAM COIL^a								
Max Working Press. (psig at 260°F)	20	20	20	20	20	20	20	20
Total Face Area (sq ft)	6.67	6.67	6.67	13.33	13.33	13.33	15.0	15.0
Rows...Fins/in.	1...9	1...9	1...9	1...10	1...10	1...10	1...10	1...10
HOT WATER COIL^a								
Max Working Pressure (psig)	150	150	150	150	150	150	150	150
Total Face Area (sq ft)	6.67	6.67	6.67	13.33	13.33	13.33	15.0	15.0
Rows...Fins/in.	2...8.5	2...8.5	2...8.5	2...8.5	2...8.5	2...8.5	2...12.5	2...12.5
Water Volume								
(gal)	8.3	8.3	8.3	13.9	13.9	13.9	14.3	14.3
(ft ³)	1.1	1.1	1.1	1.85	1.85	1.85	1.90	1.90
PIPING CONNECTIONS								
Quantity...Size (in.)								
DX Coil — Suction (ODF)	1...1-1/8	1...1-1/8	2...1-1/8	2...1-1/8	2...1-1/8	2...1-1/8	2...1-3/8	2...1-3/8
DX Coil — Liquid Refrig (ODF)	1...5/8	1...5/8	2...5/8	2...5/8	2...5/8	2...5/8	2...5/8	2...5/8
Steam Coil, In (MPT)	1...2-1/2	1...2-1/2	1...2-1/2	1...2-1/2	1...2-1/2	1...2-1/2	1...2-1/2	1...2-1/2
Steam Coil, Out (MPT)	1...1-1/2	1...1-1/2	1...1-1/2	1...1-1/2	1...1-1/2	1...1-1/2	1...1-1/2	1...1-1/2
Hot Water Coil, In (MPT)	1...1-1/2	1...1-1/2	1...1-1/2	1...2	1...2	1...2	1...2	1...2
Hot Water Coil, Out (MPT)	1...1-1/2	1...1-1/2	1...1-1/2	1...2	1...2	1...2	1...2	1...2
Condensate (PVC)	1...5/8 ODM / 1-1/4 IDF	1...5/8 ODM / 1-1/4 IDF	1...5/8 ODM / 1-1/4 IDF	1...5/8 ODM / 1-1/4 IDF	1...5/8 ODM / 1-1/4 IDF	1...5/8 ODM / 1-1/4 IDF	1...5/8 ODM / 1-1/4 IDF	1...5/8 ODM / 1-1/4 IDF
FILTERS	Throwaway — Factory-Supplied	Throwaway — Factory-Supplied	Throwaway — Factory-Supplied	Throwaway — Factory-Supplied	Throwaway — Factory-Supplied	Throwaway — Factory-Supplied	Throwaway — Factory-Supplied	Throwaway — Factory-Supplied
Quantity...Size (in.)	4...16 x 24 x 2	4...16 x 24 x 2	4...16 x 24 x 2	4...16 x 20 x 2 4...16 x 24 x 2	4...16 x 20 x 2 4...16 x 24 x 2	4...16 x 20 x 2 4...16 x 24 x 2	4...20 x 24 x 2 4...20 x 25 x 2	4...20 x 24 x 2 4...20 x 25 x 2
Access Location	Right or Left Side	Right or Left Side	Right or Left Side	Right or Left Side	Right or Left Side	Right or Left Side	Right or Left Side	Right or Left Side

NOTE(S):

- a. Field-installed accessory only.
- b. FAX units are medium static option.
- c. Refer to Alternate Fan Motor Data table for alternate motor data (page 7).
- d. Units are shipped without refrigerant charge.

Physical data (cont)

FAX Fan Motor Data Standard Motor — Direct Drive Two Speed Motor

UNIT	FAX072	FAX091	FAX120
230-3-60, 460-3-60, and 575-3-60			
Speed (rpm)	2000	2000	2000
Hp	2.4	2.4	2.4

Motor Efficiency FAX — Direct Drive Two Speed Motor

MOTOR hp	MOTOR EFFICIENCY	
2.4	85.0%	
3.0	85.0%	

WEIGHTS	MEDIUM	HIGH
Motor hp	2.4	3.0
Motor Weight (lb)	23.8	53.7
Assembly Weight (lb)	56.4	85.6

FAS Fan Motor Data — Two Speed Standard Motor

UNIT	FAS150	FAS180	FAS240	FAS300	FAS336
208/230-3-60 and 460-3-60					
Speed (rpm)	1735	1750	1755	1760	1755
Hp	2.9	3.7	5.0	7.5	10.0
Frame (NEMA)	56HY	56HY	184T	S213T	S215T
Shaft Dia (in.)	7/8	7/8	1-1/8	1-3/8	1-3/8
575-3-60					
Speed (rpm)	1710	1710	1755	1750	1755
Hp	3.7	3.7	5.0	7.5	10.0
Frame (NEMA)	56HY	56HY	184T	S213T	S215T
Shaft Dia (in.)	7/8	7/8	1-1/8	1-3/8	1-3/8

LEGEND

NEMA — National Electrical Manufacturers Association (U.S.A.)

FAS Fan Motor Data — Two Speed Alternate Motor

UNIT	FAS150	FAS180	FAS240	FAS300	FAS336
208/230-3-60 and 460-3-60					
Speed (rpm)	1750	1755	1760	1755	1755
Hp	3.7	5.0	7.5	10.0	10.0
Frame (NEMA)	56HY	184T	S213T	S215T	S215T
Shaft Dia (in.)	7/8	1-1/8	1-3/8	1-3/8	1-3/8
575-3-60					
Speed (rpm)	1755	1755	1750	1755	1755
Hp	5.0	5.0	7.5	10.0	10.0
Frame (NEMA)	184T	184T	S213T	S213T	S215T
Shaft Dia (in.)	1-1/8	1-1/8	1-3/8	1-3/8	1-3/8

LEGEND

NEMA — National Electrical Manufacturers Association (U.S.A.)

Motor Efficiency FAS — Two Speed Motor

MOTOR hp	EPACT MINIMUM	MOTOR EFFICIENCY
2.9	—	86.5%
3.7	—	83.6%
5.0	89.5%	89.5%
7.5	91.7%	91.7%
10.0	91.7%	91.7%

LEGEND

EPACT — Energy Policy and Conservation Act of 1992 (U.S.A.)

Physical data (cont)

Standard Static Data, 60 Hz

UNIT	FAS150	FAS180	FAS240	FAS300	FAS336
MOTOR DRIVE					
Motor Pulley Pitch Diameter (in.)	2.8-3.8	2.8-3.8	3.7-4.7	4.3-5.3	4.3-5.3
Pulley Factory Setting Full Turns Open	2.5	2.5	3.0	3.0	3.0
FAN DRIVE					
Pulley Pitch Dia (in.)	9.0	9.0	9.4	11.0	11.0
Pulley Bore (in.)	1-7/16	1-7/16	1-7/16	1-15/16	1-15/16
Belt No. — Section	1—A	1—A	1—B	2—B ^a	2—B ^a
Belt Pitch (in.)	42.3	42.3	41.8	(2) 42.8 (2) 43.8	(2) 42.8 (2) 43.8
FAN SPEEDS (rpm)					
Factory Settings	632	632	771	752	752
Range	537-728	537-728	679-863	682-841	674-831
Max Allowable Speed (rpm)	1200	1200	1200	1100	1100
Change per 1/2 turn of Movable Motor Pulley Flange	19.1	19.1	15.3	13.1	13.1
MAX FULL TURNS FROM CLOSED POSITION					
	5	5	6	6	6
SHAFTS CENTER DISTANCE (in.)					
	10.44-12.32	10.44-12.32	9.12-10.99	6.67-9.43	6.67-9.43

NOTE(S):

a. Four belts shipped with unit. Use correct set of 2 belts sized according to the pulley setting.

High Static Data, 60 Hz

UNIT	FAS150	FAS180	FAS240	FAS300	FAS336
MOTOR DRIVE					
Motor Pulley Pitch Diameter (in.)	3.7-4.7	4.3-5.3	4.3-5.3	4.3-5.3	4.3-5.3
Pulley Factory Setting Full Turns Open	3.0	3.0	3.0	3.0	3.0
FAN DRIVE					
Pulley Pitch Dia (in.)	7.4	7.9	7.4	8.6	8.6
Pulley Bore (in.)	1-7/16	1-7/16	1-7/16	1-15/16	1-15/16
Belt No. — Section	1—B	1—B	2—B	2—B	2—B
Belt Pitch (in.)	39.8	39.8	36.8	37.8	37.8
FAN SPEEDS (rpm)					
Factory Setting	979	1060	1118	1024	1024
Range	873-1096	950-1171	1014-1200 ^a	873-1075	873-1075
Max Allowable Speed (rpm)	1200	1200	1200	1100	1100
Change per 1/2 Turn of Movable Motor Pulley Flange	19.4	18.4	19.4	16.7	16.7
MAX FULL TURNS FROM CLOSED POSITION					
	6	6	6	6	6
SHAFTS CENTER DISTANCE (in.)					
	10.44-12.32 ^b	9.16-10.99	8.16-10.02	6.67-9.43	6.67-9.43

NOTE(S):

a. It is possible to adjust drive so that fan speed exceeds maximum allowable. DO NOT exceed 1200 rpm.

b. 575-v unit has a center distance of 9.16-10.99.

Options and accessories

ITEM	FACTORY-INSTALLED OPTION	FIELD-INSTALLED ACCESSORY
Alternate Drive (FAS only)	X	
Alternate Fan Motor (FAS only)	X	
CO ₂ Sensors		X
Condensate Drain Trap		X
Discharge Duct Adapter (FAX only)		X
Discharge Plenum		X
EconoMi\$er IV Standard Leak		X
EconoMi\$er X Ultra Low Leak — FDD		X
Electric Heater		X
Hot Water Heating Coils (2 row)		X
Optional VFD Display Kit (FAS only)		X
Overhead Suspension Package		X
Pre-Painted Units	X	
Return Air Grille		X
Steam Heating Coil (1 row)		X

Factory-installed options

Alternate fan motors and drives (FAS only)

Alternate fan motors and drives are available to provide the widest possible range of performance.

Pre-painted steel units

Pre-painted units are available from the factory for applications that require painted units. Units are painted with American Sterling Gray color.

Field-installed accessories

Optional VFD display Kit (FAS only)

There is an optional VFD display kit offered (as an accessory) for FAS units to allow the user to troubleshoot any VFD faults in the field after start-up.

NOTE: Do not use the VFD display kit to adjust the frequency and voltage in the VFD to required performance requirements. This could lead to decreased life of the motor and VFD.

Two-row hot water coils

Two-row hot water coils have copper tubes mechanically bonded to aluminum plate fins and non-ferrous headers.

One-row steam coil

One-row steam coils have copper tubes and aluminum fins.

The Inner Distributing Tube (IDT) design provides uniform temperatures across the coil face. The steam coil has a broad operating pressure range; up to 20 psi (138 kPag) at 260°F (126°C). The IDT steam coils are especially suited to applications where sub-freezing air enters the unit.

Electric heater

Electric heaters are available as factory-supplied, field-installed accessories for nominal 240v, 480v, and 575v, 3-phase, 60 Hz units. Electric heaters are ETL (U.S.A.) and ETL, Canada, agency-approved. They have single-point power wiring. The heater assembly includes contactors with 24-v coils, power wiring, 24-v control wiring

terminal blocks, and a hinged access panel. Electric heaters should not be used with an air discharge plenum.

Economizers — temperature dry bulb controlled

Ultra Low Leak — EconoMi\$er X

This economizer accessory comes with solid-state W7220 controller, gear-driven, modulating damper, and spring return actuator. It is supply/outdoor air sensors, and CO₂ sensor compatible, for use in electro-mechanical controls only. It also includes return and outside air damper leakage that meets California Title 24 section 140.4 requirements. Controller meets California Title 24 Section 120.2 Fault Detection and Diagnostic (FDD) requirements. Also meets AMCA Class 1A economizer damper test standards and labeling.

Standard — EconoMi\$er IV

The standard economizer accessory comes with gear driven damper blades and a W7212 controller (use p/n 1176668 sensor for enthalpy control).

Discharge plenum

Discharge plenum directs the air discharge directly into the occupied space; integral horizontal and vertical louvers enable redirection of airflow. This accessory is available unpainted or painted. Field assembly is required (only applicable for vertical application).

Return-air grille

The return-air grille provides a protective barrier over the return-air opening and gives a finished appearance to units installed in the occupied space. This accessory is available unpainted or painted.

Overhead suspension package

The overhead suspension package includes necessary brackets to support units in horizontal ceiling installations.

CO₂ sensors

CO₂ sensors can be used in conjunction with the economizer accessory to help meet indoor air quality requirements. The sensor signals the economizer to open when the CO₂ level in the space exceeds the set point. A field-installed programmable thermostat can be used to override the sensor if the outside-air temperature is too high or too low.

Condensate drain trap

The condensate drain trap includes an overflow shutoff switch that can be wired to turn off the unit if the trap becomes plugged. Kit also includes a wire harness that can be connected to an alarm if desired. The transparent trap is designed for easy service and maintenance.

Discharge duct adapter

This accessory is required for replacements using FAX units with or without electric heat. It is not required for new installations or when using steam coil, hot water coil, or discharge plenum accessories.

Options and accessories (cont)

**FAX/FAS with Discharge Plenum
Return-Air Grille and Subbase**

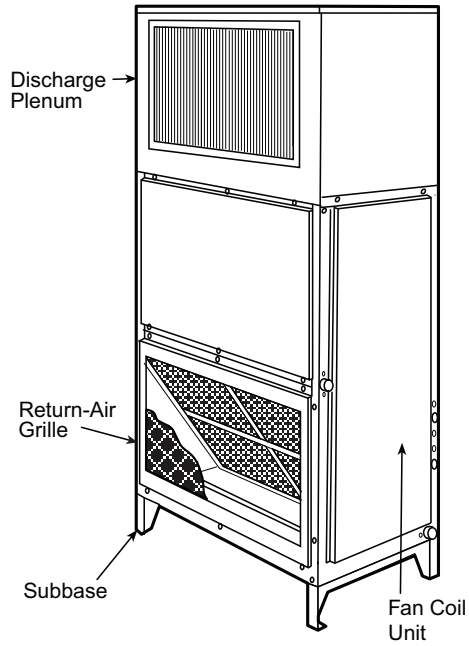

FAX/FAS with Hot Water or Steam Coil

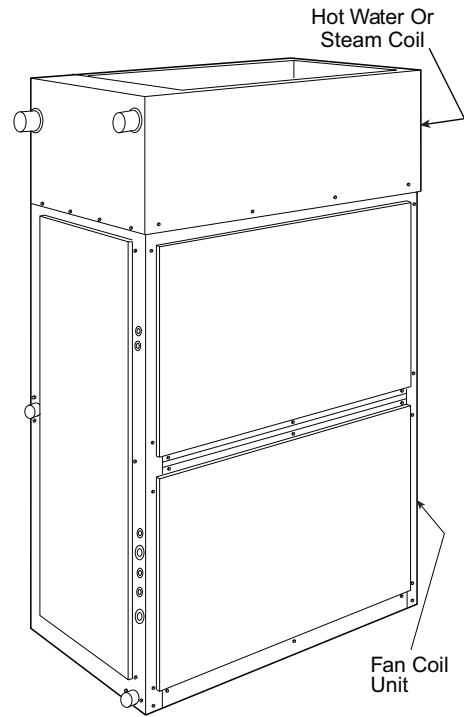

FAX/FAS with Economizer

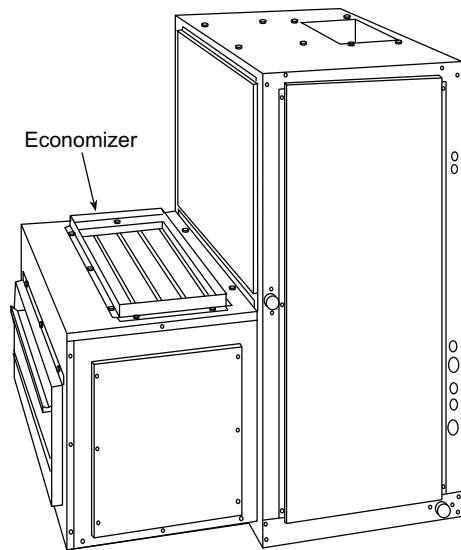

FAX/FAS with Condensate Trap

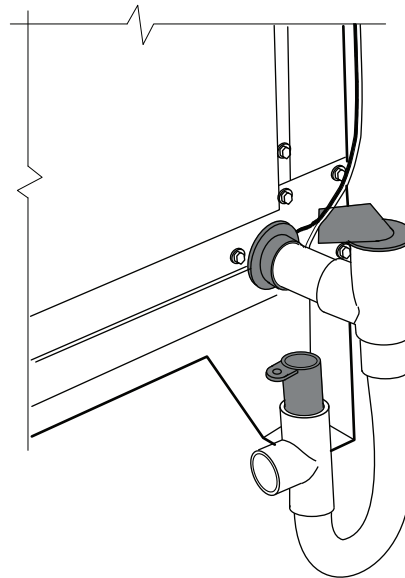

FAS150-240

UNIT	UNIT WEIGHT (W/TXV)
FAS150	695 lbs [316 kg]
FAS180	713 lbs [323 kg]
FAS240	730 lbs [332 kg]
FHS180	713 lbs [323 kg]
FHS240	720 lbs [327 kg]



THIS DOCUMENT IS THE PROPERTY OF CARRIER CORPORATION AND IS DELIVERED UPON THE EXPRESS CONDITION THAT THE CONTENTS WILL NOT BE DISCLOSED OR USED WITHOUT WRITTEN CONSENT.

SUBMISSION OF THESE DRAWINGS OR DOCUMENTS DOES NOT CONSTITUTE PART PERFORMANCE OR ACCEPTANCE OF CONTRACT.

- NOTES:
1. DIMENSIONS IN [] ARE IN MILLIMETERS.
 2. DIRECTIONS OF AIRFLOW.
 3. RECOMMENDED CLEARANCE:
 REAR: 2 ft 6 in. [762 mm]
 FRONT: 2 ft 6 in. [762 mm]
 RIGHT SIDE: 2 ft 6 in. [762 mm]
 LEFT SIDE: 2 ft 6 in. [762 mm]
 LOCAL CODES OR JURISDICTION MAY PREVAIL.
 4. LIQUID PIPING NOT SUPPLIED BY CARRIER.
 5. DUCT FLANGE IS FACTORY SUPPLIED AND FIELD INSTALLED.

ACCESSORY	SEE DRAWING
DISCHARGE PLENUM	40RMS00997
ECONOMIZER	40RMS01000
STEAM COIL	40RMS01000
HOT WATER COIL	40RMS01000
RETURN AIR GRILLE	40RMS00997
OVERHEAD SUSPENSION	40RMS00997
SUBBASE	40RMS00997
ELECTRIC HEAT <input checked="" type="checkbox"/>	40RMS01002

UNRELEASED DATA

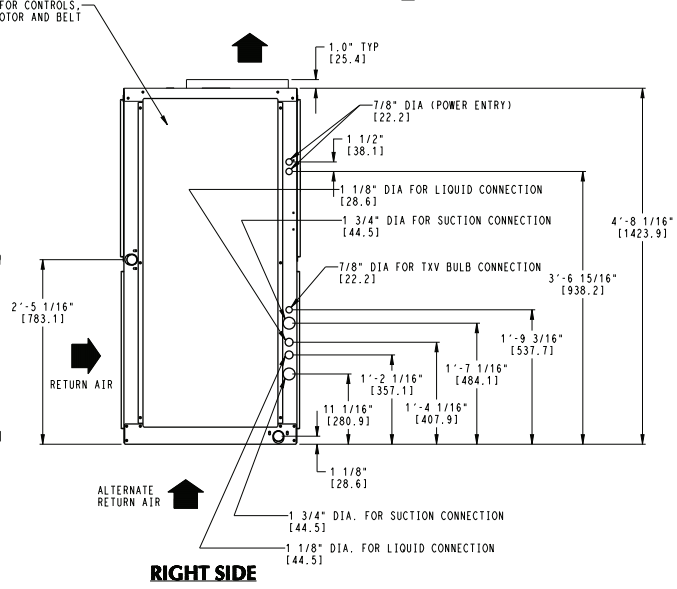
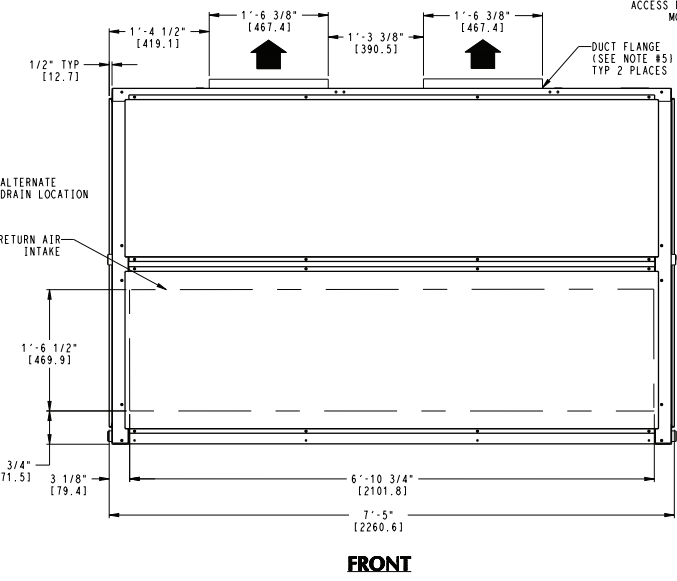
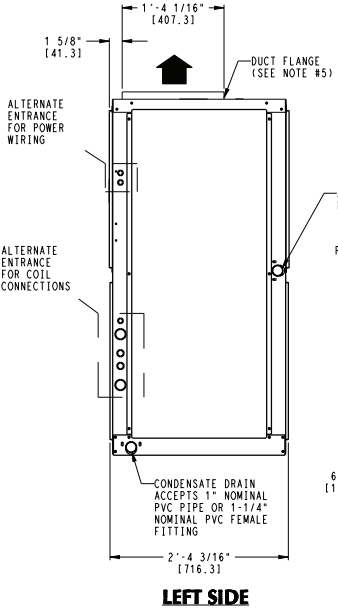
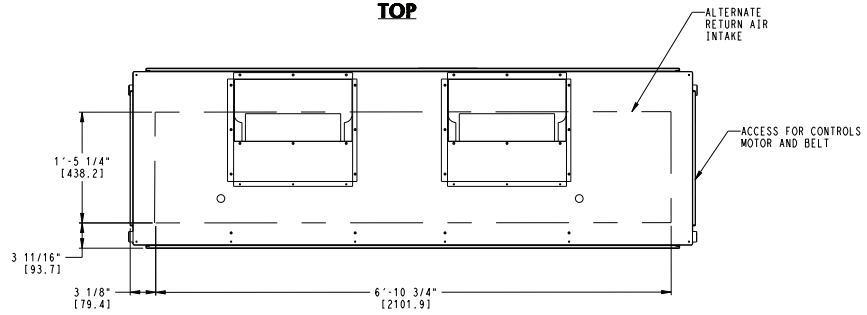

ITC CLASSIFICATION	SHEET	DATE	SUPERCEDES	FAN COIL UNITS	40RU500100	REV
U.S. ECCN:NSR	1 OF 2	07/14/21	03/16/18	FAS / FHS - 150 / 180 / 240		E

FAS300/336



THIS DOCUMENT IS THE PROPERTY OF CARRIER CORPORATION AND IS DELIVERED UPON THE EXPRESS CONDITION THAT THE CONTENTS WILL NOT BE DISCLOSED OR USED WITHOUT WRITTEN CONSENT.

SUBMISSION OF THESE DRAWINGS OR DOCUMENTS DOES NOT CONSTITUTE PART PERFORMANCE OR ACCEPTANCE OF CONTRACT.

UNIT	UNIT WEIGHT (W/TXV)
FAS300	1050 lbs [477 kg]
FAS336	1062 lbs [482 kg]

- NOTES:
1. DIMENSIONS IN [] ARE IN MILLIMETERS.
 2. DIRECTIONS OF AIRFLOW.
 3. RECOMMENDED CLEARANCE:
 REAR: 2 ft 6 in. [762 mm]
 FRONT: 2 ft 6 in. [762 mm]
 RIGHT SIDE: 2 ft 6 in. [762 mm]
 LEFT SIDE: 2 ft 6 in. [762 mm]
 LOCAL CODES OR JURISDICTION MAY PREVAIL.
 4. LIQUID PIPING NOT SUPPLIED BY CARRIER.
 5. DUCT FLANGE IS FACTORY SUPPLIED AND FIELD INSTALLED.

ACCESSORY	SEE DRAWING
DISCHARGE PLENUM	40RMS00998
ECONOMIZER	40RMS01001
STEAM COIL	40RMS01001
HOT WATER COIL	40RMS01001
RETURN AIR GRILLE	40RMS00998
OVERHEAD SUSPENSION	40RMS00998
SUBBASE	40RMS00998
ELECTRIC HEAT <input checked="" type="checkbox"/>	40RMS01002

UNRELEASED DATA

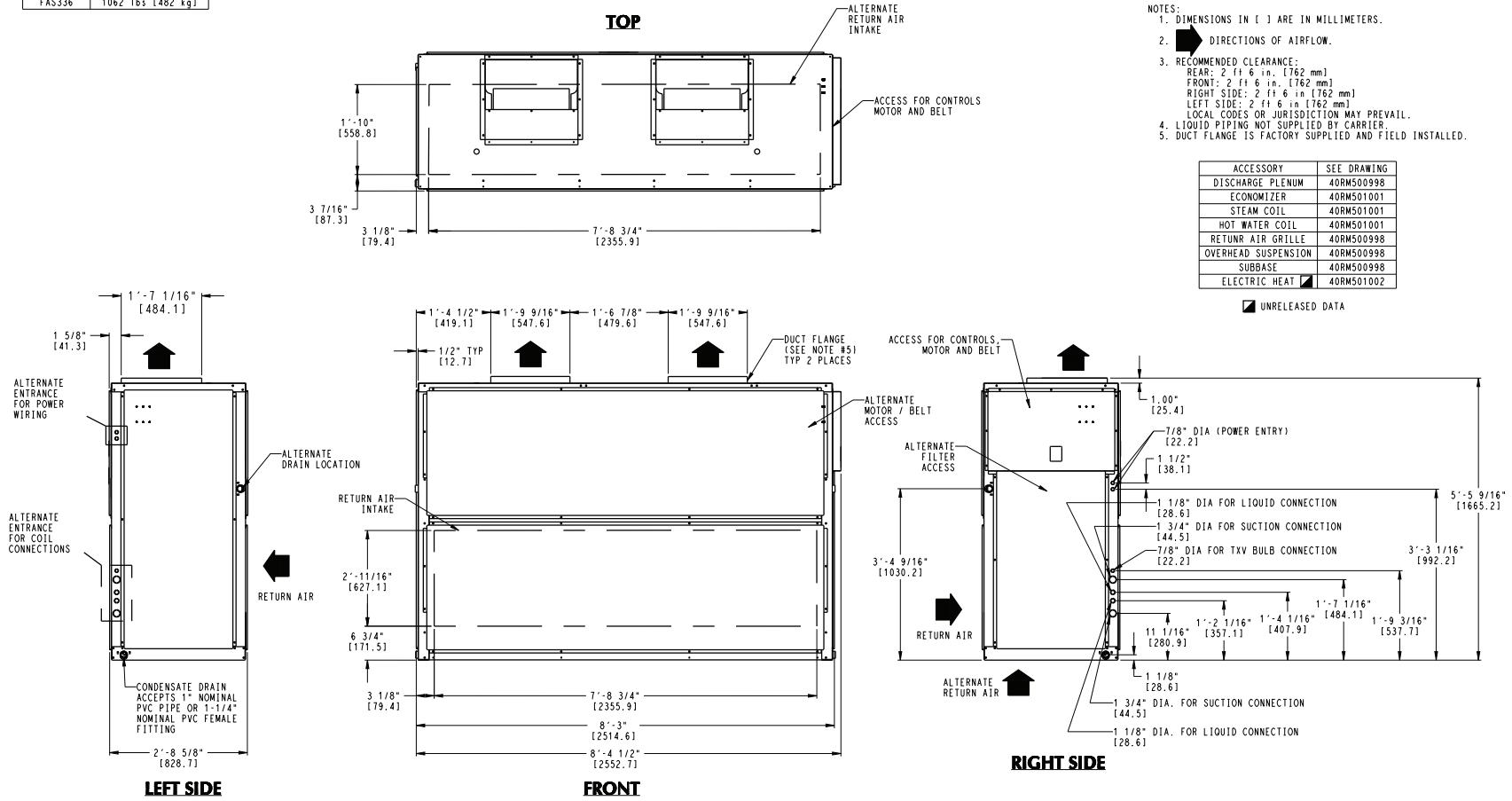

ITC CLASSIFICATION	SHEET	DATE	SUPERCEDES	FAN COIL UNITS	40RU500101	REV
U.S. ECCN:NSR	1 OF 2	07/14/21	03/16/18	FAS - 300 / 336		E

Base unit dimensions (cont)

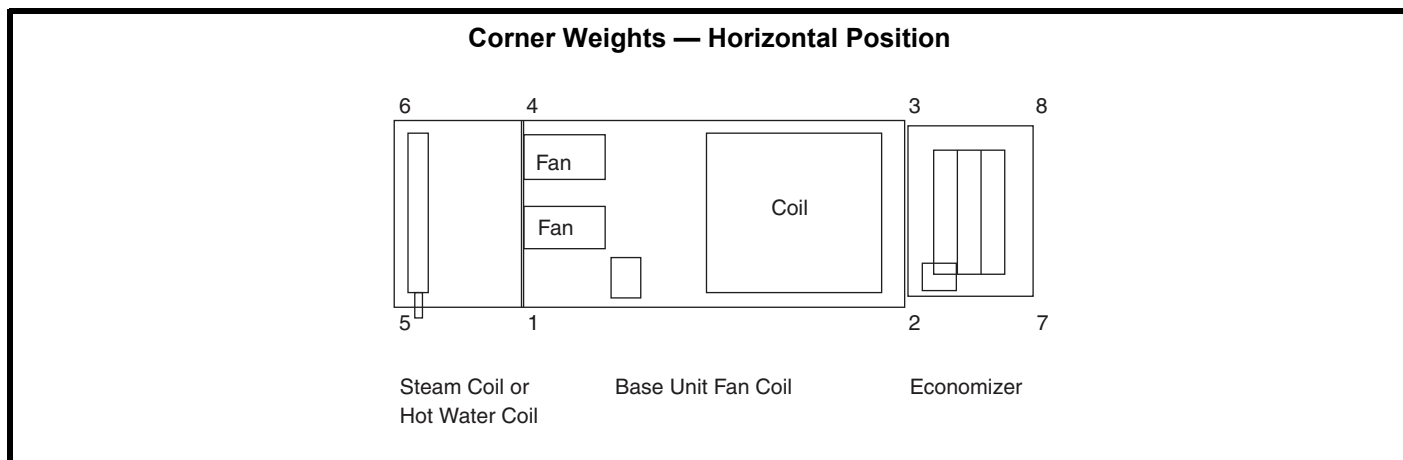

FAX/FAS Horizontal Position

UNIT SIZE	UNIT OR ACCESSORY NAME		UNIT OR ACCESSORY WEIGHT (lb)	CORNER NUMBER (Weight in lb)							
				1	2	3	4	5	6	7	8
FAX072	Fan Coil Base Unit		399	109.3	106.1	90.6	93.4	—	—	—	—
FAX091	Fan Coil Base Unit		404	110.7	107.5	91.7	94.5	—	—	—	—
FAX120	Fan Coil Base Unit		425	116.4	113.0	96.5	99.4	—	—	—	—
FAX 072, 091, 120	Steam Coil	Add	215	40.2	—	—	40.6	66.5	67.5	—	—
	Hot Water Coil	Add	195	35.9	—	—	36.7	60.4	62.0	—	—
	Economizer	Add	185	—	36.8	35.7	—	—	—	56.8	55.1
	Eco + Steam Coil	Add	400	38.8	38.6	37.4	39.2	64.2	65.2	59.5	57.7
	Eco + Hw Coil	Add	380	36.9	35.8	34.6	37.7	62.1	63.8	55.1	53.4
FAS150	Fan Coil Base Unit		695	224.0	177.7	129.8	163.7	—	—	—	—
FAS180	Fan Coil Base Unit		713	229.8	182.3	133.2	167.9	—	—	—	—
FAS240	Fan Coil Base Unit		730	235.6	186.4	136.5	171.5	—	—	—	—
FAS 150-240	Steam Coil	Add	340	61.4	—	—	62.0	107.8	108.8	—	—
	Hot Water Coil	Add	285	51.7	—	—	51.3	91.5	90.6	—	102.0
	Economizer	Add	340	—	66.9	62.0	—	—	—	109.8	97.1
	Eco + Steam Coil	Add	680	64.4	63.7	59.0	65.0	113.0	114.1	104.5	87.8
	Eco + Hw Coil	Add	625	60.0	57.6	53.4	59.5	106.2	105.1	94.6	—
FAS300	Fan Coil Base Unit		1050	338.4	268.5	196.1	247.2	—	—	—	—
FAS336	Fan Coil Base Unit		1062	342.4	271.6	198.3	249.7	—	—	—	—
FAS 300, 336	Steam Coil	Add	405	73.2	—	—	73.8	128.4	129.6	—	—
	Hot Water Coil	Add	345	62.6	—	—	62.1	110.7	109.6	—	—
	Economizer	Add	450	—	88.5	82.0	—	—	—	145.3	134.2
	Eco + Steam Coil	Add	855	80.6	80.1	74.1	81.6	142.0	143.4	131.3	122
	Eco + Hw Coil	Add	795	76.8	73.7	68.2	75.7	135.0	133.6	120.3	111.7

LEGEND

ECO — Economizer
HW — Hot Water

Base unit dimensions (cont)

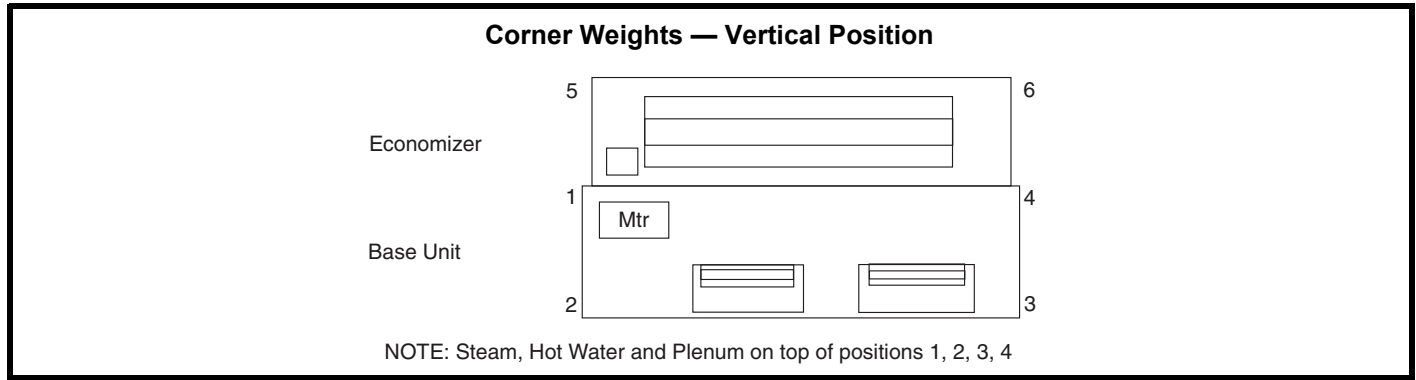

FAX/FAS Vertical Position

UNIT SIZE	UNIT OR ACCESSORY NAME		UNIT OR ACCESSORY WEIGHT (lb)	CORNER NUMBER (Weight in lb)					
				1	2	3	4	5	6
FAX072	Fan Coil Base Unit		399	100.5	114.9	98.0	85.8	—	—
FAX091	Fan Coil Base Unit		404	101.7	116.3	99.1	86.9	—	—
FAX120	Fan Coil Base Unit		425	107.6	122.3	108.0	87.1	—	—
FAX 072-120	Steam Coil	Add	215	54.1	54.1	53.4	53.4	—	—
	Hot Water Coil	Add	195	49.4	49.4	48.1	48.1	—	—
	Plenum	Add	175	50.8	36.7	36.7	50.8	—	—
	Economizer	Add	195	38.9	—	—	37.1	59.9	58.3
	Eco + Steam Coil	Add	410	93.0	53.4	52.6	91.1	61.0	59.1
	Eco + Hw Coil	Add	390	88.9	52.3	50.9	86.5	56.7	54.9
FAS150	Fan Coil Base Unit		695	191.2	210.5	153.8	139.5	—	—
FAS180	Fan Coil Base Unit		713	196.2	216.0	157.8	143.1	—	—
FAS 150, 180	Steam Coil	Add	340	85.4	85.4	84.6	84.6	—	—
	Hot Water Coil	Add	285	70.9	70.9	71.6	71.6	—	—
	Plenum	Add	225	72.5	40.0	40.0	72.5	—	—
	Economizer	Add	340	66.5	—	—	62.0	109.5	102.0
	Eco + Steam Coil	Add	680	153.0	89.1	88.7	147.7	104.5	97.0
	Eco + Hw Coil	Add	625	139.9	82.5	83.3	136.7	94.7	87.9

LEGEND

ECO — Economizer
HW — Hot Water

Accessory dimensions

Overhead Suspension Accessory

6-10 Ton Units (Front)

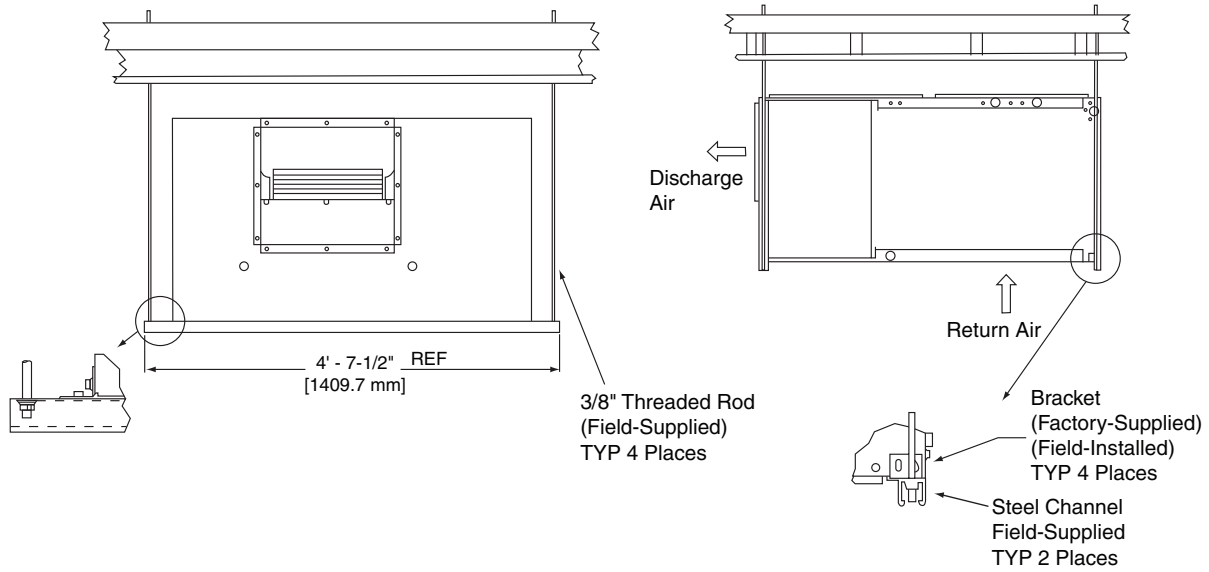

12.5-20 Ton Units (Front)

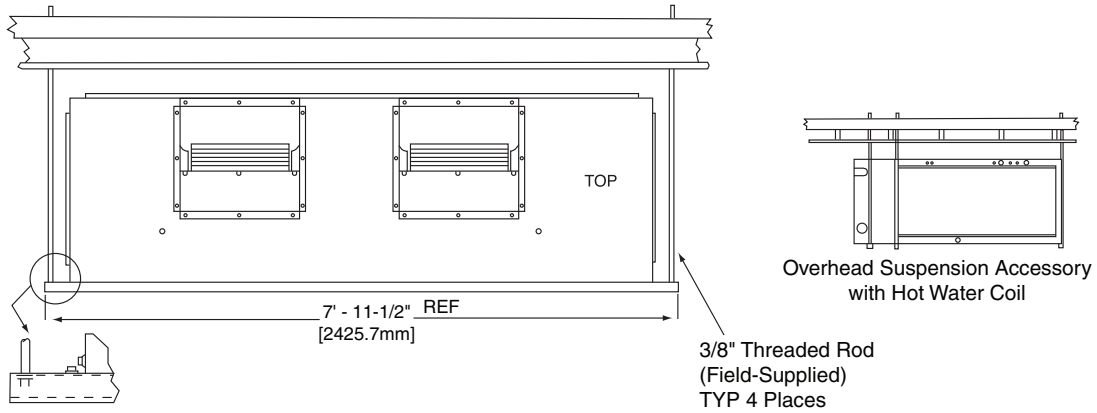

25-30 Ton Units (Front)

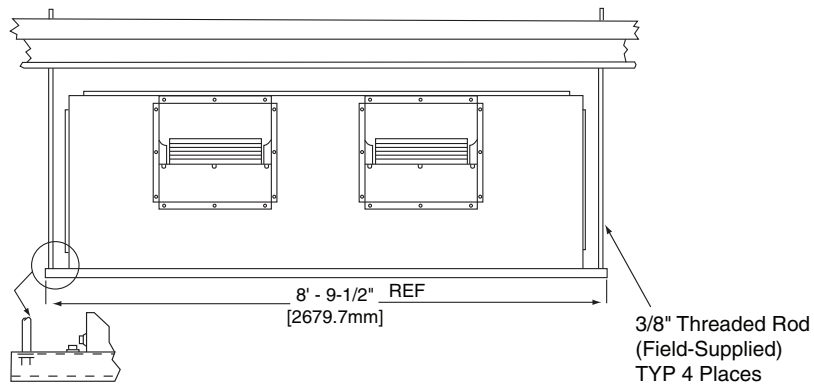

Accessory dimensions (cont)

Plenum, Return-Air Grille, and Subbase Accessories — FAX072-120, FAS150-240

6-10 Ton Units

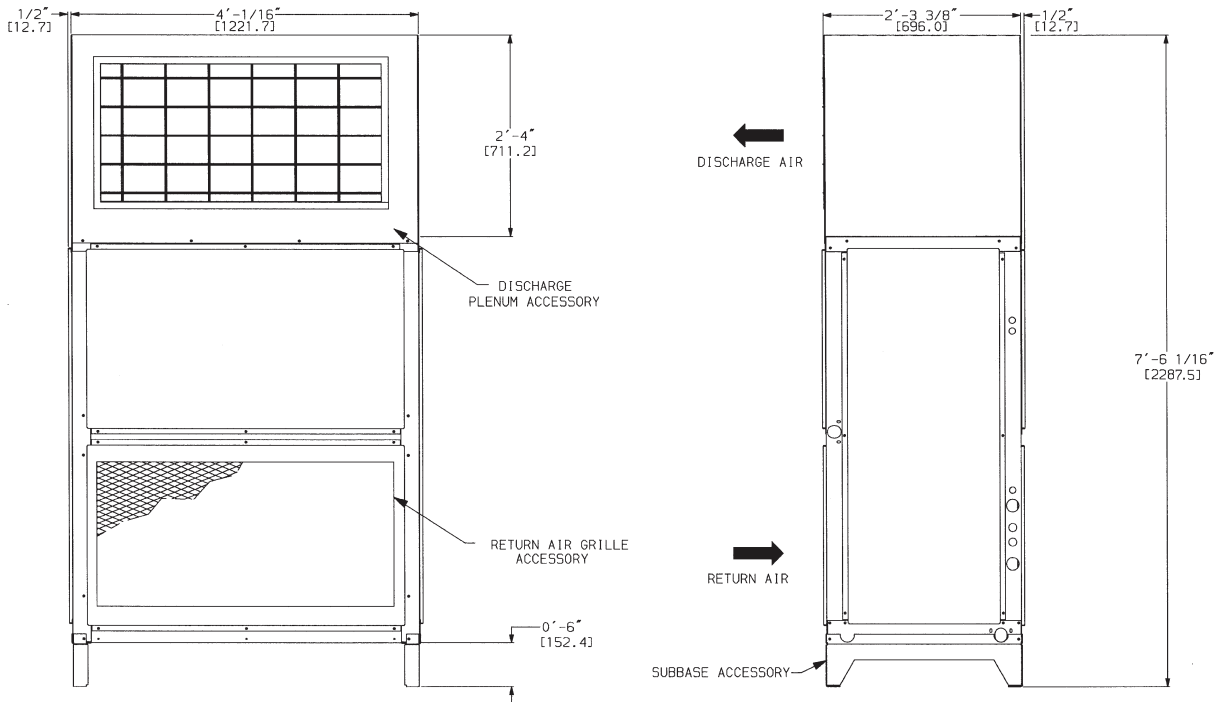

12.5-20 Ton Units

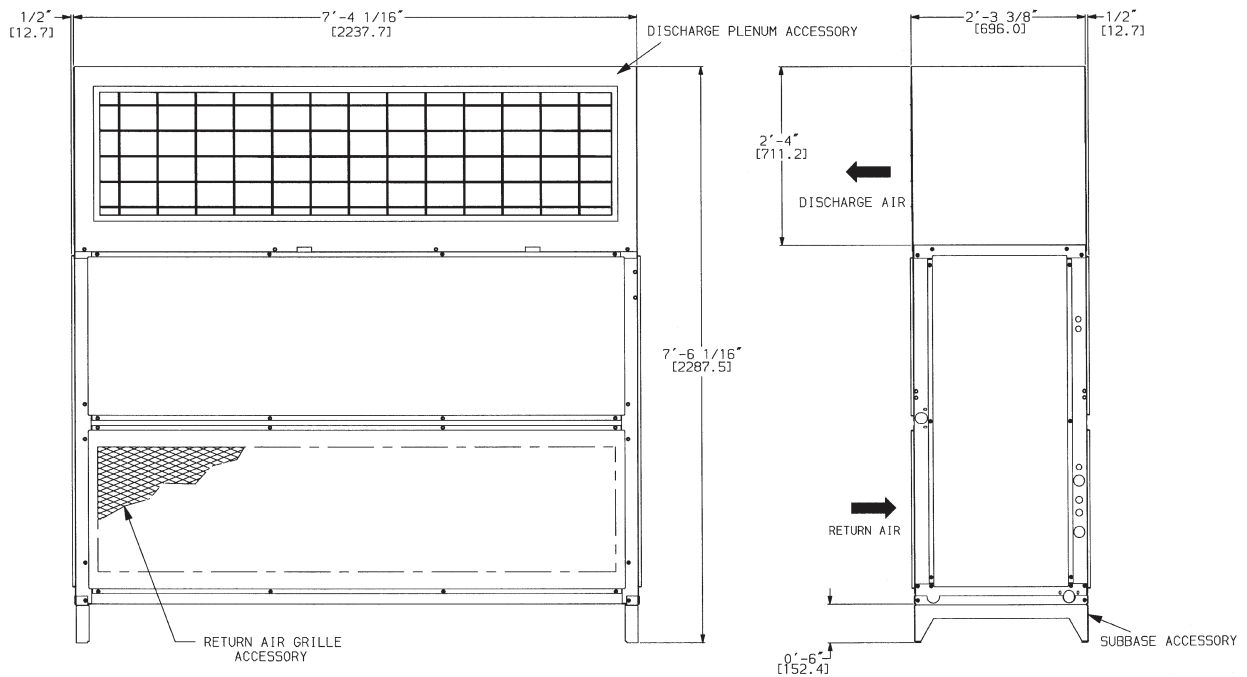

NOTE: Dimensions in [] are millimeters.

Accessory dimensions (cont)

Plenum, Return-Air Grille, and Subbase Accessories — FAS300/336

25-30 Ton Units

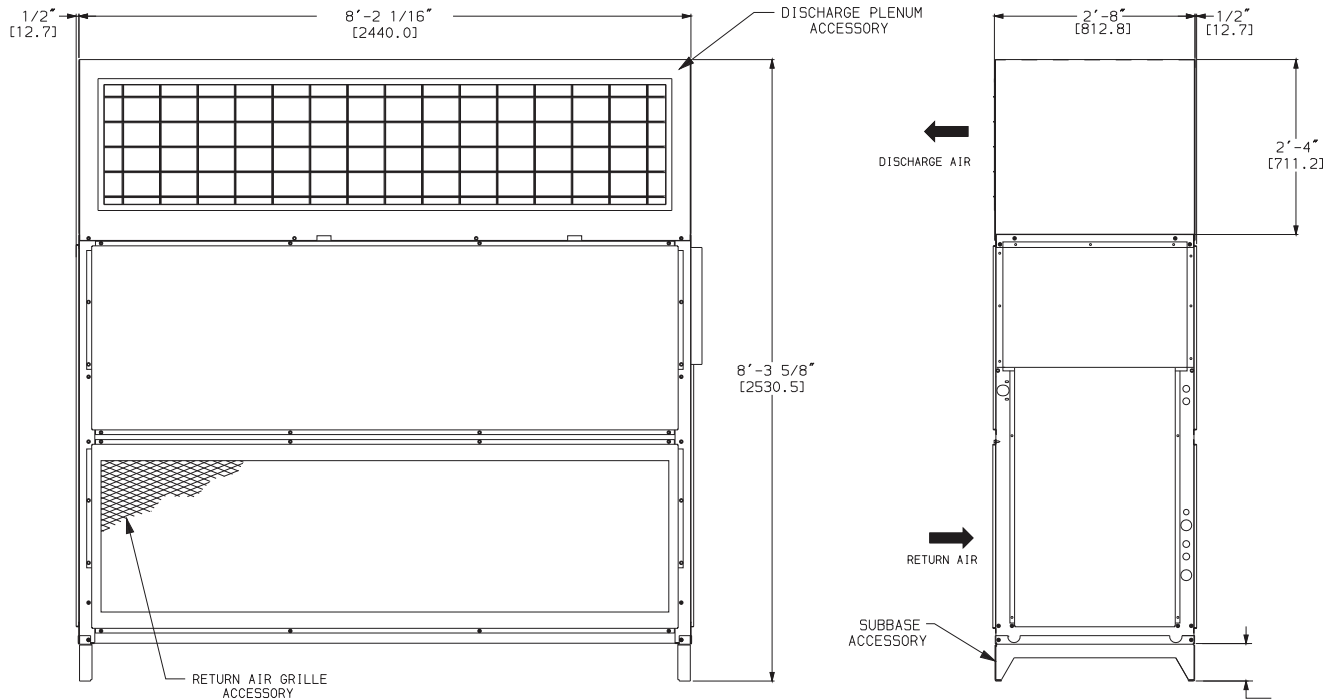

NOTE: Dimensions in [] are millimeters.

Accessory dimensions (cont)

Hot Water and Steam Coil Accessories — FAX072-120, FAS150-240

6-10 Ton Units

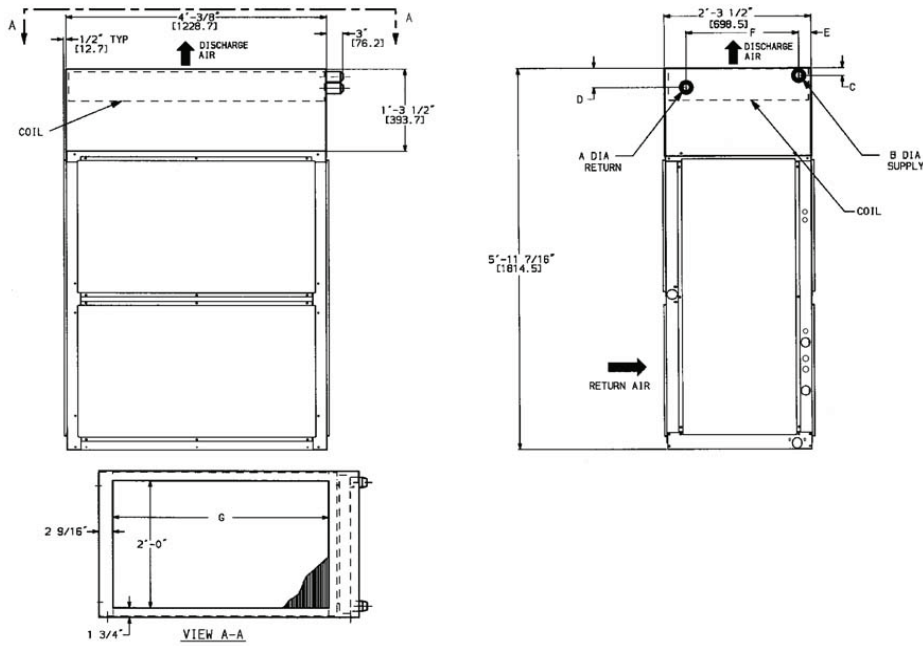

12.5-20 Ton Units

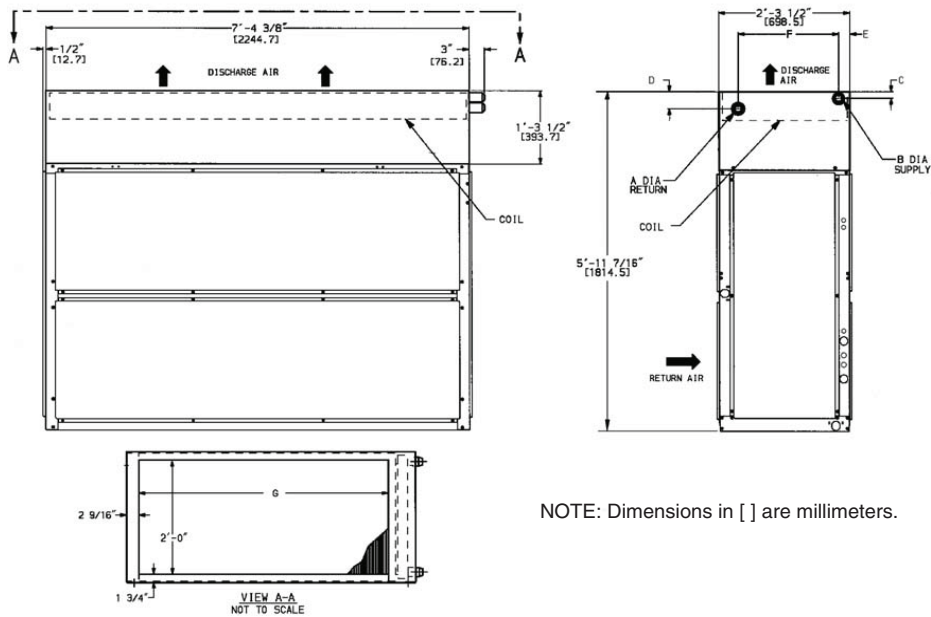

NOTE: Dimensions in [] are millimeters.

FAX072-120

DIMENSIONS	HOT WATER COIL	STEAM COIL
A	1-1/2" MPT [38.1]	1-1/2" MPT [38.1]
B	1-1/2" MPT [38.1]	2-1/2" MPT [63.5]
C	2-3/8" [60.3]	3-1/8" [79.4]
D	4-7/8" [123.8]	3-1/8" [79.4]
E	2-1/8" [54.0]	4-9/16" [115.8]
F	1'-11-1/4" [590.6]	1'-9" [584.2]
G	3'-4" [1016.0]	3'-4" [1016.0]

FAS150-240

DIMENSIONS	HOT WATER COIL	STEAM COIL
A	2" MPT [50.8]	1-1/2" MPT [38.1]
B	2" MPT [50.8]	2-1/2" MPT [63.5]
C	2-3/8" [60.3]	3-1/8" [79.4]
D	4-7/8" [123.8]	3-1/8" [79.4]
E	2-1/8" [54.0]	4-9/16" [115.8]
F	1'-11-1/4" [590.6]	1'-9" [584.2]
G	6'-8" [2032.0]	3'-4" [1016.0]

Accessory dimensions (cont)

Hot Water and Steam Coil Accessories — FAS300-336

25-30 Ton Units

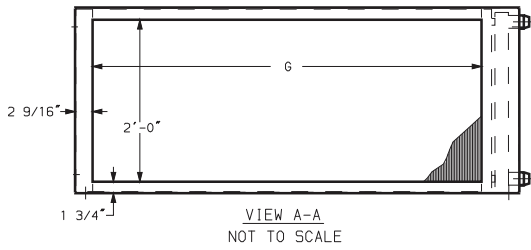
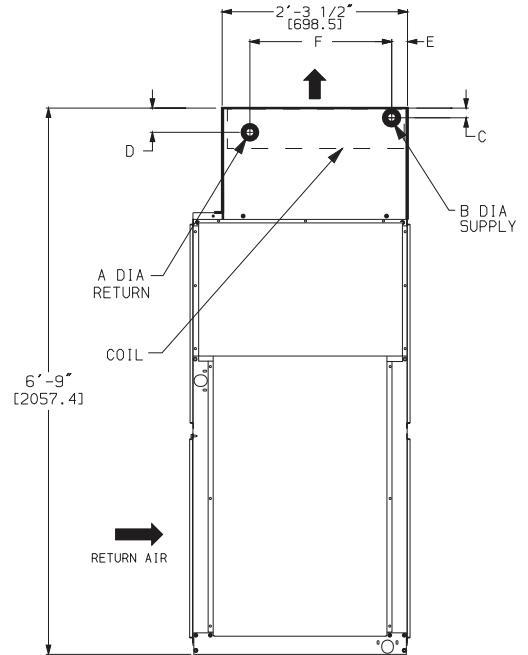
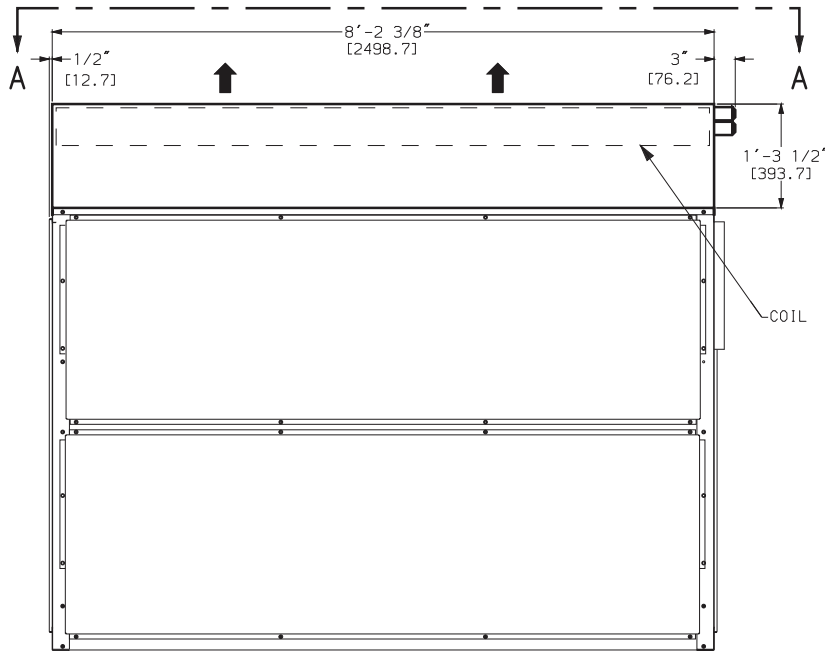

FAS300-336

DIMENSIONS	HOT WATER COIL	STEAM COIL
A	2" MPT [50.8]	1-1/2" MPT [38.1]
B	2" MPT [50.8]	2-1/2" MPT [63.5]
C	2-3/8" [60.3]	3-1/8" [9.4]
D	4-7/8" [123.8]	3-1/8" [79.4]
E	2-1/8" [54.0]	4-9/16" [115.8]
F	1'-11-1/4" [590.6]	1'-9" [584.2]
G	7'-6" [2286.0]	7'-6" [2286.0]

NOTE: Dimensions in [] are millimeters.

Accessory dimensions (cont)

Economizer Accessory — FAX072-120, FAS150-336

6-10 Ton Units

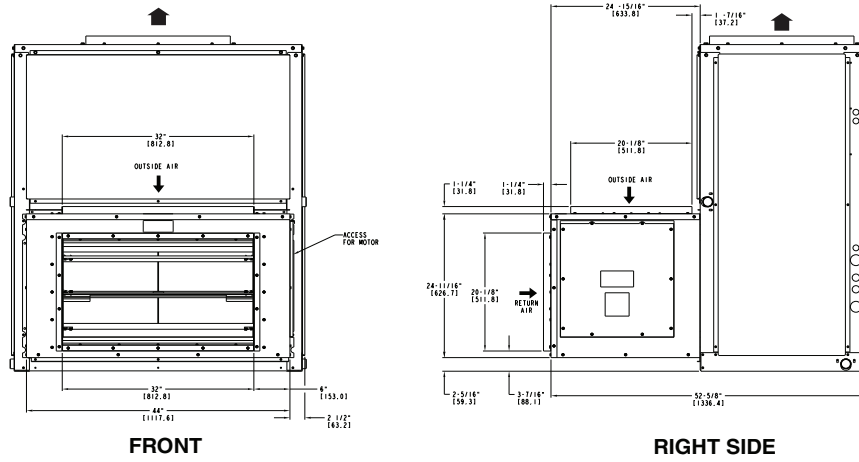

12.5-20 Ton Units

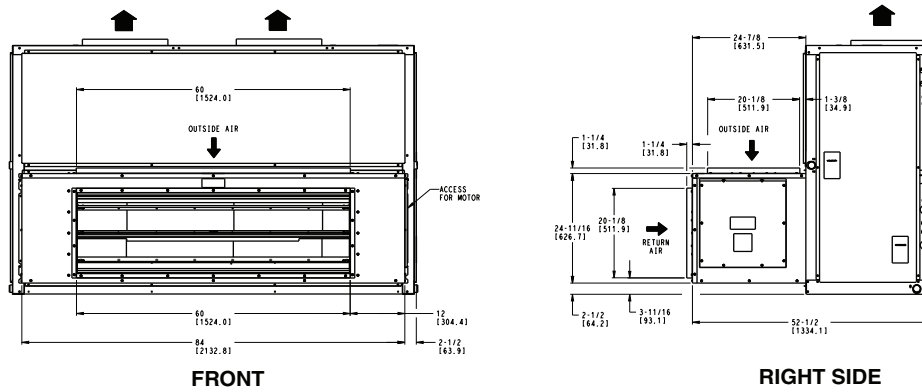

25-30 Ton Units

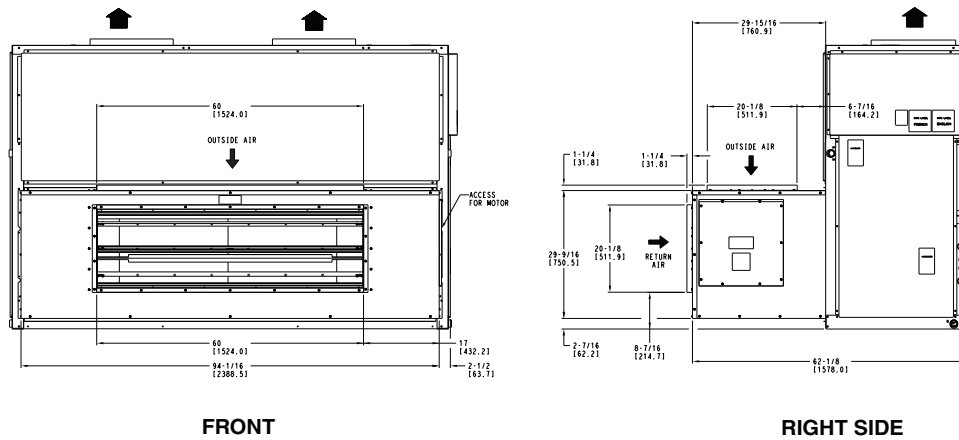

NOTES:

1. For horizontal unit applications, economizer can be attached to end of unit opposite duct connections.
2. Dimensions in [] are in millimeters.

Accessory dimensions (cont)

Electric Heater Accessory — Sizes 072-336

6-10 Ton Units

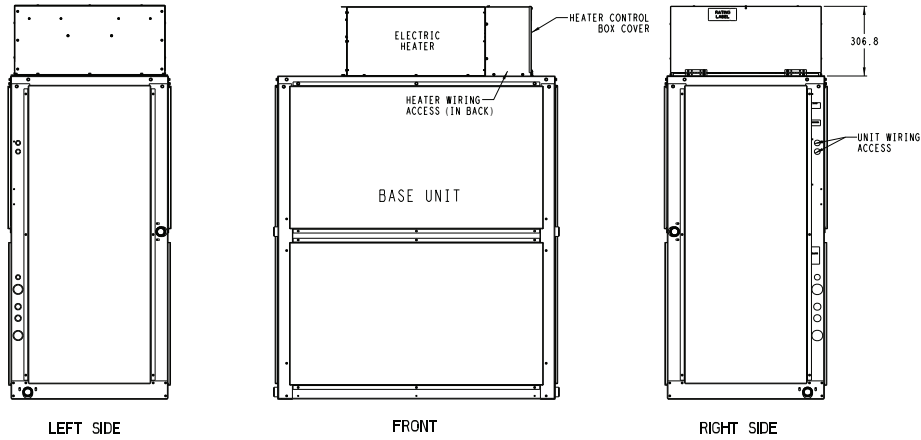
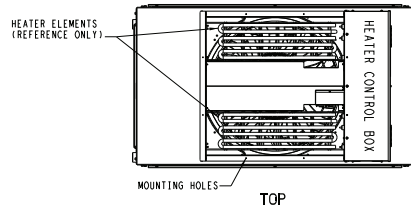

12.5-30 Ton Units

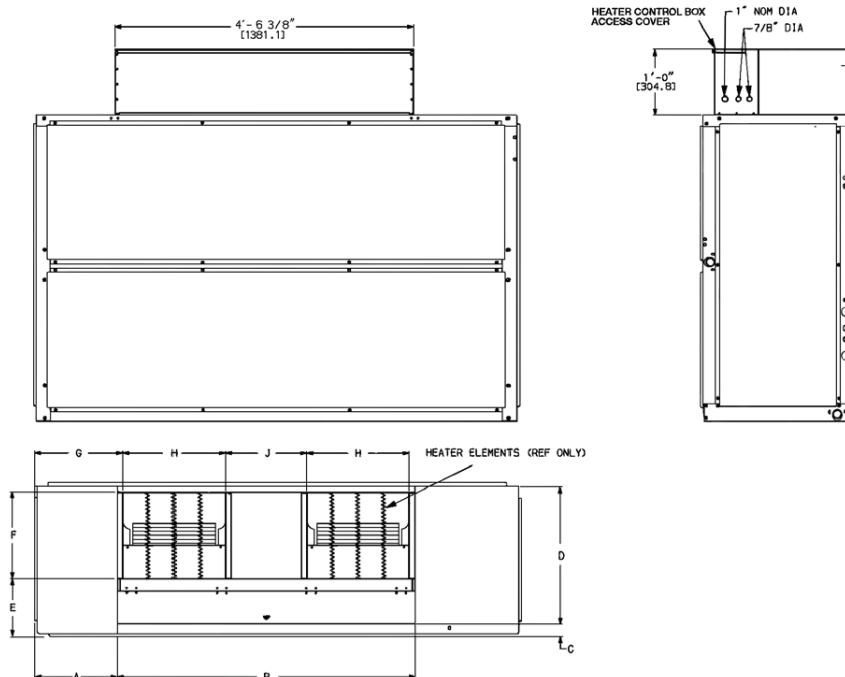

FAS UNIT SIZE	A	B	C	D	E	F	G	H	J
150-240	1' - 3-1/4" [387.4]	4' - 6" [1381.1]	2-5/16" [58.7]	2' - 1-1/4" [641.4]	10-5/8" [269.9]	1' - 4" [406.4]	1' - 4-5/16" [414.3]	1' - 6-3/4" [476.3]	1' - 7/8" [327.0]
300, 336	1' - 3-3/8" [390.5]	5' - 4-7/8" [1636.8]	2-1/16" [52.4]	2' - 6-3/16" [766.8]	1' - 1/4" [311.2]	1' - 7" [482.6]	1' - 4-5/16" [414.3]	1' - 10" [558.8]	1' - 4-7/16" [417.1]

NOTE: Dimensions in [] are in millimeters.

Performance data

FAX072-120 Cooling Capacities^{a,b,c,d,e}

UNIT FAX	EVAPORATOR AIR		COIL REFRIGERANT TEMP (°F) ^f									
	Airflow (cfm)	Ewb (°F)	30		35		40		45		50	
			TC	SHC	TC	SHC	TC	SHC	TC	SHC	TC	SHC
072	1,800	72	124	60	113	55	101	49	87	43	71	37
		67	104	64	93	59	81	53	67	47	52	40
		62	86	68	75	62	63	56	49	49	42	42
	2,400	72	143	69	131	64	117	58	101	52	83	44
		67	121	76	108	70	94	64	78	57	60	50
		62	101	83	88	76	73	69	60	60	51	51
	3,000	72	158	77	144	71	129	65	111	58	92	51
		67	134	86	121	80	105	73	87	66	67	58
		62	113	95	98	88	82	80	70	70	59	59
091	2,250	72	155	75	141	68	126	61	108	54	89	46
		67	130	80	116	73	101	66	83	59	64	51
		62	108	85	94	78	78	70	62	62	52	52
	3,000	72	179	86	164	80	146	72	126	64	103	56
		67	151	95	136	88	118	80	98	71	75	62
		62	126	103	110	95	92	86	76	76	64	64
	3,750	72	197	96	180	89	161	82	139	73	115	63
		67	168	108	151	100	131	92	109	82	84	72
		62	141	119	122	110	103	100	87	87	74	74
120	3,000	72	200	96	182	88	161	79	138	70	113	60
		67	168	104	150	96	130	86	107	76	83	66
		62	140	112	121	102	101	92	82	82	69	69
	4,000	72	228	111	208	102	185	93	159	83	130	71
		67	194	124	174	114	150	104	124	93	96	81
		62	162	135	141	124	119	113	99	99	84	84
	5,000	72	250	123	228	114	204	105	175	94	143	81
		67	214	140	192	130	166	119	138	107	106	94
		62	179	155	156	143	133	130	113	113	96	96

NOTE(S):

- a. Ratings based on approximately 15°F superheat leaving coil.
- b. Direct interpolation is permissible. Do not extrapolate.
- c. Dashes indicate coil loading limits are exceeded.
- d. Evaporator fan heat not deducted from ratings.
- e. See dry and wet bulb formulas below.
- f. SHC is based on 80°F db temperature of air entering evaporator coil.

Dry and Wet Bulb Formulas:

$$\text{Leaving db} = \text{entering db} - \frac{\text{sensible heat capacity (Btuh)}}{1.1 \times \text{cfm}}$$

$$\text{Leaving wb} = \text{wet-bulb temperature corresponding to enthalpy of air leaving coil (h}_{\text{wb}})$$

$$h_{\text{wb}} = h_{\text{ewb}} - \frac{\text{total capacity (Btuh)}}{4.5 \times \text{cfm}}$$

where h_{wb} = enthalpy of air entering coil

LEGEND

- db** — Dry Bulb Temperature (°F)
- SHC** — Sensible Heat Capacity (1000 Btuh)
- TC** — Total Capacity (1000 Btuh)
- wb** — Wet Bulb Temperature (°F)

Performance data (cont)

FAS150-336 Cooling Capacities^{a,b,c,d,e}

UNIT FAS	EVAPORATOR AIR		COIL REFRIGERANT TEMP (°F) ^f									
	AIRFLOW (cfm)	Ewb (°F)	30		35		40		45		50	
			TC	SHC	TC	SHC	TC	SHC	TC	SHC	TC	SHC
150	3,750	72	251	121	228	110	202	99	173	87	140	74
		67	210	129	187	118	161	106	133	94	102	81
		62	174	138	150	126	125	113	100	100	84	84
	5,000	72	289	139	263	128	233	116	200	103	162	88
		67	244	154	218	141	188	128	155	114	119	99
		62	203	167	176	153	146	138	121	121	102	102
	6,250	72	319	155	290	143	258	131	221	116	180	101
		67	271	174	242	161	209	147	172	132	133	115
		62	226	192	196	177	164	160	139	139	118	118
180	4,500	72	310	150	281	136	249	122	214	108	174	92
		67	260	160	231	145	199	131	165	116	127	100
		62	215	169	186	154	154	138	121	121	102	102
	6,000	72	361	175	329	161	292	145	250	128	205	110
		67	304	191	271	175	235	159	194	141	149	122
		62	254	206	220	189	183	170	149	149	125	125
	7,500	72	401	196	366	181	325	164	280	146	229	127
		67	340	218	304	201	263	183	218	164	167	143
		62	285	239	247	220	206	197	172	172	145	145
240	6,000	72	408	197	372	180	331	162	272	141	232	123
		67	344	213	307	195	266	176	220	156	169	135
		62	286	227	248	208	207	188	164	164	139	139
	8,000	72	470	228	429	210	382	191	329	170	269	147
		67	399	253	357	233	309	212	256	189	197	166
		62	333	275	290	254	242	230	202	202	170	170
	10,000	72	516	253	471	235	421	215	363	192	297	168
		67	440	287	395	266	343	244	284	219	220	193
		62	369	317	322	294	271	266	232	232	196	196
300	7,500	72	470	226	428	208	379	187	328	167	270	144
		67	395	246	354	227	307	205	255	183	197	159
		62	329	265	287	244	240	221	193	193	163	163
	10,000	72	535	260	487	240	434	219	376	196	310	171
		67	454	291	407	269	354	246	295	221	228	194
		62	380	320	332	296	279	268	235	235	199	199
	12,500	72	583	287	531	267	475	245	412	221	341	194
		67	499	329	448	306	390	282	325	255	252	225
		62	420	367	367	341	310	310	269	269	228	228
336	9,000	72	564	271	513	249	456	225	394	200	324	173
		67	476	296	425	272	368	246	306	220	236	191
		62	395	319	344	293	288	265	231	231	195	195
	12,500	72	642	312	584	288	521	263	451	235	372	205
		67	545	349	489	323	425	295	353	265	273	233
		62	456	383	398	355	334	322	281	281	238	238
	15,000	72	699	345	637	320	570	294	495	265	410	233
		67	598	394	537	367	468	338	390	306	303	270
		62	503	440	440	409	371	371	322	322	273	273

NOTE(S):

- Ratings based on approximately 15°F superheat leaving coil.
- Direct interpolation is permissible. Do not extrapolate.
- Dashes indicate coil loading limits are exceeded.
- Evaporator fan heat not deducted from ratings.
- See dry and wet bulb formulas below.
- SHC is based on 80°F db temperature of air entering evaporator coil.

Dry and Wet Bulb Formulas:

$$\text{Leaving db} = \text{entering db} - \frac{\text{sensible heat capacity (Btuh)}}{1.1 \times \text{cfm}}$$

$$\text{Leaving wb} = \text{wet-bulb temperature corresponding to enthalpy of air leaving coil (h}_{wb}\text{)}$$

$$h_{wb} = h_{ewb} - \frac{\text{total capacity (Btuh)}}{4.5 \times \text{cfm}}$$

where h_{wb} = enthalpy of air entering coil

LEGEND

- db** — Dry Bulb Temperature (°F)
- SHC** — Sensible Heat Capacity (1000 Btuh)
- TC** — Total Capacity (1000 Btuh)
- wb** — Wet Bulb Temperature (°F)

Performance data (cont)

Hydronic Heating Capacities^{a,b,c}

UNIT	AIRFLOW	1-ROW STEAM ^d		2-ROW HOT WATER COIL ^e			
		Cap.	Ldb	Cap.	Ldb	Water Flow (Gpm)	PD
FAX072	1,800	146	134	156.0	140	15.6	3.4
	2,400	173	126	183.0	131	18.3	4.3
	3,000	209	123	206.0	124	20.6	5.2
FAX091	2,250	168	129	174.0	133	17.4	4.0
	3,000	209	123	206.0	124	20.6	5.2
	3,750	240	117	238.0	118	23.8	6.5
FAX120	3,000	209	123	299.0	152	29.9	5.0
	4,000	243	115	275.0	124	27.5	6.6
	5,000	279	111	316.0	119	31.6	8.2
FAS150	3,750	370	150	362.0	149	36.2	4.2
	5,000	425	137	409.0	136	40.9	5.1
	6,250	465	128	456.0	128	45.6	6.0
FAS180	4,500	402	141	412.0	145	41.2	4.5
	6,000	458	129	471.0	133	47.1	5.5
	7,500	479	118	529.0	125	52.9	6.6
FAS240	6,000	458	129	506.0	138	50.6	5.1
	8,000	487	115	584.0	128	58.4	6.3
	10,000	499	105	652.0	120	65.2	7.5
FAS300	7,500	511	122	649.0	140	64.9	5.7
	10,000	575	112	752.0	130	75.2	7.1
	12,500	626	106	842.0	122	84.2	8.5
FAS336	9,000	560	117	735.0	136	73.5	6.2
	12,000	621	107	850.0	126	85.0	7.8
	15,000	670	101	950.0	119	95.0	9.3

NOTE(S):

- a. Maximum operating limits for heating coils: 20 psig at 260°F.
- b. See leaving dry bulb formula below.
- c. See Heating Correction Factors table.
- d. Based on 5 psig steam, 60° F entering-air temperature. All steam coils are non-freeze type.
- e. Based on 200° F entering water, 20° F water temperature drop, 60° F entering-air temperature.

Leaving dry bulb formula:

$$\text{Leaving db} = \text{ent db (°F)} + \frac{\text{Capacity (Btuh)}}{1.1 \times \text{cfm}}$$

LEGEND

- Cap. — Capacity (Btuh in 1000)
- Ldb — Leaving Air Dry Bulb Temp (°F)
- PD — Pressure Drop (ft water)

Heating Correction Factors

HOT WATER COIL						
Water Temp Drop (°F)	Entering Water Temp (°F)	Entering Water Temp (°F)				
		40	50	60	70	80
10	140	0.72	0.64	0.57	0.49	0.41
	160	0.89	0.81	0.74	0.66	0.58
	180	1.06	0.98	0.90	0.83	0.75
	200	1.22	1.15	1.07	1.00	0.92
	220	1.39	1.32	1.24	1.17	1.09
20	140	0.64	0.57	0.49	0.41	0.33
	160	0.81	0.74	0.66	0.58	0.51
	180	0.98	0.91	0.83	0.75	0.68
	200	1.15	1.08	1.00	0.93	0.85
30	220	1.32	1.25	1.17	1.10	1.02
	140	0.56	0.49	0.41	0.33	0.24
	160	0.74	0.66	0.58	0.51	0.43
	180	0.91	0.83	0.76	0.68	0.60
30	200	1.08	1.00	0.93	0.85	0.78
	220	1.25	1.18	1.10	1.03	0.95

STEAM COIL					
STEAM PRESSURE (psig)	Entering-Air Temperature (°F)				
	40	50	60	70	80
0	1.06	0.98	0.91	0.85	0.78
2	1.09	1.02	0.95	0.89	0.82
5	1.13	1.06	1.00	0.93	0.87

NOTE: Multiply capacity is given in the Hydronic Heating Capacities table by the correction factor for conditions at which unit is actually operating. Correct leaving-air temperature using formula in Note b of Hydronic Heating Capacities table.

Performance data (cont)

Duct Sound Power Levels (Lw)^{a,b,c}

MODEL	SIZE	CFM	db(A)	OCTAVE BAND CENTER FREQUENCY (Hz)						
				63	125	250	500	1000	2000	4000
FAX	072	2,400	86.3	93.2	89.2	85.2	84.2	80.2	78.2	74.2
	091	3,000	88.3	95.3	91.3	87.3	86.3	82.3	80.3	76.3
	120	4,000	91.6	98.6	94.6	90.6	89.6	85.6	83.6	79.6
FAS	150	5,000	91.1	97.3	93.3	89.3	90.3	84.3	82.3	78.3
	180	6,000	92.7	98.9	94.9	90.9	91.9	85.9	83.9	79.9
	240	8,000	96.4	102.6	98.6	94.6	95.6	89.6	87.6	83.6
	300	10,000	96.2	102.5	98.5	94.5	95.5	89.5	87.5	83.5
	336	12,000	98.5	104.7	100.7	96.7	97.7	91.7	89.7	85.7

NOTE(S):

- a. The estimated sound power levels are based upon the ASHRAE calculation approach from the ASHRAE 1987 HVAC Systems and Applications handbook, Chapter 52.
- b. Since this data is calculated, these sound power levels may be different than the actual sound power levels.
- c. The acoustic center of the unit is located at the geometric center of the unit.

LEGEND

ASHRAE — American Society of Heating, Refrigerating and Air Conditioning
 HVAC — Heating, Ventilation and Air Conditioning

Factory-Supplied Filter Pressure Drops

UNIT	AIRFLOW (cfm)	PRESSURE DROP (in. wg)
FAX072	1,400	0.05
	2,400	0.08
	3,000	0.11
FAX091	2,250	0.07
	3,000	0.11
	3,750	0.15
FAX120	3,000	0.11
	4,000	0.17
	5,000	0.23
FAS150	3,750	0.06
	5,000	0.10
	6,250	0.13
FAS180	4,500	0.08
	6,000	0.12
	7,500	0.17
FAS240	6,000	0.12
	8,000	0.19
	10,000	0.26
FAS300	7,500	0.15
	10,000	0.22
	12,500	0.30
FAS336	9,000	0.19
	12,000	0.29
	15,000	0.40

Accessory Plenum Air Throw Data (ft)^a

UNIT	AIRFLOW (cfm)	VANE DEFLECTION		
		Straight	21-1/2°	45°
FAX072	2,400	39	33	24
FAX091	3,000	45	38	28
FAX120	4,000	55	46	33
FAS150	5,000	45	38	28
FAS180	6,000	50	43	31
FAS240	8,000	60	51	37
FAS300	10,000	76	65	47
FAS336	12,000	85	72	52

NOTE(S):

- a. Throw distances shown are for 75 fpm terminal velocity. Use the multipliers below to determine throw values for other terminal velocities.

TERMINAL VELOCITY (fpm)	THROW FACTOR
50	x 1.50
100	x 0.75
150	x 0.50

Performance data (cont)

Accessory Pressure Drop — in. wg

UNIT	AIRFLOW (Cfm)	DISCHARGE PLENUM	RETURN AIR GRILLE	HOT WATER	STEAM	ELECTRIC	ECONOMIZER
FAX072	1,800	0.06	0.01	0.10	0.10	0.04	0.05
	2,400	0.10	0.01	0.16	0.16	0.06	0.07
	3,000	0.14	0.02	0.23	0.23	0.10	0.09
FAX091	2,250	0.09	0.01	0.15	0.15	0.06	0.06
	3,000	0.14	0.02	0.23	0.23	0.10	0.09
	3,750	0.21	0.03	0.35	0.35	0.15	0.15
FAX120	3,000	0.14	0.02	0.23	0.23	0.10	0.09
	4,000	0.22	0.04	0.37	0.37	0.17	0.17
	5,000	0.32	0.06	0.53	0.53	0.26	0.28
FAS150	3,750	0.07	0.01	0.11	0.11	0.04	0.05
	5,000	0.12	0.02	0.17	0.17	0.07	0.07
	6,250	0.17	0.02	0.25	0.25	0.11	0.11
FAS180	4,500	0.10	0.01	0.15	0.15	0.06	0.06
	6,000	0.16	0.02	0.23	0.23	0.10	0.09
	7,500	0.23	0.03	0.33	0.33	0.15	0.15
FAS240	6,000	0.16	0.02	0.23	0.23	0.10	0.09
	8,000	0.26	0.04	0.37	0.37	0.17	0.17
	10,000	0.37	0.06	0.53	0.53	0.26	0.28
FAS300	7,500	0.15	0.02	0.28	0.28	0.09	0.06
	10,000	0.24	0.03	0.44	0.44	0.16	0.09
	12,500	0.34	0.05	0.63	0.63	0.24	0.14
FAS336	9,000	0.20	0.03	0.37	0.37	0.13	0.08
	12,000	0.32	0.05	0.59	0.59	0.22	0.14
	15,000	0.46	0.07	0.85	0.85	0.34	0.21

Fan data

GENERAL FAN PERFORMANCE NOTES

1. Interpolation is permissible. Do not extrapolate.
2. External static pressure is the static pressure difference between the return duct and the supply duct plus the static pressure caused by any FIOPs or accessories.
3. Tabular data accounts for pressure loss due to clean filters, unit casing, wet coils, and highest gas heat exchanger (when gas heat unit).
4. Factory options and accessories may effect static pressure losses. Selection software is available, through your salesperson, to help you select the best motor/drive combination for your application.
5. The fan performance tables offer motor/drive recommendations. In cases when two motor/drive combinations would work, we recommend the lower horsepower option.
6. For information on the electrical properties of our motors, please see the Electrical Data section of this book.
7. For more information on the performance limits of our motors, see the Application Data section of this book.
8. The EPACT (Energy Policy Act of 1992, U.S.A.) regulates energy requirements for specific types of indoor fan motors. Motors regulated by EPACT include any general purpose, T-frame (three-digit, 143 and larger), single-speed, foot mounted, polyphase, squirrel cage induction motors of NEMA (National Electrical Manufacturers Association) design A and B, manufactured for use in the United States. Ranging from 1 to 200 Hp, these continuous-duty motors operate on 230 and 460 volt, 60 Hz power. If a motor does not fit into these specifications, the motor does not have to be replaced by an EPACT compliant energy-efficient motor. Variable-speed motors are exempt from EPACT compliance requirements.

Fan data (cont)

FAX072 Fan Data (rpm - bhp)

CFM	AVAILABLE EXTERNAL STATIC PRESSURE (in. wg)									
	0.2		0.4		0.6		0.8		1.0	
	rpm	bhp	rpm	bhp	rpm	bhp	rpm	bhp	rpm	bhp
1800	788	0.18	942	0.31	1081	0.48	1202	0.67	1308	0.88
1950	828	0.20	973	0.34	1107	0.52	1227	0.71	1333	0.92
2100	870	0.23	1005	0.37	1134	0.55	1252	0.75	1358	0.97
2250	914	0.26	1040	0.41	1163	0.59	1278	0.80	1383	1.02
2400	958	0.30	1077	0.45	1194	0.63	1305	0.84	1409	1.07
2550	1004	0.34	1115	0.50	1226	0.68	1334	0.89	1435	1.13
2700	1050	0.39	1155	0.55	1261	0.74	1364	0.95	1462	1.18
2850	1097	0.44	1197	0.60	1297	0.79	1395	1.01	1491	1.25
3000	1144	0.50	1239	0.66	1334	0.86	1429	1.08	1521	1.32

CFM	AVAILABLE EXTERNAL STATIC PRESSURE (in. wg)									
	1.2		1.4		1.6		1.8		2.0	
	rpm	bhp	rpm	bhp	rpm	bhp	rpm	bhp	rpm	bhp
1800	1403	1.09	1491	1.32	1571	1.55	1647	1.79	1718	2.04
1950	1429	1.14	1517	1.38	1598	1.62	1674	1.87	1745	2.13
2100	1454	1.20	1542	1.44	1624	1.69	1700	1.95	1772	2.21
2250	1479	1.25	1568	1.50	1650	1.76	1726	2.02	1799	2.30
2400	1504	1.31	1593	1.57	1675	1.83	1752	2.11	1825	2.39
2550	1529	1.37	1618	1.64	1700	1.91	1777	2.19	1850	2.48
2700	1555	1.44	1643	1.70	1725	1.98	1802	2.27	1875	2.57
2850	1582	1.50	1668	1.78	1750	2.06	1827	2.36	1900	2.66
3000	1610	1.58	1695	1.86	1775	2.14	1852	2.45	1925	2.76

Medium Static 788-1695 rpm, 1.86 max bhp

High Static 788-1925 rpm, 2.76 max bhp

FAX072 Medium Static Fan Data (rpm - VDC)

CFM	AVAILABLE EXTERNAL STATIC PRESSURE (in. wg)									
	0.2		0.4		0.6		0.8		1.0	
	rpm	Vdc	rpm	Vdc	rpm	Vdc	rpm	Vdc	rpm	Vdc
1800	788	3.8	942	4.6	1081	5.3	1202	5.9	1308	6.4
1950	828	4.0	973	4.7	1107	5.4	1227	6.0	1333	6.6
2100	870	4.2	1005	4.9	1134	5.5	1252	6.2	1358	6.7
2250	914	4.4	1040	5.1	1163	5.7	1278	6.3	1383	6.8
2400	958	4.6	1077	5.3	1194	5.9	1305	6.4	1409	7.0
2550	1004	4.9	1115	5.4	1226	6.0	1334	6.6	1435	7.1
2700	1050	5.1	1155	5.7	1261	6.2	1364	6.7	1462	7.2
2850	1097	5.4	1197	5.9	1297	6.4	1395	6.9	1491	7.4
3000	1144	5.6	1239	6.1	1334	6.6	1429	7.1	1521	7.5

CFM	AVAILABLE EXTERNAL STATIC PRESSURE (in. wg)									
	1.2		1.4		1.6		1.8		2.0	
	rpm	Vdc	rpm	Vdc	rpm	Vdc	rpm	Vdc	rpm	Vdc
1800	1403	6.9	1491	7.4	—	—	—	—	—	—
1950	1429	7.1	1517	7.5	—	—	—	—	—	—
2100	1454	7.2	1542	7.6	—	—	—	—	—	—
2250	1479	7.3	1568	7.8	—	—	—	—	—	—
2400	1504	7.4	1593	7.9	—	—	—	—	—	—
2550	1529	7.6	1618	8.0	—	—	—	—	—	—
2700	1555	7.7	1643	8.2	—	—	—	—	—	—
2850	1582	7.9	1668	8.3	—	—	—	—	—	—
3000	1610	8.0	1695	8.4	—	—	—	—	—	—

Medium Static 788-1695 rpm

Fan data (cont)

FAX072 High Static Fan Data (rpm - VDC)

CFM	AVAILABLE EXTERNAL STATIC PRESSURE (in. wg)									
	0.2		0.4		0.6		0.8		1.0	
	rpm	Vdc	rpm	Vdc	rpm	Vdc	rpm	Vdc	rpm	Vdc
1800	788	3.5	942	4.2	1081	4.8	1202	5.4	1308	5.9
1950	828	3.7	973	4.3	1107	5.0	1227	5.5	1333	6.0
2100	870	3.9	1005	4.5	1134	5.1	1252	5.6	1358	6.1
2250	914	4.1	1040	4.6	1163	5.2	1278	5.7	1383	6.2
2400	958	4.3	1077	4.8	1194	5.4	1305	5.9	1409	6.3
2550	1004	4.5	1115	5.0	1226	5.5	1334	6.0	1435	6.5
2700	1050	4.7	1155	5.2	1261	5.7	1364	6.1	1462	6.6
2850	1097	4.9	1197	5.4	1297	5.8	1395	6.3	1491	6.7
3000	1144	5.1	1239	5.6	1334	6.0	1429	6.4	1521	6.9

CFM	AVAILABLE EXTERNAL STATIC PRESSURE (in. wg)									
	1.2		1.4		1.6		1.8		2.0	
	rpm	Vdc	rpm	Vdc	rpm	Vdc	rpm	Vdc	rpm	Vdc
1800	1403	6.3	1491	6.7	1571	7.1	1647	7.4	1718	7.8
1950	1429	6.4	1517	6.8	1598	7.2	1674	7.6	1745	7.9
2100	1454	6.6	1542	7.0	1624	7.3	1700	7.7	1772	8.0
2250	1479	6.7	1568	7.1	1650	7.5	1726	7.8	1799	8.1
2400	1504	6.8	1593	7.2	1675	7.6	1752	7.9	1825	8.3
2550	1529	6.9	1618	7.3	1700	7.7	1777	8.0	1850	8.4
2700	1555	7.0	1643	7.4	1725	7.8	1802	8.2	1875	8.5
2850	1582	7.1	1668	7.5	1750	7.9	1827	8.3	1900	8.6
3000	1610	7.3	1695	7.7	1775	8.0	1852	8.4	1925	8.7

High Static 788-1925 rpm

Fan data (cont)

FAX091 Fan Data (rpm - bhp)

CFM	AVAILABLE EXTERNAL STATIC PRESSURE (in. wg)									
	0.2		0.4		0.6		0.8		1.0	
	rpm	bhp	rpm	bhp	rpm	bhp	rpm	bhp	rpm	bhp
2250	884	0.23	1009	0.37	1131	0.54	1247	0.74	1354	0.95
2440	937	0.27	1053	0.42	1168	0.59	1279	0.79	1383	1.01
2625	991	0.32	1099	0.47	1206	0.64	1311	0.84	1412	1.07
2815	1048	0.37	1149	0.53	1249	0.70	1348	0.90	1445	1.13
3000	1103	0.43	1199	0.59	1293	0.77	1386	0.97	1478	1.20
3190	1161	0.50	1252	0.66	1340	0.85	1428	1.05	1516	1.28
3375	1218	0.57	1304	0.74	1388	0.93	1471	1.14	1554	1.37
3565	1277	0.66	1359	0.83	1438	1.02	1517	1.24	1596	1.47
3750	1335	0.75	1413	0.93	1489	1.13	1564	1.34	1639	1.58

CFM	AVAILABLE EXTERNAL STATIC PRESSURE (in. wg)									
	1.2		1.4		1.6		1.8		2.0	
	rpm	bhp	rpm	bhp	rpm	bhp	rpm	bhp	rpm	bhp
2250	1452	1.18	1542	1.43	1625	1.68	1703	1.94	1776	2.21
2440	1480	1.25	1570	1.50	1653	1.76	1731	2.03	1805	2.31
2625	1507	1.31	1597	1.57	1680	1.83	1759	2.11	1833	2.40
2815	1537	1.38	1625	1.64	1708	1.91	1787	2.20	1861	2.50
3000	1568	1.45	1654	1.72	1736	2.00	1814	2.29	1888	2.60
3190	1602	1.54	1685	1.80	1765	2.09	1842	2.39	1916	2.70
3375	1636	1.62	1717	1.90	1795	2.18	1871	2.49	1944	2.81
3565	1675	1.73	1752	2.00	1828	2.29	1902	2.60	1973	2.92
3750	1714	1.83	1788	2.11	1862	2.41	1933	2.71	2003	3.04

Medium Static 884-1788 rpm, 1.84 max bhp

High Static 884-2003 rpm, 2.70 max bhp

FAX091 Medium Static Fan Data (rpm - VDC)

CFM	AVAILABLE EXTERNAL STATIC PRESSURE (in. wg)									
	0.2		0.4		0.6		0.8		1.0	
	rpm	Vdc	rpm	Vdc	rpm	Vdc	rpm	Vdc	rpm	Vdc
2250	884	4.3	1009	4.9	1131	5.5	1247	6.1	1354	6.7
2440	937	4.5	1053	5.1	1168	5.7	1279	6.3	1383	6.8
2625	991	4.8	1099	5.4	1206	5.9	1311	6.5	1412	7.0
2815	1048	5.1	1149	5.6	1249	6.1	1348	6.6	1445	7.1
3000	1103	5.4	1199	5.9	1293	6.4	1386	6.8	1478	7.3
3190	1161	5.7	1252	6.2	1340	6.6	1428	7.1	1516	7.5
3375	1218	6.0	1304	6.4	1388	6.9	1471	7.3	1554	7.7
3565	1277	6.3	1359	6.7	1438	7.1	1517	7.5	1596	7.9
3750	1335	6.6	1413	7.0	1489	7.4	1564	7.8	1639	8.1

CFM	AVAILABLE EXTERNAL STATIC PRESSURE (in. wg)									
	1.2		1.4		1.6		1.8		2.0	
	rpm	Vdc	rpm	Vdc	rpm	Vdc	rpm	Vdc	rpm	Vdc
2250	1452	7.2	1542	7.6	—	—	—	—	—	—
2440	1480	7.3	1570	7.8	—	—	—	—	—	—
2625	1507	7.5	1597	7.9	—	—	—	—	—	—
2815	1537	7.6	1625	8.1	—	—	—	—	—	—
3000	1568	7.8	1654	8.2	—	—	—	—	—	—
3190	1602	8.0	1685	8.4	—	—	—	—	—	—
3375	1636	8.1	1717	8.5	—	—	—	—	—	—
3565	1675	8.3	1752	8.7	—	—	—	—	—	—
3750	1714	8.5	1788	8.9	—	—	—	—	—	—

Medium Static 884-1788 rpm

Fan data (cont)

FAX091 High Static Fan Data (rpm - VDC)

CFM	AVAILABLE EXTERNAL STATIC PRESSURE (in. wg)									
	0.2		0.4		0.6		0.8		1.0	
	rpm	Vdc	rpm	Vdc	rpm	Vdc	rpm	Vdc	rpm	Vdc
2250	884	3.9	1009	4.5	1131	5.1	1247	5.6	1354	6.1
2440	937	4.2	1053	4.7	1168	5.2	1279	5.7	1383	6.2
2625	991	4.4	1099	4.9	1206	5.4	1311	5.9	1412	6.4
2815	1048	4.7	1149	5.1	1249	5.6	1348	6.1	1445	6.5
3000	1103	4.9	1199	5.4	1293	5.8	1386	6.2	1478	6.7
3190	1161	5.2	1252	5.6	1340	6.0	1428	6.4	1516	6.8
3375	1218	5.5	1304	5.9	1388	6.3	1471	6.6	1554	7.0
3565	1277	5.7	1359	6.1	1438	6.5	1517	6.8	1596	7.2
3750	1335	6.0	1413	6.4	1489	6.7	1564	7.1	1639	7.4

CFM	AVAILABLE EXTERNAL STATIC PRESSURE (in. wg)									
	1.2		1.4		1.6		1.8		2.0	
	rpm	Vdc	rpm	Vdc	rpm	Vdc	rpm	Vdc	rpm	Vdc
2250	1452	6.5	1542	7.0	1625	7.3	1703	7.7	1776	8.0
2440	1480	6.7	1570	7.1	1653	7.5	1731	7.8	1805	8.2
2625	1507	6.8	1597	7.2	1680	7.6	1759	8.0	1833	8.3
2815	1537	6.9	1625	7.3	1708	7.7	1787	8.1	1861	8.4
3000	1568	7.1	1654	7.5	1736	7.9	1814	8.2	1888	8.6
3190	1602	7.2	1685	7.6	1765	8.0	1842	8.3	1916	8.7
3375	1636	7.4	1717	7.8	1795	8.1	1871	8.5	1944	8.8
3565	1675	7.6	1752	7.9	1828	8.3	1902	8.6	1973	9.0
3750	1714	7.8	1788	8.1	1862	8.4	1933	8.8	2003	9.1

High Static 884-2003 rpm

Fan data (cont)

FAX120 Fan Data (rpm - bhp)

CFM	AVAILABLE EXTERNAL STATIC PRESSURE (in. wg)									
	0.2		0.4		0.6		0.8		1.0	
	rpm	bhp	rpm	bhp	rpm	bhp	rpm	bhp	rpm	bhp
3000	1080	0.40	1175	0.55	1268	0.72	1361	0.92	1453	1.14
3250	1154	0.48	1243	0.64	1329	0.81	1415	1.01	1501	1.24
3500	1229	0.57	1312	0.74	1393	0.92	1473	1.13	1553	1.35
3750	1305	0.68	1384	0.86	1459	1.04	1534	1.25	1609	1.48
4000	1381	0.80	1456	0.99	1527	1.18	1598	1.40	1668	1.63
4250	1458	0.94	1529	1.13	1597	1.34	1664	1.56	1730	1.79
4500	1535	1.09	1603	1.29	1668	1.50	1731	1.73	1794	1.97
4750	1613	1.26	1678	1.47	1740	1.69	1800	1.92	1860	2.17
5000	1691	1.45	1753	1.67	1813	1.90	1870	2.14	1927	2.39

CFM	AVAILABLE EXTERNAL STATIC PRESSURE (in. wg)									
	1.2		1.4		1.6		1.8		2.0	
	rpm	bhp	rpm	bhp	rpm	bhp	rpm	bhp	rpm	bhp
3000	1543	1.38	1629	1.64	1712	1.91	1791	2.20	1866	2.50
3250	1586	1.48	1668	1.74	1748	2.02	1825	2.31	1899	2.62
3500	1632	1.59	1711	1.86	1787	2.14	1862	2.44	1935	2.75
3750	1683	1.73	1757	1.99	1830	2.28	1902	2.58	1972	2.89
4000	1738	1.88	1807	2.14	1877	2.43	1945	2.73	2013	3.05
4250	1795	2.04	1861	2.31	1927	2.60	1992	2.90	—	—
4500	1856	2.23	1918	2.50	1980	2.79	2042	3.09	—	—
4750	1919	2.43	1977	2.71	2036	3.00	—	—	—	—
5000	1983	2.66	2039	2.94	—	—	—	—	—	—

Medium Static 1080-1918 rpm, 2.50 max bhp

High Static 1080-2013 rpm, 3.09 max bhp

FAX120 Medium Static Fan Data (rpm - VDC)

CFM	AVAILABLE EXTERNAL STATIC PRESSURE (in. wg)									
	0.2		0.4		0.6		0.8		1.0	
	rpm	Vdc	rpm	Vdc	rpm	Vdc	rpm	Vdc	rpm	Vdc
3000	1080	5.3	1175	5.8	1268	6.2	1361	6.7	1453	7.2
3250	1154	5.6	1243	6.1	1329	6.5	1415	7.0	1501	7.4
3500	1229	6.0	1312	6.5	1393	6.9	1473	7.3	1553	7.7
3750	1305	6.4	1384	6.8	1459	7.2	1534	7.6	1609	8.0
4000	1381	6.8	1456	7.2	1527	7.6	1598	7.9	1668	8.3
4250	1458	7.2	1529	7.6	1597	7.9	1664	8.3	1730	8.6
4500	1535	7.6	1603	8.0	1668	8.3	1731	8.6	1794	8.9
4750	1613	8.0	1678	8.3	1740	8.7	1800	9.0	1860	9.3
5000	1691	8.4	1753	8.7	1813	9.0	1870	9.3	1927	9.6

CFM	AVAILABLE EXTERNAL STATIC PRESSURE (in. wg)									
	1.2		1.4		1.6		1.8		2.0	
	rpm	Vdc	rpm	Vdc	rpm	Vdc	rpm	Vdc	rpm	Vdc
3000	1543	7.6	1629	8.1	—	—	—	—	—	—
3250	1586	7.9	1668	8.3	—	—	—	—	—	—
3500	1632	8.1	1711	8.5	—	—	—	—	—	—
3750	1683	8.4	1757	8.8	—	—	—	—	—	—
4000	1738	8.7	1807	9.0	—	—	—	—	—	—
4250	1795	8.9	1861	9.3	—	—	—	—	—	—
4500	1856	9.3	1918	9.6	—	—	—	—	—	—
4750	1919	9.6	—	—	—	—	—	—	—	—
5000	—	—	—	—	—	—	—	—	—	—

Medium Static 1080-1918 rpm

Fan data (cont)

FAX120 High Static Fan Data (rpm - VDC)

CFM	AVAILABLE EXTERNAL STATIC PRESSURE (in. wg)									
	0.2		0.4		0.6		0.8		1.0	
	rpm	Vdc	rpm	Vdc	rpm	Vdc	rpm	Vdc	rpm	Vdc
3000	1080	4.8	1175	5.3	1268	5.7	1361	6.1	1453	6.6
3250	1154	5.2	1243	5.6	1329	6.0	1415	6.4	1501	6.8
3500	1229	5.5	1312	5.9	1393	6.3	1473	6.6	1553	7.0
3750	1305	5.9	1384	6.2	1459	6.6	1534	6.9	1609	7.3
4000	1381	6.2	1456	6.6	1527	6.9	1598	7.2	1668	7.5
4250	1458	6.6	1529	6.9	1597	7.2	1664	7.5	1730	7.8
4500	1535	6.9	1603	7.2	1668	7.5	1731	7.8	1794	8.1
4750	1613	7.3	1678	7.6	1740	7.9	1800	8.2	1860	8.4
5000	1691	7.7	1753	7.9	1813	8.2	1870	8.5	1927	8.7

CFM	AVAILABLE EXTERNAL STATIC PRESSURE (in. wg)									
	1.2		1.4		1.6		1.8		2.0	
	rpm	Vdc	rpm	Vdc	rpm	Vdc	rpm	Vdc	rpm	Vdc
3000	1543	7.0	1629	7.4	1712	7.7	1791	8.1	1866	8.5
3250	1586	7.2	1668	7.5	1748	7.9	1825	8.3	1899	8.6
3500	1632	7.4	1711	7.7	1787	8.1	1862	8.4	1935	8.8
3750	1683	7.6	1757	8.0	1830	8.3	1902	8.6	1972	8.9
4000	1738	7.9	1807	8.2	1877	8.5	1945	8.8	2013	9.1
4250	1795	8.1	1861	8.4	1927	8.7	1992	9.0	—	—
4500	1856	8.4	1918	8.7	1980	9.0	2042	9.3	—	—
4750	1919	8.7	1977	9.0	2036	9.2	—	—	—	—
5000	1983	9.0	2039	9.3	—	—	—	—	—	—

High Static 1080-2013 rpm

Fan data (cont)

Standard Fan, FAS150-336, 0.0-1.2 in. wg ESP, 60 Hz — English^{a,b}

UNIT	AIRFLOW (Cfm)	EXTERNAL STATIC PRESSURE (in. wg) ^c													
		0.0		0.2		0.4		0.6		0.8		1.0		1.2	
		Rpm	Bhp	Rpm	Bhp	Rpm	Bhp	Rpm	Bhp	Rpm	Bhp	Rpm	Bhp	Rpm	Bhp
FAS150	3750	410	0.43	467	0.55	567	0.83	649	1.12	721	1.41	<u>788</u>	<u>1.72</u>	<u>851</u>	<u>2.05</u>
	4300	455	0.62	504	0.74	599	1.05	679	1.38	<u>748</u>	<u>1.70</u>	<u>811</u>	<u>2.04</u>	<u>871</u>	<u>2.39</u>
	5000	514	0.92	556	1.06	641	1.39	718	1.76	<u>786</u>	<u>2.14</u>	<u>847</u>	<u>2.52</u>	<u>903</u>	<u>2.91</u>
	5700	575	1.32	612	1.47	686	1.82	<u>759</u>	<u>2.23</u>	<u>825</u>	<u>2.66</u>	<u>884</u>	<u>3.09</u>	<u>939</u>	<u>3.52</u>
	6250	624	1.71	657	1.87	725	2.24	<u>793</u>	<u>2.66</u>	<u>856</u>	<u>3.12</u>	<u>915</u>	<u>3.59</u>	<u>969</u>	<u>4.06</u>
FAS180	4500	437	0.61	483	0.72	576	1.01	660	1.35	<u>732</u>	<u>1.69</u>	<u>797</u>	<u>2.03</u>	<u>856</u>	<u>2.38</u>
	5300	499	0.95	538	1.07	617	1.37	696	1.74	<u>767</u>	<u>2.13</u>	<u>830</u>	<u>2.53</u>	<u>888</u>	<u>2.94</u>
	6000	555	1.34	590	1.48	659	1.79	<u>730</u>	<u>2.17</u>	<u>798</u>	<u>2.59</u>	<u>860</u>	<u>3.04</u>	<u>918</u>	<u>3.49</u>
	6800	620	1.91	651	2.06	712	2.39	<u>774</u>	<u>2.78</u>	<u>836</u>	<u>3.22</u>	<u>896</u>	<u>3.71</u>	<u>952</u>	<u>4.21</u>
FAS240	7500	677	2.52	706	2.69	<u>761</u>	<u>3.04</u>	<u>817</u>	<u>3.44</u>	<u>873</u>	<u>3.89</u>	<u>929</u>	<u>4.39</u>	<u>984</u>	<u>4.93</u>
	6,000	542	1.29	577	1.42	646	1.72	716	2.09	785	2.51	849	2.95	<u>907</u>	<u>3.40</u>
	7,000	620	1.99	652	2.15	711	2.48	771	2.85	831	3.28	<u>890</u>	<u>3.76</u>	<u>947</u>	<u>4.27</u>
	8,000	700	2.92	728	3.10	781	3.46	833	3.85	<u>885</u>	<u>4.29</u>	<u>938</u>	<u>4.78</u>	<u>990</u>	<u>5.32</u>
	9,000	781	4.10	806	4.30	854	4.71	<u>900</u>	<u>5.13</u>	<u>946</u>	<u>5.58</u>	<u>993</u>	<u>6.08</u>	<u>1039</u>	<u>6.62</u>
FAS300	10,000	862	5.56	<u>885</u>	<u>5.79</u>	<u>929</u>	<u>6.24</u>	<u>971</u>	<u>6.70</u>	<u>1012</u>	<u>7.18</u>	<u>1054</u>	<u>7.69</u>	<u>1096</u>	<u>8.24</u>
	7,500	476	1.39	510	1.58	579	1.99	644	2.40	701	2.81	752	3.29	804	3.96
	8,750	545	2.14	574	2.35	633	2.81	691	3.29	747	3.77	797	4.25	<u>842</u>	<u>4.76</u>
	10,000	615	3.12	641	3.36	692	3.87	743	4.41	794	4.96	<u>843</u>	<u>5.51</u>	<u>888</u>	<u>6.05</u>
	11,250	685	4.37	709	4.64	754	5.20	800	5.79	<u>845</u>	<u>6.40</u>	<u>891</u>	<u>7.02</u>	<u>935</u>	<u>7.64</u>
FAS336	12,500	756	5.92	778	6.22	819	6.83	860	7.47	<u>901</u>	<u>8.14</u>	<u>942</u>	<u>8.83</u>	<u>983</u>	<u>9.52</u>
	9,000	539	2.18	569	2.39	626	2.85	683	3.34	739	3.83	791	4.32	<u>837</u>	<u>4.82</u>
	10,500	620	3.37	646	3.62	695	4.13	744	4.68	793	5.25	<u>842</u>	<u>5.83</u>	<u>888</u>	<u>6.41</u>
	12,000	701	4.94	724	5.22	769	5.80	811	6.40	<u>854</u>	<u>7.04</u>	<u>897</u>	<u>7.69</u>	<u>940</u>	<u>8.36</u>
	13,500	783	6.95	804	7.27	<u>844</u>	<u>7.91</u>	<u>883</u>	<u>8.57</u>	<u>920</u>	<u>9.26</u>	<u>958</u>	<u>9.97</u>	<u>996</u>	<u>10.71</u>
15,000	<u>865</u>	<u>9.45</u>	<u>884</u>	<u>9.81</u>	<u>921</u>	<u>10.52</u>	<u>956</u>	<u>11.24</u>	<u>991</u>	<u>11.98</u>	<u>1025</u>	<u>12.75</u>	<u>1059</u>	<u>13.54</u>	

NOTE(S):

- a. Maximum allowable fan speed is 1200 rpm for all sizes.
- b. Fan performance is based on deductions for wet coil, clean 2 in. filters, and unit casing. See table below for factory-supplied filter pressure drop.
- c. **Bold** indicates field-supplied drive is required.
Plain type indicates standard motor and standard drive.
Underlining indicates a different motor and drive combination other than the standard motor and standard drive combination is required.

Factory-Supplied Pressure Drop — English

LEGEND

UNIT	AIRFLOW (Cfm)	PRESSURE DROP (in. wg)
FAS150	3,750	0.06
	5,000	0.10
	6,250	0.13
FAS180	4,500	0.08
	6,000	0.12
	7,500	0.17
FAS240	6,000	0.12
	8,000	0.19
	10,000	0.26
FAS300	7,500	0.15
	10,000	0.22
	12,500	0.30
FAS336	9,000	0.19
	12,000	0.29
	15,000	0.40

- Bhp** — Brake Horsepower Input to Fan
- ESP** — External Static Pressure

Fan data (cont)

Standard Fan, FAS150-336, 1.4-2.4 in. wg ESP, 60 Hz — English^{a,b}

UNIT	AIRFLOW (Cfm)	EXTERNAL STATIC PRESSURE (in. wg) ^c											
		1.4		1.6		1.8		2.0		2.2		2.4	
		Rpm	Bhp	Rpm	Bhp	Rpm	Bhp	Rpm	Bhp	Rpm	Bhp	Rpm	Bhp
FAS150	3750	<u>912</u>	<u>2.39</u>	<u>971</u>	<u>2.76</u>	<u>1028</u>	<u>3.14</u>	<u>1083</u>	<u>3.54</u>	1135	3.95	1185	4.36
	4300	<u>928</u>	<u>2.75</u>	<u>982</u>	<u>3.13</u>	<u>1036</u>	<u>3.53</u>	<u>1087</u>	<u>3.94</u>	1138	4.37	1187	4.81
	5000	<u>956</u>	<u>3.30</u>	<u>1007</u>	<u>3.71</u>	<u>1056</u>	<u>4.13</u>	1104	4.56	1151	5.00	1196	5.46
	5700	<u>990</u>	<u>3.96</u>	<u>1039</u>	<u>4.40</u>	<u>1086</u>	<u>4.85</u>	1130	5.31	1174	5.78	—	—
	6250	<u>1019</u>	<u>4.54</u>	<u>1067</u>	<u>5.02</u>	1112	5.50	1156	5.99	1198	6.49	—	—
FAS180	4500	<u>912</u>	<u>2.75</u>	<u>967</u>	<u>3.12</u>	<u>1019</u>	<u>3.52</u>	<u>1070</u>	<u>3.92</u>	<u>1120</u>	<u>4.35</u>	<u>1168</u>	<u>4.79</u>
	5300	<u>942</u>	<u>3.34</u>	<u>992</u>	<u>3.76</u>	<u>1041</u>	<u>4.18</u>	<u>1088</u>	<u>4.61</u>	<u>1134</u>	<u>5.06</u>	1179	5.52
	6000	<u>971</u>	<u>3.95</u>	<u>1020</u>	<u>4.40</u>	<u>1067</u>	<u>4.86</u>	<u>1112</u>	<u>5.33</u>	<u>1156</u>	<u>5.81</u>	1198	6.29
	6800	<u>1005</u>	<u>4.72</u>	<u>1054</u>	<u>5.23</u>	<u>1101</u>	<u>5.75</u>	<u>1145</u>	<u>6.27</u>	1187	6.79	—	—
	7500	<u>1036</u>	<u>5.48</u>	<u>1084</u>	<u>6.04</u>	<u>1131</u>	<u>6.61</u>	1174	7.17	—	—	—	—
FAS240	6,000	<u>961</u>	<u>3.86</u>	<u>1011</u>	<u>4.31</u>	<u>1058</u>	<u>4.77</u>	<u>1104</u>	<u>5.24</u>	<u>1147</u>	<u>5.71</u>	—	—
	7,000	<u>1000</u>	<u>4.79</u>	<u>1050</u>	<u>5.32</u>	<u>1097</u>	<u>5.85</u>	<u>1142</u>	<u>6.38</u>	<u>1184</u>	<u>6.91</u>	—	—
	8,000	<u>1041</u>	<u>5.88</u>	<u>1090</u>	<u>6.47</u>	<u>1137</u>	<u>7.07</u>	<u>1181</u>	<u>7.67</u>	—	—	—	—
	9,000	<u>1086</u>	<u>7.21</u>	<u>1133</u>	<u>7.82</u>	<u>1178</u>	<u>8.47</u>	—	—	—	—	—	—
	10,000	<u>1138</u>	<u>8.83</u>	<u>1180</u>	<u>9.46</u>	—	—	—	—	—	—	—	—
FAS300	7,500	<u>874</u>	<u>5.33</u>	<u>897</u>	<u>5.91</u>	<u>940</u>	<u>6.80</u>	<u>990</u>	<u>7.50</u>	—	—	—	—
	8,750	<u>886</u>	<u>5.36</u>	<u>930</u>	<u>6.31</u>	<u>982</u>	<u>7.32</u>	<u>1020</u>	<u>8.10</u>	—	—	—	—
	10,000	<u>930</u>	<u>6.60</u>	<u>969</u>	<u>7.00</u>	<u>1007</u>	<u>7.89</u>	<u>1045</u>	<u>8.71</u>	—	—	—	—
	11,250	<u>976</u>	<u>8.25</u>	<u>1014</u>	<u>8.86</u>	<u>1051</u>	<u>9.49</u>	1086	10.17	—	—	—	—
	12,500	<u>1023</u>	<u>10.20</u>	<u>1061</u>	<u>10.88</u>	1097	11.56	—	—	—	—	—	—
FAS336	9,000	<u>881</u>	<u>5.37</u>	<u>923</u>	<u>6.03</u>	<u>967</u>	<u>6.89</u>	<u>1020</u>	<u>8.25</u>	—	—	—	—
	10,500	<u>930</u>	<u>6.97</u>	<u>970</u>	<u>7.55</u>	<u>1008</u>	<u>8.17</u>	<u>1045</u>	<u>8.86</u>	—	—	—	—
	12,000	<u>981</u>	<u>9.02</u>	<u>1021</u>	<u>9.67</u>	—	—	—	—	—	—	—	—
	13,500	<u>1035</u>	<u>11.45</u>	—	—	—	—	—	—	—	—	—	—
	15,000	—	—	—	—	—	—	—	—	—	—	—	—

NOTE(S):

- a. Maximum allowable fan speed is 1200 rpm for all sizes.
- b. Fan performance is based on deductions for wet coil, clean 2 in. filters, and unit casing. See table below for factory-supplied filter pressure drop.
- c. **Bold** indicates field-supplied drive is required.
Plain type indicates standard motor and standard drive.
Underlining indicates a different motor and drive combination other than the standard motor and standard drive combination is required.

Factory-Supplied Pressure Drop — English

UNIT	AIRFLOW (Cfm)	PRESSURE DROP (in. wg)
FAS150	3,750	0.06
	5,000	0.10
	6,250	0.13
FAS180	4,500	0.08
	6,000	0.12
	7,500	0.17
FAS240	6,000	0.12
	8,000	0.19
	10,000	0.26
FAS300	7,500	0.15
	10,000	0.22
	12,500	0.30
FAS336	9,000	0.19
	12,000	0.29
	15,000	0.40

LEGEND

- Bhp** — Brake Horsepower Input to Fan
- ESP** — External Static Pressure

Fan data (cont)

Standard Fan, FAS150-336, 0-300 Pa ESP, 60 Hz — SI^{a,b}

UNIT	AIRFLOW (L/s)	EXTERNAL STATIC PRESSURE (Pa) ^c													
		0		50		100		150		200		250		300	
		r/s	kW	r/s	kW	r/s	kW	r/s	kW	r/s	kW	r/s	kW	r/s	kW
FAS150	1770	6.84	0.32	7.78	0.41	9.46	0.62	10.82	0.83	12.02	1.05	<u>13.13</u>	<u>1.28</u>	<u>14.19</u>	<u>1.53</u>
	2030	7.58	0.46	8.40	0.55	9.98	0.78	11.31	1.03	<u>12.47</u>	<u>1.27</u>	<u>13.52</u>	<u>1.52</u>	<u>14.51</u>	<u>1.78</u>
	2360	8.57	0.69	9.27	0.79	10.68	1.04	11.96	1.31	<u>13.09</u>	<u>1.60</u>	<u>14.11</u>	<u>1.88</u>	<u>15.05</u>	<u>2.17</u>
	2690	9.59	0.99	10.20	1.10	11.44	1.36	<u>12.64</u>	<u>1.66</u>	<u>13.74</u>	<u>1.98</u>	<u>14.74</u>	<u>2.30</u>	<u>15.65</u>	<u>2.63</u>
	2950	10.40	1.28	10.96	1.39	12.09	1.67	<u>13.21</u>	<u>1.98</u>	<u>14.27</u>	<u>2.33</u>	<u>15.25</u>	<u>2.68</u>	<u>16.15</u>	<u>3.03</u>
FAS180	2120	7.28	0.45	8.05	0.54	9.60	0.75	11.00	1.00	<u>12.21</u>	<u>1.26</u>	<u>13.28</u>	<u>1.15</u>	<u>14.27</u>	<u>1.78</u>
	2500	8.32	0.71	8.97	0.80	10.29	1.02	11.59	1.30	<u>12.78</u>	<u>1.59</u>	<u>13.84</u>	<u>1.89</u>	<u>14.80</u>	<u>2.19</u>
	2830	9.25	1.00	9.83	1.10	10.99	1.33	<u>12.16</u>	<u>1.62</u>	<u>13.29</u>	<u>1.93</u>	<u>14.34</u>	<u>2.27</u>	<u>15.30</u>	<u>2.60</u>
	3210	10.33	1.42	10.85	1.54	11.87	1.78	<u>12.90</u>	<u>2.07</u>	<u>13.93</u>	<u>2.40</u>	<u>14.93</u>	<u>2.76</u>	<u>15.87</u>	<u>3.14</u>
FAS240	3540	11.29	1.88	11.77	2.01	<u>12.69</u>	<u>2.27</u>	<u>13.62</u>	<u>2.56</u>	<u>14.56</u>	<u>2.90</u>	<u>15.49</u>	<u>3.27</u>	<u>16.40</u>	<u>3.67</u>
	2830	9.03	0.96	9.62	1.06	10.77	1.28	11.93	1.56	13.08	1.87	14.15	2.20	<u>15.12</u>	<u>2.54</u>
	3300	10.33	1.48	10.87	1.60	11.85	1.85	12.85	2.13	13.85	2.45	<u>14.83</u>	<u>2.80</u>	<u>15.78</u>	<u>3.18</u>
	3780	11.67	2.18	12.13	2.31	13.02	2.58	13.88	2.87	<u>14.75</u>	<u>3.20</u>	<u>15.63</u>	<u>3.56</u>	<u>16.50</u>	<u>3.97</u>
	4250	13.02	3.06	13.43	3.21	14.23	3.51	<u>15.00</u>	<u>3.83</u>	<u>15.77</u>	<u>4.16</u>	<u>16.55</u>	<u>4.53</u>	<u>17.32</u>	<u>4.94</u>
FAS300	4720	14.37	4.15	<u>14.75</u>	<u>4.32</u>	<u>15.48</u>	<u>4.65</u>	<u>16.18</u>	<u>5.00</u>	<u>16.87</u>	<u>5.35</u>	<u>17.57</u>	<u>5.73</u>	<u>18.27</u>	<u>6.14</u>
	3540	7.93	1.04	8.50	1.18	9.65	1.48	10.73	1.79	11.68	2.10	12.53	2.45	13.40	2.95
	4130	9.08	1.60	9.57	1.75	10.55	2.10	11.52	2.45	12.45	2.81	13.28	3.17	<u>14.03</u>	<u>3.55</u>
	4720	10.25	2.33	10.68	2.51	11.53	2.89	12.38	3.29	13.23	3.70	<u>14.05</u>	<u>4.11</u>	<u>14.80</u>	<u>4.51</u>
	5310	11.42	3.26	11.82	3.46	12.57	3.88	13.33	4.32	<u>14.08</u>	<u>4.77</u>	<u>14.85</u>	<u>5.23</u>	<u>15.58</u>	<u>5.70</u>
FAS336	5900	12.60	4.41	12.97	4.64	13.65	5.09	<u>14.33</u>	<u>5.57</u>	<u>15.02</u>	<u>6.07</u>	<u>15.70</u>	<u>6.58</u>	<u>16.38</u>	<u>7.10</u>
	4250	8.98	1.63	9.48	1.78	10.43	2.13	11.38	2.49	12.32	2.86	13.18	3.22	<u>13.95</u>	<u>3.59</u>
	4960	10.33	2.51	10.77	2.70	11.58	3.08	12.40	3.49	13.22	3.91	<u>14.03</u>	<u>4.35</u>	<u>14.80</u>	<u>4.78</u>
	5660	11.68	3.68	12.07	3.89	12.82	4.33	13.52	4.77	<u>14.23</u>	<u>5.25</u>	<u>14.95</u>	<u>5.73</u>	<u>15.67</u>	<u>6.23</u>
	6370	13.05	5.18	13.40	5.42	<u>14.07</u>	<u>5.90</u>	<u>14.72</u>	<u>6.39</u>	<u>15.33</u>	<u>6.91</u>	<u>15.97</u>	<u>7.43</u>	<u>16.60</u>	<u>7.99</u>
7080	<u>14.42</u>	<u>7.05</u>	<u>14.73</u>	<u>7.32</u>	<u>15.35</u>	<u>7.84</u>	<u>15.93</u>	<u>8.38</u>	<u>16.52</u>	<u>8.93</u>	<u>17.08</u>	<u>9.51</u>	<u>17.65</u>	<u>10.10</u>	

NOTE(S):

- a. Maximum allowable fan speed is 20 r/s for all sizes.
- b. Fan performance is based on deductions for wet coil, clean 51 mm filters, and unit casing. See table below for factory-supplied filter pressure drop.
- c. **Bold** indicates field-supplied drive is required.
Plain type indicates standard motor and standard drive.
Underlining indicates a different motor and drive combination other than the standard motor and standard drive combination is required.

Factory-Supplied Pressure Drop — SI

LEGEND

ESP — External Static Pressure

UNIT	AIRFLOW (L/s)	PRESSURE DROP (Pa)
FAS150	1750	15
	2350	24
	3950	33
FAS180	2100	20
	2800	30
	3500	42
FAS240	2900	32
	3800	47
	4700	64
FAS300	3500	36
	4700	55
	5900	76
FAS336	4250	47
	5650	71
	7050	98

Fan data (cont)

Standard Fan, FAS150-336, 350-600 Pa ESP, 60 Hz — SI^{a,b}

UNIT	AIRFLOW (L/s)	EXTERNAL STATIC PRESSURE (Pa) ^c											
		350		400		450		500		550		600	
		r/s	kW	r/s	kW	r/s	kW	r/s	kW	r/s	kW	r/s	kW
FAS150	1770	<u>15.21</u>	1.78	<u>16.19</u>	<u>2.06</u>	<u>17.13</u>	<u>2.34</u>	<u>18.04</u>	<u>2.64</u>	18.91	2.94	19.75	3.25
	2030	<u>15.46</u>	<u>2.05</u>	<u>16.37</u>	<u>2.33</u>	<u>17.26</u>	<u>2.63</u>	<u>18.12</u>	<u>2.94</u>	18.96	3.26	19.78	3.59
	2360	<u>15.94</u>	2.46	<u>16.78</u>	<u>2.77</u>	<u>17.60</u>	3.08	18.40	3.40	19.18	3.73	19.94	4.07
	2690	<u>16.51</u>	2.95	<u>17.32</u>	<u>3.28</u>	<u>18.09</u>	3.62	18.84	3.96	19.57	4.31	—	—
	2950	<u>16.99</u>	<u>3.39</u>	<u>17.78</u>	<u>3.74</u>	18.54	4.10	19.26	4.47	19.96	4.84	—	—
FAS180	2120	<u>15.21</u>	<u>2.05</u>	<u>16.11</u>	<u>2.33</u>	<u>16.98</u>	<u>2.62</u>	<u>17.83</u>	<u>2.93</u>	<u>18.66</u>	<u>3.24</u>	<u>19.47</u>	<u>3.57</u>
	2500	<u>15.93</u>	<u>2.49</u>	<u>16.54</u>	<u>2.80</u>	<u>17.35</u>	<u>3.12</u>	<u>18.14</u>	<u>3.44</u>	<u>18.90</u>	<u>3.77</u>	19.64	4.11
	2830	<u>16.18</u>	<u>2.94</u>	<u>17.01</u>	<u>3.28</u>	<u>17.79</u>	<u>3.63</u>	<u>18.54</u>	<u>3.97</u>	<u>19.27</u>	<u>4.33</u>	19.97	4.69
	3210	<u>16.75</u>	<u>3.52</u>	<u>17.57</u>	<u>3.90</u>	<u>18.34</u>	<u>4.29</u>	<u>19.08</u>	<u>4.67</u>	19.78	5.06	—	—
	3540	<u>17.26</u>	4.09	<u>18.07</u>	4.50	<u>18.84</u>	4.93	19.57	5.35	—	—	—	—
FAS240	2830	<u>16.02</u>	<u>2.88</u>	<u>16.85</u>	<u>3.21</u>	<u>17.63</u>	<u>3.56</u>	<u>18.40</u>	<u>3.91</u>	<u>19.12</u>	<u>4.26</u>	—	—
	3300	<u>16.67</u>	<u>3.57</u>	<u>17.50</u>	<u>3.97</u>	<u>18.28</u>	<u>4.36</u>	<u>19.03</u>	<u>4.76</u>	<u>19.73</u>	<u>5.15</u>	—	—
	3780	<u>17.35</u>	4.38	<u>18.17</u>	<u>4.82</u>	<u>18.95</u>	<u>5.27</u>	<u>19.68</u>	<u>5.72</u>	—	—	—	—
	4250	<u>18.10</u>	<u>5.38</u>	<u>18.88</u>	<u>5.83</u>	<u>19.63</u>	<u>6.32</u>	—	—	—	—	—	—
	4720	<u>18.97</u>	6.58	<u>19.67</u>	<u>7.05</u>	—	—	—	—	—	—	—	—
FAS300	3540	<u>14.57</u>	3.97	<u>14.95</u>	4.41	<u>15.67</u>	<u>5.07</u>	<u>16.50</u>	<u>5.59</u>	—	—	—	—
	4130	<u>14.77</u>	<u>4.00</u>	<u>15.50</u>	<u>4.71</u>	<u>16.37</u>	<u>5.46</u>	<u>17.00</u>	<u>6.04</u>	—	—	—	—
	4720	<u>15.50</u>	<u>4.92</u>	<u>16.15</u>	<u>5.22</u>	<u>16.78</u>	<u>5.88</u>	<u>17.42</u>	<u>6.50</u>	—	—	—	—
	5310	<u>16.27</u>	<u>6.15</u>	<u>16.90</u>	<u>6.61</u>	<u>17.52</u>	<u>7.08</u>	18.10	7.58	—	—	—	—
	5900	<u>17.05</u>	<u>7.61</u>	<u>17.68</u>	<u>8.11</u>	18.28	8.62	—	—	—	—	—	—
FAS336	4250	<u>14.68</u>	4.00	<u>15.38</u>	4.50	<u>16.12</u>	<u>5.14</u>	<u>17.00</u>	<u>6.15</u>	—	—	—	—
	4960	<u>15.50</u>	5.20	<u>16.17</u>	<u>5.63</u>	<u>16.80</u>	<u>6.09</u>	<u>17.42</u>	<u>6.61</u>	—	—	—	—
	5660	<u>16.35</u>	<u>6.73</u>	<u>17.02</u>	<u>7.21</u>	—	—	—	—	—	—	—	—
	6370	<u>17.25</u>	<u>8.54</u>	—	—	—	—	—	—	—	—	—	—
	7080	—	—	—	—	—	—	—	—	—	—	—	—

NOTE(S):

- a. Maximum allowable fan speed is 20 r/s for all sizes.
- b. Fan performance is based on deductions for wet coil, clean 51 mm filters, and unit casing. See table below for factory-supplied filter pressure drop.
- c. **Bold** indicates field-supplied drive is required.
Plain type indicates standard motor and standard drive.
Underlining indicates a different motor and drive combination other than the standard motor and standard drive combination is required.

Factory-Supplied Pressure Drop — SI

LEGEND

UNIT	AIRFLOW (L/s)	PRESSURE DROP (Pa)
FAS150	1750	15
	2350	24
	3950	33
FAS180	2100	20
	2800	30
	3500	42
FAS240	2900	32
	3800	47
	4700	64
FAS300	3500	36
	4700	55
	5900	76
FAS336	4250	47
	5650	71
	7050	98

ESP — External Static Pressure

Electrical data

FAX072-120, FAS150-336, Electrical Data, Two-Speed Motors

UNIT ^{a,b}	NOMINAL V-PH-Hz ^c	IFM TYPE	UNIT VOLTAGE LIMITS		FAN MOTOR			POWER SUPPLY ^d	
			Min.	Max.	Hp	kW	FLA ^e	Minimum Circuit Amps (MCA)	Maximum Overcurrent Protection (MOCP)
FAX072	208/230-3-60	MED	187	253	2.4	1.76	6.4/5.8	8/8	15/15
		HIGH	187	253	3.0	2.24	7.5/6.7	10/9	15/15
	460-3-60	MED	414	506	2.4	1.76	3.0	4	15
		HIGH	414	506	3.0	2.24	3.5	5	15
	575-3-60	MED	518	632	2.4	1.76	2.5	4	15
		HIGH	518	632	3.0	2.24	3.0	4	15
FAX091	208/230-3-60	MED	187	253	2.4	1.76	6.4/5.8	8/8	15/15
		HIGH	187	253	3.0	2.24	7.5/6.7	10/9	15/15
	460-3-60	MED	414	506	2.4	1.76	3.0	4	15
		HIGH	414	506	3.0	2.24	3.5	5	15
	575-3-60	MED	518	632	2.4	1.76	2.5	4	15
		HIGH	518	632	3.0	2.24	3.0	4	15
FAX120	208/230-3-60	MED	187	253	2.4	1.76	6.4/5.8	8/8	15/15
		HIGH	187	253	3.0	2.24	7.5/6.7	10/9	15/15
	460-3-60	MED	414	506	2.4	1.76	3.0	4	15
		HIGH	414	506	3.0	2.24	3.5	5	15
	575-3-60	MED	518	632	2.4	1.76	2.5	4	15
		HIGH	518	632	3.0	2.24	3.0	4	15
FAS150	208/230-3-60	STD	187	253	2.9	2.16	8.6	11	15
		HIGH	187	253	3.7	2.76	10.8	14	20
	460-3-60	STD	414	506	2.9	2.16	3.8	5	15
		HIGH	414	506	3.7	2.76	4.9	7	15
	575-3-60	STD	518	632	3.7	2.76	4.5	6	15
		HIGH	518	632	5.0	3.73	8.0	10	15
FAS180	208/230-3-60	STD	187	253	3.7	2.76	10.8	14	20
		HIGH	187	253	5.0	3.73	18.0	23	40
	460-3-60	STD	414	506	3.7	2.76	4.9	7	15
		HIGH	414	506	5.0	3.73	9.1	12	20
	575-3-60	STD	518	632	3.7	2.76	4.5	6	15
		HIGH	518	632	5.0	3.73	8.0	10	15
FAS240	208/230-3-60	STD	187	253	5.0	3.73	18.0	23	40
		HIGH	187	253	7.5	5.60	23.5	30	50
	460-3-60	STD	414	506	5.0	3.73	9.1	12	20
		HIGH	414	506	7.5	5.60	15.0	19	30
	575-3-60	STD	518	632	5.0	3.73	8.0	10	15
		HIGH	518	632	7.5	5.60	10.0	13	20

Electrical data (cont)

FAX072-120, FAS150-336, Electrical Data, Two-Speed Motors (cont)

UNIT ^{a,b}	NOMINAL V-PH-Hz ^c	IFM TYPE	UNIT VOLTAGE LIMITS		FAN MOTOR			POWER SUPPLY ^d	
			Min.	Max.	Hp	kW	FLA ^e	Minimum Circuit Amps (MCA)	Maximum Overcurrent Protection (MOCP)
FAS300	208/230-3-60	STD	187	253	7.5	5.60	23.5	30	50
		HIGH	187	253	10.0	7.46	32.0	40	70
	460-3-60	STD	414	506	7.5	5.60	15.0	19	30
		HIGH	414	506	10.0	7.46	16.0	20	35
	575-3-60	STD	518	632	7.5	5.60	10.0	13	20
		HIGH	518	632	10.0	7.46	13.0	17	25
FAS336	208/230-3-60	STD	187	253	10.0	7.46	32.0	40	70
		HIGH	187	253	10.0	7.46	32.0	40	70
	460-3-60	STD	414	506	10.0	7.46	16.0	20	35
		HIGH	414	506	10.0	7.46	16.0	20	35
	575-3-60	STD	518	632	10.0	7.46	13.0	17	25
		HIGH	518	632	10.0	7.46	13.0	17	25

NOTE(S):

- Unbalanced 3-Phase Supply Voltage: Never operate a motor where a phase imbalance in supply voltage is greater than 2%. Use the formula in the example below to determine the percentage of voltage imbalance.
- Installation with Accessory Electric Heaters: Size the Field Power Wiring between the heater TB1 and the FAS indoor fan motor per NEC Article 430-28 (1) or (2) (depends on length of conduit between heater enclosure and FAX/FAS power entry location). Install wires in field-installed conduit.
- Motors are designed for satisfactory operation within 10% of normal voltage shown. Voltages should not exceed the limits shown in the Voltage Limits column.
- Minimum circuit amps (MCA) and MOCP values are calculated in accordance with The NEC, Article 440.
- Motor FLA values are established in accordance with Underwriters' Laboratories (UL), Standard 1995.

$$\% \text{ Voltage Imbalance} = 100 \times \frac{\text{max voltage deviation from average voltage}}{\text{average voltage}}$$

Example: Supply voltage is 230-3-60

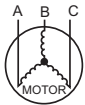

AB = 224 v
BC = 231 v
AC = 226 v

$$\text{Average Voltage} = \frac{(224 + 231 + 226)}{3} = \frac{681}{3} = 227$$

Determine maximum deviation from average voltage.

(AB) 227-224 = 3 v

(BC) 231-227 = 4 v

(AC) 227-226 = 1 v

Maximum deviation is 4 v.

Determine percent of voltage imbalance.

$$\% \text{ Voltage Imbalance} = 100 \times \frac{4}{227} = 1.78\%$$

This amount of phase imbalance is satisfactory as it is below the maximum allowable 2%.

IMPORTANT: If the supply voltage phase imbalance is more than 2%, contact your local electric utility company immediately.

LEGEND

- FLA** — Full Load Amps
- MCA** — Minimum Circuit Amps
- MOCP** — Maximum Overcurrent Protection

Electric data (cont)

Legend and Notes for Electrical Heater Data tables, pages 42-49.

LEGEND

- FLA** — Full Load Amps
MCA — Minimum Circuit Amps
MOCP — Maximum Overcurrent Protection (Amps)

NOTES:

1. Electrical resistance heaters are rated at 240v, 480v, 575v. To determine heater capacity (kW) at unit nameplate multiply the 240v, 480v, or 575v capacity (kW) by the factor shown in the table below for the unit voltage.
2. The following equation converts kW of heat energy to Btuh: kW x 3412 = Btuh.
3. Heater contactor coils are 24v and require 8va holding current.
4. Electric heaters are tested and UL approved at maximum total external static pressure of 1.9 in. wg.

HEATER RATING VOLTAGE	ACTUAL HEATER VOLTAGE AT SITE										
	200	208	230	240	400	440	460	480	550	575	600
240	0.694	0.751	0.918	1	—	—	—	—	—	—	—
480	—	—	—	—	0.694	0.84	0.918	1	—	—	—
575	—	—	—	—	—	—	—	—	0.915	1	1.089

FAX072-120, 60 Hz Electrical Heater Data

UNIT	NOMINAL VOLTS	IFM TYPE	UNIT VOLTAGE		FAN MOTOR (QTY 1)			ELECTRIC HEATER(S)						POWER SUPPLY ^a			
			Range		hp	kW	FLA	CAELHEAT ****00	Heater Voltage	Nom. Cap. (kW)	Actual Capacity (kW)			FLA (Full Load Amps)	MCA (Minimum Ckt Amps)	MOCP (Maximum Overcurrent Protection)	
			Min	Max							Stage 1	Stage 2	Total				
FAX072	208/230	Med	187	253	2.4	1.76	6.4/5.8	050A	208/240	5	3.8/5.0	—	3.8/5.0	10.4/12.0	21.0/22.3	25/25	
			187	253	2.4	1.76	6.4/5.8	052A	208/240	10	7.5/10.0	—	7.5/10.0	20.8/24.1	34.0/37.4	35/40	
			187	253	2.4	1.76	6.4/5.8	055A	208/240	15	11.3/15.0	—	11.3/15.0	31.3/36.1	47.1/52.4	50/60	
			187	253	2.4	1.76	6.4/5.8	058A	208/240	25	11.3/15.0	7.5/10.0	18.8/25.0	52.1/60.1	73.1/82.4	80/90	
		High	187	253	3.0	2.24	7.5/6.7	050A	208/240	5	3.8/5.0	—	3.8/5.0	10.4/12.0	22.4/23.4	25/25	
			187	253	3.0	2.24	7.5/6.7	052A	208/240	10	7.5/10.0	—	7.5/10.0	20.8/24.1	35.4/38.5	40/40	
			187	253	3.0	2.24	7.5/6.7	055A	208/240	15	11.3/15.0	—	11.3/15.0	31.3/36.1	48.5/53.5	50/60	
			187	253	3.0	2.24	7.5/6.7	058A	208/240	25	11.3/15.0	7.5/10.0	18.8/25.0	52.1/60.1	74.5/83.5	80/90	
	460	Med	414	506	2.4	1.76	3.0	051A	480	5	5.0	—	5.0	6.0	11.3	15	
			414	506	2.4	1.76	3.0	053A	480	10	10.0	—	10.0	12.0	18.8	20	
			414	506	2.4	1.76	3.0	056A	480	15	15.0	—	15.0	18.0	26.3	30	
			414	506	2.4	1.76	3.0	059A	480	25	15.0	10.0	25.0	30.1	41.4	50	
		High	414	506	3.0	2.24	3.5	051A	480	5	5.0	—	5.0	6.0	11.9	15	
			414	506	3.0	2.24	3.5	053A	480	10	10.0	—	10.0	12.0	19.4	20	
			414	506	3.0	2.24	3.5	056A	480	15	15.0	—	15.0	18.0	26.9	30	
			414	506	3.0	2.24	3.5	059A	480	25	15.0	10.0	25.0	30.1	42.0	50	
	575	Med	518	632	2.4	1.76	2.5	064A	575	5	5.0	—	5.0	4.8	9.1	15	
			518	632	2.4	1.76	2.5	054A	575	10	10.0	—	10.0	9.6	15.1	20	
			518	632	2.4	1.76	2.5	057A	575	15	15.0	—	15.0	14.4	21.1	25	
			518	632	2.4	1.76	2.5	060A	575	25	15.0	10.0	25.0	24.1	33.3	35	
		High	518	632	3.0	2.24	3.0	064A	575	5	5.0	—	5.0	4.8	9.8	15	
			518	632	3.0	2.24	3.0	054A	575	10	10.0	—	10.0	9.6	15.8	20	
			518	632	3.0	2.24	3.0	057A	575	15	15.0	—	15.0	14.4	21.8	25	
			518	632	3.0	2.24	3.0	060A	575	25	15.0	10.0	25.0	24.1	33.9	35	
	FAX091	208/230	Med	187	253	2.4	1.76	6.4/5.8	050A	208/240	5	3.8/5.0	—	3.8/5.0	10.4/12.0	21.0/22.3	25/25
				187	253	2.4	1.76	6.4/5.8	052A	208/240	10	7.5/10.0	—	7.5/10.0	20.8/24.1	34.0/37.4	35/40
				187	253	2.4	1.76	6.4/5.8	055A	208/240	15	11.3/15.0	—	11.3/15.0	31.3/36.1	47.1/52.4	50/60
				187	253	2.4	1.76	6.4/5.8	058A	208/240	25	11.3/15.0	7.5/10.0	18.8/25.0	52.1/60.1	73.1/82.4	80/90
High			187	253	2.4	1.76	6.4/5.8	061A	208/240	32	12.0/16.0	12.0/16.0	24.0/32.0	66.7/77.0	91.4/103.5	100/110	
			187	253	3.0	2.24	7.5/6.7	050A	208/240	5	3.8/5.0	—	3.8/5.0	10.4/12.0	22.4/23.4	25/25	
			187	253	3.0	2.24	7.5/6.7	052A	208/240	10	7.5/10.0	—	7.5/10.0	20.8/24.1	35.4/38.5	40/40	
			187	253	3.0	2.24	7.5/6.7	055A	208/240	15	11.3/15.0	—	11.3/15.0	31.3/36.1	48.5/53.5	50/60	
208/230		High	187	253	3.0	2.24	7.5/6.7	058A	208/240	25	11.3/15.0	7.5/10.0	18.8/25.0	52.1/60.1	74.5/83.5	80/90	
			187	253	3.0	2.24	7.5/6.7	061A	208/240	32	12.0/16.0	12.0/16.0	24.0/32.0	66.7/77.0	92.8/104.6	100/110	

Specifications subject to change without notice.

FAX072-120, 60 Hz Electrical Heater Data (cont)

Electrical data (cont)

UNIT	NOMINAL VOLTS	IFM TYPE	UNIT VOLTAGE		FAN MOTOR (QTY 1)			ELECTRIC HEATER(S)						POWER SUPPLY ^a		
			Range		hp	kW	FLA	CAELHEAT ****00	Heater Voltage	Nom. Cap. (kW)	Actual Capacity (kW)			FLA (Full Load Amps)	MCA (Minimum Ckt Amps)	MOCP (Maximum Overcurrent Protection)
			Min	Max							Stage 1	Stage 2	Total			
FAX091 (cont)	460	Med	414	506	2.4	1.76	3.0	051A	480	5	5.0	—	5.0	6.0	11.3	15
			414	506	2.4	1.76	3.0	053A	480	10	10.0	—	10.0	12.0	18.8	20
			414	506	2.4	1.76	3.0	056A	480	15	15.0	—	15.0	18.0	26.3	30
			414	506	2.4	1.76	3.0	059A	480	25	15.0	10.0	25.0	30.1	41.4	50
			414	506	2.4	1.76	3.0	062A	480	35	20.0	15.0	35.0	42.1	56.4	60
		High	414	506	3.0	2.24	3.5	051A	480	5	5.0	—	5.0	6.0	11.9	15
			414	506	3.0	2.24	3.5	053A	480	10	10.0	—	10.0	12.0	19.4	20
			414	506	3.0	2.24	3.5	056A	480	15	15.0	—	15.0	18.0	26.9	30
			414	506	3.0	2.24	3.5	059A	480	25	15.0	10.0	25.0	30.1	42.0	50
	575	Med	414	506	3.0	2.24	3.5	062A	480	35	20.0	15.0	35.0	42.1	57.0	60
			518	632	2.4	1.76	2.5	064A	575	5	5.0	—	5.0	4.8	9.1	15
			518	632	2.4	1.76	2.5	054A	575	10	10.0	—	10.0	9.6	15.1	20
			518	632	2.4	1.76	2.5	057A	575	15	15.0	—	15.0	14.4	21.1	25
			518	632	2.4	1.76	2.5	060A	575	25	15.0	10.0	25.0	24.1	33.3	35
		High	518	632	2.4	1.76	2.5	063A	575	35	20.0	15.0	35.0	33.7	45.3	50
			518	632	3.0	2.24	3.0	064A	575	5	5.0	—	5.0	4.8	9.8	15
			518	632	3.0	2.24	3.0	054A	575	10	10.0	—	10.0	9.6	15.8	20
			518	632	3.0	2.24	3.0	057A	575	15	15.0	—	15.0	14.4	21.8	25
FAX120	208/230	Med	518	632	3.0	2.24	3.0	060A	575	25	15.0	10.0	25.0	24.1	33.9	35
			518	632	3.0	2.24	3.0	063A	575	35	20.0	15.0	35.0	33.7	45.9	50
			187	253	2.4	1.76	6.4/5.8	050A	208/240	5	3.8/5.0	—	3.8/5.0	10.4/12.0	21.0/22.3	25/25
			187	253	2.4	1.76	6.4/5.8	052A	208/240	10	7.5/10.0	—	7.5/10.0	20.8/24.1	34.0/37.4	35/40
			187	253	2.4	1.76	6.4/5.8	055A	208/240	15	11.3/15.0	—	11.3/15.0	31.3/36.1	47.1/52.4	50/60
		High	187	253	2.4	1.76	6.4/5.8	058A	208/240	25	11.3/15.0	7.5/10.0	18.8/25.0	52.1/60.1	73.1/82.4	80/90
			187	253	2.4	1.76	6.4/5.8	061A	208/240	32	12.0/16.0	12.0/16.0	24.0/32.0	66.7/77.0	91.4/103.5	100/110
			187	253	3.0	2.24	7.5/6.7	050A	208/240	5	3.8/5.0	—	3.8/5.0	10.4/12.0	22.4/23.4	25/25
			187	253	3.0	2.24	7.5/6.7	052A	208/240	10	7.5/10.0	—	7.5/10.0	20.8/24.1	35.4/38.5	40/40
460	Med	187	253	3.0	2.24	7.5/6.7	055A	208/240	15	11.3/15.0	—	11.3/15.0	31.3/36.1	48.5/53.5	50/60	
		187	253	3.0	2.24	7.5/6.7	058A	208/240	25	11.3/15.0	7.5/10.0	18.8/25.0	52.1/60.1	74.5/83.5	80/90	
		187	253	3.0	2.24	7.5/6.7	061A	208/240	32	12.0/16.0	12.0/16.0	24.0/32.0	66.7/77.0	92.8/104.6	100/110	
		414	506	2.4	1.76	3.0	051A	480	5	5.0	—	5.0	6.0	11.3	15	
		414	506	2.4	1.76	3.0	053A	480	10	10.0	—	10.0	12.0	18.8	20	
	High	414	506	2.4	1.76	3.0	056A	480	15	15.0	—	15.0	18.0	26.3	30	
		414	506	2.4	1.76	3.0	059A	480	25	15.0	10.0	25.0	30.1	41.4	50	
		414	506	2.4	1.76	3.0	062A	480	35	20.0	15.0	35.0	42.1	56.4	60	
		414	506	3.0	2.24	3.5	051A	480	5	5.0	—	5.0	6.0	11.9	15	
460	High	414	506	3.0	2.24	3.5	053A	480	10	10.0	—	10.0	12.0	19.4	20	
		414	506	3.0	2.24	3.5	056A	480	15	15.0	—	15.0	18.0	26.9	30	
		414	506	3.0	2.24	3.5	059A	480	25	15.0	10.0	25.0	30.1	42.0	50	
		414	506	3.0	2.24	3.5	062A	480	35	20.0	15.0	35.0	42.1	57.0	60	

FAX072-120, 60 Hz Electrical Heater Data (cont)

UNIT	NOMINAL VOLTS	IFM TYPE	UNIT VOLTAGE		FAN MOTOR (QTY 1)			ELECTRIC HEATER(S)						POWER SUPPLY ^a		
			Range		hp	kW	FLA	CAELHEAT ****00	Heater Voltage	Nom. Cap. (kW)	Actual Capacity (kW)			FLA (Full Load Amps)	MCA (Minimum Ckt Amps)	MOCP (Maximum Overcurrent Protection)
			Min	Max							Stage 1	Stage 2	Total			
FAX120 (cont)	575	Med	518	632	2.4	1.76	2.5	064A	575	5	5.0	—	5.0	4.8	9.1	15
			518	632	2.4	1.76	2.5	054A	575	10	10.0	—	10.0	9.6	15.1	20
			518	632	2.4	1.76	2.5	057A	575	15	15.0	—	15.0	14.4	21.1	25
			518	632	2.4	1.76	2.5	060A	575	25	15.0	10.0	25.0	24.1	33.3	35
			518	632	2.4	1.76	2.5	063A	575	35	20.0	15.0	35.0	33.7	45.3	50
		High	518	632	3.0	2.24	3.0	064A	575	5	5.0	—	5.0	4.8	9.8	15
			518	632	3.0	2.24	3.0	054A	575	10	10.0	—	10.0	9.6	15.8	20
			518	632	3.0	2.24	3.0	057A	575	15	15.0	—	15.0	14.4	21.8	25
			518	632	3.0	2.24	3.0	060A	575	25	15.0	10.0	25.0	24.1	33.9	35
			518	632	3.0	2.24	3.0	063A	575	35	20.0	15.0	35.0	33.7	45.9	50

NOTE(S):

a. MCA and MOCP Values shown are for single-point connection of electric heat accessory and air handler.

FAS150-336, 60 Hz Electrical Heater Data

UNIT	NOM. VOLTS	IFM TYPE	UNIT VOLTAGE		FAN MOTOR (QTY 1)			ELECTRIC HEATER(S)						POWER SUPPLY ^a			
			Range		hp	kW	FLA	CAEL HEAT ****00	Heater Voltage	Nom. Cap. (kW)	Actual Capacity (kW)			FLA (Full Load Amps)	MCA (Minimum Ckt Amps)	MOCP (Maximum Overcurrent Protection)	
			Min	Max							Stage 1	Stage 2	Total				
FAS150	208/230	STD	187	253	2.9	2.16	8.6	016A	208/240	10	7.5/10	—	7.5/10	20.8/24.1	36.8/40.9	40/50	
			187	253	2.9	2.16	8.6	019A	208/240	20	15/20	—	15/20	41.7/48.1	62.9/70.9	70/80	
			187	253	2.9	2.16	8.6	022A	208/240	30	15/20	7.5/10	22.5/30	62.5/72.2	88.9/101	90/110	
			187	253	2.9	2.16	8.6	025A	208/240	50	22.6/30	15/20	37.6/50	104.2/120.3	141/161.1	150/175	
		HIGH	187	253	3.7	2.76	10.8	016A	208/240	10	7.5/10	—	7.5/10	20.8/24.1	39.5/43.6	40/50	
			187	253	3.7	2.76	10.8	019A	208/240	20	15/20	—	15/20	41.7/48.1	65.6/73.6	70/80	
			187	253	3.7	2.76	10.8	022A	208/240	30	15/20	7.5/10	22.5/30	62.5/72.2	91.6/103.8	100/110	
			187	253	3.7	2.76	10.8	025A	208/240	50	22.6/30	15/20	37.6/50	104.2/120.3	143.8/163.9	150/175	
		460	STD	414	506	2.9	2.16	3.8	017A	480	10	10	—	10	12	19.8	20
				414	506	2.9	2.16	3.8	020A	480	20	20	—	20	23.9	34.6	35
				414	506	2.9	2.16	3.8	023A	480	30	20	10	30	36.1	49.9	50
				414	506	2.9	2.16	3.8	026A	480	50	30	20	50	60.1	79.9	80
	HIGH		414	506	3.7	2.76	4.9	017A	480	10	10	—	10	12	21.1	25	
			414	506	3.7	2.76	4.9	020A	480	20	20	—	20	23.9	36	40	
			414	506	3.7	2.76	4.9	023A	480	30	20	10	30	36.1	51.3	60	
			414	506	3.7	2.76	4.9	026A	480	50	30	20	50	60.1	81.3	90	
	575	STD	518	632	3.7	2.76	4.5	018A	575	10	10	—	10	10	18.1	20	
			518	632	3.7	2.76	4.5	021A	575	20	20	—	20	20.1	30.8	35	
			518	632	3.7	2.76	4.5	024A	575	30	20	10	30	30.1	43.3	50	
			518	632	3.7	2.76	4.5	027A	575	50	30	20	50	50.2	68.4	70	
		HIGH	518	632	5.0	3.73	8.0	018A	575	10	10	—	10	10	22.5	25	
			518	632	5.0	3.73	8.0	021A	575	20	20	—	20	20.1	35.1	40	
			518	632	5.0	3.73	8.0	024A	575	30	20	10	30	30.1	47.6	50	
			518	632	5.0	3.73	8.0	027A	575	50	30	20	50	50.2	72.8	80	

FAS150-336, 60 Hz Electrical Heater Data (cont)

UNIT	NOM. VOLTS	IFM TYPE	UNIT VOLTAGE		FAN MOTOR (QTY 1)			ELECTRIC HEATER(S)						POWER SUPPLY ^a		
			Range		hp	kW	FLA	CAEL HEAT ****00	Heater Voltage	Nom. Cap. (kW)	Actual Capacity (kW)			FLA (Full Load Amps)	MCA (Minimum Ckt Amps)	MOCP (Maximum Overcurrent Protection)
			Min	Max							Stage 1	Stage 2	Total			
FAS180	208/230	STD	187	253	3.7	2.76	10.8	016A	208/240	10	7.5/10	—	7.5/10	20.8/24.1	39.5/43.6	40/50
			187	253	3.7	2.76	10.8	019A	208/240	20	15/20	—	15/20	41.7/48.1	65.6/73.6	70/80
			187	253	3.7	2.76	10.8	022A	208/240	30	15/20	7.5/10	22.5/30	62.5/72.2	91.6/103.8	100/110
			187	253	3.7	2.76	10.8	025A	208/240	50	22.6/30	15/20	37.6/50	104.2/120.3	143.8/163.9	150/175
		HIGH	187	253	5.0	3.73	18.0	016A	208/240	10	7.5/10	—	7.5/10	20.8/24.1	48.5/52.6	50/60
			187	253	5.0	3.73	18.0	019A	208/240	20	15/20	—	15/20	41.7/48.1	74.6/82.6	80/90
			187	253	5.0	3.73	18.0	022A	208/240	30	15/20	7.5/10	22.5/30	62.5/72.2	100.6/112.8	110/125
			187	253	5.0	3.73	18.0	025A	208/240	50	22.6/30	15/20	37.6/50	104.2/120.3	152.8/172.9	175/175
	460	STD	414	506	3.7	2.76	4.9	017A	480	10	10	—	10	12	21.1	25
			414	506	3.7	2.76	4.9	020A	480	20	20	—	20	23.9	36	40
			414	506	3.7	2.76	4.9	023A	480	30	20	10	30	36.1	51.3	60
			414	506	3.7	2.76	4.9	026A	480	50	30	20	50	60.1	81.3	90
		HIGH	414	506	5.0	3.73	9.1	017A	480	10	10	—	10	12	26.4	30
			414	506	5.0	3.73	9.1	020A	480	20	20	—	20	23.9	41.3	50
			414	506	5.0	3.73	9.1	023A	480	30	20	10	30	36.1	56.5	60
			414	506	5.0	3.73	9.1	026A	480	50	30	20	50	60.1	86.5	90
	575	STD	518	632	3.7	2.76	4.5	018A	575	10	10	—	10	10	18.1	20
			518	632	3.7	2.76	4.5	021A	575	20	20	—	20	20.1	30.8	35
			518	632	3.7	2.76	4.5	024A	575	30	20	10	30	30.1	43.3	50
			518	632	3.7	2.76	4.5	027A	575	50	30	20	50	50.2	68.4	70
		HIGH	518	632	5.0	3.73	8.0	018A	575	10	10	—	10	10	22.5	25
			518	632	5.0	3.73	8.0	021A	575	20	20	—	20	20.1	35.1	40
			518	632	5.0	3.73	8.0	024A	575	30	20	10	30	30.1	47.6	50
			518	632	5.0	3.73	8.0	027A	575	50	30	20	50	50.2	72.8	80

FAS150-336, 60 Hz Electrical Heater Data (cont)

Electrical data (cont)

UNIT	NOM. VOLTS	IFM TYPE	UNIT VOLTAGE		FAN MOTOR (QTY 1)			ELECTRIC HEATER(S)						POWER SUPPLY ^a		
			Range		hp	kW	FLA	CAEL HEAT ****00	Heater Voltage	Nom. Cap. (kW)	Actual Capacity (kW)			FLA (Full Load Amps)	MCA (Minimum Ckt Amps)	MOCP (Maximum Overcurrent Protection)
			Min	Max							Stage 1	Stage 2	Total			
FAS240	208/230	STD	187	253	5.0	3.73	18.0	016A	208/240	10	7.5/10	—	7.5/10	20.8/24.1	48.5/52.6	50/60
			187	253	5.0	3.73	18.0	019A	208/240	20	15/20	—	15/20	41.7/48.1	74.6/82.6	80/90
			187	253	5.0	3.73	18.0	022A	208/240	30	15/20	7.5/10	22.5/30	62.5/72.2	100.6/112.8	110/125
			187	253	5.0	3.73	18.0	025A	208/240	50	22.6/30	15/20	37.6/50	104.2/120.3	152.8/172.9	175/175
		HIGH	187	253	7.5	5.60	23.5	016A	208/240	10	7.5/10	—	7.5/10	20.8/24.1	55.4/59.5	60/60
			187	253	7.5	5.60	23.5	019A	208/240	20	15/20	—	15/20	41.7/48.1	81.5/89.5	90/90
			187	253	7.5	5.60	23.5	022A	208/240	30	15/20	7.5/10	22.5/30	62.5/72.2	107.5/119.6	110/125
			187	253	7.5	5.60	23.5	025A	208/240	50	22.6/30	15/20	37.6/50	104.2/120.3	159.6/179.8	175/200
	460	STD	414	506	5.0	3.73	9.1	017A	480	10	10	—	10	12	26.4	30
			414	506	5.0	3.73	9.1	020A	480	20	20	—	20	23.9	41.3	50
			414	506	5.0	3.73	9.1	023A	480	30	20	10	30	36.1	56.5	60
			414	506	5.0	3.73	9.1	026A	480	50	30	20	50	60.1	86.5	90
		HIGH	414	506	7.5	5.60	15.0	017A	480	10	10	—	10	12	33.8	35
			414	506	7.5	5.60	15.0	020A	480	20	20	—	20	23.9	48.6	50
			414	506	7.5	5.60	15.0	023A	480	30	20	10	30	36.1	63.9	70
			414	506	7.5	5.60	15.0	026A	480	50	30	20	50	60.1	93.9	100
	575	STD	518	632	5.0	3.73	8.0	018A	575	10	10	—	10	10	22.5	25
			518	632	5.0	3.73	8.0	021A	575	20	20	—	20	20.1	35.1	40
			518	632	5.0	3.73	8.0	024A	575	30	20	10	30	30.1	47.6	50
			518	632	5.0	3.73	8.0	027A	575	50	30	20	50	50.2	72.8	80
		HIGH	518	632	7.5	5.60	10.0	018A	575	10	10	—	10	10	25	25
			518	632	7.5	5.60	10.0	021A	575	20	20	—	20	20.1	37.6	40
			518	632	7.5	5.60	10.0	024A	575	30	20	10	30	30.1	50.1	60
			518	632	7.5	5.60	10.0	027A	575	50	30	20	50	50.2	75.3	80

FAS150-336, 60 Hz Electrical Heater Data (cont)

UNIT	NOM. VOLTS	IFM TYPE	UNIT VOLTAGE		FAN MOTOR (QTY 1)			ELECTRIC HEATER(S)						POWER SUPPLY ^a		
			Range		hp	kW	FLA	CAEL HEAT ****00	Heater Voltage	Nom. Cap. (kW)	Actual Capacity (kW)			FLA (Full Load Amps)	MCA (Minimum Ckt Amps)	MOCP (Maximum Overcurrent Protection)
			Min	Max							Stage 1	Stage 2	Total			
FAS300	208/230	STD	187	253	7.5	5.60	23.5	028A	208/240	20	15/20	—	15/20	41.7/48.1	81.5/89.5	90/90
			187	253	7.5	5.60	23.5	031A	208/240	40	15/20	15/20	30/40	83.4/96.2	133.6/149.6	150/150
			187	253	7.5	5.60	23.5	034A	208/240	50	22.6/30	15/20	37.6/50	104.3/120.3	159.8/179.8	175/200
			187	253	7.5	5.60	23.5	037A	208/240	70	30/40	22.6/30	52.6/70	145.9/168.4	211.8/239.9	225/250
		HIGH	187	253	10.0	7.46	32.0	028A	208/240	20	15/20	—	15/20	41.7/48.1	92.1/100.1	100/110
			187	253	10.0	7.46	32.0	031A	208/240	40	15/20	15/20	30/40	83.4/96.2	144.3/160.3	150/175
			187	253	10.0	7.46	32.0	034A	208/240	50	22.6/30	15/20	37.6/50	104.3/120.3	170.4/190.4	175/200
			187	253	10.0	7.46	32.0	037A	208/240	70	30/40	22.6/30	52.6/70	145.9/168.4	222.4/250.5	225/275
	460	STD	414	506	7.5	5.60	15.0	029A	480	20	20	—	20	24.1	48.9	50
			414	506	7.5	5.60	15.0	032A	480	40	20	20	40	48.1	78.9	80
			414	506	7.5	5.60	15.0	035A	480	50	30	20	50	60.1	93.9	100
			414	506	7.5	5.60	15.0	038A	480	70	40	30	70	84.2	124	125
		HIGH	414	506	10.0	7.46	16.0	029A	480	20	20	—	20	24.1	50.1	60
			414	506	10.0	7.46	16.0	032A	480	40	20	20	40	48.1	80.1	90
			414	506	10.0	7.46	16.0	035A	480	50	30	20	50	60.1	95.1	100
			414	506	10.0	7.46	16.0	038A	480	70	40	30	70	84.2	125.3	150
	575	STD	518	632	7.5	5.60	10.0	030A	575	20	20	—	20	20.1	37.6	40
			518	632	7.5	5.60	10.0	033A	575	40	20	20	40	40.2	62.8	70
			518	632	7.5	5.60	10.0	036A	575	50	30	20	50	50.2	75.3	80
			518	632	7.5	5.60	10.0	039A	575	70	40	30	70	70.3	100.4	110
		HIGH	518	632	10.0	7.46	13.0	030A	575	20	20	—	20	20.1	41.4	50
			518	632	10.0	7.46	13.0	033A	575	40	20	20	40	40.2	66.5	70
			518	632	10.0	7.46	13.0	036A	575	50	30	20	50	50.2	79	80
			518	632	10.0	7.46	13.0	039A	575	70	40	30	70	70.3	104.1	110

FAS150-336, 60 Hz Electrical Heater Data (cont)

Electrical data (cont)

UNIT	NOM. VOLTS	IFM TYPE	UNIT VOLTAGE		FAN MOTOR (QTY 1)			ELECTRIC HEATER(S)						POWER SUPPLY ^a		
			Range		hp	kW	FLA	CAEL HEAT ****00	Heater Voltage	Nom. Cap. (kW)	Actual Capacity (kW)			FLA (Full Load Amps)	MCA (Minimum Ckt Amps)	MOCP (Maximum Overcurrent Protection)
			Min	Max							Stage 1	Stage 2	Total			
FAS336	208/230	STD	187	253	10.0	7.46	32.0	028A	208/240	20	15/20	—	15/20	41.7/48.1	92.1/100.1	100/110
			187	253	10.0	7.46	32.0	031A	208/240	40	15/20	15/20	30/40	83.4/96.2	144.3/160.3	150/175
			187	253	10.0	7.46	32.0	034A	208/240	50	22.6/30	15/20	37.6/50	104.3/120.3	170.4/190.4	175/200
			187	253	10.0	7.46	32.0	037A	208/240	70	30/40	22.6/30	52.6/70	145.9/168.4	222.4/250.5	225/275
		HIGH	187	253	10.0	7.46	32.0	028A	208/240	20	15/20	—	15/20	41.7/48.1	92.1/100.1	100/110
			187	253	10.0	7.46	32.0	031A	208/240	40	15/20	15/20	30/40	83.4/96.2	144.3/160.3	150/175
			187	253	10.0	7.46	32.0	034A	208/240	50	22.6/30	15/20	37.6/50	104.3/120.3	170.4/190.4	175/200
			187	253	10.0	7.46	32.0	037A	208/240	70	30/40	22.6/30	52.6/70	145.9/168.4	222.4/250.5	225/275
	460	STD	414	506	10.0	7.46	16.0	029A	480	20	20	—	20	24.1	50.1	60
			414	506	10.0	7.46	16.0	032A	480	40	20	20	40	48.1	80.1	90
			414	506	10.0	7.46	16.0	035A	480	50	30	20	50	60.1	95.1	100
			414	506	10.0	7.46	16.0	038A	480	70	40	30	70	84.2	125.3	150
		HIGH	414	506	10.0	7.46	16.0	029A	480	20	20	—	20	24.1	50.1	60
			414	506	10.0	7.46	16.0	032A	480	40	20	20	40	48.1	80.1	90
			414	506	10.0	7.46	16.0	035A	480	50	30	20	50	60.1	95.1	100
			414	506	10.0	7.46	16.0	038A	480	70	40	30	70	84.2	125.3	150
	575	STD	518	632	10.0	7.46	13.0	030A	575	20	20	—	20	20.1	41.4	50
			518	632	10.0	7.46	13.0	033A	575	40	20	20	40	40.2	66.5	70
			518	632	10.0	7.46	13.0	036A	575	50	30	20	50	50.2	79	80
			518	632	10.0	7.46	13.0	039A	575	70	40	30	70	70.3	104.1	110
		HIGH	518	632	10.0	7.46	13.0	030A	575	20	20	—	20	20.1	41.4	50
			518	632	10.0	7.46	13.0	033A	575	40	20	20	40	40.2	66.5	70
			518	632	10.0	7.46	13.0	036A	575	50	30	20	50	50.2	79	80
			518	632	10.0	7.46	13.0	039A	575	70	40	30	70	70.3	104.1	110

NOTE(S):
a. MCA and MOCP values apply to both standard and alternate factory supplied motors.

Typical piping and wiring diagrams

Horizontal Installation — FAX/FAS

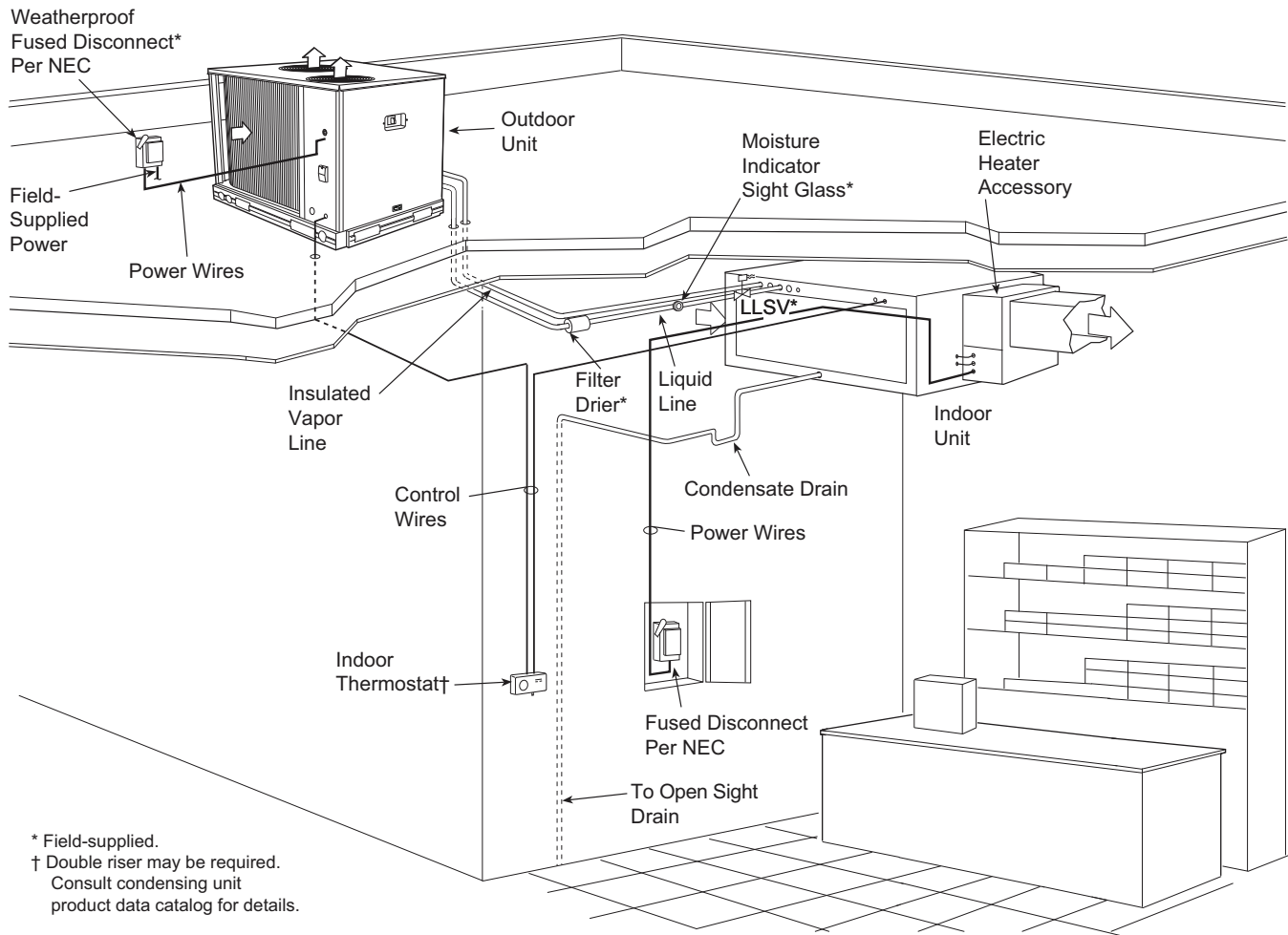

LEGEND

NEC — National Electrical Code
TXV — Thermostatic Expansion Valve

NOTES:

1. All piping must follow standard refrigerant piping techniques.
2. All wiring must comply with the applicable local and national codes.
3. Wiring and piping shown are general points-of-connection guides only and are not intended for, or to include all details for, a specific installation.
4. Liquid line solenoid valve (solenoid drop control) is recommended to prevent refrigerant migration to the compressor.
5. Internal factory-supplied TXVs not shown.

Typical piping and wiring diagrams (cont)

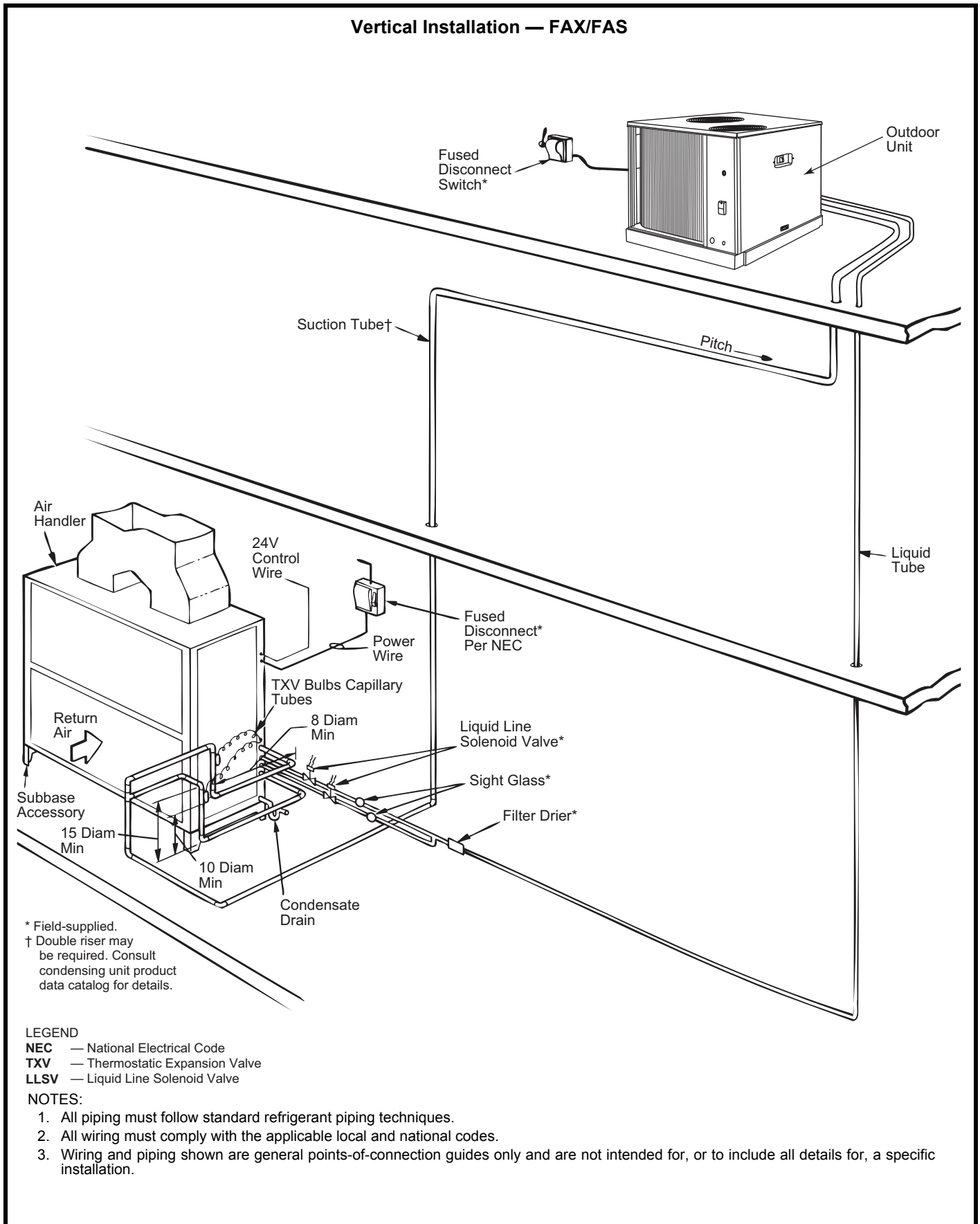

Typical piping and wiring diagrams (cont)

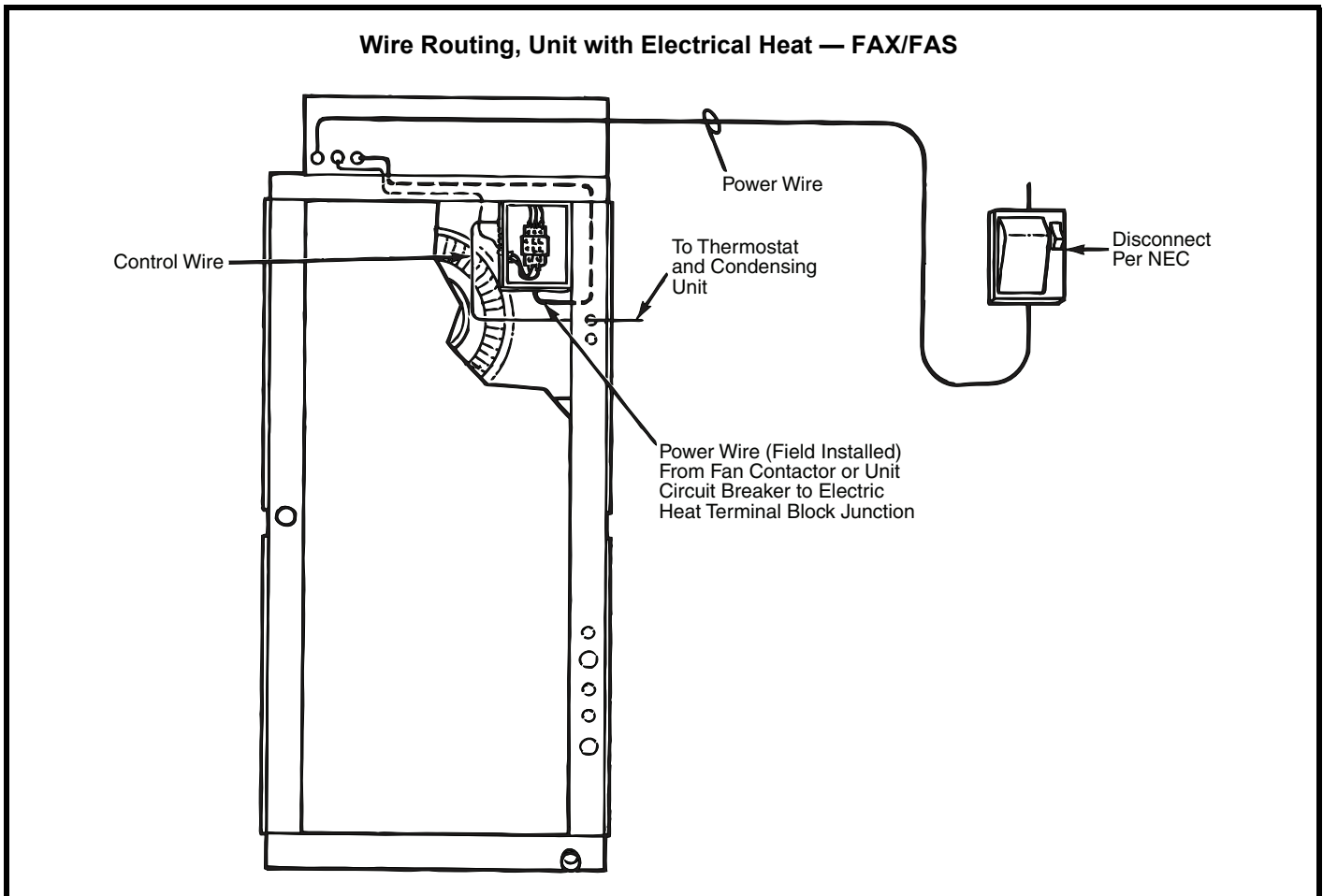
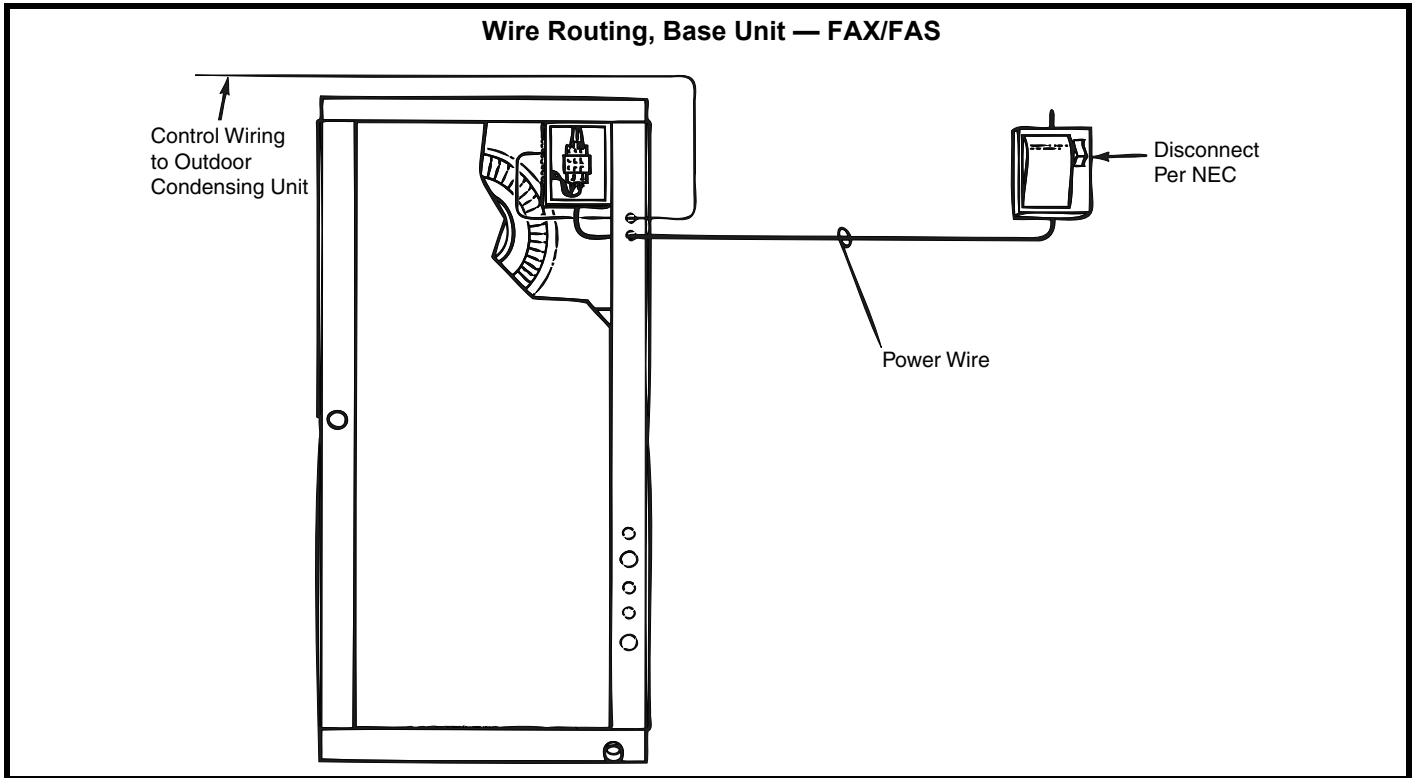

Typical piping and wiring diagrams (cont)

Unit Wiring Diagram — FAX072-120

NOTES:

1. TERMINAL BOARD SCHEMATIC LAYOUT DOES NOT MATCH ACTUAL TERMINAL BOARD LAYOUT.
2. REMOVE DESIGNATED JUMPERS ON TERMINAL BOARD WHEN ADDING SMOKE DETECTORS, OCCUPANCY AND REMOTE SHUTDOWN.
3. USE ABC AS COARSE AND POT AS FINE ADJUSTMENTS FOR SETTING HIGH FAN SPEED. LOW SPEED IS AN OFFSET BASED ON DIP SWITCHES.
4. 2-PIN LOW SPEED DIP SWITCH POSITIONS ARE FACTORY SET AS SHOWN.
5. TB2 LOCATED IN HEAT SECTION.
6. FREEZE PROTECTION SWITCH NORMALLY CLOSED. WILL OPEN WHEN THE EVAPORATOR COIL IS FROZEN.
7. WIRING SHOWN IS FOR 2 STAGE UNIT. TO CONVERT TO 3 STAGE UNIT:
 1. REMOVE GRA WIRE FROM T-STAT CB-X
 2. MOVE ORG WIRE FROM T-STAT CB-Y2 TO T-STAT CB-X
 3. BLU WIRE BETWEEN T-STAT CB-Y2 AND IDCB-Y2
 4. MOVE ORG WIRE FROM IDCB-Y2 TO IDCB-X

FIELD CONTROL WIRING

LEGEND

- | | | | |
|-----------|------------------------------|------|------------------------------|
| — | FACTORY WIRING | CB | CONNECTION BOARD |
| - - - | FIELD POWER WIRING | FLS | FAN LIMIT SWITCH |
| - · - · - | ACCESSORY OR OPTIONAL WIRING | FPR | FREEZE PROTECTION RELAY |
| | | FPT | FREEZE PROTECTION THERMOSTAT |
| | | IDCB | INDOOR CONNECTION BOARD |
| | | IFM | INDOOR FAN MOTOR |
| | | IFMC | INDOOR FAN MOTOR CONTROL |
| | | TB | TERMINAL BLOCK |

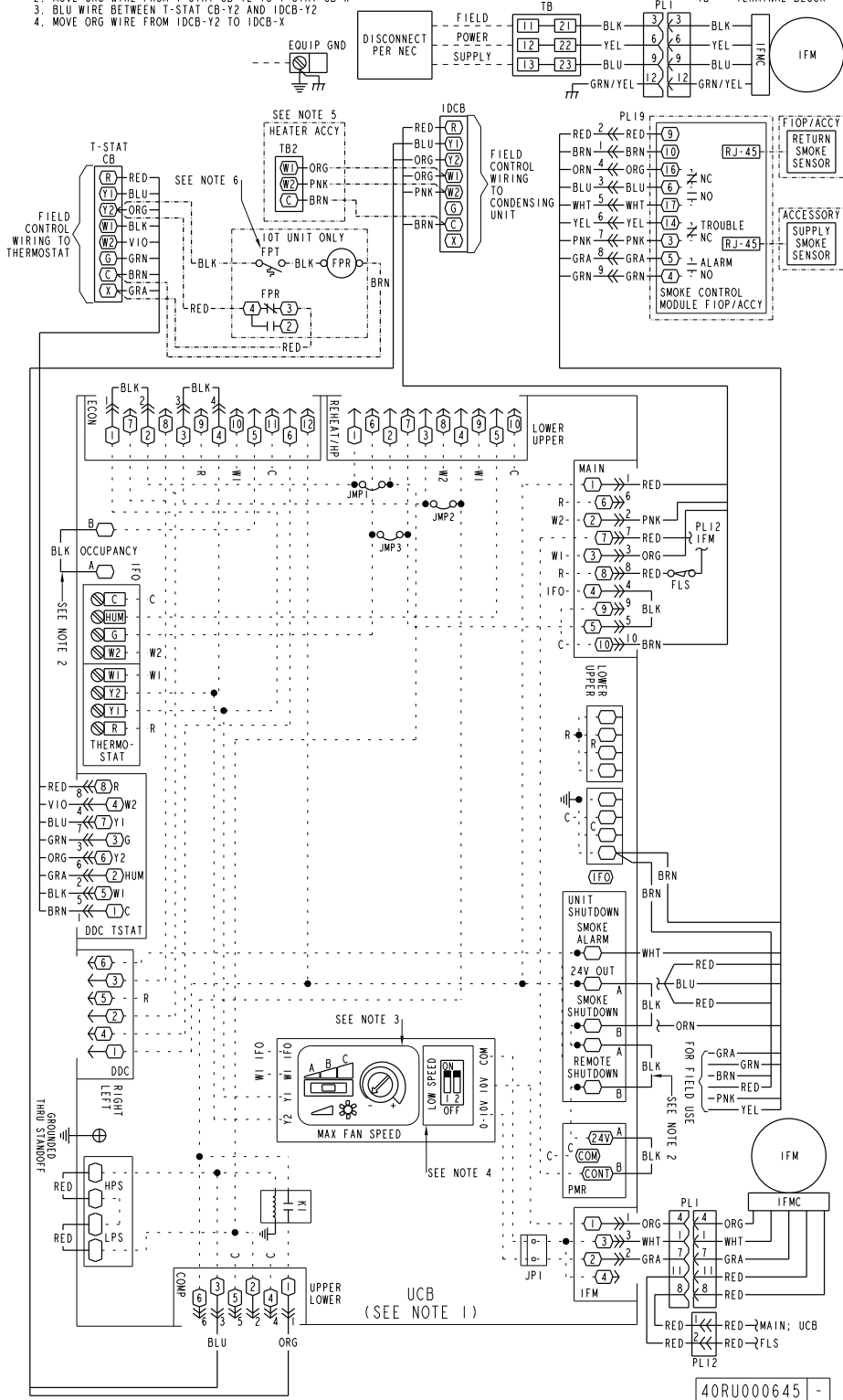

40RU000645 -

Application data

General

IMPORTANT: Do not bury refrigerant piping underground. Select equipment to match or to be slightly less than peak load. This provides better humidity control, less unit cycling, and less part-load operation. Equipment should be selected to perform at no less than 300 cfm/ton (40 L/s per kW).

The air handler fan must always be operating when the condensing unit is operating.

Ductwork should be sized according to unit size, not building load. For larger units with two fans, a split duct transition is recommended at the fan outlets, but a plenum can be used with slight reduction in external static pressure capability.

Auxiliary Side Connector Data

UNIT	PART NO.	INLET/OUTLET DIAMETER — ODF (in.)	AUXILIARY (HOT GAS) DIAMETER — ODF (in.)
FAX072	1178747	1-1/8	5/8
FAX091	1178748	1-3/8	7/8
FAX120	1178747	1-1/8	5/8
FAS150	1178747	1-1/8	5/8
FAS180	1178747	1-1/8	5/8
FAS240	1178747	1-1/8	5/8
FAS300	1178748	1-3/8	7/8
FAS336	1178748	1-3/8	7/8

Factory-Installed Nozzle and Distributor Data^a

UNIT	COIL TYPE	TXV QTY...P/N	DISTRIBUTOR QTY...P/N	FEEDER TUBES PER DISTRIBUTOR ^b QTY...SIZE (in.)	NOZZLE QTY...P/N
FAX072	4 Row	1...1178405 1...BBIZE-5-GA	1...1178408 1...1135	12...1/4	1...1178410 1...G4
FAX091	4 Row	1...1178406 1...BBIZE-6-GA	1...1178412 1...1136	15...1/4	1...1178411 1...G5
FAX120	4 Row	2...1196872 2...HXAE-5-KX	2...1178408 2...1135	9...1/4	2...1178409 2...G3
FAS150	4 Row	2...1193965 2...HXAE-6-KX	2...1178407 2...1113	12...3/16	2...1178409 2...G3
FAS180	4 Row	2...1178406 2...BBIZE-6-GA	2...1178412 2...1136	16...3/16	2...1178410 2...G4
FAS240	4 Row	2...1183553 2...BBIZE-8-GA	2...1175454 2...D196-18-3/16	18...3/16	2...1179769 2...G6
FAS300	4 Row	2...1183751 2...BBIZE-15-GA	2...1173485 2...1126	20...3/16	2...1179803 2...C15
FAS336	4 Row	2...1183751 2...BBIZE-15-GA	2...1173485 2...1126	24...3/16	2...1175908 2...C17

NOTE(S):

a. For FAS units, hot gas bypass applications require field-supplied auxiliary side connector.

b. Feeder tube size is 1/4 in. (6.35 mm).

LEGEND

TXV — Thermostatic Expansion Valve

Guide specifications — FAX

Commercial Packaged Air-Handling Unit

HVAC Guide Specifications

Size Range: **2,400 to 4,000 Cfm, Nominal Airflow, 6 to 10 Tons, Nominal Cooling**

Model: **FAX (Direct-Expansion Coil)**

Part 1 — General

1.01 System Description

- A. Indoor, packaged air-handling unit for use in commercial split systems. Unit shall have a multi-position design and shall be capable of horizontal or vertical installation on a floor or in a ceiling, with or without ductwork. (Only vertical units are to be applied without ductwork.)
- B. Unit with direct-expansion coil shall be used in a refrigerant circuit with a matching air-cooled condensing unit.

1.02 Quality Assurance

- A. Coils shall be designed and tested in accordance with ASHRAE 15 Safety Code for Mechanical Refrigeration (U.S.A.), latest edition.
- B. Unit shall be constructed in accordance with UL (U.S.A.) and UL, Canada, standards and shall carry the UL and UL, Canada, labels.
- C. Unit insulation and adhesive shall comply with NFPA-90A (U.S.A.) requirements for flame spread and smoke generation. Insulation shall be treated with an immobilized antimicrobial agent to inhibit the growth of bacteria and fungi on the insulation as proven by tests in accordance with ASTM standards G21 and 22 (U.S.A.).
- D. Unit shall be manufactured in a facility registered to the ISO 9001 manufacturing quality standard.
- E. Direct-expansion coils shall be burst and leak tested at 435 psi.

1.03 Delivery And Storage

- A. Units shall be stored and handled per manufacturer's recommendations.

Part 2 — Products

2.01 Equipment

- A. Indoor mounted, draw-thru, packaged air-handling unit that can be used in a suspended horizontal configuration or a vertical configuration. Unit shall consist of a direct drive vane axial fan and motor assembly, pre-wired fan motor controller, factory-installed refrigerant metering devices (direct-expansion coil units), cooling coil, 2 in. (51 mm) disposable air filters, and condensate drain pans for vertical or horizontal configurations.
 1. Cabinet shall be constructed of mill-galvanized steel.
 2. Cabinet panels shall be fully insulated with 1/2 in. (12.7 mm) fire-retardant material. Insulation shall be treated with an immobilized antimicrobial agent to inhibit the growth of bacteria and fungi on the insulation as proven by

tests in accordance with ASTM standards G21 and 22 (U.S.A.).

3. Unit shall contain non-corroding condensate drain pans for both vertical and horizontal applications. Drain pans shall have connections on right and left sides of unit to facilitate field connection. Drain pans shall have the ability to be sloped toward the right or left side of the unit to prevent standing water from accumulating in pans.
 4. Unit shall have factory-supplied 2 in. (51 mm) throwaway-type filters installed upstream from the cooling coil. Filter access shall be from either the right or left side of the unit.
- B. Evaporator Fan and Motor with X-Vane Fan Technology:
1. Direct Drive Evaporator fan motor:
 - a. Shall be an ECM motor design.
 - b. Shall have permanently lubricated bearings.
 - c. Shall have inherent automatic-reset thermal overload protection.
 - d. Shall have slow ramp up to speed capabilities.
 - e. Shall require no fan/motor belts for operation, adjustments and or initial fan speed set up.
 - f. Shall be internally protected from electrical phase reversal and loss.
 2. Evaporator Fan:
 - a. Shall be easily set with dedicated selection switch and adjustment pot on unit control board.
 - b. Shall provide two stage cooling capacity control, the indoor fan speed is automatically controlled to meet the code-compliant <66% low fan speed and 100% at full fan speed operation.
 - c. Blower fan shall be a Vane Axial fan design with 75% less moving parts than a conventional belt drive system.
 - d. Shall be constructed of a high impact composite material on stator, rotor and air inlet casing.
 - e. Shall be a patented / pending design with a corrosion resistant material and dynamically balanced.
 - f. Shall have slow ramp up to speed capabilities to help reduce sound and comfort issues typically associated with single speed belt drive systems.
 - g. Shall be a slide out design with removal of a few support brackets.
 3. Shall include an easily accessible Unit Control Board to conveniently and safely provide connection points for vital control functions such as: smoke detectors, phase monitor, economizer, thermostat, and low and high pressure

Guide specifications — FAX (cont)

switches. Controller shall also provide an intuitive means to adjust the indoor fan speed through a simple switch and pot adjustment design.

C. Coils:

DX coil is 4-row and consists of copper tubes with sine-wave aluminum fins bonded to the tubes by mechanical expansion. Suction and liquid line connections or supply and discharge connections shall be made on the same side of the coil.

Direct-expansion coils shall feature factory-installed thermostatic expansion valves (TXVs) for refrigerant control. The TXVs shall be R-410A compatible and capable of external adjustment. Coil tubing shall be internally rifled to maximize heat transfer.

D. Operating Characteristics:

1. When combined with matching CAS condensing unit the system shall be capable of starting and running at ambient outdoor temperatures from 35°F (2°C) to 125°F (52°C) in cooling mode.
2. Unit shall operate at $\pm 10\%$ from rated voltage.

E. Motor:

1. Fan motor of the size and electrical characteristics specified on the equipment schedule shall be factory supplied and installed.
2. Evaporator motors are designed specifically for our units and do not have conventional horsepower (hp) ratings listed on the motor nameplate. Motors are designed and qualified in the "air-over" location downstream of the cooling coil and carry a maximum continuous bhp rating that is the maximum application bhp rating for the motor; no "safety factors" above that rating may be applied.

F. Special Features:

1. Alternate Motor and Drive:

An alternate high-static motor shall be available to meet the airflow and external static pressure requirements specified on the equipment schedule.

2. External Paint:

Where conditions require, units shall be painted with an American Sterling Gray finish.

3. Hot Water Coil:

Coil shall be 2-row, U-bend coil with copper tubes and aluminum plate fins bonded to the tubes by mechanical expansion. Coil shall be mounted in a galvanized steel housing that shall be fastened to the unit's fan deck for blow-thru heating operation. Coil shall have maximum working pressure of 150 psig.

4. Steam Distributing Coil:

Coil shall consist of one row of copper tubes with aluminum plate fins, and shall have inner

steam distributing tubes. Coil shall be mounted in a galvanized steel housing and shall be fastened to the unit's fan deck for blow-thru heating operation. Coil shall have maximum working pressure of 20 psig at 260°F.

5. Electric Heaters:

Heaters for nominal 240v, 480v, or 575v, 3-phase, 60 Hz shall be factory-supplied and field-installed as shown on the equipment drawings. Electric heat assembly shall be ETL (U.S.A.) and ETL, Canada, agency approved, and shall have single-point power wiring. Heater assembly shall include contactors with 24-v coils, power wiring, 24-v control wiring terminal blocks, and a hinged access panel. Electric heaters shall not be used with air discharge plenum.

6. Air Discharge Plenum:

Plenum shall be factory-supplied for field installation to provide free-blow air distribution for vertical floor-mounted units. A grille with movable vanes for horizontal or vertical airflow adjustment shall be included. Plenum shall be field-assembled and field-installed on the unit's fan deck for blow-thru air distribution. Plenum shall not be used with electric heaters.

7. Return-Air Grille:

Grille shall be factory-supplied for field installation on the unit's return air opening.

8. Unit Subbase:

Subbase assembly shall be factory-supplied for field installation. Subbase shall elevate floor-mounted vertical units to provide access for correct condensate drain connection.

9. Economizers:

a. Accessory Ultra Low Leak EconoMi\$er X (Field-installed) Economizer for ventilation or "free" cooling shall be factory provided for field installation on either return air opening of air handler.

- 1) Integrated, gear driven opposing modulating blade design type capable of simultaneous economizer and compressor operation.

- 2) Damper blades shall be galvanized steel with composite gears. Plastic or composite blades on intake or return shall not be acceptable.

- 3) Shall include all hardware, actuator and controls to provide free cooling with outdoor air when temperature and/or humidity are below setpoints.

- 4) Shall be equipped with gear driven dampers for both the outdoor ventilation air and the return air for positive air stream control.

Guide specifications — FAX (cont)

- 5) Ultra Low Leak design meets California Title 24 section 140.4 and ASHRAE 90.1 requirements for 4 cfm per sq ft on the outside air dampers and 10 cfm per sq ft on the return dampers.
- 6) Economizer controller on EconoMi\$er X models shall be the Honeywell W7220 that provides:
 - a) 2-line LCD interface screen for setup, configuration and troubleshooting.
 - b) On-board Fault Detection and Diagnostics (FDD) that senses and alerts when the economizer is not operating properly, per California Title 24.
 - c) Sensor failure loss of communication identification.
 - d) Automatic sensor detection.
 - e) Capabilities for use with multiple-speed indoor fan systems.
 - f) Utilizing digital sensors: Dry bulb and Enthalpy. Accessory comes standard with dry bulb sensing.
 - g) Field installing enthalpy sensor required.
- b. Accessory Standard Leak EconoMi\$er IV (field-installed) Economizer for ventilation or “free” cooling shall be factory provided for field installation on either return air opening of air handler.
 - 1) Integrated, gear driven opposing modulating blade design type capable of simultaneous economizer and compressor operation.
 - 2) Damper blades shall be galvanized steel with composite gears. Plastic or composite blades on intake or return shall not be acceptable.
 - 3) Shall include all hardware, actuator and controls to provide free cooling with outdoor air when temperature and/or humidity are below setpoints.
- 4) Shall be equipped with gear driven dampers for both the outdoor ventilation air and the return air for positive air stream control.
- 5) Standard leak rate shall be equipped with dampers not to exceed 2% leakage at 1 in. wg pressure differential.
- 6) Economizer controller on EconoMi\$er IV models shall be Honeywell W7212 that provides:
 - a) Combined minimum and DCV maximum damper position potentiometers with compressor staging relay.
 - b) Functions with solid state analog enthalpy or dry bulb changeover control sensing.
 - c) Contains LED indicates for when free cooling is available, when module is in DCV mode, when exhaust fan is closed.
10. Overhead Suspension Package:

Package shall include necessary brackets to support units in a horizontal ceiling installation.
11. CO₂ Sensor:

Sensor shall provide the ability to signal the economizer to open when the space CO₂ level exceeds the predetermined setpoint.
12. Condensate Drain Trap:

Trap shall have transparent, serviceable design for easy cleaning. Kit shall include overflow shutoff switch and wiring harness for connection to an alarm if desired.
13. Discharge Duct Adapter:

Adapter shall be required for replacements using FAX units with or without electric heat. It shall not be required for new installations or when using steam coil, hot water coil, or discharge plenum accessories.

Guide specifications — FAS

Commercial Packaged Air-Handling Unit

HVAC Guide Specifications

Size Range: **5,000 to 12,000 Cfm, Nominal Airflow, 12.5 to 30 Tons, Nominal Cooling**

Model: **FAS (Direct-Expansion Coil)**

Part 1 — General

1.01 System Description

- A. Indoor, packaged air-handling unit for use in commercial split systems. Unit shall have a multi-position design and shall be capable of horizontal or vertical installation on a floor or in a ceiling, with or without ductwork. (Only vertical units are to be applied without ductwork.)
- B. Unit with direct-expansion coil shall be used in a refrigerant circuit with a matching air-cooled condensing unit.

1.02 Quality Assurance

- A. Coils shall be designed and tested in accordance with ASHRAE 15 Safety Code for Mechanical Refrigeration (U.S.A.), latest edition.
- B. Unit shall be constructed in accordance with ETL (U.S.A.) and ETL, Canada, standards and shall carry the ETL and ETL, Canada, labels.
- C. Unit insulation and adhesive shall comply with NFPA-90A (U.S.A.) requirements for flame spread and smoke generation. Insulation shall be treated with an immobilized antimicrobial agent to inhibit the growth of bacteria and fungi on the insulation as proven by tests in accordance with ASTM standards G21 and 22 (U.S.A.).
- D. Unit shall be manufactured in a facility registered to the ISO 9001 manufacturing quality standard.
- E. Direct-expansion coils shall be burst and leak tested at 435 psi.

1.03 Delivery And Storage

- A. Units shall be stored and handled per manufacturer's recommendations.

Part 2 — Products

2.01 Equipment

- A. Indoor mounted, draw-thru, packaged air-handling unit that can be used in a suspended horizontal configuration or a vertical configuration. Unit shall consist of forward-curved belt-driven centrifugal fan(s), motor and drive assembly, pre-wired fan motor contactor, factory-installed refrigerant metering devices (direct-expansion coil units), cooling coil, 2 in. (51 mm) disposable air filters, and condensate drain pans for vertical or horizontal configurations.
 1. Cabinet shall be constructed of mill-galvanized steel.
 2. Cabinet panels shall be fully insulated with 1/2 in. (12.7 mm) fire-retardant material. Insulation shall be treated with an immobilized antimicrobial agent to inhibit the growth of

bacteria and fungi on the insulation as proven by tests in accordance with ASTM standards G21 and 22 (U.S.A.).

3. Unit shall contain non-corroding condensate drain pans for both vertical and horizontal applications. Drain pans shall have connections on right and left sides of unit to facilitate field connection. Drain pans shall have the ability to be sloped toward the right or left side of the unit to prevent standing water from accumulating in pans.
4. Unit shall have factory-supplied 2 in. (51 mm) throwaway-type filters installed upstream from the cooling coil. Filter access shall be from either the right or left side of the unit.

B. Coils:

DX coil is 4-row and consists of copper tubes with sine-wave aluminum fins bonded to the tubes by mechanical expansion. Suction and liquid line connections or supply and discharge connections shall be made on the same side of the coil.

Direct-expansion coils shall feature factory-installed thermostatic expansion valves (TXVs) for refrigerant control. The TXVs shall be R-410A compatible and capable of external adjustment. Coil tubing shall be internally rifled to maximize heat transfer. The FAS300 and 336 have 1179823 TXVs. These are Sporlan™¹ BBIZE-15-GA-BP5, part no. 1183751, which have a 5% bleed.

C. Operating Characteristics:

1. When combined with matching CAS condensing unit the system shall be capable of starting and running at ambient outdoor temperatures from 35°F (2°C) to 125°F (52°C) in cooling mode and from -10°F (-23°C) to 60°F (16°C) in heating mode.
2. Unit shall operate at ±10% from rated voltage.

D. Motor:

1. Fan motor of the size and electrical characteristics specified on the equipment schedule shall be factory supplied and installed.
2. Motors rated at 1.3 through 3.7 hp shall have inherent thermal overload protection. Motors rated at 5 hp shall be protected by a circuit breaker.
3. Evaporator-fan motor shall have permanently lubricated, sealed bearings and inherent automatic-reset thermal overload protection or manual reset calibrated circuit breakers. Evaporator motors are designed specifically for our units and do not have conventional horsepower (hp) ratings listed on the motor nameplate. Motors are designed and qualified in the "air-over" location downstream of the

1. Third-party trademarks and logos are the property of their respective owners.

Guide specifications — FAS (cont)

cooling coil and carry a maximum continuous bhp rating that is the maximum application bhp rating for the motor; no “safety factors” above that rating may be applied.

4. All evaporator-fan motors 5 hp and larger shall meet the minimum efficiency requirements as established by the Energy Policy Act of 1992 (EPACT, U.S.A.), effective October 24, 1997.

E. Control Box:

1. Shall include an easily accessible Unit Control Board to conveniently and safely provide connection points for vital control functions such as: smoke detectors, phase monitor, economizer, thermostat, and low and high pressure switches. Controller shall also provide an intuitive means to adjust the indoor fan speed through a simple switch and pot adjustment design.

F. 2-Speed Indoor Fan Motor System for 2-stage cooling models (standard):

1. Evaporator fan motor.
 - a. Shall have permanently lubricated bearings.
 - b. Shall have a maximum continuous bhp rating for continuous duty operation; no safety factors above that rating.
 - c. Shall be Variable Frequency duty and 2-speed control.
 - d. Shall contain motor shaft grounding ring to prevent electrical bearing fluting damage by safely diverting harmful shaft voltages and bearing currents to ground.
2. Variable Frequency Drive (VFD) Standard:
 - a. Shall be installed inside the unit cabinet, mounted, wired and tested.
 - b. Shall contain Electromagnetic Interference (EMI) frequency protection.
 - c. Insulated Gate Bi-Polar Transistors (IGBT) used to produce the output pulse width modulated (PWM) wave-form, allowing for quiet motor operation.
 - d. Self diagnostics with fault and power code LED indicator. Field accessory Display Kit available for further diagnostics and special setup applications.
 - e. RS485 capability standard.
 - f. Electronic thermal overload protection.
 - g. 5% swinging chokes for harmonic reduction and improved power factor.
 - h. All printed circuit boards shall be conformal coated.

G. Special Features:

1. Alternate Motor and Drive:

An alternate motor and/or high-static drive shall be available to meet the airflow and external static pressure requirements specified on the equipment schedule.

2. External Paint:

Where conditions require, units shall be painted with an American Sterling Gray finish.

3. Hot Water Coil:

Coil shall be 2-row, U-bend coil with copper tubes and aluminum plate fins bonded to the tubes by mechanical expansion. Coil shall be mounted in a galvanized steel housing that shall be fastened to the unit's fan deck for blow-thru heating operation. Coil shall have maximum working pressure of 150 psig.

4. Steam Distributing Coil:

Coil shall consist of one row of copper tubes with aluminum plate fins, and shall have inner steam distributing tubes. Coil shall be mounted in a galvanized steel housing and shall be fastened to the unit's fan deck for blow-thru heating operation. Coil shall have maximum working pressure of 20 psig at 260°F.

5. Electric Heaters:

Heaters for nominal 240v, 480v, or 575v, 3-phase, 60 Hz shall be factory-supplied and field-installed as shown on the equipment drawings. Electric heat assembly shall be ETL (U.S.A.) and ETL, Canada, agency approved, and shall have single-point power wiring. Heater assembly shall include contactors with 24-v coils, power wiring, 24-v control wiring terminal blocks, and a hinged access panel. Electric heaters shall not be used with air discharge plenum.

6. Air Discharge Plenum:

Plenum shall be factory-supplied to provide free-blow air distribution for vertical floor-mounted units. A grille with movable vanes for horizontal or vertical airflow adjustment shall be included. Plenum shall be field-assembled and field-installed on the unit's fan deck for blow-thru air distribution. Plenum shall not be used with electric heaters.

7. Return-Air Grille:

Grille shall be factory-supplied for field installation on the unit's return air opening.

8. Unit Subbase:

Subbase assembly shall be factory-supplied for field installation. Subbase shall elevate floor-mounted vertical units to provide access for correct condensate drain connection.

9. Economizers:

a. Accessory Ultra Low Leak EconoMiSer X. (Field-installed) Economizer for ventilation or “free” cooling shall be factory provided for field installation on either return air opening of air handler.

- 1) Integrated, gear driven opposing modulating blade design type capable of

Guide specifications — FAS (cont)

- simultaneous economizer and compressor operation.
- 2) Damper blades shall be galvanized steel with composite gears. Plastic or composite blades on intake or return shall not be acceptable.
 - 3) Shall include all hardware, actuator and controls to provide free cooling with outdoor air when temperature and/or humidity are below setpoints.
 - 4) Shall be equipped with gear driven dampers for both the outdoor ventilation air and the return air for positive air stream control.
 - 5) Ultra Low Leak design meets California Title 24 section 140.4 and ASHRAE 90.1 requirements for 4 cfm per sq ft on the outside air dampers and 10 cfm per sq ft on the return dampers.
 - 6) Economizer controller on EconoMi\$er X models shall be the Honeywell W7220 that provides:
 - a) 2-line LCD interface screen for setup, configuration and troubleshooting.
 - b) Onboard Fault Detection and Diagnostics (FDD) that senses and alerts when the economizer is not operating properly, per California Title 24.
 - c) Sensor failure loss of communication identification.
 - d) Automatic sensor detection.
 - e) Capabilities for use with multiple-speed indoor fan systems.
 - f) Utilizing digital sensors: Dry bulb and Enthalpy. Accessory comes standard with dry bulb sensing.
 - g) Field installing enthalpy sensor required.
- b. Accessory Standard Leak EconoMi\$er IV (field-installed) Economizer for ventilation or “free” cooling shall be factory provided for field installation on either return air opening of air handler.
- 1) Integrated, gear driven opposing modulating blade design type capable of simultaneous economizer and compressor operation.
 - 2) Damper blades shall be galvanized steel with composite gears. Plastic or composite blades on intake or return shall not be acceptable.
 - 3) Shall include all hardware, actuator and controls to provide free cooling with outdoor air when temperature and/or humidity are below setpoints.
 - 4) Shall be equipped with gear driven dampers for both the outdoor ventilation air and the return air for positive air stream control.
 - 5) Standard leak rate shall be equipped with dampers not to exceed 2% leakage at 1 in. wg pressure differential.
 - 6) Economizer controller on EconoMi\$er IV models shall be Honeywell W7212 that provides:
 - a) Combined minimum and DCV maximum damper position potentiometers with compressor staging relay.
 - b) Functions with solid state analog enthalpy or dry bulb changeover control sensing.
 - c) Contains LED indicates for when free cooling is available, when module is in DCV mode, when exhaust fan is closed.
10. Overhead Suspension Package:

Package shall include necessary brackets to support units in a horizontal ceiling installation.
 11. CO₂ Sensor:

Sensor shall provide the ability to signal the economizer to open when the space CO₂ level exceeds the predetermined setpoint.
 12. Condensate Drain Trap:

Trap shall have transparent, serviceable design for easy cleaning. Kit shall include overflow shutoff switch and wiring harness for connection to an alarm if desired.

© 2023 Carrier
Lewisburg, Tennessee 37091 USA
www.GoDayandNight.com

Manufacturer reserves the right to discontinue, or change at any time, specifications or designs without notice and without incurring obligations.