



aerospace
climate control
electromechanical
filtration
fluid & gas handling
hydraulics
pneumatics
process control
sealing & shielding



Thermostatic and Automatic Expansion Valves

Catalog E-1, October 2007



ENGINEERING YOUR SUCCESS.

Table of Contents

Thermostatic Expansion Valves (TEVs) and Constant Pressure (Automatic) Expansion Valves (AEVs)

Visual Table of Contents	3
Thermostatic Expansion Valves	
Model Number Selection Guide - N, C(E), SC(E), EC(E) Valves	4
N Series	5
C(E) Series	6
SC(E) Series	7
EC(E) Series	8
H Series	9
HC Series	9
Model Number Selection Guide - EBS, OE Valves	11
EBS Series	12
OE Series	13
Capacity Tables	14
Constant Pressure (Automatic) Expansion Valves	
A Series Valves	18
Capacity Tables	20

Visual Table of Contents



N Series TEV
page 5
Applications:
Low Profile Coolers,
Ice Machines,
Beverage Dispensers



C(E) Series TEV
page 6
Applications:
Rail and Transport
Refrigeration,
Supermarket Cases,
Walk-in Coolers



SC(E) Series TEV
page 7
Applications:
Supermarket Cases,
Walk-in Freezers,
Ice Machines



EC(E) Series TEV
page 8
Applications:
Supermarket Cases,
Transport Refrigeration,
Walk-in Coolers



H Series TEV
page 9
Applications:
Air Conditioning,
Heat Pumps, Bi-flow
(Package Systems)



HC Series TEV
page 9
Applications:
Air Conditioning,
Heat Pumps



EBS Series TEV
page 12
Applications:
Air Conditioning,
Industrial Chillers



OE Series TEV
page 13
Applications:
Air Conditioning,
Industrial Chillers



AT Series AEV
page 18
Applications:
Ice Cream/Slush
Machines,
Hot Gas Bypass,
Freeze Protection,
Refrigerant Reclaim,
PTAC/PTHP, High Cycle



A7 Series AEV
page 18
Applications:
Ice Cream/Slush
Machines,
Hot Gas Bypass,
Freeze Protection,
Refrigerant Reclaim,
PTAC/PTHP, High Cycle



AS Series AEV
page 18
Applications:
Ice Cream/Slush
Machines,
Hot Gas Bypass,
Freeze Protection,
Refrigerant Reclaim,
Vending, Ice Machines



A1 Series AEV
page 18
Applications:
Ice Cream/Slush
Machines,
Hot Gas Bypass,
Freeze Protection,
Refrigerant Reclaim,
Vending, Ice Machines



A2 Series AEV
page 19
Applications:
Ice Cream/Slush
Machines,
Hot Gas Bypass,
Freeze Protection,
Refrigerant Reclaim,
Vending, Ice Machines



A3 Series AEV
page 19
Applications:
Ice Cream/Slush
Machines,
Hot Gas Bypass,
Freeze Protection,
Refrigerant Reclaim,
Vending, Ice Machines



A4 Series AEV
page 19
Applications:
Ice Cream/Slush
Machines,
Hot Gas Bypass,
Freeze Protection,
Refrigerant Reclaim,
Vending, Ice Machines

TEV Model Number Selection Guide

Nomenclature (Example) – N, C(E), SC(E), EC(E) Valves

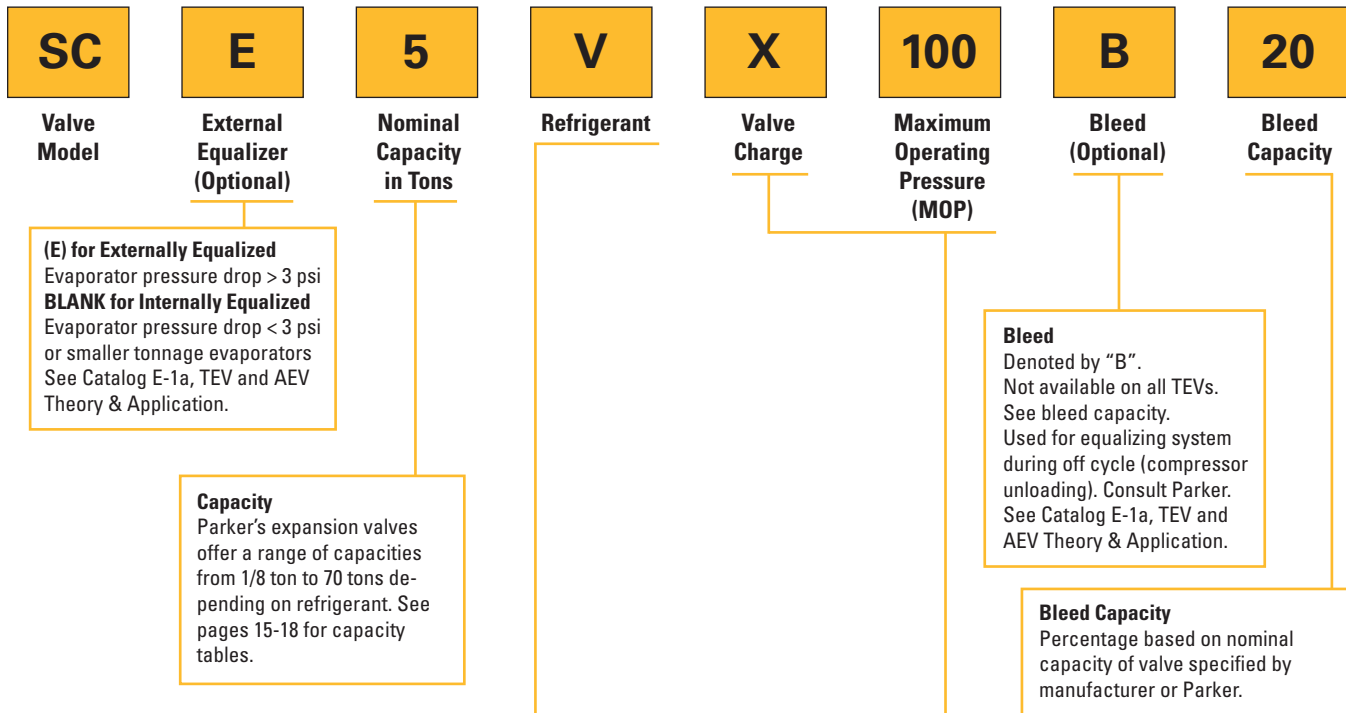

Rainbow Charge™ Refrigerant Designation

Z	R-410A
J	R-134a, R-401A (MP39), R-401B (MP66)
V	R-407C (AC9000), R-22
S	R-125, R-404A (HP62), R-402A (HP80), R-402B (HP81), R-507 (AZ50)

Refrigerant

Color Code

- R-12 - yellow
- R-22 - green
- R-134a - light blue
- R-404A - orange
- R-407C - light brown
- R-410A - rose
- R-502 - purple
- HP80 - canary
- HP81 - olive

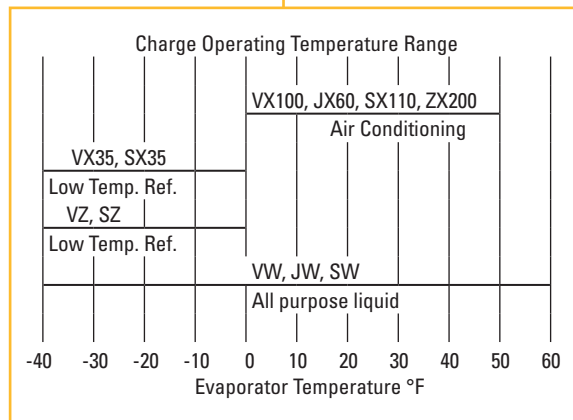

†Charge Type

"W" (all-purpose) liquid charge maintains nearly flat superheat control over a -40°F to +60°F (-40°C to +15°C) evaporator temperature range.

"Z" (low temperature) charge provides fast pulldown benefits like a gas charge with the non-migrating benefits of a liquid charge; usable over a -40°F to 0°F (-40°C to -20°C) evaporator temperature range.

"X" (damped response) gas charge provides a pressure limiting (MOP) charge with anti-hunt characteristics over a -40°F to +60°F (-40°C to +15°C) evaporator temperature range.

Notes: M.O.P. not available on "W" or "Z" charge.

1. Maximum operational pressure 500 psig (35 bar) high side and 275 psig (19 bar) low side.
2. Maximum storage temperature 130°F (55°C).
3. Consult Parker for pressure and temperature exceptions.
4. Do not use "W" or "Z" liquid charges in applications where bulb temperatures can exceed 130°F (55°C).
 For these applications use type "X" MOP gas charge **only**.

N Series

This small flare brass valve series is ideally suited where space is at a premium. Its stainless steel power element and compact body has always made it the first choice for installation in commercial refrigeration systems. External equalized models are provided with a 30" capillary and 1/4" SAE flare nut, eliminating the need to run a separate equalizer line. Medium, low & MOP "X" charges are available as noted below.



Applications

- Low Profile Coolers
- Beverage Dispensers
- Beverage Boxes
- Small Chillers
- Ice Machines
- Small Freezers

Features and Benefits

- Compact body
- Inlet strainer
- Factory set superheat
- Accurate and stable control
- Right angle configuration
- 30" capillary tube
- Weight: 5.0 oz. / .14 kg

Specifications

Refrigerant	Refrigerant Designation	Nominal Capacity (Tons)	Internally Equalized	Externally Equalized	Rainbow Charges™	Inlet Connection (Inches)	Outlet Connection (Inches)
R-12 R-134a R-401A R-401B	J	1/4 1/2 2	N-1/4-J N-1/2-J N-2-J	— — NE-2-J	W, X60	1/4 SAE 3/8 SAE	1/2 SAE
R-402A R-402B R-404A R-502 R-507	S	1/2 1/4 2	N-1/2-S N-1/4-S N-2-S	— — NE-2-S	W, Z, X110	1/4 or 3/8 SAE 1/4 SAE 3/8 SAE	1/2 SAE
R-22 R-407C	V	1/4 1/2 1 3	N-1/4-V N-1/2-V N-1-V N-3-V	— — — NE-3-V	W, Z, X100	1/4 SAE 1/4 or 3/8 SAE 3/8 SAE	1/2 SAE

Dimensions – Inches

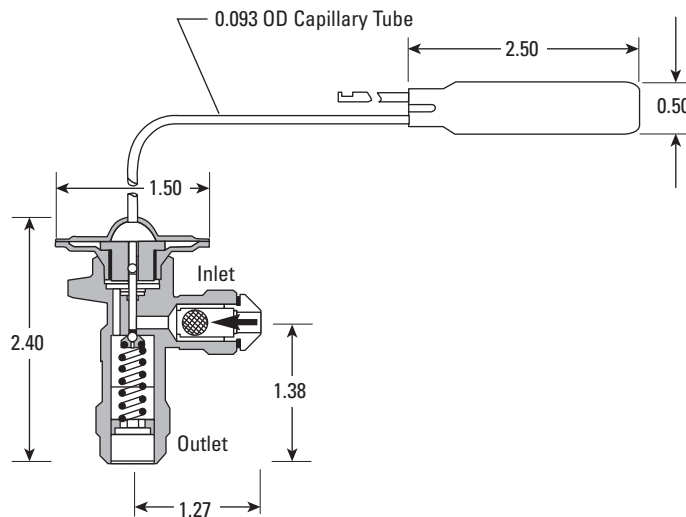

C(E) Series

The C(E) series incorporates an angle style brass body with SAE flare fittings using balanced port construction, allowing operation over varying load conditions. Designed for use on small refrigeration and or air conditioning systems, the external equalized models are provided with a 1/4" SAE male connection.

Applications

- Small Refrigeration Systems
- Slush Machines
- Air Conditioning Units
- Freezers
- Walk-in Coolers
- Refrigerated Cases
- Rail & Transport Refrigeration

Features and Benefits

- Balanced port design
- Removable power element
- Inlet strainer – 100 mesh
- 60" capillary tube
- Field adjustable superheat
- 1/4" SAE external equalizer
- Weight: 1.0 lbs / 0.45 kg



Specifications – Element Size No. 46

Refrigerant	Refrigerant Designation	Orifice Designation	Nominal Capacity (Tons)	Internally Equalized	Externally Equalized	Rainbow Charges™	Inlet Connection (Inches)	Outlet Connection (Inches)	Equalizer Connection (Inches)
R-12 R-134a R-401A R-401B	J	AA A B C D	1/8 to 1/2 1/2 to 1 1 to 2 1-1/2 to 3 3-1/2 to 5	C-AA-J C-A-J C-B-J C-C-J N/A	CE-AA-J CE-A-J CE-B-J CE-C-J CE-D-J	W, X60	1/4 SAE (3/8 optional)	1/2 SAE	1/4 SAE
R-402A R-402B R-404A R-502 R-507	S	AA A B C D	1/8 to 1/2 1/2 to 1 1-1/2 to 2-1/2 3 to 4 5 to 6	C-AA-S C-A-S C-B-S C-C-S N/A	CE-AA-S CE-A-S CE-B-S CE-C-S CE-D-S	W, Z, X35	1/4 SAE (3/8 optional)	1/2 SAE	1/4 SAE
R-22 R-407C	V	AA A B C D	1/8 to 1/2 1/2 to 1-1/2 2 to 3 3-1/2 to 5 5 to 6	C-AA-V C-A-V C-B-V C-C-V N/A	CE-AA-V CE-A-V CE-B-V CE-C-V CE-D-V	W, Z, X100 X35	1/4 SAE (3/8 optional)	1/2 SAE	1/2 SAE

Dimensions – Inches

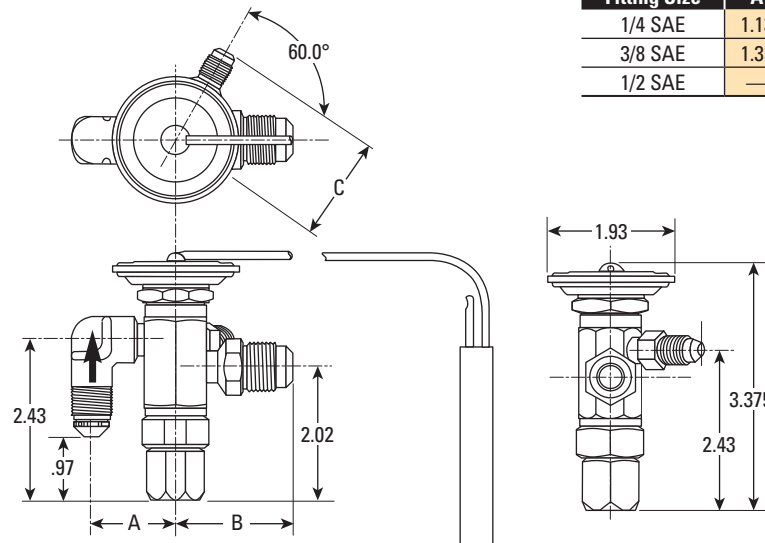

Fitting Size	A	B	C
1/4 SAE	1.13	—	1.54
3/8 SAE	1.35	—	—
1/2 SAE	—	1.80	—

SC(E) Series

The SC(E) series refrigeration right angle brass body expansion valve incorporates a removable inlet strainer that may be replaced or cleaned without removing the valve from the system, and is an ideal choice for commercial refrigeration and supermarket applications.

Applications

- Supermarket Cases
- Self-contained Cases
- Walk-in Coolers/Freezers
- Ice Machines
- Salad Bars
- Transport Refrigeration

Features and Benefits

- Removable power element
- 60" capillary tube
- Removable inlet strainer – 100 mesh
- Field adjustable superheat
- 1/4" ODF external equalizer
- "W", "Z" or MOP "X" charges available
- Weight: 1.0 lbs / 0.45 kg



Specifications – Element Size No. 46

Refrigerant	Refrigerant Designation	Orifice Designation	Nominal Capacity (Tons)	Internally Equalized	Externally Equalized	Rainbow Charges™	Inlet Connection (Inches)	Outlet Connection (Inches)	Equalizer Connection (Inches)
R-12 R-134a R-401A R-401B	J	AA A B C D	1/8 to 1/2 1/2 to 1 1 to 2 1-1/2 to 3 3-1/2 to 5	SC-AA-J SC-A-J SC-B-J SC-C-J N/A	SCE-AA-J SCE-A-J SCE-B-J SCE-C-J SCE-D-J	W, X60	3/8 ODF	1/2 ODF	1/4 ODF
R-402B R-404A R-402A R-502 R-507	S	AA A B C D	1/8 to 1/2 1/2 to 1 1-1/2 to 2-1/2 3 to 4 5 to 6	SC-AA-S SC-A-S SC-B-S SC-C-S N/A	SCE-AA-S SCE-A-S SCE-B-S SCE-C-S SCE-D-S	W, Z, X35	3/8 ODF	1/2 ODF	1/4 ODF
R-22 R-407C	V	AA A B C D	1/8 to 1/2 1/2 to 1-1/2 2 to 3 3-1/2 to 5 5 to 6	SC-AA-V SC-A-V SC-B-V SC-C-V N/A	SCE-AA-V SCE-A-V SCE-B-V SCE-C-V SCE-D-V	W, Z, X35, X100	3/8 ODF	1/2 ODF	1/4 ODF

Dimensions – Inches

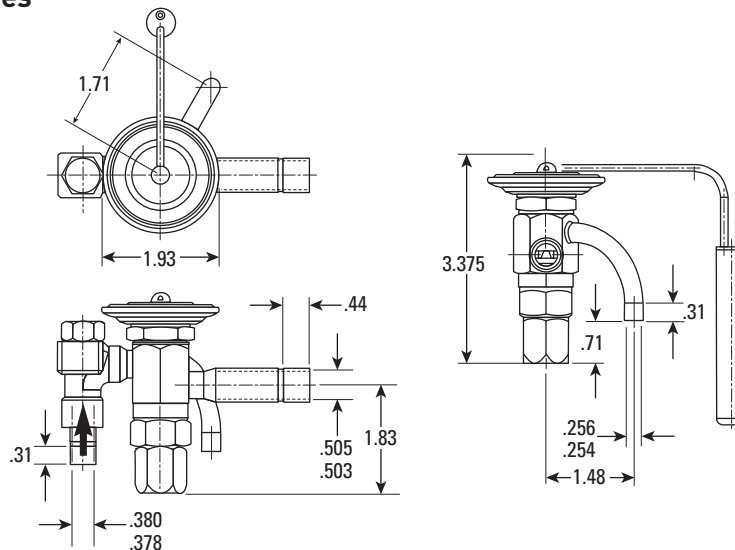

EC(E) Series

The EC(E) series features extended ODF solder connections, brass body and balanced port design. It is suited for both refrigeration and air conditioning applications.

Applications

- Small Chillers
- Heat Pump Units
- Air Conditioning Units
- Freezers
- Walk-in Boxes
- Refrigerated Cases
- Mobile Refrigeration

Features and Benefits

- Extended ODF connections
- Balanced port design
- 60" capillary tube
- Removable power element
- Field adjustable superheat
- 1/4" ODF external equalizer
- Weight: 1.0 lbs / 0.45 kg



Specifications – Element Size No. 46

Refrigerant	Refrigerant Designation	Orifice Designation	Nominal Capacity (Tons)	Internally Equalized	Externally Equalized	Rainbow Charges™	Inlet Connection (Inches)	Outlet Connection Inches (Optional)	Equalizer Connection (Inches)
R-12 R-134a R-401A R-401B	J	AA A B C D	1/8 to 1/2 1/2 to 1 1 to 2 1-1/2 to 3 3-1/2 to 5	EC-AA-J EC-A-J EC-B-J EC-C-J N/A	ECE-AA-J ECE-A-J ECE-B-J ECE-C-J ECE-D-J	W, X60	3/8 ODF (1/2)	1/2 ODF (5/8 ODF) (7/8 ODF)	1/4 ODF
R-402A R-402B R-404A R-502 R-507	S	AA A B C D	1/8 to 1/2 1/2 to 1 1-1/2 to 2-1/2 3 to 4 5 to 6	EC-AA-S EC-A-S EC-B-S EC-C-S N/A	ECE-AA-S ECE-A-S ECE-B-S ECE-C-S ECE-D-S	W, Z, X35	3/8 ODF (1/2)	1/2 ODF (5/8 ODF) (7/8)	1/4 ODF
R-22 R-407C	V	AA A B C D	1/8 to 1/2 1/2 to 1-1/2 2 to 3 3-1/2 to 5 5 to 6	EC-AA-V EC-A-V EC-B-V EC-C-V N/A	ECE-AA-V ECE-A-V ECE-B-V ECE-C-V ECE-D-V	W, Z, X100 X35	3/8 ODF (1/2)	1/2 ODF (5/8 ODF) (7/8)	1/4 ODF

Note: Optional connections not available on all models.

Dimensions – Inches

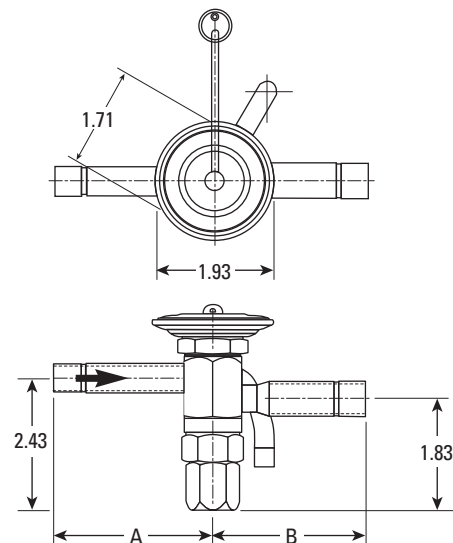

Dimensions (Inches)		
Fitting	Inlet	Outlet
3/8	2.50	—
1/2	2.43	2.50
5/8	2.43	2.50
7/8	—	2.49

H Series and HC Series

The H series balanced port valve is designed specifically for air conditioning and heat pumps used in both air or water source systems. It offers features such as bleed ports and a variety of connection styles for the inlet, outlet and external equalizer.

The HC series adds a built-in 5 ton check valve for R-22, R-407C and R-410A heat pump applications with either factory set or field adjustable superheat.

Applications

- Air Conditioning Systems
- Heat Pump Systems
- Bi-flow (package) Heat Pump Systems

Features and Benefits

- Stainless steel power element
- Bleed ports available
- Bi-directional metering available
- Weight: 10.7 oz. (.30 kg)
- Factory set or field adjustable
- Low pressure drop internal check valve



Specifications

Refrigerant	Refrigerant Designation	Nominal Capacity (Tons)	Internally Equalized	Externally Equalized	Rainbow Charges™	Bleed Port for Off Cycle Operation (Optional)	Inlet Connections (Inches)	Outlet Connections (Inches)		
R-22 R-407C	V	1-1/2	HA 1-1/2V	HAE 1-1/2V	X100	B	1/4, 3/8, 1/2 & 5/8 ODF flo-rater	3/8, 1/2, 5/8 & 7/8 ODF flo-rater		
		3	HA 3V	HAE 3V						
		5	HA 5V	HAE 5V						
		models with internal check valves - "C" designation								
		1-1/2	HCA 1-1/2V	HCAE 1-1/2V	X100	B	1/4, 3/8, 1/2 & 5/8 ODF flo-rater	3/8, 1/2, 5/8 & 7/8 ODF flo-rater		
		3	HCA 3V	HCAE 3V						
5	HCA 5V	HCAE 5V								
R-410A	Z	1-1/2	HA 1-1/2Z	HAE 1-1/2Z	X200	B	1/4, 3/8, 1/2 & 5/8 ODF flo-rater	3/8, 1/2, 5/8 & 7/8 ODF flo-rater		
		3	HA 3Z	HAE 3Z						
		5	HA 5Z	HAE 5Z						
		specific models with internal check valves - "C" designation								
		1-1/2	HCA 1-1/2Z	HCAE 1-1/2Z	X200	B	1/4, 3/8, 1/2 & 5/8 ODF flo-rater	3/8, 1/2, 5/8 & 7/8 ODF flo-rater		
		2	HCA 2Z	HCAE 2Z						
3	HCA 3Z	HCAE 3Z								
5	HCA 5Z	HCAE 5Z								

H Series and HC Series

Dimensions – Inches Connections ODF

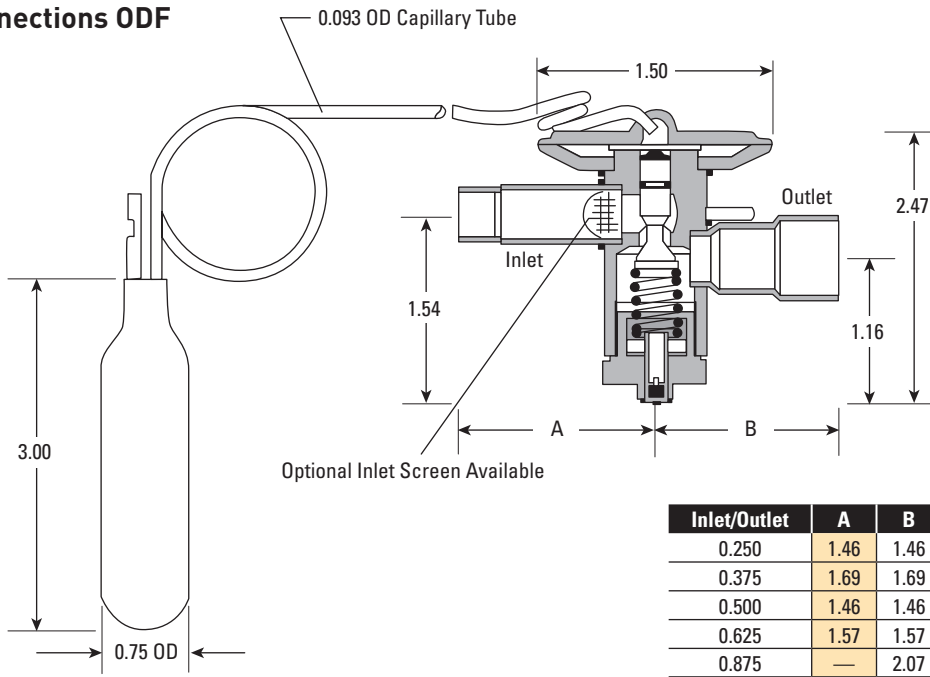

Dimensions – Inches Connections – flo-rater Inlet 3/4" – 20 Outlet 3/4" – 20

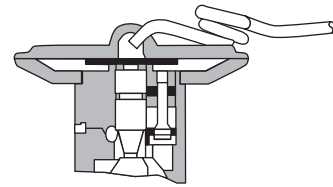
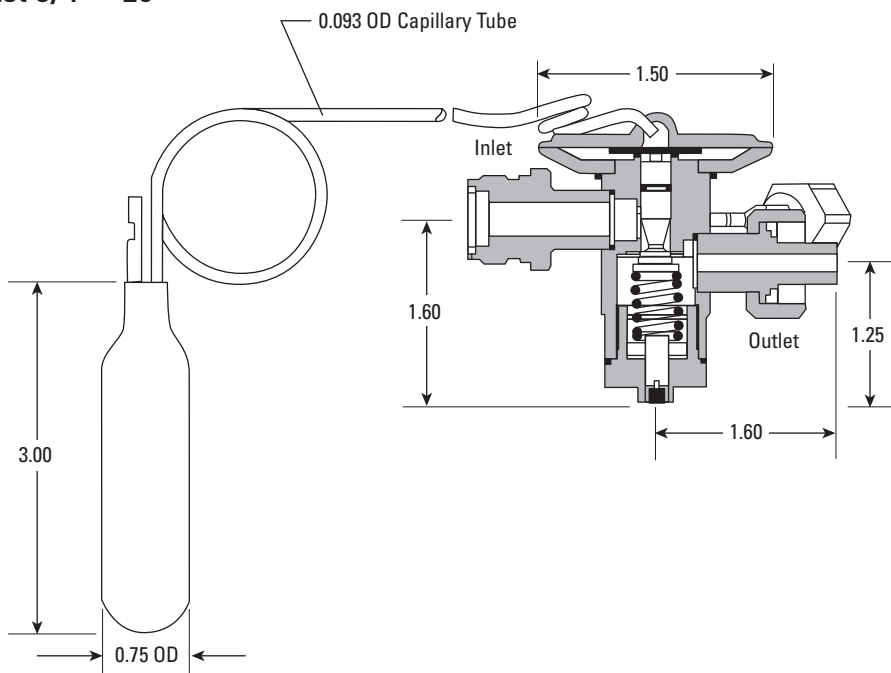

Check valve section
Allows reverse flow in heating mode.

TEV Model Number Selection Guide

Nomenclature (Example) – EBS, OE Valves

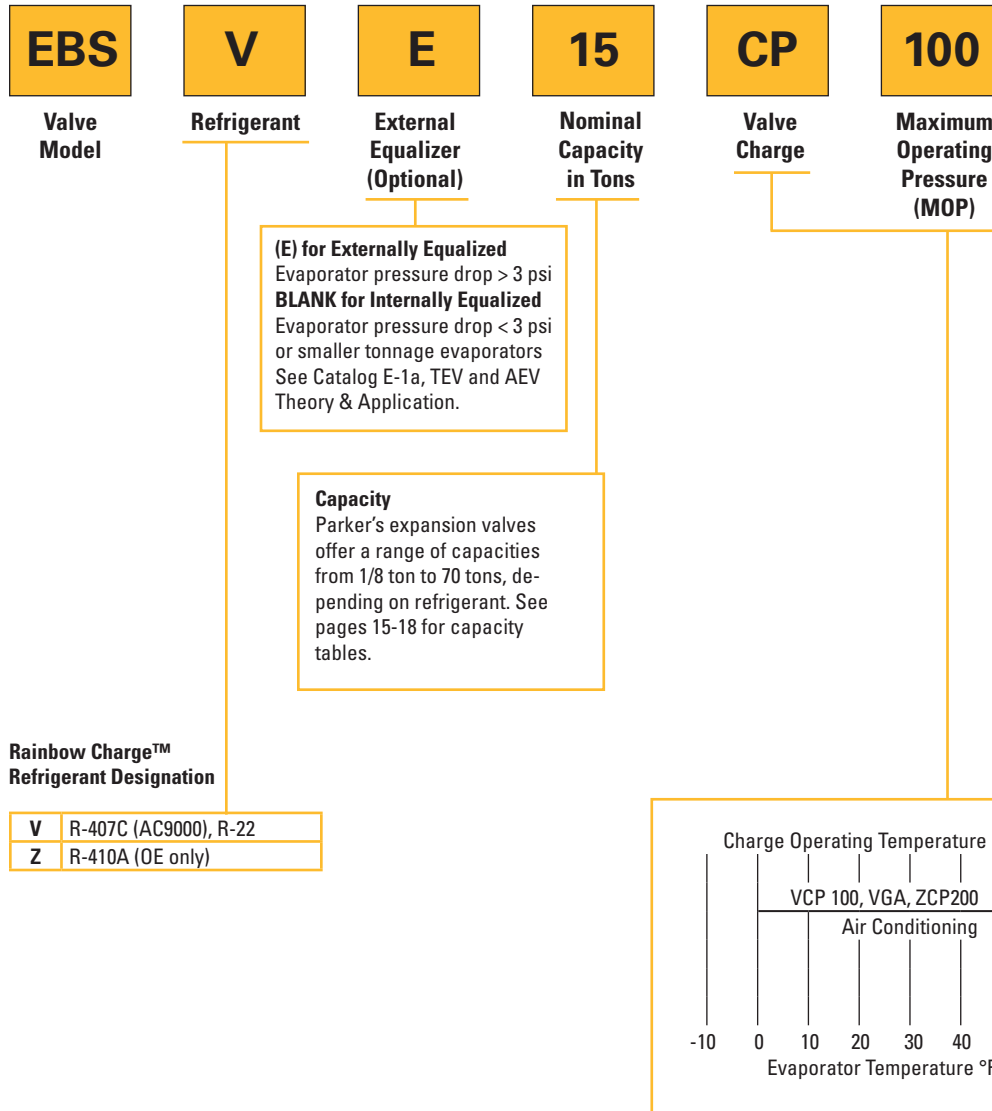

†Charge Type

"W" (all-purpose) liquid charge maintains nearly flat superheat control over a -40°F to +60°F (-40°C to +15°C) evaporator temperature range.

"Z" (low temperature) charge provides fast pulldown benefits like a gas charge with the non-migrating benefits of a liquid charge; usable over a -40°F to 0°F (-40°C to -20°C) evaporator temperature range.

"X" (damped response) gas charge provides a pressure limiting (MOP) charge with anti-hunt characteristics over a -40°F to +60°F (-40°C to +15°C) evaporator temperature range.

Notes: M.O.P. not available on "W" or "Z" charge.

*May not be used on systems in which bulb temperature will exceed 130°F (i.e. defrost). Contact Parker for pressure and temperature.

1. Maximum operational pressure 500 psig (35 bar).
2. Maximum storage temperature 130°F (55°C).
3. Consult Parker for pressure and temperature exceptions.
4. Do not use "W" or "Z" liquid charges in applications where bulb temperatures can exceed 130°F (55°C).
For these applications use type "X" MOP gas charge **only**.

EBS Series

The EBS series valve is a brass bar body valve for R-22 and R-407C. The Type EBS features a balanced port construction and extended ODF connections. The thermostatic element is replaceable. The balanced port construction makes this valve ideally suited for air conditioning applications which operate over widely varying conditions.

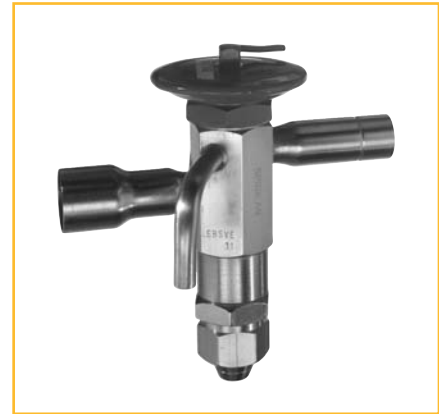

Applications

- Air Conditioning

Features and Benefits

- Balanced port design
- Removable power element
- Field adjustable superheat
- 1/4" sweat external equalizer

Element Size Number 83

Refrigerant	Refrigerant Designation	Type	Thermostatic Charge	Standard Tubing Length (Feet)	Nominal Capacity (Tons)	Connections (Inches) Extended ODF Solder		
		Externally Equalized				Inlet	Outlet	External Equalizer (pointing down parallel to body)
R-22 R-407C	V	EBSVE-8	CP100	5	8	5/8	7/8	1/4
		EBSVE-11			11	5/8	7/8	1/4
		EBSVE-15			15	7/8	1-1/8	1/4
		EBSVE-20			20	7/8	1-3/8	1/4

Dimensions – Inches

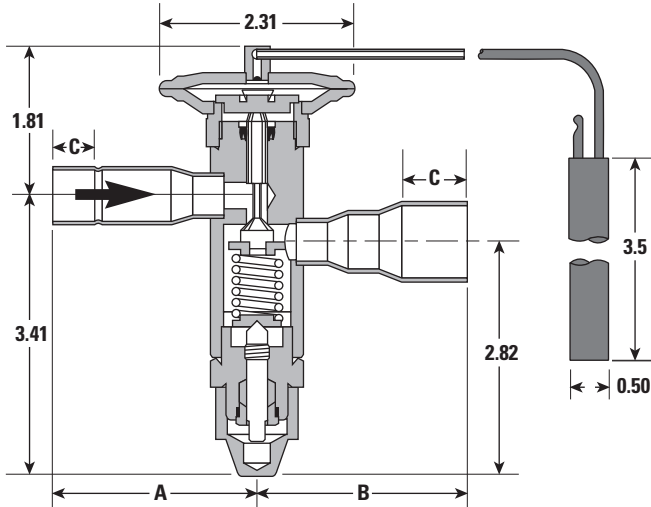

Fitting Size	A	B	C
5/8	2.46	—	.50
7/8	2.46	2.53	.75
1-1/8	—	2.53	.81
1-3/8	—	3.04	.97

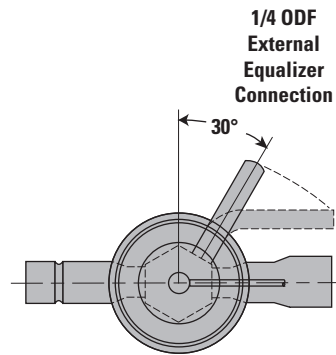

OE Series

The OE series valve utilizes balanced port construction to provide optimum operation on medium to large tonnage air conditioning systems. Two brass body styles with copper ODF connections and a removable thermostatic power element provide the stability and control required in a variety of applications, especially where there are wide changes in load conditions. Body Style 1 has an R-22 nominal capacity up to 30 tons, while Body Style 2 extends the capacity range to 70 tons.



Applications

- Air Conditioning
- Process Chillers

Features and Benefits

- Balanced port design
- Removable power element
- Field adjustable superheat
- 1/4" sweat external equalizer
- Wt: Body Style 1 to 1.7 lbs. / .77 kg Body Style 2 to 2.5 lbs. / 1.13 kg
- 60" capillary tube (120" optional)

Specifications

Element Size Numbers 83, 85, 85-3 and 33, Knife Edge Joint

Refrigerant	Refrigerant Designation	Type	Nominal Capacity (Tons)	Element Size No.	Thermostatic Charges Available	Standard Tubing Length (Feet)	Connections (Inches) ODF Solder		Net Weight (Lbs.)	Shipping Weight (Lbs.)
							Inlet	Outlet		
R-22	V	OVE-15	15	83	CP100	5	7/8	1-1/8	2	3
		OVE-20	20					1-3/8		
		OVE-30	30					1-3/8		
		OVE-40	40	33			1-1/8	1-3/8 or 1-5/8	4	5
		OVE-55	55							
OVE-70	70									
R-410A	Z	OZE-20	20	85	GA	5	7/8	1-1/8	2	3
		OZE-25	25					1-3/8		
		OZE-35	35					1-3/8		
		OZE-50	50	85-3			1-1/8	1-3/8 or 1-5/8	4	5
		OZE-60	60							

Dimensions - Inches

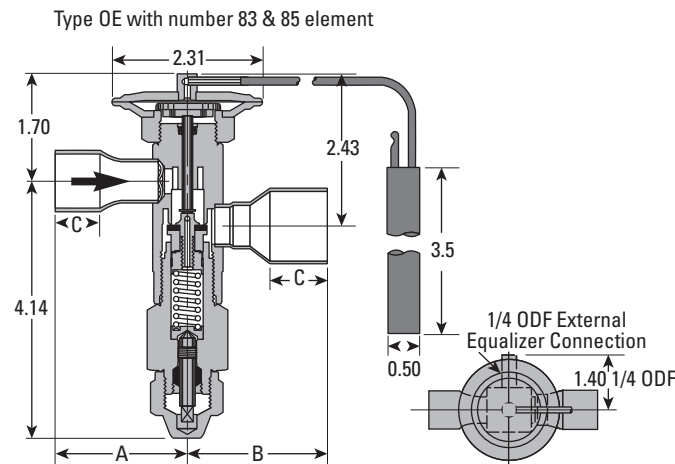

Straight Thru ODF Solder	A	B	C
7/8	2.09	—	0.75
1-1/8	2.21	2.23	0.91
1-3/8	—	2.39	0.97

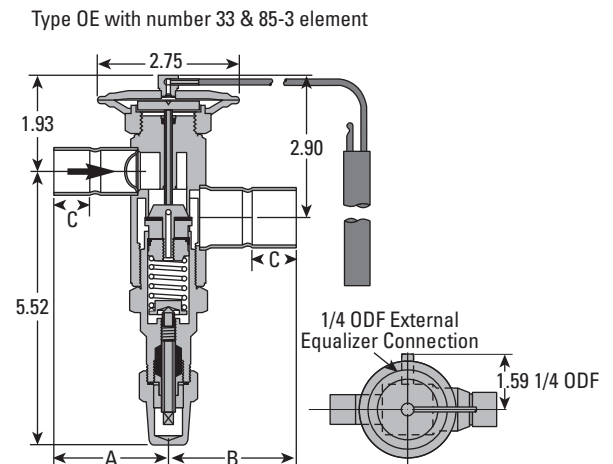

Straight Thru ODF Solder	A	B	C
7/8	2.09	—	0.78
1-1/8	2.69	—	0.91
1-3/8	—	2.84	0.97
1-5/8	—	3.12	1.09

Capacity Tables

R-22 Capacities in Tons (R-407C Refrigerant & Liquid Temperature Correction Factor below)

Valve Type	Orifice	Nominal Capacity (Tons)	Evaporator Temperature°F																							
			40°F								20°F								0°F							
			Pressure Drop (PSI)																							
			75	100	125	150	175	200	225	250	75	100	125	150	175	200	225	250	75	100	125	150	175	200	225	250
HC(E)	---	1-1/2	1.30	1.50	1.68	1.84	1.98	2.12	2.25	2.37	1.27	1.47	1.64	1.80	1.94	2.08	2.21	2.33	1.14	1.32	1.48	1.62	1.75	1.87	1.98	2.09
HC(E)	---	3	2.60	3.00	3.35	3.67	3.97	4.24	4.37	4.48	2.55	2.94	3.29	3.60	3.89	4.16	4.28	4.40	2.29	2.64	2.95	3.23	3.49	3.73	3.84	3.94
HC(E)	---	5	4.33	5.00	5.59	6.12	6.61	7.07	7.17	7.27	4.24	4.90	5.48	6.00	6.48	6.93	7.03	7.13	3.81	4.40	4.92	5.39	5.82	6.22	6.31	6.40
C(E), SC(E), EC(E)	AA	1/2	0.54	0.62	0.69	0.76	0.82	0.88	0.93	0.98	0.52	0.60	0.68	0.74	0.80	0.86	0.91	0.96	0.47	0.54	0.60	0.66	0.72	0.76	0.81	0.85
C(E), SC(E), EC(E)	A	1-1/2	1.52	1.75	1.96	2.14	2.32	2.48	2.36	2.77	1.48	1.71	1.91	2.09	2.26	2.41	2.56	2.70	1.32	1.52	1.70	1.87	2.02	2.16	2.29	2.41
C(E), SC(E), EC(E)	B	3	2.77	3.20	3.58	3.92	4.23	4.53	4.80	5.06	2.70	3.12	3.49	3.82	4.13	4.41	4.68	4.93	2.41	2.79	3.12	3.42	3.69	3.94	4.18	4.41
C(E), SC(E), EC(E)	C	5	4.33	5.00	5.59	6.13	6.62	7.07	7.50	7.91	4.22	4.87	5.45	5.97	6.45	6.89	7.31	7.71	3.77	4.36	4.87	5.34	5.76	6.16	6.54	6.89
C(E), SC(E), EC(E)	D	6	5.20	6.00	6.71	7.35	7.94	8.49	9.00	9.49	5.07	5.85	6.54	7.16	7.74	8.27	8.77	9.25	4.08	4.72	5.27	5.78	6.24	6.67	7.08	7.46
EBS	---	8	7.4	8.5	9.5	10.4	11.2	12.0	12.8	13.4	6.8	7.9	8.8	9.6	10.4	11.1	11.8	12.4	5.7	6.5	7.3	8.0	8.6	9.2	9.8	10.3
EBS	---	11	10.0	11.5	12.9	14.1	15.2	16.3	17.3	18.2	9.2	10.7	11.9	13.0	14.1	15.1	16.0	16.8	7.6	8.8	9.9	10.8	11.7	12.5	13.2	14.0
EBS	---	15	13.4	15.5	17.3	18.9	20.5	21.9	23.2	24.4	12.6	14.6	16.3	17.8	19.3	20.6	21.9	23.0	9.4	10.9	12.2	13.3	14.4	15.4	16.3	17.2
EBS	---	20	19.3	22.3	25.0	27.4	29.5	31.6	33.5	35.3	17.7	20.4	22.8	25.0	27.0	28.9	30.6	32.3	13.1	15.1	16.9	18.5	20.0	21.4	22.7	23.9
OVE	---	15	13.0	15.0	16.8	18.4	19.8	21.2	22.5	23.7	12.0	13.9	15.5	17.0	18.4	19.6	20.8	22.0	10.1	11.7	13.0	14.3	15.4	16.5	17.5	18.4
OVE	---	20	19.2	22.2	24.8	27.2	29.4	31.4	33.3	35.1	17.8	20.6	23.0	25.2	27.2	29.1	30.8	32.5	14.9	17.2	19.3	21.1	22.8	24.4	25.9	27.3
OVE	---	30	26.4	30.5	34.1	37.4	40.4	43.1	45.8	48.2	24.5	28.2	31.6	34.6	37.4	39.9	42.4	44.7	20.5	23.7	26.5	29.0	31.3	33.5	35.5	37.5
OVE	---	40	34.9	40.3	45.1	49.4	53.3	57.0	60.5	63.7	33.7	38.9	43.5	47.6	51.5	55.0	58.3	61.5	24.8	28.6	32.0	35.1	37.9	40.5	42.9	45.6
OVE	---	55	47.6	55.0	61.5	67.4	72.8	77.8	82.5	87.0	46.0	53.1	59.3	65.0	70.2	75.1	79.6	83.9	33.8	39.1	43.7	47.9	51.7	55.3	58.6	61.8
OVE	---	70	63.2	73.0	81.6	89.4	96.6	103	110	115	61.0	70.5	78.8	86.3	93.2	99.6	106	111	44.9	51.9	58.0	63.5	68.6	73.3	77.8	82.0

These ratings are based on vapor free 100°F liquid refrigerant entering the expansion valve, and a maximum of 7°F change in superheat.

Refrigerant	Liquid Temperature Entering TEV							
	0°F	20°F	40°F	60°F	80°F	100°F	120°F	140°F
	Correction Factor							
R-22	1.57	1.45	1.34	1.23	1.12	1.00	0.88	0.76
R-407C	1.58	1.45	1.32	1.18	1.04	0.89	0.74	0.57

These factors include corrections for liquid refrigerant density and net refrigerating effect, and are based on an evaporator temperature of 0°F. However, they may be used for any evaporator temperature from 0°F to 40°F since the variation in the actual factors across this range is insignificant.

TEV Capacity = TEV Rating x CF Liquid Temperature – Example: Actual capacity of an SCE-B using R-407C at a 40°F evaporator, 125 psi pressure drop across the TEV, and a 80°F liquid temperature entering the TEV = 3.58 (from rating chart) x 1.04 (CF liquid temperature) = 3.72 tons

R-22 Capacities in Kilowatts (R-407C Refrigerant & Liquid Temperature Correction Factor below)

Valve Type	Orifice	Nominal Capacity (kW)	Evaporator Temperature°C																							
			5°C								-5°C								-15°C							
			Pressure Drop (BAR)																							
			4	6	8	10	12	14	16	18	4	6	8	10	12	14	16	18	4	6	8	10	12	14	16	18
HC(E)	---	5	4.02	4.92	5.68	6.35	6.96	7.52	8.04	8.52	3.93	4.82	5.56	6.22	6.81	7.36	7.86	8.34	3.57	4.37	5.04	5.64	6.17	6.67	7.13	7.56
HC(E)	---	11	8.04	9.84	11.4	12.7	13.9	15.0	16.1	17.0	7.86	9.63	11.1	12.4	13.6	14.7	15.7	16.7	7.13	8.73	10.1	11.3	12.3	13.3	14.3	15.1
HC(E)	---	18	13.4	16.4	18.9	21.2	23.2	25.1	26.8	28.4	13.1	16.1	18.5	20.7	22.7	24.5	26.2	27.8	11.9	14.6	16.8	18.8	20.6	22.2	23.8	25.2
C(E), SC(E), EC(E)	AA	1.8	1.63	1.99	2.30	2.57	2.82	3.04	3.25	3.45	1.59	1.95	2.25	2.51	2.75	2.97	3.18	3.37	1.45	1.78	2.06	2.30	2.52	2.72	2.91	3.09
C(E), SC(E), EC(E)	A	5.3	4.68	5.74	6.62	7.41	8.11	8.76	9.37	9.94	4.20	5.14	5.93	6.63	7.27	7.85	8.39	8.90	4.20	5.14	5.93	6.63	7.27	7.85	8.39	8.90
C(E), SC(E), EC(E)	B	10.5	8.57	10.5	12.1	13.5	14.8	16.0	17.1	18.2	7.67	9.40	10.8	12.1	13.3	14.4	15.3	16.3	7.67	9.40	10.8	12.1	13.3	14.4	15.3	16.3
C(E), SC(E), EC(E)	C	17.6	13.4	16.4	18.9	21.2	23.2	25.0	26.8	28.4	12.0	14.7	17.0	19.0	20.8	22.4	24.0	25.4	12.0	14.7	17.0	19.0	20.8	22.4	24.0	25.4
C(E), SC(E), EC(E)	D	21.1	16.1	19.7	22.7	25.4	27.8	30.0	32.1	34.1	13.4	16.4	18.9	21.1	23.1	25.0	26.7	28.3	13.4	16.4	18.9	21.1	23.1	25.0	26.7	28.3
EBS	---	28	22.8	27.9	32.3	36.1	39.5	42.7	45.6	48.4	21.3	26.1	30.1	33.7	36.9	39.8	42.6	45.2	18.3	22.4	25.9	29.0	31.7	34.3	36.6	38.9
EBS	---	39	30.9	37.8	43.6	48.8	53.4	57.7	61.7	65.5	28.8	35.3	40.7	45.5	49.9	53.9	57.6	61.1	24.8	30.4	35.0	39.2	42.9	46.4	49.6	52.6
EBS	---	53	41.4	50.8	58.6	65.5	71.8	77.5	82.9	87.9	39.3	48.1	55.6	62.1	68.1	73.5	78.6	83.4	31.5	38.6	44.6	49.9	54.6	59.0	63.1	66.9
EBS	---	70	59.9	73.4	84.8	94.8	104	112	120	127	55.4	67.8	78.3	87.5	95.9	104	111	117	43.9	53.8	62.1	69.4	76.1	82.2	87.8	93.2
OVE	---	53	40.2	49.3	56.9	63.6	69.7	75.3	80.5	85.4	37.6	46.0	53.1	59.4	65.1	70.3	75.1	79.7	32.6	39.9	46.1	51.6	56.5	61.0	65.2	69.2
OVE	---	70	59.6	73.0	84.2	94.2	103	111	119	126	55.6	68.1	78.6	87.9	96.3	104	111	118	48.3	59.1	68.3	76.3	83.6	90.3	96.5	102
OVE	---	105	81.8	100	116	129	142	153	164	174	76.4	93.6	108	121	132	143	153	162	66.3	81.2	93.8	105	115	124	133	141
OVE	---	141	108	132	153	171	187	202	216	229	105	128	148	165	181	196	209	222	83.3	102	118	132	144	156	167	177
OVE	---	193	147	180	208	233	255	276	295	312	143	175	202	226	247	267	285	303	114	139	161	180	197	213	227	241
OVE	---	246	195	239	276	309	339	366	391	415	189	232	268	299	328	354	379	402	151	185	213	238	261	282	302	320

These ratings are based on vapor free 40°C liquid refrigerant entering the expansion valve, and a maximum of 4°C change in superheat.

Refrigerant	Liquid Temperature Entering TEV							
	-10°C	0°C	10°C	20°C	30°C	40°C	50°C	60°C
	Correction Factor							
R-22	1.52	1.42	1.32	1.21	1.11	1.00	0.89	0.78
R-407C	1.53	1.41	1.28	1.15	1.02	0.88	0.74	0.59

These factors include corrections for liquid refrigerant density and net refrigerating effect, and are based on an evaporator temperature of -15°C. However, they may be used for any evaporator temperature from -15°C to 5°C since the variation in the actual factors across this range is insignificant.

TEV Capacity = TEV Rating x CF Liquid Temperature – Example: Actual capacity of an SCE-B using R-407C at a 5°C evaporator, 8 bar pressure drop across the TEV, and a 30°C liquid temperature entering the TEV = 12.1 (from rating chart) x 1.02 (CF liquid temperature) = 12.3 kW

Capacity Tables

R-134a Capacities in Tons (R-401A, R-409A Refrigerant & Liquid Temperature Correction Factor below)

Valve Type	Orifice	Nominal Capacity (Tons)	Evaporator Temperature °F																					
			40°F						20°F						0°F									
			Pressure Drop (PSI)																					
			40	60	80	100	120	140	160	180	40	60	80	100	120	140	160	180	40	60	80	100	120	140
C(E), SC(E), EC(E)	AA	1/2	0.37	0.45	0.52	0.58	0.63	0.68	0.73	0.78	0.85	0.91	0.97	1.03	1.09	1.15	1.21	1.27	1.33	1.39	1.45	1.51	1.57	1.63
C(E), SC(E), EC(E)	A	1	1.03	1.26	1.46	1.63	1.79	1.93	2.06	2.19	2.31	2.43	2.55	2.67	2.79	2.91	3.03	3.15	3.27	3.39	3.51	3.63	3.75	3.87
C(E), SC(E), EC(E)	B	2	1.89	2.31	2.67	2.98	3.27	3.53	3.78	4.00	4.18	4.35	4.52	4.69	4.86	5.03	5.20	5.37	5.54	5.71	5.88	6.05	6.22	6.39
C(E), SC(E), EC(E)	C	2-1/2	2.48	3.03	3.50	3.92	4.29	4.64	4.96	5.26	5.57	5.87	6.16	6.45	6.74	7.03	7.32	7.61	7.90	8.19	8.48	8.77	9.06	9.35
C(E), SC(E), EC(E)	D	4	3.54	4.33	5.01	5.60	6.13	6.62	7.08	7.51	7.93	8.35	8.77	9.18	9.59	10.00	10.41	10.82	11.23	11.64	12.05	12.46	12.87	13.28

These ratings are based on vapor free 100°F liquid refrigerant entering the expansion valve, and a maximum of 7°F change in superheat.

Refrigerant	Liquid Temperature Entering TEV							
	0°F	20°F	40°F	60°F	80°F	100°F	120°F	140°F
	Correction Factor							
R-134a	1.69	1.56	1.42	1.29	1.14	1.00	0.85	0.71
R-401A	1.75	1.62	1.49	1.36	1.23	1.09	0.95	0.81
R-409A	1.65	1.54	1.42	1.31	1.19	1.06	0.94	0.81

These factors include corrections for liquid refrigerant density and net refrigerating effect, and are based on an evaporator temperature of 0°F. However, they may be used for any evaporator temperature from 0°F to 40°F since the variation in the actual factors across this range is insignificant.

TEV Capacity = TEV Rating x CF Liquid Temperature – Example: Actual capacity of an SCE-B using R-409A at a 20°F evaporator, 120 psi pressure drop across the TEV, and a 80°F liquid temperature entering the TEV = 3.12 (from rating chart) x 1.19 (CF liquid temperature) = 3.72 tons

R-134a Capacities in Kilowatts (R-401A, R-409A Refrigerant & Liquid Temperature Correction Factor below)

Valve Type	Orifice	Nominal Capacity (kW)	Evaporator Temperature °C																							
			5°C						-5°C						-15°C											
			Pressure Drop (BAR)																							
			2.5	4.0	5.5	7.0	8.5	10.0	11.5	13.0	2.5	4.0	5.5	7.0	8.5	10.0	11.5	13.0	2.5	4.0	5.5	7.0	8.5	10.0	11.5	13.0
C(E), SC(E), EC(E)	AA	1.8	1.22	1.55	1.82	2.05	2.26	2.45	2.63	2.79	1.17	1.49	1.74	1.97	2.17	2.35	2.52	2.68	1.06	1.34	1.57	1.77	1.95	2.11	2.27	2.41
C(E), SC(E), EC(E)	A	3.5	3.46	4.37	5.12	5.78	6.37	6.91	7.41	7.88	3.32	4.19	4.92	5.55	6.11	6.63	7.11	7.56	2.98	3.77	4.42	4.99	5.50	5.96	6.40	6.80
C(E), SC(E), EC(E)	B	7.0	6.32	7.99	9.37	10.6	11.6	12.6	13.6	14.4	6.06	7.67	8.99	10.1	11.2	12.1	13.0	13.8	5.45	6.90	8.09	9.12	10.1	10.9	11.7	12.4
C(E), SC(E), EC(E)	C	8.8	8.29	10.5	12.3	13.9	15.3	16.6	17.8	18.9	7.96	10.1	11.8	13.3	14.7	15.9	17.1	18.1	7.16	9.05	10.6	12.0	13.2	14.3	15.3	16.3
C(E), SC(E), EC(E)	D	14.1	11.8	15.0	17.6	19.8	21.8	23.7	25.4	27.0	11.4	14.4	16.9	19.0	21.0	22.7	24.4	25.9	9.49	12.0	14.1	15.9	17.5	19.0	20.4	21.6

These ratings are based on vapor free 40°C liquid refrigerant entering the expansion valve, and a maximum of 4°C change in superheat.

Refrigerant	Liquid Temperature Entering TEV							
	-10°C	0°C	10°C	20°C	30°C	40°C	50°C	60°C
	Correction Factor							
R-134a	1.64	1.52	1.39	1.26	1.13	1.00	0.87	0.73
R-401A	1.70	1.59	1.46	1.34	1.22	1.09	0.96	0.83
R-409A	1.61	1.50	1.40	1.29	1.18	1.07	0.95	0.83

These factors include corrections for liquid refrigerant density and net refrigerating effect, and are based on an evaporator temperature of -15°C. However, they may be used for any evaporator temperature from -15°C to 5°C since the variation in the actual factors across this range is insignificant.

TEV Capacity = TEV Rating x CF Liquid Temperature – Example: Actual capacity of an SCE-B using R-409A at a -5°C evaporator, 8.5 bar pressure drop across the TEV, and a 30°C liquid temperature entering the TEV = 11.2 (from rating chart) x 1.18 (CF liquid temperature) = 13.2 kW

Capacity Tables

R-404A Capacities in Tons (R-507 Refrigerant & Liquid Temperature Correction Factor below)

Valve Type	Orifice	Nominal Capacity (Tons)	Evaporator Temperature °F															
			40°F								20°F							
			Pressure Drop (PSI)															
			75	100	125	150	175	200	225	250	75	100	125	150	175	200	225	250
C(E), SC(E), EC(E)	AA	1/2	0.31	0.36	0.40	0.44	0.47	0.50	0.54	0.56	0.29	0.34	0.38	0.41	0.45	0.48	0.51	0.53
C(E), SC(E), EC(E)	A	1	1.00	1.16	1.29	1.42	1.53	1.64	1.74	1.83	0.95	1.10	1.23	1.34	1.45	1.55	1.65	1.73
C(E), SC(E), EC(E)	B	1-1/2	1.32	1.52	1.70	1.86	2.01	2.15	2.28	2.41	1.25	1.44	1.61	1.77	1.91	2.04	2.16	2.28
C(E), SC(E), EC(E)	C	3-1/2	2.86	3.31	3.70	4.05	4.38	4.68	4.96	5.23	2.71	3.13	3.51	3.84	4.15	4.43	4.70	4.96
C(E), SC(E), EC(E)	D	6	4.58	5.29	5.92	6.48	7.00	7.48	7.94	8.37	4.34	5.02	5.61	6.14	6.64	7.09	7.52	7.93

Valve Type	Orifice	Nominal Capacity (Tons)	Evaporator Temperature °F															
			0°F								-10°F							
			Pressure Drop (PSI)															
			75	100	125	150	175	200	225	250	75	100	125	150	175	200	225	250
C(E), SC(E), EC(E)	AA	1/2	0.25	0.29	0.33	0.36	0.39	0.41	0.44	0.46	0.22	0.25	0.28	0.31	0.33	0.36	0.38	0.40
C(E), SC(E), EC(E)	A	1	0.82	0.95	1.06	1.16	1.26	1.34	1.42	1.50	0.53	0.61	0.68	0.75	0.81	0.86	0.91	0.96
C(E), SC(E), EC(E)	B	1-1/2	1.08	1.25	1.40	1.53	1.65	1.77	1.87	1.97	0.71	0.82	0.91	1.00	1.08	1.15	1.22	1.29
C(E), SC(E), EC(E)	C	3-1/2	2.35	2.71	3.03	3.32	3.59	3.84	4.07	4.29	1.48	1.71	1.92	2.10	2.27	2.42	2.57	2.71
C(E), SC(E), EC(E)	D	6	3.76	4.34	4.85	5.31	5.74	6.14	6.51	6.86	1.9	2.2	2.46	2.69	2.91	3.11	3.3	3.48

These ratings are based on vapor free 100°F liquid refrigerant entering the expansion valve, and a maximum of 7°F change in superheat.

Refrigerant	Liquid Temperature Entering TEV							
	0°F	20°F	40°F	60°F	80°F	100°F	120°F	140°F
	Correction Factor							
R-404A	2.04	1.84	1.64	1.43	1.22	1.00	0.77	0.53
R-507	1.95	1.76	1.56	1.37	1.18	0.98	0.76	0.50

These factors include corrections for liquid refrigerant density and net refrigerating effect, and are based on an evaporator temperature of 0°F. However, they may be used for any evaporator temperature from -10°F to 40°F since the variation in the actual factors across this range is insignificant.

TEV Capacity = TEV Rating x CF Liquid Temperature – Example: Actual capacity of an SCE-B using R-507 at a 20°F evaporator, 175 psi pressure drop across the TEV, and a 80°F liquid temperature entering the TEV = 1.91 (from rating chart) x 1.18 (CF liquid temperature) = 2.25 tons

R-404A Capacities in Kilowatts (R-507 Refrigerant & Liquid Temperature Correction Factor below)

Valve Type	Orifice	Nominal Capacity (kW)	Evaporator Temperature °C															
			5°C								-5°C							
			Pressure Drop (BAR)															
			4	6	8	10	12	14	16	18	4	6	8	10	12	14	16	18
C(E), SC(E), EC(E)	AA	1.8	0.95	1.17	1.35	1.51	1.65	1.78	1.91	2.02	0.91	1.11	1.29	1.44	1.57	1.70	1.82	1.93
C(E), SC(E), EC(E)	A	3.5	3.10	3.79	4.38	4.90	5.36	5.79	6.19	6.57	2.95	3.62	4.17	4.67	5.11	5.52	5.90	6.26
C(E), SC(E), EC(E)	B	5.3	4.07	4.98	5.75	6.43	7.05	7.61	8.14	8.63	3.88	4.75	5.49	6.13	6.72	7.26	7.76	8.23
C(E), SC(E), EC(E)	C	12.3	8.85	10.8	12.5	14.0	15.3	16.5	17.7	18.8	8.43	10.3	11.9	13.3	14.6	15.8	16.9	17.9
C(E), SC(E), EC(E)	D	21.1	14.2	17.3	20.0	22.4	24.5	26.5	28.3	30.0	13.5	16.5	19.1	21.3	23.4	25.2	27.0	28.6

Valve Type	Orifice	Nominal Capacity (kW)	Evaporator Temperature °C															
			-15°C								-25°C							
			Pressure Drop (BAR)															
			4	6	8	10	12	14	16	18	4	6	8	10	12	14	16	18
C(E), SC(E), EC(E)	AA	1.8	0.81	0.99	1.15	1.28	1.40	1.52	1.62	1.72	0.65	0.79	0.92	1.03	1.12	1.21	1.30	1.38
C(E), SC(E), EC(E)	A	3.5	2.63	3.22	3.72	4.16	4.55	4.92	5.26	5.58	1.56	1.92	2.21	2.47	2.71	2.93	3.13	3.32
C(E), SC(E), EC(E)	B	5.3	3.46	4.23	4.89	5.46	5.99	6.46	6.91	7.33	2.04	2.49	2.88	3.22	3.53	3.81	4.07	4.32
C(E), SC(E), EC(E)	C	12.3	7.51	9.20	10.6	11.9	13.0	14.1	15.0	15.9	4.40	5.39	6.22	6.96	7.62	8.23	8.80	9.33
C(E), SC(E), EC(E)	D	21.1	12.0	14.7	17.0	19.0	20.8	22.5	24.0	25.5	5.54	6.78	7.83	8.76	9.59	10.4	11.1	11.7

These ratings are based on vapor free 40°C liquid refrigerant entering the expansion valve, and a maximum of 4°C change in superheat.

Refrigerant	Liquid Temperature Entering TEV							
	-10°C	0°C	10°C	20°C	30°C	40°C	50°C	60°C
	Correction Factor							
R-404A	1.98	1.79	1.60	1.41	1.21	1.00	0.79	0.56
R-507	1.89	1.71	1.53	1.35	1.17	0.98	0.78	0.53

These factors include corrections for liquid refrigerant density and net refrigerating effect, and are based on an evaporator temperature of -15°C. However, they may be used for any evaporator temperature from -25°C to 5°C since the variation in the actual factors across this range is insignificant.

TEV Capacity = TEV Rating x CF Liquid Temperature – Example: Actual capacity of an SCE-B using R-507 at a -5°C evaporator, 12 bar pressure drop across the TEV, and a 30°C liquid temperature entering the TEV = 6.72 (from rating chart) x 1.17 (CF liquid temperature) = 7.86 kW

Capacity Tables

R-410A Capacities in Tons

Valve Type	Nominal Capacity (Tons)	Evaporator Temperature °F																	
		40°F						20°F						0°F					
		Pressure Drop (PSI)																	
		120	160	200	240	280	320	120	160	200	240	280	320	120	160	200	240	280	320
HC(E)	1-1/2	1.30	1.50	1.68	1.84	1.98	2.12	1.27	1.47	1.64	1.80	1.94	2.08	1.22	1.41	1.58	1.73	1.87	1.99
HC(E)	3	2.60	3.00	3.35	3.67	3.97	4.24	2.55	2.94	3.29	3.60	3.89	4.16	2.44	2.82	3.15	3.45	3.73	3.99
HC(E)	5	4.33	5.00	5.59	6.12	6.61	7.07	4.24	4.90	5.48	6.00	6.48	6.93	4.07	4.70	5.25	5.76	6.22	6.65
OZE	20	17.1	19.7	22.1	24.2	26.1	27.9	16.7	19.3	21.6	23.7	25.6	27.3	15.8	18.2	20.4	22.3	24.1	25.8
OZE	25	20.5	23.7	26.5	29.0	31.3	33.5	20.1	23.2	25.9	28.4	30.7	32.8	19.0	21.9	24.5	26.8	29.0	31.0
OZE	35	28.2	32.6	36.4	39.9	43.1	46.1	27.6	31.9	35.6	39.0	42.2	45.1	26.1	30.1	33.6	36.9	39.8	42.6
OZE	50	42.7	49.3	55.2	60.4	65.3	69.8	41.8	48.3	54.0	59.1	63.9	68.3	39.5	45.6	51.0	55.8	60.3	64.5
OZE	60	51.3	59.2	66.2	72.5	78.3	83.7	50.2	57.9	64.8	71.0	76.7	82.0	47.4	54.7	61.2	67.0	72.4	77.4

Refrigerant	Liquid Temperature Entering TEV							
	0°F	20°F	40°F	60°F	80°F	100°F	120°F	140°F
	Correction Factor, CF Liquid Temperature							
R-410A	1.79	1.63	1.47	1.32	1.16	1.00	0.83	0.62

These factors include corrections for liquid refrigerant density and net refrigerating effect, and are based on an evaporator temperature of 0°F. However, they may be used for any evaporator temperature from 0°F to 40°F since the variation in the actual factors across this range is insignificant.

TEV Capacity = TEV Rating x CF Liquid Temperature – Example: Actual capacity of an HCE-3 using R-410A at a 40°F evaporator, 160 psi pressure drop across the TEV, and a 80°F liquid temperature entering the TEV = 3.00 (from rating chart) x 1.16 (CF liquid temperature) = 3.48 tons

R-410A Capacities in Kilowatts

Valve Type	Nominal Capacity (kW)	Evaporator Temperature °C																	
		5°C						-5°C						-15°C					
		Pressure Drop (BAR)																	
		8	11	14	17	20	23	8	11	14	17	20	23	8	11	14	17	20	23
HC(E)	5	4.49	5.27	5.94	6.55	6.55	7.62	4.40	5.16	5.82	6.41	6.41	7.46	4.29	5.02	5.67	6.25	6.25	7.27
HC(E)	11	8.98	10.5	11.9	13.1	13.1	15.2	8.80	10.3	11.6	12.8	12.8	14.9	8.57	10.0	11.3	12.5	12.5	14.5
HC(E)	18	15.0	17.6	19.8	21.8	21.8	25.4	14.7	17.2	19.4	21.4	21.4	24.9	14.3	16.7	18.9	20.8	20.8	24.2
OZE	70	59.8	70.1	79.1	87.1	94.5	101	58.5	68.6	77.4	85.2	92.5	99.2	55.7	65.3	73.7	81.2	88.1	94.5
OZE	88	71.7	84.1	94.9	105	113	122	70.2	82.3	92.8	102	111	119	66.9	78.4	88.5	97.5	106	113
OZE	123	98.6	116	130	144	156	167	96.5	113	128	141	153	164	92	108	122	134	145	156
OZE	176	149	175	198	218	236	253	146	171	193	213	231	248	139	163	184	203	220	236
OZE	211	179	210	237	261	284	304	175	206	232	256	277	297	167	196	221	244	264	283

Refrigerant	Liquid Temperature Entering TEV							
	-10°C	0°C	10°C	20°C	30°C	40°C	50°C	60°C
	Correction Factor, CF Liquid Temperature							
R-410A	1.73	1.59	1.44	1.30	1.15	1.00	0.84	0.65

These factors include corrections for liquid refrigerant density and net refrigerating effect, and are based on an evaporator temperature of -15°C. However, they may be used for any evaporator temperature from -15°C to 5°C since the variation in the actual factors across this range is insignificant.

TEV Capacity = TEV Rating x CF Liquid Temperature – Example: Actual capacity of an HCE-3 using R-410A at a 5°C evaporator, 11 bar pressure drop across the TEV, and a 30°C liquid temperature entering the TEV = 10.5 (from rating chart) x 1.15 (CF liquid temperature) = 12.1 kW

A Series Constant Pressure (Automatic) Valves

Specifications

- 0-90 psig adjustment range
- Bypass bleeds available
- Construction: Brass, copper and stainless steel
- Optional external equalizer
- U.L. recognized for maximum operating pressure of 500 psig high side, 225 psig low side

Model No.	Equalizer	Connections (Inches)	
		Inlet	Outlet
A1	Internal	1/4 SAE	1/4 NPTF
A2*	Internal	1/4 SAE	1/2 SAE
A3	Internal	3/8 SAE	1/2 SAE
A4	Internal	1/4 SAE	1/2 SAE
AS	Internal	1/4 ODF	3/8 ODF
A7	Internal	3/8 ODF	3/8 ODF
AT	Internal	1/4 SAE 1/4 ODF 8 mm ODF	1/4 NPTF 8 mm ODF

* 1/2" x 3/8" SAE flare adaptor available.

Model A7

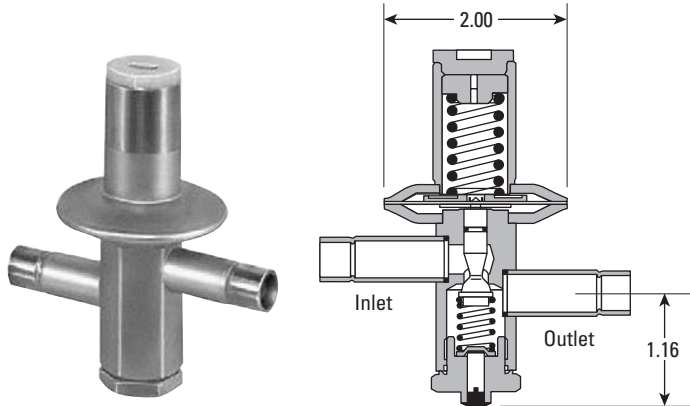

Model AS

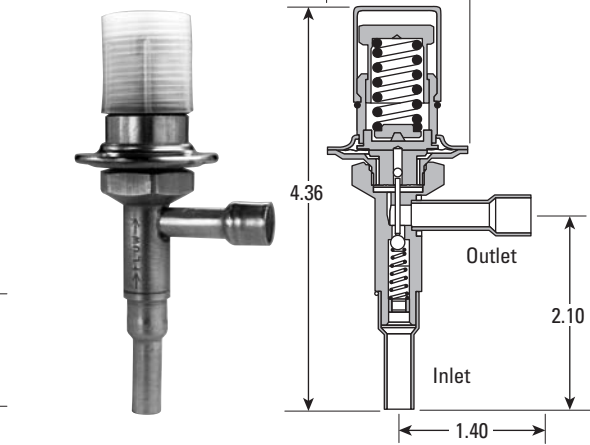

Model AT

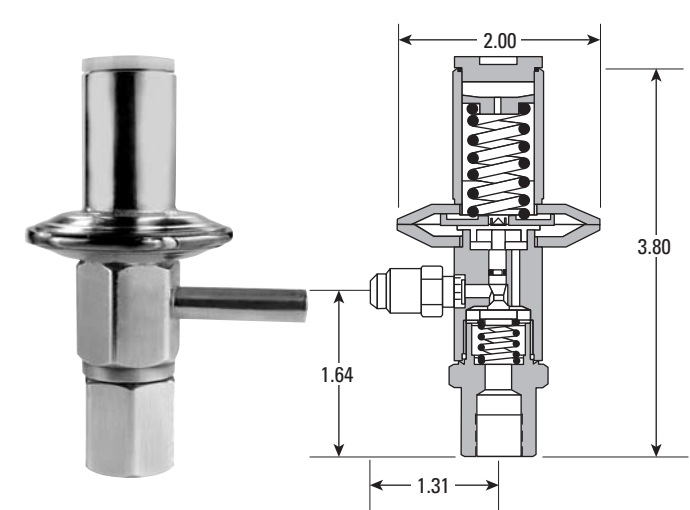

Model A1

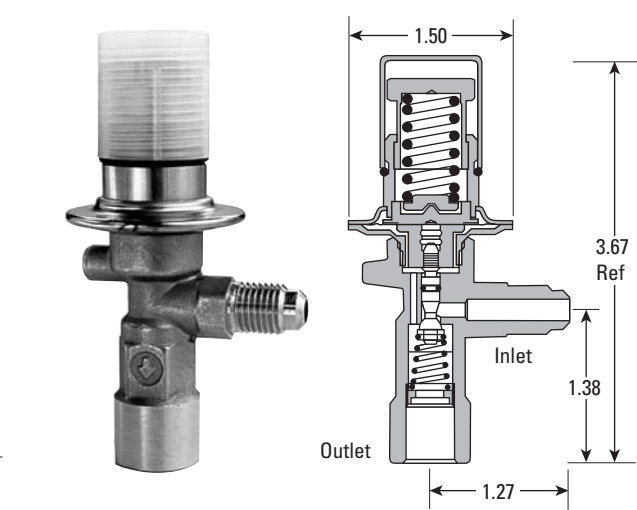

A Series Constant Pressure (Automatic) Valves

Model A2

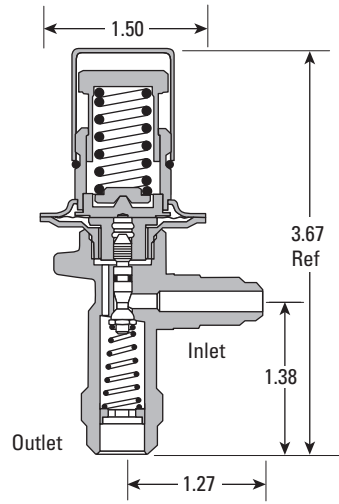

Model A3

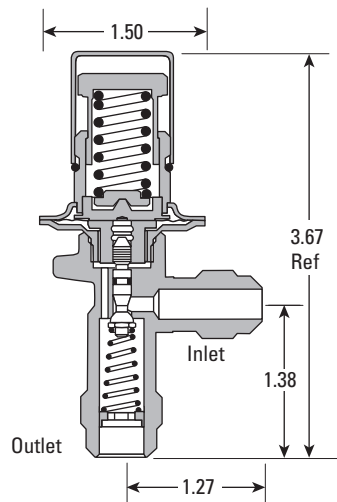

Model A4

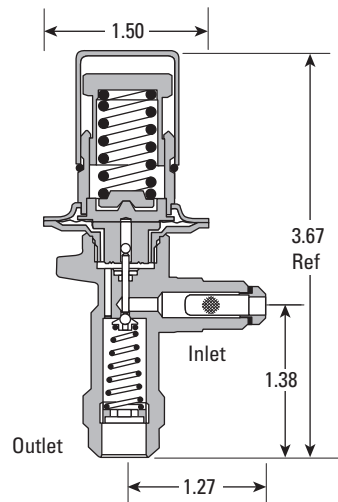

Capacity Tables

R-134a Capacities in Tons (R-401A, R-409A Refrigerant & Liquid Temperature Correction Factor below)

Valve Type	Orifice	Nominal Capacity (Tons)	Capacity Range (Tons)	Evaporator Temperature °F																	
				40°F						20°F						0°F					
				Pressure Drop (PSI)																	
				40	60	80	100	120	140	60	80	100	120	140	160	60	80	100	120	140	160
A1, A2, AT	B	2	1 to 2	1.63	2.00	2.31	2.58	2.83	3.06	1.90	2.19	2.45	2.69	2.90	3.10	1.70	1.96	2.19	2.40	2.60	2.78
A4	—	1/2	1/4 to 3/4	0.61	0.75	0.87	0.97	1.06	1.15	0.71	0.82	0.92	1.01	1.09	1.16	0.64	0.74	0.82	0.90	0.97	1.04
A7-AA	AA	1/2	1/8 to 1/2	0.41	0.50	0.58	0.65	0.71	0.76	0.48	0.55	0.61	0.67	0.73	0.78	0.43	0.49	0.55	0.60	0.65	0.69
A7-A	A	1	1/4 to 1	0.82	1.00	1.15	1.29	1.41	1.53	0.95	1.10	1.23	1.34	1.45	1.55	0.85	0.98	1.10	1.20	1.30	1.39
A7-B	B	2	1 to 2	1.63	2.00	2.31	2.58	2.83	3.06	1.90	2.19	2.45	2.69	2.90	3.10	1.70	1.96	2.19	2.40	2.60	2.78
A7-C	C	3	1-1/2 to 3	2.45	3.00	3.46	3.87	4.24	4.58	2.85	3.29	3.68	4.03	4.35	4.65	2.55	2.94	3.29	3.61	3.90	4.16
AS, ASB20	—	1	1/4 to 1	0.82	1.00	1.15	1.29	1.41	1.53	0.95	1.10	1.23	1.34	1.45	1.55	0.85	0.98	1.10	1.20	1.30	1.39

Valve Type	Orifice	Nominal Capacity (Tons)	Capacity Range (Tons)	Evaporator Temperature °F																	
				-10°F						-20°F						-40°F					
				Pressure Drop (PSI)																	
				80	100	120	140	160	180	80	100	120	140	160	180	80	100	120	140	160	180
A1, A2, AT	B	2	1 to 2	1.64	1.83	2.01	2.17	2.32	2.46	1.34	1.50	1.64	1.77	1.89	2.01	0.88	0.98	1.07	1.16	1.24	1.32
A4	—	1/2	1/4 to 3/4	0.61	0.69	0.75	0.81	0.87	0.92	0.50	0.56	0.62	0.66	0.71	0.75	0.33	0.37	0.40	0.44	0.47	0.49
A7-AA	AA	1/2	1/8 to 1/2	0.41	0.46	0.50	0.54	0.58	0.61	0.33	0.37	0.41	0.44	0.47	0.50	0.22	0.25	0.27	0.29	0.31	0.33
A7-A	A	1	1/4 to 1	0.82	0.92	1.00	1.08	1.16	1.23	0.67	0.75	0.82	0.89	0.95	1.00	0.44	0.49	0.54	0.58	0.62	0.66
A7-B	B	2	1 to 2	1.64	1.83	2.01	2.17	2.32	2.46	1.34	1.50	1.64	1.77	1.89	2.01	0.88	0.98	1.07	1.16	1.24	1.32
A7-C	C	3	1-1/2 to 3	2.46	2.75	3.01	3.25	3.48	3.69	2.01	2.25	2.46	2.66	2.84	3.01	1.32	1.47	1.61	1.74	1.86	1.97
AS, ASB20	—	1	1/4 to 1	0.82	0.92	1.00	1.08	1.16	1.23	0.67	0.75	0.82	0.89	0.95	1.00	0.44	0.49	0.54	0.58	0.62	0.66

Gold areas are standard conditions.

Refrigerant	Liquid Temperature Entering AEV							
	0°F	20°F	40°F	60°F	80°F	100°F	120°F	140°F
	Correction Factor							
R-134a	1.69	1.56	1.42	1.29	1.14	1.00	0.85	0.71
R-401A	1.75	1.62	1.49	1.36	1.23	1.09	0.95	0.81
R-409A	1.65	1.54	1.42	1.31	1.19	1.06	0.94	0.81

These factors include corrections for liquid refrigerant density and net refrigerating effect, and are based on an evaporator temperature of 0°F. However, they may be used for any evaporator temperature from -40°F to 40°F since the variation in the actual factors across this range is insignificant.

AEV Capacity = AEV Rating x CF Liquid Temperature – Example: Actual capacity of an A7-B using R-409A at a 20°F evaporator, 120 psi pressure drop across the AEV, and a 80°F liquid temperature entering the AEV = 2.69 (from rating chart) x 1.19 (CF liquid temperature) = 3.20 tons

R-134a Capacities in Kilowatts (R-401A, R-409A Refrigerant & Liquid Temperature Correction Factor below)

Valve Type	Orifice	Nominal Capacity (kW)	Capacity Range (kW)	Evaporator Temperature °C																	
				10°C						0°C						-10°C					
				Pressure Drop (BAR)																	
				3	4	6	7	8	10	4	6	7	8	10	11	4	6	7	8	10	11
A1, A2, AT	B	7	4 to 7	6.21	7.17	8.79	9.49	10.1	11.3	6.89	8.44	9.11	9.74	10.9	11.4	6.46	7.91	8.54	9.13	10.2	10.7
A4	—	3	1 to 3	2.33	2.69	3.30	3.56	3.80	4.25	2.58	3.16	3.42	3.65	4.08	4.28	2.42	2.97	3.20	3.42	3.83	4.02
A7-AA	AA	2	1/2 to 2	1.55	1.79	2.20	2.37	2.54	2.84	1.72	2.11	2.28	2.44	2.72	2.86	1.61	1.98	2.14	2.28	2.55	2.68
A7-A	A	4	1 to 4	3.11	3.59	4.39	4.75	5.07	5.67	3.44	4.22	4.56	4.87	5.45	5.71	3.23	3.95	4.27	4.57	5.10	5.35
A7-B	B	7	4 to 7	6.21	7.17	8.79	9.49	10.1	11.3	6.89	8.44	9.11	9.74	10.9	11.4	6.46	7.91	8.54	9.13	10.2	10.7
A7-C	C	11	5 to 11	9.32	10.8	13.2	14.2	15.2	17.0	10.3	12.7	13.7	14.6	16.3	17.1	9.69	11.9	12.8	13.7	15.3	16.1
AS, ASB20	—	4	1 to 4	3.11	3.59	4.39	4.75	5.07	5.67	3.44	4.22	4.56	4.87	5.45	5.71	3.23	3.95	4.27	4.57	5.10	5.35

Valve Type	Orifice	Nominal Capacity (kW)	Capacity Range (kW)	Evaporator Temperature °C																	
				-20°C						-30°C						-40°C					
				Pressure Drop (BAR)																	
				6	7	8	10	11	12	6	7	8	10	11	12	6	7	8	10	11	12
A1, A2, AT	B	7	4 to 7	6.77	7.31	7.81	8.74	9.16	9.57	5.01	5.41	5.78	6.47	6.78	7.08	3.25	3.51	3.75	4.20	4.40	4.60
A4	—	3	1 to 3	2.54	2.74	2.93	3.28	3.44	3.59	1.88	2.03	2.17	2.42	2.54	2.66	1.22	1.32	1.41	1.57	1.65	1.72
A7-AA	AA	2	1/2 to 2	1.69	1.83	1.95	2.18	2.29	2.39	1.25	1.35	1.45	1.62	1.70	1.77	0.81	0.88	0.94	1.05	1.10	1.15
A7-A	A	4	1 to 4	3.38	3.65	3.91	4.37	4.58	4.78	2.50	2.70	2.89	3.23	3.39	3.54	1.63	1.76	1.88	2.10	2.20	2.30
A7-B	B	7	4 to 7	6.77	7.31	7.81	8.74	9.16	9.57	5.01	5.41	5.78	6.47	6.78	7.08	3.25	3.51	3.75	4.20	4.40	4.60
A7-C	C	11	5 to 11	10.1	11.0	11.7	13.1	13.7	14.4	7.51	8.11	8.68	9.70	10.2	10.6	4.88	5.27	5.63	6.30	6.60	6.90
AS, ASB20	—	4	1 to 4	3.38	3.65	3.91	4.37	4.58	4.78	2.50	2.70	2.89	3.23	3.39	3.54	1.63	1.76	1.88	2.10	2.20	2.30

Gold areas are standard conditions.

Refrigerant	Liquid Temperature Entering AEV							
	-10°C	0°C	10°C	20°C	30°C	40°C	50°C	60°C
	Correction Factor							
R-134a	1.64	1.52	1.39	1.26	1.13	1.00	0.87	0.73
R-401A	1.70	1.59	1.46	1.34	1.22	1.09	0.96	0.83
R-409A	1.61	1.50	1.40	1.29	1.18	1.07	0.95	0.83

These factors include corrections for liquid refrigerant density and net refrigerating effect, and are based on an evaporator temperature of -15°C. However, they may be used for any evaporator temperature from -40°C to 10°C since the variation in the actual factors across this range is insignificant.

AEV Capacity = AEV Rating x CF Liquid Temperature – Example: Actual capacity of an A7-B using R-409A at a 0°C evaporator, 8 bar pressure drop across the AEV, and a 30°C liquid temperature entering the AEV = 9.74 (from rating chart) x 1.18 (CF liquid temperature) = 11.5 kW

Capacity Tables

R-22 Capacities in Tons (R-407C Refrigerant & Liquid Temperature Correction Factor below)

Valve Type	Orifice	Nominal Capacity (Tons)	Capacity Range (Tons)	Evaporator Temperature °F																	
				40°F				20°F				0°F									
				Pressure Drop (PSI)																	
				75	100	125	150	175	200	75	100	125	150	175	200	75	100	125	150	175	200
A1, A2, AT	B	3	1-1/2 to 3	2.60	3.00	3.35	3.67	3.97	4.24	2.55	2.94	3.29	3.60	3.89	4.16	2.29	2.64	2.95	3.23	3.49	3.73
A4	—	1	1/2 to 1	0.87	1.00	1.12	1.22	1.32	1.41	0.85	0.98	1.10	1.20	1.30	1.39	0.76	0.88	0.98	1.08	1.16	1.24
A7-AA	AA	3/4	1/5 to 3/4	0.65	0.75	0.84	0.92	0.99	1.06	0.64	0.74	0.82	0.90	0.97	1.04	0.57	0.66	0.74	0.81	0.87	0.93
A7-A	A	1-1/2	1/2 to 1-1/2	1.30	1.50	1.68	1.84	1.98	2.12	1.27	1.47	1.64	1.80	1.94	2.08	1.14	1.32	1.48	1.62	1.75	1.87
A7-B	B	3	1-1/2 to 3	2.60	3.00	3.35	3.67	3.97	4.24	2.55	2.94	3.29	3.60	3.89	4.16	2.29	2.64	2.95	3.23	3.49	3.73
A7-C	C	5	3-1/2 to 5	4.33	5.00	5.59	6.12	6.61	7.07	4.24	4.90	5.48	6.00	6.48	6.93	3.81	4.40	4.92	5.39	5.82	6.22
AS, ASB20	—	1-1/2	1/2 to 1-1/2	1.30	1.50	1.68	1.84	1.98	2.12	1.27	1.47	1.64	1.80	1.94	2.08	1.14	1.32	1.48	1.62	1.75	1.87

Valve Type	Orifice	Nominal Capacity (Tons)	Capacity Range (Tons)	Evaporator Temperature °F																	
				-10°F				-20°F				-40°F									
				Pressure Drop (PSI)																	
				100	125	150	175	200	225	125	150	175	200	225	250	125	150	175	200	225	250
A1, A2, AT	B	3	1-1/2 to 3	2.22	2.48	2.72	2.94	3.14	3.33	2.05	2.24	2.42	2.59	2.75	2.89	1.38	1.51	1.63	1.74	1.85	1.94
A4	—	1	1/2 to 1	0.74	0.83	0.91	0.98	1.05	1.11	0.68	0.75	0.81	0.86	0.92	0.96	0.46	0.50	0.54	0.58	0.62	0.65
A7-AA	AA	3/4	1/5 to 3/4	0.56	0.62	0.68	0.73	0.78	0.83	0.51	0.56	0.61	0.65	0.69	0.72	0.34	0.38	0.41	0.43	0.46	0.49
A7-A	A	1-1/2	1/2 to 1-1/2	1.11	1.24	1.36	1.47	1.57	1.67	1.02	1.12	1.21	1.29	1.37	1.45	0.69	0.75	0.81	0.87	0.92	0.97
A7-B	B	3	1-1/2 to 3	2.22	2.48	2.72	2.94	3.14	3.33	2.05	2.24	2.42	2.59	2.75	2.89	1.38	1.51	1.63	1.74	1.85	1.94
A7-C	C	5	3-1/2 to 5	3.70	4.14	4.53	4.89	5.23	5.55	3.41	3.74	4.03	4.31	4.58	4.82	2.29	2.51	2.71	2.90	3.08	3.24
AS, ASB20	—	1-1/2	1/2 to 1-1/2	1.11	1.24	1.36	1.47	1.57	1.67	1.02	1.12	1.21	1.29	1.37	1.45	0.69	0.75	0.81	0.87	0.92	0.97

Gold areas are standard conditions.

Refrigerant	Liquid Temperature Entering AEV							
	0°F	20°F	40°F	60°F	80°F	100°F	120°F	140°F
	Correction Factor							
R-22	1.57	1.45	1.34	1.23	1.12	1.00	0.88	0.76
R-407C	1.58	1.45	1.32	1.18	1.04	0.89	0.74	0.57

These factors include corrections for liquid refrigerant density and net refrigerating effect, and are based on an evaporator temperature of 0°F. However, they may be used for any evaporator temperature from -40°F to 40°F since the variation in the actual factors across this range is insignificant.

AEV Capacity = AEV Rating x CF Liquid Temperature – Example: Actual capacity of an A7-B using R-407C at a 40°F evaporator, 125 psi pressure drop across the AEV, and a 80°F liquid temperature entering the AEV = 3.35 (from rating chart) x 1.04 (CF liquid temperature) = 3.48 tons

R-22 Capacities in Kilowatts (R-407C Refrigerant & Liquid Temperature Correction Factor below)

Valve Type	Orifice	Nominal Capacity (kW)	Capacity Range (kW)	Evaporator Temperature °C																	
				10°C				0°C				-10°C									
				Pressure Drop (BAR)																	
				5	7	9	10	12	14	5	7	9	10	12	14	7	9	10	12	14	16
A1, A2, AT	B	11	5 to 11	9.01	10.7	12.1	12.7	14.0	15.1	8.83	10.4	11.8	12.5	13.7	14.8	10.1	11.5	12.1	13.3	14.3	15.3
A4	—	4	2 to 4	3.00	3.55	4.03	4.25	4.65	5.02	2.94	3.48	3.95	4.16	4.56	4.92	3.37	3.83	4.03	4.42	4.77	5.10
A7-AA	AA	3	3/4 to 3	2.25	2.66	3.02	3.18	3.49	3.77	2.21	2.61	2.96	3.12	3.42	3.69	2.53	2.87	3.03	3.31	3.58	3.83
A7-A	A	5	2 to 5	4.50	5.33	6.04	6.37	6.98	7.54	4.41	5.22	5.92	6.24	6.84	7.38	5.06	5.74	6.05	6.63	7.16	7.65
A7-B	B	11	5 to 11	9.01	10.7	12.1	12.7	14.0	15.1	8.83	10.4	11.8	12.5	13.7	14.8	10.1	11.5	12.1	13.3	14.3	15.3
A7-C	C	18	12 to 18	15.0	17.8	20.1	21.2	23.3	25.1	14.7	17.4	19.7	20.8	22.8	24.6	16.9	19.1	20.2	22.1	23.9	25.5
AS, ASB20	—	5	2 to 5	4.50	5.33	6.04	6.37	6.98	7.54	4.41	5.22	5.92	6.24	6.84	7.38	5.06	5.74	6.05	6.63	7.16	7.65

Valve Type	Orifice	Nominal Capacity (kW)	Capacity Range (kW)	Evaporator Temperature °C																	
				-20°C				-30°C				-40°C									
				Pressure Drop (BAR)																	
				9	10	12	14	16	17	9	10	12	14	16	17	9	10	12	14	16	17
A1, A2, AT	B	11	5 to 11	9.79	10.3	11.3	12.2	13.1	13.5	7.25	7.64	8.37	9.04	9.67	9.96	4.83	5.09	5.58	6.03	6.44	6.64
A4	—	4	2 to 4	3.26	3.44	3.77	4.07	4.35	4.48	2.42	2.55	2.79	3.01	3.22	3.32	1.61	1.70	1.86	2.01	2.15	2.21
A7-AA	AA	3	3/4 to 3	2.45	2.58	2.83	3.05	3.26	3.36	1.81	1.91	2.09	2.26	2.42	2.49	1.21	1.27	1.40	1.51	1.61	1.66
A7-A	A	5	2 to 5	4.89	5.16	5.65	6.10	6.53	6.73	3.63	3.82	4.19	4.52	4.83	4.98	2.42	2.55	2.79	3.01	3.22	3.32
A7-B	B	11	5 to 11	9.79	10.3	11.3	12.2	13.1	13.5	7.25	7.64	8.37	9.04	9.67	9.96	4.83	5.09	5.58	6.03	6.44	6.64
A7-C	C	18	12 to 18	16.3	17.2	18.8	20.3	21.8	22.4	12.1	12.7	14.0	15.1	16.1	16.6	8.06	8.49	9.30	10.0	10.7	11.1
AS, ASB20	—	5	2 to 5	4.89	5.16	5.65	6.10	6.53	6.73	3.63	3.82	4.19	4.52	4.83	4.98	2.42	2.55	2.79	3.01	3.22	3.32

Gold areas are standard conditions.

Refrigerant	Liquid Temperature Entering AEV							
	-10°C	0°C	10°C	20°C	30°C	50°C	60°C	
	Correction Factor							
R-22	1.52	1.42	1.32	1.21	1.11	1.00	0.89	0.78
R-407C	1.53	1.41	1.28	1.15	1.02	0.88	0.74	0.59

These factors include corrections for liquid refrigerant density and net refrigerating effect, and are based on an evaporator temperature of -15°C. However, they may be used for any evaporator temperature from -40°C to 10°C since the variation in the actual factors across this range is insignificant.

AEV Capacity = AEV Rating x CF Liquid Temperature – Example: Actual capacity of an A7-B using R-407C at a 10°C evaporator, 7 bar pressure drop across the AEV, and a 30°C liquid temperature entering the AEV = 10.7 (from rating chart) x 1.02 (CF liquid temperature) = 10.9 kW

Capacity Tables

R-404A Capacities in Tons (R-507 Refrigerant & Liquid Temperature Correction Factor below)

Valve Type	Orifice	Nominal Capacity (Tons)	Capacity Range (Tons)	Evaporator Temperature °F																	
				40°F						20°F						0°F					
				Pressure Drop (PSI)																	
				75	100	125	150	175	200	75	100	125	150	175	200	75	100	125	150	175	200
A1, A2, AT	B	2	1 to 2	1.73	2.00	2.24	2.45	2.65	2.83	1.66	1.92	2.15	2.35	2.54	2.72	1.51	1.74	1.95	2.13	2.30	2.46
A4	—	1/2	1/4 to 3/4	0.65	0.75	0.84	0.92	0.99	1.06	0.62	0.72	0.80	0.88	0.95	1.02	0.57	0.65	0.73	0.80	0.86	0.92
A7-AA	AA	1/2	1/8 to 1/2	0.43	0.50	0.56	0.61	0.66	0.71	0.42	0.48	0.54	0.59	0.63	0.68	0.38	0.44	0.49	0.53	0.58	0.62
A7-A	A	1	1/4 to 1	0.87	1.00	1.12	1.22	1.32	1.41	0.83	0.96	1.07	1.18	1.27	1.36	0.75	0.87	0.97	1.07	1.15	1.23
A7-B	B	2	1 to 2	1.73	2.00	2.24	2.45	2.65	2.83	1.66	1.92	2.15	2.35	2.54	2.72	1.51	1.74	1.95	2.13	2.30	2.46
A7-C	C	4	1-1/2 to 4	3.46	4.00	4.47	4.90	5.29	5.66	3.33	3.84	4.29	4.70	5.08	5.43	3.01	3.48	3.89	4.26	4.60	4.92
AS, ASB20	—	1	1/4 to 1	0.87	1.00	1.12	1.22	1.32	1.41	0.83	0.96	1.07	1.18	1.27	1.36	0.75	0.87	0.97	1.07	1.15	1.23

Valve Type	Orifice	Nominal Capacity (Tons)	Capacity Range (Tons)	Evaporator Temperature °F																	
				-10°F						-20°F						-40°F					
				Pressure Drop (PSI)																	
				100	125	150	175	200	225	125	150	175	200	225	250	125	150	175	200	225	250
A1, A2, AT	B	2	1 to 2	1.48	1.65	1.81	1.96	2.09	2.22	1.36	1.49	1.61	1.73	1.83	1.93	0.87	0.96	1.03	1.10	1.17	1.23
A4	—	1/2	1/4 to 3/4	0.56	0.62	0.68	0.73	0.78	0.83	0.51	0.56	0.61	0.65	0.69	0.72	0.33	0.36	0.39	0.41	0.44	0.46
A7-AA	AA	1/2	1/8 to 1/2	0.37	0.41	0.45	0.49	0.52	0.56	0.34	0.37	0.40	0.43	0.46	0.48	0.22	0.24	0.26	0.28	0.29	0.31
A7-A	A	1	1/4 to 1	0.74	0.83	0.91	0.98	1.05	1.11	0.68	0.75	0.81	0.86	0.92	0.96	0.44	0.48	0.52	0.55	0.59	0.62
A7-B	B	2	1 to 2	1.48	1.65	1.81	1.96	2.09	2.22	1.36	1.49	1.61	1.73	1.83	1.93	0.87	0.96	1.03	1.10	1.17	1.23
A7-C	C	4	1-1/2 to 4	2.96	3.31	3.63	3.92	4.19	4.44	2.73	2.99	3.23	3.45	3.66	3.86	1.74	1.91	2.06	2.21	2.34	2.47
AS, ASB20	—	1	1/4 to 1	0.74	0.83	0.91	0.98	1.05	1.11	0.68	0.75	0.81	0.86	0.92	0.96	0.44	0.48	0.52	0.55	0.59	0.62

Gold areas are standard conditions.

Refrigerant	Liquid Temperature Entering AEV							
	0°F	20°F	40°F	60°F	80°F	100°F	120°F	140°F
	Correction Factor							
R-404A	2.04	1.84	1.64	1.43	1.22	1.00	0.77	0.53
R-507	1.95	1.76	1.56	1.37	1.18	0.98	0.76	0.50

These factors include corrections for liquid refrigerant density and net refrigerating effect, and are based on an evaporator temperature of 0°F. However, they may be used for any evaporator temperature from -40°F to 40°F since the variation in the actual factors across this range is insignificant.

AEV Capacity = AEV Rating x CF Liquid Temperature – Example: Actual capacity of an A7-B using R-507 at a 20°F evaporator, 175 psi pressure drop across the AEV, and a 80°F liquid temperature entering the AEV = 2.54 (from rating chart) x 1.18 (CF liquid temperature) = 3.00 tons

R-404A Capacities in Kilowatts (R-507 Refrigerant & Liquid Temperature Correction Factor below)

Valve Type	Orifice	Nominal Capacity (kW)	Capacity Range (kW)	Evaporator Temperature °C																	
				10°C						0°C						-10°C					
				Pressure Drop (BAR)																	
				5	7	9	10	12	14	5	7	9	10	12	14	5	7	9	10	12	14
A1, A2, AT	B	7	4 to 7	6.06	7.17	8.14	8.58	9.39	10.1	5.88	6.96	7.89	8.32	9.11	9.84	5.58	6.60	7.48	7.89	8.64	9.33
A4	—	3	1 to 3	2.27	2.69	3.05	3.22	3.52	3.80	2.21	2.61	2.96	3.12	3.42	3.69	2.09	2.48	2.81	2.96	3.24	3.50
A7-AA	AA	2	1/2 to 2	1.52	1.79	2.03	2.14	2.35	2.54	1.47	1.74	1.97	2.08	2.28	2.46	1.39	1.65	1.87	1.97	2.16	2.33
A7-A	A	4	1 to 4	3.03	3.59	4.07	4.29	4.70	5.07	2.94	3.48	3.95	4.16	4.56	4.92	2.79	3.30	3.74	3.94	4.32	4.67
A7-B	B	7	4 to 7	6.06	7.17	8.14	8.58	9.39	10.1	5.88	6.96	7.89	8.32	9.11	9.84	5.58	6.60	7.48	7.89	8.64	9.33
A7-C	C	14	5 to 14	12.1	14.3	16.3	17.2	18.8	20.3	11.8	13.9	15.8	16.6	18.2	19.7	11.2	13.2	15.0	15.8	17.3	18.7
AS, ASB20	—	4	1 to 4	3.03	3.59	4.07	4.29	4.70	5.07	2.94	3.48	3.95	4.16	4.56	4.92	2.79	3.30	3.74	3.94	4.32	4.67

Valve Type	Orifice	Nominal Capacity (kW)	Capacity Range (kW)	Evaporator Temperature °C																	
				-20°C						-30°C						-40°C					
				Pressure Drop (BAR)																	
				7	9	10	12	14	16	9	10	12	14	16	17	9	10	12	14	16	17
A1, A2, AT	B	7	4 to 7	5.67	6.43	6.77	7.42	8.02	8.57	4.80	5.06	5.54	5.99	6.40	6.60	3.09	3.26	3.57	3.86	4.12	4.25
A4	—	3	1 to 3	2.13	2.41	2.54	2.78	3.01	3.21	1.80	1.90	2.08	2.24	2.40	2.47	1.16	1.22	1.34	1.45	1.55	1.59
A7-AA	AA	2	1/2 to 2	1.42	1.61	1.69	1.86	2.00	2.14	1.20	1.26	1.39	1.50	1.60	1.65	0.77	0.81	0.89	0.96	1.03	1.06
A7-A	A	4	1 to 4	2.83	3.21	3.39	3.71	4.01	4.28	2.40	2.53	2.77	2.99	3.20	3.30	1.55	1.63	1.78	1.93	2.06	2.12
A7-B	B	7	4 to 7	5.67	6.43	6.77	7.42	8.02	8.57	4.80	5.06	5.54	5.99	6.40	6.60	3.09	3.26	3.57	3.86	4.12	4.25
A7-C	C	14	5 to 14	11.3	12.9	13.5	14.8	16.0	17.1	9.60	10.1	11.1	12.0	12.8	13.2	6.18	6.52	7.14	7.71	8.24	8.50
AS, ASB20	—	4	1 to 4	2.83	3.21	3.39	3.71	4.01	4.28	2.40	2.53	2.77	2.99	3.20	3.30	1.55	1.63	1.78	1.93	2.06	2.12

Gold areas are standard conditions.

Refrigerant	Liquid Temperature Entering AEV							
	-10°C	0°C	10°C	20°C	30°C	40°C	50°C	60°C
	Correction Factor							
R-404A	1.98	1.79	1.60	1.41	1.21	1.00	0.79	0.56
R-507	1.89	1.71	1.53	1.35	1.17	0.98	0.78	0.53

These factors include corrections for liquid refrigerant density and net refrigerating effect, and are based on an evaporator temperature of -15°C. However, they may be used for any evaporator temperature from -40°C to 10°C since the variation in the actual factors across this range is insignificant.

AEV Capacity = AEV Rating x CF Liquid Temperature – Example: Actual capacity of an A7-B using R-507 at a 0°C evaporator, 12 bar pressure drop across the AEV, and a 30°C liquid temperature entering the AEV = 9.11 (from rating chart) x 1.17 (CF liquid temperature) = 10.7 kW



CLIMATE CONTROL

- Accumulators
- CO₂ controls
- Electronic controllers
- Filter-driers
- Hand shut-off valves
- Heat exchangers
- Hose & fittings
- Pressure regulating valves
- Refrigerant distributors
- Safety relief valves
- Solenoid valves
- Thermostatic expansion valves



AEROSPACE

- Flight control systems & components
- Fluid conveyance systems
- Fluid metering delivery & atomization devices
- Fuel systems & components
- Hydraulic systems & components
- Inert nitrogen generating systems
- Pneumatic systems & components
- Wheels & brakes



ELECTROMECHANICAL

- AC/DC drives & systems
- Electric actuators, gantry robots & slides
- Electrohydrostatic actuation systems
- Electromechanical actuation systems
- Human machine interfaces
- Linear motors
- Stepper motors, servo motors, drives & controls
- Structural extrusions



FILTRATION

- Analytical gas generators
- Compressed air & gas filters
- Condition monitoring
- Engine air, fuel & oil filtration & systems
- Hydraulic, lubrication & coolant filters
- Process, chemical, water & microfiltration filters
- Nitrogen, hydrogen & zero air generators



FLUID & GAS HANDLING

- Brass fittings & valves
- Diagnostic equipment
- Fluid conveyance systems
- Industrial hose
- PTFE & PFA hose, tubing & plastic fittings
- Quick disconnects
- Rubber & thermoplastic hose & couplings
- Tube fittings & adapters



HYDRAULICS

- Diagnostic equipment
- Hydraulic cylinders & accumulators
- Hydraulic motors & pumps
- Hydraulic systems
- Hydraulic valves & controls
- Power take-offs
- Quick disconnects
- Rubber & thermoplastic hose & couplings
- Tube fittings & adapters



PNEUMATICS

- Air preparation
- Brass fittings & valves
- Manifolds
- Pneumatic actuators, grippers, valves, controls & accessories
- Quick disconnects
- Rotary actuators
- Rubber & thermoplastic hose & couplings
- Structural extrusions
- Thermoplastic tubing & fittings
- Vacuum generators, cups & sensors



PROCESS CONTROL

- Analytical sample conditioning products & systems
- Fluoropolymer chemical delivery fittings, valves & pumps
- High purity gas delivery fittings, valves & regulators
- Instrumentation fittings, valves & regulators
- Medium pressure fittings & valves
- Process control manifolds



SEALING & SHIELDING

- Dynamic seals
- Elastomeric o-rings
- EMI shielding
- Extruded & precision-cut, fabricated elastomeric seals
- Homogeneous & inserted elastomeric shapes
- High temperature metal seals
- Metal & plastic retained composite seals
- Thermal management

Parker Hannifin Corporation
Climate and Industrial Controls Group
 2445 South 25th Avenue • Broadview, IL 60155-3891 USA
 phone 800 742 2681 • fax 800 241 2872
www.parker.com/coolparts

102007 / Catalog E-1

