

Climate 5000 Series 30K BTU Single Zone Light Commercial System Wall Mounted IDU

Engineering
Submittal
Sheet



BOSCH

Overview and Project Information



Project Name	
Location	
Architect	
Engineer	
General Contractor	
Reference #	

30K Btu Single Zone Light Commercial System - Wall Mounted IDU

Indoor model #	8733953098	
Indoor model name	BMS500-AAS030-1AHWXB	
Outdoor model #	8733953099	
Outdoor model name	BMS500-AAS030-1CSXRB	
Performance Data		
Cooling	Capacity (Btu/h):	30000
	Input (W)	2605
	Rated current (A)	11.5
	EER (Btu/w)	11.5
	SEER (Btu/w)	19.8
Heating at 47°F	Capacity (Btu/h)	30000
	Input (W)	3410
	Rated current (A)	15
	COP (W/W)	2.58
	HSPF4	9.4
	HSPF5	8
Electrical Data		
Power supply (V / Ø / Hz)	208-230 / 1 / 60	
Min. Circuit ampacity (A)	20.0	
Max. Fuse (A)	30.0	
Compressor Data		
Type:	Twin-Rotary	
Refrigerant oil /oil charge (ml)	ESTER OIL VG74/670	
Input (W)	1970	
Rated current (RLA / A)	14.00	
Piping		
Refrigerant Charge (oz/g)	90.7 / 2750	
Liquid side (in/mm)	3/8" / Ø9.52	
Gas side (in/mm)	5/8" / Ø15.9	
Additional charge per ft (oz)	0.32	
Refrigerant precharge (ft/m)	25 / 7.6	
Max. refrigerant pipe length (ft/m)	164 / 50	
Max. difference in height (ft/m)	82 / 25	

Operation Range

ODU	Cooling (°F / °C)	5~122 / -15~50
	Heating (°F / °C)	5~86 / -15~30
IDU	Cooling (°F / °C)	62~90 / 17~32
	Heating (°F / °C)	32~86 / 0~30

System Data

Refrigerant Type		R410A
Design pressure (PSIG)		550/340
Dehumidification (pts/hr)		6.75
IDU	Fan motor qty (ea)	1
	Fan motor input (W)	72.0
	Fan motor RLA (A)	0.23
	Fan speed (RPM)	1200 / 1100 / 900
	Air flow, H / M / L (CFM)	794 / 647 / 500
	Noise level, H / M / L (dB(A))	48.5 / 44 / 38
	Net weight (lbs / kg)	39.9 / 18.1
	Gross weight (lbs / kg)	53.6 / 24.3
ODU	Fan motor qty (ea)	1
	Fan motor input (W)	150
	Fan motor RLA (A)	0.50
	Fan motor speed (RPM)	810 / 700 / 500
	Air flow, Max (CFM)	2353
	Noise level, Max (dB(A))	59.0
	Net weight (lbs / kg)	135.6 / 61.5
	Gross weight (lbs / kg)	148.8 / 67.5
Accessories		
BMS-WT1-XXX (8733953127)	Wired Wall Thermostat	
BMS-DRY-XXX (8733953129)	24V Interface	
BMS-PK3-7X1 (8733951015)	25ft Lineset	
BMS-PK3-5X1 (8733951018)	16ft Lineset	

Climate 5000 Series

30K Btu Single Zone Light Commercial System - Wall Mounted IDU



BOSCH

Indoor Unit Dimensions and Connections

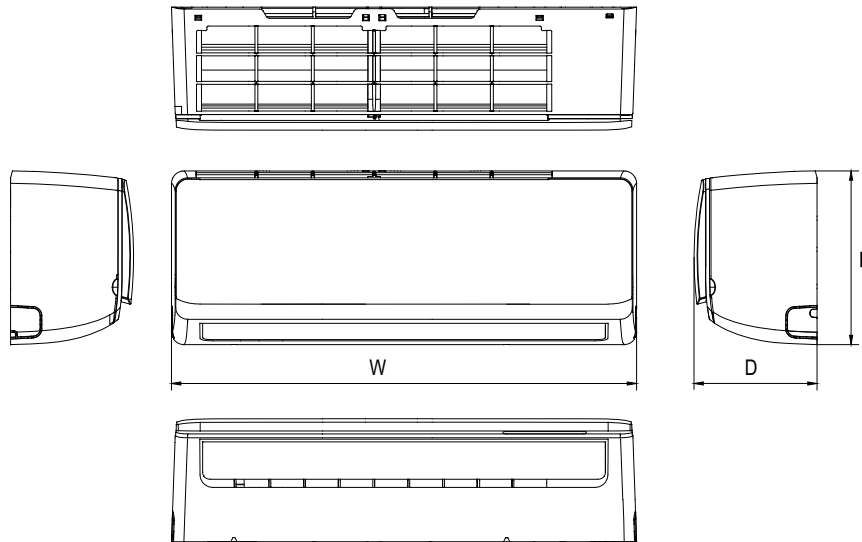

Model	W (in)	D (in)	H (in)
BMS500-AAS030-1AHWXB	46.7	10.2	13.4

Outdoor Unit Dimensions and Connections

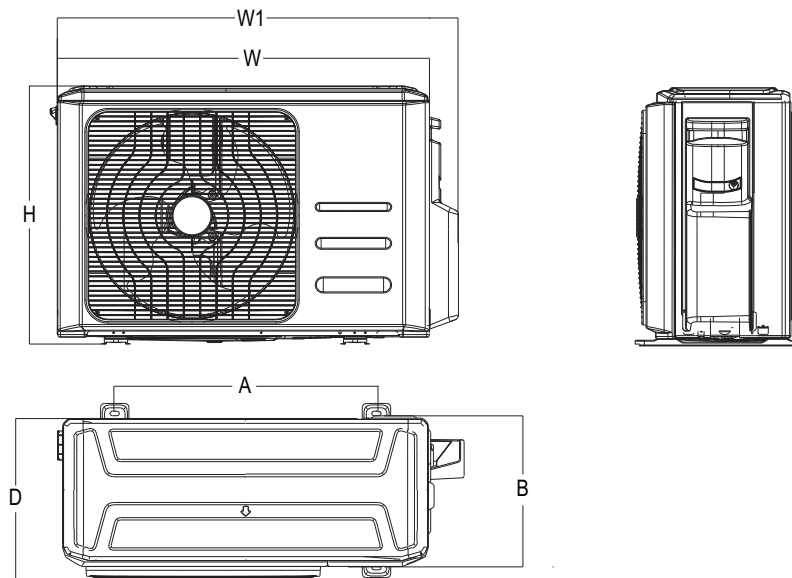

Model	W (in)	D (in)	H (in)	W1 (in)	A (in)	B (in)
BMS500-AAS030-1CSXRB	37.2	16.1	31.9	40.6	26.5	15.9