



# BOSCH

Installation Instructions

## Split System Heat Pump

### Bosch BCA Series

Ceiling Mounted Air Handler Units | 1.5-3 Ton Capacity | R410A

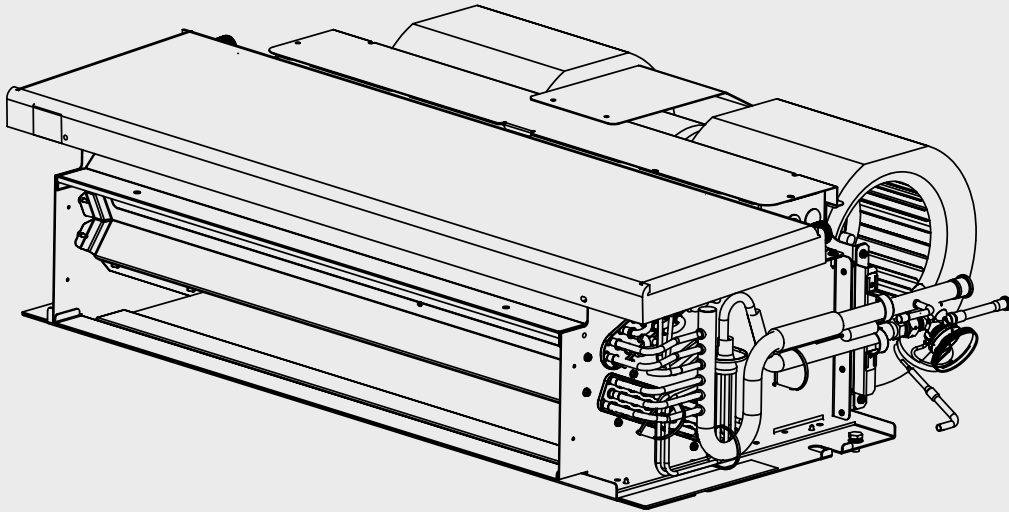

BTC 761703106 A / 03.2023





**Table of Contents**

<b>1 Key to Symbols and Safety Instructions</b>	<b>4</b>
1.1 Key to Symbols	4
1.2 Safety	4
<b>2 General</b>	<b>5</b>
<b>3 Dimensional Data</b>	<b>6</b>
3.1 Uncased Unit Dimensions	6
3.2 Cased Unit Dimensions	7
<b>4 Mounting</b>	<b>8</b>
<b>5 Electrical wiring</b>	<b>8</b>
5.1 Power Wiring	8
5.2 Control Wiring	8
5.3 Grounding	8
5.4 Electrical Data	8
<b>6 Airflow Performance</b>	<b>9</b>
6.1 Uncased Unit	9
6.2 Cased Unit	10
6.3 Required Airflow Range for Normal Operation	11
<b>7 Ductwork</b>	<b>12</b>
<b>8 Refrigerant Connections</b>	<b>13</b>
8.1 Condensate Drain Connection	13
<b>9 Air Filter (Not Factory-Installed)</b>	<b>14</b>
<b>10 Maintenance</b>	<b>15</b>
10.1 Cleaning Precautions	15
10.2 Regular Maintenance	15
<b>11 Wiring Diagrams</b>	<b>16</b>
11.1 Unit Wiring	17

# 1 Key to Symbols and Safety Instructions

## 1.1 Key to Symbols

### Warnings

	<p>Warnings in this document are identified by a warning triangle printed against a grey background.</p> <p>Keywords at the start of a warning indicate the type and seriousness of the ensuing risk if measures to prevent the risk are not taken.</p>
--	---

The following keywords are defined and can be used in this document:

- ▶ **DANGER:** indicates a hazardous situation which, if not avoided, will result in death or serious injury.
- ▶ **WARNING:** indicates a hazardous situation which, if not avoided, could result in death or serious injury.
- ▶ **CAUTION:** indicates a hazardous situation which, if not avoided, could result in minor to moderate injury.
- ▶ **NOTICE:** is used to address practices not related to personal injury.

### Important information

	<p>This symbol indicates important information where there is no risk to people or property.</p>
--	--

## 1.2 Safety

Please read before proceeding

	<p><b>WARNING:</b></p> <p>These instructions are intended as an aid to qualified, licensed service personnel for proper installation, adjustment and operation of this unit. Read these instructions thoroughly before attempting installation or operation. Failure to follow these instruction may lead to improper installation, adjustment, service or maintenance possibly resulting in fire, electrical shock, property damage, personal injury or death.</p>
--	---

	<p>This document is customer property and is to remain with this unit. These instructions do not cover all the different variations of systems nor does it provide for every possible contingency to be met in connection with installation.</p>
--	--

	<p><b>WARNING: FIRE, ELECTRICAL SHOCK, PROPERTY DAMAGE, PERSONAL INJURY, OR DEATH</b></p> <p>All phases of this installation must comply with NATIONAL, STATE AND LOCAL CODES. If additional information is required please contact your local distributor.</p>
--	---

	<p><b>WARNING: ELECTRICAL SHOCK</b></p> <p>Disconnect all power to unit before installing or servicing. More than one disconnect switch may be required to deenergize the equipment. Hazardous voltage can cause severe personal injury or death.</p>
--	---

	<p><b>WARNING: ELECTRICAL SHOCK</b></p> <p>If removal of the blower assembly is required, all disconnect switches supplying power to the equipment must be deenergized and locked (if not in sight of unit) so the field power wires can be safely removed from the blower assembly. Failure to do so can cause electrical shock resulting in personal injury or death.</p>
--	---

	<p><b>WARNING: FIRE, ELECTRICAL SHOCK, PROPERTY DAMAGE, PERSONAL INJURY, OR DEATH</b></p> <p>Because of possible damage to equipment or personal injury, installation, service, and maintenance should be performed by trained, qualified service personnel. Consumer service is recommended only for filter cleaning / replacement. Never operate the unit with the access panels removed.</p>
--	---

**WARNING:**

This product can expose you to chemicals including Lead and Lead components, which are known to the State of California to cause cancer and birth defects or other reproductive harm. For more information go to [www.P65Warnings.ca.gov](http://www.P65Warnings.ca.gov).

**WARNING: ELECTRICAL SHOCK**

The unit must be permanently grounded. Failure to do so can result in electrical shock causing personal injury or death.

**CAUTION: FIRE HAZARD**

The material of plenum and ductwork must meet the latest edition of the NFPA 90B standard.

## 2 General

The unit is designed for horizontal orientation and is suitable for ceiling installations in conditioned space and are paired with IDS Light Condensers. The units have a factory-installed TXV and are available in 18,000 through 36,000 Btuh nominal cooling capacities.

The unit is equipped with sweat-type connections and is vapor-charged with dry nitrogen. Units are designed for horizontal applications only. Local codes may limit this free-air-return type unit to installation in single-level applications.

**NOTICE:**

The installed unit must have the required clearances as shown in Section 3. Failure to follow these instructions may result in equipment damage and/or premature equipment failure.

**WARNING: FIRE HAZARD**

Keep flammable material and vapors, such as gasoline, away from the air handler. Failure to follow these instructions can result in death, explosion, or fire.

### 3 Dimensional Data

#### 3.1 Uncased Unit Dimensions

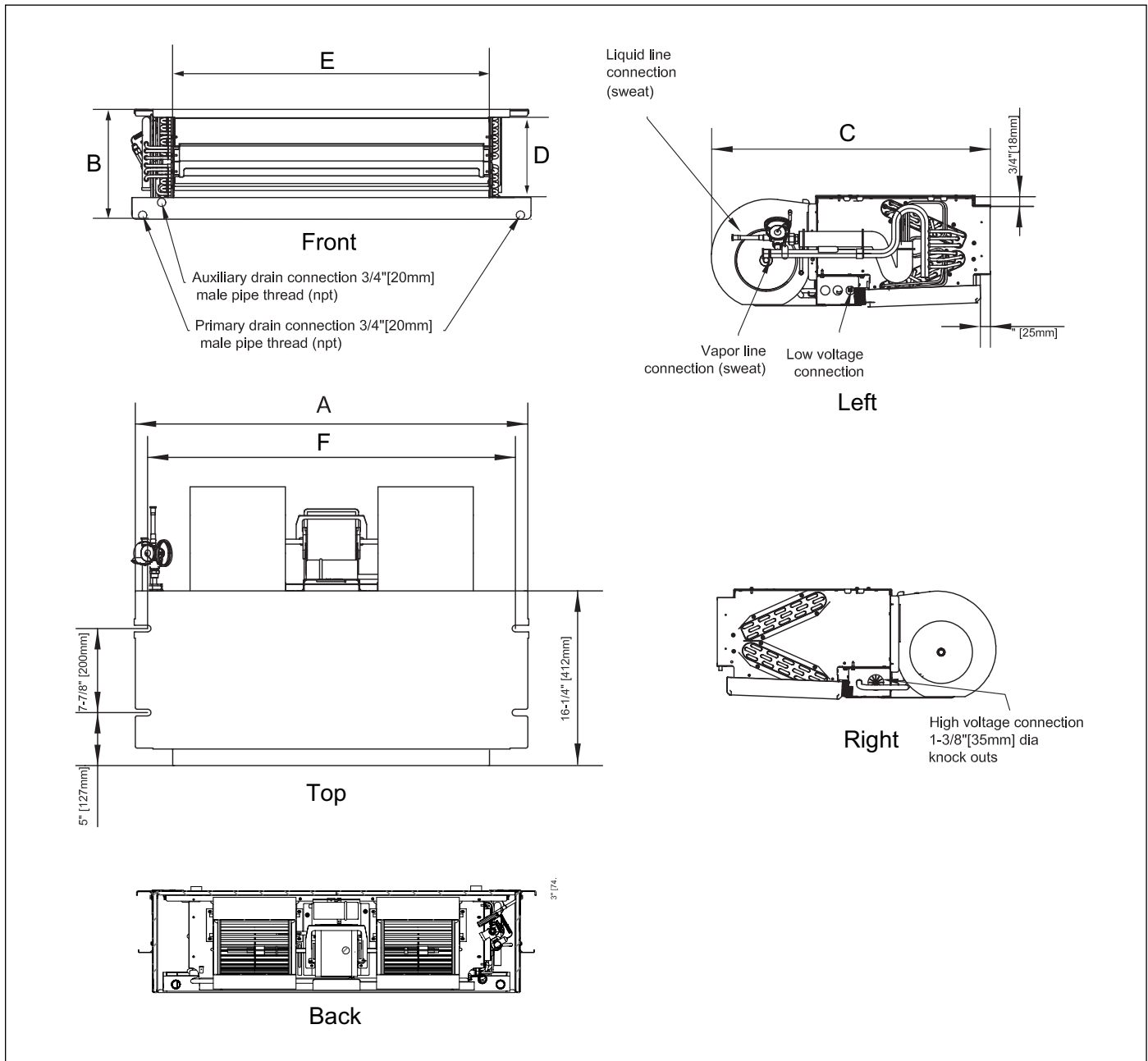

Figure 1 Uncased unit dimensions

Model Size	Dimensions Inch [mm]						
	Unit Length A	Unit Height B	Unit Width C	Supply Air Height D	Supply Air Length E	Mounting F	Liquid Line/ Vapor Line
18	37-1/4 [946]	37-1/4 [946]	37-1/4 [946]	6-1/2 [165]	30 [762]	34-11/16 [881]	3/8/ 3/4 [9.5/ 19]
24	37-1/4 [946]	37-1/4 [946]	37-1/4 [946]	6-1/2 [165]	30 [762]	34-11/16 [881]	3/8/ 3/4 [9.5/ 19]
30	49-1/4 [1251]	49-1/4 [1251]	49-1/4 [1251]	6-1/2 [165]	42 [1067]	46-11/16 [1186]	3/8/ 3/4 [9.5/ 19]
36	49-1/4 [1251]	49-1/4 [1251]	49-1/4 [1251]	6-1/2 [165]	42 [1067]	46-11/16 [1186]	3/8/ 3/4 [9.5/ 19]

Table 1

**3.2 Cased Unit Dimensions**

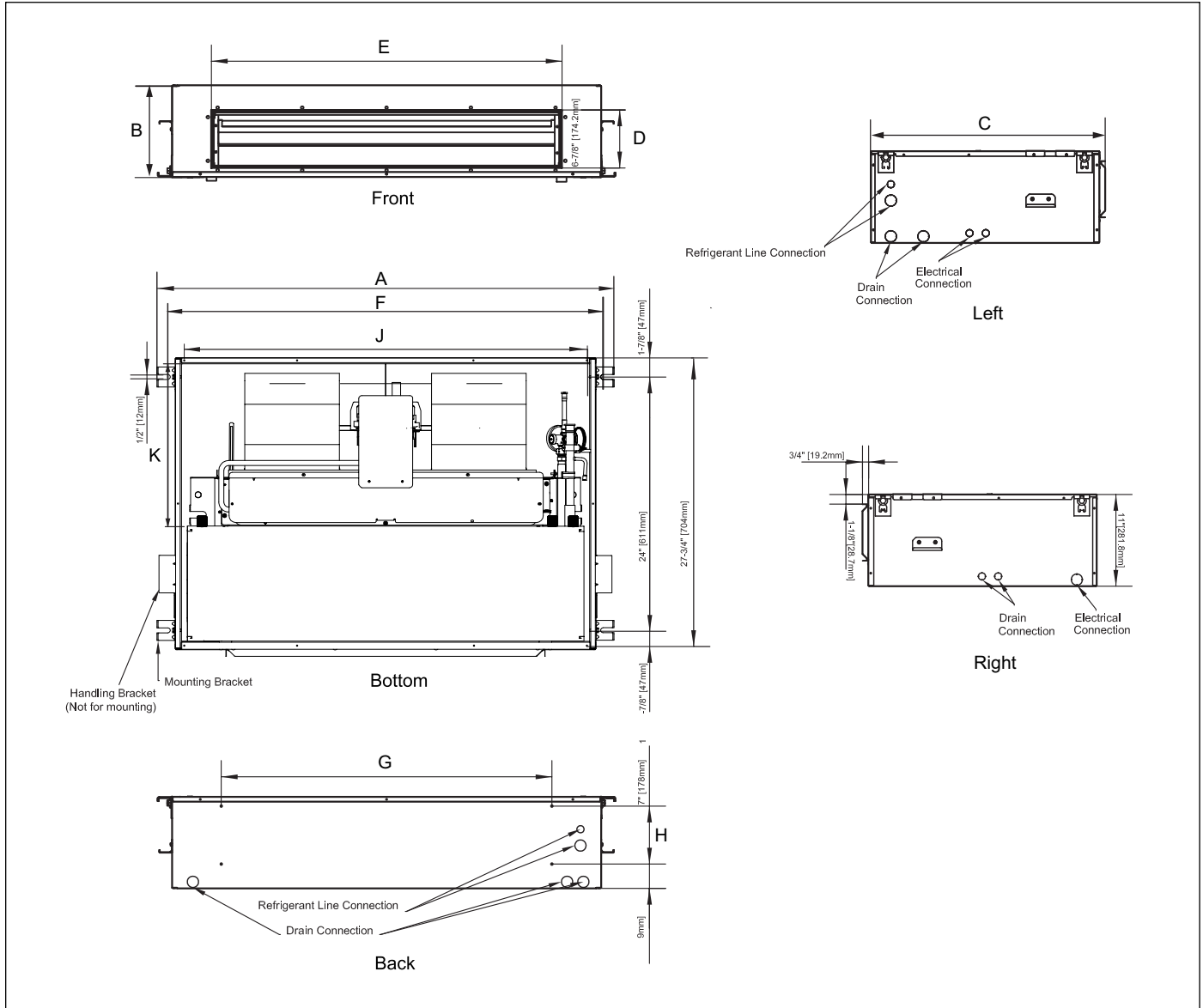

Figure 2 Cased unit dimensions

**i** Casings are sold separately as an accessory.

Model Size	Dimensions Inch [mm]										
	Unit Length A	Unit Height B	Unit Width C	Supply Air Height D	Supply Air Length E	Mounting F	Return Air Cutout Length G	Return Air Cutout Height H	Max Filter Length J	Max Filter Width K	Liquid Line/ Vapor Line
18	43-3/8 [1102]	11-1/8 [283]	28-3/8 [720]	6-7/8 [174]	30-3/8 [771]	41-5/16 [1050]	28 [711]	7 [178]	39 [990]	15-9/16 [395]	3/8/ 3/4 [9.5/ 19]
24	43-3/8 [1102]	11-1/8 [283]	28-3/8 [720]	6-7/8 [174]	30-3/8 [771]	41-5/16 [1050]	28 [711]	7 [178]	39 [990]	15-9/16 [395]	3/8/ 3/4 [9.5/ 19]
30	55-3/8 [1407]	11-1/8 [283]	28-3/8 [720]	6-7/8 [174]	42-3/16 [1071]	53-5/16 [1354]	40 [1016]	7 [178]	51 [1295]	15-9/16 [395]	3/8/ 3/4 [9.5/ 19]
36	55-3/8 [1407]	11-1/8 [283]	28-3/8 [720]	6-7/8 [174]	42-3/16 [1071]	53-5/16 [1354]	40 [1016]	7 [178]	51 [1295]	15-9/16 [395]	3/8/ 3/4 [9.5/ 19]

Table 2

## 4 Mounting

Mounting slots on the top of the unit are provided for attachment of the unit to supporting structure. The supporting structure must be designed to safely support the full weight of the unit. Field supplied washers and bolts capable of supporting the unit load should be used to secure the unit to the supporting structure at the mounting slots.

The unit must be mounted level to ensure proper drainage of condensate. If the supporting structure is not level at the mounting attachment, then spacers must be used to level the unit.

## 5 Electrical wiring

Field wiring must comply with the National Electric Code (C.E.C. in Canada) and any applicable local ordinances.



### WARNING: ELECTRICAL SHOCK

Disconnect all power to unit before installing or servicing. More than one disconnect switch may be required to deenergize the equipment. Hazardous voltage can cause severe personal injury or death.

### 5.1 Power Wiring

It is important that proper electrical power is available for connection to the unit being installed. See the unit nameplate, wiring diagram, and electrical data in the installation instructions for more detailed requirements.

- ▶ If required, install a branch circuit disconnect of adequate size, located within sight, and readily accessible from the unit.
- ▶ Supply circuit power wiring must be 221°F minimum copper conductors only. See Electrical Data in this section for ampacity, wire size and circuit protector requirements. Supply circuit protection devices may be either fuses or “HACR” type circuit breakers.
- ▶ High voltage wiring must be connected to the red and black wiring in the control section of the air handler.

### 5.2 Control Wiring



Low voltage control wiring should not be run in conduit with high voltage wiring. Keep distance between the two conduits per local codes.

- ▶ 18 AWG. color-coded low voltage wire should be used for lengths less than 100ft. For wire lengths longer than 100 ft., 16 AWG. wire should be used.
- ▶ For low voltage wire connection location, see Figures 1 and 2.
- ▶ See wiring diagram located on the bottom of air handler for proper wiring instruction.
- ▶ After installation, ensure separation of low voltage and high voltage wiring is maintained.

## 5.3 Grounding



### DANGER: ELECTRICAL SHOCK

The unit must be permanently grounded. Failure to do so can result in electrical shock causing personal injury or death.

- ▶ The ground may consist of electrical wire or metal conduit when installed in accordance with existing electrical codes.
- ▶ Grounding may also be accomplished by attaching ground wire(s) to ground lug provided in the unit wiring compartment.
- ▶ Use of multiple supply circuits require grounding of each circuit to lug provided in unit.
- ▶ Ground lug is located on the upper right side of the cabinet.

## 5.4 Electrical Data

Model	Voltage	Hertz	HP	Speeds	Blower Motor FLA	Maximum Circuit Protector
18	208/230	60	1/3	5	2.6	15(A)
24	208/230	60	1/3	5	2.6	15(A)
30	208/230	60	1/3	5	2.6	15(A)
36	208/230	60	1/3	5	2.6	15(A)

Table 3



## 6 Airflow Performance

Airflow performance data is based on cooling performance with a coil and no filter in place. Check the performance table for appropriate unit size selection. External static pressure should stay within the minimum and maximum limits shown in the table below in order to ensure proper operation of both cooling, heating, and electric heating operation.

### 6.1 Uncased Unit

Model	Motor Speed	SCFM, Uncased							
		External Static Pressure-Inches W.C. [kPa]							
		0[0]	0.1[.025]	0.15[.0375]	0.2[.050]	0.3[.075]	0.4[.100]	0.5[.125]	0.6[.150]
18	1	741	670	638	612	545	470	403	336
	2	925	860	819	788	727	655	588	500
	3	1069	1005	973	941	886	826	683	550
	4	1193	1140	1106	1071	970	850	700	560
	5	1288	1221	1177	1133	1024	895	745	575
24	1	741	670	638	612	545	470	403	336
	2	925	860	819	788	727	655	588	500
	3	1069	1005	973	941	886	826	683	550
	4	1193	1140	1106	1071	970	850	700	560
	5	1288	1221	1177	1133	1024	895	745	575
30	1	800	691	647	602	530	460	380	300
	2	1025	921	871	820	723	628	536	448
	3	1203	1106	1059	1011	916	822	729	636
	4	1339	1266	1224	1181	1085	978	859	729
	5	1468	1399	1361	1323	1253	1061	900	760
36	1	800	691	647	602	530	460	380	300
	2	1025	921	871	820	723	628	536	448
	3	1203	1106	1059	1011	916	822	729	636
	4	1339	1266	1224	1181	1085	978	859	729
	5	1468	1399	1361	1323	1253	1061	900	760

Table 4 Air performance - uncased unit

**□** Bold outlined areas represent airflow outside of the required 300-450 cfm/ton range.

**NOTES:**

1. Airflow data is without filter or electric heat. Electric Heater adds 0.05 in. static pressure.
2. Use wet coil data for determining cooling airflow.
3. Bottom louver panel adds 0.05 in. static pressure.

### 6.2 Cased Unit

Model	Motor Speed	SCFM, Cased, Back Return							
		External Static Pressure-Inches W.C. [kPa]							
		0[0]	0.1[.025]	0.15[.0375]	0.2[.050]	0.3[.075]	0.4[.100]	0.5[.125]	0.55[.1375]
18	1	753	655	609	564	481	407	340	309
	2	913	828	787	746	666	588	513	476
	3	1044	982	945	904	810	700	575	500
	4	1153	1058	1007	953	837	711	578	503
	5	1163	1068	1017	963	847	719	580	506
24	1	753	655	609	564	481	407	340	309
	2	913	828	787	746	666	588	513	476
	3	1044	982	945	904	810	700	575	500
	4	1153	1058	1007	953	837	711	578	503
	5	1163	1068	1017	963	847	719	580	506
30	1	801	700	651	602	508	418	331	288
	2	1015	916	869	822	731	645	562	523
	3	1177	1107	1069	1029	943	848	745	670
	4	1327	1279	1245	1203	1098	963	795	692
	5	1493	1404	1350	1289	1150	987	798	695
36	1	801	700	651	602	508	418	331	288
	2	1015	916	869	822	731	645	562	523
	3	1177	1107	1069	1029	943	848	745	670
	4	1327	1279	1245	1203	1098	963	795	692
	5	1493	1404	1350	1289	1150	987	798	695

Table 5 Air performance - cased unit, back return

Bold outlined areas represent airflow outside of the required 300-450 cfm/ton range.

**NOTES:**

1. Airflow data is without filter or electric heat. Electric Heater adds 0.05 in. static pressure.
2. Use wet coil data for determining cooling airflow.
3. Bottom louver panel adds 0.05 in. static pressure.

Model	Motor Speed	SCFM without Filter or Electric Heat, Cased, Bottom Return							
		External Static Pressure-Inches W.C. [kPa]							
		0[0]	0.1[.025]	0.15[.0375]	0.2[.050]	0.3[.075]	0.4[.100]	0.5[.125]	0.55[.1375]
18	1	756	658	611	566	480	400	325	290
	2	946	855	810	766	675	591	506	464
	3	1035	965	926	883	788	681	561	497
	4	1208	1110	1056	999	874	736	585	504
	5	1225	1132	1079	1023	898	758	602	518
24	1	756	658	611	566	480	400	325	290
	2	946	855	810	766	678	591	506	464
	3	1035	965	926	883	788	681	561	497
	4	1208	1110	1056	999	874	736	585	504
	5	1225	1132	1079	1023	898	758	602	518
30	1	796	712	670	626	537	445	351	302
	2	1012	901	850	801	709	627	555	522
	3	1156	1083	1044	1002	911	811	702	616
	4	1310	1197	1150	1101	980	850	708	626
	5	1469	1328	1256	1182	1031	875	714	632
36	1	796	712	670	626	537	445	351	302
	2	1012	901	850	801	709	627	555	522
	3	1156	1083	1044	1002	911	811	702	616
	4	1310	1197	1150	1101	980	850	708	626
	5	1469	1328	1256	1182	1031	875	714	632

Table 6 Air performance without filter/electric heat - cased unit, bottom return

**□** Bold outlined areas represent airflow outside of the required 300-450 cfm/ton range.

**NOTES:**

1. Airflow data is without filter or electric heat. Electric Heater adds 0.05 in. static pressure.
2. Use wet coil data for determining cooling airflow.
3. Bottom louver panel adds 0.05 in. static pressure.

**6.3 Required Airflow Range for Normal Operation**

Model	SCFM	
	Min	Max
18	450	675
24	600	900
30	750	1125
36	900	1350

Table 7 Airflow range for normal operation

---

## 7 Ductwork

Field ductwork must comply with the National Fire Protection Association NFPA 90A, NFPA 90B and any applicable local ordinance(s).

**WARNING: FIRE HAZARD AND CARBON MONOXIDE**

Do not, under any circumstances, connect return ductwork to any other heat producing device such as fireplace insert, stove, etc. Unauthorized use of such devices may result in fire, carbon monoxide poisoning, explosion, personal injury or property damage.

Sheet metal ductwork run in unconditioned spaces must be insulated and covered with a vapor barrier. Fibrous ductwork may be used if constructed and installed in accordance with SMACNA Construction Standard on Fibrous Glass Ducts. Ductwork must comply with National Fire Protection Association as tested by U/L Standard 181 for Class I Air Ducts. Check local codes for requirements on ductwork and insulation.

- ▶ Duct system must be designed within the range of external static pressure the unit is designed to operate against. It is important that the system airflow be adequate. Make sure supply and return ductwork, grills, special filters, accessories, etc. are accounted for in total resistance. See airflow performance tables in Section 5 of this manual.
- ▶ Design the duct system in accordance with "ACCA" Manual "D" Design for Residential Winter and Summer Air Conditioning and Equipment Selection. Latest editions are available from: "ACCA" Air Conditioning Contractors of America, 1513 16th Street, N.W., Washington, D.C. 20036. If duct system incorporates flexible air duct, be sure pressure drop information (straight length plus all turns) shown in "ACCA" Manual "D" is accounted for in system.



If an elbow is included in the plenum close to the unit, it must not be smaller than the dimensions of the supply duct flange on the unit.

- 
- ▶ Secure the supply and return ductwork to the unit flanges, using proper fasteners for the type of duct used and tape the duct-to-unit joint as required to prevent air leaks.

## 8 Refrigerant Connections

Keep the coil connections sealed until refrigerant connections are made. Refer to the Bosch IDS Condenser Section Installation, Operation, and Maintenance Manual for details on line sizing, tubing installation, and charging information.

Coil is factory charged with Nitrogen. Evacuate the system before charging with refrigerant.

Install refrigerant lines so that they do not block service access to the unit. Nitrogen should flow through the refrigerant lines while brazing.

Use a brazing shield to protect the cabinet and a wet rag to protect the rubber grommet and input pipe's piston seal ring from being damaged by torch flames. Use a wet rag or an approved heat paste to protect the TXV sensing bulb during the brazing process.

After the refrigerant line connections are made, seal the gap around the connections with pressure sensitive gasket.

After the brazing work is finished, make sure to check that there is no refrigerant leakage. After checking for vapor leaks, be sure to insulate the pipe connections, refer to Figure 3.

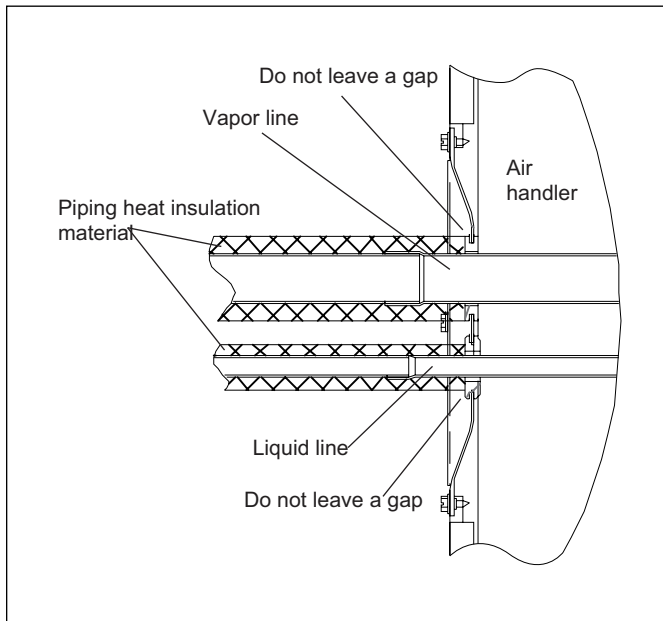

Figure 3 Insulation of pipe connections

### 8.1 Condensate Drain Connection

Consult local codes for specific requirements.

Refer to Figure 4 and the information below for required condensate drain trap installation.

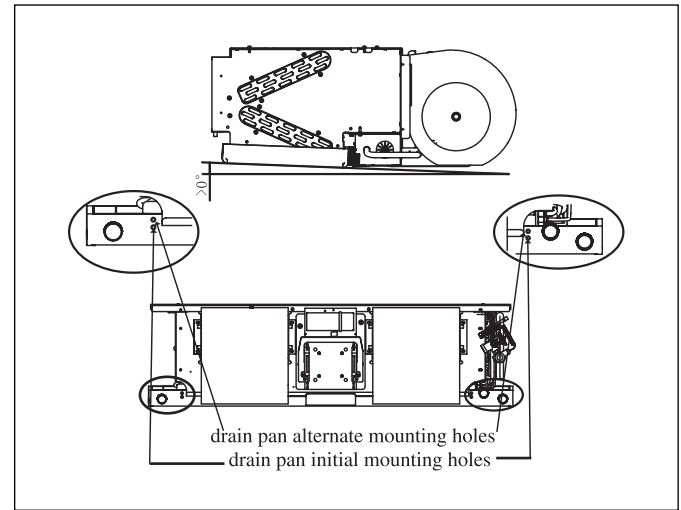

Figure 4

**i** When making drain fitting connections to the drain pan, use a thin layer of Teflon paste, silicone or Teflon tape and install by hand tightening.

**i** When making drain fitting connections to drain pan, do not overtighten. Over tightening fittings can split pipe connections on the drain pan.

Condensate pan has primary and secondary drain connections to meet FHA requirements. These connections have 3/4" (19 mm) male pipe threads.

All condensate drain line sizes should be a minimum of 7/8" (22 mm) OD. Drain lines from condensate pan to exterior of unit must be plastic pipe.

The condensate drain line should be tilted downward at a slope of 1 inch per 10 ft (25 mm per 3 m).

Additional mounting holes are available if more slope is desired by installer. See figure 4 for drain pan alternate mounting hole locations.

If coil is located in or above a living space where damage may result from condensate overflow, a separate 3/4" (19 mm) drain must be provided from secondary drain connection. Run this drain to a place in compliance with local installation codes where it will be noticed when unit is operational.

Condensate flow from secondary drain indicates a plugged primary drain. Install a 2" (51 mm) trap in condensate drain line as close to the unit as possible. Make sure that the top of trap is below connection to drain pan to prevent condensate from overflowing.

Prime all traps, test for leaks, and insulate in areas where sweating of the traps and drain lines could potentially cause water damage.

**i** Refer to local code requirements for usage of auxiliary drain pan and condensate overflow switch.

---

## 9 Air Filter (Not Factory-Installed)

Filters are not included with the unit and must be field supplied.

All return air must be filtered. The unit can be installed with or without a return-air duct. When installed as a ducted return, an insulated cover for the bottom casing opening must be field supplied. When installed without return-air duct (free return application), the space housing of the unit must be fully sealed except for the the return air connection to the conditioned space. Air filters should be located at the return air openings to the unit.

If adding high efficiency filters or electronic air filtration systems, it is very important that the air flow is not reduced. If air flow is reduced the overall performance and efficiency of the unit will be reduced. It is strongly recommended that a professional installation technician is contacted to ensure such filtration systems are installed correctly.



Do not double filter the return air duct system. Do not filter the supply air duct system. This will change the performance of the unit and reduce airflow.

---



### **WARNING: FIRE HAZARD**

Do not operate the system without filters. A portion of the dust suspended in the air may temporarily lodge in the duct runs and at the supply registers. Any circulated dust particles could be heated and charred by contact with the air handler elements. This residue could soil ceilings, walls, drapes, carpets and other articles in the house. Soot damage may occur with filters in place, when certain types of candles, oil lamps or standing pilots are burned.

## 10 Maintenance



For continuing high performance and to minimize possible equipment failure, annual maintenance must be performed on this equipment.

### 10.1 Cleaning Precautions

**WARNING: PERSONAL INJURY, PRODUCT DAMAGE**

Any unit repairs must be performed by qualified service personnel only.

**WARNING: ELECTRICAL SHOCK**

Always turn off your heat pump and disconnect its power supply before cleaning or maintenance.

**WARNING: FIRE HAZARD**

Do not use chemicals or chemically treated cloths to clean the unit.

Do not use benzene, paint thinner, polishing powder or other solvents to clean the unit.

Do not operate the system without a filter in place

**CAUTION: PERSONAL INJURY**

When removing filter, do not touch metal parts in the unit. The sharp metal edges can cut you.

### 10.2 Regular Maintenance

Your heat pump must be inspected annually by a qualified service technician. Your annual system inspection must include:

1. Inspect the air filter every thirty days or as often as needed. If blocked or obstructed, clean or replace at once.
2. Inspection and/or cleaning of the blower wheel housing and motor. The blower motor is permanently lubricated for normal operating conditions.
3. Inspection and cleaning of indoor and outdoor coils as required.
4. Inspection and/or cleaning of the indoor coil drain pan and drain lines, as well as auxiliary drain pan and lines.
5. Check all electrical wiring and connections. Correct as needed, referring to the wiring diagram.
6. Inspect outdoor unit to make sure that no debris or vegetation is within the required clearance distances.

## 11 Wiring Diagrams



**WARNING: ELECTRICAL SHOCK**

Disconnect all power before servicing or installing this unit. Multiple power sources may be present. Failure to do so may cause property damage, personal injury or death.



**DANGER: ELECTRICAL SHOCK**

This unit must be properly grounded and protected by a circuit breaker or fuse.



**WARNING: ELECTRICAL SHOCK**

These units must be wired and installed in accordance with all National and Local Safety Codes.

- ▶ To avoid electrical shock, please ensure:
  - The heat pump is properly grounded
  - The main power plug to the heat pump has been joined with the ground wiring (DO NOT ALTER THIS).
- ▶ Do not strain the power wiring.



For thermostat wiring please refer to the Owner's Manual of the thermostat.

### Electric wiring gauge for H/P systems

		Model(Btu/h)			
		18	24	30	36
Power	Phase	Single			
	Voltage/frequency	208/230VAC, 60Hz			
Input Current Fuse	Indoor unit (A)	15A	15A	15A	15A
	Line Quantity	3	3	3	3
Indoor Unit Power Line	Line Diameter (AWG)	14	14	14	14
	Line Quantity	3	3	3	3
Outdoor Unit Power Line	Line Diameter (AWG)	14	14	12	12
	Line Quantity	4	4	4	4
Outdoor -Indoor Signal Line	Line Diameter (AWG)	18	18	18	18
	Line Quantity	5	5	5	5
Thermostat Signal Line	Line Diameter (AWG)	18	18	18	18
	Line Quantity	5	5	5	5

Table 8

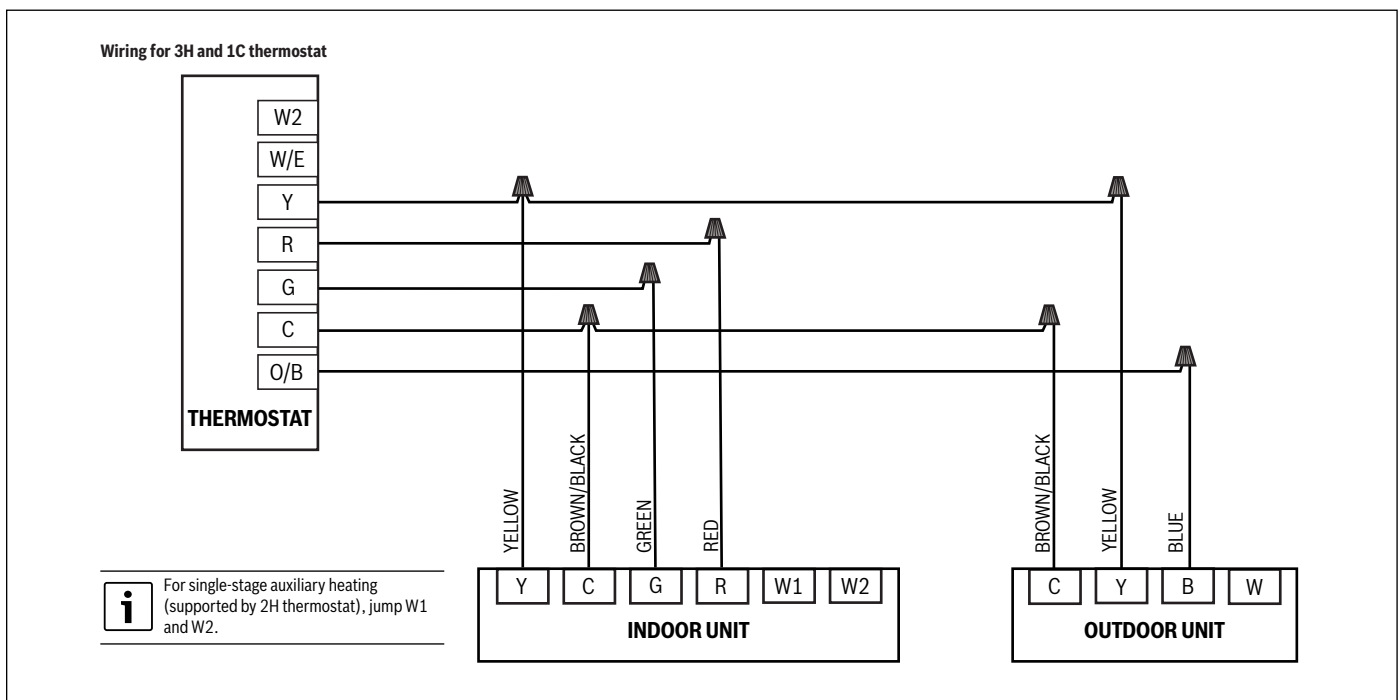

Figure 5 Thermostat wiring diagram for BOVA 15 with BCA series



**11.1 Unit Wiring**

For 24/36k Model

**SCHEMATIC DIAGRAM**  
SEE RATING PLATE FOR VOLTS&HERTZ  
**FIELD POWER WIRING**

**CAUTION:**  
NOT SUITABLE FOR USE ON SYSTEMS EXCEEDING 150V TO GROUND  
**ATTENTION:**  
NE CONVIENT PAS AUX INSTALLATIONS DE PLUS DE 150V ALA TERRE

TO THERMOSTAT	TO OUTDOOR UNIT
W <sub>1</sub> WHITE	W <sub>0</sub> BLACK/WHITE
Y <sub>1</sub> YELLOW	Y <sub>0</sub> PURPLE
R RED	
C BROWN	
G GREEN	

CAP AND SEAL THE UNUSED WIRE

**ELECTRIC HEAT WIRING**  
**CONNECTION (WHEN APPLIED)**

**COMPONENT ARRANGEMENT**

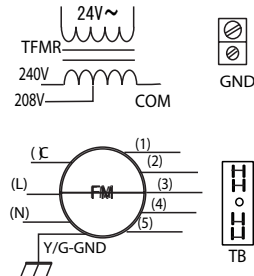
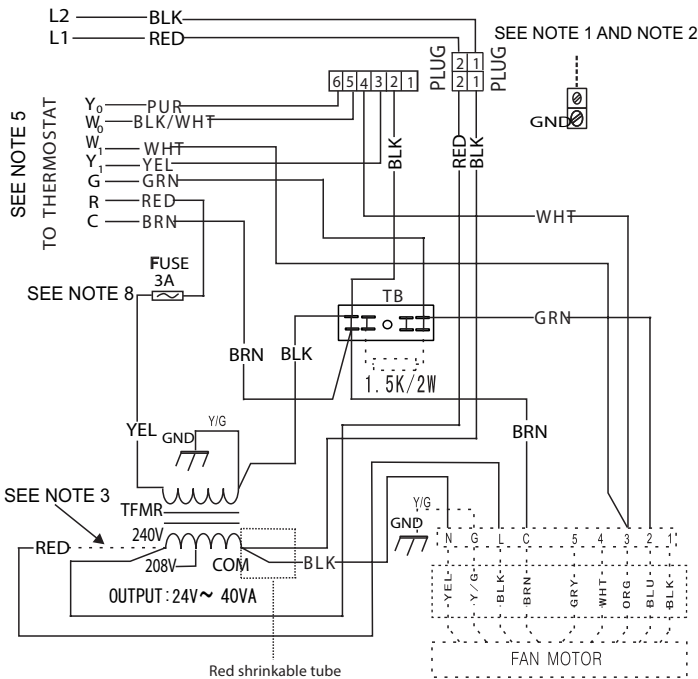

**SPEED TAP SELECTION**  
1 LOW  
2 MEDIUM LOW  
3 MEDIUM  
4 MEDIUM HIGH  
5 HIGH  
SEE NOTE 6

**TFMR TRANSFORMER**  
**TB TERMINAL BLOCK**  
**FM FAN MOTOR**  
**GND GROUND**

1602300008021

**NOTES:**

- 1: Use copper wire(75°C min) only between disconnect switch and unit, To be wired in accordance with N.E.C. and local codes. Fan coils equipped with electric heater connect power supply to terminal block. Cooling controls wiring not used with electric heaters.
- 2: If any of the original wire as supplied must be replaced, use the same or equivalent type wire.
- 3: Remove the red lead from 240V terminal and then connect the red lead to 208V terminal on the transformer for 208 volts.
- 4: To Change Speed Tap, Move green Wire To Desired Terminal 1 Through 5.
- 5: Connect R to R, G to G, etc. See outdoor or indoor instructions for details.
- 6: See Airflow Tables For Tap Usage.
- 7: N.E.C. Class 2, 24volts.
- 8: The fuse model is 32V/ 3A. Fuse Manufacturer: Littelfuse, fuse part number: 0257003.

Figure 6 Indoor Unit Wiring Diagram for 24/36k Models

For 18/30k Model

**SCHEMATIC DIAGRAM**  
SEE RATING PLATE FOR VOLTS&HERTZ  
**FIELD POWER WIRING**

**CAUTION:**  
NOT SUITABLE FOR USE ON SYSTEMS EXCEEDING 150V TO GROUND  
**ATTENTION:**  
NE CONVIENT PAS AUX INSTALLATIONS DE PLUS DE 150V ALA TERRE

- |                       |                            |
|-----------------------|----------------------------|
| TO THERMOSTAT         | TO OUTDOOR UNIT            |
| W <sub>1</sub> WHITE  | W <sub>0</sub> BLACK/WHITE |
| Y <sub>1</sub> YELLOW | Y <sub>0</sub> PURPLE      |
| R RED                 |                            |
| C BROWN               |                            |
| G GREEN               |                            |
- CAP AND SEAL THE UNUSED WIRE

**ELECTRIC HEAT WIRING CONNECTION (WHEN APPLIED)**

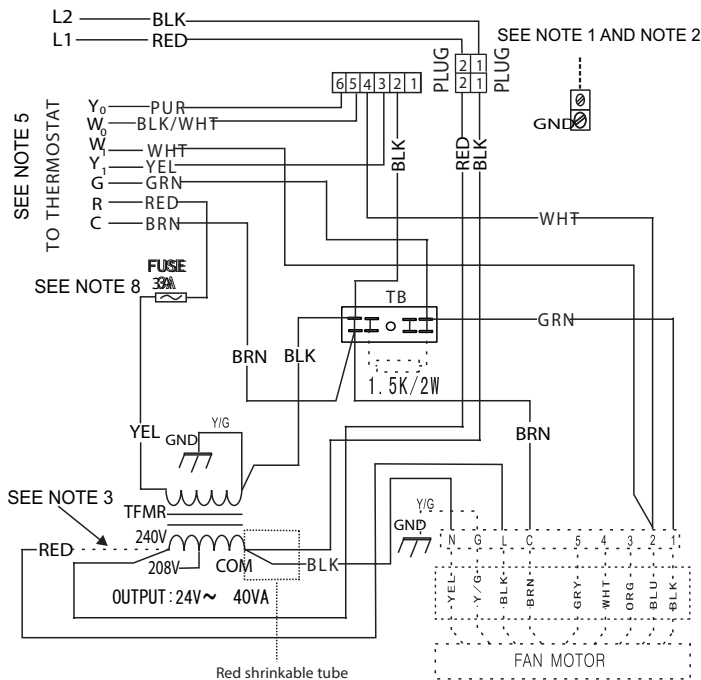

**COMPONENT ARRANGEMENT**

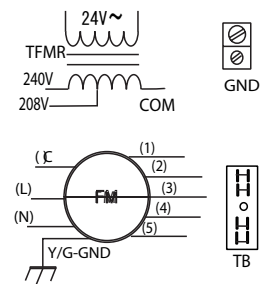

**SPEED TAP SELECTION**

- 1 LOW
- 2 MEDIUM LOW
- 3 MEDIUM
- 4 MEDIUM HIGH
- 5 HIGH

SEE NOTE 6

TFMR TRANSFORMER  
TB TERMINAL BLOCK  
FM FAN MOTOR  
GND GROUND

1602300008026

- NOTES:
- 1: Use copper wire (75°C min) only between disconnect switch and unit. To be wired in accordance with N.E.C. and local codes. Fan coils equipped with electric heater connect power supply to terminal block. Cooling controls wiring not used with electric heaters.
  - 2: If any of the original wire as supplied must be replaced, use the same or equivalent type wire.
  - 3: Remove the red lead from 240V terminal and then connect the red lead to 208V terminal on the transformer for 208 volts.
  - 4: To Change Speed Tap, Move green Wire To Desired Terminal 1 Through 5.
  - 5: Connect R to R, G to G, etc. See outdoor or indoor instructions for details.
  - 6: See Airflow Tables For Tap Usage.
  - 7: N.E.C. Class 2, 24volts.
  - 8: The fuse model is 32V/3A. Fuse Manufacturer: Littelfuse, fuse part number: 0257003.

Figure 7 Indoor Unit Wiring Diagram for 18/30k Models

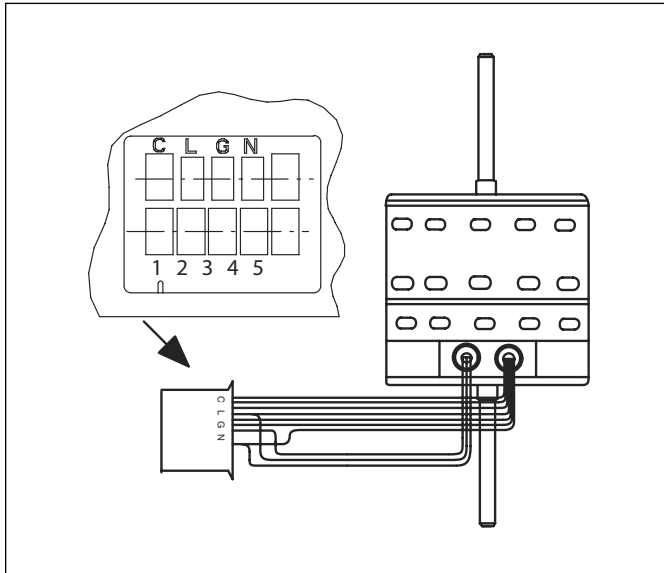

Figure 8 Ceiling mounted AHU ECM motor speed taps

Tap	Delay - Off Time(s)	18	24	30	36
Tap 1	90	Default	—	—	—
Tap 2	90	—	Default	—	—
Tap 3	90	—	—	Default	—
Tap 4	90	—	—	—	Default
Tap 5	90	—	—	—	—

Table 9 ECM motor speed taps



**To Change the Fan Speed Tap:**

At the motor connection plug, connect the green wire into the desired Fan Speed Tap where indicated on the Blower Motor Plug.

The blower motor is equipped with a Time Delay Board (TDB). There is a 90 second Fan-off delay when G is de-energized on the thermostat terminal. This setting cannot be changed.

**Online Help Resources**

Alternatively, please visit our Service & Support webpage to find FAQs, videos, service bulletins, and more; [www.boschheatingcooling.com/service](http://www.boschheatingcooling.com/service) or use your cellphone to scan the code below.

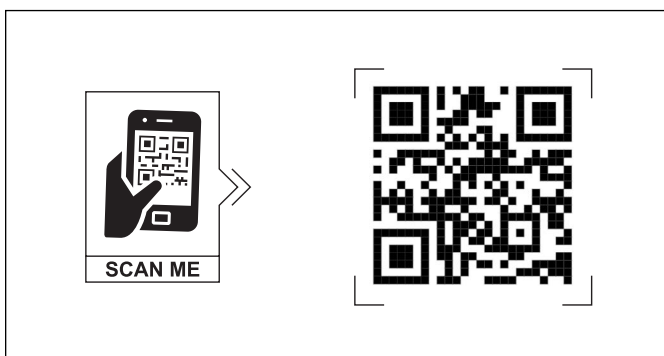

Figure 9

**United States and Canada  
Bosch Thermotechnology Corp.  
65 Grove St.  
Watertown, MA 02472**

**Tel: 866-642-3198  
Fax: 954-776-5529  
[www.bosch-thermotechnology.us](http://www.bosch-thermotechnology.us)**

**BTC 761703106 A / 03.2023**

**Bosch Thermotechnology Corp. reserves the right  
to make changes without notice due to continuing  
engineering and technological advances.**