

AIR CONDITIONER

Duct type

SERVICE MANUAL

For Extra Cold Climate Area

INDOOR



AMUG30LMAS
AMUG36LMAS
AMUG48LMAS

OUTDOOR



AOUH30LUAH1



AOUH36LMAH1
AOUH48LMAH1

Notices:

- Product specifications and design are subject to change without notice for future improvement.
- For further details, please check with our authorized dealer.

CONTENTS

1. GENERAL INFORMATION

2. TECHNICAL DATA AND PARTS LIST

3. TROUBLESHOOTING

4. CONTROL AND FUNCTIONS

5. FIELD WORKING

1. GENERAL INFORMATION

CONTENTS

1. GENERAL INFORMATION

1. Specifications	01-1
1-1. Indoor unit	01-1
1-2. Outdoor unit.....	01-3
2. Dimensions	01-5
2-1. Indoor unit	01-5
2-2. Outdoor unit.....	01-8

1. Specifications

1-1. Indoor unit

Type				Duct			
				Inverter heat pump			
Model name				AMUG30LMAS	AMUG36LMAS	AMUG48LMAS	
Power supply				208/230 V ~ 60 Hz			
Power supply intake				Outdoor unit			
Available voltage range				187—253 V			
Capacity	Cooling	Rated	kW	8.38	9.67	13.33	
			Btu/h	28,600	33,000	45,500	
		Min.—Max.	kW	2.81—10.26	3.81—11.43	3.81—14.65	
			Btu/h	9,600—35,000	13,000—39,000	13,000—50,000	
	Heating	47 °FDB (Outdoor temp.)	Rated	kW	9.38	11.13	14.95
				Btu/h	32,000	38,000	51,000
		Min.—Max.	kW	2.70—11.43	4.40—15.24	4.40—16.12	
			Btu/h	9,200—39,000	15,000—52,000	15,000—55,000	
		17 °FDB (Outdoor temp.)	Rated	kW	6.33	7.50	10.08
				Btu/h	21,600	25,600	34,400
Max.	kW	10.18	13.15	14.95			
	Btu/h	34,730	44,880	51,000			
Input power	Cooling	Rated	kW	2.39	2.87	5.00	
				0.44—3.40	0.85—3.66	0.85—6.00	
		Min.—Max.	Rated	2.58	2.85	4.13	
			Min.—Max.	0.60—4.17	0.90—4.96	0.90—5.41	
	Heating	47 °FDB (Outdoor temp.)	Rated	kW	2.09	2.45	3.50
					5.00	5.89	6.52
		17 °FDB (Outdoor temp.)	Rated	kW	2.09	2.45	3.50
					5.00	5.89	6.52
	Fan	HIGH	MED	W	136.3	204.3	412.4
					96.3	63.4	118.2
					57.7	42.1	73.1
					22.7	31.0	38.5
Current	Cooling	Rated	A	10.7	12.8	22.2	
				11.4	12.7	18.4	
EER	Cooling	kW/kW	Btu/hW	3.51	3.37	2.66	
				12.0	11.5	9.10	
COP	Heating	kW/kW	Btu/hW	3.64	3.90	3.62	
				12.4	13.3	12.3	
SEER	Cooling	Btu/hW		19.1	17.3	16.3	
HSPF	Heating	Btu/hW		10.5	11.0	10.2	
Power factor	Cooling	%		97.1	97.5	97.9	
	Heating	%		98.4	97.6	97.6	
Moisture removal			pints/h (L/h)	6.8 (3.2)	6.6 (3.1)	9.3 (4.4)	
Maximum operating current *1	Cooling	A		19.8	23.9	28.9	
	Heating	A		26.8	32.9	35.9	
Fan	Airflow rate	Cooling	CFM (m ³ /h)	HIGH	870 (1,478)	1,200 (2,039)	1,640 (2,786)
				MED	730 (1,240)	740 (1,257)	1,020 (1,733)
				LOW	590 (1,002)		
				QUIET	310 (527)	490 (833)	590 (1,002)
		Heating	CFM (m ³ /h)	HIGH	870 (1,478)	1,200 (2,039)	1,640 (2,786)
				MED	730 (1,240)	740 (1,257)	1,020 (1,733)
				LOW	590 (1,002)		
				QUIET	310 (527)	490 (833)	590 (1,002)
		Type × Q'ty			Sirocco fan × 1		
		Static pressure range			inWG (Pa)	0.08 to 1 (20 to 250)	
Sound pressure level *2	Cooling	HIGH	dB (A)	42	41	48	
				MED	37	30	36
				LOW	33	27	31
				QUIET	28	24	25
	Heating	HIGH	dB (A)	39	40	47	
				MED	36	35	37
				LOW	32	28	32
				QUIET	25	26	29
Heat exchanger type	Dimensions (H × W × D)		in (mm)	16 × 17-1/8 × 1-1/2 (406 × 435 × 38)	32 × 17-1/8 × 1-1/2 (813 × 435 × 38)		
	Fin pitch		FPI	16	15		
	Rows × Stages			2 × 48	2 × 64		
	Pipe type			Aluminum			
	Fin type			Aluminum			
Enclosure	Material			Steel			
	Color			—			
Dimensions (H × W × D)	Net	in (mm)		42-1/2 × 21 × 21-11/16 (1,080 × 533 × 551)	57 × 21 × 21-11/16 (1,448 × 533 × 551)		
	Gross	in (mm)		42-3/4 × 24 × 25-5/16 (1,086 × 610 × 643)	57-1/8 × 23 × 26-1/2 (1,451 × 584 × 673)		
Weight	Net	lb (kg)		104 (47.0)	132 (60.0)		
	Gross	lb (kg)		116 (52.5)	146 (66.0)		
Connection pipe	Size	Liquid	in (mm)	Ø 3/8 (Ø 9.52)			
	Method	Gas		Ø 5/8 (Ø 15.88)			
Drain port	Method		Flare	Flare	Flare		
	Size	in (mm)		Ø 3/4 (19) [O.D.]	Ø 3/4 (19) [O.D.]	Ø 3/4 (19) [O.D.]	
Operation range	Cooling	°F (°C)		64 to 90 (18 to 32)			
		%RH		80 or less	—		
Operation range	Heating	°F (°C)		60 to 86 (16 to 30)			

Type	Duct		
	Inverter heat pump		
Model name	AMUG30LMAS	AMUG36LMAS	AMUG48LMAS
<p>NOTES:</p> <ul style="list-style-type: none"> • Specifications are based on the following conditions: <ul style="list-style-type: none"> – Cooling: Indoor temperature of 80 °FDB/67 °FWB (26.67 °CDB/19.44 °CWB), and outdoor temperature of 95 °FDB/75 °FWB (35 °CDB/23.9 °CWB). – Heating: Indoor temperature of 70 °FDB/59 °FWB (21.11 °CDB/15 °CWB), and outdoor temperature of 47 °FDB/43 °FWB (8.33 °CDB/6.11 °CWB). – Pipe length: 24 ft 7 in (7.5 m), Height difference: 0 ft (0 m). (Between outdoor unit and indoor unit.) – Standard static pressure: 0.18 in.WG (45 Pa): 24 model, 0.23 in.WG (58 Pa): 30, and 36 model, 0.28 in.WG (70 Pa): 48 model • Protective function might work when using it outside the operation range. • *1: Maximum current: <ul style="list-style-type: none"> – The maximum value when operated within the operation range. – The total current of indoor unit and outdoor unit. • *2: Sound pressure level: <ul style="list-style-type: none"> – Measured values in manufacturer's anechoic chamber. – Because of the surrounding sound environment, the sound levels measured in actual installation conditions might be higher than the specified values here. 			

1-2. Outdoor unit

Type			Inverter heat pump
Model name			AOUH30LUAH1
Power supply			208/230 V ~ 60 Hz
Power supply intake			Outdoor unit
Available voltage range			187—253 V
Starting current			11.4
Fan	Airflow rate	Cooling	CFM (m ³ /h)
		Heating	
	Type × Qty	Propeller × 1	
Motor output		W	111
Sound pressure level *	Cooling	dB (A)	52
	Heating		53
Heat exchanger type	Dimensions (H × W × D)	in (mm)	38-1/16 × 36-5/16 × 2-3/16 (966 × 922 × 55)
	Fin pitch	FPI	18
	Rows × Stages		3 × 46
	Pipe type		Copper
	Fin	Type (Material) Surface treatment	
Compressor	Type × Qty		DC twin rotary × 1
	Motor output	W	2,440
Refrigerant	Type		R410A
	Charge	lb oz	7 lb 8 oz
		g	3,400
Refrigerant oil	Type		POE (RB68)
	Amount	in ³ (cm ³)	70.2 (1,150)
	Enclosure	Material	
Color			Beige Approximate color of Munsell 10YR 7.5/1.0
Dimensions (H × W × D)	Net	in (mm)	39-5/16 × 38-3/16 × 14-9/16 (998 × 970 × 370)
	Gross	in (mm)	45-3/4 × 41-7/8 × 18-13/16 (1,162 × 1,064 × 478)
Weight	Net	lb (kg)	187 (85)
	Gross		209 (95)
Connection pipe	Size	Liquid	Ø 3/8 (Ø 9.52)
		Gas	Ø 5/8 (Ø 15.88)
	Method		Flare
	Pre-charge length	ft (m)	98 (30)
	Max. length		246 (75)
Max. height difference	98 (30)		
Operation range	Cooling	°F (°C)	-5 to 115 (-21 to 46)
	Heating		-15 to 75 (-26 to 24)
Drain hose	Material		LDPE
	Size	in (mm)	Ø1/2 (13.0) [I.D.], Ø5/8 to Ø11/16 (16.0 to 16.7) [O.D.]

NOTES:

- Specifications are based on the following conditions:
 - Cooling: Indoor temperature of 80 °FDB (26.67 °CDB) / 67 °FWB (19.44 °CWB), and outdoor temperature of 95 °FDB (35 °CDB) / 75 °FWB (23.9 °CWB).
 - Heating: Indoor temperature of 70 °FDB (21.11 °CDB) / 59 °FWB (15 °CWB), and outdoor temperature of 47 °FDB (8.33 °CDB) / 43 °FWB (6.11 °CWB).
 - Pipe length: 24 ft 6 in (7.5 m), Height difference: 0 ft (0 m). (Between outdoor unit and indoor unit.)
- Protective function might work when using it outside the operation range.
- *: Sound pressure level
 - Measured values in manufacturer's anechoic chamber.
 - Because of the surrounding sound environment, the sound levels measured in actual installation conditions might be higher than the specified values here.

Type			Inverter heat pump	
Model name			AOUH36LMAH1	AOUH48LMAH1
Power supply			208/230 V ~ 60 Hz	
Power supply intake			Outdoor unit	
Available voltage range			187—253 V	
Starting current			12.8	
Fan	Airflow rate	Cooling	3,767 (6,400)	22.2
		Heating		
	Type × Q'ty	3,649 (6,200)		
Motor output			Propeller × 1	
			111	
Sound pressure level *	Cooling	dB (A)	52	54
	Heating		53	54
Heat exchanger type	Dimensions (H × W × D)	in (mm)	51-1/4 × 36-13/16 × 1-9/16 (1,302 × 935 × 39.9)	
	Fin pitch	FPI	18	
	Rows × Stages	3 × 62		
	Pipe type	Copper		
	Fin	Type (Material)	Aluminum	
	Surface treatment	Blue Fin		
Compressor	Type × Q'ty	DC twin rotary × 1		
	Motor output	W	3,750	
Refrigerant	Type	R410A		
	Charge	lb oz	10 lb 9 oz	
		g	4,800	
Refrigerant oil	Type	POE (RB68)		
	Amount	in ³ (cm ³)	94.6 (1,550)	
Enclosure	Material	Steel		
	Color	Beige Approximate color of Munsell 10YR 7.5/1.0		
Dimensions (H × W × D)	Net	in (mm)	52-1/2 × 38-3/16 × 14-9/16 (1,334 × 970 × 370)	
	Gross	in (mm)	59-5/16 × 41-7/8 × 18-13/16 (1,506 × 1,064 × 478)	
Weight	Net	lb (kg)	236 (107)	
	Gross		260 (118)	
Connection pipe	Size	Liquid	Ø 3/8 (Ø 9.52)	
		Gas	Ø 5/8 (Ø 15.88)	
	Method	Flare		
	Pre-charge length	ft (m)	98 (30)	
	Max. length		246 (75)	
Max. height difference	98 (30)			
Operation range	Cooling	°F (°C)	-5 to 115 (-21 to 46)	
	Heating		-15 to 75 (-26 to 24)	
Drain hose	Material	LDPE		
	Size	in (mm)	Ø1/2 (13.0) [I.D.], Ø5/8 to Ø11/16 (16.0 to 16.7) [O.D.]	

NOTES:

- Specifications are based on the following conditions:
 - Cooling: Indoor temperature of 80 °FDB (26.67 °CDB) / 67 °FWB (19.44 °CWB), and outdoor temperature of 95 °FDB (35 °CDB) / 75 °FWB (23.9 °CWB).
 - Heating: Indoor temperature of 70 °FDB (21.11 °CDB) / 59 °FWB (15 °CWB), and outdoor temperature of 47 °FDB (8.33 °CDB) / 43 °FWB (6.11 °CWB).
 - Pipe length: 24 ft 6 in (7.5 m), Height difference: 0 ft (0 m). (Between outdoor unit and indoor unit.)
- Protective function might work when using it outside the operation range.
- *: Sound pressure level
 - Measured values in manufacturer's anechoic chamber.
 - Because of the surrounding sound environment, the sound levels measured in actual installation conditions might be higher than the specified values here.

2. Dimensions

2-1. Indoor unit

■ Models: AMUG30LMAS, AMUG36LMAS, and AMUG48LMAS

Unit: in (mm)

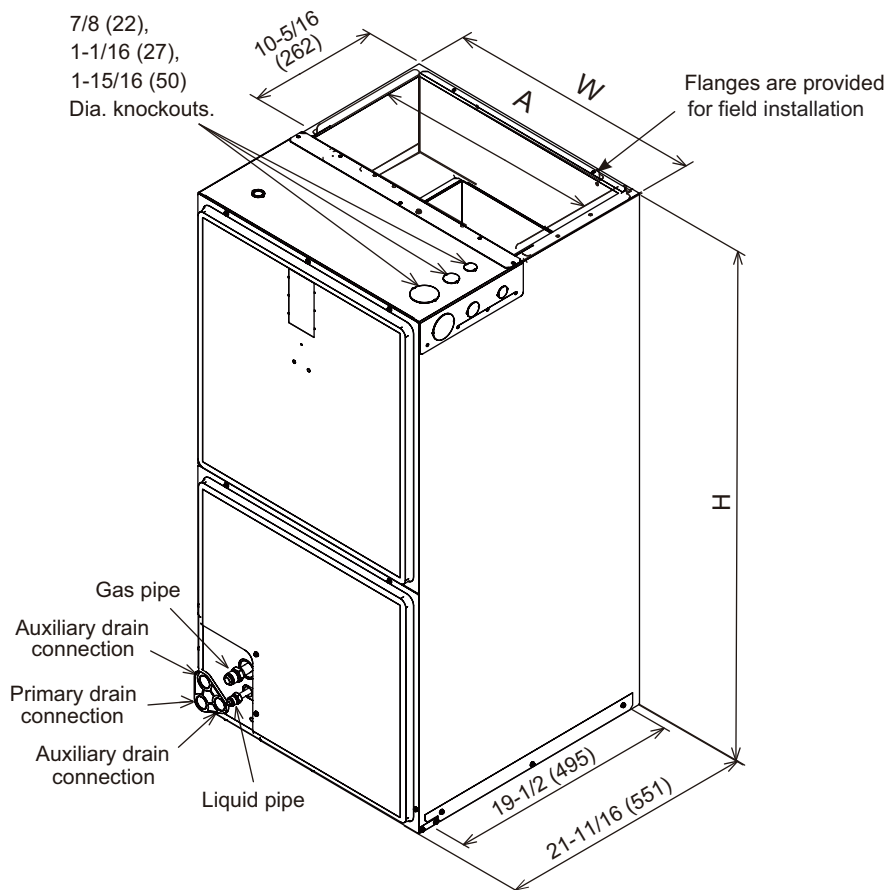

Model	Dimension		
	A (Supply duct)	W (Unit width)	H (Unit height)
AMUG30LMAS	19-1/2 (495)	21 (533)	42-1/2 (1,080)
AMUG36LMAS AMUG48LMAS	19-1/2 (495)	21 (533)	57 (1,448)

Model	Return air opening	
	Width	Depth/Length
AMUG30LMAS AMUG36LMAS AMUG48LMAS	19-3/8 (492)	19-3/4 (502)

■ Installation space requirement

Provide sufficient installation space for product safety.

(Top side)

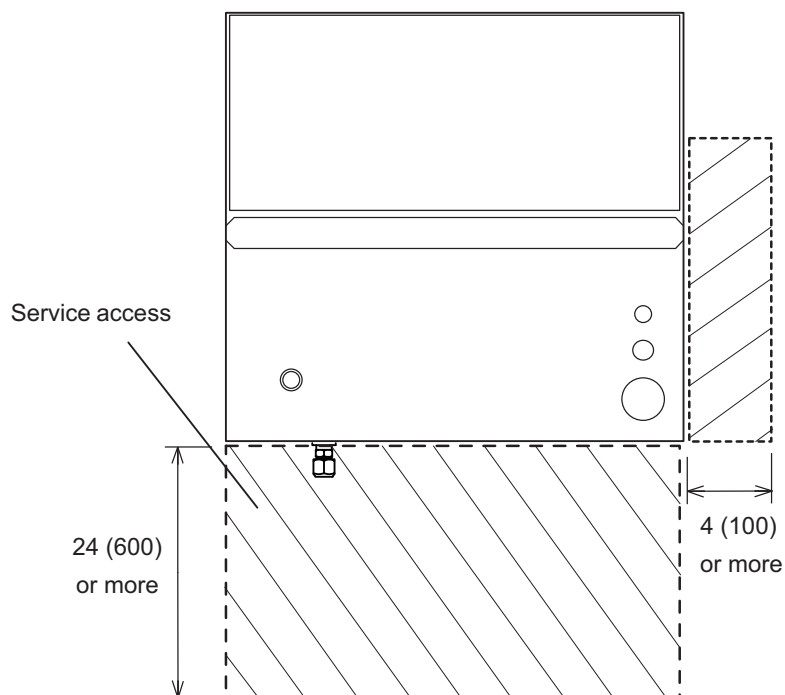

For installation method, the following 4 patterns

- **Pattern A: Vertical installation, air intake port at the bottom**

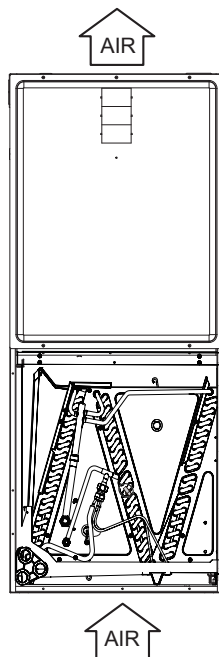

- **Pattern B: Horizontal installation, air intake port at the right**

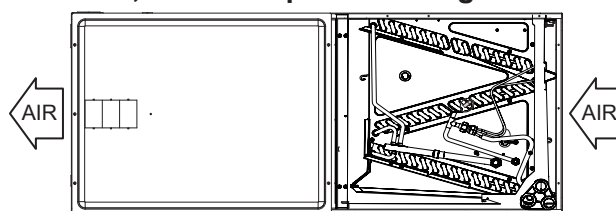

- **Pattern C: Vertical installation, air intake port at the top**
Reversing the heat exchanger and reattaching the thermistor are required

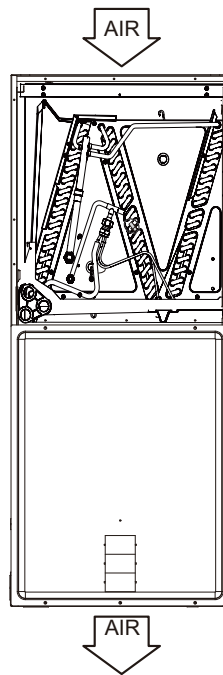

- **Pattern D: Horizontal installation, air intake port at the left**
Reversing the heat exchanger and reattaching the thermistor are required

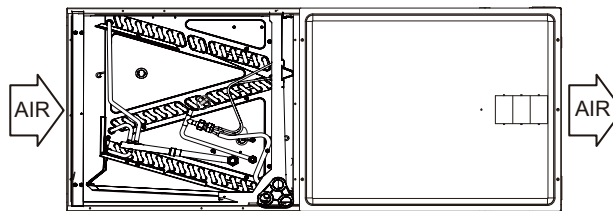

2-2. Outdoor unit

Model: AOUH30LUAH1

Unit: in (mm)

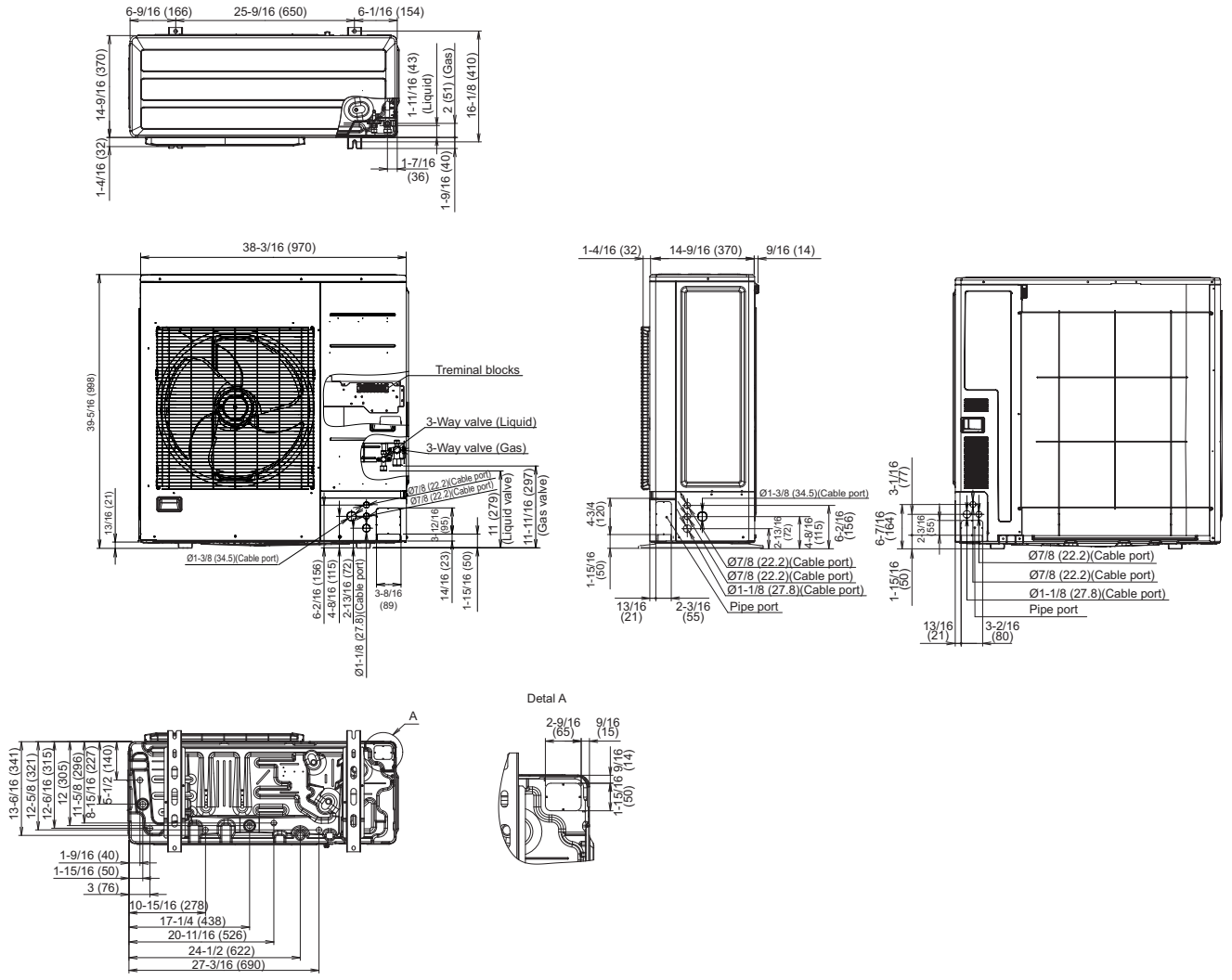

Model: AOUH36LMAH1

Unit: in (mm)

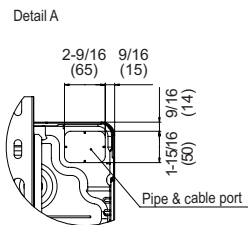
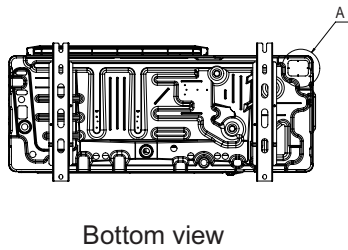
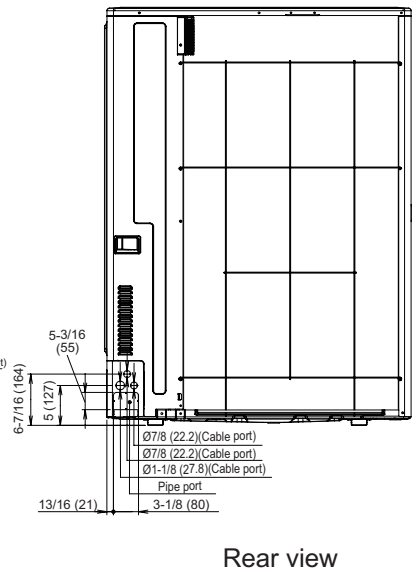
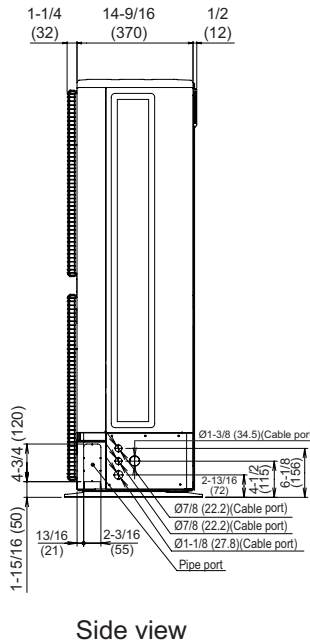
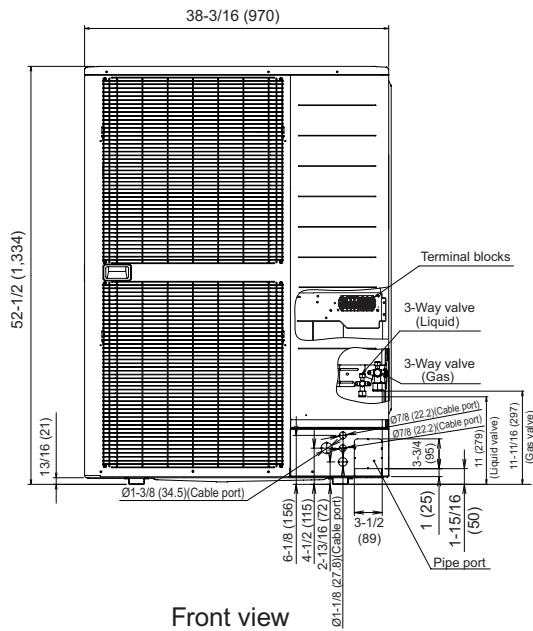
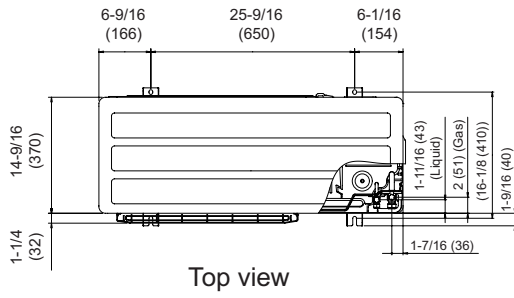

Model: AOUH48LMAH1

Unit: in (mm)

GENERAL INFORMATION

GENERAL INFORMATION

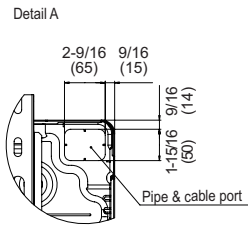
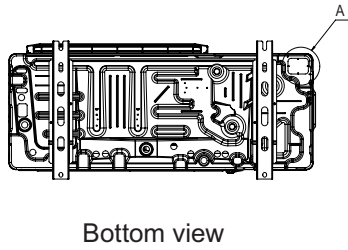
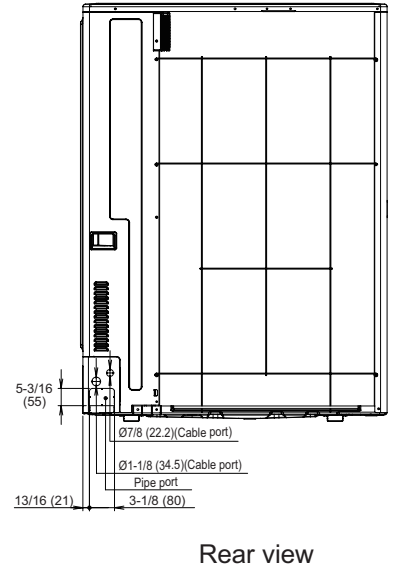
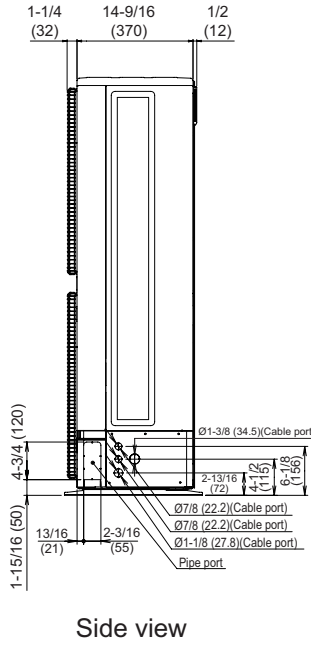
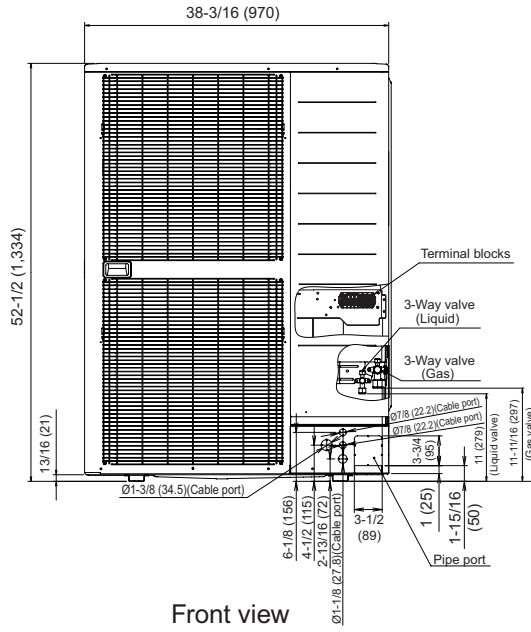
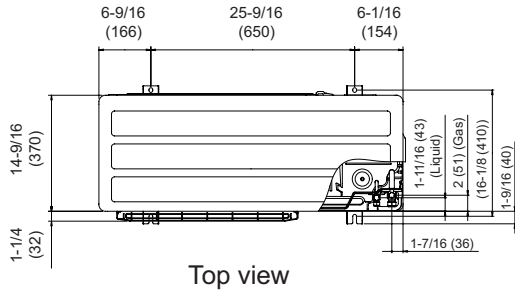

2. TECHNICAL DATA AND PARTS LIST

CONTENTS

2. TECHNICAL DATA AND PARTS LIST

1. Precautions	02-1
2. Indoor unit parts list	02-2
2-1. Models: AMUG30LMAS, AMUG36LMAS, and AMUG48LMAS.....	02-2
3. Outdoor unit parts list	02-8
3-1. Model: AOUH30LUAH1.....	02-8
3-2. Models: AOUH36LMAH1 and AOUH48LMAH1.....	02-12
4. Accessories	02-16
4-1. Indoor unit.....	02-16
4-2. Outdoor unit.....	02-16
5. Optional parts	02-17
5-1. Indoor unit.....	02-17
6. Refrigerant system diagrams	02-20
6-1. Models: AOUH30LUAH1, AOUH36LMAH1, and AOUH48LMAH1.....	02-20
7. Wiring diagrams	02-21
7-1. Indoor unit.....	02-21
7-2. Outdoor unit.....	02-22
8. PC board diagrams	02-23
8-1. Models: AMUG30LMAS, AMUG36LMAS, and AMUG48LMAS.....	02-23
8-2. Model: AOUH30LUAH1.....	02-24
8-3. Models: AOUH36LMAH1 and AOUH48LMAH1.....	02-25

1. Precautions

When you start servicing, pay attention to the following points. For detailed precautions, refer to the installation manual of the products.

⚠ CAUTION

- Service personnel
 - Any person who is involved with working on or breaking into a refrigerant circuit should hold a current valid certificate from an industry-accredited assessment authority, which authorizes their competence to handle refrigerants safely in accordance with an industry recognized assessment specification.
 - Servicing shall only be performed as recommended by the equipment manufacturer. Maintenance and repair requiring the assistance of other skilled personnel shall be carried out under the supervision of the person competent in the use of flammable refrigerants.
 - Servicing shall be performed only as recommended by the manufacturer.
-
- Service parts information and design are subject to change without notice for product improvement.
 - For the latest information of the service parts, refer to our Service Portal.
<https://fujitsu-general.force.com/portal/>
 - Precise figure of the service parts listed in this manual may differ from the actual service parts.

2. Indoor unit parts list

2-1. Models: AMUG30LMAS, AMUG36LMAS, and AMUG48LMAS

■ Exterior parts and chassis

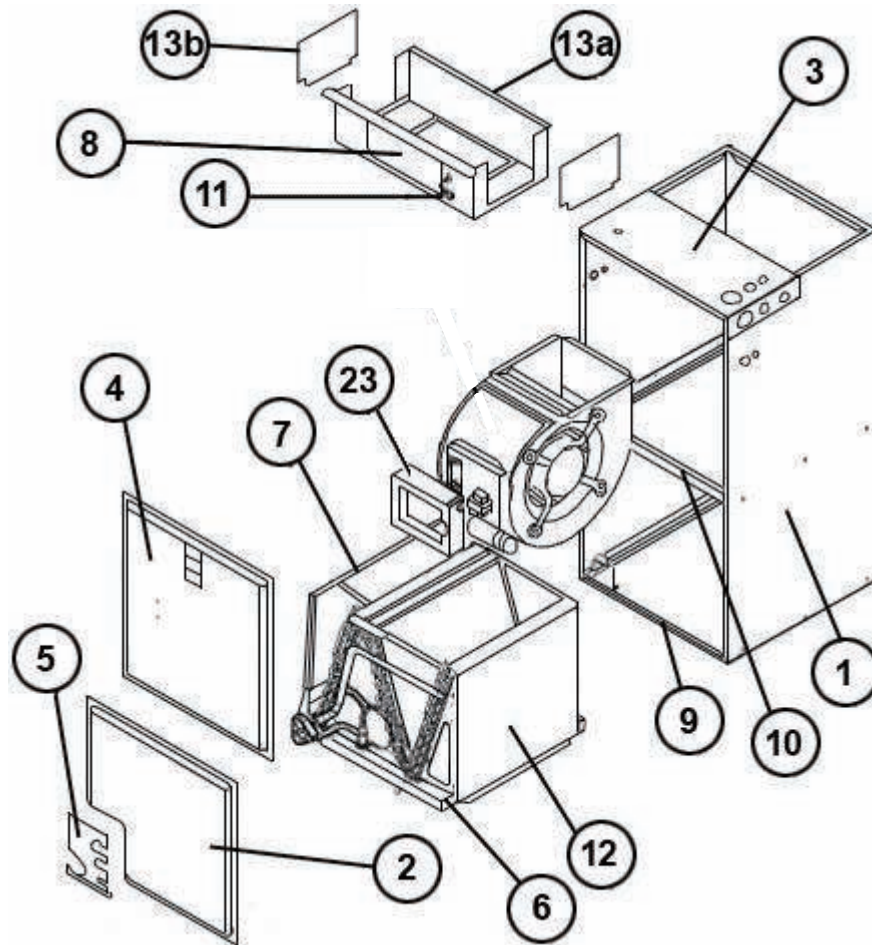

Item no.	Part name	Part no.		
		AMUG30LMAS	AMUG36LMAS	AMUG48LMAS
Panel, Sheet metal, Miscellaneous				
1	Insulation - Cabinet	68-101121-02	68-101121-15	68-101121-15
	Insulation Retainer Rod (2)	45-102868-03	45-102868-03	45-102868-03
2	Coil Door	AE-100685-23	N/A	N/A
	Insulation - Coil Door	68-101577-07	68-101577-10	68-101577-10
3	Top Cover Plate	AE-100686-02	AE-100686-02	AE-100686-02
	Insulation - Top Cover Plate	68-101122-02	68-101122-02	68-101122-02
4	Blower Door	AE-100684-22	AE-100684-22	AE-100684-22
	Insulation - Blower Door	68-101576-02	68-101576-02	68-101576-02
5	Access Panel	AE-101133-21	AE-101133-21	AE-101133-21
	Insulation - Access Panel	68-101644-01	68-101644-01	68-101644-01
6	Drain Pan - Vertical	See RCH Coil Parts List		
7	Drain Pan - Horizontal	See RCH Coil Parts List		
8	Plate - Block Off	AE-100455-01	AE-100455-01	AE-100455-01
9	Cabinet Brace	AE-101134-03	AE-101134-03	AE-101134-03
10	Middle Brace	AE-101054-02	AE-101054-02	AE-101054-02
13a	Heat Barrier	AE-100683-05	AE-100683-06	AE-100683-06
13b	Heat Barrier Side (2)	AE-104241-01	AE-104241-01	AE-104241-01
	Touch-up Paint - Private Label Gray (Aerosol)	523014	523014	523014
	Touch-up Paint - Private Label Gray (Paint Pens)	523015	523015	523015
Coil group				
12	Replacement Coil	RCH-3021SNAVUA	RCH-4821SNAVUA	RCH-4821SNAVUA
	Horizontal Adapter Kit	See specified RCH Coil Parts List		
	Drain Pan - Vertical	See specified RCH Coil Parts List		

Blower assy

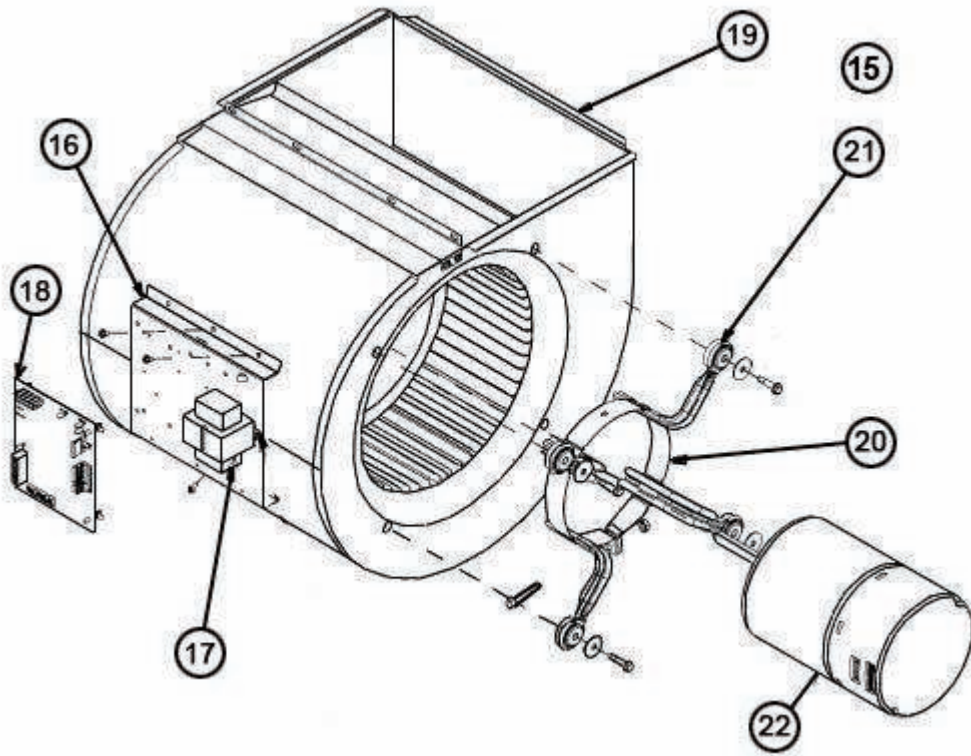

TECHNICAL DATA
AND PARTS LIST

TECHNICAL DATA
AND PARTS LIST

Item no.	Part name	Part no.		
		AMUG30LMAS	AMUG36LMAS	AMUG48LMAS
Electrical group				
17	Transformer*	46-101905-01		
18	Control Board*	9711678010	9711678027	9711678034
	Communication PCB	9710019005		
	Control board spacer	0600035037		
	Communication PCB holder	0600063023		
11	Terminal Block for Power	9306488154		
11	Terminal Block for RC/External input	9900896027		
	Thermistor (Pipe)	9901058004		
	Thermistor (Room)	9900960056		
	Wire with connector	9382318222		
	Wire with connector	9382318239		
	Wire with connector	9382318246		
	Wire with terminal	9382318253		
Blower group				
16	Mounting Bracket - Control Board	10-101049-03	10-101049-03	10-101049-03
17	Transformer	See Electrical group		
18	Control Board	See Electrical group		
19	Blower Housing w/Wheel	70-101729-02	70-101729-08	70-101729-08
	Blower Wheel*	703014	703023	703023
20	Motor Mount - Band	70-19927-04	70-19927-04	70-19927-04
21	Motor Mount - Arm (4)	70-19929-10	70-19929-10	70-19929-10
22	Blower Motor*	51-102601-01	51-102603-01	51-102603-01
23	Mounting Bracket Cover	10-101797-03	10-101797-03	10-101797-03

*: It is recommended that stock be maintained for this part.

■ RCH coil

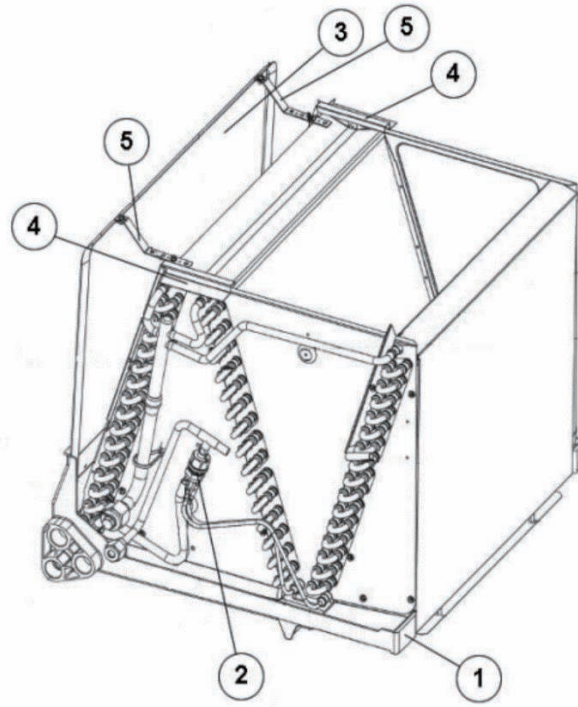

TECHNICAL DATA
AND PARTS LIST

TECHNICAL DATA
AND PARTS LIST

Item no.	Part name	Part no.		
		AMUG30LMAS	AMUG36LMAS	AMUG48LMAS
1	Drain Pan - Vertical*	68-104822-03		
2	Distributor Assembly*	83-104030-02		
	Horizontal Adapter Kit - Includes Straps, Shields, Drain Pan and Insulation	RXHH-A03		
3	Drain Pan - Horizontal	AE-101128-31		
	Insulation - Horizontal Pan	68-100528-01		
4	Rear/Front Shield (2)	AE-101136-07		
5	Straps (2)	AE-100530-07		

*: It is recommended that stock be maintained for this part.

3. Outdoor unit parts list

3-1. Model: AOUH30LUAH1

■ Exterior parts and chassis

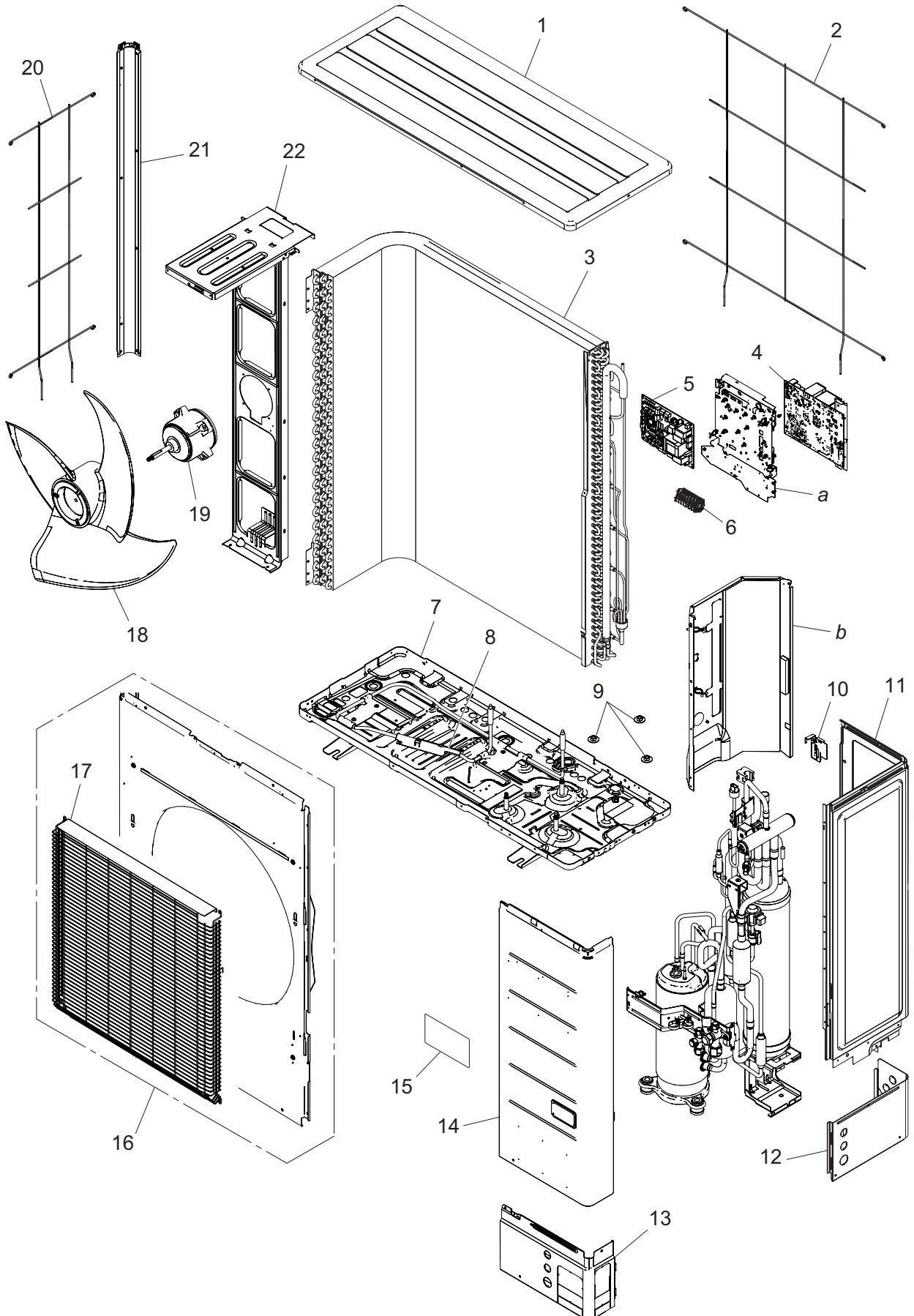

TECHNICAL DATA
AND PARTS LIST

TECHNICAL DATA
AND PARTS LIST

Item no.	Part no.	Part name	Service part
1	9379416030	Top panel sub assy	◆
2	9378926059	Protective net (Rear)	◆
3	9374420735	Condenser sub assy	◆
4	9709687208	Inverter PCB	◆
5	9711230140	Main PCB	◆
6	9900428167	Terminal	◆
7	9379425209	Base sub assy	◆
8	9900919030	Base heater	◆
9	9377973016	Special nut (M8)	◆
10	9332505009	Thermistor holder	◆
11	9380570042	Cabinet sub assy (Right)	◆
12	9384171009	Pipe cover (Rear)	◆
13	9384170002	Pipe cover (Front)	◆
14	9380571131	Service panel sub assy	◆
15	9380477006	Label (Fujitsu)	◆
	9380113027	Label (Halcyon)	◆
16	9380569107	Front panel sub assy	◆
17	9352749001	Fan guard	◆
18	9379414005	Propeller fan	◆
19	9603496012	Brushless DC motor	◆
20	9378928022	Protective net (Left)	◆
21	9380968009	Cabinet (Left)	◆
22	9380566021	Motor bracket sub assy	◆
a	—	Control box	—
b	—	Separation wall	—

Compressor

TECHNICAL DATA
AND PARTS LIST

TECHNICAL DATA
AND PARTS LIST

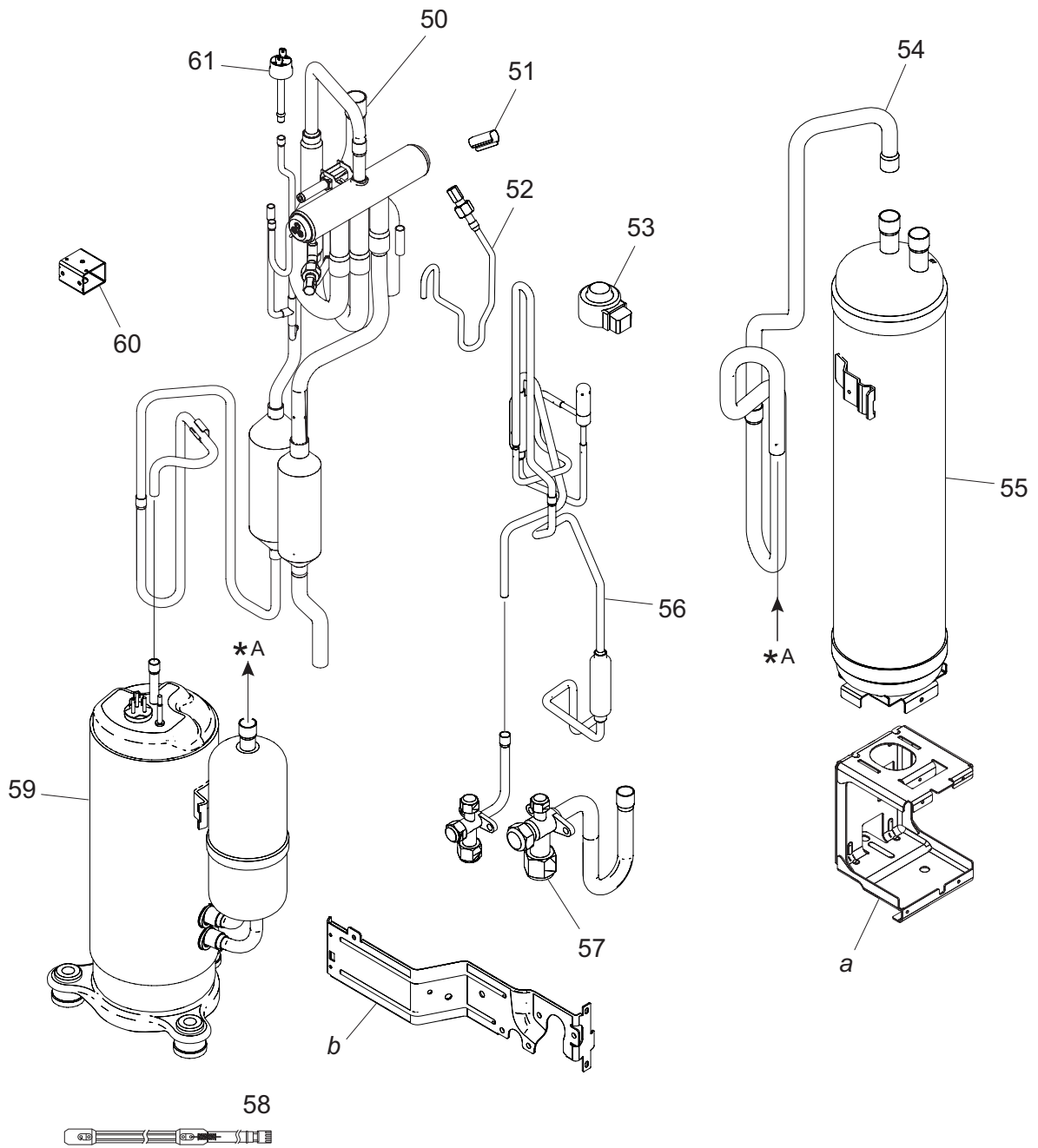

Item no.	Part no.	Part name	Service part
50	9374425747	4-way valve total assy	◆
51	9357804002	Thermostat holder	◆
52	9382230005	Fusible Plug Pipe Assy	◆
53	9970209000	Expansion valve coil	◆
54	9372514238	Suction pipe assy	◆
55	9372700075	Accumulator sub assy	◆
56	9378750395	Expansion valve total assy	◆
57	9315414045	3-way valve assy	◆
58	9901076039	Belt heater	◆
59	9810834003	Compressor	◆
60	9970110153	Solenoid	◆
61	9900186029	Pressure switch	◆
—	9379647281	Compressor cover	◆
—	9380516071	Compressor cover (Top)	◆
—	9900935078	Thermistor assy	◆
—	9900565046	Thermistor (Outdoor temp.)	◆
—	9901054013	Thermistor (Heat exchanger)	◆
—	9900985028	Thermistor (Comp)	◆
—	9901031014	Thermistor (Heatsink)	◆
—	9711198006	Wire with connector (P108—Terminal [1,2,3])	◆
—	9711203007	Wire with connector (P660—P662)	◆
—	9711204004	Wire with connector (P661—P663)	◆
—	9711205001	Wire with connector (P350—P351)	◆
—	9711212009	Wire with connector (P650—Fan motor)	◆
—	9711213006	Wire with connector (P770—Pressure SW. [joint])	◆
—	9711214010	Wire with connector (Pressure SW. [joint]—Pressure SW.)	◆
—	9712019027	Wire with terminal (P102—Terminal [L1])	◆
—	9712019034	Wire with terminal (P103—Terminal [L2])	◆
—	9711206046	Wire with terminal (P400,P401,P402—Comp.)	◆
—	9900934064	Wire with terminal (P55—Base heater)	◆
<i>a</i>	—	Installation plate (Accumulator)	—
<i>b</i>	—	Valve plate	—

3-2. Models: AOUH36LMAH1 and AOUH48LMAH1

■ Exterior parts and chassis

TECHNICAL DATA
AND PARTS LIST

TECHNICAL DATA
AND PARTS LIST

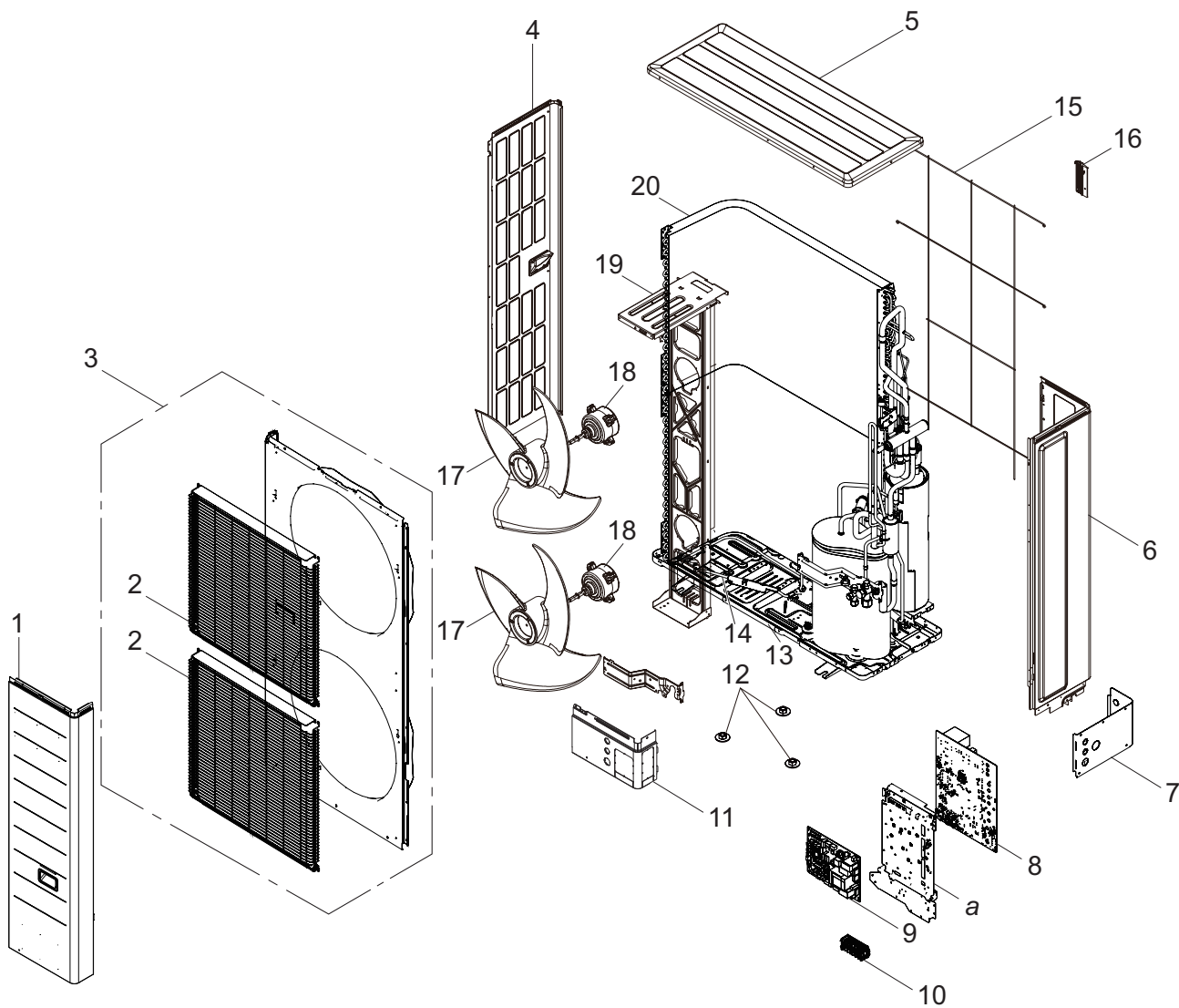

Item no.	Part no.	Part name	Service part
1	9380571148	Service panel sub assy	◆
2	9352749001	Fan guard	◆
3	9380569114	Front panel sub assy	◆
4	9380568001	Cabinet left sub assy	◆
5	9379416016	Top panel sub assy	◆
6	9380570028	Cabinet right sub assy	◆
7	9384171009	Pipe cover rear (for 36 models)	◆
	9384171016	Pipe cover rear (for 48 models)	◆
8	9709687215	Inverter PCB (service unit)	◆
9	9711230157	Main PCB (for 36 model)	◆
	9711230164	Main PCB (for 48 model)	◆
10	9900428167	Terminal	◆
11	9384170002	Pipe cover front	◆
12	9377973016	Special nut (M8)	◆
13	9379425193	Base sub assy	◆
14	9900919030	Heater (base)	◆
15	9378926042	Protective net	◆
16	9374177011	Thermo holder	◆
17	9379414005	Propeller fan	◆
18	9603794019	Motor,DC brushless	◆
19	9380566007	Motor bracket sub assy	◆
20	9380633037	Condenser sub assy	◆
—	9380477006	Label (FUJITSU)	◆
—	9380113027	Label (HALCYON)	◆
a	—	Control box unit	—

Compressor

TECHNICAL DATA
AND PARTS LIST

TECHNICAL DATA
AND PARTS LIST

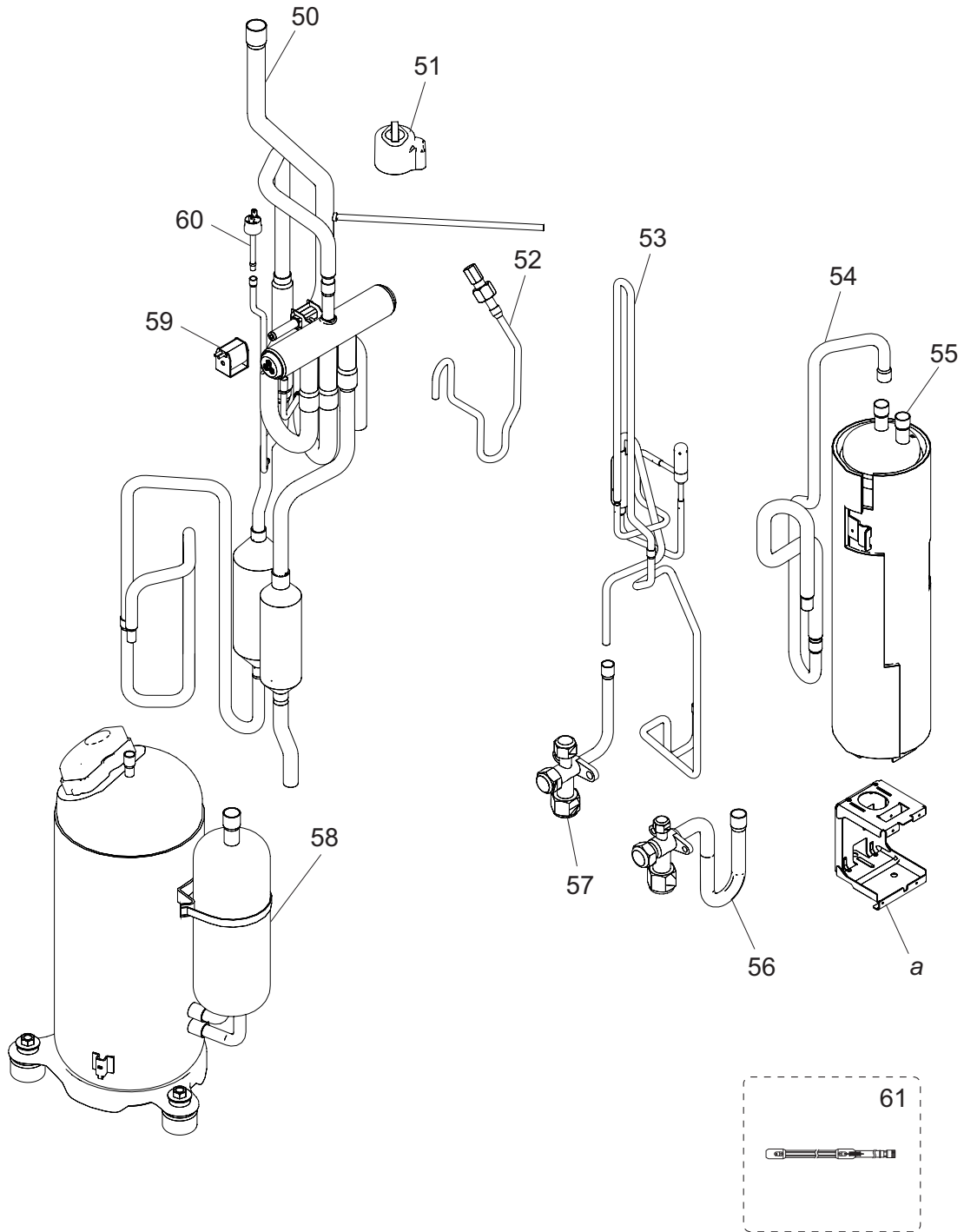









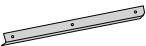

Item no.	Part no.	Part name	Service part
50	9374425730	4-way valve assy	◆
51	9970209000	Expansion valve coil	◆
52	9382230005	Fusible plug pipe assy	◆
53	9372514221	Suction pipe assy	◆
54	9372700099	Accumulator sub assy	◆
55	9378750388	Expansion valve total assy	◆
56	9315414045	3-way valve assy	◆
57	9381055005	3-way valve assy	◆
58	9374423514	Compressor sub assy	◆
59	9970110153	Solenoid	◆
60	9900186029	Pressure switch	◆
61	9901076060	Belt heater	◆
—	9380513018	Compressor cover	◆
—	9380516002	Compressor cover (Top)	◆
—	9901054013	Thermistor (Heat exchanger)	◆
—	9901031014	Thermistor (Heatsink)	◆
—	9900935078	Thermistor assy	◆
—	9900565107	Thermistor (Outdoor temp.)	◆
—	9900985028	Thermistor (Comp temp.)	◆
—	9711214010	Wire with connector (Pressure sw.[joint]—pressure sw.)	◆
—	9711213013	Wire with connector (P770—pressure sw.[joint])	◆
—	9711204004	Wire with connector (P661—P663)	◆
—	9711205018	Wire with connector (P350—P351)	◆
—	9711203007	Wire with connector (P660—P662)	◆
—	9711198037	Wire with connector (P108—terminal [1,2,3])	◆
—	9711212030	Wire with connector (PA650—fan motor 2)	◆
—	9711212023	Wire with connector (P650—fan motor 1)	◆
—	9900934064	Wire with connector (Fuse holder) (P55—base heater)	◆
—	9712019010	Wire with terminal (P103—terminal [L2])	◆
—	9711332035	Wire with terminal (P107—P201)	◆
—	9712019003	Wire with terminal (P102—terminal [L1])	◆
—	9711332028	Wire with terminal (P106—P200)	◆
—	9712103009	Wire with terminal (P400,P401,P402—COMP.)	◆
<i>a</i>	—	Installation plate (Accumulator)	—

4. Accessories

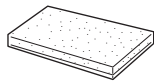
4-1. Indoor unit

■ Models: AMUG30LMAS, AMUG36LMAS, and AMUG48LMAS

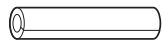
Part name	Exterior	Q'ty	Part name	Exterior	Q'ty
Operating manual		1	Cable tie (large)		4
Installation manual (indoor unit)		1	Cable tie (medium)		1
Rail		2	Cable tie (small)		1
Duct flanges		2	Drain hose insulation		1
Drain cap		2	Coupler heat insulation (large)		1
Screw		16	Coupler heat insulation (small)		1

4-2. Outdoor unit



■ Accessories

Part name	Exterior	Q'ty	Part name	Exterior	Q'ty
Installation manual		1			

5. Optional parts





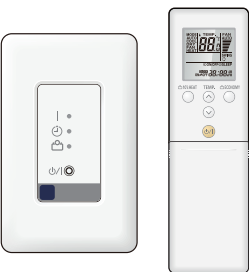

5-1. Indoor unit

■ Controllers

Exterior	Part name	Model name	Summary
	Wired remote controller	UTY-RNRUZ*	Easy finger touch operation with LCD panel. Backlit LCD enables easy operation in a dark room. Wire type: Non-polar 2-wire
	Simple remote controller	UTY-RSRY	Compact remote controller concentrates on the basic functions such as Start/Stop, fan control, temperature setting, and operation mode. Wire type: Non-polar 2-wire
	Simple remote controller	UTY-RHRY	Compact remote controller concentrates on the basic functions such as Start/Stop, fan control, and temperature setting. Wire type: Non-polar 2-wire
	IR receiver kit with wireless remote controller	UTY-LBTUM	Unit control is performed by wireless remote controller.

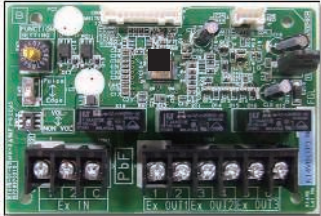
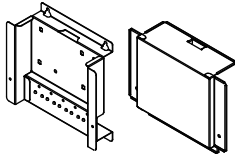
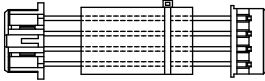
NOTE: Available functions may differ by the remote controller. For details, refer to the operation manual.

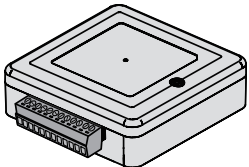
Others

Exterior	Part name	Model name	Summary
	Remote sensor unit	UTY-XSZX	Thermo-sensor for sensing the temperature of arbitrary place in the room.
	External connect kit	UTY-XWZXZG	Use to connect with various peripheral devices and air conditioner PCB. For control output port.
	External input and output PCB	UTY-XCSX	Use to connect with external devices and air conditioner PCB.
	External input and output PCB box	UTZ-GXRA	For installing the External input and output PCB.
	Wire kit	UTY-XWZXZJ	Use to connect with external input and output PCB and Indoor unit PCB.
	Wireless LAN adapter	UTY-TFSXZ2	Remotely manage an air conditioning system using mobile devices such as smartphones and tablets. For connection indoor unit with UART interface. Appropriate application for each region is required to use this option. For details, contact FGL sales company.
	Modbus converter	UTY-VMSX	For connection between indoor unit with UART interface and a Modbus open network.
	Thermostat converter	UTY-TTRX	This converter can control Fujitsu General products using a third-party thermostat controller.
	Network converter	UTY-VTGX	This converter is required when connecting single split system to VRF network system.
	External switch controller	UTY-TERX	Air conditioner switching can be controlled by connecting other external sensor switches.

NOTE: Combined use of following optional parts and Wireless LAN adapter (UTY-TFSXZ2) is not allowed.

- External input and output PCB (UTY-XCSX)
- Modbus converter
- Thermostat converter

6. Refrigerant system diagrams

6-1. Models: AOUH30LUAH1, AOUH36LMAH1, and AOUH48LMAH1

TECHNICAL DATA
AND PARTS LIST

TECHNICAL DATA
AND PARTS LIST

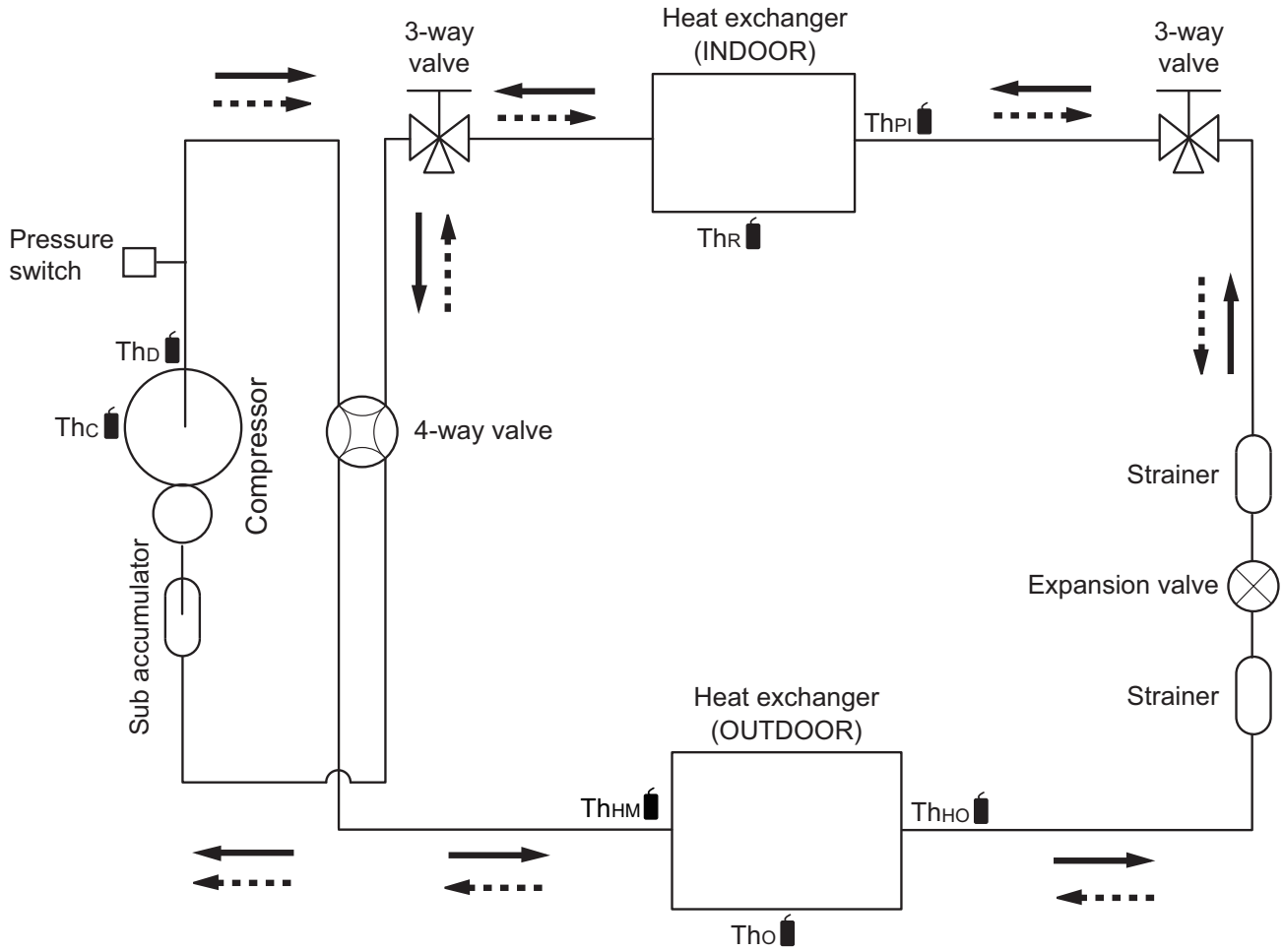

————— : Cooling
 - - - - - : Heating

- Thc : Thermistor (Compressor temperature)
- ThD : Thermistor (Discharge temperature)
- ThHM : Thermistor (Heat exchanger middle temperature)
- Tho : Thermistor (Outdoor temperature)
- ThHO : Thermistor (Heat exchanger out temperature)
- ThPI : Thermistor (Pipe temperature)
- ThR : Thermistor (Room temperature)

7. Wiring diagrams

7-1. Indoor unit

Models: AMUG30LMAS, AMUG36LMAS, and AMUG48LMAS

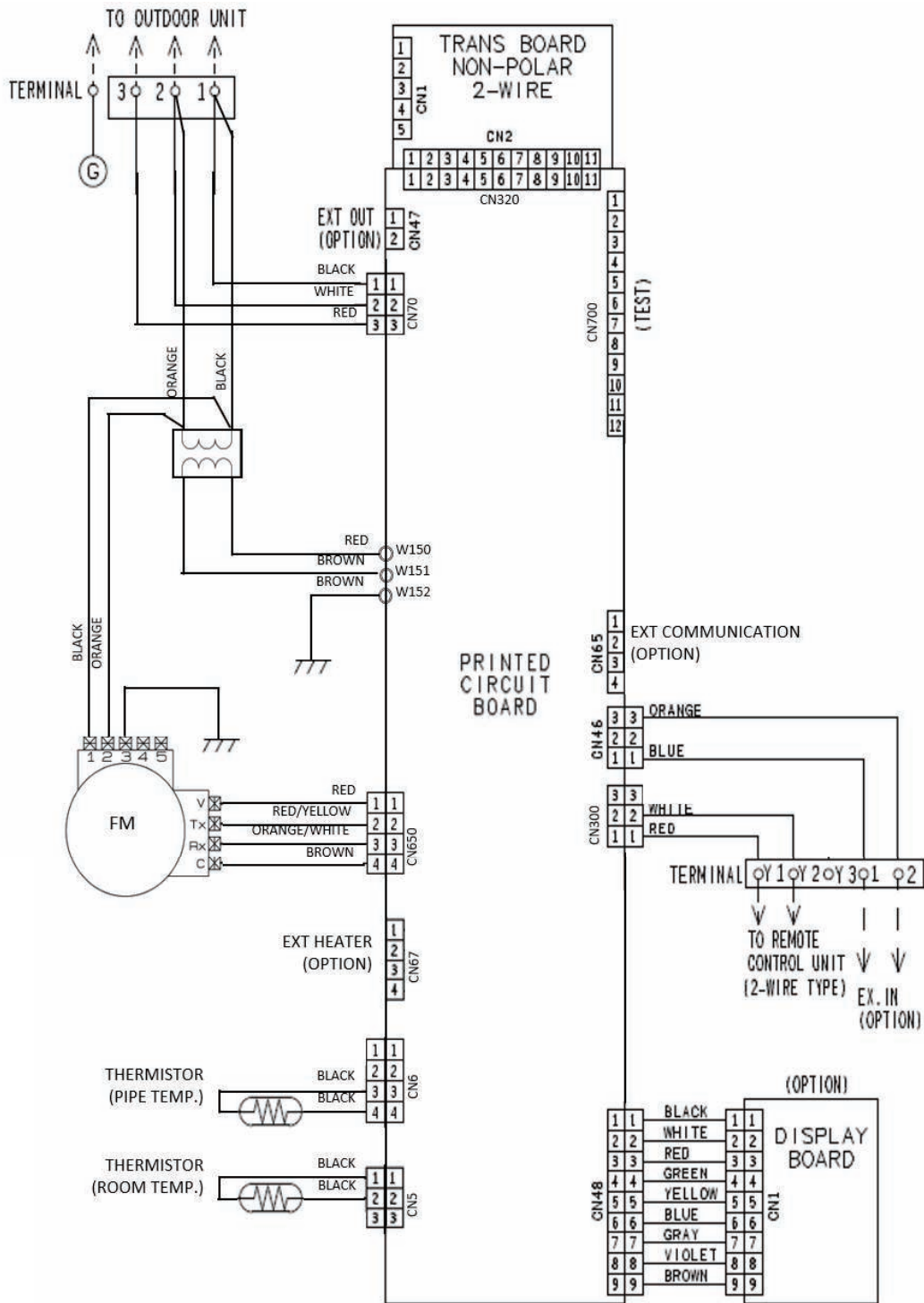

TECHNICAL DATA
AND PARTS LIST

TECHNICAL DATA
AND PARTS LIST

7-2. Outdoor unit

Model: AOUH30LUAH1

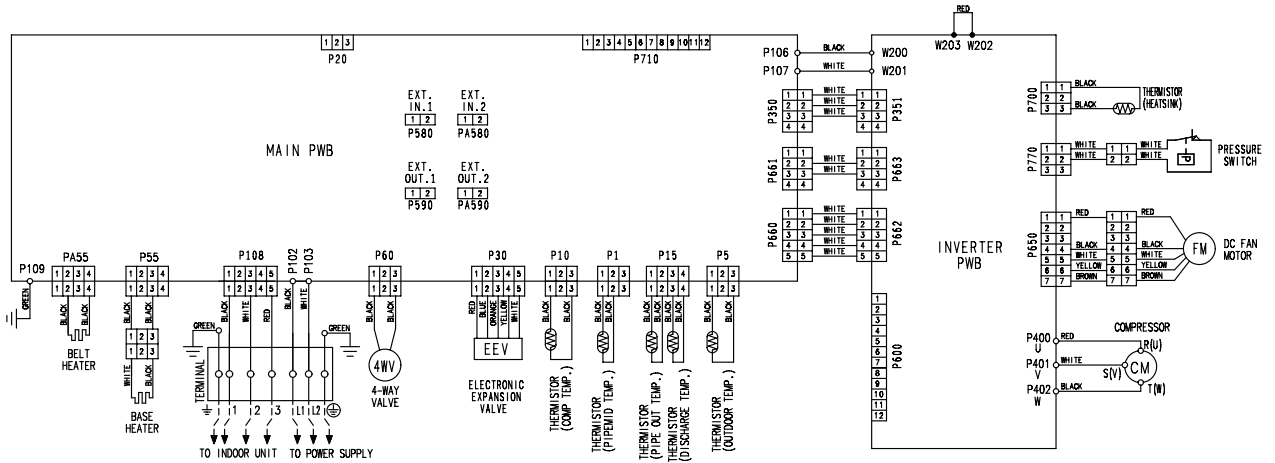

Models: AOUH36LMAH1 and AOUH48LMAH1

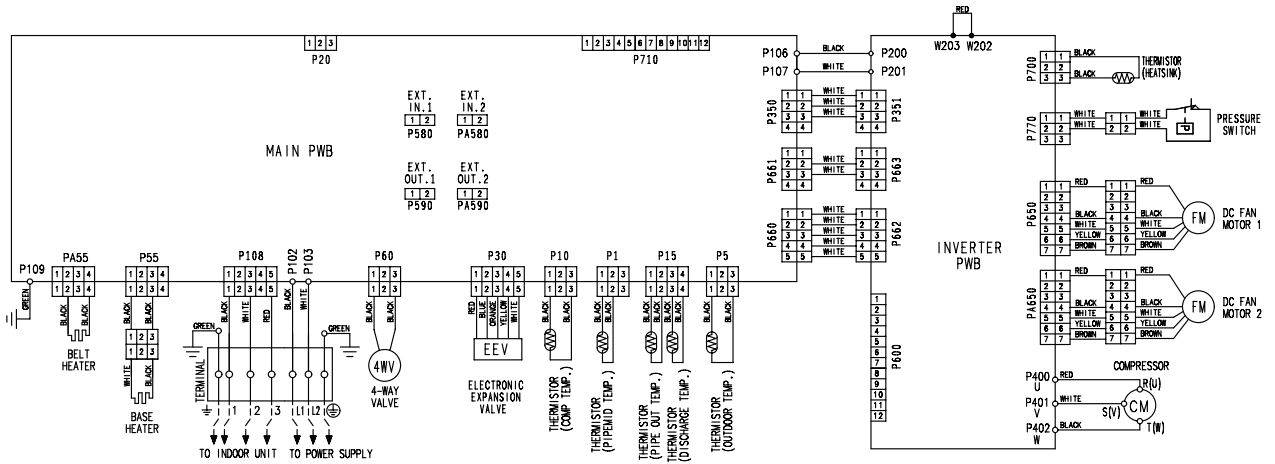

TECHNICAL DATA AND PARTS LIST

TECHNICAL DATA AND PARTS LIST

8. PC board diagrams

8-1. Models: AMUG30LMAS, AMUG36LMAS, and AMUG48LMAS

TECHNICAL DATA AND PARTS LIST

TECHNICAL DATA AND PARTS LIST

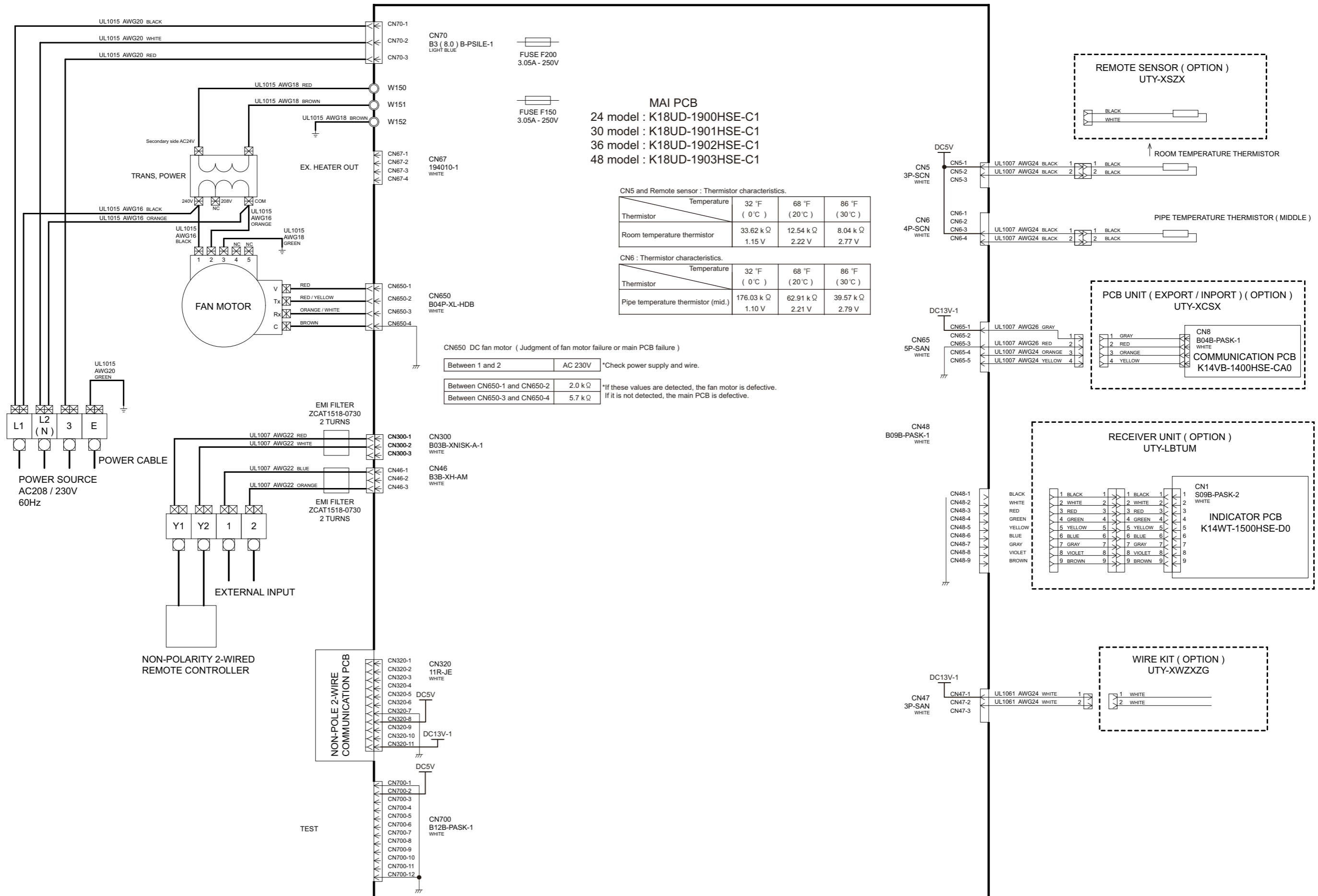

8-2. Model: AOUH30LUAH1

INVERTER ASSEMBLY 30 model : EZ-0215HUE

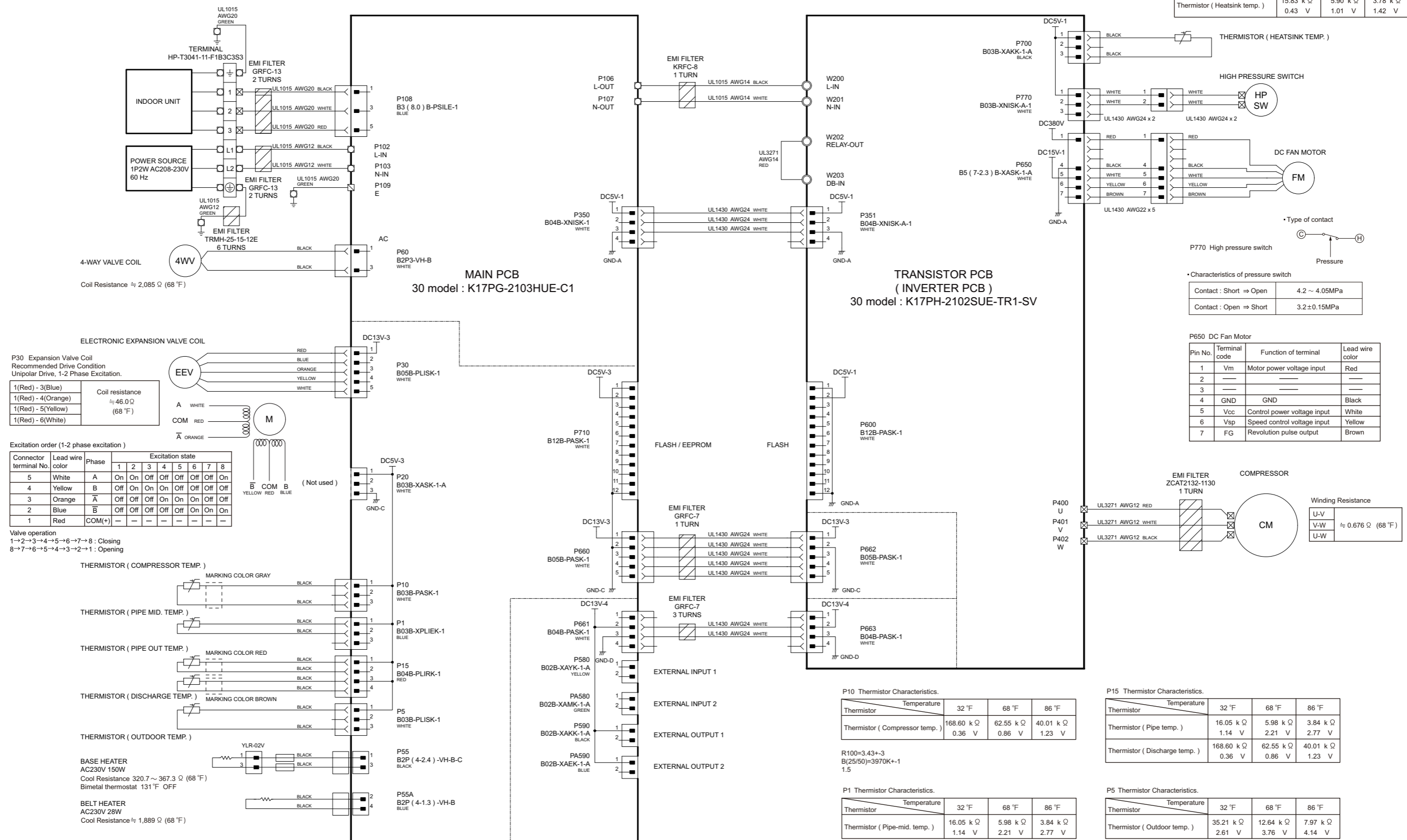

P700 Thermistor Characteristics.

Thermistor	Temperature	32 °F	68 °F	86 °F
Thermistor		15.83 k Ω	5.90 k Ω	3.78 k Ω
Thermistor (Heatsink temp.)		0.43 V	1.01 V	1.42 V

P30 Expansion Valve Coil
Recommended Drive Condition
Unipolar Drive, 1-2 Phase Excitation.

Coil resistance	Lead wire color
≈ 46.0 Ω (68 °F)	1(Blue) - 3(Blue)
	1(Blue) - 4(Orange)
	1(Blue) - 5(Yellow)
	1(Blue) - 6(White)

Excitation order (1-2 phase excitation)

Connector terminal No.	Lead wire color	Phase	Excitation state								
			1	2	3	4	5	6	7	8	
5	White	A	On	On	Off	Off	Off	Off	Off	Off	On
4	Yellow	B	Off	On	On	On	Off	Off	Off	Off	Off
3	Orange	Ā	Off	Off	Off	On	On	On	On	Off	Off
2	Blue	B̄	Off	Off	Off	Off	Off	Off	On	On	On
1	Red	COM(+)	-	-	-	-	-	-	-	-	-

Valve operation
1→2→3→4→5→6→7→8 : Closing
8→7→6→5→4→3→2→1 : Opening

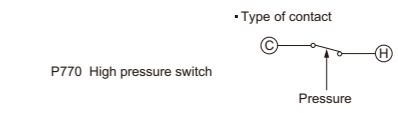

Characteristics of pressure switch

Contact : Short ⇒ Open	4.2 ~ 4.05MPa
Contact : Open ⇒ Short	3.2±0.15MPa

P650 DC Fan Motor

Pin No.	Terminal code	Function of terminal	Lead wire color
1	Vm	Motor power voltage input	Red
2			
3			
4	GND	GND	Black
5	Vcc	Control power voltage input	White
6	Vsp	Speed control voltage input	Yellow
7	FG	Revolution pulse output	Brown

Winding Resistance

U-V	≈ 0.676 Ω (68 °F)
V-W	
U-W	

P10 Thermistor Characteristics.

Thermistor	Temperature	32 °F	68 °F	86 °F
Thermistor (Compressor temp.)		168.60 k Ω	62.55 k Ω	40.01 k Ω
		0.36 V	0.86 V	1.23 V

R100=3.43+3
B(25/50)=3970K+-1.5

P1 Thermistor Characteristics.

Thermistor	Temperature	32 °F	68 °F	86 °F
Thermistor (Pipe-mid. temp.)		16.05 k Ω	5.98 k Ω	3.84 k Ω
		1.14 V	2.21 V	2.77 V

P15 Thermistor Characteristics.

Thermistor	Temperature	32 °F	68 °F	86 °F
Thermistor (Pipe temp.)		16.05 k Ω	5.98 k Ω	3.84 k Ω
Thermistor (Discharge temp.)		168.60 k Ω	62.55 k Ω	40.01 k Ω
		0.36 V	0.86 V	1.23 V

P5 Thermistor Characteristics.

Thermistor	Temperature	32 °F	68 °F	86 °F
Thermistor (Outdoor temp.)		35.21 k Ω	12.64 k Ω	7.97 k Ω
		2.61 V	3.76 V	4.14 V

8-3. Models: AOUH36LMAH1 and AOUH48LMAH1

INVERTER ASSEMBLY
 36 model : EZ-0216HUE
 48 model : EZ-0217HUE

TECHNICAL DATA
AND PARTS LIST

TECHNICAL DATA
AND PARTS LIST

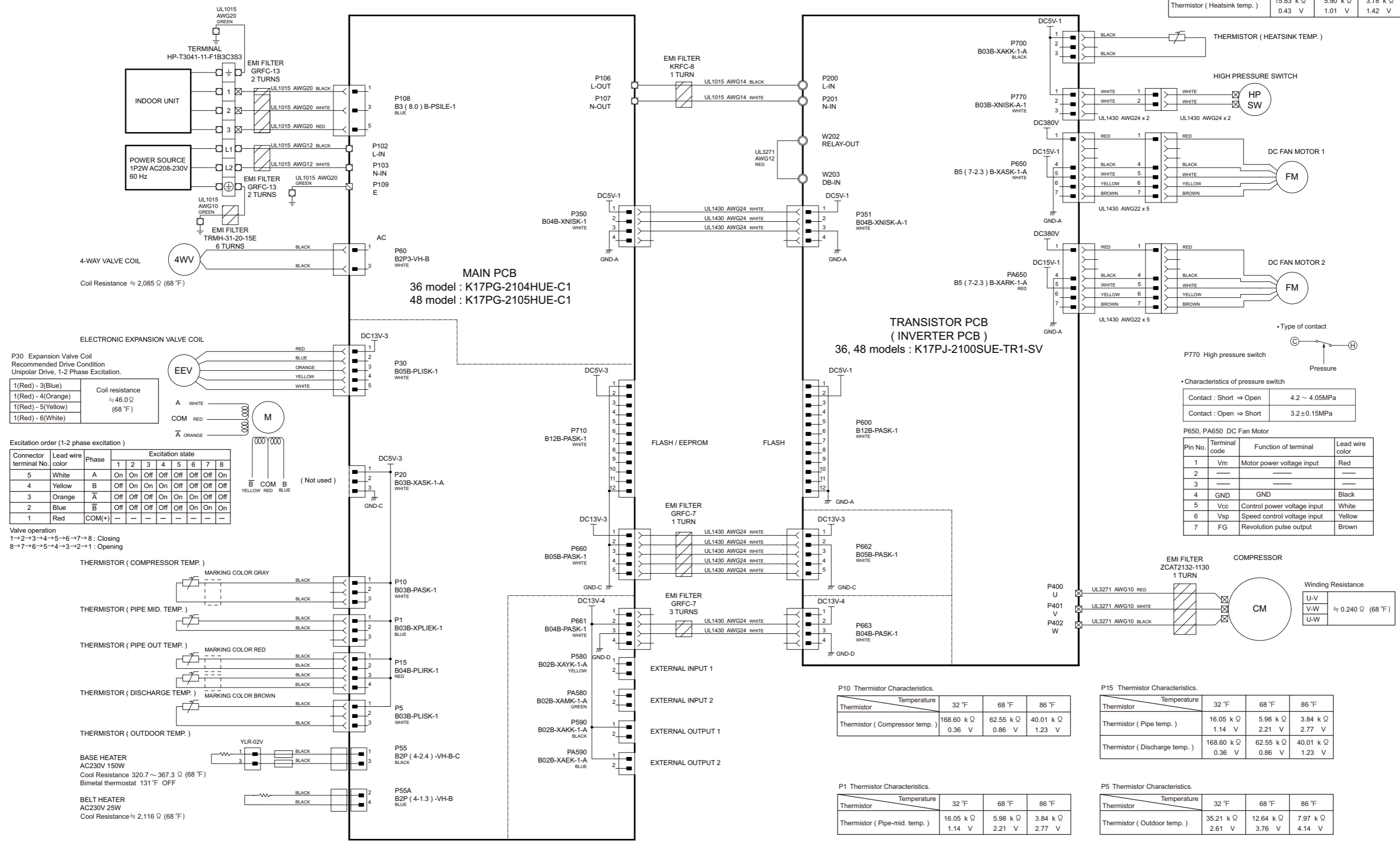

3. TROUBLESHOOTING

CONTENTS

3. TROUBLESHOOTING

1. Error code	03-1
1-1. How to check the error memory.....	03-1
1-2. How to erase the error memory	03-1
1-3. Error code table (Indoor unit and wired remote controller).....	03-2
1-4. Error code table (Outdoor unit).....	03-4
2. Troubleshooting with error code	03-6
2-1. E: 11.X. Serial communication error (Serial reverse transfer error) (Outdoor unit)	03-6
2-2. E: 11.X. Serial communication error (Serial forward transfer error) (Indoor unit)	03-8
2-3. E: 12.X. Wired remote controller communication error (Indoor unit)	03-10
2-4. E: 18.X. External communication error (Indoor unit)	03-11
2-5. E: 23.X. Combination error (Outdoor unit)	03-12
2-6. E: 26.X. Address setting error in wired remote controller (Indoor unit)	03-13
2-7. E: 29.X. Connected unit number error (Indoor unit)	03-14
2-8. E: 32.X. Indoor unit main PCB error (Indoor unit)	03-15
2-9. E: 35.X. MANUAL AUTO button error (Indoor unit)	03-16
2-10. E: 3A.X. Indoor unit communication circuit error (Indoor unit).....	03-17
2-11. E: 41.X. Room temperature sensor error (Indoor unit).....	03-18
2-12. E: 42.X. Indoor unit heat exchanger sensor error (Indoor unit).....	03-19
2-13. E: 51.X. Indoor unit fan motor error (Indoor unit)	03-20
2-14. E: 62.X. Outdoor unit main PCB error (Outdoor unit).....	03-21
2-15. E: 63.X. Inverter error (Outdoor unit)	03-22
2-16. E: 65.X. IPM error (Outdoor unit).....	03-23
2-17. E: 71.X. Discharge thermistor error (Outdoor unit)	03-25
2-18. E: 72.X. Compressor thermistor error (Outdoor unit)	03-26
2-19. E: 73.X. Heat exchanger (Middle/Outlet) temperature thermistor error (Outdoor unit).....	03-27
2-20. E: 74.X. Outdoor temperature thermistor error (Outdoor unit)	03-28
2-21. E: 77.X. Heat sink thermistor error (Outdoor unit)	03-29
2-22. E: 84.X. Current sensor error (Outdoor unit).....	03-30
2-23. E: 86.X. High pressure switch error (Outdoor unit)	03-31
2-24. E: 94.X. Trip detection (Outdoor unit)	03-32
2-25. E: 95.X. Compressor motor control error (Outdoor unit).....	03-33
2-26. E: 97.X. Outdoor unit fan motor error (Outdoor unit).....	03-34
2-27. E: 99.X. 4-way valve error (Outdoor unit)	03-35
2-28. E: 9A.X. Coil (Expansion valve) error	03-37
2-29. E: A1.X. Discharge temperature error (Outdoor unit).....	03-38
2-30. E: A3.X. Compressor temperature error (Outdoor unit)	03-40
2-31. E: AC.X. Heat sink temperature error (Outdoor unit)	03-42
3. Troubleshooting without error code	03-43
3-1. Indoor unit—No power.....	03-43
3-2. Outdoor unit—No power	03-44
3-3. No operation (Power is on).....	03-45

CONTENTS (continued)

3-4. No cooling/No heating	03-46
3-5. Abnormal noise.....	03-48
3-6. Water leaking.....	03-49
4. Service parts information	03-50
4-1. Compressor	03-50
4-2. Inverter compressor.....	03-51
4-3. Outdoor unit Electronic Expansion Valve (EEV)	03-53
4-4. Outdoor unit fan motor.....	03-55
5. Thermistor resistance values.....	03-56
5-1. Indoor unit	03-56
5-2. Outdoor unit.....	03-57

1. Error code

When a problem occurs in the system or the connected device, the error content is notified by displaying the code.

NOTE: This function is only available in a system with indoor or IR receiver units equipped with LED lamps to indicate the error content.

Errors, once displayed, will be automatically stored in the PC board of the indoor unit. Even if the power is disconnected, the memory containing the error history will not be erased.

If another error occurs later, the stored error memory will be updated automatically and replaced with the new one. (Previous error will be erased.)

1-1. How to check the error memory

When an error occurs, the operation lamp (Green) and the timer lamp (Orange) indicate the error content by blinking. To check the error memory, follow the procedures below.

1. Stop the operation of the air conditioner, and then disconnect the power supply.
2. Reconnect the power supply.
3. In one of the following two methods, the memorized error is only displayed during the “3 minutes ST”^{*} state period.
 - Start the operation and then press the TEST RUN button on the remote controller.
 - Press the MANUAL AUTO button on the indoor unit for 10 seconds or more.

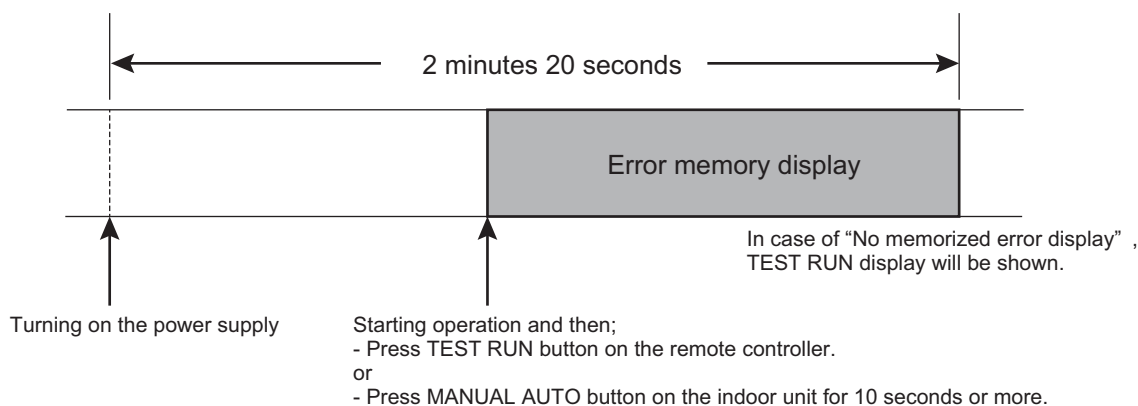

*: The “3 minutes ST” period lasts 2 minutes and 20 seconds after turning on the power supply.

1-2. How to erase the error memory

The error memory can be erased in one of the following two methods.

- Manual erase: Pressing the MANUAL AUTO button on the indoor unit while the “Error memory display” is being shown. (Short beep emits for about 3 seconds.)
- Automatic erase: After continuing the normal operation of the air conditioner without error for 2 hours or longer after displaying the error memory as described in [How to check the error memory](#). (Except FAN operation mode.)

1-3. Error code table (Indoor unit and wired remote controller)

The operation, timer, and economy indicators operate according to the error contents.

For confirmation of the error contents, refer the flashing pattern as follows.

Error contents	Indoor unit display			Wired remote controller display
	Operation [I] (Green)	Timer [⌚] (Orange)	Economy [E] (Green)	
E: 11.X. Serial communication error (Serial reverse transfer error) (Outdoor unit)	1 times	1 times	Continuous	11
E: 11.X. Serial communication error (Serial forward transfer error) (Indoor unit)	1 times	1 times	Continuous	11
E: 12.X. Wired remote controller communication error (Indoor unit)	1 times	2 times	Continuous	12
E: 18.X. External communication error (Indoor unit)	1 times	8 times	Continuous	18
E: 23.X. Combination error (Outdoor unit)	2 times	3 times	Continuous	23
E: 26.X. Address setting error in wired remote controller (Indoor unit)	2 times	6 times	Continuous	26
E: 29.X. Connected unit number error (Indoor unit)	2 times	9 times	Continuous	29
E: 32.X. Indoor unit main PCB error (Indoor unit)	3 times	2 times	Continuous	32
E: 35.X. MANUAL AUTO button error (Indoor unit)	3 times	5 times	Continuous	35
E: 3A.X. Indoor unit communication circuit error (Indoor unit)	3 times	10 times	Continuous	3A
E: 41.X. Room temperature sensor error (Indoor unit)	4 times	1 times	Continuous	41
E: 42.X. Indoor unit heat exchanger sensor error (Indoor unit)	4 times	2 times	Continuous	42
E: 51.X. Indoor unit fan motor error (Indoor unit)	5 times	1 times	Continuous	51
E: 62.X. Outdoor unit main PCB error (Outdoor unit)	6 times	2 times	Continuous	62
E: 63.X. Inverter error (Outdoor unit)	6 times	3 times	Continuous	63
E: 65.X. IPM error (Outdoor unit)	6 times	5 times	Continuous	65
E: 71.X. Discharge thermistor error (Outdoor unit)	7 times	1 times	Continuous	71
E: 72.X. Compressor thermistor error (Outdoor unit)	7 times	2 times	Continuous	72
E: 73.X. Heat exchanger (Middle/Outlet) temperature thermistor error (Outdoor unit)	7 times	3 times	Continuous	73
E: 74.X. Outdoor temperature thermistor error (Outdoor unit)	7 times	4 times	Continuous	74
E: 77.X. Heat sink thermistor error (Outdoor unit)	7 times	7 times	Continuous	77
E: 84.X. Current sensor error (Outdoor unit)	8 times	4 times	Continuous	84
E: 86.X. High pressure switch error (Outdoor unit)	8 times	6 times	Continuous	86
E: 94.X. Trip detection (Outdoor unit)	9 times	4 times	Continuous	94
E: 95.X. Compressor motor control error (Outdoor unit)	9 times	5 times	Continuous	95
E: 97.X. Outdoor unit fan motor error (Outdoor unit)	9 times	7 times	Continuous	97
E: 99.X. 4-way valve error (Outdoor unit)	9 times	9 times	Continuous	99
E: 9A.X. Coil (Expansion valve) error	9 times	10 times	Continuous	9A
E: A1.X. Discharge temperature error (Outdoor unit)	10 times	1 times	Continuous	A1

Error contents	Indoor unit display			Wired remote controller display
	Operation [I] (Green)	Timer [⏰] (Orange)	Economy [E] (Green)	
E: A3.X. Compressor temperature error (Outdoor unit)	10 times	3 times	Continuous	A3
E: AC.X. Heat sink temperature error (Outdoor unit)	10 times	12 times	Continuous	AC

1-4. Error code table (Outdoor unit)

The operation status is determined by the lighting up and blinking of the LED lamp.

After check that ERROR LED lamp blinks, press the ENTER button once.

NOTE: For the positions of LED lamp and buttons, refer to "Function settings Function settings (For outdoor unit)" in Chapter 5. FIELD WORKING on page 05-10.

Error contents	POWER/ MODE	ERROR	PUMP DOWN	LOW NOISE		PEAK CUT		
			L1	L2	L3	L4	L5	L6
E: 11.X. Serial communication error (Serial forward transfer error) (Indoor unit) (Occurs immediately after starting operation)	■ 2	●	■ 1	■ 1	○	○	●	●
E: 11.X. Serial communication error (Serial forward transfer error) (Indoor unit) (Occurs during operation)	■ 2	●	■ 1	■ 1	○	●	○	○
E: 12.X. Wired remote controller communication error (Indoor unit)	■ 2	●	■ 5	■ 15	○	○	○	●
E: 18.X. External communication error (Indoor unit)	■ 2	●	■ 5	■ 15	○	○	○	●
E: 23.X. Combination error (Outdoor unit)	■ 2	●	■ 5	■ 15	○	○	○	●
E: 26.X. Address setting error in wired remote controller (Indoor unit)	■ 2	●	■ 5	■ 15	○	○	○	●
E: 29.X. Connected unit number error (Indoor unit)	■ 2	●	■ 5	■ 15	○	○	○	●
E: 32.X. Indoor unit main PCB error (Indoor unit)	■ 2	●	■ 5	■ 15	○	○	○	●
E: 3A.X. Indoor unit communication circuit error (Indoor unit)	■ 2	●	■ 5	■ 15	○	○	○	●
E: 41.X. Room temperature sensor error (Indoor unit)	■ 2	●	■ 5	■ 15	○	○	○	●
E: 42.X. Indoor unit heat exchanger sensor error (Indoor unit)	■ 2	●	■ 5	■ 15	○	○	○	●
E: 51.X. Indoor unit fan motor error (Indoor unit)	■ 2	●	■ 5	■ 15	○	○	○	●
E: 62.X. Outdoor unit main PCB error (Outdoor unit)	■ 2	●	■ 6	■ 2	○	○	○	●
E: 63.X. Inverter error (Outdoor unit)	■ 2	●	■ 6	■ 3	○	○	○	●
E: 65.X. IPM error (Outdoor unit)	■ 2	●	■ 6	■ 5	○	○	●	●
E: 71.X. Discharge thermistor error (Outdoor unit)	■ 2	●	■ 7	■ 1	○	○	○	●
E: 72.X. Compressor thermistor error (Outdoor unit)	■ 2	●	■ 7	■ 2	○	○	○	●
E: 73.X. Heat exchanger (Middle/Outlet) temperature thermistor error (Outdoor unit)	■ 2	●	■ 7	■ 3	○	○	●	○
E: 74.X. Outdoor temperature thermistor error (Outdoor unit)	■ 2	●	■ 7	■ 4	○	○	○	●
E: 77.X. Heat sink thermistor error (Outdoor unit)	■ 2	●	■ 7	■ 7	○	○	○	●
E: 84.X. Current sensor error (Outdoor unit)	■ 2	●	■ 8	■ 4	○	○	○	●
E: 94.X. Trip detection (Outdoor unit)	■ 2	●	■ 9	■ 4	○	○	○	●

Error contents	POWER/ MODE	ERROR	PUMP DOWN	LOW NOISE			PEAK CUT		
			L1	L2	L3	L4	L5	L6	
E: 95.X. Compressor motor control error (Outdoor unit)	■ 2	●	■ 9	■ 5	○	○	○	●	
E: 97.X. Outdoor unit fan motor error (Outdoor unit)	■ 2	●	■ 9	■ 7	○	○	●	●	
E: 99.X. 4-way valve error (Outdoor unit)	■ 2	●	■ 9	■ 9	○	○	○	●	
E: 9A.X. Coil (Expansion valve) error	■ 2	●	■ 9	■ 10	○	○	○	●	
E: A1.X. Discharge temperature error (Outdoor unit)	■ 2	●	■ 10	■ 1	○	○	○	●	
E: A3.X. Compressor temperature error (Outdoor unit)	■ 2	●	■ 10	■ 3	○	○	○	●	
E: AC.X. Heat sink temperature error (Outdoor unit)	■ 2	●	■ 10	■ 12	○	○	●	●	

● : Light on ○ : Light off ■ (n) : n Times blinking

2. Troubleshooting with error code

2-1. E: 11.X. Serial communication error (Serial reverse transfer error) (Outdoor unit)

Indicator	Indoor unit	Operation indicator	1 time flash
		Timer indicator	1 time flash
		Economy indicator	Continuous flash
		Error code	E: 11
	outdoor unit	Refer to " Error code table (Outdoor unit) " on page 03-4	
Detective actuator	Outdoor unit	Main PCB	When the indoor unit cannot receive the serial signal from outdoor unit more than 2 minutes after power on, or the indoor unit cannot receive the serial signal more than 15 seconds during normal operation.
		Fan motor	
Forecast of cause		Connection failure	
		External cause	
		Main PCB failure	
		Outdoor unit fan motor failure	

Check point 1. Reset the power and operate

Does error indication show again?

→ If no, go to "[Check point 1-2](#)".



Check point 2. Check connection

Check any loose or removed connection line of indoor unit and outdoor unit.

Check connection condition is control unit. (If there is loose connector, open cable or mis-wiring.)

→ If there is an abnormal condition, correct it by referring to the installation manual or the "DESIGN & TECHNICAL MANUAL".



Check point 3. Check the voltage of power supply

Check the voltage of power supply

Check if AC 187 V (AC 208 V -10%) to AC 253 V (AC 230 V +10%) appears at outdoor unit terminal L1 — L2.

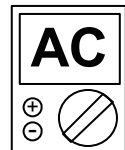

Check point 4. Check serial signal (Reverse transfer signal)

Check serial signal (Reverse transfer signal)

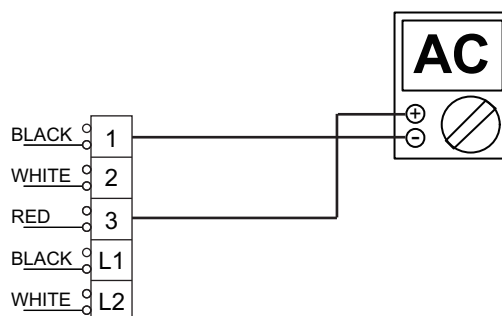

- Check if indicated value swings between AC 90 V and AC 270 V at the outdoor unit terminal 1—3.
- If it is abnormal, check the parts below.
 - Outdoor unit fan motor in "[Service parts information](#)" on page 03-50
- If outdoor fan motor is abnormal, replace outdoor unit fan motor and main PCB.
- If the checked parts are normal, replace the main PCB.



End

Check point 1-2. Check external cause such as noise

- Check the complete insulation of the grounding.
- Check if there is any equipment that causes harmonic wave near the power cable (Neon light bulb or any electronic equipment which causes harmonic wave).



End

2-2. E: 11.X. Serial communication error (Serial forward transfer error) (Indoor unit)

Indicator	Indoor unit	Operation indicator	1 time flash
		Timer indicator	1 time flash
		Economy indicator	Continuous flash
		Error code	E: 11
	outdoor unit	Refer to " Error code table (Outdoor unit) " on page 03-4	
Detective actuator	Indoor unit	Main PCB	When the outdoor unit cannot properly receive the serial signal from indoor unit for 10 seconds or more.
		Fan motor	
	Outdoor unit	Main PCB	
Forecast of cause			Connection failure
			External cause
			Main PCB failure

Check point 1. Reset the power and operate

Does error indication show again?

→ If no, go to "[Check point 1-2](#)".



Check point 2. Check connection

Check any loose or removed connection line of indoor unit and outdoor unit.

→ If there is an abnormal condition, correct it by referring to the installation manual or the "DESIGN & TECHNICAL MANUAL".

Check connection condition is control unit. (If there is loose connector, open cable or mis-wiring.)



Check point 3. Check the voltage of power supply

Check the voltage of power supply

Check if AC 187 V (AC 208 V -10%) to AC 253 V (AC 230 V +10%) appears at outdoor unit terminal L1 — L2.



Check point 4. Check serial signal (Forward transfer signal)

Check serial signal (Forward transfer signal)

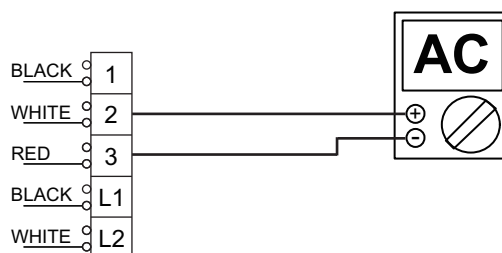

- Check if indicated value swings between AC 30 V and AC 130 V at outdoor unit terminal 2—3.
- If it is abnormal, replace main PCB.



End

Check point 1-2. Check external cause such as noise

- Check if the ground connection is proper.
- Check if there is any equipment that causes harmonic wave near the power cable (Neon light bulb or any electronic equipment which causes harmonic wave).



End

2-3. E: 12.X. Wired remote controller communication error (Indoor unit)

Indicator	Indoor unit	Operation indicator	1 time flash
		Timer indicator	2 time flash
		Economy indicator	Continuous flash
		Error code	E: 12
	outdoor unit	Refer to " "Error code table (Outdoor unit)" " on page 03-4	
Detective actuator	Indoor unit	Main PCB	When the indoor unit cannot receive the signal from wired remote controller more than following time during normal operation. <ul style="list-style-type: none"> • 3-wire type: 1 minute • 2-wire type: 2.5 minutes
	Wired remote control		
Forecast of cause			Terminal connection abnormal
			Wired remote control failure
			Main PCB failure

Check point 1. Check the connection of terminal

After turning off the power, check & correct the followings.

- Check the connection of terminal between wired remote controller and indoor unit, and check if there is a disconnection of the cable.



Check Point 1-2 : Check Wired remote controller and main PCB

Check voltage at CN300 of main PCB.
(Power supply to the remote controller)
Upon correcting the removed connector or mis-wiring, reset the power.



- If it is DC 12 V, remote controller is failure. (Main PCB is normal)
 - Replace remote control
- If it is DC 0 V, main PCB is failure. (Check remote controller once again)
 - Replace main PCB



End

Check Point 2 : Wire installation wrong remote controller group setting

- Wrong wire connection in remote controller group (Please refer to the installation manual)
- The number of connecting indoor unit and remote controller in one remote controller group were less than 16 units.



Check Point 2-1 : Check Indoor unit main PCB

- Check if main PCB damage
- Change main PCB and check the error after setting remote controller address



End

2-4. E: 18.X. External communication error (Indoor unit)

Indicator	Indoor unit	Operation indicator	1 time flash
		Timer indicator	8 time flash
		Economy indicator	Continuous flash
		Error code	E: 18
	outdoor unit		Refer to " Error code table (Outdoor unit) " on page 03-4
Detective actuator	Indoor unit	External communication error	After receiving a signal from the external input and output PCB, the same signal has not been received for 15 seconds.
Forecast of cause			Connection failure
			External input and output PCB failure
			Main PCB

Check point 1. Check the connection

- Check any loose or removed connection between the main PCB to the external input and output PCB.
-> If there is an abnormal condition, correct it by refer to the installation manual or the "DESIGN & TECHNICAL MANUAL".
- Check the connection condition on the external input and output PCB and the main PCB (If there is loose connector, open cable or mis-wiring.)



Check point 2. Replace the external input and output PCB

If check point 1 do not improve the symptom, change external input and output PCB.



Check point 3. Replace main PCB

If check point 2 do not improve the symptom, change main PCB



End

2-5. E: 23.X. Combination error (Outdoor unit)

Indicator	Indoor unit	Operation indicator	2 time flash
		Timer indicator	3 time flash
		Economy indicator	Continuous flash
		Error code	E: 23
	Outdoor unit	Refer to " Error code table (Outdoor unit) " on page 03-4	
Detective actuator	Indoor unit	The outdoor unit receives the serial signal of applied refrigerant information from indoor unit.	
Forecast of cause		Incorrect indoor unit is selected.	

Check point 1. Check the type of indoor unit

- Check the type of the connected indoor unit.
-> If there is an abnormal condition, correct it by refer to the installation manual or the "DESIGN & TECHNICAL MANAL".



Check point 2. Replace main PCB

If check point 1 do not improve the symptom, replace main PCB of the outdoor unit.



End

2-6. E: 26.X. Address setting error in wired remote controller (Indoor unit)

Indicator	Indoor unit	Operation indicator	2 time flash
		Timer indicator	6 time flash
		Economy indicator	Continuous flash
		Error code	E: 26
	outdoor unit	Refer to " Error code table (Outdoor unit) " on page 03-4	
Detective actuator	Wired remote controller (2-wire)	<ul style="list-style-type: none"> When the address number set by auto setting and manual setting are mixed in one remote controller group When the duplicated address number exists in one remote controller group 	
	Indoor unit controller PCB		
Forecast of cause			Wrong wiring of remote controller group
			Wrong remote controller address setting
			Indoor unit main PCB failure
			Remote controller failure

Check point 1. Wire installation

- Check the wire connection in the remote controller group (For installation method, refer to installation manual)
-> If there is an abnormal condition, correct it by refer to the installation manual or the "DESIGN & TECHNICAL MANUAL".



Check point 2. Wrong remote controller group setting

- The given address number by auto setting (00) and the manual set number (except 00) are not existing in one remote controller group.
- The remote controller address setting by UI is not existing same address.
- The duplicate address number is not existing in one remote controller group.



Check point 3. Check indoor unit main PCB

- Check if main PCB is damaged.
- Change main PCB and check the error after setting remote controller address.



End

2-7. E: 29.X. Connected unit number error (Indoor unit)

Indicator	Indoor unit	Operation indicator	2 time flash
		Timer indicator	9 time flash
		Economy indicator	Continuous flash
		Error code	E: 29
	outdoor unit	Refer to " Error code table (Outdoor unit) " on page 03-4	
Detective actuator	Wired remote controller (2-wire)	When the number of the connected indoor unit exceeds the limitation.	
	Indoor unit main PCB		
Forecast of cause	Wrong wiring of indoor unit or remote controller		
	Number of indoor unit or remote controller in remote controller group		
	Indoor unit main PCB failure		

Check point 1. Wire installation

- Wrong number of connected indoor unit
-> If there is an abnormal condition, correct it by refer to the installation manual or the "DESIGN & TECHNICAL MANUAL".



Check point 2. Check indoor unit main PCB

- Check if main PCB is damaged.
- Change main PCB and check the error after setting remote controller address.



End

2-8. E: 32.X. Indoor unit main PCB error (Indoor unit)

Indicator	Indoor unit	Operation indicator	3 time flash
		Timer indicator	2 time flash
		Economy indicator	Continuous flash
		Error code	E: 32
	outdoor unit	Refer to " Error code table (Outdoor unit) " on page 03-4	
Detective actuator	Indoor unit	main PCB	When power is on and there is some below case. 1. When model information of EEPROM is incorrect. 2. When the access to EEPROM failed.
Forecast of cause			External cause
			Defective connection of electric components
			Main PCB failure

Check point 1. Reset power supply and operate

Does error indication show again?

→ If no, go to "[Check point 1-2](#)".



Check point 2. Check Indoor unit electric components

- Check all connectors. (loose connector or incorrect wiring)
- Check any shortage or corrosion on PCB.



Check point 3. Replace main PCB

Change main PCB.



End

Check point 1-2. Check external cause such as noise

- Check if the ground connection is proper.
- Check if there is any equipment that causes harmonic wave near the power cable (Neon light bulb or any electronic equipment which causes harmonic wave).



End

NOTE: EEPROM

EEPROM (Electrically Erasable and Programmable Read Only Memory) is a non-volatile memory which keeps memorized information even if the power is turned off. It can change the contents electronically. To change the contents, it uses higher voltage than normal, and it cannot change a partial contents. (Rewriting shall be done upon erasing the all contents.) There is a limit in a number of rewriting.

2-9. E: 35.X. MANUAL AUTO button error (Indoor unit)

Indicator	Indoor unit	Operation indicator	3 time flash
		Timer indicator	5 time flash
		Economy indicator	Continuous flash
		Error code	E: 35
	outdoor unit	Refer to " Error code table (Outdoor unit) " on page 03-4	
Detective actuator	Indoor unit controller PCB	When the MANUAL AUTO button becomes on for consecutive 60 or more seconds.	
	Indicator PCB		
	Manual auto switch		
Forecast of cause	MANUAL AUTO button failure		
	Controller PCB and indicator PCB failure		

Check point 1. Check the MANUAL AUTO button

- Check if MANUAL AUTO button is kept pressed.
- Check On/Off switching operation by using a meter.

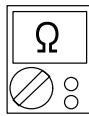

If MANUAL AUTO button is disabled (on/off switching), replace it.



Check point 2. Replace main PCB and indicator PCB

If Check Point 1 does not improve the symptom, change main PCB and indicator PCB.



End

2-10. E: 3A.X. Indoor unit communication circuit error (Indoor unit)

Indicator	Indoor unit	Operation indicator	3 time flash
		Timer indicator	10 time flash
		Economy indicator	Continuous flash
		Error code	E: 3A
	outdoor unit	Refer to " Error code table (Outdoor unit) " on page 03-4	
Detective actuator	Wired remote controller (2-wire)	When the indoor unit detects the configuration of remote controller group abnormal or the indoor unit detects lack of the primary remote controller	
	Indoor unit controller PCB circuit		
Forecast of cause			Terminal connection abnormal
			Wired remote controller failure
			Indoor unit main PCB defective

Check point 1. Check the connection of terminal

- After turning off the power supply, check and correct as follows:
Indoor unit: Check the connection of the terminal between the remote controller and indoor unit, or between indoor units and check if there is a disconnection or short of the cable.



Check point 2. Check the indoor unit main PCB

- Check terminal voltage of CN300 of main PCB (Power supply for remote)
If terminal voltage is DC 12 V, remote controller failure (Control PCB is OK).
If terminal voltage is DC 0 V, main PCB failure (Remote controller is OK).





NOTE: In case of re-installation is done due to removed connector or incorrect wiring, turn on the power again.



End

Tip

Depending on the connected remote controller type, following setting is required:

Connected remote controller	DIP switch	Jumper (JM9)
2-wire type	 2WIRE/3WIRE Factory setting: 2WIRE	 JM9 Disconnected
3-wire type	 2WIRE/3WIRE Factory setting: 3WIRE	 JM9 Connected (Factory setting)

- 2-wire type remote main PCB
If the communication PCB is not connected and JM9 is disconnected, 3A error is displayed.
If the communication PCB is connected and JM9 is connected, the 2-wire remote controller does not work.
If the DIP switch is 3-wire side, the 2-wire type remote controller does not work.
- 3-wire type remote main PCB
If the DIP switch is 2-wire side, the 3-wire type remote controller does not work.

2-11. E: 41.X. Room temperature sensor error (Indoor unit)

Indicator	Indoor unit	Operation indicator	4 time flash
		Timer indicator	1 time flash
		Economy indicator	Continuous flash
		Error code	E: 41
	outdoor unit	Refer to " Error code table (Outdoor unit) " on page 03-4	
Detective actuator	Indoor unit main PCB	Room temperature thermistor is open or short is detected always.	
	Room temperature thermistor		
Forecast of cause		Connector failure	
		Thermistor failure	
		Main PCB failure	

Check point 1. Check connection of connector

- Check if connector is loose or removed.
- Check erroneous connection.
- Check if thermistor cable is open

-> Reset power when reinstalling due to removed connector or incorrect wiring.



Check point 2. Remove connector and check thermistor resistance value

- For the room thermistor resistance value, refer to "[Thermistor resistance values](#)" on page 03-56.
- If thermistor is either open or shorted, replace it and reset the power.

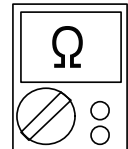

Check point 3. Check voltage of main PCB

Make sure circuit diagram of each indoor unit and check terminal voltage at thermistor (DC 5.0 V).

NOTE: For details of thermistor connector, refer to "[Wiring diagrams](#)" in Chapter 2. TECHNICAL DATA AND PARTS LIST on page 02-21.

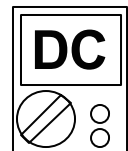

If the voltage does not appear, replace main PCB.



End

2-12. E: 42.X. Indoor unit heat exchanger sensor error (Indoor unit)

Indicator	Indoor unit	Operation indicator	4 time flash
		Timer indicator	2 time flash
		Economy indicator	Continuous flash
		Error code	E: 42
	outdoor unit	Refer to " Error code table (Outdoor unit) " on page 03-4	
Detective actuator	Indoor unit main PCB	When heat exchanger temperature thermistor open or short circuit is detected.	
	Heat exchanger temperature thermistor		
Forecast of cause		Connector connection failure	
		Thermistor failure	
		Main PCB failure	

Check point 1. Check connection of connector

- Check if connector is loose or removed.
- Check erroneous connection.
- Check if thermistor cable is open

-> Reset power when reinstalling due to removed connector or incorrect wiring.



Check point 2. Remove connector and check thermistor resistance value

- For the heat exchanger thermistor resistance value, refer to "[Thermistor resistance values](#)" on page 03-56.
- If thermistor is either open or shorted, replace it and reset the power.

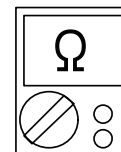

Check point 3. Check voltage of main PCB

Make sure circuit diagram of each indoor unit and check terminal voltage at thermistor (DC 5.0 V).

NOTE: For details of thermistor connector, refer to "[Wiring diagrams](#)" in Chapter 2. TECHNICAL DATA AND PARTS LIST on page 02-21.



If the voltage does not appear, replace main PCB.



End

2-13. E: 51.X. Indoor unit fan motor error (Indoor unit)

Indicator	Indoor unit	Operation indicator	5 time flash
		Timer indicator	1 time flash
		Economy indicator	Continuous flash
		Error code	E: 51
	outdoor unit	Refer to " Error code table (Outdoor unit) " on page 03-4	
Detective actuator	Indoor unit	main PCB	When the actual rotation number of the indoor unit fan motor is below 1/3 of the target rotation number continuously for more than 56 seconds.
		Fan motor	
Forecast of cause			Fan rotation failure
			Fan motor winding open
			Motor protection by surrounding temperature rise
			Control PCB failure
			Indoor unit fan motor failure
		Wrong fan motor connected	

Check point 1. Check rotation of fan

Rotate the fan by hand when operation is off. (Check if fan is caught, dropped off or locked motor)
→ If fan or bearing is abnormal, replace it.



Check point 2. Check for missing connectors and broken wires

- Reinsert the connector.
- Check the wiring continuity between the transformer and fan motor and between the CN650 and controller PCB.

→ Replace the wire with connector or the wire.



Check point 3. Check the resistance value between pins of CN650

- Check with the fan motor disconnected from the controller PCB and with the power off.
- Is the resistance value between pin3 and 4 of CN650 of 5.7 kΩ ±5% and a resistance value between pin1 and 2 of 2.0 kΩ ±5%?

→ If it is not the specified resistance value, replace the controller PCB.



Check point 4. 24V AC transformer check

Turn on the power and measure the voltage with a tester. 24V AC is OK.
→ If it is not 24V, replace the transformer.



Check point 5. Replace fan motor

If Check Point 1 to 4 do not improve the symptom, replace fan motor.



End

2-14. E: 62.X. Outdoor unit main PCB error (Outdoor unit)

Indicator	Indoor unit	Operation indicator	6 time flash
		Timer indicator	2 time flash
		Economy indicator	Continuous flash
		Error code	E: 62
	outdoor unit	Refer to " Error code table (Outdoor unit) " on page 03-4	
Detective actuator	Outdoor unit	Main PCB	Access to EEPROM failed due to some cause after outdoor unit started.
Forecast of cause			External cause (Noise, temporary open, voltage drop)
			Main PCB failure

Check point 1. Reset power supply and operate

Does error indication show again?

If no, go to "[Check point 1-2](#)".



Check point 2. Replace main PCB

Change main PCB.



End

Check point 1-2. Check external cause

- Check if temporary voltage drop was not generated.
- Check if momentary open was not generated.
- Check if ground is connection correctly or there are no related cables near the power line.



End

2-15. E: 63.X. Inverter error (Outdoor unit)

Indicator	Indoor unit	Operation indicator	6 time flash
		Timer indicator	3 time flash
		Economy indicator	Continuous flash
		Error code	E: 63
	outdoor unit	Refer to " Error code table (Outdoor unit) " on page 03-4	
Detective actuator	Outdoor unit	Inverter PCB	Error information received from inverter PCB
Forecast of cause			External cause
			Power supply to inverter PCB wiring disconnection or open
			Inverter PCB failure

Check point 1. Turn the power on again?

Error displayed again?

If no, go to "[Check point 1-2](#)".



Check point 2. Check the wiring (power supply to inverter PCB)

- Connector and wiring connection state check
- Cable open check



Check point 3. Replace inverter PCB

Replace inverter PCB



End

Check point 1-2. Check external cause

- Check if temporary voltage drop was not generated.
- Check if momentary open was not generated.
- Check if ground is connection correctly or there are no related cables near the power line.



End

2-16. E: 65.X. IPM error (Outdoor unit)

Indicator	Indoor unit	Operation indicator	6 time flash
		Timer indicator	5 time flash
		Economy indicator	Continuous flash
		Error code	E: 65
	outdoor unit	Refer to " Error code table (Outdoor unit) " on page 03-4	
Detective actuator	Outdoor unit	Main PCB	<ol style="list-style-type: none"> When more than normal operating current to IPM in main PCB flows, the compressor stops. After the compressor restarts, if the same operation is repeated within 40 seconds, the compressor stops again. If 1. and 2. repeats 5 times, the compressor stops permanently.
		Compressor	
Forecast of cause		<ul style="list-style-type: none"> Defective connection of electric components Outdoor fan operation failure Outdoor heat exchanger clogged Compressor failure Main PCB failure 	

Check point 1. Check connections of outdoor unit electrical components

- Check if the terminal connection is loose.
- Check if connector is removed.
- Check erroneous connection.
- Check if cable is open.

→ Upon correcting the removed connector or mis-wiring, reset the power.



Check point 2. Check outdoor fan and heat exchanger

- Is there anything obstructing the air distribution circuit?
- Is there any clogging of outdoor heat exchanger?
- Is the fan rotating by hand when operation is off?

→ If the fan motor is locked, replace it.



Check point 3. Check outdoor fan

Check outdoor fan motor. (Refer to "[E: 97.X. Outdoor unit fan motor error \(Outdoor unit\)](#)" on page 03-34.)

→ If the fan motor is failure, replace it.



Check point 4. Check compressor

Check compressor. (Refer to inverter compressor in "[Service parts information](#)".)



Check point 5. Replace main PCB

If Check point 1 to 4 do not improve the symptom, change main PCB.



End

2-17. E: 71.X. Discharge thermistor error (Outdoor unit)

Indicator	Indoor unit	Operation indicator	7 time flash
		Timer indicator	1 time flash
		Economy indicator	Continuous flash
		Error code	E: 71
	outdoor unit	Refer to " Error code table (Outdoor unit) " on page 03-4	
Detective actuator	Outdoor unit main PCB	When discharge pipe temperature thermistor open or short circuit is detected at power on or while running the compressor	
	Discharge pipe temperature thermistor		
Forecast of cause			Connector failure
			Thermistor failure
			Main PCB failure

Check point 1. Check connection of connector

- Check if connector is loose or removed.
- Check erroneous connection.
- Check if thermistor cable is open

→ Reset power when reinstalling due to removed connector or incorrect wiring.



Check point 2. Remove connector and check thermistor resistance value

- For the discharge temperature thermistor resistance value, refer to "[Thermistor resistance values](#)" on page 03-56.
- If thermistor is either open or shorted, replace it and reset the power.

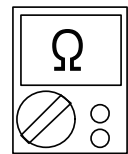

Check point 3. Check voltage of main PCB

Make sure circuit diagram of outdoor unit and check terminal voltage at thermistor (DC 5.0 V).

NOTE: For details of thermistor connector, refer to "[Wiring diagrams](#)" in Chapter 2. TECHNICAL DATA AND PARTS LIST on page 02-21.

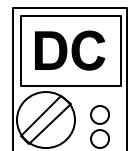

If the voltage does not appear, replace main PCB.



End

2-18. E: 72.X. Compressor thermistor error (Outdoor unit)

Indicator	Indoor unit	Operation indicator	7 time flash
		Timer indicator	2 time flash
		Economy indicator	Continuous flash
		Error code	E: 72
	outdoor unit	Refer to " Error code table (Outdoor unit) " on page 03-4	
Detective actuator	Outdoor unit main PCB	When compressor temperature thermistor open or short circuit is detected at power on or while running the compressor	
	Compressor temperature thermistor		
Forecast of cause			Connector failure
			Thermistor failure
			Main PCB failure

Check point 1. Check connection of connector

- Check if connector is loose or removed.
- Check erroneous connection.
- Check if thermistor cable is open

→ Reset power when reinstalling due to removed connector or incorrect wiring.



Check point 2. Remove connector and check thermistor resistance value

- For the compressor thermistor resistance value, refer to "[Thermistor resistance values](#)" on page 03-56.
- If thermistor is either open or shorted, replace it and reset the power.

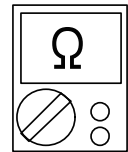

Check point 3. Check voltage of main PCB

Make sure circuit diagram of outdoor unit and check terminal voltage at thermistor (DC 5.0 V).

NOTE: For details of thermistor connector, refer to "[Wiring diagrams](#)" in Chapter 2. TECHNICAL DATA AND PARTS LIST on page 02-21.

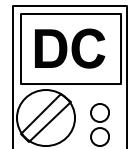

If the voltage does not appear, replace main PCB.



End

2-19. E: 73.X. Heat exchanger (Middle/Outlet) temperature thermistor error (Outdoor unit)

Indicator	Indoor unit	Operation indicator	7 time flash
		Timer indicator	3 time flash
		Economy indicator	Continuous flash
		Error code	E: 73
	outdoor unit	Refer to " Error code table (Outdoor unit) " on page 03-4	
Detective actuator	Heat exchanger liquid temperature thermistor	• Heat exchanger liquid temperature thermistor short or open detected	
	Heat exchanger middle temperature thermistor	• Heat exchanger middle temperature thermistor short or open detected	
Forecast of cause			Connector failure
			Thermistor failure
			Main PCB failure

Check Point 1 : Check the connector connection and cable open

- Connector connection state check
- Cable open check



Check Point 2 : Check the thermistor

- For the outdoor unit heat exchanger thermistor resistance value, refer to "[Thermistor resistance values](#)" on page 03-56.
- If thermistor is either open or shorted, replace it and reset the power.



Check point 3. Check voltage of main PCB

Make sure circuit diagram of outdoor unit and check terminal voltage at thermistor (DC 5.0 V).

NOTE: For details of thermistor connector, refer to "[Wiring diagrams](#)" in Chapter 2. TECHNICAL DATA AND PARTS LIST on page 02-21.



If the voltage does not appear, replace main PCB.



End

2-20. E: 74.X. Outdoor temperature thermistor error (Outdoor unit)

Indicator	Indoor unit	Operation indicator	7 time flash
		Timer indicator	4 time flash
		Economy indicator	Continuous flash
		Error code	E: 74
	outdoor unit	Refer to " Error code table (Outdoor unit) " on page 03-4	
Detective actuator	Outdoor unit main PCB	When outdoor temperature thermistor open or short circuit is detected at power on or while running the compressor	
	Outdoor temperature thermistor		
Forecast of cause		Connector failure	
		Thermistor failure	
		Main PCB failure	

Check point 1. Check connection of connector

- Check if connector is loose or removed.
- Check erroneous connection.
- Check if thermistor cable is open

-> Reset power when reinstalling due to removed connector or incorrect wiring.



Check point 2. Remove connector and check thermistor resistance value

- For the outdoor temperature thermistor resistance value, refer to "[Thermistor resistance values](#)" on page 03-56.
- If thermistor is either open or shorted, replace it and reset the power.

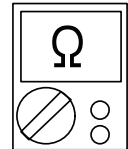

Check point 3. Check voltage of main PCB

Make sure circuit diagram of outdoor unit and check terminal voltage at thermistor (DC 5.0 V).

NOTE: For details of thermistor connector, refer to "[Wiring diagrams](#)" in Chapter 2. TECHNICAL DATA AND PARTS LIST on page 02-21.



If the voltage does not appear, replace main PCB.



End

2-21. E: 77.X. Heat sink thermistor error (Outdoor unit)

Indicator	Indoor unit	Operation indicator	7 time flash
		Timer indicator	7 time flash
		Economy indicator	Continuous flash
		Error code	E: 77
	outdoor unit	Refer to " Error code table (Outdoor unit) " on page 03-4	
Detective actuator	Heat sink temperature thermistor	Heat sink temperature thermistor short or open detected	
Forecast of cause		Connector failure	
		Thermistor failure	
		Inverter PCB failure	

Check point 1. Check connection of connector

- Check if connector is loose or removed.
- Check erroneous connection.
- Check if thermistor cable is open

-> Reset power when reinstalling due to removed connector or incorrect wiring.



Check point 2. Remove connector and check thermistor resistance value

- For the Heat sink thermistor resistance value, refer to "[Thermistor resistance values](#)" on page 03-56.
- If thermistor is either open or shorted, replace it and reset the power.

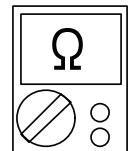

Check point 3. Check voltage of inverter PCB

Make sure circuit diagram of outdoor unit and check terminal voltage at thermistor (DC 5.0 V).

NOTE: For details of thermistor connector, refer to "[Wiring diagrams](#)" in Chapter 2. TECHNICAL DATA AND PARTS LIST on page 02-21.

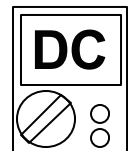

If the voltage does not appear, replace inverter PCB.



End

2-22. E: 84.X. Current sensor error (Outdoor unit)

Indicator	Indoor unit	Operation indicator	8 time flash
		Timer indicator	4 time flash
		Economy indicator	Continuous flash
		Error code	E: 84
	outdoor unit	Refer to " Error code table (Outdoor unit) " on page 03-4	
Detective actuator	Outdoor unit	main PCB	When input current sensor has detected 0 A, while inverter compressor is operating at higher than 60 rps, after 1 minute upon starting the compressor. (Except during the defrost operation)
Forecast of cause			Defective connection of electric components
			External cause
			Main PCB failure

Check point 1. Reset power supply and operate

Does error indication show again?

If no, go to "[Check point 1-2](#)".



Check point 2. Check connections of outdoor unit electrical components

- Check if the terminal connection is loose.
- Check if connector is removed.
- Check erroneous connection.
- Check if cable is open.

Upon correcting the removed connector or miswiring, reset the power.



Check point 3. Replace main PCB

If Check point 1, 2 do not improve the symptom, change main PCB.



End

Check point 1-2. Check external cause at Indoor and Outdoor (Voltage drop or Noise)

- Instant drop: Check if there is a large load electric apparatus in the same circuit.
- Momentary power failure: Check if there is a defective contact or leak current in the power supply circuit.
- Noise: Check if there is any equipment causing harmonic wave near electric line. (Neon bulb or electric equipment that may cause harmonic wave)
Check the complete insulation of grounding.



End

2-23. E: 86.X. High pressure switch error (Outdoor unit)

Indicator	Indoor unit	Operation indicator	8 time flash
		Timer indicator	6 time flash
		Economy indicator	Continuous flash
		Error code	E: 86
	outdoor unit	Refer to " Error code table (Outdoor unit) " on page 03-4	
Detective actuator	Outdoor unit main PCB	When pressure switch open is detected in 10 seconds after the power is turned on.	
	High pressure switch		
Forecast of cause	High pressure switch connector disconnection or open		
	High pressure switch characteristics failure		
	Main PCB failure		

Check point 1. Check the high pressure switch connection state

- Check connector and wiring connection state.
- Check if cable is open

-> Reset power when reinstalling due to removed connector or incorrect wiring.



Check point 2. Check the high pressure switch characteristics

- Check switch characteristics.
For the characteristics of the high pressure switch, refer to below.



Check point 3. Replace main PCB

Change main PCB and check operation again.



End

- Type of contact

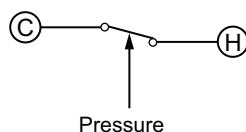

- Characteristics of pressure switch

Pressure switch 1	
Contact: Short → Open	4.2 ± 0.1 MPa
Contact: Open → Short	3.2 ± 0.15 MPa

P770

2-24. E: 94.X. Trip detection (Outdoor unit)

Indicator	Indoor unit	Operation indicator	9 time flash
		Timer indicator	4 time flash
		Economy indicator	Continuous flash
		Error code	E: 94
	outdoor unit		Refer to " Error code table (Outdoor unit) " on page 03-4
Detective actuator	Outdoor unit	Main PCB	Protection stop by over-current generation after inverter compressor start processing completed generated consecutively 5 times. NOTE: The number of generations is reset when the compressor starts up.
		Compressor	
Forecast of cause			Outdoor unit fan operation defective, foreign matter on heat-exchanger, excessive rise of ambient temperature
			Main PCB failure
			Inverter compressor failure (lock, winding short)

Check point 1. Check the outdoor unit fan operation, heat-exchanger, ambient temperature

- No obstructions in air passages?
- Heat exchange fins clogged
- Outdoor unit fan motor check
- Ambient temperature not raised by the effect of other heat sources?
- Discharged air not sucked in?



Check point 2. Replace main PCB

If Check point 1 do not improve the symptom, change main PCB.



Check point 3. Replace compressor

If Check point 2 do not improve the symptom, change compressor.



End

2-25. E: 95.X. Compressor motor control error (Outdoor unit)

Indicator	Indoor unit	Operation indicator	9 time flash
		Timer indicator	5 time flash
		Economy indicator	Continuous flash
		Error code	E: 95
	outdoor unit		Refer to " Error code table (Outdoor unit) " on page 03-4
Detective actuator	Outdoor unit	Main PCB	<ol style="list-style-type: none"> When running the compressor, if the detected rotor location is out of phase with actual rotor location more than 105°, the compressor stops. After the compressor restarts, if the same operation is repeated within 40 seconds, the compressor stops again. If 1. and 2. repeats 5 times, the compressor stops permanently.
		Compressor	
Forecast of cause			Defective connection of electric components
			Main PCB failure
			Compressor failure

Check point 1. Check Noise from Compressor

Turn on Power and check operation noise.
→ If an abnormal noise show, replace compressor.



Check point 2. Check connection of around the compressor components

For compressor terminal, main PCB

- Check if connector is removed.
- Check erroneous connection.
- Check if cable is open. (Refer to inverter compressor in "[Service parts information](#)" on page 03-50.)

→ Upon correcting the removed connector or mis-wiring, reset the power.



Check point 3. Replace main PCB

If Check point 1, 2 do not improve the symptom, change main PCB.



Check point 4. Replace compressor

If Check point 3 do not improve the symptom, change compressor.



End

2-26. E: 97.X. Outdoor unit fan motor error (Outdoor unit)

Indicator	Indoor unit	Operation indicator	9 time flash
		Timer indicator	7 time flash
		Economy indicator	Continuous flash
		Error code	E: 97
	outdoor unit		Refer to " Error code table (Outdoor unit) " on page 03-4
Detective actuator	Outdoor unit	Main PCB	<ol style="list-style-type: none"> When outdoor fan rotation speed is less than 100 rpm in 20 seconds after fan motor starts, fan motor stops. After fan motor restarts, if the same operation within 60 seconds is repeated 3 times in a row, compressor and fan motor stops. If 1. and 2. repeats 5 times in a row, compressor and fan motor stops permanently.
		Fan motor	
Forecast of cause			Fan rotation failure
			Motor protection by surrounding temperature rise
			Main PCB failure
			Outdoor unit fan motor

Check point 1. Check rotation of fan

Rotate the fan by hand when operation is off. (Check if fan is caught, dropped off or locked motor)
→ If fan or bearing is abnormal, replace it.



Check point 2. Check ambient temperature around motor

Check excessively high temperature around the motor. (If there is any surrounding equipment that causes heat)
→ Upon the temperature coming down, restart operation.



Check point 3. Check outdoor unit fan motor

Check outdoor unit fan motor. (Refer to outdoor unit fan motor in "[Service parts information](#)" on page 03-50.)
→ If outdoor unit fan motor is abnormal, replace outdoor unit fan motor and main PCB.



Check point 4. Check output voltage of main PCB

Check outdoor unit circuit diagram and the voltage. (Measure at main PCB side connector)

NOTE: For details of wiring diagram, refer to "[Wiring diagrams](#)" in Chapter 2. TECHNICAL DATA AND PARTS LIST on page 02-21.



Read wire	DC voltage
Red—Black	260 V to 400 V
White—Black	15 ± 1.5 V

→ If the voltage is not correct, replace Main PCB.



End

2-27. E: 99.X. 4-way valve error (Outdoor unit)

Indicator	Indoor unit	Operation indicator	9 time flash
		Timer indicator	9 time flash
		Economy indicator	Continuous flash
		Error code	E: 99
	outdoor unit	Refer to " Error code table (Outdoor unit) " on page 03-4	
Detective actuator	Indoor unit	main PCB	When the indoor heat exchanger temperature is compared with the room temperature, and either following condition is detected continuously two times, the compressor stops. Indoor heat exchanger temp. - Room temp. > 18 °F (10 °C) (Cooling or Dry operation) Indoor heat exchanger temp. - Room temp. < -18 °F (-10 °C) (Heating operation) If the same operation is repeated 5 times, the compressor stops permanently.
	Heat exchanger temperature thermistor		
	Room temperature thermistor		
	4-way valve		
Forecast of cause			Connector connection failure
			Thermistor failure
			Coil failure
			4-way valve failure
			Main PCB failure

Check point 1. Check connection of connector

- Check if connector is removed.
- Check erroneous connection.
- Check if thermistor cable is open.

→ Upon correcting the removed connector or mis-wiring, reset the power.



Check point 2. Check each thermistor

- Isn't it fallen off the holder?
- Is there a cable pinched?

Check characteristics of room thermistor and indoor unit heat exchanger thermistor.

For the thermistor resistance value, refer to "[Thermistor resistance values](#)" on page 03-56.

→ If defective, replace the thermistor.



Check point 3. Check the solenoid coil and 4-way valve

NOTE: Refer solenoid coil and 4-way valve in "[Service parts information](#)" on page 03-50.

- **Solenoid coil**
Remove P60 from PCB and check the resistance value of coil. Resistance value is 2,085 Ω (at 68 °F [20 °C]).
→ If it is open or abnormal resistance value, replace solenoid coil.
- **4-way valve**
Check each piping temperature, and the location of the valve by the temperature difference.
If the value location is not proper, replace 4-way valve.



Check point 4. Replace main PCB

If Check Point 1 to 3 do not improve the symptom, replace main PCB.



End

2-28. E: 9A.X. Coil (Expansion valve) error

Indicator	Indoor unit	Operation indicator	9 time flash
		Timer indicator	10 time flash
		Economy indicator	Continuous flash
		Error code	E: 9A
	Outdoor unit	Refer to " Error code table (Outdoor unit) " on page 03-4	
Detective actuator	EEV coil	When the power is turned on and when the data of the automatic correction was damaged.	
	Main PCB		
Forecast of cause			EEV coil loose connection
			EE1 wires cut or pinched
			Defective EEV coil
			Main PCB (DC 12 V) output abnormal

Check point 1. Check the connection of EEV connector

Check if the connector is loose connection or not.



Check point 2. Check the EEV wire

Check if the wire of EEV has damage or not. (Slash, Braking of wire, Pinching, etc.)

→ If it is abnormal, replace EEV coil.



Check point 3. Check the EEV coil

Check if the circuit of EEV coil winding is good or not. (Refer to "[Service parts information](#)" on page 03-50.)

→ If it is abnormal, replace EEV coil.



Check point 4. Check the output of EEV on the main PCB

Check if the DC 12 V is on between the Pin No.1 of CN111 and GND Pin. (Disconnect the wire of EEV when you check the output of EEV.)

→ If it is abnormal, replace main PCB.



Check point 5. Noise, momentary open, voltage drop

- Check if temporary voltage drop was not generated.
- Check if momentary open was not generated.
- Check if ground is connection correctly or there are no related cables near the power line.



End

2-29. E: A1.X. Discharge temperature error (Outdoor unit)

Indicator	Indoor unit	Operation indicator	10 time flash
		Timer indicator	1 time flash
		Economy indicator	Continuous flash
		Error code	E: A1
	outdoor unit	Refer to " Error code table (Outdoor unit) " on page 03-4	
Detective actuator	Discharge temperature thermistor		Protection stop by discharge temperature ≥ 230 °F (110 °C) (30 model), 239 °F (115 °C) (36/48 model) during compressor operation generated 2 times within 24 hours (30 model), 40 minutes (36/48 model).
Forecast of cause			3-way valve not opened
			EEV or capillary tube defective, strainer clogged
			Outdoor unit operation failure, foreign matter on heat exchanger
			Discharge temperature thermistor failure
		Insufficient refrigerant	

Check point 1. Check if 3-way valve is open

If the 3-way valve is closed, open the 3-way valve and check operation.

NOTE: For cooling operation, check gas side of the 3-way valve.

For heating operation, check liquid side of the 3-way valve.



Check point 2. Check any of the electronic expansion valve (EEV), capillary tube, or strainer, or all

- Check if EEV open or there is a capillary tube defect.
Refer to outdoor unit Electronic Expansion Valve (EEV) or Capillary tube in "[Service parts information](#)" on page 03-50.
- Check the strainer clogging.



Check point 3. Check the outdoor unit fan and heat exchanger

- Check for foreign object at heat exchanger
- Check if fan can be rotated by hand.
- Check the motor. (Refer to outdoor unit fan motor in "[Service parts information](#)" on page 03-50.)



Check point 4. Check the discharge thermistor

The discharge temperature thermistor characteristics check. (Check by disconnecting thermistor from PCB.)

NOTE: For the characteristics of the thermistor, refer to "[Thermistor resistance values](#)" on page 03-56.



Check point 5. Check the refrigerant amount

Check the refrigerant leakage.



End

2-30. E: A3.X. Compressor temperature error (Outdoor unit)

Indicator	Indoor unit	Operation indicator	10 time flash
		Timer indicator	3 time flash
		Economy indicator	Continuous flash
		Error code	E: A3
	outdoor unit	Refer to " Error code table (Outdoor unit) " on page 03-4	
Detective actuator	Compressor temperature thermistor	Protection stop by compressor temperature ≥ 226.4 °F (115 °C) (30 model), 230 °F (110 °C) (36/48 model) during compressor operation generated 2 times within 24 hours (30 model), 40 minutes (36/48 model).	
Forecast of cause			3-way valve not opened
			EEV defective, strainer clogged
			Outdoor unit operation failure, foreign matter on heat exchanger
			Compressor temperature thermistor failure
		Insufficient refrigerant	

Check point 1. Check if 3-way valve is open

If the 3-way valve is closed, open the 3-way valve and check operation.

NOTE: For cooling operation, check gas side of the 3-way valve.

For heating operation, check liquid side of the 3-way valve.



Check point 2. Check the electronic expansion valve (EEV) and strainer

- Check if EEV open.
Refer to outdoor unit Electronic Expansion Valve (EEV) in "[Service parts information](#)" on page 03-50.
- Check the strainer clogging.



Check point 3. Check the outdoor unit fan and heat exchanger

- Check for foreign object at heat exchanger
- Check if fan can be rotated by hand.
- Check the motor. (Refer to outdoor unit fan motor in "[Service parts information](#)" on page 03-50.)



Check point 4. Check the compressor thermistor

The compressor temperature thermistor characteristics check. (Check by disconnecting thermistor from PCB.)

NOTE: For the characteristics of the thermistor, refer to "[Thermistor resistance values](#)" on page 03-56.



Check point 5. Check the refrigerant amount

Check the refrigerant leakage.



End

2-31. E: AC.X. Heat sink temperature error (Outdoor unit)

Indicator	Indoor unit	Operation indicator	10 time flash
		Timer indicator	12 time flash
		Economy indicator	Continuous flash
		Error code	E: AC
	outdoor unit	Refer to " Error code table (Outdoor unit) " on page 03-4	
Detective actuator	Outdoor unit inverter PCB	Protection stop by heat sink temperature ≥ 176 °F (80 °C) during heat sink operation generated 2 times within 24 hours.	
	Heat sink temperature thermistor		
Forecast of cause	Foreign matter on heat sink, heat sink dirty		
	Foreign matter on heat exchanger, excessive ambient temperature rise		
	Heat sink temp. thermistor defective		

Check point 1. Check the heat sink state

Heat sink foreign matter, soiling check



Check point 2. Check the foreign matter and ambient temperature of heat exchanger

- Heat exchange foreign matter check
- Ambient temperature not raised by effect of other heat sources?
- Discharged air not sucked in?



Check point 3. Check the heat sink temperature thermistor

The heat sink temperature thermistor characteristics check. (Check by disconnecting thermistor from PCB.)

NOTE: For the characteristics of the thermistor, refer to "[Thermistor resistance values](#)" on page 03-56.



Check point 4. Replace inverter PCB

Replace inverter PCB



End

3. Troubleshooting without error code

3-1. Indoor unit—No power

Forecast of cause	Power supply failure
	External cause
	Electrical components defective

Check point 1. Check installation condition

- Isn't the breaker down?
- Check loose or removed connection cable.

-> If abnormal condition is found, correct it by referring to the installation manual or the "DESIGN & TECHNICAL MANUAL".



Check point 2. Check external cause at indoor and outdoor (voltage drop or noise)

- Instant drop: Check if there is a large load electric apparatus in the same circuit.
- Momentary power failure: Check if there is a defective contact or leak current in the power supply circuit.
- Noise: Check if there is any equipment causing harmonic wave near electric line. (Neon bulb or electric equipment that may cause harmonic wave)
Check the complete insulation of grounding.



Check point 3. Check electrical components

Check the voltage of power supply.

Check if AC 187 to 253 V appears at outdoor unit terminal L1—L2.

-> If no, go to "[Check point 1](#)" and "[Check point 2](#)".



- Check fuse in filter PCB.
If fuse is open, check if the wiring between terminal and filter PCB is loose, and replace fuse.
- Check varistor in filter PCB.
If varistor is defective, there is a possibility of an abnormal power supply.
Check the correct power supply and replace varistor.
Upon checking the normal power supply, replace varistor.



End

3-2. Outdoor unit—No power

Forecast of cause	Power supply failure
	External cause
	Electrical components defective

Check point 1. Check installation condition

- Is the circuit breaker on or off?
- Check loose or removed connection cable.

→ If abnormal condition is found, correct it by referring to the installation manual or the "DESIGN & TECHNICAL MANUAL".



Check point 2. Check external cause at indoor and outdoor (voltage drop or noise)

- Instant drop: Check if there is a large load electric apparatus in the same circuit.
- Momentary power failure: Check if there is a defective contact or leak current in the power supply circuit.
- Noise: Check if there is any equipment causing harmonic wave near electric line. (Neon bulb or electric equipment that may cause harmonic wave)
Check the complete insulation of grounding.



Check point 3. Check electrical components

Check the voltage of power supply.

Check if AC 187 to 253 V appears at outdoor unit terminal L1 — L2

→ If no, go to "[Check point 1](#)" and "[Check point 2](#)".

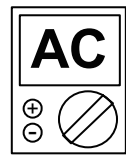

- Check fuse in main PCB.
If fuse is open, check if the wiring between terminal and main PCB is loose, and replace fuse.



Check point 4. Replace main PCB

If check point 1 to 3 do not improve the symptom, change main PCB.



End

3-3. No operation (Power is on)

Forecast of cause	Setting/ Connection failure
	External cause
	Electrical components defective

Check point 1. Check indoor and outdoor installation condition

- Indoor unit:
 - Check incorrect wiring between indoor unit and remote controller.
 - Check if there is an open cable connection.
 - Are these indoor unit, outdoor unit, and remote controller suitable model numbers to connect?
- > If there is some abnormal condition, correct it by referring to the installation manual and "DESIGN & TECHNICAL MANUAL".



Turn off the power and check correct followings.

- Is there loose or removed communication line of indoor unit and outdoor unit?



Check point 2. Check external cause at indoor and outdoor (Voltage drop or Noise)

- Instant drop: Check if there is a large load electric apparatus in the same circuit.
- Momentary power failure: Check if there is a defective contact or leak current in the power supply circuit.
- Noise: Check if there is any equipment causing harmonic wave near electric line. (Neon bulb or electric equipment that may cause harmonic wave)
Check the complete insulation of grounding.



Check point 3. Check wired remote controller and controller PCB

Check voltage at CN300 of main PCB.
(Power supply to remote controller)

- If it is DC 12 V, remote controller is failure. (The controller PCB is normal)
-> Replace remote controller.
- If it is DC 0 V, controller PCB is failure. (Check the remote controller once again)
-> Replace controller PCB.



Check point 4. Replace main PCB

If check point 1 to 3 do not improve the symptom, change main PCB.



End

3-4. No cooling/No heating

Forecast of cause	Indoor unit error
	Outdoor unit error
	Effect by surrounding environment
	Connection pipe/Connection wire failure
	Refrigeration cycle failure

Check point 1. Check Indoor unit

- Does Indoor unit fan run in the HIGH mode?
- Is air filter dirty?
- Is heat exchanger clogged?
- Check if energy save function is operated.



Check point 2. Check outdoor unit operation

- Check if outdoor unit is operating.
- Check any objects that obstruct the air flow route.
- Check if heat exchanger is clogged.
- Is the valve open?



Check point 3. Check site condition

- Is capacity of Indoor unit fitted to the room size?
- Any windows open or direct sunlight?



Check point 4. Check Indoor/ Outdoor installation condition

- Check connection pipe (specified pipe length and pipe diameter?)
- Check any loose or removed communication line.

→ If there is an abnormal condition, correct it by referring to the installation manual or the "DESIGN & TECHNICAL MANUAL".



Check point 5. Check Refrigeration cycle

- Check if strainer is clogged (Refer to the figure below).
- Measure gas pressure, and if there is a leakage, correct it.
- Check if EEV open or there is a capillary tube defect.
Refer to outdoor unit Electronic Expansion Valve (EEV) or Capillary tube in "[Service parts information](#)" on page 03-50.
- Check compressor.
Refer to compressor in "[Service parts information](#)" on page 03-50.
Refer to inverter compressor in "[Service parts information](#)" on page 03-50.

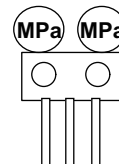

NOTE: When recharging the refrigerant, make sure to perform vacuuming, and recharge the specified amount.



End

NOTES:

- Strainer normally does not have temperature difference between inlet and outlet as shown below.

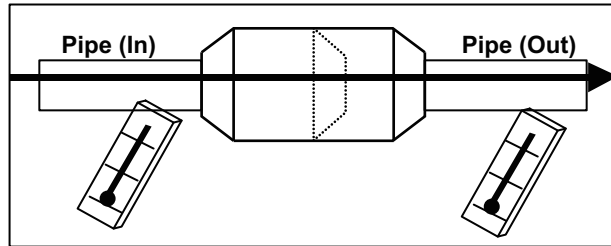

- If there is a difference like shown below, there is a possibility of inside clogged. In this case, replace the strainer.

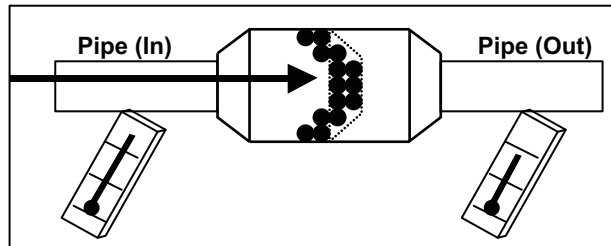

3-5. Abnormal noise

Forecast of cause	Abnormal installation (indoor unit/outdoor unit)
	Fan failure (indoor unit/outdoor unit)
	Compressor failure (outdoor)

Diagnosis method when abnormal noise is occurred

Abnormal noise is coming from Indoor unit.
(Check and correct followings)



- Is main unit installed in stable condition?
- Is the installation of air suction grille and front panel normal?



- Is fan broken or deformed?
- Is the screw of fan loose?
- Is there any object which obstruct the fan rotation?



End

Abnormal noise is coming from Outdoor unit.
(Check and correct followings)



- Is main unit installed in stable condition?
- Is fan guard installed normally?



- Is fan broken or deformed?
- Is the screw of fan loose?
- Is there any object which obstruct the fan rotation?



Check if vibration noise by loose bolt or contact noise of piping is happening.



Is compressor locked?

- Check Compressor
Refer to compressor and inverter compressor in "[Service parts information](#)" on page 03-50.



End

3-6. Water leaking

Forecast of cause	Erroneous installation
	Drain hose failure

Diagnosis method when water leak occurs

- Is main unit installed in stable condition?
- Is main unit broken or deformed at the time of transportation or maintenance?



- Is drain hose connection loose?
- Is there a trap in drain hose?
- Is drain hose clogged?



Is fan rotating?



End

Diagnosis method when water is spitting out

Is the filter clogged?



Check gas pressure and correct it if there was a gas leak.

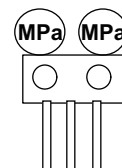

End

TROUBLESHOOTING

TROUBLESHOOTING

4. Service parts information

4-1. Compressor

Diagnosis method of compressor (If outdoor unit LED displays error, refer to troubleshooting)

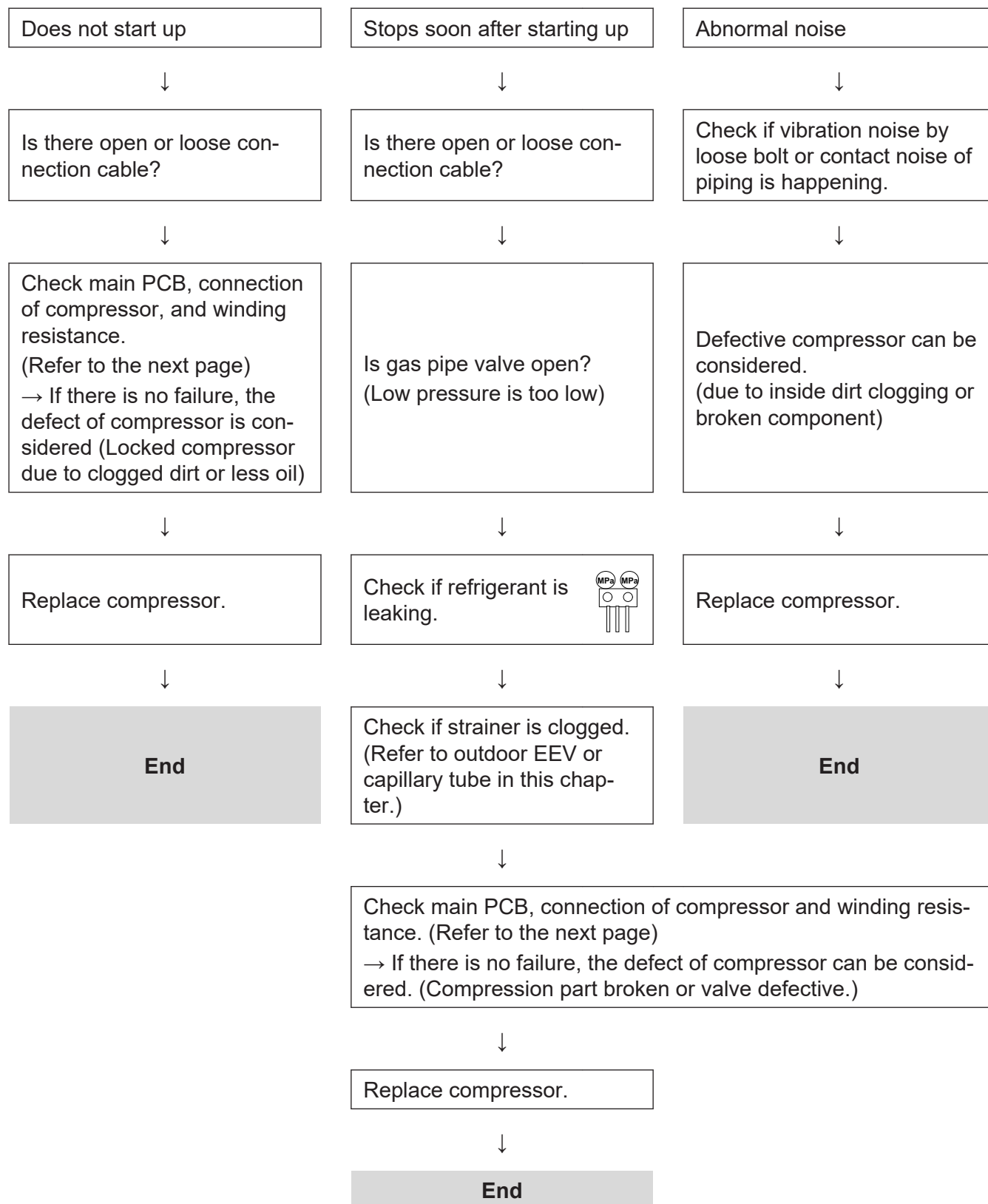

4-2. Inverter compressor

Check point 1. Check the terminal connection.

- Check the following terminal connections of the compressor. (Loosening or incorrect wiring.)

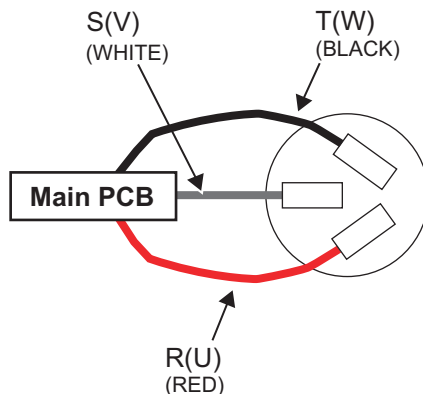

- Check terminal connection of inverter PCB (loose or incorrect wiring)

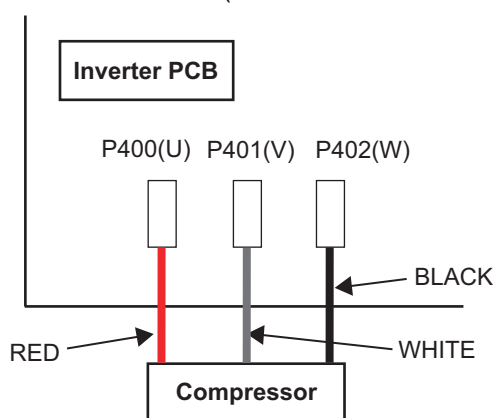

↓

Check point 2. Check the winding resistance.

Check the winding resistance of each terminal.

Resistance value

- 30 model: $0.676 \Omega \pm 8\%$ at 68°F (20°C)
- 36/48 model: 0.240Ω at 68°F (20°C)

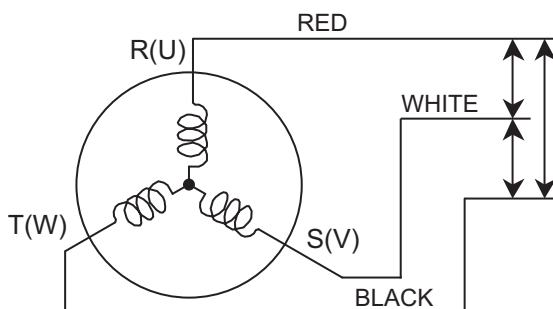
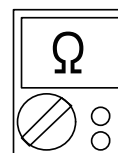

→ If the resistance value is 0Ω or infinite, replace the compressor.

↓

Check point 3. Replace the Inverter PCB.

If check point 1 to 2 do not improve the symptom, replace the Inverter PCB.

4-3. Outdoor unit Electronic Expansion Valve (EEV)

Check point 1. Check connections

Check connection of connector. (Loose connector or open cable)

NOTE: For details of wiring diagram, refer to "Wiring diagrams" in Chapter 2. TECHNICAL DATA AND PARTS LIST on page 02-21.

Check point 2. Check coil of EEV

Remove connector, check each winding resistance of coil.

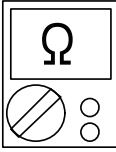
Read wire	Resistance value
1(Red) - 2(Blue)	$46 \Omega \pm 3.0 \Omega$ at 68 °F (20 °C) 
1(Red) - 3(Orange)	
1(Red) - 4(Yellow)	
1(Red) - 5(White)	

→ If Resistance value is abnormal, replace EEV.

Check point 3. Check Voltage from main PCB

Remove connector and check voltage (DC 12 V)

→ If it does not appear, replace main PCB.



Check point 4. Check noise at start up

Turn on the power and check the operation noise.

→ If an abnormal noise does not show, replace main PCB.

Check point 5. Check Opening and Closing Operation of Valve

When valve is closed, it has a temp. difference between inlet and outlet

CLOSE
 Example : Hot Gas

Pipe (In)
 Hi TEMP.

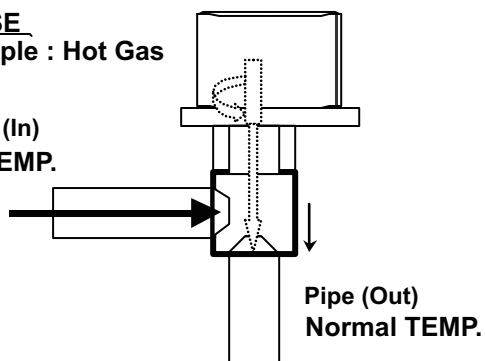

If it is open, it has no temp. difference between inlet and outlet

OPEN
 Example : Hot Gas

Pipe (In)
 Hi TEMP.

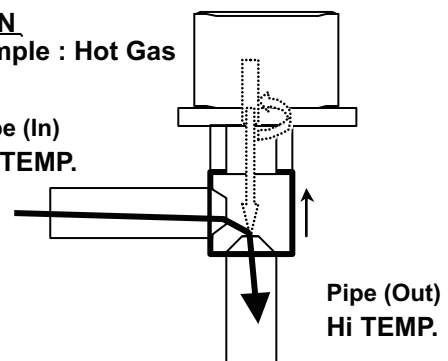

Check point 6. Check strainer

- Strainer normally does not have temperature difference between inlet and outlet as shown below.

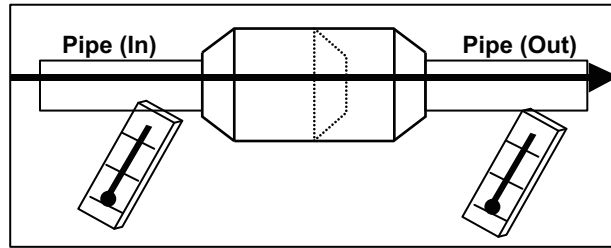

- If there is a difference like shown below, there is a possibility of inside clogged. In this case, replace the strainer.

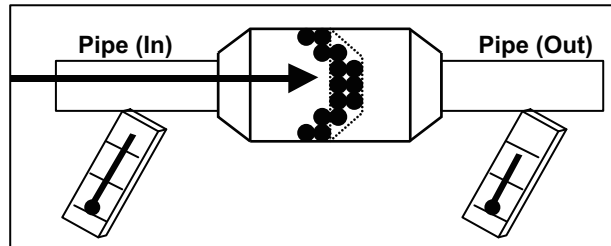

4-4. Outdoor unit fan motor

Check point 1. Check rotation of fan

Rotate the fan by hand when operation is off.
 (Check if fan is caught, dropped off or locked motor)
 → If fan or bearing is abnormal, replace it.

Check point 2. Check resistance of outdoor fan motor

Refer to below. Circuit-test "Vm" and "GND" terminal

NOTE: Vm: DC voltage, GND: Earth terminal

→ If they are short-circuited (below 300 kΩ), replace outdoor fan motor and controller PCB.

Pin number (wire color)	Terminal function (symbol)
1 (Red)	DC voltage (Vm)
2	No function
3	No function
4 (Black)	Earth terminal (GND)
5 (White)	Control voltage (Vcc)
6 (Yellow)	Speed command (Vsp)
7 (Brown)	Feed back (FG)

5. Thermistor resistance values

5-1. Indoor unit

■ Room temperature thermistor

Temperature °F (°C)	Resistance (kΩ)	Voltage (V)
14.0 (-10.0)	58.25	0.73
23.0 (-5.0)	44.03	0.93
32.0 (0.0)	33.62	1.15
41.0 (5.0)	25.92	1.39
50.0 (10.0)	20.17	1.66
59.0 (15.0)	15.84	1.94
68.0 (20.0)	12.54	2.22
77.0 (25.0)	10.00	2.50
86.0 (30.0)	8.04	2.77
95.0 (35.0)	6.51	3.03
104.0 (40.0)	5.30	3.27
113.0 (45.0)	4.35	3.48

■ Heat exchanger temperature thermistor

Temperature °F (°C)	Resistance (kΩ)	Voltage (V)
-22.0 (-30.0)	1,131.91	0.21
-13.0 (-25.0)	804.52	0.29
-4.0 (-20.0)	579.59	0.40
5.0 (-15.0)	422.89	0.53
14.0 (-10.0)	312.27	0.69
23.0 (-5.0)	233.21	0.88
32.0 (0.0)	176.03	1.10
41.0 (5.0)	134.23	1.36
50.0 (10.0)	103.34	1.63
59.0 (15.0)	80.28	1.92
68.0 (20.0)	62.91	2.21
77.0 (25.0)	49.70	2.51
86.0 (30.0)	39.57	2.79
95.0 (35.0)	31.74	3.06
104.0 (40.0)	25.64	3.30
113.0 (45.0)	20.85	3.53
122.0 (50.0)	17.06	3.73
131.0 (55.0)	14.05	3.90
140.0 (60.0)	11.64	4.05
149.0 (65.0)	9.69	4.19

5-2. Outdoor unit

■ Discharge temperature thermistor

Temperature °F (°C)	Resistance (kΩ)	Voltage (V)
-22.0 (-30.0)	1,000.13	0.06
-12.0 (-25.0)	720.28	0.09
-4.0 (-20.0)	525.51	0.12
5.0 (-15.0)	388.12	0.16
14.0 (-10.0)	289.97	0.21
23.0 (-5.0)	219.01	0.28
32.0 (0.0)	167.12	0.36
41.0 (5.0)	128.77	0.46
50.0 (10.0)	100.14	0.57
59.0 (15.0)	78.56	0.71
68.0 (20.0)	62.14	0.87
77.0 (25.0)	49.54	1.04
86.0 (30.0)	39.79	1.23
95.0 (35.0)	32.19	1.44
104.0 (40.0)	26.22	1.66
113.0 (45.0)	21.49	1.88
122.0 (50.0)	17.73	2.12
131.0 (55.0)	14.71	2.35
140.0 (60.0)	12.27	2.57
149.0 (65.0)	10.29	2.79
158.0 (70.0)	8.68	3.00
167.0 (75.0)	7.35	3.19
176.0 (80.0)	6.26	3.38
185.0 (85.0)	5.35	3.54
194.0 (90.0)	4.59	3.69
203.0 (95.0)	3.96	3.83
212.0 (100.0)	3.43	3.96
221.0 (105.0)	2.98	4.07
230.0 (110.0)	2.60	4.17
239.0 (115.0)	2.28	4.26
248.0 (120.0)	2.00	4.33

■ Compressor temperature thermistor

Temperature °F (°C)	Resistance (kΩ)	Voltage (V)
-22.0 (-30.0)	1,013.11	0.06
-12.0 (-25.0)	729.09	0.09
-4.0 (-20.0)	531.56	0.12
5.0 (-15.0)	392.31	0.16
14.0 (-10.0)	292.91	0.21
23.0 (-5.0)	221.09	0.28
32.0 (0.0)	168.60	0.36
41.0 (5.0)	129.84	0.46
50.0 (10.0)	100.91	0.57
59.0 (15.0)	79.12	0.71
68.0 (20.0)	62.55	0.86
77.0 (25.0)	49.84	1.03
86.0 (30.0)	40.01	1.23
95.0 (35.0)	32.35	1.43
104.0 (40.0)	26.34	1.65
113.0 (45.0)	21.58	1.88
122.0 (50.0)	17.79	2.11
131.0 (55.0)	14.75	2.34
140.0 (60.0)	12.30	2.57
149.0 (65.0)	10.32	2.79
158.0 (70.0)	8.70	3.00
167.0 (75.0)	7.36	3.19
176.0 (80.0)	6.27	3.37
185.0 (85.0)	5.36	3.54
194.0 (90.0)	4.60	3.69
203.0 (95.0)	3.96	3.83
212.0 (100.0)	3.43	3.96
221.0 (105.0)	2.98	4.07
230.0 (110.0)	2.60	4.17
239.0 (115.0)	2.27	4.26
248.0 (120.0)	2.00	4.33

■ Heat exchanger temperature thermistor

Temperature °F (°C)	Resistance (kΩ)	Voltage (V)
-22.0 (-30.0)	95.58	0.24
-12.0 (-25.0)	68.90	0.32
-4.0 (-20.0)	50.31	0.43
5.0 (-15.0)	37.19	0.57
14.0 (-10.0)	27.81	0.73
23.0 (-5.0)	21.02	0.92
32.0 (0.0)	16.05	1.14
41.0 (5.0)	12.38	1.39
50.0 (10.0)	9.63	1.65
59.0 (15.0)	7.56	1.93
68.0 (20.0)	5.98	2.21
77.0 (25.0)	4.77	2.49
86.0 (30.0)	3.84	2.77
95.0 (35.0)	3.11	3.02
104.0 (40.0)	2.53	3.26
113.0 (45.0)	2.08	3.48
122.0 (50.0)	1.71	3.68
131.0 (55.0)	1.42	3.85
140.0 (60.0)	1.19	4.00
149.0 (65.0)	1.00	4.13
158.0 (70.0)	0.84	4.25
167.0 (75.0)	0.71	4.35
176.0 (80.0)	0.61	4.43

■ Outdoor temperature thermistor

Temperature °F (°C)	Resistance (kΩ)	Voltage (V)
-22.0 (-30.0)	224.33	0.73
-12.0 (-25.0)	159.71	0.97
-4.0 (-20.0)	115.24	1.25
5.0 (-15.0)	84.21	1.56
14.0 (-10.0)	62.28	1.90
23.0 (-5.0)	46.58	2.26
32.0 (0.0)	35.21	2.61
41.0 (5.0)	26.88	2.94
50.0 (10.0)	20.72	3.25
59.0 (15.0)	16.12	3.52
68.0 (20.0)	12.64	3.76
77.0 (25.0)	10.00	3.97
86.0 (30.0)	7.97	4.14
95.0 (35.0)	6.40	4.28
104.0 (40.0)	5.18	4.41
113.0 (45.0)	4.21	4.51
122.0 (50.0)	3.45	4.59
131.0 (55.0)	2.85	4.65

■ Heat sink thermistor

Temperature °F (°C)	Resistance (kΩ)	Voltage (V)
-22.0 (-30.0)	94.26	0.08
-12.0 (-25.0)	67.95	0.11
-4.0 (-20.0)	49.62	0.15
5.0 (-15.0)	36.68	0.20
14.0 (-10.0)	27.42	0.26
23.0 (-5.0)	20.73	0.34
32.0 (0.0)	15.83	0.43
41.0 (5.0)	12.21	0.55
50.0 (10.0)	9.50	0.68
59.0 (15.0)	7.46	0.84
68.0 (20.0)	5.90	1.01
77.0 (25.0)	4.71	1.21
86.0 (30.0)	3.78	1.42
95.0 (35.0)	3.06	1.64
104.0 (40.0)	2.50	1.88
113.0 (45.0)	2.05	2.11
122.0 (50.0)	1.69	2.35
131.0 (55.0)	1.40	2.58
140.0 (60.0)	1.17	2.81
149.0 (65.0)	0.99	3.02
158.0 (70.0)	0.83	3.22
167.0 (75.0)	0.70	3.41
176.0 (80.0)	0.60	3.58

4. CONTROL AND FUNCTIONS

CONTENTS

4. CONTROL AND FUNCTIONS

1. Rotation number control of compressor.....	04-1
1-1. Cooling operation	04-1
1-2. Heating operation	04-1
1-3. Dry operation	04-2
1-4. Rotation number of compressor at normal start-up	04-3
1-5. Rotation number of compressor limitation by outdoor temperature	04-5
2. Auto changeover operation.....	04-7
3. Fan control.....	04-9
3-1. Indoor fan control.....	04-9
3-2. Outdoor fan control.....	04-11
4. Timer operation control	04-13
4-1. Wireless remote control	04-13
4-2. Wired remote control	04-15
5. Defrost operation control	04-18
5-1. Defrost operation in heating operation stopped	04-19
6. Various control	04-20
6-1. Auto restart.....	04-20
6-2. MIN. HEAT operation	04-20
6-3. ECONOMY operation	04-20
6-4. Compressor preheating	04-21
6-5. Electronic expansion valve control	04-21
6-6. Prevention to restart for 3 minutes (3 minutes st)	04-21
6-7. 4-way valve control.....	04-21
6-8. Peak cut operation	04-22
7. Various protections.....	04-23
7-1. Discharge gas temperature over-rise prevention control	04-23
7-2. Anti-freezing control (cooling and dry mode)	04-23
7-3. Current release control	04-24
7-4. Compressor temperature protection	04-24
7-5. High pressure protection	04-25
7-6. Low outdoor temperature protection.....	04-25
7-7. High temperature and high pressure release control.....	04-26

1. Rotation number control of compressor

1-1. Cooling operation

A sensor (room temperature thermistor) built in the indoor unit body will usually perceive difference or variation between a set temperature and present room temperature, and controls the operation rotation number of the compressor.

- If the room temperature is 7 °F (3.5 °C) higher than a set temperature, the operation rotation number of compressor will attain to maximum performance.
- If the room temperature is 1 °F (0.5 °C) lower than a set temperature, the compressor will be stopped.
- When the room temperature is within the range of +7 °F (+3.5 °C) to -1 °F (0.5 °C) of the setting temperature, the rotation number of compressor is controlled within the range shown in the table below. However, the maximum rotation number is limited in the range shown in the figure below based on the indoor fan mode and the outdoor temperature.

1-2. Heating operation

A sensor (room temperature thermistor) built in indoor unit body will usually perceive difference or variation between setting temperature and present room temperature, and controls operation rotation number of compressor.

- If the room temperature is 9 °F (4.5 °C) lower than a set temperature, the operation rotation number of compressor will attain to maximum performance.
- If the room temperature is 1 °F (0.5 °C) higher than a set temperature, the compressor will be stopped.
- When the room temperature is within the range of +1 °F (+0.5 °C) to -9 °F (-4.5 °C) of the setting temperature, the rotation number of compressor is controlled within the range shown below.
- **Rotation number range of compressor**

Unit: rps

Model name	Minimum frequency	Maximum frequency
AMUG30LMAS	10	120
AMUG36LMAS AMUG48LMAS	15	120

1-3. Dry operation

The rotation number of compressor shall change according to the temperature, set temperature, and room temperature variation which the room temperature sensor of the indoor unit has detected as shown in the table below.

Zone is defined by set temperature and room temperature.

- **Compressor control based on room temperature**

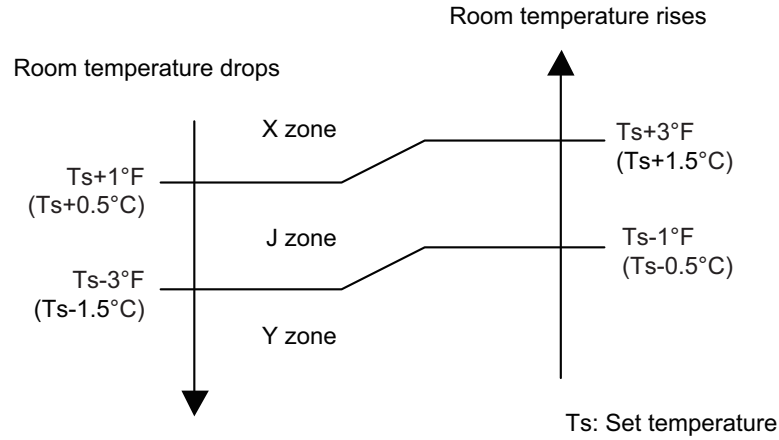

1-4. Rotation number of compressor at normal start-up

■ Model: AOUH30LUAH1

Rotation number of compressor soon after starting is controlled as below.

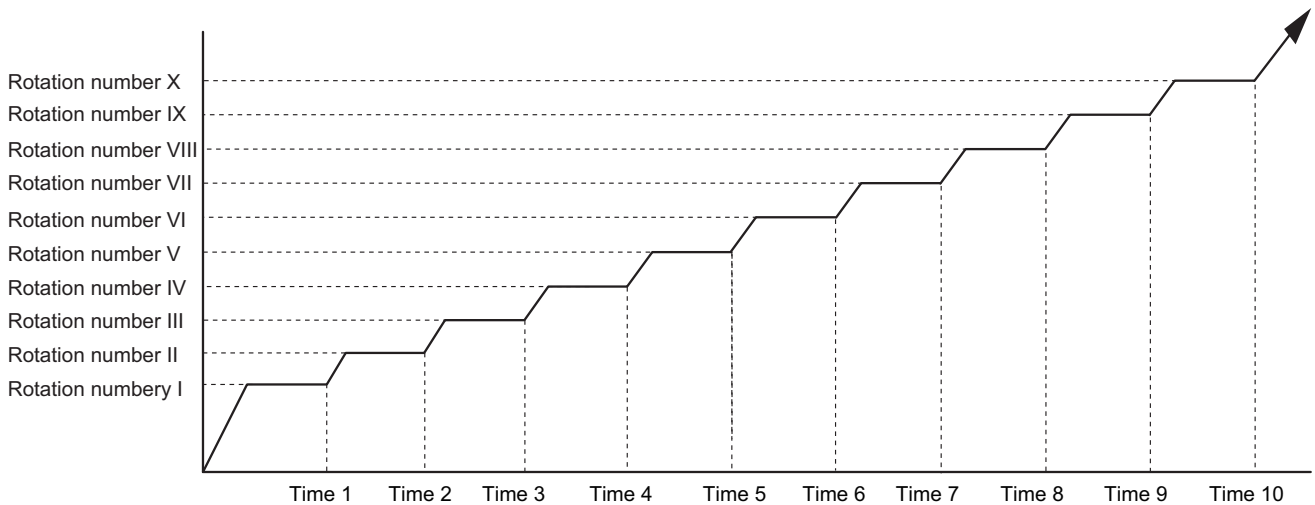

• Normal operation

Rotation number (rps)	I	II	III	IV	V	VI	VII	VIII	IX	X
	41	46	51	57	60	72	81	91	100	110
Time (sec)	1	2	3	4	5	6	7	8	9	10
	60	120	180	300	420	480	540	600	660	720

• Special operation

Rotation number (rps)	I	II	III	IV	V	VI	VII	VIII	IX	X
	41	46	51	57	60	72	81	91	100	110
Time (sec)	1	2	3	4	5	6	7	8	9	10
	120	185	245	365	665	725	785	845	905	1,060

NOTES:

- Normal operation:
 - Cooling and dry mode
 - Below 3 hours from the compressor stop and the compressor thermistor $\geq 59\text{ }^{\circ}\text{F}$ ($15\text{ }^{\circ}\text{C}$)
 - After defrost operation
 - Other than when the compressor starts for the first time since the breaker turns on
- Special operation:
 - Other than the normal operation condition
 - When the compressor starts for the first time since the breaker turns on

Models: AOUH36LMAH1 and AOUH48LMAH1

Rotation number of compressor soon after starting is controlled as below.

- Normal operation

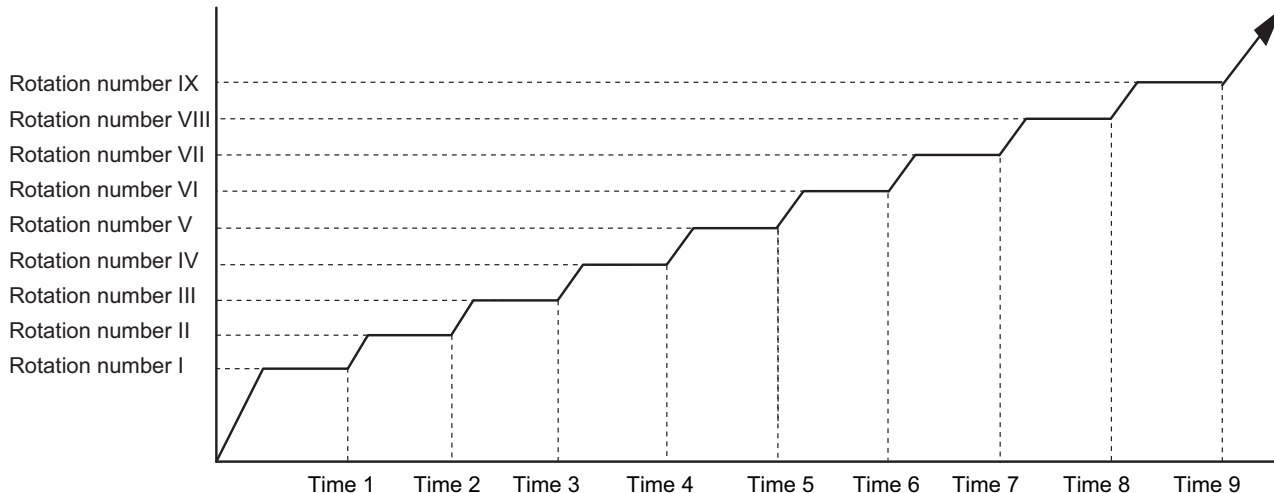

Rotation number (rps)	I	II	III	IV	V	VI	VII	VIII	IX
	25	35	45	60	70	80	90	100	110
Time (sec)	1	2	3	4	5	6	7	7	8
	90	180	300	480	600	660	720	780	840

- Special operation

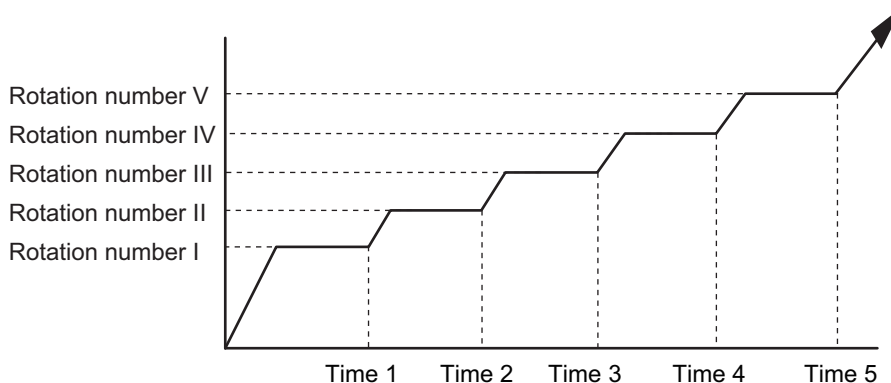

Rotation number (rps)	I	II	III	IV	V
	25	35	45	60	70
Time (sec)	1	2	3	4	5
	120	240	720	1,260	1,380

NOTES:

- Normal operation:
 - Cooling and dry mode
 - Below 3 hours from the compressor stop and the compressor thermistor $\geq 59\text{ }^{\circ}\text{F}$ ($15\text{ }^{\circ}\text{C}$)
 - After defrost operation
 - Other than when the compressor starts for the first time since the breaker turns on
- Special operation:
 - Other than the normal operation condition
 - When the compressor starts for the first time since the breaker turns on

1-5. Rotation number of compressor limitation by outdoor temperature

The minimum rotation number of compressor is limited by outdoor temperature as below.

- **Cooling/Dry mode**

122.0 °F (50 °C)	K zone
114.8 °F (46 °C)	J zone
107.6 °F (42 °C)	I zone
100.4 °F (38 °C)	H zone
87.8 °F (31 °C)	G zone
55.4 °F (13 °C)	F zone
44.6 °F (7 °C)	E zone
35.6 °F (2 °C)	D zone
23.0 °F (-5 °C)	C zone
14.0 °F (-10 °C)	B zone
	A zone

Model name	Outdoor temperature zone	Limitation of compressor frequency
AOUH30LUAH1	A zone	35 rps
	B zone	28 rps
	C zone	28 rps
	D zone	22 rps
	E zone	22 rps
	F zone	10 rps
	G zone	14 rps
	H zone	18 rps
	I zone	18 rps
	J zone	18 rps
	K zone	22 rps
AOUH36LMAH1 AOUH48LMAH1	A zone	27 rps
	B zone	27 rps
	C zone	25 rps
	D zone	25 rps
	E zone	18 rps
	F zone	15 rps
	G zone	23 rps
	H zone	27 rps
	I zone	32 rps
	J zone	36 rps
	K zone	40 rps

- Heating mode

68.0 °F (20 °C)	F zone
44.6 °F (7 °C)	E zone
35.6 °F (2 °C)	D zone
14.0 °F (-10 °C)	C zone
5.0 °F (-15 °C)	B zone
	A zone

Model name	Outdoor temperature zone	Limitation of compressor frequency
AOUH30LUAH1	A zone	36 rps
	B zone	28 rps
	C zone	22 rps
	D zone	22 rps
	E zone	14 rps
	F zone	20 rps
AOUH36LMAH1 AOUH48LMAH1	A zone	40 rps
	B zone	30 rps
	C zone	26 rps
	D zone	18 rps
	E zone	15 rps
	F zone	18 rps

2. Auto changeover operation

When the air conditioner is set to AUTO mode by remote controller, operation starts in the optimum mode from among heating, cooling, dry and monitoring modes. During operation, the optimum mode is automatically switched in accordance with temperature changes. The temperature can be set between 64.4 °F (18 °C) and 86.0 °F (30 °C) in 1.0 °F (0.5 °C) steps.

- When operation starts, indoor fan and outdoor fan are operated for around 1 minute. Room temperature and outdoor temperature are sensed, and the operation mode is selected in accordance with the table below.

Room temperature	Operation mode
$Tr > Ts + 3.6^{\circ}\text{F}$ (2°C)	Cooling
$Ts + 3.6^{\circ}\text{F}$ (2°C) $\geq Tr \geq Ts - 3.6^{\circ}\text{F}$ (2°C)	Middle zone
$Tr < Ts - 3.6^{\circ}\text{F}$ (2°C)	Heating

Tr: Room temperature

Ts: Setting temperature

NOTE: When the operation mode is middle zone, indoor unit operation mode is selected as below.

- Same operation mode is selected as outdoor unit.
If outdoor unit is operating in cooling and heating mode, indoor unit will be operated by the same operation mode.
- Selected by outdoor temperature.
If outdoor unit is operating in other than cooling and heating mode, indoor unit will be operated according to the outdoor temperature as below.

Outdoor temp.	Operation mode
77.0°F (25°C) or more	Cooling
Less than 77.0°F (25°C)	Heating

- When the compressor was stopped for 6 consecutive minutes by temperature control function after the cooling or heating mode was selected as above, operation is switched to monitoring mode and the operation mode selection is done again.
- When the middle zone is selected on the predetermining of the operation mode, the operation mode before the changing to the monitoring mode is selected.

Operation flow chart

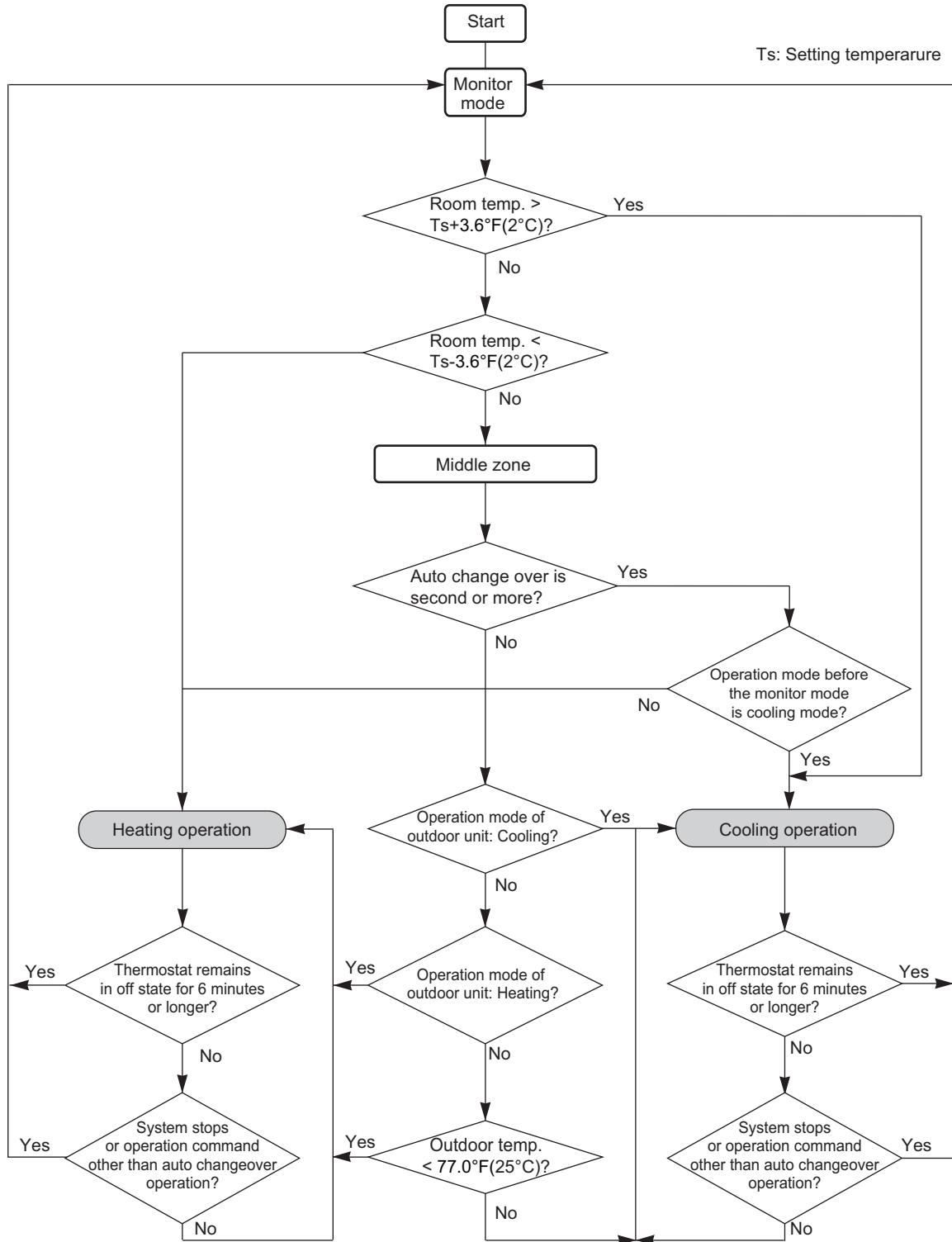

CONTROL AND FUNCTIONS

CONTROL AND FUNCTIONS

3. Fan control

Tr: Room temperature

Ts: Setting temperature

3-1. Indoor fan control

■ Fan speed

Indoor fan speed is defined as below.

Operation mode	Fan mode	Speed (rpm)		
		AMUG30LMAS	AMUG36LMAS	AMUG48LMAS
Heating	HIGH	870	1,200	1,640
	MED	730	740	1,020
	LOW	590	590	820
	QUIET	310	490	590
	S-LOW	300	480	480
Cooling/Fan	HIGH	870	1,200	1,640
	MED	730	740	1,020
	LOW	590	590	820
	QUIET	310	490	590
	Soft quiet	300*1	480*1	480*1
	S-LOW	300*2	480*2	480*2
Dry		310	490	590

*1: Fan mode only

*2: Cooling mode only

■ Fan operation

Airflow can be switched in 5 steps such as AUTO, QUIET, LOW, MED, HIGH while indoor unit fan only runs.

When fan mode is set at AUTO, it operates on MED fan speed.

■ Cooling operation

Switch the airflow AUTO, and indoor fan motor will run according to room temperature, as below.

On the other hand, if switched in HIGH—QUIET, indoor motor will run at a constant airflow of COOL operation modes QUIET, LOW, MED, HIGH as shown in “Fan speed” above.

Airflow change over (Cooling: Auto)

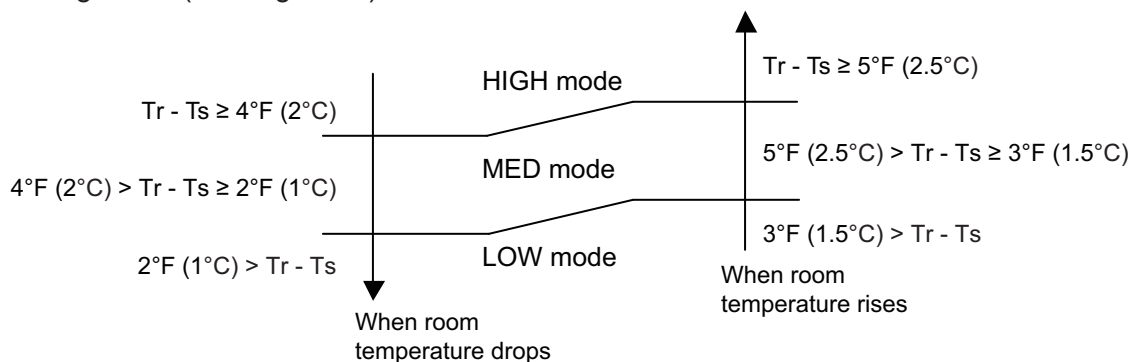

■ Dry operation

During dry operation, fan speed setting can not be changed as shown in “Fan speed” above.

■ Heating operation

Switch the airflow AUTO, and the indoor fan motor will run according to a room temperature, as below.

On the other hand, if switched in HIGH—QUIET, the indoor motor will run at a constant airflow of HEAT operation modes QUIET, LOW, MED, HIGH as shown in “Fan speed” above.

Airflow change over (Heating: Auto)

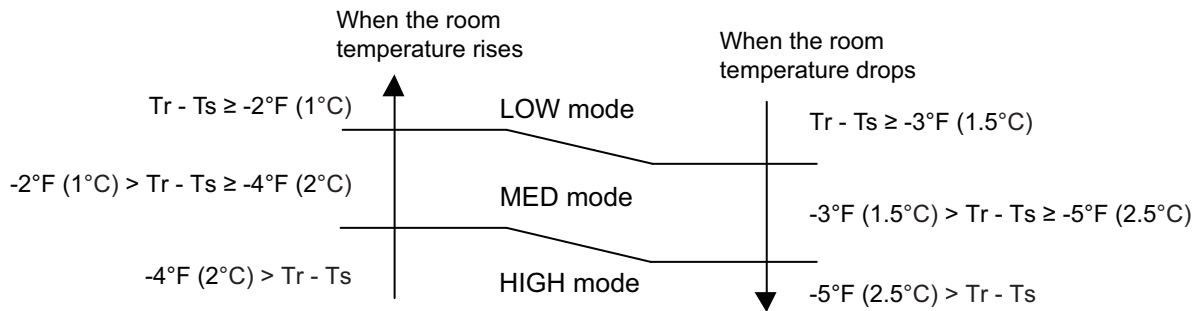

■ Cool air prevention control (heating mode)

The maximum value of the indoor fan speed is set as shown below, based on the detected temperature by the indoor heat exchanger sensor on heating mode.

• Normal operation

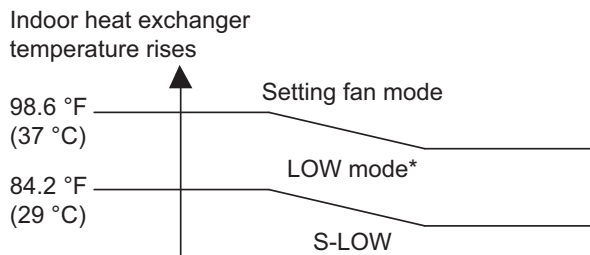

*: On the Quiet mode, the Quiet mode is kept.

13 minutes later:

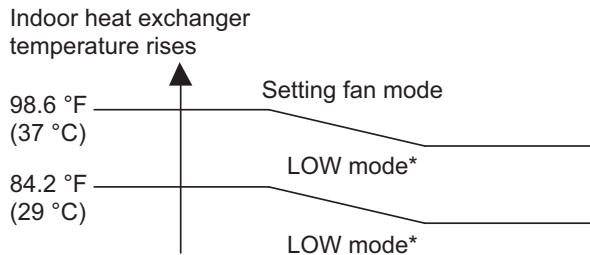

*: On the Quiet mode, the Quiet mode is kept.

■ Moisture return prevention control (cooling and dry mode)

Switch the airflow AUTO at cooling mode, and the indoor fan motor will run as shown below.

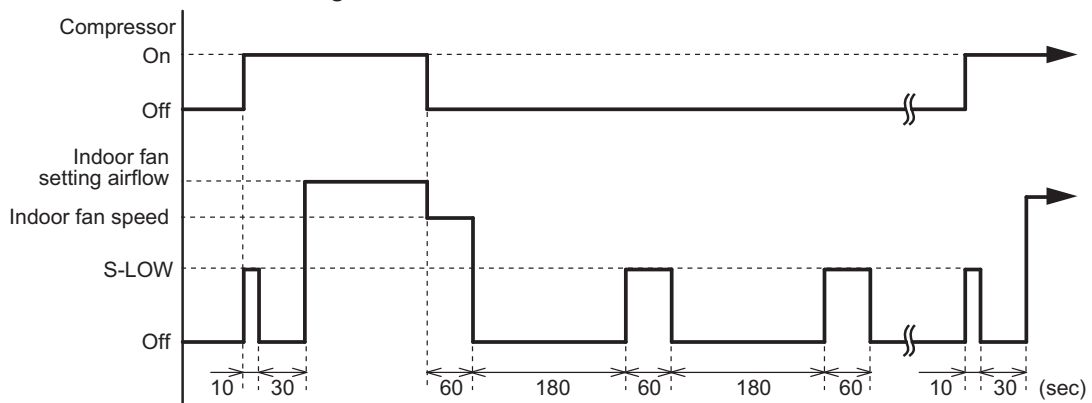

3-2. Outdoor fan control

■ Outdoor fan motor

This outdoor unit has a DC fan motor. (Control method is different between AC and DC motors.)

■ Fan speed

● Model: AOUH30LUAH1

Fan speed is defined by outdoor temperature and compressor frequency.

Unit: rpm

Fan step	Cooling or dry	Heating
13	890	—
12	890	—
11	890	—
10	890	910
9	830	830
8	710	710
7	640	640
6	580	580
5	520	520
4	460	460
3	390	390
2	340	340
1	290	290
S-HIGH	—	910

- When the compressor frequency increases, the outdoor fan speed also changes to the higher speed.
- When the compressor frequency decreases, the outdoor fan speed also changes to the lower speed.

NOTE: After defrost control on the heating mode, the fan speed is kept higher regardless of the compressor frequency.

Fan speed after defrost control: 910 rpm

● Models: AOUH36LMAH1 and AOUH48LMAH1

Fan speed is defined by outdoor temperature and compressor frequency.

Unit: rpm

(First row: upper fan, second row: lower fan)

Fan step	Cooling or dry	Heating
13	780	—
	700	
12	780	—
	700	
11	780	—
	700	
10	660	800
	660	700
9	670	660
	590	660
8	540	670
	540	590
7	450	540
	410	540
6	340	450
	340	410
5	270	340
	250	340
4	390	270
	0	250
3	340	270
	0	250
2	290	270
	0	250
1	250	270
	0	250
S-HIGH	—	800
		700

NOTE: After defrost control on the heating mode, the fan speed is kept higher regardless of the compressor frequency.

Fan speed after defrost control: 800 rpm

4. Timer operation control

4-1. Wireless remote control

On/Off timer	Program timer	Sleep timer	Weekly timer
○	○	○	—

■ On/Off timer

- Off timer: When the clock reaches the set timer, the air conditioner will be turned off.

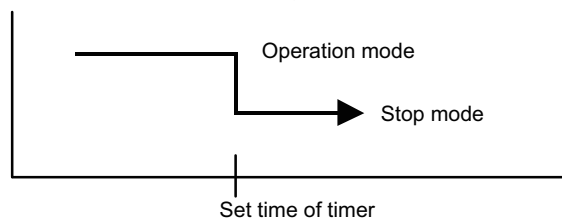

- On timer: When the clock reaches the set timer, the air conditioner will be turned on.

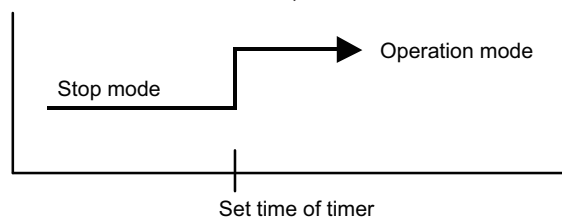

■ Program timer

- The program timer allows the off timer and the on timer to be used in combination one time.

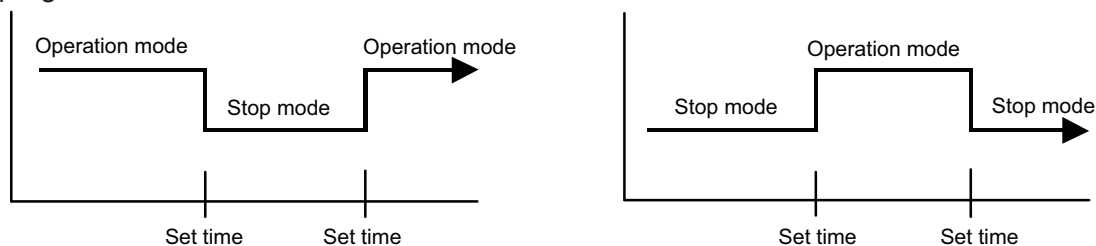

- Operation will start from the timer setting (either off timer and on timer) whichever is closest to the clock current timer setting. The order of operations is indicated by the allow in the remote controller screen.
- Sleep timer operation cannot be combined with on timer operation.

■ Sleep timer

If the sleep timer is set, the room temperature is monitored and the operation is stopped automatically. If the operation mode or the set temperature is change after the sleep timer is set, the operation is continued according to the changed setting of the sleep timer from that time on.

- In the cooling operation mode

When the sleep timer is set, the setting temperature is increased 1.8°F (1°C). It increases the setting temperature another 1.8°F (1°C) after 1 hour. After that, the setting temperature is not changed and the operation is stopped at the setting time.

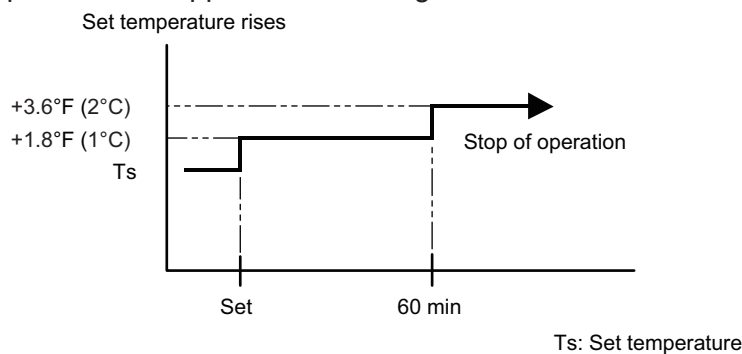

- In the heating operation mode

When the sleep timer is set, the setting temperature is decreased 1.8°F (1°C). It decreases the setting temperature another 1.8°F (1°C) every 30 minutes. Upon lowering 7.2°F (4°C), the setting temperature is not changed and the operation is stopped at the setting time.

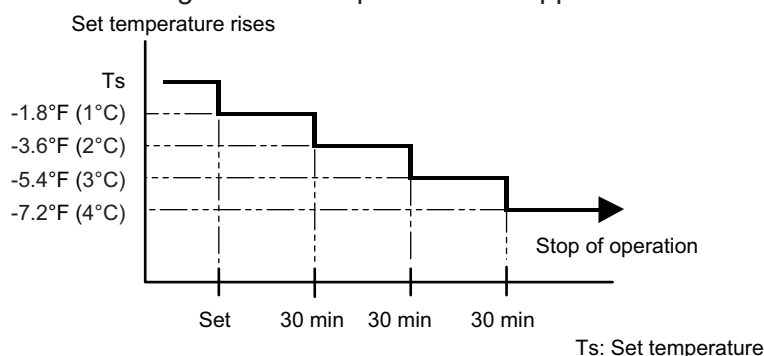

4-2. Wired remote control

On/Off timer	Program timer	Sleep timer	Weekly timer	Temperature set back timer
○	○	○	○	○

■ On/Off timer

- Off timer: When the clock reaches the set timer, the air conditioner will be turned off.

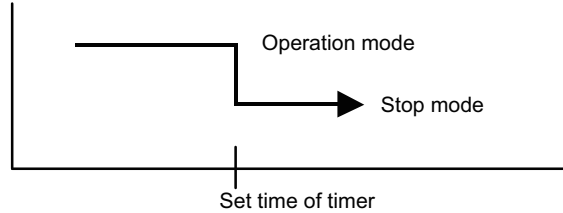

- On timer: When the clock reaches the set timer, the air conditioner will be turned on.

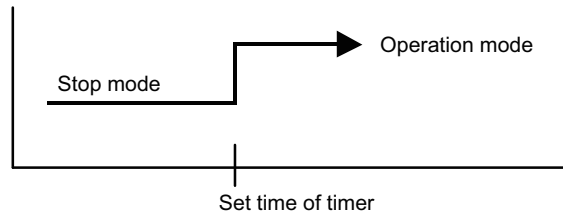

■ Program timer

- The program timer allows the off timer and the on timer to be used in combination one time.

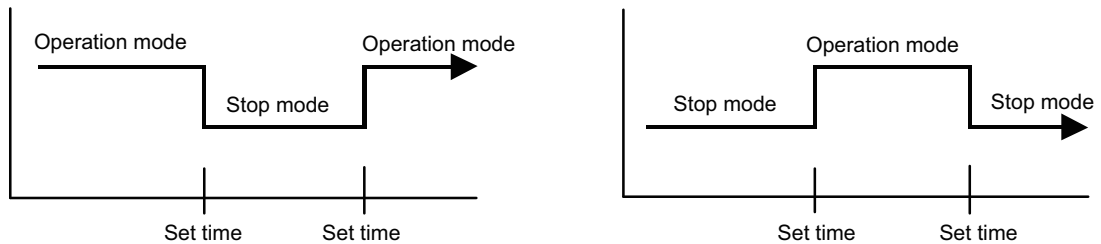

- Operation will start from the timer setting (either off timer and on timer) whichever is closest to the clock current timer setting. The order of operations is indicated by the allow in the remote controller screen.
- Sleep timer operation cannot be combined with on timer operation.

■ Sleep timer

If the sleep timer is set, the room temperature is monitored and the operation is stopped automatically. If the operation mode or the set temperature is change after the sleep timer is set, the operation is continued according to the changed setting of the sleep timer from that time on.

- In the cooling operation mode

When the sleep timer is set, the setting temperature is increased 1.8°F (1°C). It increases the setting temperature another 1.8°F (1°C) after 1 hour. After that, the setting temperature is not changed and the operation is stopped at the setting time.

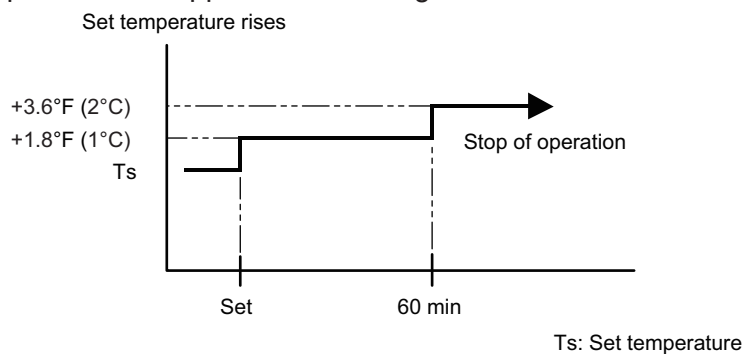

- In the heating operation mode

When the sleep timer is set, the setting temperature is decreased 1.8°F (1°C). It decreases the setting temperature another 1.8°F (1°C) every 30 minutes. Upon lowering 7.2°F (4°C), the setting temperature is not changed and the operation is stopped at the setting time.

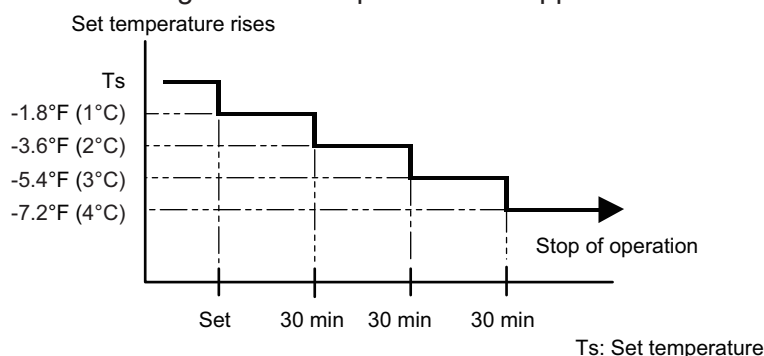

■ Weekly timer

On and off timer can be combined, and up to 4 reservations per day and 28 reservations per week. Before setting the program, set the week and time of the air conditioner at first. If the week and time are not set, the weekly timer will not operate correctly at the setting time.

■ Temperature set back timer

- The SET BACK timer only changes the set temperature for 7 days, it cannot be used to start or stop air conditioner operation.
- The SET BACK timer can be set to operate up to two times per day but only one temperature setting can be used.
- During COOLING/DRY mode, the air conditioner will operate at a minimum of 64°F (18°C) even if the SET BACK temperature is set to 63°F (17°C) or lower.

Case of SET BACK timer on the Cooling operation. (Setting temperature :72°F [22°C], SET BACK temperature :78°F [26°C])

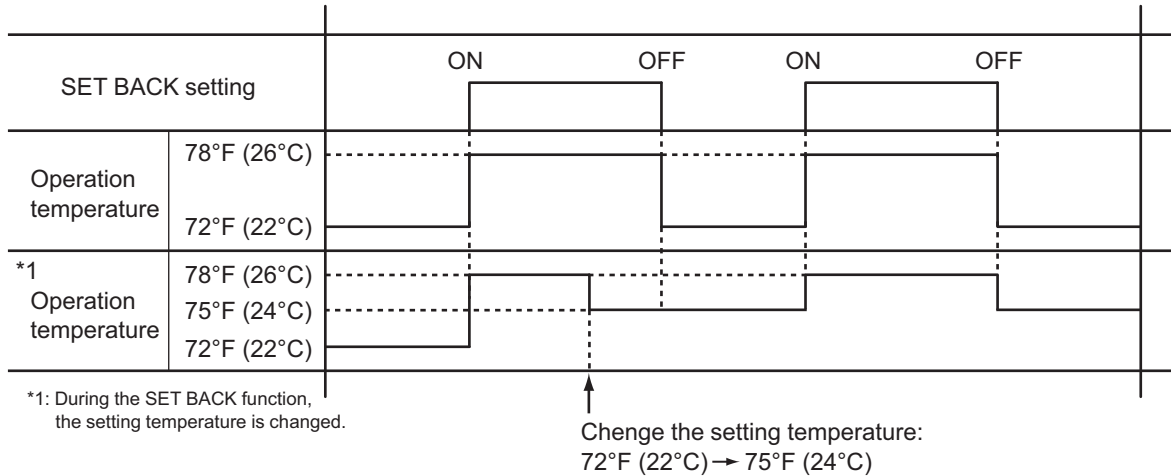

5. Defrost operation control

Tn: Outdoor unit heat exchanger temperature

Ta: Outdoor temperature

Tn10: Temperature at 10 minutes after compressor start

Tnb: Temperature before 5 minutes

• Triggering condition

The defrost operation starts when outdoor unit heat exchanger temperature sensor detects the temperature lower than the values shown below.

– 1st time defrosting after starting operation

Compressor integrating operation time	Less than 17 min.	17 to 57 min.	More than 57 min.
Condition	Does not operate	$T_n \leq 15.8 \text{ °F } (-9 \text{ °C})$ and $T_n - T_a \geq 9.0 \text{ °F } (5 \text{ °C})$	$T_n \leq 23.0 \text{ °F } (-5 \text{ °C})$

– 2nd time and after

Compressor integrating operation time	Less than 35 min.	More than 35 min.	
Condition	Does not operate	$T_n - T_{n10} < -9.0 \text{ °F } (-5 \text{ °C})$ ($T_n \leq 14.0 \text{ °F } [-10 \text{ °C}]$) $T_n - T_{nb} < -3.6 \text{ °F } (-2 \text{ °C})$ ($T_n \leq 14.0 \text{ °F } [-10 \text{ °C}]$) $T_n \leq -32.8 \text{ °F } (-36 \text{ °C})$ ($T_a \geq -22.0 \text{ °F } [-30 \text{ °C}]$) $T_n \leq 19.4 \text{ °F } (-7 \text{ °C})$ or $T_n \leq -13.0 \text{ °F } (-36 \text{ °C})$ ($T_a < -22.0 \text{ °F } [-30 \text{ °C}]$)	

– Integrating defrost (Constant monitoring)

Compressor integrating operation time	More than 240 min. (For long continuous operation)	More than 215 min. (For long continuous operation)	Less than 10 min.* (For intermittent operation)
Condition	$T_n \leq 26.6 \text{ °F } (-3 \text{ °C})$	$T_n \leq 23.0 \text{ °F } (-5 \text{ °C})$	Count of the compressor off: 40 times

*: If the compressor continuous operation time is less than 10 minutes, the number of the compressor off is counted. If any defrost operated, the compressor off count is cleared.

• Release condition

The defrost operation is released when either one of the conditions below is satisfied.

Outdoor unit heat exchanger temperature (after 1 minute or later since compressor start)	53.6 °F (12 °C) or more
Compressor operation time	15 minutes

5-1. Defrost operation in heating operation stopped

If the outdoor unit is frosted when stopping the heating operation, it stops after performing the automatic defrosting operation.

In this time, if the indoor unit operation lamp flashes slowly (6 sec on/2 sec off), the outdoor unit allow the heat exchanger to defrost, and then stop.

• Triggering condition

When all of the following conditions are satisfied in heating operation

- Compressor operation integrating time: 30 minutes or more
- Compressor continuous operation time: 10 minutes or more
- Outdoor unit heat exchanger temperature: 24.8°F (-4°C) or less

• Release condition

The defrost operation is released when either one of the conditions below is satisfied.

Outdoor unit heat exchanger temperature (after 1 minute or later since compressor start)	53.6 °F (12 °C) or more
Compressor operation time	15 minutes

6. Various control

6-1. Auto restart

When the power was interrupted by a power failure etc. during operation, the operation contents at that time are memorized and when the power is recovered, operation is automatically started with the memorized operation contents.

Operation contents memorized when the power is interrupted	
Operation mode	
Setting temperature	
Fan mode setting	
Timer mode and set time (set by wireless remote controller)	
Airflow direction setting	
ECONOMY operation	
MIN. HEAT operation	

6-2. MIN. HEAT operation

MIN. HEAT operation performs as below setting when pressing MIN. HEAT button.

Operation mode	Heating
Setting temperature	50°F (10°C)
Fan mode	AUTO
LED display	Economy
Defrost operation	Operate as normal

6-3. ECONOMY operation

The ECONOMY operation starts by pressing ECONOMY button on the remote controller.

The ECONOMY operation is almost the same operation as below settings.

Mode	Cooling/Dry	Heating
Target temperature	Setting temperature +2°F (1°C)	Setting temperature -2°F (1°C)

6-4. Compressor preheating

By preheating the compressor, warm airflow is quickly discharged when the operation is started.

- **Triggering condition 1**

- Outdoor temperature $\leq 68^{\circ}\text{F}$ (20°C)
When outdoor temperature reaches 78.8°F (26°C), compressor preheating stops.
- 30 minutes after compressor stopped

- **Triggering condition 2**

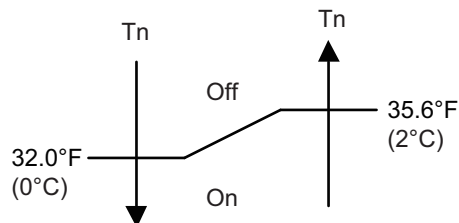

Tn: Outdoor unit heat exchanger temp.

6-5. Electronic expansion valve control

The most proper opening of the electronic expansion valve is calculated and controlled under the present operating condition based on the table below.

Operation mode	Pulse range
Cooling/dry mode	Between 47 and 480 pulses
Heating mode	Between 39 and 480 pulses

NOTE: At the time of supplying the power to the outdoor unit, the initialization of the electronic expansion valve is operated (528 pulses are input to the closing direction).

6-6. Prevention to restart for 3 minutes (3 minutes st)

When the compressor fails to start for the number of times below, it does not enter operation status for 3 minutes.

Retry number	10
Retry set number	3

When the compressor fails to start in the retry set number above, the compressor is stopped.

6-7. 4-way valve control

- If heating mode is selected at the compressor start, 4-way valve is energized for heating.
- When the air conditioner is switched between cooling and heating mode, compressor is stopped, and the 4-way valve is switched when the 3 minutes passes and the compressor is started.

6-8. Peak cut operation

The current value is limited to reduce the power consumption by external input.

Peak cut level	Level 1	Level 2	Level 3	Level 4
Peak cut for rated capacity	Forced thermostat off	50%	75%	100%

NOTES:

- During defrost operation, peak cut operation becomes invalid.
- Even during the peak cut operation, the operations of current overload, economy, and low noise are effective and the outdoor unit operates by lowest current of them.

7. Various protections

7-1. Discharge gas temperature over-rise prevention control

The discharge gas temperature sensor (discharge thermistor: outdoor unit side) detects the discharge gas temperature.

- When the discharge temperature becomes higher than the trigger condition, the compressor frequency is decreased as the table below, and it continues to decrease until the discharge temperature becomes lower than the trigger condition.
- When the discharge temperature becomes lower than the release condition, control of compressor frequency is released.
- When the discharge temperature becomes higher than the compressor protection temperature, the compressor is stopped and the indoor unit LED starts blinking.

Trigger condition	219.2 °F (104 °C)
Compressor frequency	-14 rps/120 seconds
Release condition	213.8 °F (101 °C)
Compressor protection temperature	230.0 °F (110 °C)

7-2. Anti-freezing control (cooling and dry mode)

The rotation number of compressor is decrease in cooling and dry mode when the indoor unit heat exchanger temperature sensor detects the temperature lower than the trigger condition.

When the indoor unit heat exchanger temperature reaches release condition, the anti-freezing control is stopped.

- Model: AOUH30LUAH1

Trigger condition		39.2°F (4°C)
Release condition	Outdoor temp. \geq 50°F (10°C)*1 Outdoor temp. \geq 53.6°F (12°C)*2	44.6°F (7°C)
	Outdoor temp. $<$ 50°F (10°C)*1 Outdoor temp. $<$ 53.6°F (12°C)*2	55.4°F (13°C)

- Models: AOUH36LMAH1 and AOUH48LMAH1

Trigger condition		37.4°F (3°C)
Release condition	Outdoor temp. \geq 50°F (10°C)*1 Outdoor temp. \geq 53.6°F (12°C)*2	44.6°F (7°C)
	Outdoor temp. $<$ 50°F (10°C)*1 Outdoor temp. $<$ 53.6°F (12°C)*2	

*1: During the outdoor temperature dropping

*2: During the outdoor temperature rising

7-3. Current release control

The rotation number of compressor is controlled so that the outdoor unit input current does not exceeds current limit value set according to the outdoor temperature.

The rotation number of compressor returns according to the operation mode, when the current becomes lower than the release value.

■ Model: AOUH30LUAH1

Operation mode	Outdoor temp. (Ta)	Trigger condition	Release condition
Cooling	$125.6\text{ °F (52 °C)} \leq Ta$	10.0 A	9.5 A
	$122.0\text{ °F (50 °C)} \leq Ta < 125.6\text{ °F (52 °C)}$	13.0 A	12.5 A
	$114.8\text{ °F (46 °C)} \leq Ta < 122.0\text{ °F (50 °C)}$	15.0 A	14.5 A
	$Ta < 114.8\text{ °F (46 °C)}$	17.0 A	16.5 A
Heating	$53.6\text{ °F (12 °C)} \leq Ta$	18.0 A	17.5 A
	$35.6\text{ °F (2 °C)} \leq Ta < 53.6\text{ °F (12 °C)}$	20.0 A	19.5 A
	$Ta < 35.6\text{ °F (2 °C)}$	24.0 A	23.5 A

■ Model: AOUH36LMAH1

Operation mode	Outdoor temp. (Ta)	Trigger condition	Release condition
Cooling	$125.6\text{ °F (52 °C)} \leq Ta$	12.0 A	11.5 A
	$122.0\text{ °F (50 °C)} \leq Ta < 125.6\text{ °F (52 °C)}$	15.0 A	14.5 A
	$114.8\text{ °F (46 °C)} \leq Ta < 122.0\text{ °F (50 °C)}$	17.0 A	16.5 A
	$Ta < 114.8\text{ °F (46 °C)}$	18.0 A	17.5 A
Heating	$53.6\text{ °F (12 °C)} \leq Ta$	21.0 A	20.5 A
	$35.6\text{ °F (2 °C)} \leq Ta < 53.6\text{ °F (12 °C)}$	23.0 A	22.5 A
	$Ta < 35.6\text{ °F (2 °C)}$	27.0 A	26.5 A

■ Model: AOUH48LMAH1

Operation mode	Outdoor temp. (Ta)	Trigger condition	Release condition
Cooling	$125.6\text{ °F (52 °C)} \leq Ta$	15.0 A	14.5 A
	$122.0\text{ °F (50 °C)} \leq Ta < 125.6\text{ °F (52 °C)}$	18.0 A	17.5 A
	$114.8\text{ °F (46 °C)} \leq Ta < 122.0\text{ °F (50 °C)}$	20.0 A	19.5 A
	$Ta < 114.8\text{ °F (46 °C)}$	23.0 A	22.5 A
Heating	$53.6\text{ °F (12 °C)} \leq Ta$	21.0 A	20.5 A
	$35.6\text{ °F (2 °C)} \leq Ta < 53.6\text{ °F (12 °C)}$	25.0 A	24.5 A
	$Ta < 35.6\text{ °F (2 °C)}$	30.0 A	29.5 A

7-4. Compressor temperature protection

When the compressor temperature sensor detects higher than the trigger condition below, the compressor is stopped. When the compressor temperature sensor detects the release condition, the protection is released.

Trigger condition	226.4°F (108°C)
Release condition	176.0°F (80°C) (3 minutes after compressor stop)

7-5. High pressure protection

Trigger condition	Pressure switch: Off (Open: Higher than 4.2 MPa) Compressor stop
Release condition	Pressure switch: On (Close: Lower than 3.2 MPa) (3 minutes after compressor stop) Compressor restart

7-6. Low outdoor temperature protection

When the outdoor temperature sensor detects lower than the trigger condition below, the compressor is stopped.

Operation mode	Cooling/Dry
Trigger condition	-13 °F (-25 °C)
Release condition	-4 °F (-20 °C)

7-7. High temperature and high pressure release control

The compressor is controlled as follows.

• Cooling mode

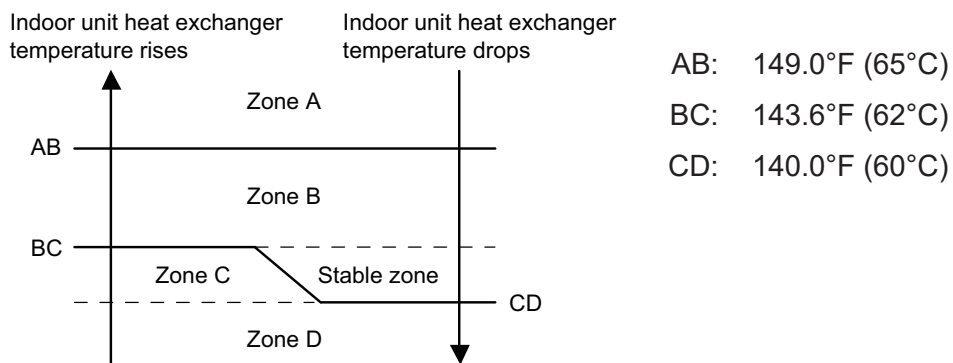

Zone	Operation	
Zone A	Compressor is stopped.	
Zone B	The compressor frequency is decreased.	-7 rps/120 sec.
Zone C	The protection is released and the operation is returned to normal mode.	
Zone D		

• Heating mode

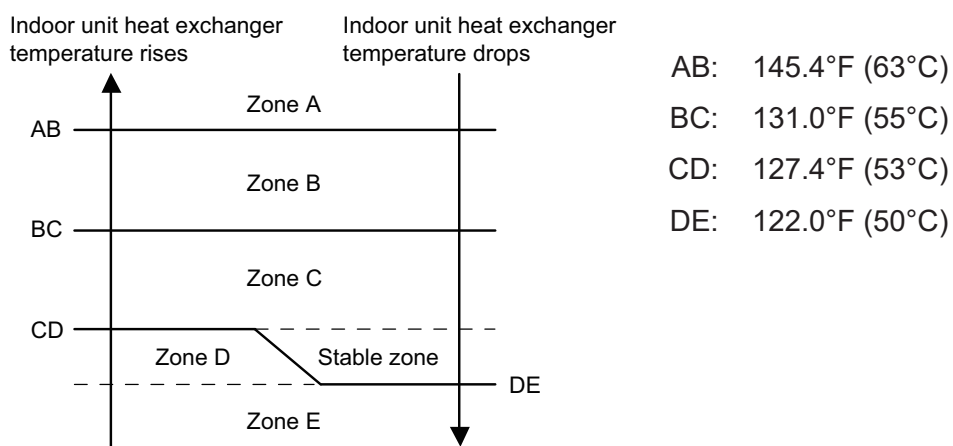

Zone	Operation	
Zone A	Compressor is stopped.	
Zone B	The compressor frequency is decreased.	-7 rps/120 sec.
Zone C		-1 rps/120 sec.
Zone D	The protection is released and the operation is returned to normal mode.	
Zone E		

5. FILED WORKING

CONTENTS

5. FILED WORKING

1. Function settings (For indoor unit).....	05-1
1-1. Function settings on indoor unit.....	05-1
1-2. Function settings by using remote controller	05-2
2. Function settings Function settings (For outdoor unit)	05-10
2-1. Control PCB and switch buttons location.....	05-10
2-2. Local setting procedure	05-12
3. External input and output.....	05-17
3-1. External input.....	05-17
3-2. External output	05-19
3-3. Combination of external input and output	05-21
3-4. Details of function	05-24

1. Function settings (For indoor unit)

To adjust the functions of this product according to the installation environment, various types of function settings are available.

NOTE: Incorrect settings can cause a product malfunction.

1-1. Function settings on indoor unit

■ Models: AMUG30LMAS, AMUG36LMAS, and AMUG48LMAS

By using some components on the PCB, you can change the function settings.

Related components on the PCB and the applicable settings

Component		Setting content
DIP switch101	1	Setting change prohibited
	2	Setting change prohibited
	3	Fan delay setting

● Component location

Components on the indoor unit main PCB used for the function settings are located as shown in the following figure.

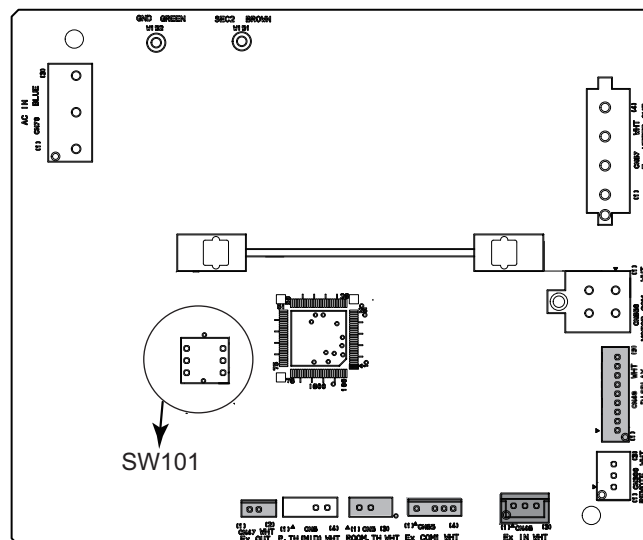

● DIP switch setting

- **Switch 1: Setting change prohibited (SW101)**
- **Switch 2: Setting change prohibited (SW101)**
- **Switch 3: Fan delay setting (SW101)**

When the indoor unit is stopped while operating in conjunction with auxiliary heater, the indoor unit fan operation will continue for 1 minute.

Switch 3	Fan delay	Factory setting
ON	Enabled	◆
OFF	Disabled	

1-2. Function settings by using remote controller

Some function settings can be changed on the remote controller. After confirming the setting procedure and the content of each function setting, select appropriate functions for your installation environment.

■ Setting procedure by using remote controller

Remote controller is not attached for this product. For details of the installing remote controller, refer to following information.

- Overview information: Operating manual of the remote controller
- Setting procedure: Installation manual of the remote controller

■ Contents of function setting

Each function setting listed in this section is adjustable in accordance with the installation environment.

NOTE: Setting will not be changed if invalid numbers or setting values are selected.

● Function setting list

	Function no.	Functions
1)	11	Filter sign
2)	30/31	Room temperature control for indoor unit sensor
3)	35/36	Room temperature control for wired remote controller sensor
4)	40	Auto restart
5)	42	Room temperature sensor switching
6)	43	Cold air prevention
7)	46	External input control
8)	48	Room temperature sensor switching (Aux.)
9)	49	Indoor unit fan control for energy saving for cooling
10)	60	Switching functions for external output terminal
11)	61	Control switching of external heaters
12)	62	Operating temperature switching of external heaters
13)	66	Outdoor temperature zone boundary temperature A
14)	67	Outdoor temperature zone boundary temperature B
15)	71	Standby time for auxiliary equipment operation
16)	72	Heat pump backup setting
17)	73	Emergency heat for external output terminal
18)	74	Fan delay time
19)	75	External heater use in defrosting
20)	92	Airflow adjustment for operation mode
21)	93	Airflow adjustment at heater only operation

1) Filter sign

Select appropriate intervals for displaying the filter sign on the indoor unit according to the estimated amount of dust in the air of the room.

If the indication is not required, select "No indication" (03).

Function number	Setting value	Setting description	Factory setting
11	00	Standard (2,500 hours)	
	01	Long interval (4,400 hours)	
	02	Short interval (1,250 hours)	
	03	No indication	◆

2) Room temperature control for indoor unit sensor

NOTE: If the remote sensor unit option is selected, perform this setting.

Depending on the installed environment, correction of the room temperature sensor may be required. Select the appropriate control setting according to the installed environment.

The temperature of the room temperature sensor is corrected as follows:

Corrected temp. = Temp. of the room temp. sensor - Correction temp. value

Example of correction:

When the temperature of the room temp. sensor is 78°F and the setting value is "03" (-2°F), the corrected temp. will be 80°F (78°F - [-2°F]).

The temperature correction values show the difference from the Standard setting "00" (manufacturer's recommended value).

Function number		Setting value	Setting description	Factory setting	
30 (For cooling)	31 (For heating)	00	Standard setting	◆	
		01	No correction 0.0 °F (0.0 °C)		
		02	-1 °F (-0.5 °C)	More cooling Less heating	
		03	-2 °F (-1.0 °C)		
		04	-3 °F (-1.5 °C)		
		05	-4 °F (-2.0 °C)		
		06	-5 °F (-2.5 °C)		
		07	-6 °F (-3.0 °C)		
		08	-7 °F (-3.5 °C)		
		09	-8 °F (-4.0 °C)		
		10	+1 °F (+0.5 °C)	Less cooling More heating	
		11	+2 °F (+1.0 °C)		
		12	+3 °F (+1.5 °C)		
		13	+4 °F (+2.0 °C)		
		14	+5 °F (+2.5 °C)		
		15	+6 °F (+3.0 °C)		
		16	+7 °F (+3.5 °C)		
17	+8 °F (+4.0 °C)				

3) Room temperature control for wired remote controller sensor

Depending on the installed environment, correction of the wire remote temperature sensor may be required. Select the appropriate control setting according to the installed environment.

To change this setting, set Function 42 to "Both" (01).

Ensure that the Thermo Sensor icon is displayed on the remote controller screen.

Function number		Setting value	Setting description	Factory setting	
35 (For cooling)	36 (For heating)	00	Standard setting	◆	
		01	No correction 0.0 °F (0.0 °C)		
		02	-1 °F (-0.5 °C)	More cooling Less heating	
		03	-2 °F (-1.0 °C)		
		04	-3 °F (-1.5 °C)		
		05	-4 °F (-2.0 °C)		
		06	-5 °F (-2.5 °C)		
		07	-6 °F (-3.0 °C)		
		08	-7 °F (-3.5 °C)		
		09	-8 °F (-4.0 °C)		
		10	+1 °F (+0.5 °C)	Less cooling More heating	
		11	+2 °F (+1.0 °C)		
		12	+3 °F (+1.5 °C)		
		13	+4 °F (+2.0 °C)		
		14	+5 °F (+2.5 °C)		
		15	+6 °F (+3.0 °C)		
		16	+7 °F (+3.5 °C)		
17	+8 °F (+4.0 °C)				

4) Auto restart

Enables or disables automatic restart after a power interruption.

Function number	Setting value	Setting description	Factory setting
40	00	Enable	◆
	01	Disable	

NOTE: Auto restart is an emergency function such as for power outage etc. Do not attempt to use this function in normal operation. Be sure to operate the unit by remote controller or external device.

5) Room temperature sensor switching

(Only for wired remote controller)

When using the wired remote controller temperature sensor, change the setting to "Both" (01).

Function number	Setting value	Setting description	Factory setting
42	00	Indoor unit	◆
	01	Both	

00: Sensor on the indoor unit is active.

01: Sensors on both indoor unit and wired remote controller are active.

NOTES:

- Remote controller sensor must be turned on by using the remote controller.
- When using the remote sensor unit, set to "00" or set to "01" and then select "indoor unit sensor" from wired remote controller.

6) Cold air prevention

This setting is to disable the cold air prevention function during heating operation. When disabled, the fan setting will always follow the setting on the remote controller. (Excluding defrost mode)

Function number	Setting value	Setting description	Factory setting
43	00	Enable	◆
	01	Disable	

7) External input control

"Operation/Stop" mode or "Forced stop" mode can be selected.

Function number	Setting value	Setting description	Factory setting
46	00	Operation/Stop mode 1	◆
	01	(Setting prohibited)	
	02	Forced stop mode	
	03	Operation/Stop mode 2	

8) Room temperature sensor switching (Aux.)

To use the temperature sensor on the wired remote controller only, change the setting to "Wired remote controller" (01).

This function will only work if the function setting 42 is set at "Both" (01).

When the setting value is set to "Both" (00), more suitable control of the room temperature is possible by setting function setting 30 and 31 too.

Function number	Setting value	Setting description	Factory setting
48	00	Both	◆
	01	Wired remote controller	

9) Indoor unit fan control for energy saving for cooling

Enables or disables the power-saving function by controlling the indoor unit fan rotation when the outdoor unit is stopped during cooling operation.

Function number	Setting value	Setting description	Factory setting
49	00	Disable	◆
	01	Enable	
	02	Remote controller	

00: When the outdoor unit is stopped, the indoor unit fan operates continuously following the setting on the remote controller.

01: When the outdoor unit is stopped, the indoor unit fan operates intermittently at a very low speed.

02: Enable or disable this function by remote controller setting.

NOTE: Set to "00" or "01" when connecting a remote controller that cannot set the Fan control for energy saving function or connecting a network converter. To confirm if the remote controller has this setting, refer to the operating manual of each remote controller.

10) Switching functions for external output terminal

Functions of the external output terminal can be switched. For details, refer to “External input and output”.

Function number	Setting value	Setting description	Factory setting
60	00	Operation status	◆
	01—04	Cooling thermostat On	
	05	Heating operation	
	06	Operation/Stop	
	07—08	Cooling thermostat On	
	09	Error status	
	10	Indoor unit fan operation status	
	11	External heater	

11) Control switching of external heaters

Sets the control method for external heater to be used.

For details, refer to “External heater output” in “Details of control output function” on page 1.

Function number	Setting value	Setting description	Factory setting
61	00	Auxiliary heater control 1	◆
	01	Auxiliary heater control 2	
	02	Heat pump prohibition control	
	03	Auxiliary heater control by outdoor temperature 1	
	04	Auxiliary heater control by outdoor temperature 2	
	05	Auxiliary heater control by outdoor temperature 3	
	06	Auxiliary heat pump control	
	07	Auxiliary heat pump control by outdoor temperature 1	
	08	Auxiliary heat pump control by outdoor temperature 2	
	09	Auxiliary heat pump control by outdoor temperature 3	

12) Operating temperature switching of external heaters

Sets the temperature conditions when the external heater is ON.

For details, refer to “External heater output” in “Details of control output function” on page 1.

Function number	Setting value	Setting description				Factory setting
		Setting value of function 61:				
		00		01 to 09		
		Heater: On	Heater: Off	Heater: On	Heater: Off	
62	00	-5.4 °F (-3 °C)	-1.8 °F (-1 °C)	-0.9 °F (-0.5 °C)	0.9 °F (0.5 °C)	◆
	01	-3.6 °F (-2 °C)	-1.8 °F (-1 °C)	-1.8 °F (-1 °C)	0.9 °F (0.5 °C)	
	02	-3.6 °F (-2 °C)	-1.8 °F (-1 °C)	-3.6 °F (-2 °C)	0.9 °F (0.5 °C)	
	03	-5.4 °F (-3 °C)	-1.8 °F (-1 °C)	-5.4 °F (-3 °C)	0.9 °F (0.5 °C)	
	04	-7.2 °F (-4 °C)	-1.8 °F (-1 °C)	-7.2 °F (-4 °C)	0.9 °F (0.5 °C)	
	05	-9.0 °F (-5 °C)	-1.8 °F (-1 °C)	-9.0 °F (-5 °C)	0.9 °F (0.5 °C)	
	06	-5.4 °F (-3 °C)	-0.9 °F (-0.5 °C)	-0.9 °F (-0.5 °C)	0 °F (0 °C)	
	07	-3.6 °F (-2 °C)	-0.9 °F (-0.5 °C)	-1.8 °F (-1 °C)	0 °F (0 °C)	
	08	-3.6 °F (-2 °C)	-0.9 °F (-0.5 °C)	-3.6 °F (-2 °C)	0 °F (0 °C)	
	09	-5.4 °F (-3 °C)	-0.9 °F (-0.5 °C)	-5.4 °F (-3 °C)	0 °F (0 °C)	
	10	-7.2 °F (-4 °C)	-0.9 °F (-0.5 °C)	-7.2 °F (-4 °C)	0 °F (0 °C)	
	11	-9.0 °F (-5 °C)	-0.9 °F (-0.5 °C)	-9.0 °F (-5 °C)	0 °F (0 °C)	
	12	-5.4 °F (-3 °C)	0 °F (0 °C)	-0.9 °F (-0.5 °C)	-0.9 °F (-0.5 °C)	
	13	-3.6 °F (-2 °C)	0 °F (0 °C)	-1.8 °F (-1 °C)	-0.9 °F (-0.5 °C)	
	14	-3.6 °F (-2 °C)	0 °F (0 °C)	-3.6 °F (-2 °C)	-0.9 °F (-0.5 °C)	
	15	-5.4 °F (-3 °C)	0 °F (0 °C)	-5.4 °F (-3 °C)	-0.9 °F (-0.5 °C)	
	16	-7.2 °F (-4 °C)	0 °F (0 °C)	-7.2 °F (-4 °C)	-0.9 °F (-0.5 °C)	
17	-9.0 °F (-5 °C)	0 °F (0 °C)	-9.0 °F (-5 °C)	-0.9 °F (-0.5 °C)		

13) Outdoor temperature zone boundary temperature A

Setting required if changing of the outdoor temperature setting for heat pump prohibition zone is required when auxiliary heater control by outdoor temperature 1 and 2 are performed on the indoor unit. For details, refer to “External heater output” in “Details of control output function” on page 1.

Function number	Setting value	Setting description	Factory setting
66	00	-4.0 °F (-20 °C)	◆
	01	-0.4 °F (-18 °C)	
	02	3.2 °F (-16 °C)	
	03	6.8 °F (-14 °C)	
	04	10.4 °F (-12 °C)	
	05	14.0 °F (-10 °C)	
	06	17.6 °F (-8 °C)	
	07	21.2 °F (-6 °C)	
08	24.8 °F (-4 °C)		

14) Outdoor temperature zone boundary temperature B

Setting required if changing of the outdoor temperature setting for heat pump only zone is required when auxiliary heater control by outdoor temperature 1 and 3 is performed on the indoor unit. For details, refer to “External heater output” in “Details of control output function” on page 1.

Function number	Setting value	Setting description	Factory setting
67	00	42.8 °F (6 °C)	◆
	01	14.0 °F (-10 °C)	
	02	17.6 °F (-8 °C)	
	03	21.2 °F (-6 °C)	
	04	24.8 °F (-4 °C)	
	05	28.4°F (-2 °C)	
	06	32.0 °F (0 °C)	
	07	35.6 °F (2 °C)	
	08	39.2 °F (4 °C)	
	09	42.8 °F (6 °C)	
	10	46.4 °F (8 °C)	
	11	50.0 °F (10 °C)	
	12	53.6 °F (12 °C)	
	13	57.2 °F (14 °C)	
	14	60.8 °F (16 °C)	
15	64.4 °F (18 °C)		

15) Standby time for auxiliary equipment operation

Sets the standby time until the auxiliary equipment operation starts during primary equipment operation.

For details, refer to “Details of control output function” on page 1.

Function number	Setting value	Setting description	Factory setting
71	00	Disable	◆
	01	1 minute	
	02	2 minutes	
	•	•	
	•	•	
	•	•	
	98	98 minutes	
	99	99 minutes	

16) Heat pump backup setting

Enables or disables the heat pump backup instruction from the outdoor unit.

This function will be usable provided that the corresponding outdoor unit is connected.

Function number	Setting value	Setting description	Factory setting
72	00	Disable	◆
	01	Enable	

17) Emergency heat for external output terminal

Enables or disables emergency heat input.

Function number	Setting value	Setting description	Factory setting
73	00	Disable	◆
	01	Enable	

NOTE: When this function is used, IR receiver unit is necessary.

18) Fan delay time

Sets the fan delay time when the heater is turned off.

Function number	Setting value	Setting description	Factory setting
74	00	1 minute	◆
	01	50 seconds	
	02	40 seconds	
	03	30 seconds	

19) External heater use in defrosting

Enables or disables external heater use in defrosting.

NOTE: Inappropriate heater selection may cause cold air in defrosting.

Function number	Setting value	Setting description	Factory setting
75	00	Disable	◆
	01	Enable	

20) Airflow adjustment for operation mode

Strong or weak airflow can be set by $\pm 10\%$.

Since the airflow volume by motor has the upper limit and lower limit, up-down adjustment may not be performed depending on the models or settings even if this setting is performed.

Function number	Setting value	Setting description		Factory setting
		Cooling setting	Heating setting	
92	00	Standard (no change)	Standard (no change)	◆
	01	Standard (no change)	+10% up	
	02	Standard (no change)	-10% down	
	03	+10% up	Standard (no change)	
	04	+10% up	+10% up	
	05	+10% up	-10% down	
	06	-10% down	Standard (no change)	
	07	-10% down	+10% up	
	08	-10% down	-10% down	

21) Airflow adjustment at heater only operation

By selecting the heater output in the table below at heater only operation, this function adjusts the airflow volume according to the heater output to prevent cold air feeling.

Function number	Setting value	Setting description	Factory setting
		Heater output range	
93	00	No heater	◆
	01	0 — 3.4 kW (Min. CFM)	
	02	3.4 — 6.8 kW (350 CFM)	
	03	6.8 — 10.4 kW (710 CFM)	
	04	10.4 — 13.7 kW (1,070 CFM)	
	05	13.7 — 17.1 kW (1,410 CFM)	

2. Function settings Function settings (For outdoor unit)

Perform appropriate function setting locally according to the installation environment.

NOTE: Incorrect settings can cause a product malfunction.

⚠ CAUTION

- Before setting up the switch buttons, discharge the static electricity from your body.
- Never touch the terminals or the patterns on the parts that are mounted on the PCB.

2-1. Control PCB and switch buttons location

Control PCB of the outdoor unit is located as shown in the following figure.

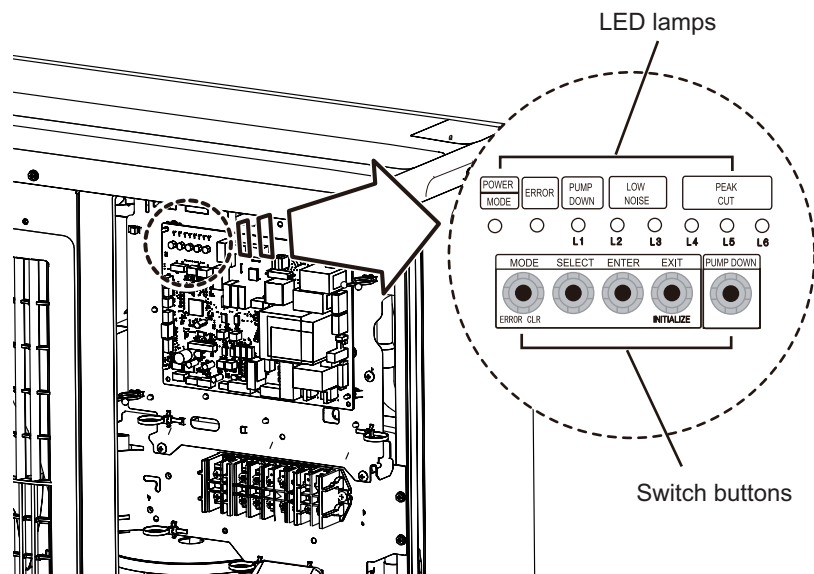

■ Switch buttons and the functions

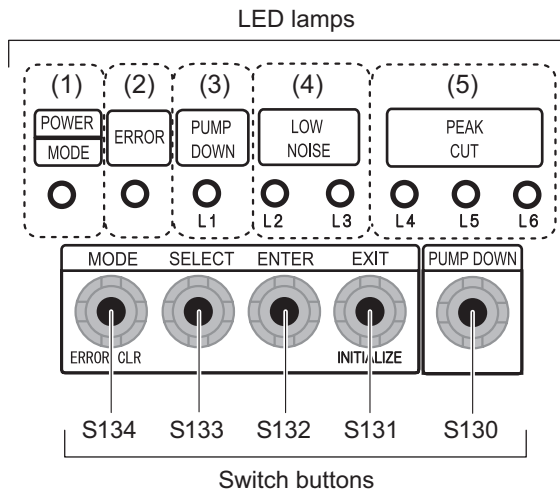

LED lamp			Function or operation method
(1)	POWER/MODE	Green	Lights on while power on. Local setting in outdoor unit or error code is displayed with blink.
(2)	ERROR	Red	Blinks during error operation.
(3)	PUMP DOWN (L1)	Orange	Lights on during pump down operation.
(4)	LOW NOISE MODE (L2 and L3)	Orange	Lights on during "Low noise mode" when local setting is activated. (Lighting pattern of L2 and L3 indicates low noise level.)
(5)	PEAK CUT MODE (L4, L5, and L6)	Orange	Lights on during "Peak cut mode" when local setting is activated. (Lighting pattern of L4, L5, and L6 indicates peak cut level.)

Switch button		Function or operation method
S134	MODE	Switches between "Local setting" and "Error code display".
S133	SELECT	Switches between the individual "Local settings" and the "Error code displays".
S132	ENTER	Switches between the individual "Local settings" and the "Error code displays".
S131	EXIT	Returns to "Operation status display".
S130	PUMP DOWN	Starts the pump down operation.

FIELD WORKING

FIELD WORKING

2-2. Local setting procedure

NOTE: Before performing the function setting, be sure to stop the operation of the air conditioner.

■ Low noise mode

1. Press the MODE switch button (S134) for 3 seconds or more to switch to “Local setting mode”.
2. After confirming the LED lamp of POWER/MODE blinks 9 times, press the ENTER switch button (S132).

POWER MODE	ERROR	PUMP DOWN (L1)	LOW NOISE (L2) (L3)		PEAK CUT (L4) (L5) (L6)		
Blinks (9 times)	○	○	○	○	○	○	○

Sign “○”: Lights off

3. Press the SELECT switch button (S133), and adjust the LED lamp as shown below. Then the LED lamp indicates the current setting.

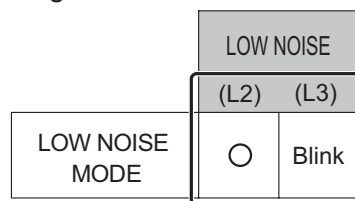

4. Press the ENTER switch button (S132).

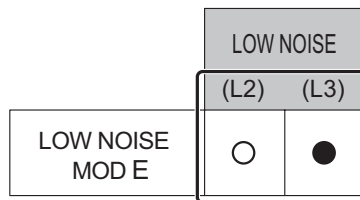

Sign “●”: Lights on

5. Press the SELECT switch button (S133), and adjust the LED lamps as shown below.

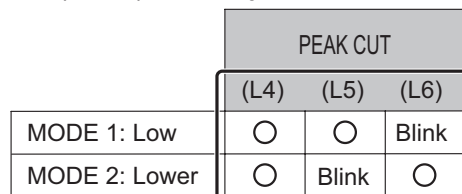

6. Press the ENTER switch button (S132) and fix it.

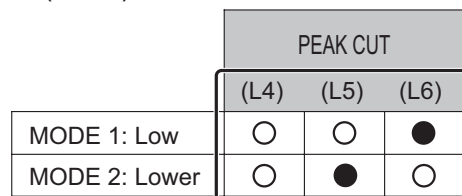

7. To return to “Operating status display (Normal operation)”, press the EXIT switch button (S131).

In case of missing how many times you pressed the SELECT and ENTER switch buttons:

1. To return to “Operation status display (Normal operation)”, press the EXIT switch button once.
2. Restart from the beginning of setting procedure.

NOTE: In case of missing how many times you pressed the SELECT and ENTER switch buttons, you must redo the setting procedure. Return to “Operation status display (Normal operation)” by pressing the EXIT switch button once, and restart from the beginning of the setting procedure.

■ Peak cut mode

1. Press the MODE switch button (S134) for 3 seconds or more to switch to “Local setting mode”.
2. After confirming the LED lamp of POWER/MODE blinks 9 times, press the ENTER switch button (S132).

POWER MODE	ERROR	PUMP DOWN (L1)	LOW NOISE		PEAK CUT		
			(L2)	(L3)	(L4)	(L5)	(L6)
Blinks (9 times)	○	○	○	○	○	○	○

Sign “○”: Lights off

3. Press the SELECT switch button (S133), and adjust the LED lamp as shown below. Then the LED lamp indicates the current setting.

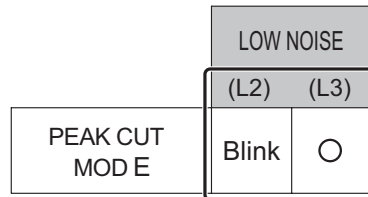

4. Press the ENTER switch button (S132).

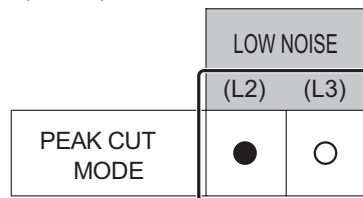

Sign “●”: Lights on

5. Press the SELECT switch button (S133), and adjust the LED lamps as shown below.

	PEAK CUT		
	(L4)	(L5)	(L6)
0 % of rated input ratio	○	○	Blink
50 % of rated input ratio	○	Blink	○
75 % of rated input ratio	○	Blink	Blink
100 % of rated input ratio	Blink	○	○

6. Press the ENTER switch button (S132) and fix it.

	PEAK CUT		
	(L4)	(L5)	(L6)
0 % of rated input ratio	○	○	●
50 % of rated input ratio	○	●	○
75 % of rated input ratio	○	●	●
100 % of rated input ratio	●	○	○

7. To return to “Operating status display (Normal operation)”, press the EXIT switch button (S131).

NOTE: When pressed number is lost during setting, you must redo the setting procedure. Return to “Operation status display (Normal operation)” by pressing the EXIT switch button once, and restart from the beginning of the setting procedure.

■ Maximum circuit breaker

1. Press the MODE switch button (S134) for 3 seconds or more to switch to “Local setting mode”.
2. After confirming the LED lamp of POWER/MODE blinks 9 times, press the ENTER switch button (S132).

POWER MODE	ERROR	PUMP DOWN (L1)	LOW NOISE		PEAK CUT		
			(L2)	(L3)	(L4)	(L5)	(L6)
Blinks (9 times)	○	○	○	○	○	○	○

Sign “○”: Lights off

3. Press the SELECT switch button (S133), and adjust the LED lamp as shown below. Then the LED lamp indicates the current setting.

	PUMP DOWN (L1)	LOW NOISE	
		(L2)	(L3)
Maximum circuit breaker	Blink	Blink	○

4. Press the ENTER switch button (S132).

	PUMP DOWN (L1)	LOW NOISE	
		(L2)	(L3)
Maximum circuit breaker	●	○	○

Sign “●”: Lights on

5. Press the SELECT switch button (S133), and adjust the LED lamps as shown below.

		PEAK CUT		
		(L4)	(L5)	(L6)
Mode 1	Standard	○	○	Blink
Mode 2	Depends on the model*	○	Blink	○

* Refer to the breaker capacity label.

6. Press the ENTER switch button (S132) and fix it.

		PEAK CUT		
		(L4)	(L5)	(L6)
Mode 1	Standard	○	○	●
Mode 2	Depends on the model	○	●	○

7. To return to “Operating status display (Normal operation)”, press the EXIT switch button (S131).

NOTES:

- When pressed number is lost during setting, you must redo the setting procedure. Return to “Operation status display (Normal operation)” by pressing the EXIT switch button once, and restart from the beginning of the setting procedure.
- Check the breaker capacity label after changing the setting.

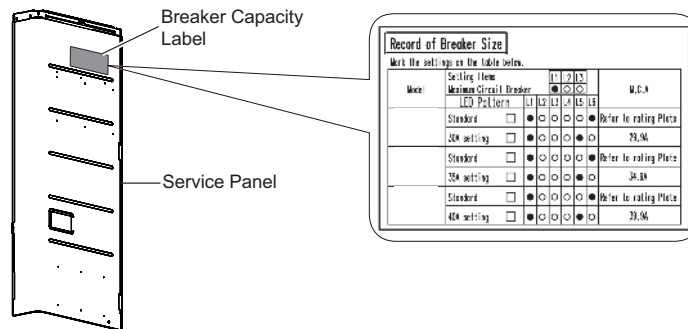

FIELD WORKING

FIELD WORKING

■ Base heater forced off

1. Press the MODE switch button (S134) for 3 seconds or more to switch to “Local setting mode”.
2. After confirming the LED lamp of POWER/MODE blinks 9 times, press the ENTER switch button (S132).

POWER MODE	ERROR	PUMP DOWN (L1)	LOW NOISE (L2) (L3)		PEAK CUT (L4) (L5) (L6)		
Blinks (9 times)	○	○	○	○	○	○	○

Sign “○”: Lights off

3. Press the SELECT switch button (S133), and adjust the LED lamp as shown below. Then the LED lamp indicates the current setting.

	PUMP DOWN (L1)	LOW NOISE (L2) (L3)	
Base heater forced off	Blink	○	Blink

4. Press the ENTER switch button (S132).

	PUMP DOWN (L1)	LOW NOISE (L2) (L3)	
Base heater forced off	●	○	●

Sign “●”: Lights on

5. Press the SELECT switch button (S133), and adjust the LED lamps as shown below.

		PEAK CUT (L4) (L5) (L6)		
Mode 1	Forced off	○	○	Blink
Mode 2	ON	○	Blink	○

6. Press the ENTER switch button (S132) and fix it.

		PEAK CUT (L4) (L5) (L6)		
Mode 1	Forced off	○	○	●
Mode 2	ON	○	●	○

7. To return to “Operating status display (Normal operation)”, press the EXIT switch button (S131).

NOTE: When pressed number is lost during setting, you must redo the setting procedure. Return to “Operation status display (Normal operation)” by pressing the EXIT switch button once, and restart from the beginning of the setting procedure.

3. External input and output

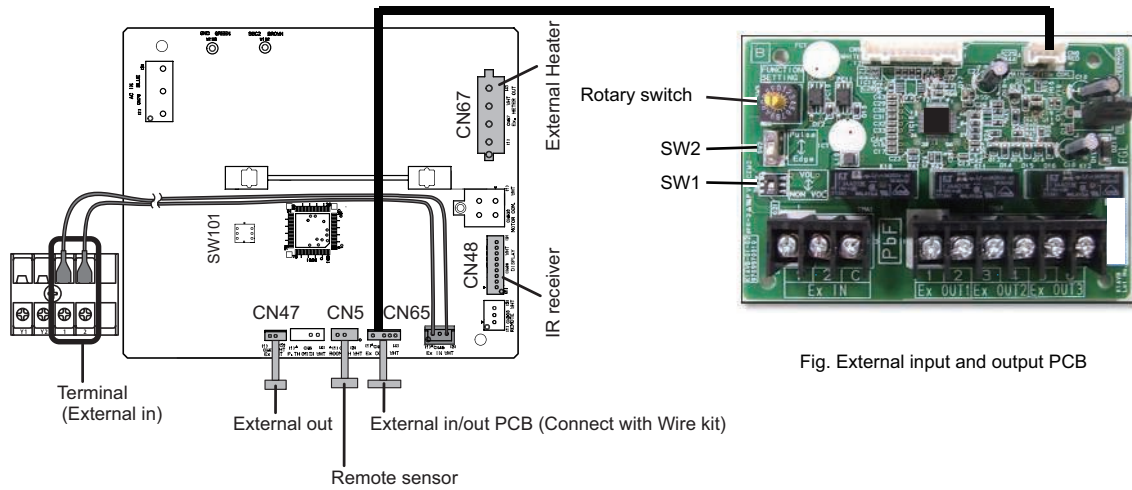

Fig. External input and output PCB

PCB	External input	External output	Connector	Input select	Input signal	External connect kit (Optional parts)
Indoor unit	Operation/Stop Forced stop	—	Terminal	Dry contact	Edge	—
	—	Operation status	CN47	—	—	UTY-XWZXZG
		Error status				
		Indoor unit fan operation status				
—	External heater output	CN47 CN67	—	—	—	
External input and output (UTY-XCSX)	Operation/Stop	—	Input 1/ Input 2	Dry contact/ Apply voltage	Edge/ Pulse	—
	Forced thermostat off		Input 1		Edge	
	—	Operation status	Output 1 Output 2 Output 3	—	—	—
		Error status				
Indoor unit fan operation status						
—	External heater output	—	—	—	—	

3-1. External input

- “Operation/Stop” mode or "Forced stop" mode can be selected with function setting of indoor unit.
- A twisted pair cable (22AWG) should be used. Maximum length of cable is 492 ft (150 m).
- The wire connection should be separate from the power cable line.

■ Indoor unit

Indoor unit functions such as Operation/Stop can be done by using indoor unit terminals.

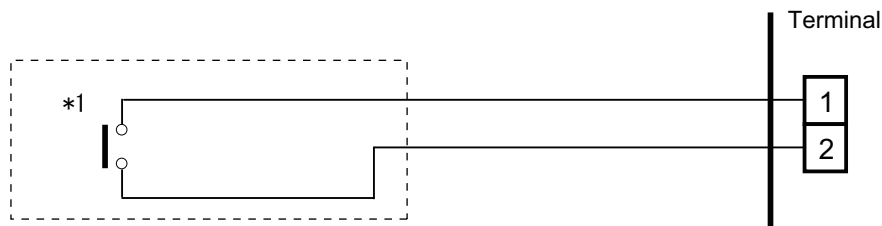

*1: The switch can be used on the following condition: DC 12 V to 24 V, 1 mA to 15 mA.

FIELD WORKING

FIELD WORKING

External input and output PCB

The indoor unit Operation/Stop can be set by using the input terminal on the PCB.

Input select

Use either one of these types of terminals according to the application. (Both types of terminals cannot be used simultaneously.)

- Dry contact

In case of internal power supply, set the slide switch of SW1 to "NON VOL" side.

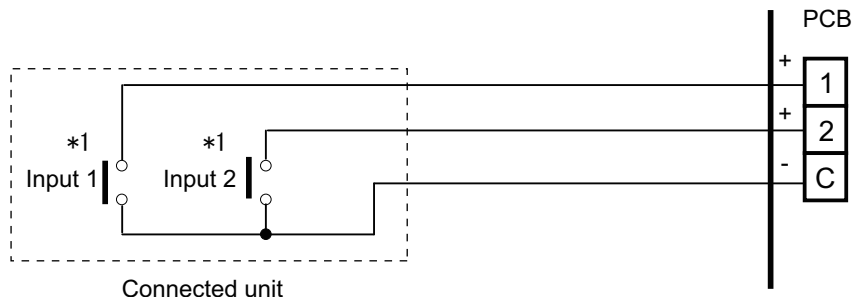

*1: The switches can be used on the following condition: DC 12 V to 24 V, 1 mA to 15 mA.

- Apply voltage

In case of external power supply, set the slide switch of SW1 to "VOL" side.

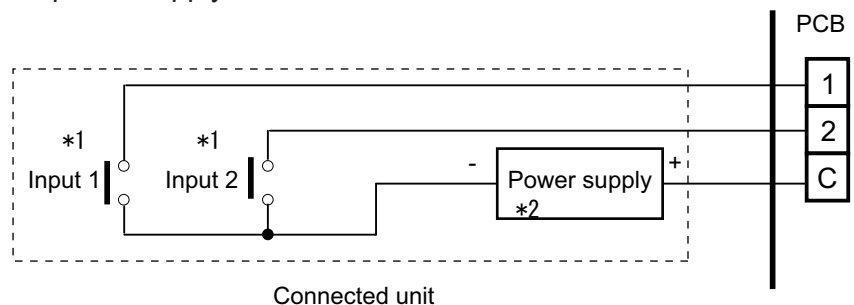

*1: The switches can be used on the following condition: DC 12 V to 24 V, 1 mA to 15 mA.

*2: Make the power supply DC 12 V to 24 V 10 mA or more.

3-2. External output

Use an external output cable with appropriate external dimension, depending on the number of cables to be installed.

■ Indoor unit

- A twisted pair cable (22AWG) should be used. Maximum length of cable is 82 ft (25 m).
- Output voltage: High DC 12 V \pm 2 V, Low 0 V.
- Permissible current: 50 mA
- For details, refer to [Chapter 3-3. "Combination of external input and output"](#) on page 05-21.

● When indicator, etc. are connected directly

Example: Function setting 60 is set to "00"

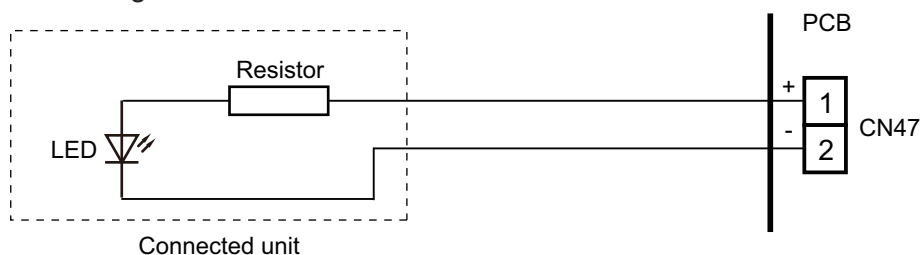

● When connecting with a device equipped with a power supply

Example: Function setting 60 is set to "00"

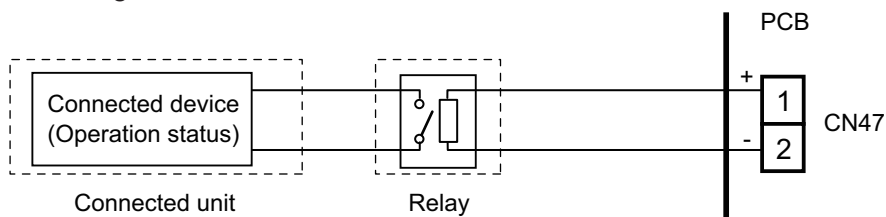

● When connecting with an external heater

Output voltage:	Heater ON: AC24V \pm 25% Heater OFF: Open
Permissible current:	500mA

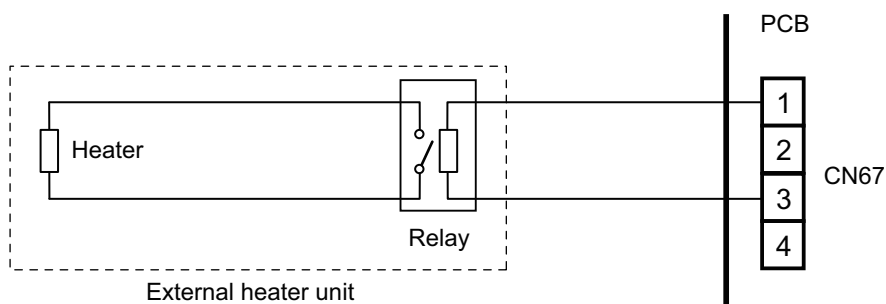

External input and output PCB

- A twisted pair cable (22AWG) should be used.
- Permissible voltage and current: DC 5 V to 30 V / 3 A, AC 30 V to 250 V / 3 A
- For details, refer to [Chapter 3-3. "Combination of external input and output"](#) on page 05-21.

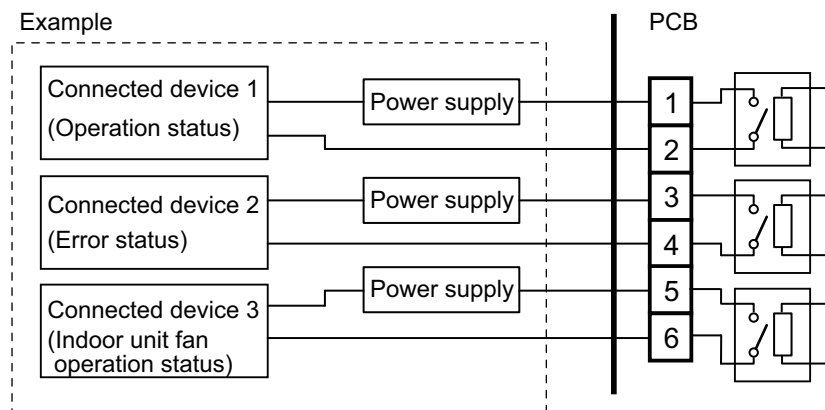

3-3. Combination of external input and output

By combining the function setting of the indoor unit and rotary switch setting of the External input and output PCB, you can select various combinations of functions.

Combination examples of external input and output are as follows:

Mode	Function setting	External input and output PCB (Rotary SW)	External input			
			Indoor unit Input	External input and output PCB		
			Terminal	Input 1	Input 2	Signal type
0-1	60-00	1	Operation/Stop (Function setting 46-00) or Forced stop (Function setting 46-02)	Operation/Stop	Not available	Edge
				Operation	Stop	Pulse
0-2	60-00	2		Forced Thermostat OFF	Not available	Edge
1	60-01	3		Mechanical cooling Off		
2	60-02	4		Forced thermostat Off		
3	60-03	5		Mechanical cooling On		
4	60-04	6		Mechanical cooling On		
5	60-05	7		Forced thermostat Off		
6	60-06	8		Forced thermostat Off		
7	60-07	9		Mechanical cooling Off		
8	60-08	A		Forced thermostat Off		
9	60-09	B		Forced Thermostat OFF		
10	60-10	C	Forced Thermostat OFF			
11	60-11	D	Forced Thermostat OFF			
12	60-12	D	Forced Thermostat OFF			

Mode	Function setting	External input and output PCB (Rotary SW)	External output			
			Indoor unit Output	External input and output PCB		
			CN47	Output 1	Output 2	Output 3
0-1	60-00	1	Operation/Stop	Operation/Stop	Error status	Indoor unit fan operation status
0-2	60-00	2	Operation/Stop	Error status	Indoor unit fan operation status	External heater output
1	60-01	3	Cooling thermostat On	Error status	Indoor unit fan operation status	External heater output
2	60-02	4	Cooling thermostat On	Error status	Remote controller output	External heater output
3	60-03	5	Cooling thermostat On	Cooling high/low output	Remote controller output	External heater output
4	60-04	6	Cooling thermostat On	Error status	Remote controller output	Cooling high/low output
5	60-05	7	Heating thermostat On	Error status	Indoor unit fan operation status	External heater output
6	60-06	8	Operation/Stop	Error status	Indoor unit fan operation status	Heating thermostat On
7	60-07	9	Cooling thermostat On	Error status	Heating thermostat On	External heater output
8	60-08	A	Cooling thermostat On	Heating thermostat On	Remote controller output	External heater output
9	60-09	B	Error status	Operation/Stop	Indoor unit fan operation status	External heater output
10	60-10	C	Indoor unit fan operation status	Operation/Stop	Error status	External heater output
11	60-11	D	External heater output	Operation/Stop	Indoor unit fan operation status	Error status
12	60-12	D	Set point attainment status	Operation/Stop	Indoor unit fan operation status	Error status

NOTE: Input of Operation/Stop depends on the setting of function setting 46.

00: Operation/Stop mode 1 (R.C. enabled)

01: (Setting prohibited)

02: Forced stop

03: Operation/Stop mode 2 (R.C. disabled)

■ Input signal type

- Indoor unit
Input signal type is only "Edge".

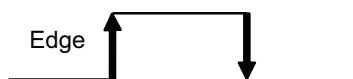

- External input and output PCB
The input signal type can be selected.
Signal type (edge or pulse) can be switched by the DIP switch 2 (SW2) on the External input and output PCB.

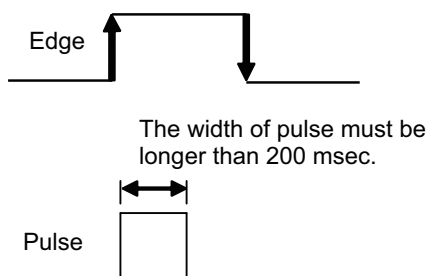

3-4. Details of function

■ Control input function

● When function setting is "Operation/Stop" mode 1

- In the case of "Edge" input

Function setting /	Rotary SW of External input and output PCB	External input		Input signal	Command
46-00	-	Input of indoor unit	Terminal	Off → On	Operation
				On → Off	Stop
	60-00 / 1	External input and output PCB	Input 1	Off → On	Operation
				On → Off	Stop

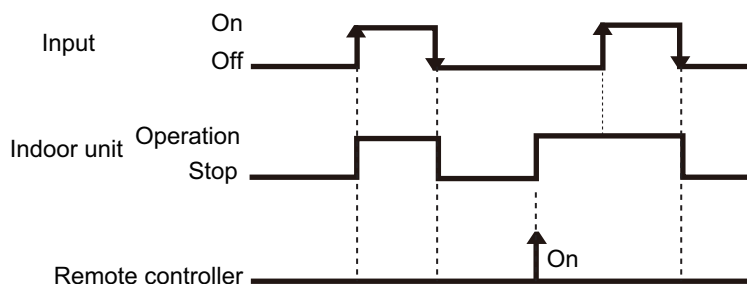

- In the case of "Pulse" input

Function setting /	Rotary SW of External input and output PCB	External input		Input signal	Command
46-00	60-00 / 1	External input and output PCB	Input 1	Pulse	Operation
			Input 2	Pulse	Stop

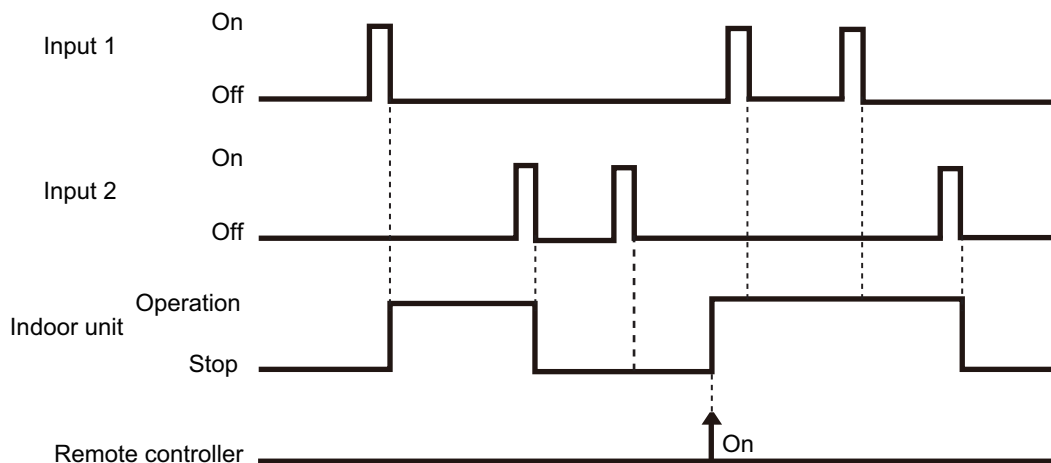

NOTES:

- The last command has priority.
- The indoor units within the same remote controller group operates in the same mode.

FIELD WORKING

FIELD WORKING

● When function setting is "Forced stop" mode

- In the case of "Edge" input

Function setting /		Rotary SW of External input and output PCB	External input		Input signal	Command
46-02	-		Input of indoor unit	Terminal	Off → On	Forced stop
					On → Off	Normal
	60-00 / 1	External input and output PCB	Input 1	Off → On	Forced stop	
				On → Off	Normal	

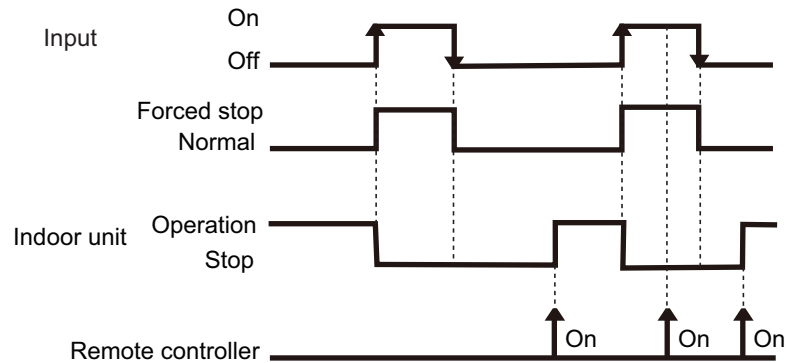

- In the case of "Pulse" input

Function setting /		Rotary SW of External input and output PCB	External input		Input signal	Command
46-02	60-00 / 1	External input and output PCB	Input 1	Pulse	Forced stop	
			Input 2	Pulse	Normal	

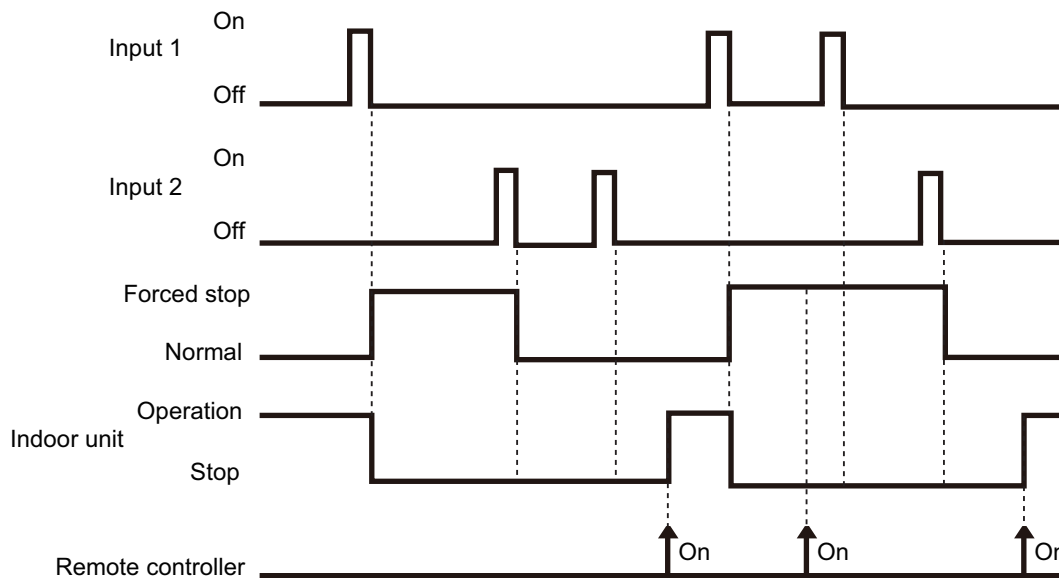

NOTES:

- When the forced stop is triggered, indoor unit stops and Operation/Stop operation by the remote controller is restricted.
- When forced stop function is used with forming a remote controller group, connect the same equipment to each indoor unit within the group.

● When function setting is "Operation/Stop" mode 2

- In the case of "Edge" input

Function setting /	Rotary SW of External input and output PCB	External input		Input signal	Command
46-03	-	Input of indoor unit	Terminal	Off → On	Operation
				On → Off	Stop (R.C. disabled)
	60-00 / 1	External input and output PCB	Input 1	Off → On	Operation
				On → Off	Stop (R.C. disabled)

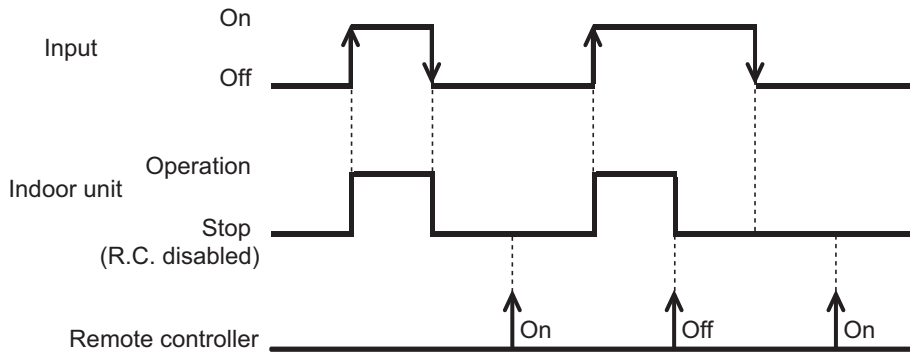

- In the case of "Pulse" input

Function setting /	Rotary SW of External input and output PCB	External input		Input signal	Command
46-03	60-00 / 1	External input and output PCB	Input 1	Pulse	Operation
			Input 2	Pulse	Stop (R.C. disabled)

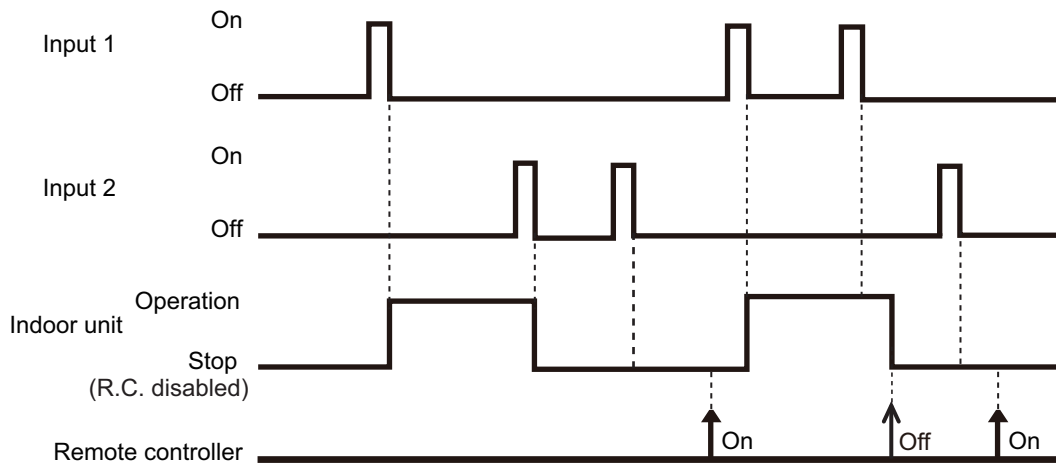

NOTES:

- When "Operation/Stop" mode 2 function is used with forming a remote controller group, connect the same equipment to each indoor unit within the group.

■ Forced thermostat off function

Function setting /	Rotary SW of External input and output PCB	External input		Input signal	Command
60-00 / 2 60-02 / 4 60-05 / 7 60-06 / 8 60-08 / A 60-09 / B 60-10 / C 60-11 / D		External input and output PCB	Input 1	Off → On	Thermostat off
				On → Off	Normal operation

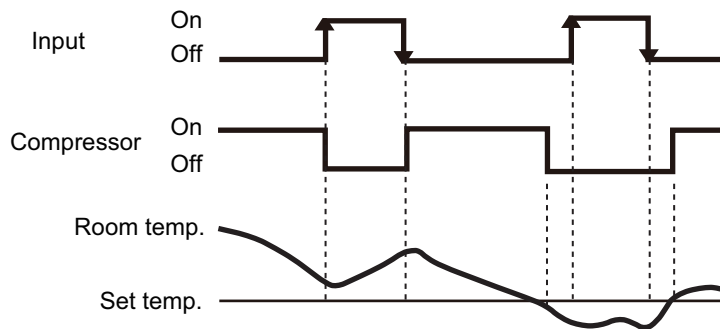

■ Control output function

Function setting /	Rotary SW of External input and output PCB	External output		Output signal	Command
60-00 / 1, 2 60-06 / 8		Output of indoor unit	CN47	Low → High	Operation
				High → Low	Stop
60-00 / 1 60-09 / B 60-10 / C 60-11 / D		External input and output PCB	Output 1	Off → On	Operation
				On → Off	Stop

The output is low when the unit is stopped.

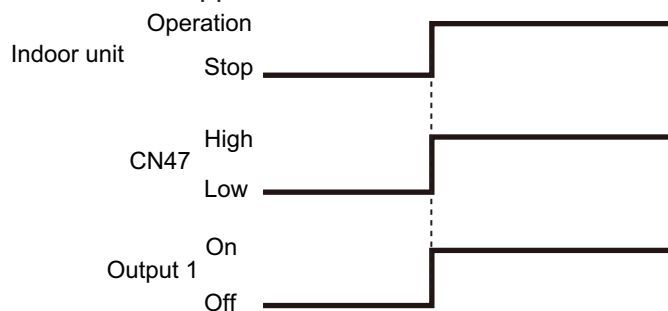

■ Error status

Function setting /	Rotary SW of External input and output PCB	External output		Output signal	Command		
60-09 / B		Output of indoor unit	CN47	Low → High	Error		
				High → Low	Normal		
60-00 / 2 60-01 / 3 60-02 / 4 60-04 / 6 60-05 / 7 60-06 / 8 60-07 / 9	External input and output PCB		Output 1	Off → On	Error		
On → Off				Normal			
60-00 / 1 60-10 / C					Output 2	Off → On	Error
						On → Off	Normal
60-11 / D					Output 3	Off → On	Error
						On → Off	Normal

The output is ON when an error is generated for the indoor unit.

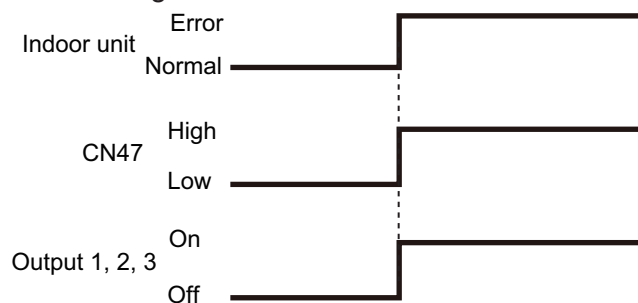

■ Indoor unit fan operation status

Function setting / Rotary SW of External input and output PCB	External output		Output signal	Command
60-10 / C	Output of indoor unit	CN47	Low → High	Fan run
			High → Low	Fan stop
60-00 / 2 60-01 / 3 60-05 / 7 60-06 / 8 60-09 / B 60-11 / D	External input and output PCB	Output 2	Off → On	Fan run
			On → Off	Fan stop
			Off → On	Fan run
			On → Off	Fan stop
60-00 / 1		Output 3	Off → On	Fan run
			On → Off	Fan stop

Output signal	Condition
On Low → High	The indoor unit fan is operating.
Off High → Low	The fan is stopped or during cold air prevention. During thermostat off when in dry mode operation.

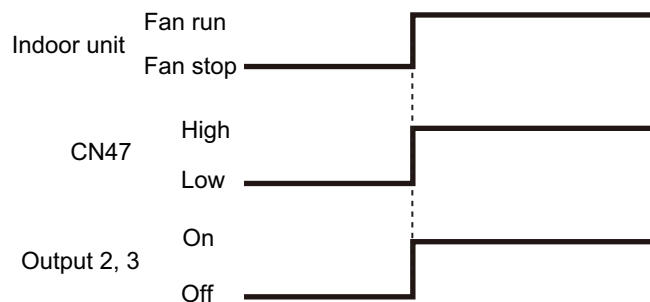

External heater output

Control	Primary heater	Auxiliary heater	Function setting	
			Indoor unit	Wired R. C.
			Control switching external heaters No. 61	Sensor activation*2
Auxiliary heater control 1	Heat pump	External device*1	61-00	—
Auxiliary heater control 2	Heat pump	External device	61-01	—
Heat pump prohibition control	External device	None	61-02	On (Enabled)
Auxiliary heater control by outdoor temperature 1	Heat pump	External device	61-03	On (Enabled)
Auxiliary heater control by outdoor temperature 2	Heat Pump	External device	61-04	On (Enabled)
Auxiliary heater control by outdoor temperature 3	Heat Pump	External device	61-05	On (Enabled)
Auxiliary heat pump control	External device	Heat pump	61-06	On (Enabled)
Auxiliary heat pump control by outdoor temperature 1	External device	Heat pump	61-07	On (Enabled)
Auxiliary heat pump control by outdoor temperature 2	External device	Heat pump	61-08	On (Enabled)
Auxiliary heat pump control by outdoor temperature 3	External device	Heat pump	61-09	On (Enabled)

NOTES:

- After turning off the heater, 3 minutes of standby time is required by next power-on of the heater.
- For items marked “—” in the table, any of validate or invalidate of the setting are acceptable.
- *1: External device means Hot water, Electrical heater, etc.
- *2: Sensor activation:
 - Setting change from the factory setting is required.
 - Indoor unit fan setting will be on for safety reason without sensor activation of wired remote controller.

● Installation configuration of individual connection

External heating device is installed individually. (No use of indoor unit fan)

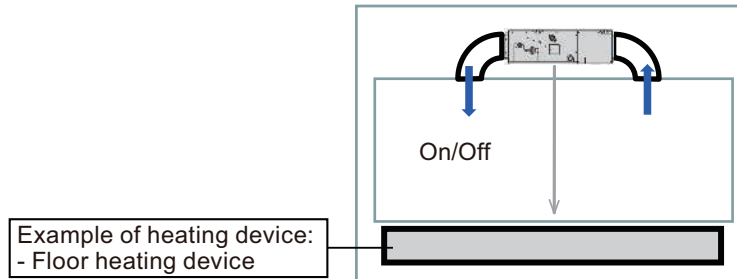

⚠ WARNING

- **DIP Switch 101-3 must be in the ON position when ducted electric heat application is being used.** DIP switch 101-3 is set in the ON position by default from the factory. When DIP switch 101-3 is in the ON position and ducted electric heat application is not being used, cold draft occurs due to fan delay off operation.

Operation			Condition
Heater off	DIP-SW101-3	On	<ul style="list-style-type: none"> • Heater is off as shown in following diagram of heating temperature.
	Indoor unit fan setting for external heater	Enabled	<ul style="list-style-type: none"> • Other than heating mode • Error occurred • Forced thermostat off • Fan stop protection
Heater off	DIP-SW101-3	Off	<ul style="list-style-type: none"> • Heater is off as shown in following diagram of heating temperature.
	Indoor unit fan setting for external heater	Disabled	<ul style="list-style-type: none"> • Other than heating mode • Error occurred • Forced thermostat off

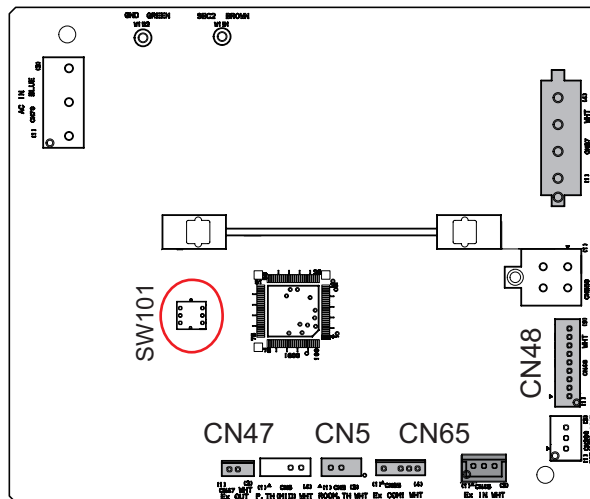

- Design and install external heater appropriately with considering its protection.

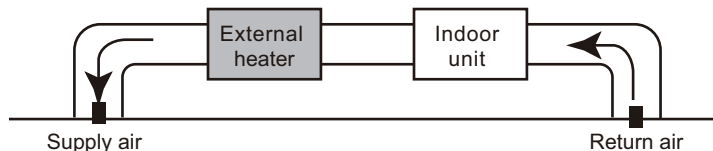

- Inappropriate designing and installation of external heater may cause a fire by emitted heat from the external heater.
- Fujitsu General Ltd. is not responsible for inappropriate designing or installation of external heating device.

FIELD WORKING

FIELD WORKING

● Auxiliary equipment control by room temperature

Auxiliary equipment control is switchable by room temperature. Auxiliary equipment switching is performed for each room temperature divided to following 3 zones.

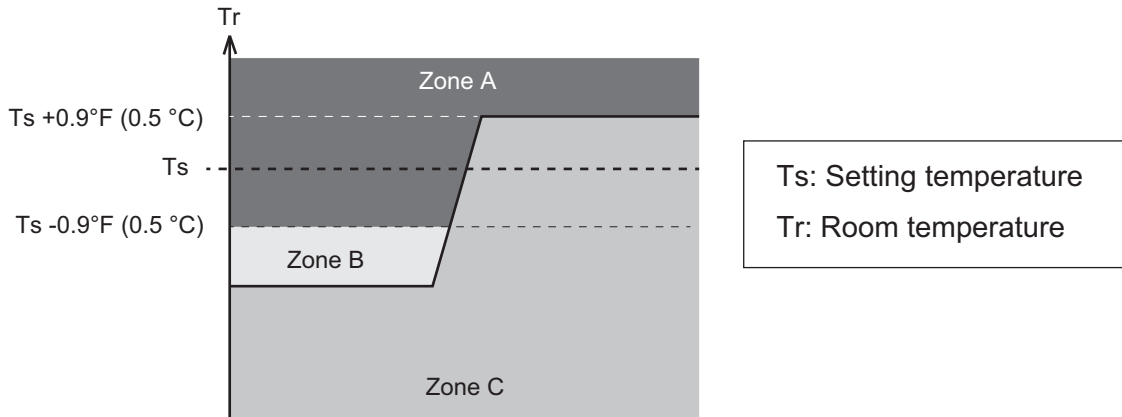

Zone	Application	When temperature dropping		When temperature rising	
		Primary	Auxiliary	Primary	Auxiliary
A	Both of primary and auxiliary equipment is unnecessary.	Off	Off	Off	Off
B	Primary heater only. When room temperature stays in zone B for a long time, auxiliary equipment also operates.	On	Off*1	—	—
C	Auxiliary equipment also operates.	On	On*2	On	On*2

*1: For standby time for auxiliary equipment operation, refer to indoor unit function number 71 "[Contents of function setting](#)" on page 05-2.

*2: When indoor unit function number 61 is set to "00", auxiliary equipment operates according to the following conditions.

- $T_s - T_r > 21.6 \text{ }^\circ\text{F}$ ($-12.0 \text{ }^\circ\text{C}$): Auxiliary equipment turn off.
- $T_s - T_r > 18.0 \text{ }^\circ\text{F}$ ($-10.0 \text{ }^\circ\text{C}$): Auxiliary equipment turn on.

● Auxiliary heater control 1

Operation	Condition
Heater on	Heater is on as shown in following diagram of heating temperature.
Heater off	<ul style="list-style-type: none"> • Heater is off as shown in following diagram of heating temperature. • Other than heating mode • Error occurred • Forced thermostat off • Fan stop protection

- Temperature of heater on (Thon): Adjustable by function number 62 (Operating temperature switching of external heaters).
- All control temperatures will shift by adjusting “Thon”.

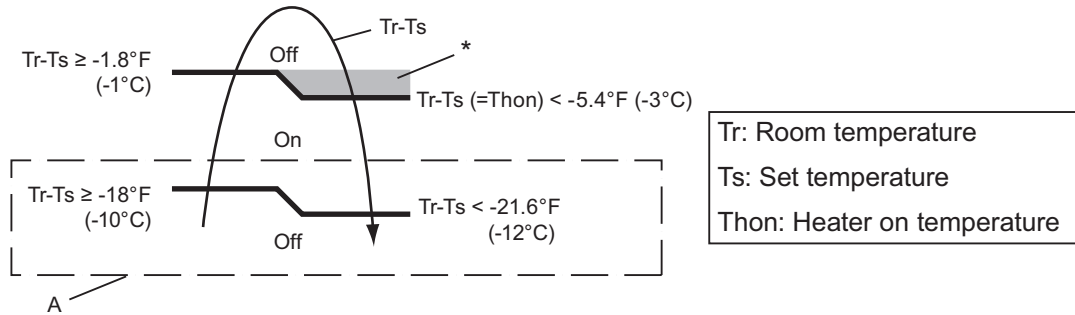

*: When room temperature stays in this zone for a specific time, auxiliary heater is turned on. For details, refer to function number 71.

Example: When set temperature (Ts) is 72°F (22°C) (Factory setting),

- and room temperature (Tr) increases above 53.6°F (12°C), signal output is on.
- and room temperature (Tr) increases above 69.8°F (21°C), signal output is off.
- and room temperature (Tr) decreases below 66.2°F (19°C), signal output is on.
- and room temperature (Tr) decreases below 50°F (10°C), signal output is off.

● Auxiliary heater control 2

Control that excludes “A” from "Auxiliary heater control 1" on page 05-33.

Operation	Condition
Heater on	Heater is on as shown in following diagram of heating temperature.
Heater off	<ul style="list-style-type: none"> • Heater is off as shown in following diagram of heating temperature. • Other than heating mode • Error occurred • Forced thermostat off • Fan stop protection

- Temperature of heater on (Thon): Adjustable by function number 62 (Operating temperature switching of external heaters).
- All control temperatures will shift by adjusting “Thon”.

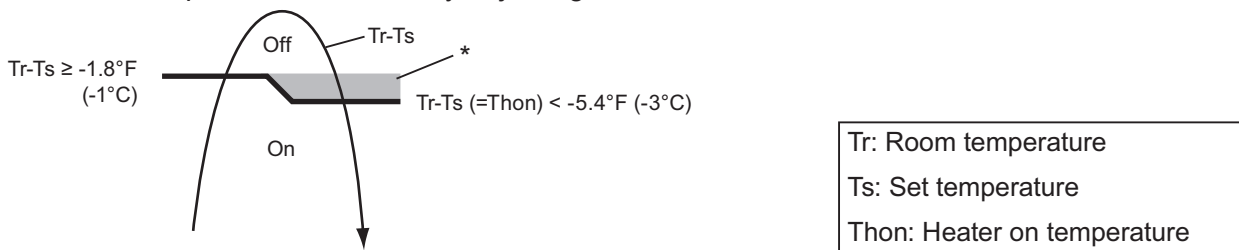

*: When room temperature stays in this zone for a specific time, auxiliary heater is turned on. For details, refer to function number 71.

FIELD WORKING

FIELD WORKING

● Heat pump prohibition control

Perform heating by external heater only. Indoor unit is continuous thermostat off.

Operation			Condition
Heater on			Heater is on as shown in following diagram of heating temperature.
Heater off	DIP-SW101-3 On Indoor unit fan setting for external heater Enabled	On	<ul style="list-style-type: none"> • Heater is off as shown in following diagram of heating temperature. • Other than heating mode • Error occurred • Forced thermostat off • Fan stop protection
	DIP-SW101-3 Off Indoor unit fan setting for external heater Disabled	Off	<ul style="list-style-type: none"> • Heater is off as shown in following diagram of heating temperature. • Other than heating mode • Error occurred • Forced thermostat off

- Temperature of heater on (Thon): Adjustable by function number 62 (Operating temperature switching of external heaters).
- All control temperatures will shift by adjusting “Thon”.

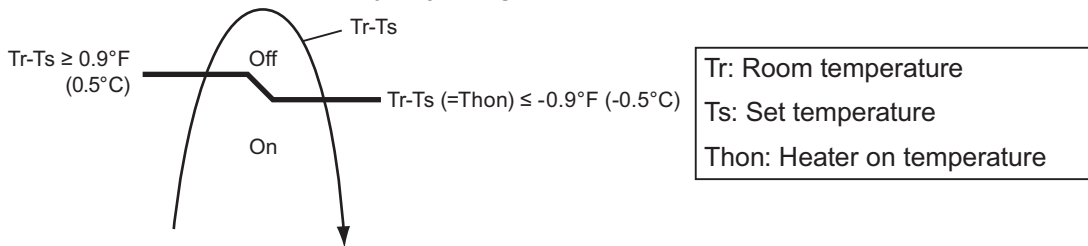

• Operation status

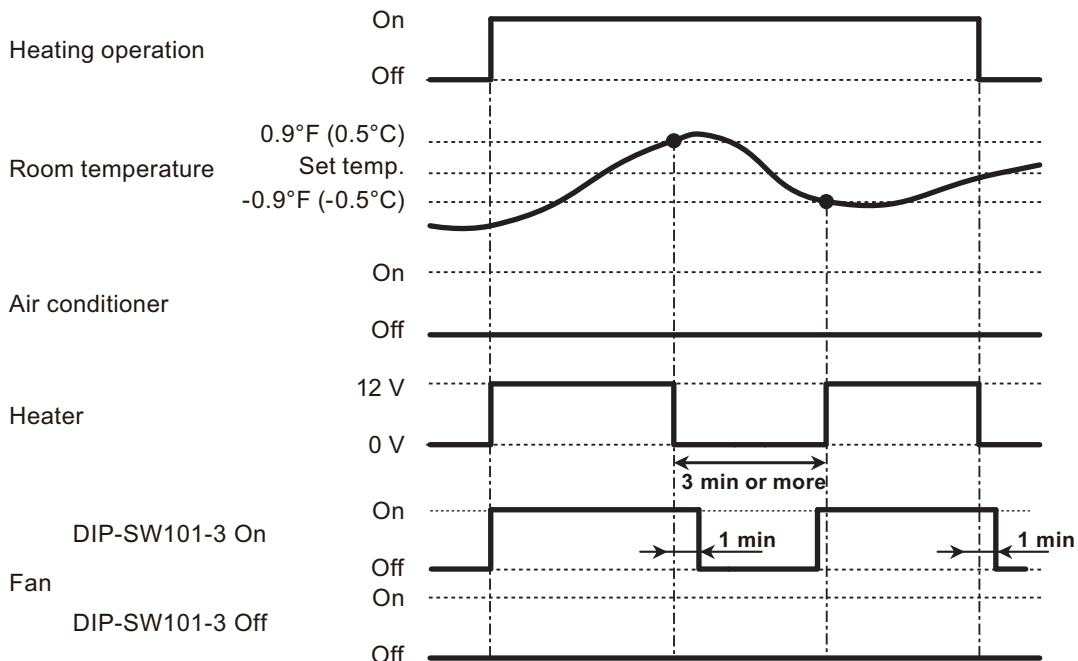

NOTE: In following operations, compressor will be on.

- Other than heating
- Test run

● Auxiliary heater control by outdoor temperature 1

This control selects heat pump or external heater according to the outdoor temperature. When outdoor temperature is high, the heating is performed by using heat pump only.

Operation			Condition
Heater on			Heater is on as shown in following diagram of heating temperature.
Heater off	DIP-SW101-3 Indoor unit fan setting for external heater	On Enabled	<ul style="list-style-type: none"> • Heater is off as shown in following diagram of heating temperature. • Other than heating mode • Error occurred • Forced thermostat off • Heat pump only zone • Fan stop protection
	DIP-SW101-3 Indoor unit fan setting for external heater	Off Disabled	<ul style="list-style-type: none"> • Heater is off as shown in following diagram of heating temperature. • Other than heating mode • Error occurred • Forced thermostat off • Heat pump only zone

- Temperature of heater on (Thon): Adjustable by function number 62 (Operating temperature switching of external heaters).
- All control temperatures will shift by adjusting "Thon".
- Outdoor temperature zone boundary A and B: Adjustable individually by function setting number 66 and 67.

• External heater output

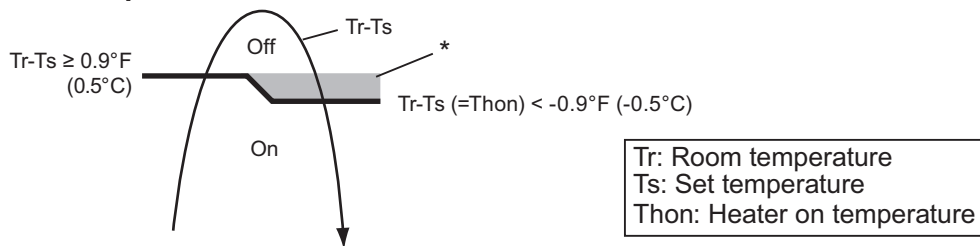

*: When room temperature stays in this zone for a specific time, auxiliary heater is turned on. For details, refer to function number 71.

• Outdoor temperature zone

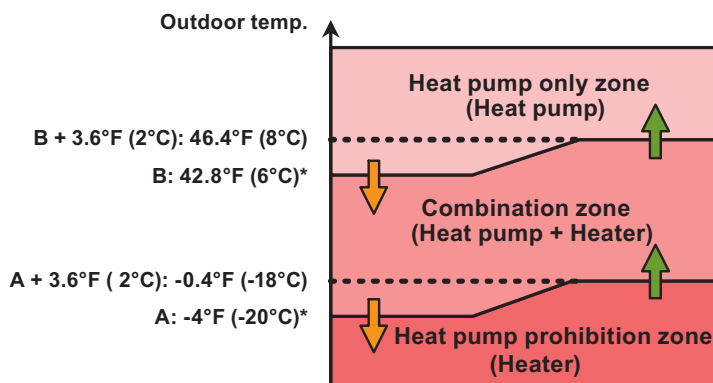

*: Adjustable by function setting 66 and 67

• Operation status

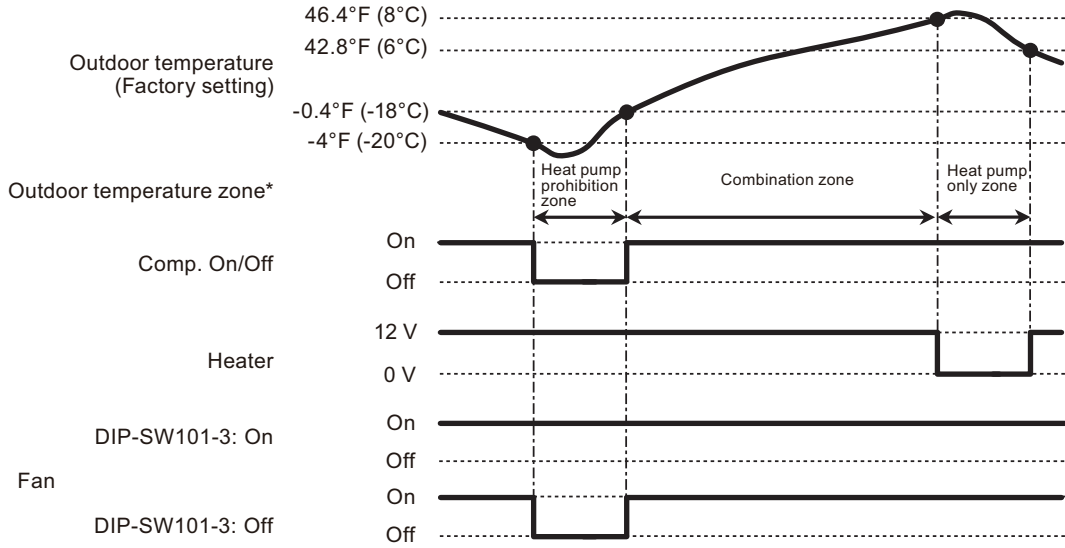

*: The outdoor temperature zone transition from one to another will stay in that zone for minimum of 30 min.

NOTE: In following operations, compressor will be on in heat pump prohibition zone.

- Other than heating
- Test run

FIELD WORKING

FIELD WORKING

● Auxiliary heater control by outdoor temperature 2

This control selects heat pump or external heater according to the outdoor temperature. Even when outdoor temperature is high, the heating is performed by using both of heat pump and external heater.

Operation			Condition
Heater on			Heater is on as shown in following diagram of heating temperature.
Heater off	DIP-SW101-3 Indoor unit fan setting for external heater	On Enabled	<ul style="list-style-type: none"> • Heater is off as shown in following diagram of heating temperature. • Other than heating mode • Error occurred • Forced thermostat off • Fan stop protection
	DIP-SW101-3 Indoor unit fan setting for external heater	Off Disabled	<ul style="list-style-type: none"> • Heater is off as shown in following diagram of heating temperature. • Other than heating mode • Error occurred • Forced thermostat off

- Temperature of heater on (Thon): Adjustable by function number 62 (Operating temperature switching of external heaters).
- All control temperatures will shift by adjusting “Thon”.
- Outdoor temperature zone boundary A: Adjustable by function setting number 66.

• External heater output

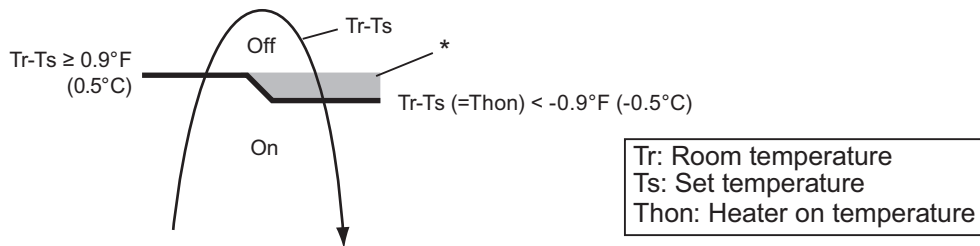

*: When room temperature stays in this zone for a specific time, auxiliary heater is turned on. For details, refer to function number 71.

• Outdoor temperature zone

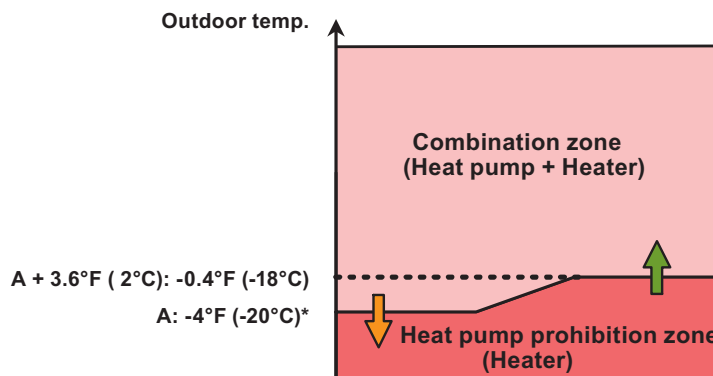

*: Adjustable by function setting 66

• Operation status

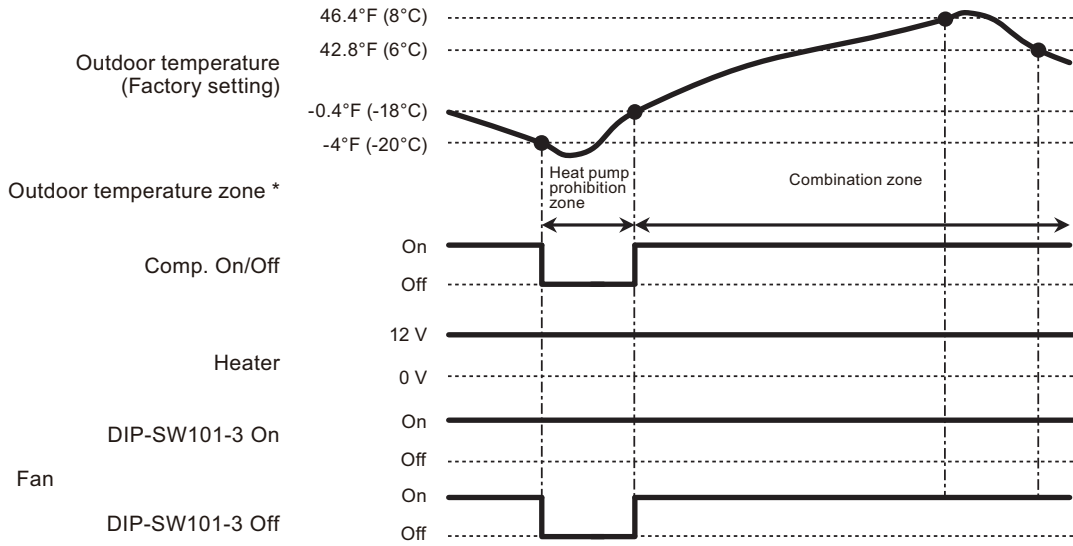

* The outdoor temperature zone transition from one to another will stay in that zone for minimum of 30 min.

NOTE: In following operations, compressor will be on in heat pump prohibition zone.

- Other than heating
- Test run

FIELD WORKING

FIELD WORKING

● Auxiliary heater control by outdoor temperature 3

This control selects heat pump or external heater according to the outdoor temperature. Even when outdoor temperature is high, the heating is performed by using both of heat pump and external heater.

Operation			Condition
Heater on			Heater is on as shown in following diagram of heating temperature.
Heater off	DIP-SW101-3 Indoor unit fan setting for external heater	On Enabled	<ul style="list-style-type: none"> • Heater is off as shown in following diagram of heating temperature. • Other than heating mode • Error occurred • Forced thermostat off • Fan stop protection
	DIP-SW101-3 Indoor unit fan setting for external heater	Off Disabled	<ul style="list-style-type: none"> • Heater is off as shown in following diagram of heating temperature. • Other than heating mode • Error occurred • Forced thermostat off

- Temperature of heater on (Thon): Adjustable by function number 62 (Operating temperature switching of external heaters).
- All control temperatures will shift by adjusting “Thon”.
- Outdoor temperature zone boundary B: Adjustable by function setting number 67.

• External heater output

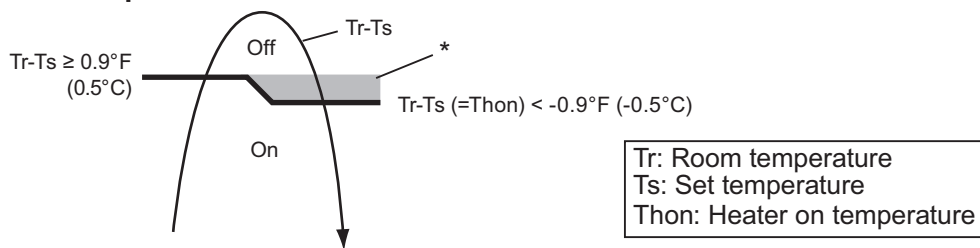

*: When room temperature stays in this zone for a specific time, auxiliary heater is turned on. For details, refer to function number 71.

• Outdoor temperature zone

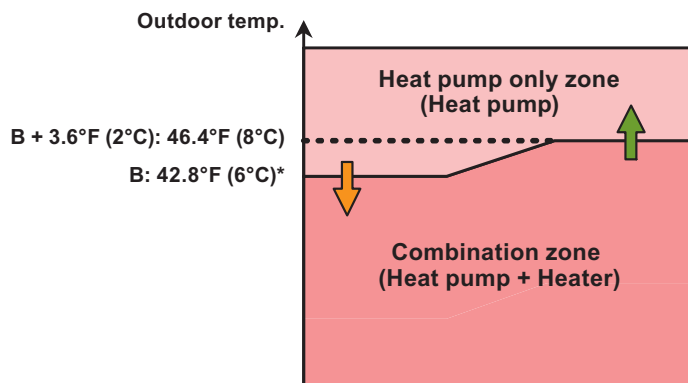

*: Adjustable by function setting 67

• Operation status

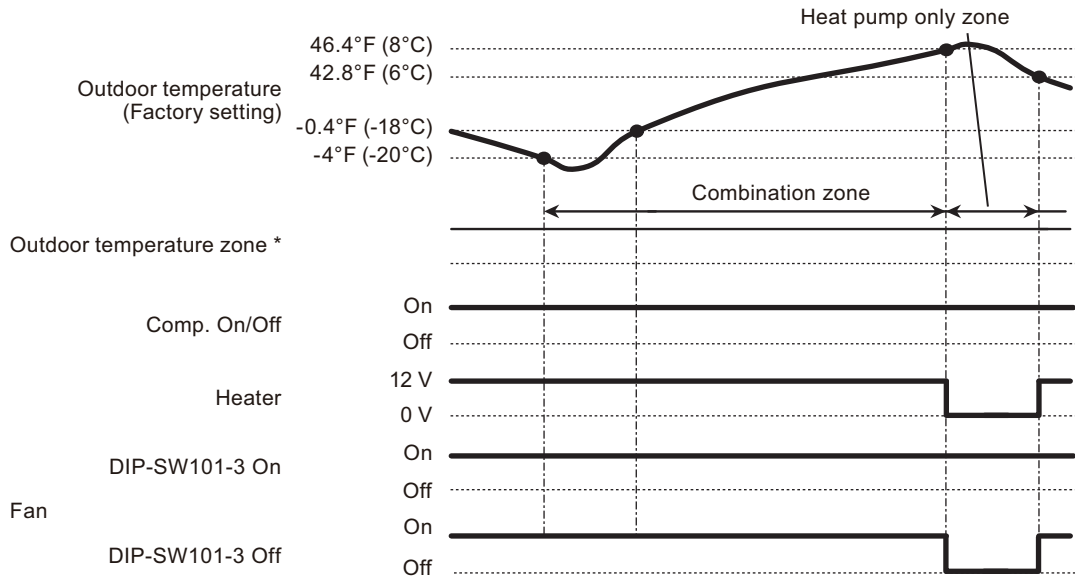

*: The outdoor temperature zone transition from one to another will stay in that zone for minimum of 30 min.

NOTE: In following operations, compressor will be on in heat pump prohibition zone.

- Other than heating
- Test run

FIELD WORKING

FIELD WORKING

● Auxiliary heat pump control

• External heater output

Operation			Condition
Heater on			Heater is on as shown in following diagram of heating temperature.
Heater off	DIP-SW101-3 Indoor unit fan setting for external heater	On Enabled	<ul style="list-style-type: none"> • Heater is off as shown in following diagram of heating temperature. • Other than heating mode • Error occurred • Forced thermostat off • Fan stop protection
	DIP-SW101-3 Indoor unit fan setting for external heater	Off Disabled	<ul style="list-style-type: none"> • Heater is off as shown in following diagram of heating temperature. • Other than heating mode • Error occurred • Forced thermostat off

- Temperature of heater on (Thon): Set temperature (Ts) - 0.9 °F (- 0.5 °C)
- Temperature of heater off: Set temperature (Ts) + 0.9 °F (+ 0.5 °C)

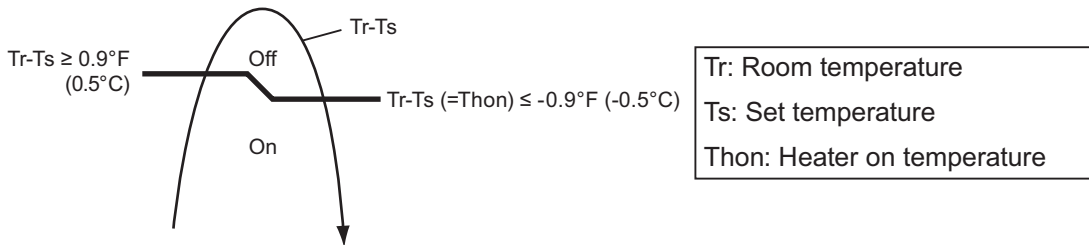

• Auxiliary heat pump On/Off

- Temperature of heater on (Thon): Adjustable by function number 62 (Operating temperature switching of heat pump).
- All control temperatures will shift by adjusting “Thon”.

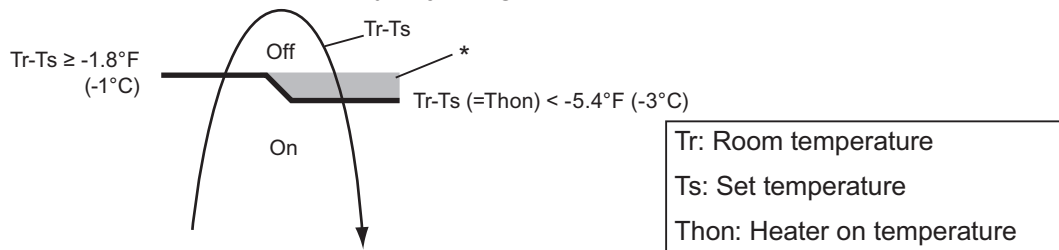

*: When room temperature stays in this zone for a specific time, auxiliary heater is turned on. For details, refer to function number 71.

● Auxiliary heat pump control by outdoor temperature 1

• External heater output

Operation			Condition
Heater on			Heater is on as shown in following diagram of heating temperature.
Heater off	DIP-SW101-3 Indoor unit fan setting for external heater	On Enabled	<ul style="list-style-type: none"> • Heater is off as shown in following diagram of heating temperature. • Other than heating mode • Error occurred • Forced thermostat off • Fan stop protection
	DIP-SW101-3 Indoor unit fan setting for external heater	Off Disabled	<ul style="list-style-type: none"> • Heater is off as shown in following diagram of heating temperature. • Other than heating mode • Error occurred • Forced thermostat off

- Temperature of heater on (Thon): Set temperature (Ts) - 0.9 °F (- 0.5 °C)
- Temperature of heater off: Set temperature (Ts) + 0.9 °F (+ 0.5 °C)

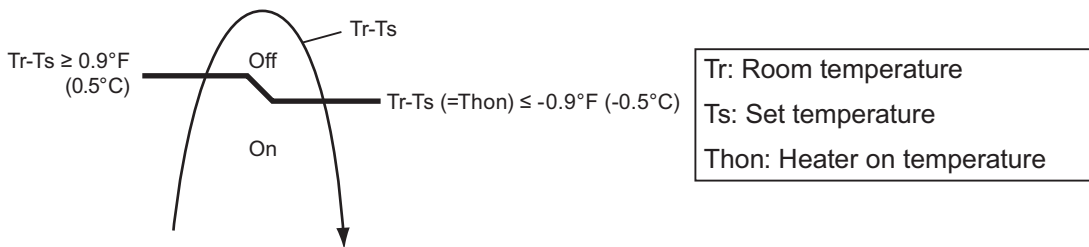

• Auxiliary heat pump On/Off

- Temperature of heater on (Thon): Adjustable by function number 62 (Operating temperature switching of heat pump).
- All control temperatures will shift by adjusting “Thon”.

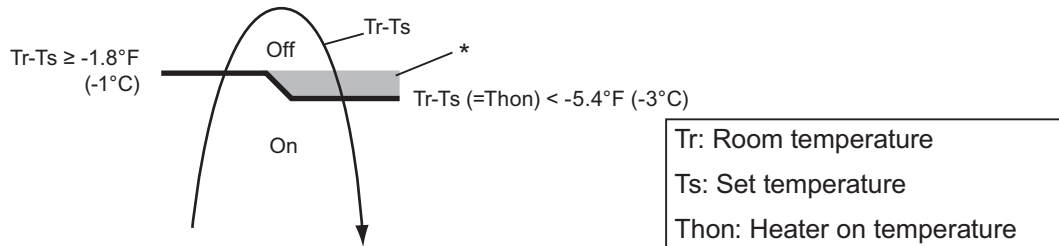

*: When room temperature stays in this zone for a specific time, auxiliary heater is turned on. For details, refer to function number 71.

• Outdoor temperature zone

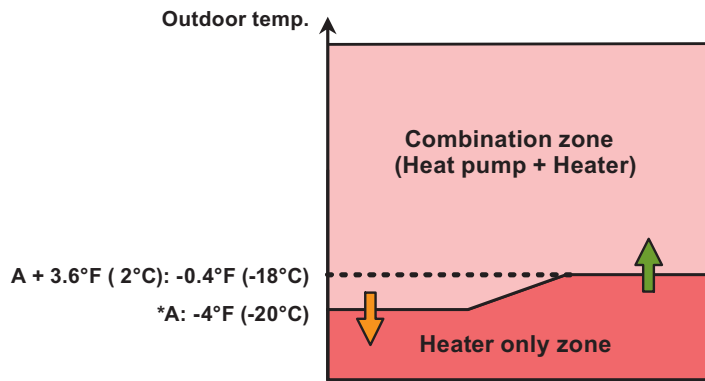

*: Adjustable by function setting 67

• Operation status

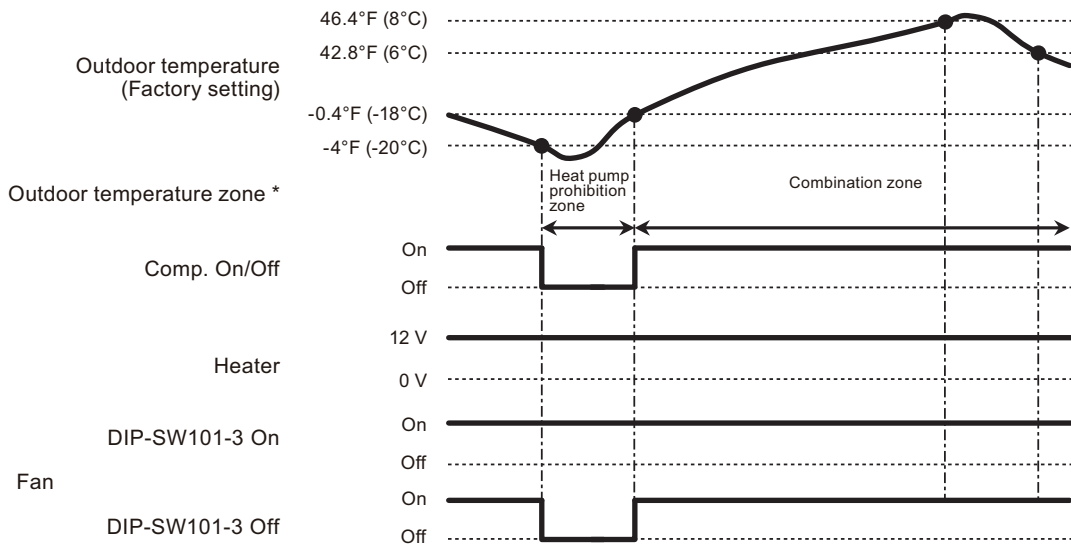

* The outdoor temperature zone transition from one to another will stay in that zone for minimum of 30 min.

NOTE: In following operations, compressor will be on in heat pump prohibition zone.

- Other than heating
- Test run

FIELD WORKING

FIELD WORKING

● Auxiliary heat pump control by outdoor temperature 2

• External heater output

Operation			Condition
Heater on			Heater is on as shown in following diagram of heating temperature.
Heater off	DIP-SW101-3 Indoor unit fan setting for external heater	On Enabled	<ul style="list-style-type: none"> • Heater is off as shown in following diagram of heating temperature. • Other than heating mode • Error occurred • Forced thermostat off • Fan stop protection
	DIP-SW101-3 Indoor unit fan setting for external heater	Off Disabled	<ul style="list-style-type: none"> • Heater is off as shown in following diagram of heating temperature. • Other than heating mode • Error occurred • Forced thermostat off

- Temperature of heater on (Thon): Set temperature (Ts) - 0.9 °F (- 0.5 °C)
- Temperature of heater off: Set temperature (Ts) + 0.9 °F (+ 0.5 °C)

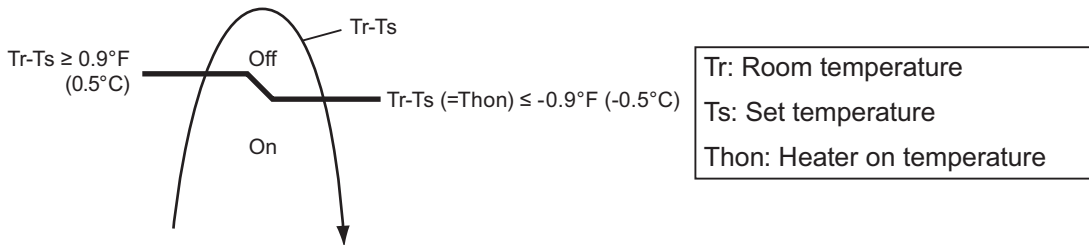

• Auxiliary heat pump On/Off

- Temperature of heater on (Thon): Adjustable by function number 62 (Operating temperature switching of heat pump).
- All control temperatures will shift by adjusting “Thon”.

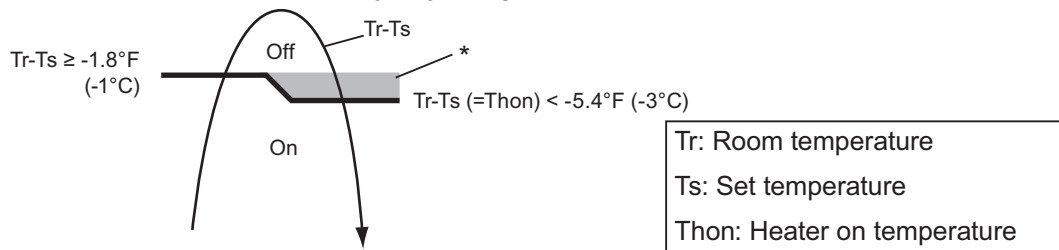

*: When room temperature stays in this zone for a specific time, auxiliary heater is turned on. For details, refer to function number 71.

• Outdoor temperature zone

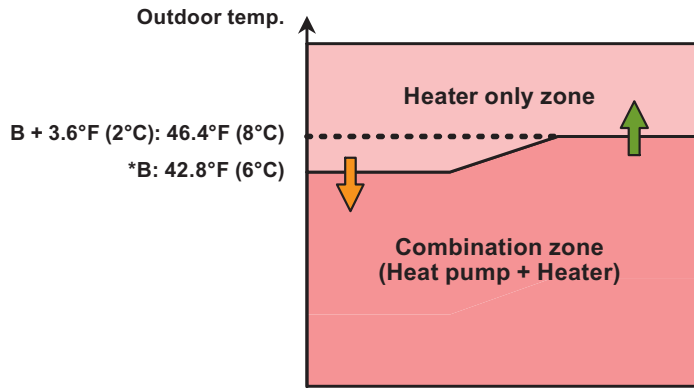

*: Adjustable by function setting 67

• Operation status

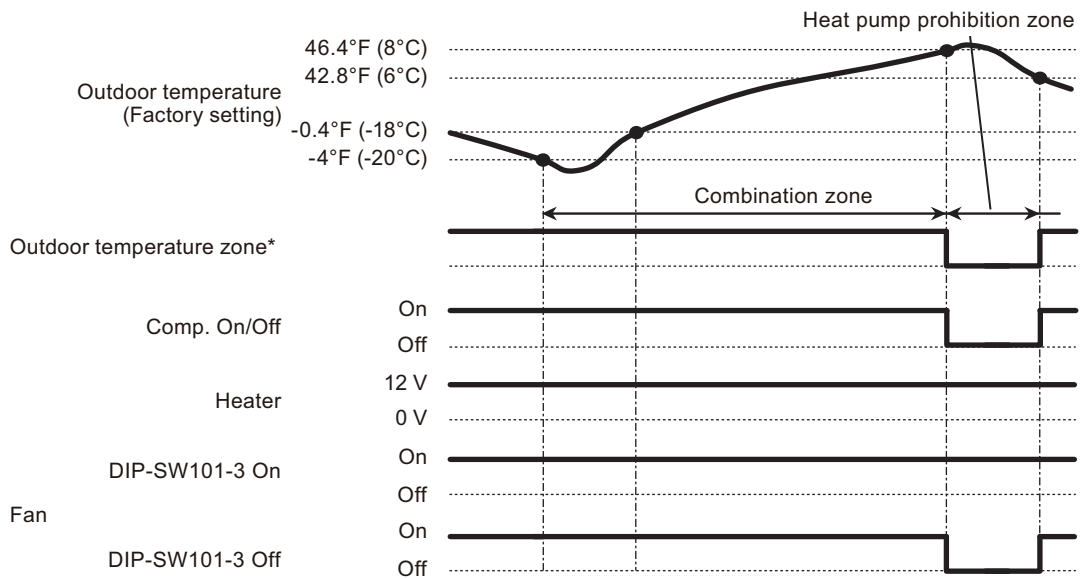

*: The outdoor temperature zone transition from one to another will stay in that zone for minimum of 30 min.

NOTE: In following operations, compressor will be on in heat pump prohibition zone.

- Other than heating
- Test run

FIELD WORKING

FIELD WORKING

● Auxiliary heat pump control by outdoor temperature 3

• External heater output

Operation			Condition
Heater on			Heater is on as shown in following diagram of heating temperature.
Heater off	DIP-SW101-3 Indoor unit fan setting for external heater	On Enabled	<ul style="list-style-type: none"> • Heater is off as shown in following diagram of heating temperature. • Other than heating mode • Error occurred • Forced thermostat off • Fan stop protection
	DIP-SW101-3 Indoor unit fan setting for external heater	Off Disabled	<ul style="list-style-type: none"> • Heater is off as shown in following diagram of heating temperature. • Other than heating mode • Error occurred • Forced thermostat off

- Temperature of heater on (Thon): Set temperature (Ts) - 0.9 °F (- 0.5 °C)
- Temperature of heater off: Set temperature (Ts) + 0.9 °F (+ 0.5 °C)

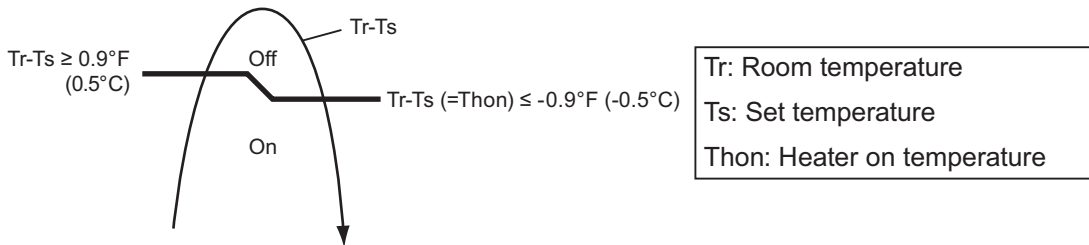

• Auxiliary heat pump On/Off

- Temperature of heater on (Thon): Adjustable by function number 62 (Operating temperature switching of heat pump).
- All control temperatures will shift by adjusting “Thon”.

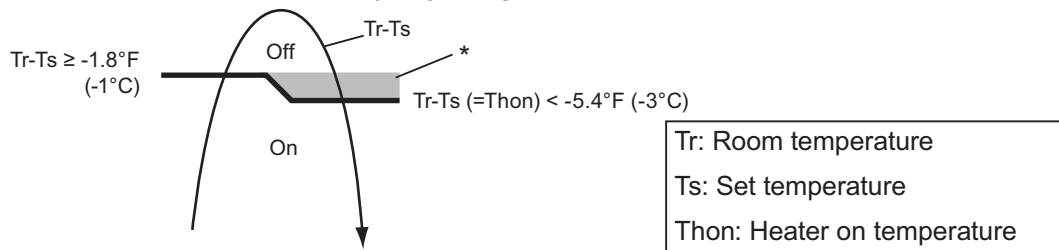

*: When room temperature stays in this zone for a specific time, auxiliary heater is turned on. For details, refer to function number 71.

• Outdoor temperature zone

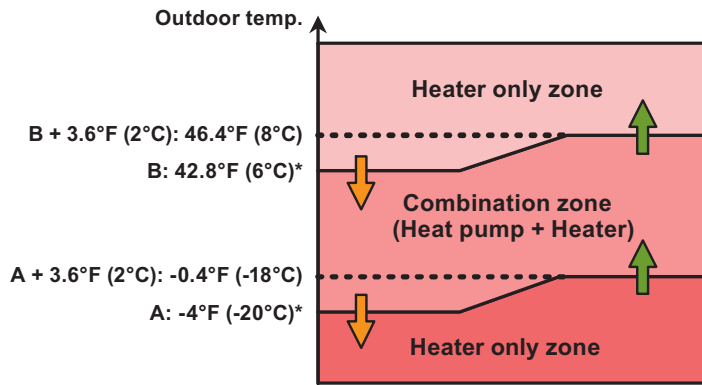

*: Adjustable by function setting 66 and 67

• Operation status

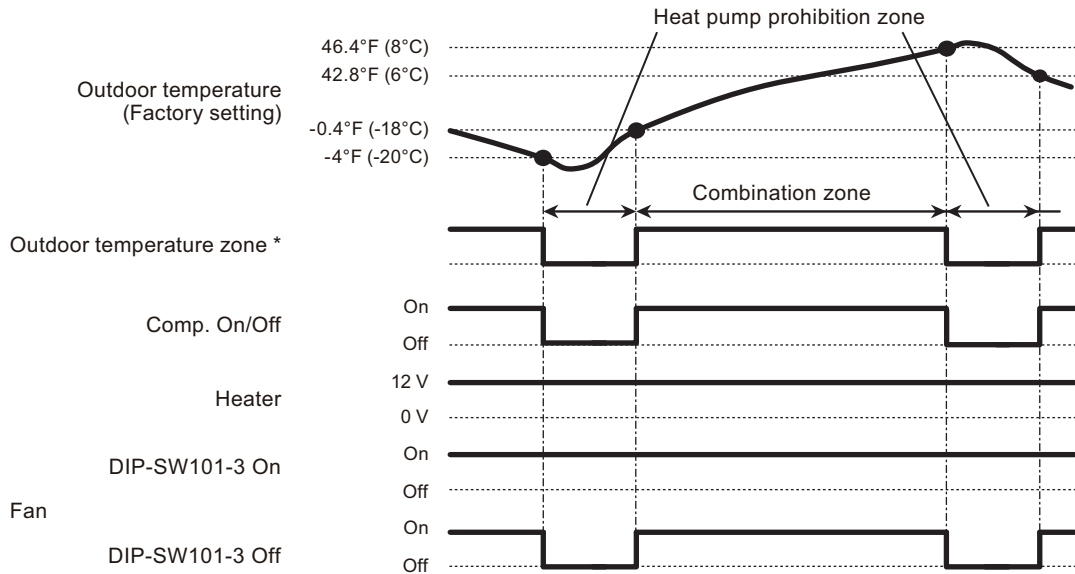

* The outdoor temperature zone transition from one to another will stay in that zone for minimum of 30 min.

NOTE: In following operations, compressor will be on in heat pump prohibition zone.

- Other than heating
- Test run

FIELD WORKING

FIELD WORKING

■ Heating thermostat on for humidifier

Situation	Indoor unit				
	Mode	Function setting	Rotary SW	External output	
		Heating thermostat on no. 60		Heating thermostat on	Indoor unit fan operation status
Example of individual connection	5	60-05	7	CN47	Not used
	6	60-06	8	Output3	
	7	60-07	9	Output2	
	8	60-08	A	Output1	

- Example of individual connection

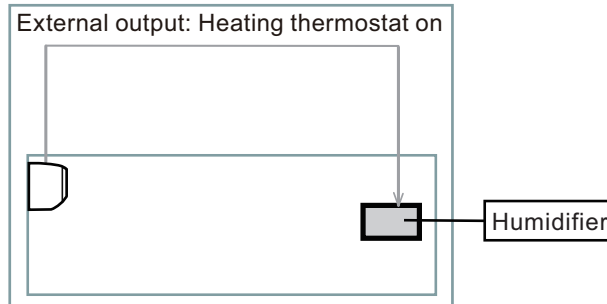

- Operation status

The heating thermostat output for CN47, Output1, Output2, and Output3 will be on when comp on or external heater on.

The heating thermostat output will be off when comp off and external heater off.

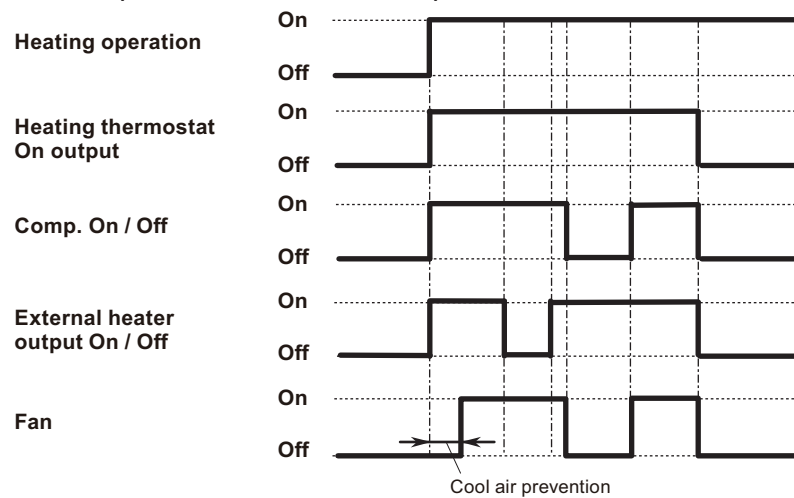

FIELD WORKING

FIELD WORKING