

2

1

PRODUCT #	VOLUME (US GAL)	STEEL THK. (gauge)	A	B	C	D	E	F	G	H	K	L
3011423	300	12	60	21	38¼	AS07122	AS07012	42½	0			3" NPT Min.
3020422	500	12	72	21	46	AS07153	AS07013	50½	0			4" NPT Min.
3020435	500	10	60	21	50¼	AS07122	AS07014	56	0			4" NPT Min.
3020445	500	7	60	21	50¼	AS07122	AS07014	56¼	0			4" NPT Min.
3039433	1000	10	118	50	50¼	AS07274	AS07014	56¾	25	50	AS07004	5" NPT Min.
3039443	1000	7	118	50	50¼	AS07274	AS07014	57	25	50	AS07004	5" NPT Min.

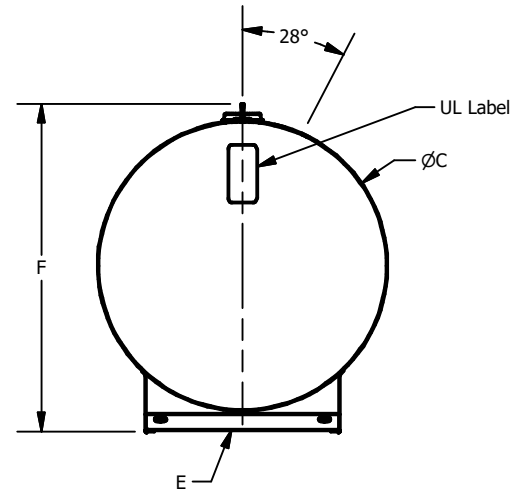
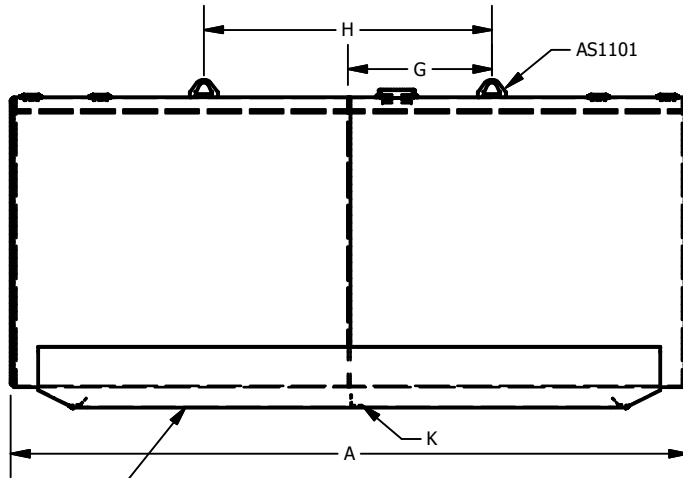
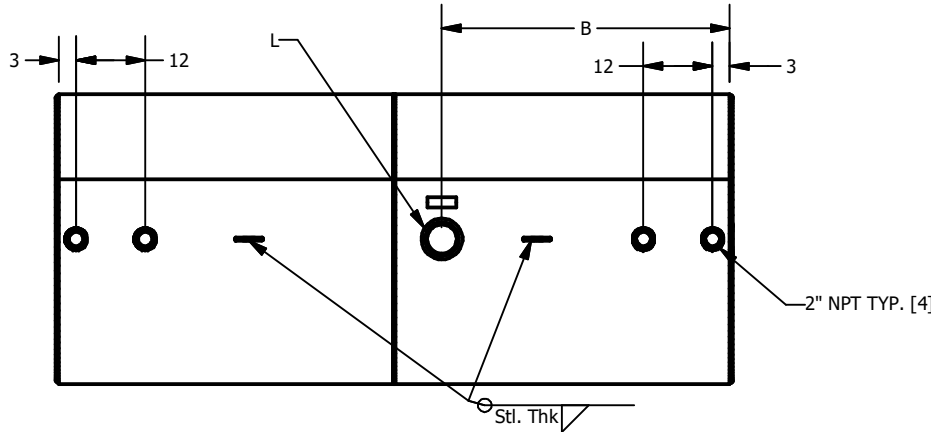

Ce dessin est la propriété exclusive de Industries Granby, SEC. Aucune partie de ce dessin ne peut être utilisée ou reproduite sans sa permission écrite.
 This drawing is the exclusive property of Granby Industries LP. No part of this drawing may be used or reproduced in any manner without its written permission.

TOLÉRANCES LINÉAIRES, LINEAR STD TOLERANCES 0 OR FRAC. (X/X) -> ±0.5" 0.00 -> ±0.125" 0.0 -> ±0.25" 0.000 -> ±0.0625"	Description de la révision / Revision description		
	Dessiné par / Drawn by M. Baril		2019-07-19
TOLÉRANCES ANGULAIRES, ANGULAR STD 0 -> ± 2 DEG. 0.0 -> ± 0.5 DEG. 0.00 -> ± 0.1 DEG.	Approuvé par / Approved by :		
Les soudures doivent respecter la spécification SI-0039. Tank welds must respect SI-0039 specifications.	Unités / Units INCHES	Échelle / Scale	Feuille / Sheet 1 / 1

Industries Granby S.E.C., Granby Industries L.P. © 2015 Industries Granby, SEC. Granby Industries LP			
Format / Size A	No de la pièce / Part no. SI0063	REV D.	
Description / Title GENERIC DRAWING FOR CYLINDRICAL HORIZONTAL SINGLE WALLED UL-142 TANKS ON SKIDS			

2

1

D-TANK_TMPLT-D