



MARS SERIES **217**



MARS Condensate Pump 24 Foot Lift

MARS new line of medium condensate pumps are designed to out-perform the competition while providing quiet operation and reliability.

The MARS pump design couples industry-leading performance with the installation flexibility and features you need to get the job done.

The quick release silicone check valve allows for quick and efficient servicing without the need to remove the condensate line. The integrated safety switch can be wire for equipment shut down or directly to a high level alarm.

Features:

- 24 ft. lift.
- 125 GPH.
- 0.5 gal. reservoir.
- Patent pending quick release check valve.
- Field serviceable “duck bill” check valve.
- Vibration absorbing rubber isolation feet.
- Drip-proof housing design and motor corrosion protection.
- Solid float.
- Integrated 250 volt safety switch and float switches.
- ABS and stainless steel construction.

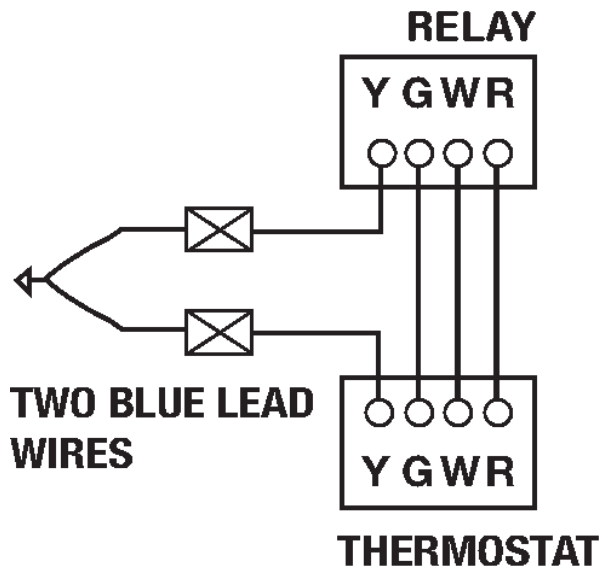

Item#	Lift	Electrical	Includes	Dimensions	Performance – gallons per hour @ height in feet					
					1 ft.	5 ft.	10 ft.	15 ft.	20 ft.	24 ft.
21780	24 ft.	115V 60 Hz 0.91 amp 71 watt	<ul style="list-style-type: none"> ▪ 3/8" quick release check valve ▪ Internal safety switch ▪ 6 ft. cord 	10.25" H 5.125" W 6.375" D	125 gph	98 gph	74 gph	70 gph	43 gph	7 gph