

NO.	PART	MATERIAL
1	HANDLE	ALUMINUM
2	STEM	FORGED BRASS
3	FIXING RING	PHOSPHOR BRONZE
4	O-RING	NITRILE RUBBER
5	SEAL	FIBER
6	SEATS	NITRILE RUBBER
7	BALL	CHROME PLATED BRASS
8	BODY	FORGED BRASS
9	WASHER	BRASS
10	HANDLE SCREW	STEEL
11	PLUG	FORGED BRASS

# Model T-3100

## Gas Ball Valve w/Side Tap

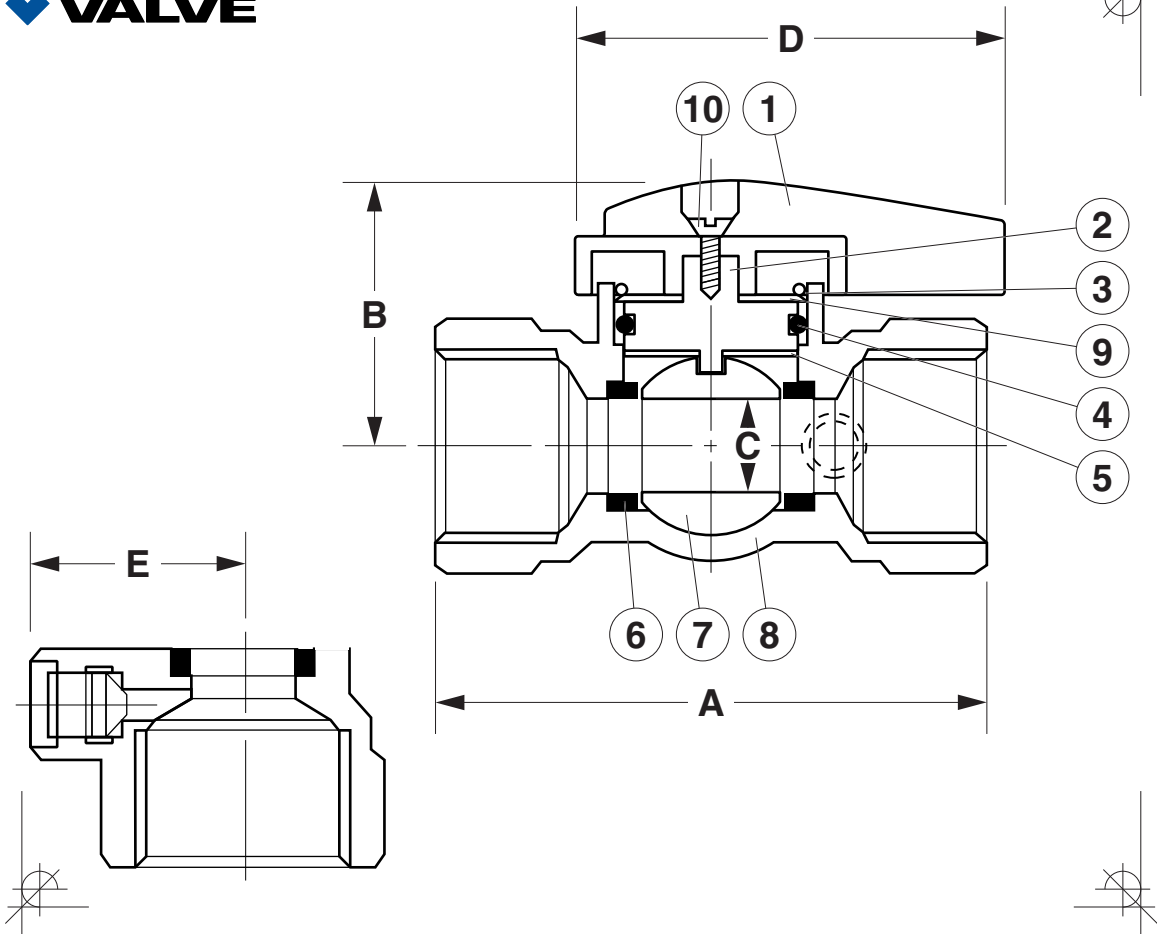

SIZE	1/2"	3/4"	1"	3100 FLxFL 3/8" x 3/8"	3100 FLxFL 1/2" x 1/2"
A	2.35	2.68	3.09	2.98	2.92
B	1.25	1.47	1.95	1.30	1.30
C	1.41	2.00	3.74	1.41	1.41
D	.78	1.06	1.22	.83	.85

- NOTES :
- 175 W.O.G. NON-SHOCK
- ANSI STANDARD Z21.15 FOR USE AS A GAS APPLIANCE CONNECTOR VALVE (1/2 LB. SYSTEM)
- AGA 3-88 FOR USE IN HOUSE PIPING SYSTEMS (2LB. SYSTEM)

